



Title	On dune formation
Author(s)	Aramata, M.
Citation	Memoirs of the Faculty of Engineering, Hokkaido Imperial University, 4, 293-299
Issue Date	1938
Doc URL	<a href="http://hdl.handle.net/2115/37705">http://hdl.handle.net/2115/37705</a>
Type	bulletin (article)
File Information	4_293-300.pdf



[Instructions for use](#)

# On Dune Formation.

By

M. ARAMATA.

In order to elucidate the processes of the formation of a dune, some of the influences of wind upon assemblages of sand have been investigated by making use of a wind tunnel, and paths of sand particles have been photographed.

## Apparatus.

In a wind tunnel the diameter of which is 50 cm as shown in Fig. 1, is placed a board having glass plates on both sides so as enable

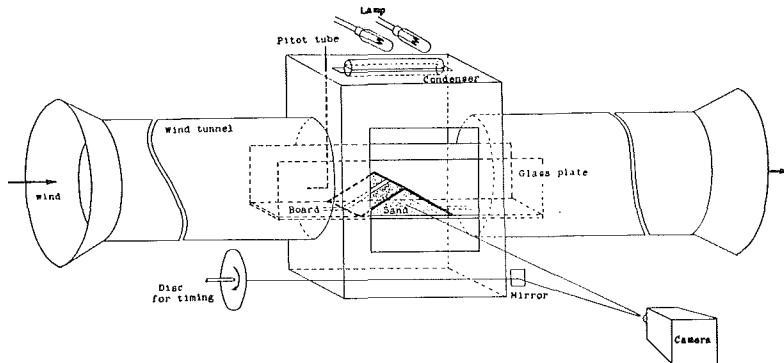

Fig. 1.

the observation of the cross section of a dune in the direction of wind. For photographing, a narrow parallel ray is introduced from above through a cylindrical lens. The photographs are taken laterally, and perpendicularly to the direction of wind, with a Cookes  $f. 2$  lens at full aperture. For determining the time of exposure, a disc with a small polished metal ball on its periphery driven by a motor is simultaneously taken in the photographs by means of a reflecting mirror. As a Solton shutter is used the images of the paths of the sand particles as well as of the metal ball are initially faint, become gradually more distinct and then become fainter. Therefore it is convenient that the motions of the particles are studied under the provision that the two images be compared with each other. The

velocity of wind at the front of the model of the dune is measured with Pitot tube, or a portable wind meter when the photographs are taken.

In the present experiments, standard quartz sand, mixed quartz sand and sand from the beach of Riyamunai which contains iron-sand in rather large percentage have been used, of which the specific gravities, sizes etc. are shown in the next table. As the last named has been generally used, that sand is meant by "sand", if the word is used without any note.

Table

	standard quartz sand	mixed quartz sand	sand from Riyamunai	
			sand except iron-sand	iron-sand
constituent				
percentage			87	13
size in mm	0.8-1.2	0.4-1.0	0.3-0.4	0.15-0.2
specific gravity	2.65	2.65	3.1	
porosity	0.41	0.45	0.41	

1) The case where the wind blows horizontally against a dry dune.

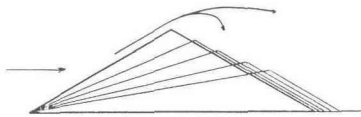

Fig. 2-a.

When the sand is piled up to form an isosceles, the dune is deformed gradually by the wind in the wind tunnel as shown in Fig. 2-a, the particles of sand being blown off as shown in Fig. 2-b.

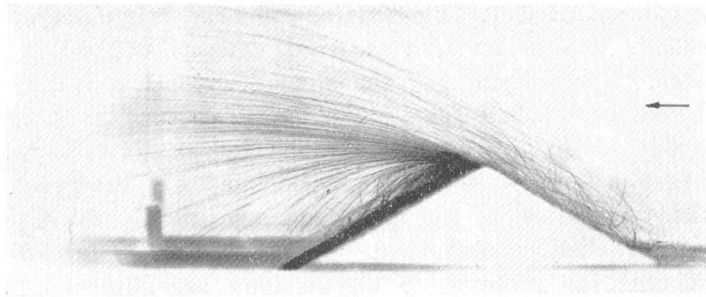

Fig. 2-b.

The particles lying on the front surface being driven, some fall on the back surface of the dune and the others fly away. Of the sand falling on the back surface of the dune, the percentage of iron-sand is the same as originally. Although the front surface looks black due to iron-sand during the blowing, this concentration of iron-sand is so limited that in the portion immediately under the surface it is not disturbed. If the wind is too weak to blow off the iron-sand, the front surface becomes stable. And if the wind is so strong that iron-sand is blown off too, the sand beneath it makes its appearance ready to be blown off. The iron-sand is blown off with more difficulty than the other constituents of the sand, so the surface looks black during the blow of wind.

When the angle of the slope is made the same as the angle of repose of this sand,  $30^\circ$  and the height 10cm, from such experiments with various velocities and also with the critical velocity of 6.2 m/sec at which present sand begins to move, a group of curves which show the angle of the front slope with respect to the velocity of sand is obtained, taking the time as a parameter, as shown in Fig. 3. Now as shown in Fig. 4, let  $l$ , and  $a$  be taken by which the decrease of the length of the back surface for a certain small interval of time are denoted, then

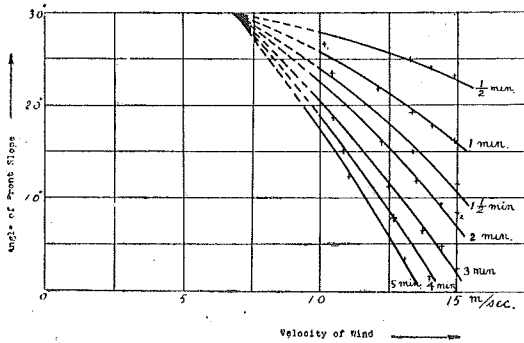

Fig. 3.

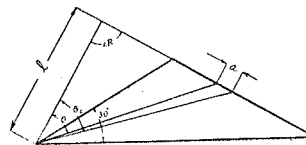

Fig. 4.

$$a = l(\tan \theta_2 - \tan \theta_1) = \frac{l \sin(\theta_2 - \theta_1)}{\cos \theta_1 \cdot \cos \theta_2}$$

From the assumption

$$\sin(\theta_2 - \theta_1) \doteq \theta_2 - \theta_1$$

and

$$\cos \theta_1 = \cos \theta_2 \div \cos \theta,$$

it follows 
$$\theta_2 - \theta_1 = \frac{a}{l} \cos^2 \theta.$$

Since  $a$  is constant at constant velocity, described before, the rate of decrease of the angle of front slope with respect to time is proportional to  $\cos^2 \theta$ .

2) The case where the wind blows horizontally against a dune whose front slope is wet.

Next is observed the deformation of the dune when the wind blows horizontally in the wind tunnel against a slope which is wetted to keep its form invariant, the other being left dry. With increase

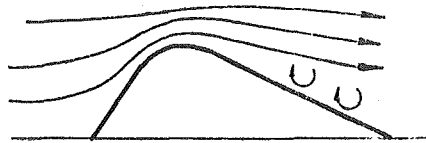

Fig. 5.

in the velocity of wind a reverse movement of the particles of sand on the back surface due to turbulent flow of air is seen, as shown in Fig. 5, although the sand is driven away on the whole. When the back slope is

too steep, the amount of reverse movement diminishes due to the action of gravity, although the turbulent flow may be very marked.

Initially the dune is constructed a height of 10 cm, the form of which is represent by curve 2 in Fig. 6.

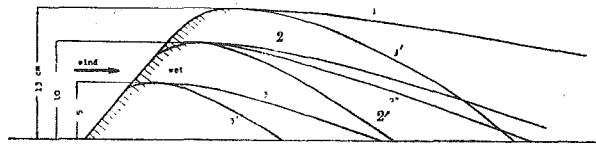

Fig. 6.

When the winds of velocities 12 and 9 m/sec blow against the wet slope, after about one hour stable forms are obtained respectively as shown by curves 2' and 2'' in Fig. 6. Making use of quartz sand instead of the sand from Riyamunai, the same stable forms are obtained under the similar conditions. Fig. 6 shows also the cases where the heights are 13 and 5 cm, the velocity being 13 m/sec.

Photographs are taken to elucidate the back motion of particles at the back surface. Fig. 7 shows a stage at which the backward motion starts rather rarely, while Fig. 8 is a state where the backward motion is more active.

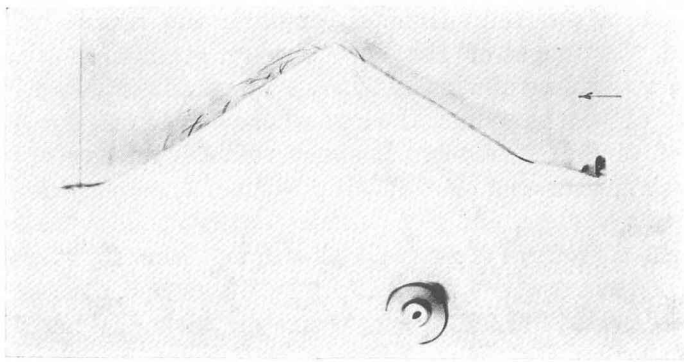

Fig. 7.

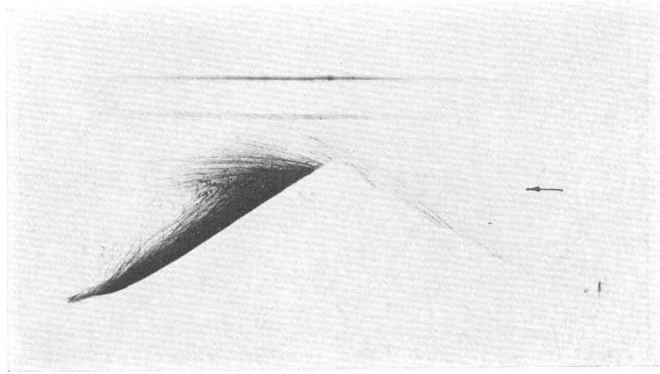

Fig. 8.

The front surface is made wet lest the particles from the front surface should not hide the paths of the backward motion. Making use of the same dimensions and form, a flake of cotton introduced on the back surface moves cyclically even under 1 m/sec of wind velocity in the wind tunnel. Although the paths of the particles shown in Fig. 8 do not show the air vortices perfectly, the vortices may be deduced nearly. The particles flying in reverse direction due to vortices which are caused to enter the zone of regular wind from that of the vortices are carried away by the regular wind. The growth of dune may be brought about, if the period of the wind blow is chosen to be such a one that the cessation of wind blow occurs when the sand blow flies or leaps upwards along the surface of the back slope. The optimum period of the repose of the wind would be too small to be attained in the present experiments in miniature. When use was made of standard quartz sand to construct a dune of the same magnitude and form at which remarkable backward motions of sand occur actively

in the case of the sand from Riyamunai, the reverse motions are rarer and the ranges of shot are shorter even when the greatest velocity ca. 15 m/sec of wind obtainable by means of this wind tunnel is applied. Fig. 9 illustrates the case where  $h = 13$  cm,  $\theta = 30^\circ$  and the velocity of wind is 11 m/sec. It shows that the velocity of the vortex at the back surface finds it difficult to move these particles of comparatively large mass, and the particles can not follow the air vortex. Though the current of air is slowed through the flight of sand, it seems that during such a small interval of time as 0.1 sec the particles can not receive a sufficient energy from the wind, as may be inferred from the fact that the velocity of particles photographed in Fig. 9 is 1.5–3 m/sec.

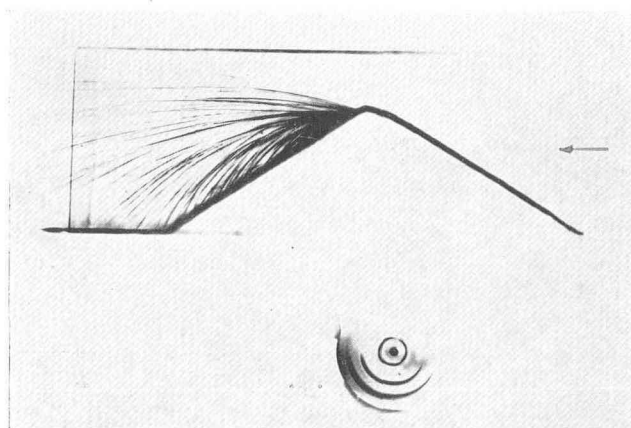

Fig. 9.

### Conclusion.

It is known that prevailing winds blowing from the sea perpendicularly to the beach or to a row of dunes play important roles in the development of the dunes. As initial conditions, that is to say, nucleus, some obstacles or meteorological discontinuity may be taken for granted from an example in which properly arranged pegs for defence works against sand make an artificial dune several meters high within a year. Whatever the initial conditions may be, the present experiments seem to throw some light qualitatively upon the growth of dunes, although the experiments are too imperfect for a quantitative interpretation. The reverse motion of sand and the breadth of wind may make the dune large as described in case 1, and also in the case

of a front surface wet by splashes of waves or other agency, the reverse motion of sand on the back surface may prevent the dune from being flattened.

• In conclusion, the writer wishes to express his best thanks to Prof. Y. Ikeda for valuable suggestion and kind guidance.

