



Title	Design of an Integrating Thermometer
Author(s)	Magono, Choji
Citation	北海道大學理學部紀要, 4(1), 1-20
Issue Date	1951-02
Doc URL	http://hdl.handle.net/2115/34191
Type	bulletin (article)
File Information	4_P1-20.pdf



[Instructions for use](#)

Design of an Integrating Thermometer

By

Choji MAGONO

(Received January 20, 1950)

By the use of the variation of viscosity of liquids with temperature, the author produced a series of integrating thermometers which can be used easily in the laboratory and even in the field.

1. Introduction.

In some fields of investigation, the integrated value of temperature is of more significance than the instantaneous value of temperature; for example, in the case of studying the relation between the growth of a crop and the temperature. In those cases it is desirable to have an instrument which can show the integrated value of temperature directly.

By the use of the variation of viscosity of liquids with temperature, the author produced a series of integrating thermometers which can be used easily in the laboratory and even in the field.

2. Principle of an Integrating Thermometer.

It is well known that there is the following relation between the volume v of a liquid passed through a capillary tube in unit time and the viscosity coefficient η of the liquid

$$v = \frac{\pi r^4 p}{8 l \eta}, \quad (1)$$

where r is the radius of the capillary, l its length, and p the pressure difference acting on the fluid at the two ends of the capillary tube. In this paper, the author calls v the velocity of liquid flow.

η is a function of temperature in the following form¹⁾

$$\eta_\theta = \frac{\eta_0}{1 + a\theta + b\theta^2}, \quad (2)$$

where η_0 is the viscosity coefficient of liquid at $\theta^\circ\text{C}$, and α , b are constants characteristic to the liquid. For a small range of temperature intervals, the quadratic term in formula (2) can be neglected,²⁾ so that it becomes

$$\eta_\theta = \frac{\eta_0}{1 + a\theta} \quad (3)$$

From formulae (1) and (3) we have

$$v = \frac{\pi r^4 p}{8l\eta_0} (1 + a\theta) \quad (4)$$

If the apparatus is designed so that p is kept constant during the flow of the liquid, the term outside the parenthesis in formula (4) is a constant characteristic to the apparatus. In that case the relation between the velocity of the liquid flow and the temperature is expressed in a simple linear form as

$$v = k(1 + a\theta) \quad (5)$$

Integrating formula (5) for a time interval T , we get

$$\theta = \frac{V}{ak} - \frac{T}{a} \quad (6)$$

where

$$\left. \begin{aligned} V &= \int_0^T v \, dt \\ T &= \int_0^T dt \\ \theta &= \int_0^T \theta \, dt \end{aligned} \right\} \quad (7)$$

θ is the integrated value of temperature during the time interval T , and V is the total volume of the liquid which flowed through the capillary. If the constants a , k are known, we can calculate the integrated value of temperature θ by measuring the total volume V only.

If the relation between the velocity of flow and the temperature is not able to be expressed in a linear form as (5), we can not calculate the integrated value of temperature from the total volume of the liquid flowed through the capillary. We must, therefore, use this method only in the range of the temperature in which the relation between the velocity of flow and the temperature is considered to be linear.

When we let the liquid drop down from the tip of the capillary, the surface tension has some effects upon the interval of dropping as well as upon the size of the drop, but the effects of surface tension upon the velocity of flow are not remarkable. Besides, the temperature coefficient of the surface tension is negligible as compared with that of the viscosity.

3. Trial Production of various Forms of Integrating Thermometers.

By use of the apparatus as shown in Fig. 1, the author investigated the relation between the temperature and the velocity of water flow through a capillary tube. The apparatus is all made of glass. The water reservoir and the capillary tube are connected with a short rubber tubing. In order to prevent the choking of the capillary with dust, a portion of the glass tube bent so that any dust in the water is deposited at that point.

The radius of the capillary is about 0.1 mm, the length 13 cm, the water head being 38 cm.

The velocity of flow was measured by the volume of water dropped in unit time into the measuring cylinder M. The time interval between successive drops was of the order of several seconds.

It was verified by the experiment with this apparatus that the relation between the velocity of flow v and the temperature θ was linear, as shown in Fig. 2. The following empirical formula was obtained from Fig. 2.

$$v = 0.0580 (1 + 0.0362\theta) \text{ cc/min.} \quad (8)$$

From formula (8), the integrated value of temperature θ is calculated as follows.

$$\theta = 79.5 V - 27.6 T', \quad (9)$$

where V is the total volume of water received in M expressed in cc, and T' the time

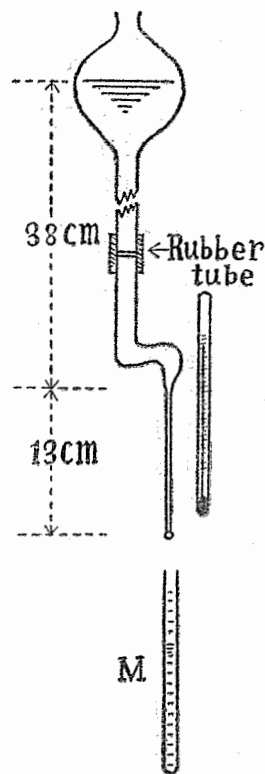

Fig. 1.

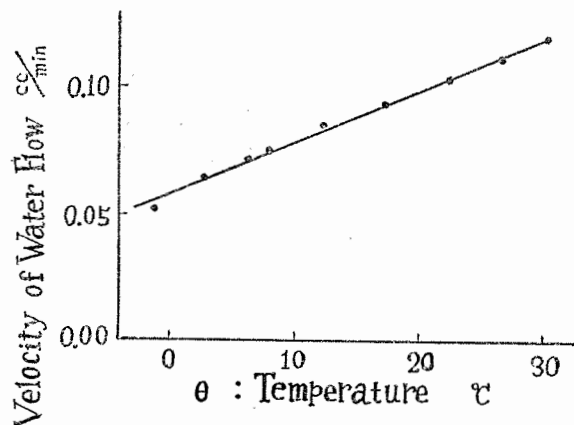

Fig. 2. The relation between the velocity of water flow and the temperature.

interval expressed in hour.

In order to keep the water head constant a small development was made, as shown in Fig. 3. It is called Apparatus No. 1. When the water level at L goes down according to the water flow through the capillary, a little bubble goes into the bottle B through the curved glass tube T, and the water of the same volume as the bubble is supplied from the bottle B to L, thus the level at L being kept constant.

With Apparatus No. 1, the author measured the integrated value of air temperature in the laboratory room from 16th to 17th, Jan., 1946. V , T were 103 cc and 21.5 hours respectively. Calculating by formula (9), θ was obtained as

$$\theta = 227 \text{ degree} \cdot \text{hour.}$$

While the integrated value of temperature calculated from the data obtained by a mercury thermometer was 229 degree·hour. The result of temperature measurement is shown in Fig. 4. The difference is only 1%. The relation between v and θ is accurately linear, as shown in Fig. 2, so we can expect the enough accuracy of this instrument, unless any dust does not choke the capillary.

The possibility of the precise measurement of the integrated

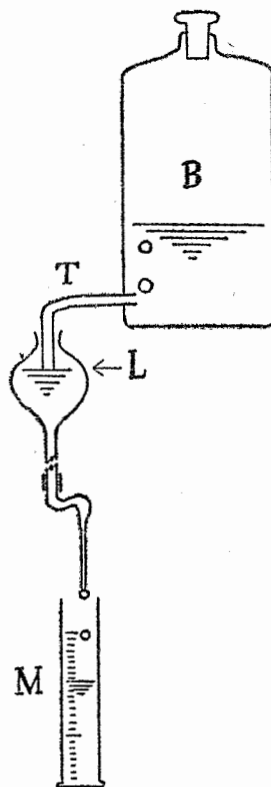

Fig. 3. Apparatus No. 1.

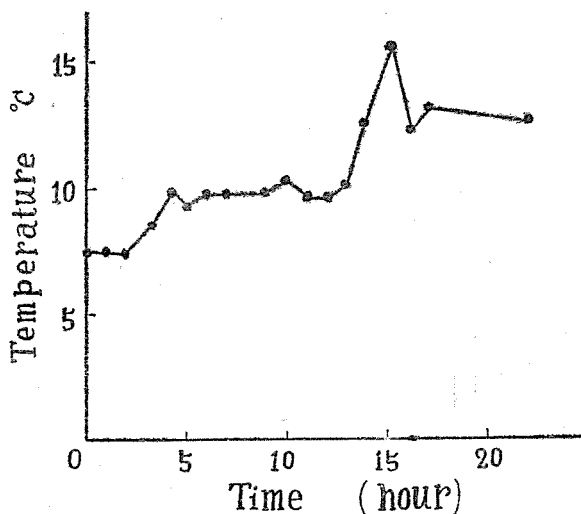

Fig. 4. The air temperature measured by a mercury thermometer.

value of temperature was established by the provisory experiment above mentioned, so the author designed an improved type of apparatus as shown in Fig. 5, which was called Apparatus No. 2. In this case the water head is kept constant and the water is preservative. When the water level L begins to fall down, a bubble goes into the vessel A through the tube T, and the air pressure in A increases. Thus the level L is kept constant.

The air that is supplied through T is sterilized by bubbling through sulphuric acid in P.

In case when water is supplied to the vessel A after one run of the experiment is over, the apparatus is turned over, the cock is changed, and water is poured into A from the funnel F.

This procedure is tedious and inconvenient, because the rate of water supply depends on that of the air flow through the capillary C. For example, two hours are necessary for supplying water to an integrating thermometer for one week run, because the viscosity of air is about one-hundredth of that of water. Before starting the measurement, the water head should be enough high, and the experiment is started at the moment when the water level in T falls to L. This point is very inconvenient for the practical purpose.

As the next step the author designed another type which is

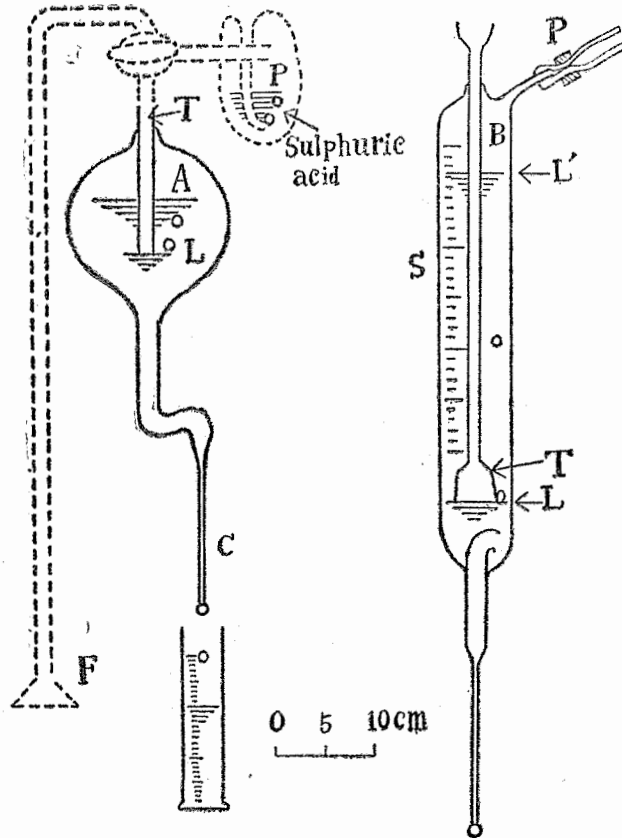

Fig. 5. Apparatus No. 2. Fig. 6. Apparatus No. 3.

called Apparatus No. 3. The diagram and the photograph are shown in Fig. 6 and Photo. 1. In this apparatus, the water level at L is kept constant as in the preceding case. The volume of water that flowed through the capillary is measured by the change of the level L', which is read by the scale S marked on the vessel B. Water is supplied through the central tube, the pinch-cock P being open meanwhile. It is not so tedious as in the case of Apparatus No. 2. The water left in the central tube above L can be easily removed by sucking out the air in B through P, so that the water head is brought to the level L at any time when the experiment is started.

The foregoing apparatuses, however, have still the following defects. The one is that it is difficult to supply enough quantity of such water as contains no dust at all for the use of a long time, the

other is that the level of water varies sensibly when the air temperature in the reservoir vessel rises suddenly. For example, in Apparatus No. 3 when the air in the vessel B expands due to the rise of temperature, it pushes the water level L up into T.

In order to avoid the sudden change of the level at L, the opening of the tube T was widened as shown in Fig. 6, but it was still insufficient.

In order to get rid of these defects, the author adopted a new principle of evacuated system. The first design basing on this new principle is shown in Fig. 7 and Photo. 2. This type is called Apparatus No. 4. In this case water is not supplied from outside, but enclosed in the apparatus. The water in the vessel A flows through the capillary of a spiral form and drops down from the tip C into the cylinder M, on the wall of which a scale is marked. The scale is not uniform, but varies the width according to the change of water level in A. When all the water in A flows into M, the apparatus is turned over and the water in M is sent back to A. For this purpose the apparatus is evacuated. The water is distilled previously and enclosed in the vessel, so it can be free from any contamination for a long time.

So long as, however, we use water as a working liquid, we can not get rid of a difficulty that interrupts the water flow through capillary. The reasons are as follows:

- 1) Capillary must be extremely fine, as the viscosity of water is

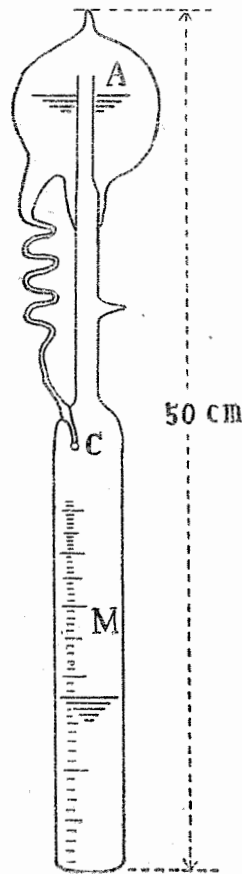

Fig. 7.
Apparatus No. 4.

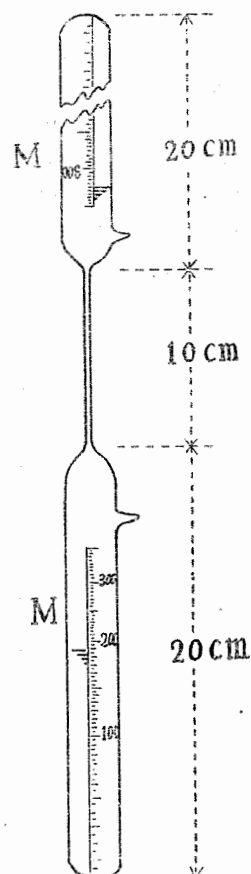

Fig. 8.
Apparatus No. 5.

too small for our purpose.

- 2) Glass is corroded by water. The capillary of Apparatus No. 4 was choked, after using three monthes, by some fine particle like a piece of glass.
- 3) The fine bubble of gas or vapor goes into capillary, even if the apparatus has been well evacuated.
- 4) In the type as Apparatus No. 4, if a temperature difference exists between A and M, the level of water in M varies due to the pressure difference of the water vapor in A and M.

The author, therefore, proceeded to use the oil of a diffusion pump in place of water, and produced Apparatus No. 5, as shown in Fig. 8 and Photo. 3. This apparatus consists of two symmetrical glass cylinders and a connecting capillary tube. Each of these glass cylinders serves as a reservoir as well as a receiver, and the apparatus is used repeatedly by being turned over like a sand-glass.

By the use of this apparatus, the author investigated the relation between the velocity of oil flow and the surrounding temperature. The result is shown by a dotted line in Fig. 9. The ordinate shows the velocity of oil flow in an arbitrary unit. From Fig. 9 we know that the temperature variation of the velocity of oil flow is larger

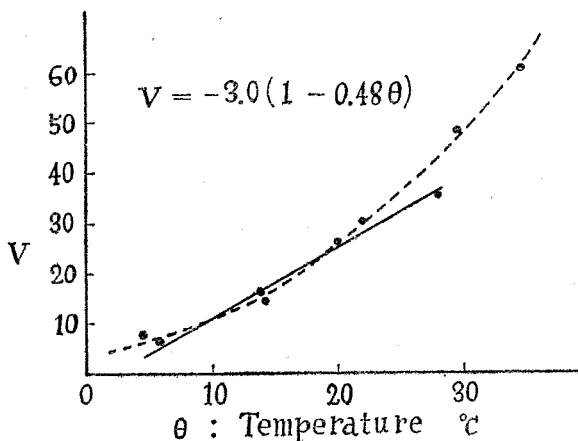

Fig. 9. The relation between the velocity of oil flow and the temperature in the case of Apparatus No. 5.

than the case of water, but the linearity of the relation between v and θ is not satisfactory. Then the author assumed that the relation between v and θ is linear within a certain range of temperature.

In the range between 5°C and 30°C, it is assumed that the relation is expressed by a full line in Fig. 9. Under this assumption the following formula is obtained.

$$\theta = 0.70S + 2.1T, \quad (10)$$

where S is the reading of the scale showing the amount of oil accumulated in the cylinder M during T days.

Using Apparatus No. 5, the author measured the integrated value of air temperature in the laboratory room for ten days starting from 12th Jan., 1947, and obtained

$$S = 168 \quad T = 10.$$

Calculating from formula (10), θ came out to be 139 degree·day. While the integrated value of temperature calculated from the record of a self-recording thermometer, Fig. 10, was 137 degree·day. The

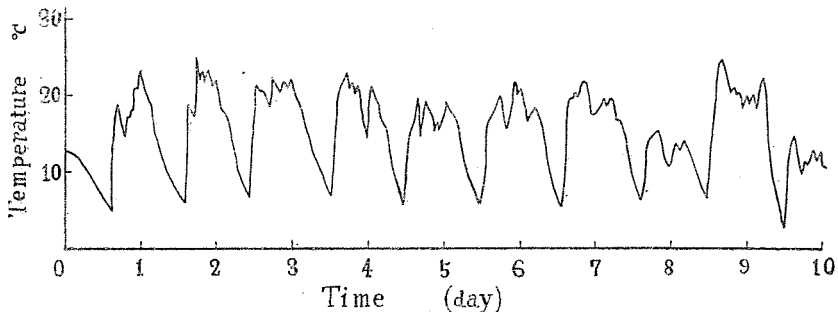

Fig. 10. The record of air temperature obtained by a self-recording thermometer.

difference is 2 % in this case.

Apparatus No. 5 is of a simplest form and operated for about one month without much difficulty, but it has still the following defects.

- 1) The reproducibility is not satisfactory. This should be due to the following facts. The one is that the oil flows down by wetting the inner wall of the glass cylinder, the other that the trace of the air left in the vessel together with the vapor of the oil, if any, may disturb the oil flow through the capillary.
- 2) When we use this apparatus repeatedly by turning it again and again, we must use the inaccurate part of the scale. In addition to that, at the beginning of measurement, the reading of the scale S is not always zero.

After the long course of the trial production of various forms from No. 1 to No. 5, the author has arrived at the final form of the apparatus, which he called Apparatus No. 6. This final type is shown in Fig. 11 and Photo. 4. The oil in the vessel A comes to the capillary C through the interspace I between two cylinders, and drops down from the tip of the capillary C into the cylinder M, on the wall of which a scale is marked. In order to decrease the effect of the change in oil head, the diameter of the vessel A is made enough large. The distance between the oil head and the capillary tube is taken enough long so that the small difference in the oil head does not affect the pressure considerably. At the beginning of the measurement, all the oil deposited in the cylinder M is sent back to the vessel A by turning over the apparatus. Small cylinder D serves to prevent the oil left on the inner wall of the cylinder T to flow down to the cylinder M. The capillary is enclosed inside of the apparatus, so it is protected safely from the damage.

In the following sections the author will explain the structure and action of Apparatus No. 6 in detail.

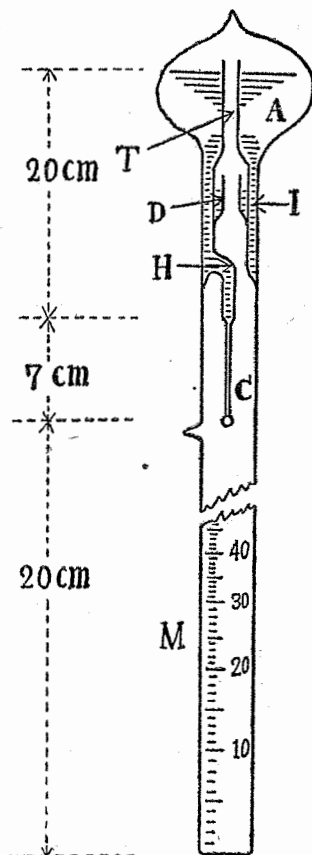

Fig. 11.
Apparatus No. 6.

4. Notes on the final Form of the Integrating Thermometer.

1) *Selection of Capillary.*

As the velocity of oil flow through a capillary tube is proportional to the fourth power of the radius of the capillary as seen in formula (1), we can estimate the velocity rather roughly, even if we measure the radius accurately. The author, therefore, tested many capillary tubes whose diameter was about 0.5 mm by letting water flow through them. When a suitable capillary is found, it is

cut in a desired length and fitted to the apparatus. In the operation of the glass blowing to connect the capillary C to H in Fig. 11, it is necessary to be careful not to let any fine piece of glass go into the capillary tube.

2) *Enclosure of Oil.*

About 90 cc of diffusion pump oil is poured into the apparatus immediately after breaking the seal of the bottle of oil, and the apparatus is connected to an air pump and the whole system is evacuated to the vacuum of about 10⁻⁴ mm Hg. Under this vacuum any bubble of the oil is scarcely observed. Then the apparatus is sealed.

3) *Calibration of the Scale.*

The apparatus is kept in a thermostat which temperature is at 20°C, and the level of oil deposited in the cylinder is marked every six hours. The intervals between the marks are divided into five equal parts, so that the one interval corresponds to one degree-day. The apparatus of the size as shown in Fig. 11 has about 90 degree-day in full scale at the temperature near 20°C. The marks are later etched with hydrogen fluoride.

4) *Calculating Formula for the Integrating Thermometer.*

The relation between the temperature and the velocity of oil flow is shown in Fig. 12. The ordinate is the quantity of the oil

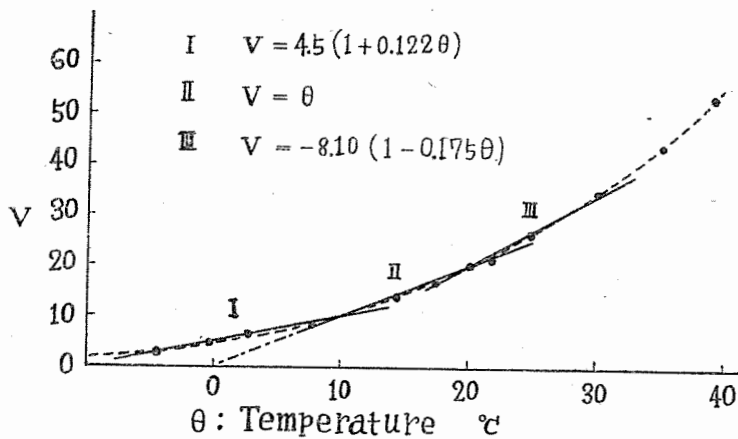

Fig. 12. The relation between the velocity of oil flow and the temperature in the case of Apparatus No. 6.

which dropped during one day; namely, the integrated value of temperature for one day measured with above-mentioned scale.

The velocity variation with the temperature is somewhat smaller in the case of this oil than the case shown in Fig. 9. The linearity of the relation is better than the former case.

In order to increase the accuracy, the author divided this characteristic curve between v and θ into three ranges as shown in Fig. 12, and assumed the relation as linear in each range. Then three calculating formulae I, II, III are obtained for each range of temperature respectively, as shown in TABLE I.

TABLE I *Calculating Formulae for the Integrating Thermometer*

Range of Temperature (°C)	S/T	Calculating Formula	
- 10 ~ + 12	0 ~ 11.0	I	$\theta = 1.80 S - 9.0 T$
+ 10 ~ + 23	11.1 ~ 20.0	II	$\theta = S$
+ 18 ~ + 32	20.0 ~ 38.0	III	$\theta = 0.710 S + 5.8 T$

S is the reading of the scale of the oil deposited during T days.

The straight line for the range II which covers between 10°C and 23°C, passes fortunately the origin; that is, 0°C, as shown in Fig. 12. So the integrating temperature θ in this range is directly read by S .

The solidifying point of this oil is about -10°C, so we can not use this apparatus below -10°C.

5. Method of Measurement.

1) At the beginning of measurement, send back the oil in the receiver cylinder M to the reservoir vessel A by turning over the apparatus, and let it stand vertically at the required place.

2) At the end of measurement, read the scale S and calculate the number of days T .

3) Select the calculating formula according to the rough value of temperature during that time, or S/T .

If the apparatus is kept for ten minutes in the overturned position, the oil returns almost completely to the reservoir vessel. At the beginning of measurement, the reading of the scale should be zero.

The thermal expansion coefficient of this oil is about 1.1×10^{-3}

gas, but the correction of the reading due to thermal expansion is unnecessary, unless the scale is read at such temperature as extremely differs from the mean value of the temperature during the time of observation.

The time lag of this apparatus is slightly larger than ordinary mercury thermometer, and the influence of the lag on the integrated value of temperature is negligible in most cases.

Occasionally a minute bubble of oil appears between the capillary C and cylinder H, but its influence on the velocity of oil flow is negligible, because the bubble disappears sooner or later.

6. Results of the Observation.

The excellent reproducibility of this apparatus will be understood from the results of the experiments shown in Fig. 12. Those points in the Figure were obtained by a series of the experiments, in each of which the oil was sent back to the vessel A and the measurement was started from zero point of the scale. The fact that those points lie on a smooth curve, shows the satisfactory reproducibility of the apparatus.

The followings are the examples of the measurements made with Apparatus No. 6 at various places in Sapporo. Figs. 13 and 14 show the records of the air temperature obtained by a self-recording

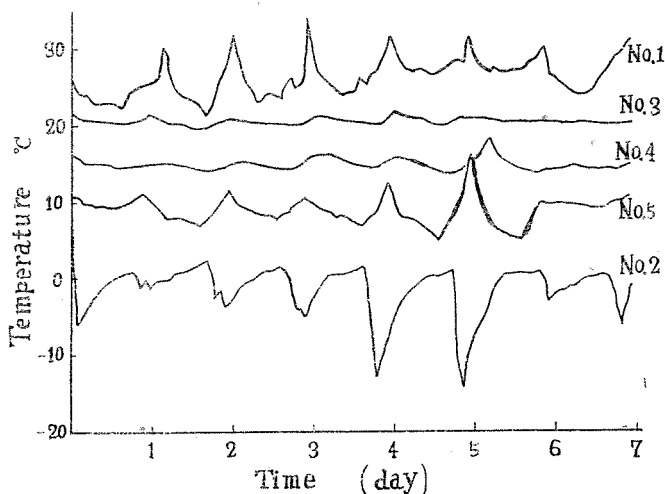

Fig. 13. The records of the air temperature obtained by a self-recording thermometer in 1948.

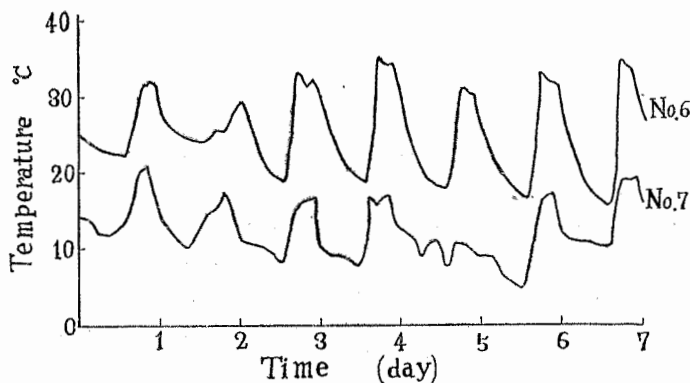

Fig. 14. The records of the air temperature obtained by a selfrecording themometer in 1949.

thermometer, which was corrected by the data of a mercury thermometer.

TABLE II *Integrated Value of Air Temperature*

No.	Date	S	T	S/T	Calculating Formula	θ deg · day	θ' deg · day	Difference per day $\frac{\theta' - \theta}{T}$ deg
1	Jul. 30—Aug. 6 1948	196.9	7	28.1	III	180.6	181.4	0.1
2	Aug. 16—Aug. 23 1948	29.4	7	4.2	I	-10.0*	- 6.0	0.6
3	Sep. 6—Sep. 13 1948	144.5	7	20.6	II	144.5	144.3	- 0.0
4	Sep. 27—Oct. 4 1948	104.2	7	14.9	II	104.2	104.4	0.0
5	Oct. 27—Nov. 3 1948	70.3	7	10.0	I	63.3	61.6	- 0.3
6	Aug. 31—Sep. 6 1949	181.9	7	26.0	III	171.2	173.7	0.4
7	Nov. 19—Nov. 26 1949	81.4	7	11.6	II	81.4	82.6	0.1

*: Measured in a Cold Chamber Laboratory.

θ : Integrating temperature measured with Apparatus No. 6.

θ' : " " calculated from Fig. 13 or Fig. 14.

The difference between the data obtained with Apparatus No. 6 and those with a self-recording thermometer is always less than half a degree per day, except in the case of measurement No. 2 which was made in a Cold Chamber Laboratory.

The large difference in measurement No. 2 is probably due to the following reasons.

- 1) Calculating formula I is not suitable.
- 2) Integrating thermometer of viscosity type is not sensitive at low temperatures.
- 3) During the measurement, the room temperature fell down occasionally below the solidifying point -10°C .
- 4) The record of the self-recording thermometer was also inaccurate.

It may be remarkable that even under this worst condition the difference between two integrated values of temperature is only six-tenth degree per day.

We can consider, therefore, that the accuracy of our integrating thermometer is in the same order as that of a self-recording thermometer corrected with a mercury thermometer.

7. Considerations on the working Liquids.

Following properties are necessary for the liquid to be used in an integrating thermometer of viscosity type.

- 1) Not contain any fine dust or particle.
- 2) Must be stable thermally and chemically.
- 3) No condensation or sublimation within the range of the temperature to be measured.

Following properties are also desirable.

- 4) A relatively large value of viscosity coefficient, in order to avoid to adopt an extremely narrow capillary.
- 5) A large viscosity variation with temperature in order to get a high sensibility. As a rule, those liquids which are of large viscosity coefficients have also large value of thermal expansion coefficients. But the error due to thermal expansion is usually negligible, as already stated.
- 6) A low vapor pressure is desirable so as to get rid of the growth of a fine bubble in the capillary. Such a liquid has generally a large viscosity too.
- 7) The most important property is to have a linear relation between the temperature and the velocity of liquid flow through capillary.

This last mentioned property is necessary to obtain an accurate calculating formula, but it is generally contradictory to the properties

mentioned in 4) and 5). The detailed explanation on this problem will be done in the next section.

Considering these properties, it seems that the oil used in a diffusion pump is most suitable as a working liquid in the integrating thermometer, except the property mentioned in 7).

8. Sensibility and Accuracy.

In the integrating thermometers above-mentioned, the sensibility does not always agree with the accuracy, for the larger the temperature variation of the flow velocity, the worse the linearity of the characteristic curve of the oil. In other words, the higher the sensibility is, the more the calculating formula becomes inaccurate. Some examples will be shown on this point.

From formula (1), it is obvious that the velocity v of liquid flow is proportional to the fluidity ϕ which is the reciprocal of the viscosity coefficient η of the liquid. Taking ϕ_0 as the fluidity at $\theta^\circ\text{C}$, ϕ_{30}/ϕ_0 will be taken as a measure of the fluidity variation with temperature. This is equal to v_{30}/v_0 . The linearity of the liquid will be measured by ϕ_{15}/ϕ_m , where ϕ_m is the mean value of ϕ_0 and ϕ_{30} . If ϕ_{15}/ϕ_m is unity, the linearity is perfect. The relations between these quantities are shown in Fig. 15.

The fluidity variation with temperature is illustrated in Fig. 16

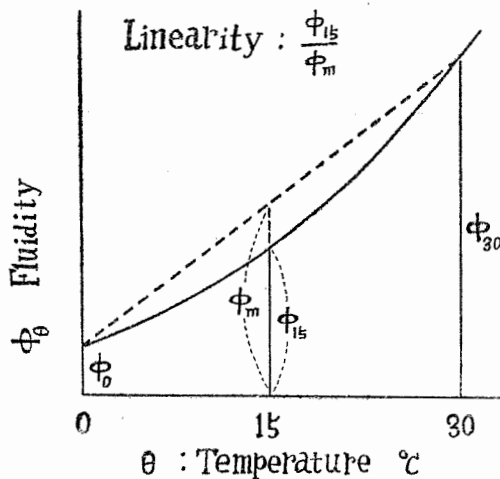

Fig. 15. The relation between the fluidity and linearity.

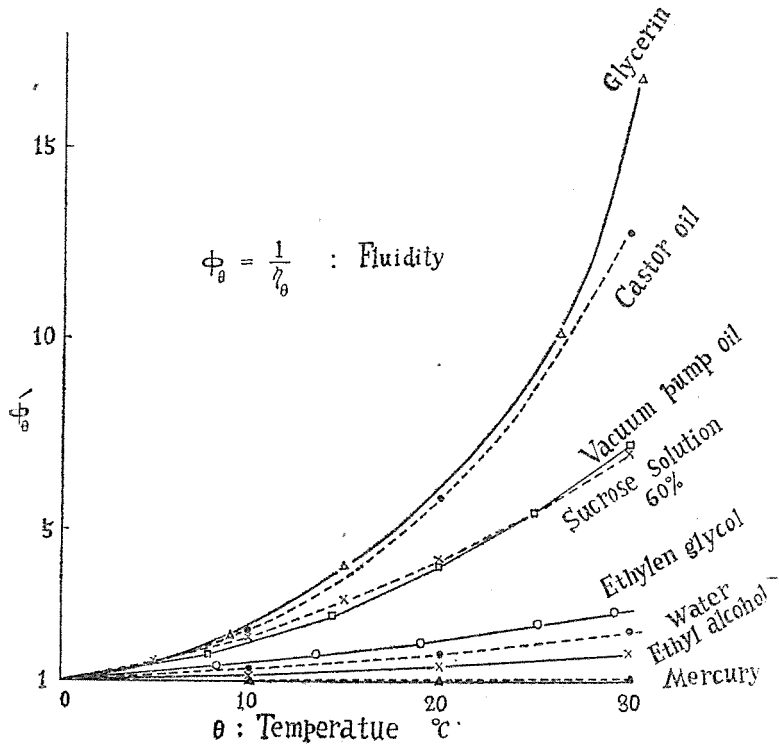

Fig. 16. The fluidity variation with temperature for several liquids.

for several liquids, and their linearities ϕ_{15}/ϕ_m are calculated for all those liquids and are shown in TABLE III.

TABLE III

Liquid	Linearity ϕ_{15}/ϕ_m	ϕ_{30}/ϕ_0	Viscosity at °C
Mercury	1.000	1.160	0.0168
Turpentine oil	0.999	1.768	0.0225
Chloroform	0.991	1.370	0.0070
Water	0.936	2.238	0.0179
Ethyl alcohol	0.919	3.02	0.0570
Vacuum oil	0.710	7.32	1.45
Castor oil	0.550	12.86	0.58
Glycerin	0.307	16.5	11.45
Sucrose solution 20 %	0.950	2.53	0.0380
" " 40 %	0.905	3.37	0.1477
" " 60 %	0.832	7.02	2.38

These data were taken from International Critical Table, except vacuum oil, ethylen glycol and glycerin, which were measured by the author. Ethylen glycol and glycerin had a little of water. Fig. 16 and TABLE III show that in pure liquids, the better their linearities are, the smaller their fluidity variations. In solutions, however, this law is sometimes not applicable.

This fact is expected from the liquid theory. E.N.DAC. ANDRADE showed that the viscosity of normal liquids is connected with temperature in the following form,^{3),4)}

$$\eta = A e^{Q/T}, \quad (11)$$

where T is the absolute temperature, A the constant which relates to the molecular weight and density, and Q the constant which is proportional to the activation energy.

The fluidity of liquid is expressed as follows,

$$\varphi = \frac{1}{A} e^{-\frac{Q}{T}}. \quad (12)$$

Differentiating formula (12) we have

$$\frac{d\varphi}{dT} = \frac{Q}{T^2} \varphi. \quad (13)$$

Introducing the velocity of liquid flow v

$$\frac{dv}{dT} = \frac{Q}{T^2} v. \quad (14)$$

The apparatus can be constructed so that v is invariable with the nature of liquids, in that case v is determined by the configuration of the apparatus. If Q of a liquid is large, then dv/dT of the liquid is large.

Again differentiating formula (14)

$$\frac{d^2v}{dT^2} = \frac{Q-2T}{T^2} \frac{dv}{dT}, \quad (15)$$

where dv/dT shows the velocity variation with temperature, and d^2v/dT^2 the curvature of the characteristic curve between v and T . From formula (15) we see that in normal liquids, the larger dv/dT is, the larger d^2v/dT^2 is. In associated liquid d^2v/dT^2 is larger than in non-associated one.

If we want to get such a liquid as having good linearity as well as large velocity variation, we must look for it in solutions or sus-

pended system of liquids. These liquids, for example, "Uniflow", "Paraton" are practically used in machine oil.

9. Summary.

This investigation was carried out by Prof. U. NAKAYA's advice as a part of the researches on the production of the meters necessary for the agricultural physics. Several integrating thermometers of simple design which consist of glass and water were first produced, and after many improvements Apparatus No. 6 was made which can be used for practical purpose.

Apparatus No. 6 described in this paper is designed for a week run, but by making the capillary a little narrower, it is possible to produce with the present techniques an integrating thermometer for one month run.

The type of Apparatus No. 6 is suitable for the measurement of integrated value of air temperature, but small improvement will make it suitable for the measurement in case of water or soil.

In conclusion, the author wishes to express his best thanks to Prof. U. NAKAYA who directed this work throughout. The author is also indebted to Mr. T. CHIBA of Low Temperature Laboratory for his collaboration in the part of glass blowing.

References.

- 1) E. HATCHEK : *Viscosity of Liquids*, (1928), 63.
- 2) O. E. MEYER : *Wied. Ann.*, 2 (1877), 387.
- 3) E. N. DAC. ANDRADE : *Nature*, 125 (1930), 309.
- 4) E. N. DAC. ANDRADE : *Nature*, 125 (1930), 580.

Photo. 1. Apparatus No. 3.

Photo. 2. Apparatus No. 4.

Photo. 3. Apparatus No. 5.

Photo. 4. Apparatus No. 6.

Photo. 4.

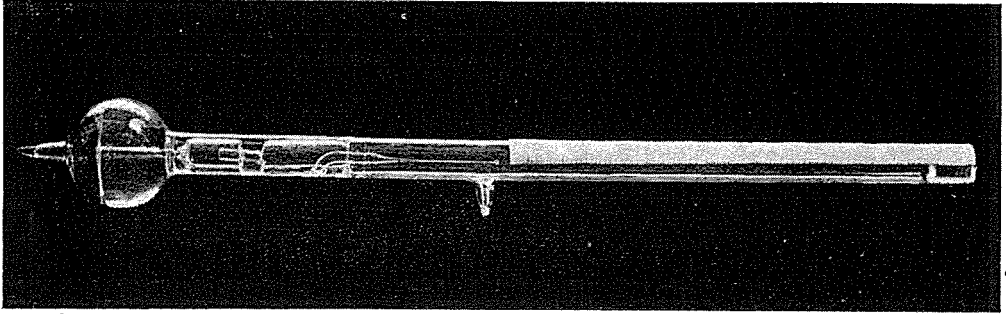

Photo. 3.

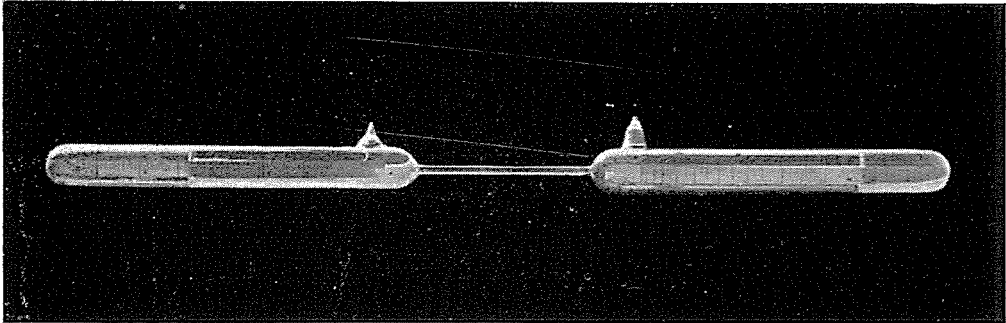

Photo. 2.

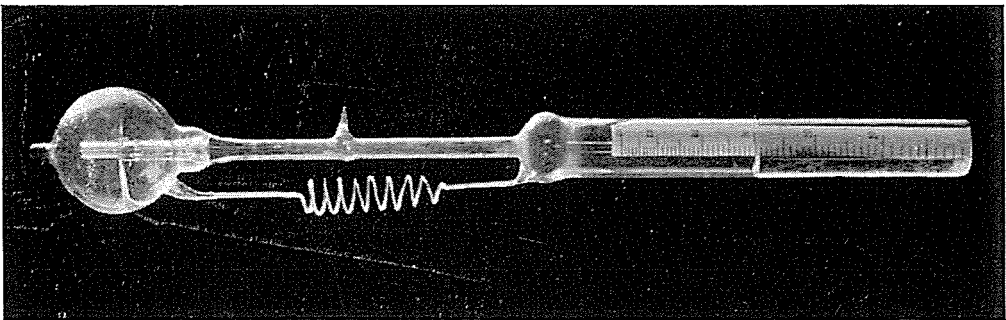

Photo. 1.

