



Title	Chemical Changes of Japanese Larch Heartwood during High-Temperature Drying : A Raman Spectroscopic Study
Author(s)	YAMAUCHI, Shigeru; HORISAWA, Sakae; IJIMA, Yasuo; KOIZUMI, Akio; DOI, Shuichi
Citation	Eurasian Journal of Forest Research, 7(1), 53-57
Issue Date	2004-02
Doc URL	http://hdl.handle.net/2115/22180
Type	bulletin (article)
File Information	7(1)_P53-57.pdf



[Instructions for use](#)

Chemical Changes of Japanese Larch Heartwood during High-Temperature Drying: A Raman Spectroscopic Study

YAMAUCHI Shigeru^{1*}, HORISAWA Sakae^{1,2}, IJIMA Yasuo¹, KOIZUMI Akio³, and DOI Shuichi¹

¹ Institute of Wood Technology, Akita Prefectural University, 11-1
Kaieisaka, Noshiro 016-0876, Japan

² Present address: Department of Environmental Systems Engineering, Faculty of Engineering,
Kochi University of Technology, 815 Miyanokuchi, Tosa-yamada 782-8502, Japan

³ Department of Forest Science, Faculty of Agriculture, Hokkaido University, Sapporo 060-8589

Abstract

Lumber containing pith sawed out of green wood of Japanese larch (*Larix leptolepis* (Sieb et Zucc.) Gord.), 105(T) mm × 105(R) mm × 4000(L) mm, was dried by a high-temperature-drying schedule. Wood samples, about 5 mm thick, were cut from the center of the long direction of the lumber. A series of FT-Raman spectra was recorded in the radial direction on the transverse sectional surface of the sample. There occurred remarkable baseline bending due to fluorescence and significant changes in Raman band intensity in the 1500-1700 cm⁻¹ region. The Raman band at 1655 cm⁻¹ assigned to the ethylenic C=C and conjugated C=O groups of lignin and phenolics decreased with increasing proximity to pith. The results of Raman measurements suggested that the condensation reactions of lignin molecules proceeded noticeably during the drying schedule and water-content is a contributing factor in the reactions. Moreover, relative intensity of Raman scattering at about 1630 cm⁻¹ developed considerably during the high-temperature drying and the band at 1600 cm⁻¹ assigned to a skeletal vibration of benzene ring seemed to increase with the baseline bending.

Key words: Raman spectroscopy, high-temperature drying, condensation, Japanese larch, lignin

Introduction

In recent years, high-temperature-drying processes that take advantage of steaming, microwave heating or high-frequency heating have been modified to supply high-quality wood as materials. However, physical and/or chemical changes (thermal degradation, elution, evaporation, etc.) will proceed somewhat during the drying, because wood is heated above 100°C even though only for a short time. In fact, a number of studies have reported low-temperature pyrolysis of wood and model compounds (Goring 1963, Ramiah and Goring 1967, Hatakeyama *et al.* 1969, Haw and Schultz 1985, Pakdel *et al.* 1989, Funaoka *et al.* 1990a; 1990b, Masuku 1992, Scholze and Meier 2001) and some pointed out chemical changes near or below 150°C. In this respect, several functions of wood as a construction material, especially durability, are likely to be reduced by high-temperature drying.

We have suggested that attractants to termite feeding are produced in Japanese larch (*Larix leptolepis* (Sieb et Zucc.) Gord.) heartwood during the steaming process (Doi *et al.* 1998) and reported that two kinds of subterranean termites preferably fed on steamed wood species (Doi *et al.* 1999). This indicates the importance of appreciating the chemical changes of wood constituents during high-temperature-drying processes. To do this, a local analysis of wood is required because it is anticipated that chemical changes do not proceed uniformly owing to temperature and water-content gradients in timber during the drying. In addition, it is

desirable that the analysis includes no wet process, since the products of the drying schedules are not always chemically stable.

The applicability of Raman spectroscopy has recently been extended to many kinds of lignocellulosics by employing Fourier transform (FT) techniques and a near infrared laser as an excitation source. We have used FT-Raman spectroscopy as a tool for local analysis of wood and wood-based materials since it probes only a small laser spot, and obtained much information on wood constituent molecules (Yamauchi *et al.* in press), and chemical behavior of adhesives (Yamauchi *et al.* 1997; 1999) and preservative (Yamauchi and Doi. 2003) in wood.

We have found that Raman spectra of Japanese larch wood significantly changed during high-temperature drying at 120°C. Although this study is the primary stage of local analysis of wood dried artificially and has not been completed yet, the Raman spectral changes were very interesting and suggestive of chemical changes in wood constituent molecules. In this paper, we present a series of Raman spectra in the radial direction of larch lumber dried at high temperatures and discuss the chemical changes on the basis of difference spectrum method.

Materials and Methods

Wood samples and drying schedules

Green wood of Japanese larch grown in Nagano Prefecture was sawed into square lumber, 105(T) mm ×

105(R) mm \times 4000(L) mm, and subsequently dried in a kiln. Drying schedule was applied: steaming at 95°C for 8 h, followed by drying at 120°C for 48 h and at 105°C for 36 h. In the drying process at 120°C, the difference in temperature between wet and dry bulbs was maintained at about 50°C. Three replications were randomly selected from the dried lumber. As illustrated in Fig. 1, wood samples for Raman measurements, about 5 mm thick, were cut from the center part in the longitudinal direction of the replications.

FT-Raman spectra

FT-Raman spectra were recorded with a JEOL JIR 7000W spectrometer connected to an RS-RSU-200 Raman module with back scattering geometry. Excitation (1064.1 nm) was provided by an Nd³⁺: YAG laser (beam power, about 200 mW); the incident laser power was 200 mW which is low enough to prevent irreversible thermal damage to the wood. The beam was focused to a diameter of about 0.5 mm on the sample surface. In order to obtain good-quality spectra, more than 1000 scans were required at about 2 cm⁻¹ intervals (spectral resolution, ca. 4 cm⁻¹). All the Raman measurements were made on earlywood in transverse sectional surfaces.

The Raman measurements of larch heartwood dried by the schedule were carried out at three points separated in the radial direction (cf. Fig. 1). When the annual ring including the measurement point b was the starting ring, point c was located in the fourth or fifth; and point d was in the ninth or tenth. The distances

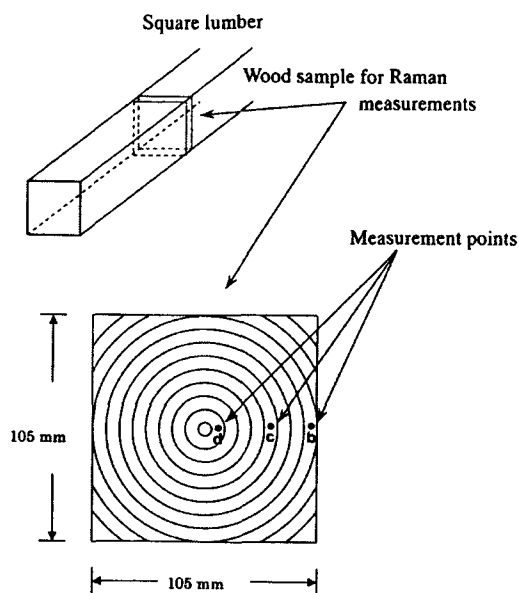

Fig. 1. Sampling and location of the wood used for Raman measurements of dried lumber.

from b to c were 23-26 mm and from b to d were 42-48 mm.

The difference spectrum method was carried out after the baseline correction of the Raman spectra of larch dried at high temperatures. The difference spectrum was calculated by subtracting the Raman spectrum X of the larch dried naturally from the corrected spectrum Y of the larch dried artificially, which is represented as spectrum Y - $k \times$ spectrum X, where k is a constant.

Results and Discussion

Figure 2 depicts Raman spectra of naturally dried larch as the control sample (spectrum a) and larch lumber dried using the schedule. The spectra b, c and d correspond to the measurement points b, c and d, respectively (cf. Fig. 1). The spectral contour obtained from the control sample showed no significant change when the location of the measurement points was varied. The Raman spectral contours of the lumber dried through the high-temperature drying are apparently different from that of the control sample and seem to change continuously in the radial direction. Similar spectral changes were observed for all the larch samples cut from the center part of lumber dried by the schedule. In contrast, although the Raman spectra of the samples near end grain also changed during the drying, the spectral changes were nearly independent of the distance from pith.

The most outstanding spectral change caused by the drying is baseline bending due to fluorescence and it increases with decreasing distance from the pith. The fluorescence may be expected to represent important information on the chemical species produced of the drying schedule. However, in general, the fluorescence observed in Raman spectra provides less information, since the lines of fluorescence are extremely broad in comparison with typical Raman bands, and further, the mechanisms of fluorescence induction from wood by laser irradiation are very intricate. Therefore, we investigate the chemical changes in Japanese larch during the high-temperature drying on the basis of the vibrational Raman bands.

As can be seen in Fig. 2, several remarkable changes in the Raman bands of larch dried by the schedule are observed in the range from 1500 cm⁻¹ to 1700 cm⁻¹. First, the relative intensity at 1655 cm⁻¹ (ν_4) decreases obviously. Secondly, a shoulder appears at about 1630 cm⁻¹ (ν_3). In addition to these, the band at about 1600 cm⁻¹ (ν_1) seems to increase relative to other Raman bands in the 1000-1500 cm⁻¹ region.

The naturally dried larch has two peaks of ν_1 and ν_4 bands and a shoulder at about 1620 cm⁻¹ (ν_2) at wavenumbers ranging from 1500 cm⁻¹ to 1700 cm⁻¹. The strongest ν_1 band is due to a skeletal vibration (ν_1) of the benzene ring. According to previous infrared spectroscopic studies of wood (Bolker and Somerville 1963, Sarkanen *et al.* 1967), the band at about 1650 cm⁻¹ is assigned to a stretching vibration of conjugated C=O group. Agarwal has reported that coniferyl alcohol

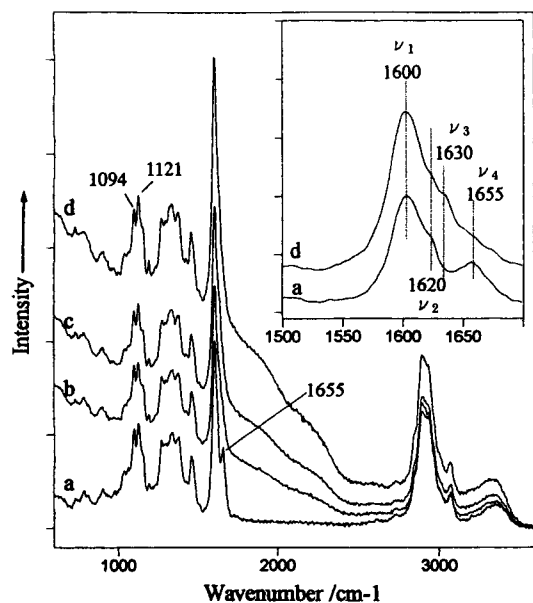

Fig. 2. FT-Raman spectra of earlywood in the sample cut from dried lumber (a) naturally dried lumber, (b) point b on transverse sectional surfaces of the sample, (c) point c, (d) point d. Refer to Fig. 1. The inset shows the Raman spectra of a and d in the region from 1400 cm^{-1} to 1800 cm^{-1} .

exhibits the Raman band at 1654 cm^{-1} due to ethylenic C=C stretching vibrations and coniferyl aldehyde has bands at 1654 and 1620 cm^{-1} attributed to the C=O and ethylenic C=C bond, respectively (Agarwal and Atalla 1993, Agarwal *et al.* 1995). Thus, both the ν_2 and ν_4 are probably attributable to lignin or phenolics in Japanese larch.

To investigate these spectral changes in more detail, we made use of the difference spectrum method. It is necessary to set up internal standard band of optical intensity when this method is used, because Raman band intensities are very sensitive to the measurement location and geometry of the wood sample. Since the ν_1 band is Raman active and hardly shifts by chemical reactions of substituent groups of an aromatic ring, it is frequently used as an internal standard for Raman intensity (method A). However, as mentioned above, it seems that an increase in relative intensity of ν_1 band is caused by the drying, and hence we adopted the Raman bands around 1100 cm^{-1} as another internal standard (method B). These Raman bands are due mainly to stretching vibrations of C-O and C-C bonds in cellulose (Agarwal and Atalla 1993, Agarwal *et al.* 1995), and are expected to accept only a small contribution from lignin. Consequently, two kinds of the difference spectra were calculated using the two internal standards (methods A and B). Based on these results, we discuss the chemical changes in larch heartwood during the drying.

Figure 3 illustrates two series of difference spectra of a larch heartwood sample dried using the schedule. For each measurement point, the same difference spectrum

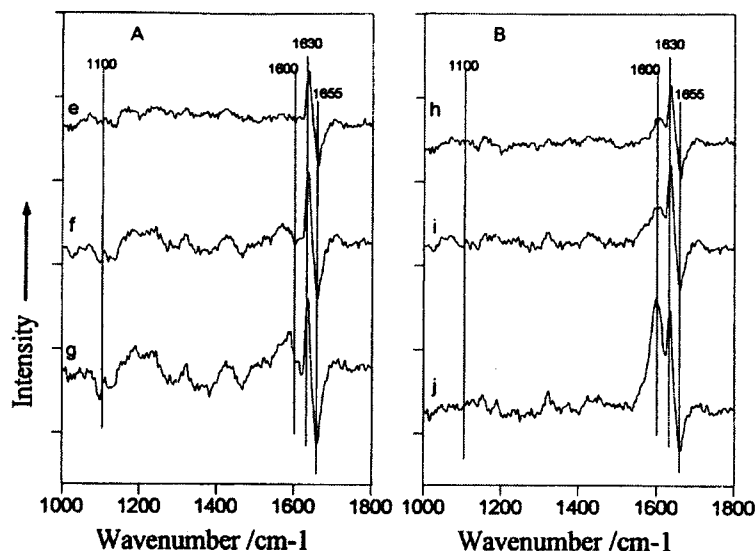

Fig. 3. Difference spectra of earlywood in the sample cut from dried lumber (e) difference spectrum calculated by subtracting Raman spectrum a from Raman spectrum b by method A, (f); c by method A, (g); d by method A, (h); b by method B, (i); c by method B, (j); d by method B. Methods A and B are used ν_1 band and the strong bands about 1100 cm^{-1} as an internal standard, respectively.

was obtained after 2-month storage under ambient conditions (23°C, 50-60%RH). Spectral changes similar to those shown in Fig. 3 were observed for all the larch samples dried by the schedule.

The reduction of ν_4 and appearance of ν_3 are common to both the series of difference spectra, although there are distinct differences in overall spectral contour between them. Moreover, the changes of ν_3 and ν_4 bands seem to have a tendency to increase as the measurement point approaches the pith of the larch sample, suggesting that water is involved in the changes because it is expected that the drying processes develop a gradient of water-content in the radial direction of the lumber except the part of end grain. Besides, no significant change in intensity of ν_2 band is observed.

A likely explanation for the reduction of ν_4 band intensity is condensation of lignin molecules. Conjugated C=O in coniferyl aldehyde unit and ethylenic C=C in coniferyl alcohol unit corresponding to the ν_4 band are located in the α -position of side chains of aromatic rings in lignin. This position is a reactive site and readily reacts with other phenyl nuclei above 120°C to form diphenylmethane type structures (Funaoka *et al.* 1990a; 1990b), indicating that the decrease of ν_3 band intensity is mainly caused by the condensation of lignin. Further, it can be presumed that the same condensation reactions occur in the phenolics molecules having the conjugated C=O and C=C groups as well as lignin. The appearance of ν_3 band can not be, however, rationalized only by the condensation reaction, because the resulting molecular structures should have no Raman-active vibration around 1630 cm^{-1} .

Assuming that a hydrogen bond is formed between conjugated C=O and OH group ($-\text{C}=\text{O}\cdots\text{H}-\text{O}-$) during the high-temperature drying, the appearance of ν_3 can be regarded as shift of ν_4 to lower wavenumbers. However, this is in conflict with the explanation based on the condensation of lignin molecules and hence the observation of ν_3 allows us to postulate that other chemical reactions also occur. It requires further study to provide a reasonable explanation for the appearance of ν_3 .

We next describe the differences between the two series. As for the difference spectra using method A (Fig. 3A), all the Raman band intensities ranging from 1000 cm^{-1} to 1500 cm^{-1} decrease evidently as the distance from the pith becomes shorter. The outline of difference spectra in this region is very similar to that of the normal Raman spectra of Japanese larch dried naturally (cf. Fig. 2a) when the vertical axis is reversed. This indicates, unless the relative intensity of ν_1 band varies significantly, that cellulose and/or hemicellulose decrease with increasing proximity to pith, since cellulose and hemicellulose make relatively large contributions to almost all the Raman bands in the 1000-1500 cm^{-1} region, especially the strong bands at around 1100 cm^{-1} (Agarwal and Ralph 1997). It is, however, unlikely that the decomposition of cellulose or hemicellulose during the drying schedule is large enough to be detected readily by the Raman

measurements.

On the other hand, as shown in Fig. 3B, the ν_1 band intensity increases as the distance from pith is decreased when the Raman band group around 1100 cm^{-1} is used as an internal standard. Benzene nuclei are very unlikely to be generated in larch during the drying processes. Therefore, the band group is seemingly inadequate as an internal standard. However, growth of definite vibrational bands arising from resonance or pre-resonance Raman effect is occasionally observed in Raman spectra, and hence the ν_1 band intensification shown in Fig. 3B may be reasonable if there are absorption bands near 1064.1 nm due to the condensed lignin. This could also be supported by the fact that the ν_1 band in Fig. 3B increases with the degree of baseline bending of the normal Raman spectra, as fluorescence is frequently linked to a pre-resonance Raman scattering. We have no experimental evidence for pre-resonance effect; however, it can be anticipated that pre-resonance phenomenon appears as the ν_1 band intensification because an activated site of the condensation reaction is the α -position of the side chain of the benzene nucleus (Funaoka *et al.* 1990a; 1990b).

In summary, the results obtained from the difference spectra showed the occurrence of several chemical changes in green wood of Japanese larch lumber having pith during the drying schedule including a maximum-temperature process at 120°C, and would indicate that one of the main reactions is the condensation of lignin and phenolics. The chemical changes have a tendency to proceed as the distance from the pith becomes shorter, suggesting that water plays an important role in the reactions. Our group is currently studying the effects of water-content and drying-temperature on Raman and infrared spectra to elucidate the chemical changes.

Acknowledgments

The authors are grateful to Dr. T. Yoshida, Nagano Prefectural Forestry Research Center, for the donation of dried larch wood lumber and helpful advice.

References

- Goring, D. A. I. (1963) Thermal softening of lignin, hemicellulose and cellulose. *Plup. Pap. Mag. Can.* 64: T517-T527.
- Ramiah, M. V. and Goring, D. A. I. (1967) Some dilatometric measurements of the thermal decomposition of cellulose, hemicellulose and lignin. *Cellulose Chem. Technol.* 1: 277-285.
- Hatakeyama, H., Nakano, J., Hatano, A. and Migita, N. (1969) Variation of infrared spectra with temperature for lignin and lignin model compounds. *Tappi* 52: 1724-1728.
- Haw, J. F. and Schultz, T. P. (1985) Carbon-13 CP/MAS NMR and FT-IR study of low-temperature lignin pyrolysis. *Holzforschung* 39: 289-296.
- Pakdel, H., Grandmaison, J. L. and Roy, C. (1989) Analysis of wood vacuum pyrolysis solid residues by diffuse reflectance infrared Fourier transform spectroscopy. *Can. J. Chem.* 67: 310-314.
- Funaoka, M., Kato, T. and Abe, I. (1990a)

- Condensation of lignin during heating of wood. *Wood Sci. Technol.* 24: 277-288.
- Funaoka, M., Shibata, M. and Abe, I. (1990b) Structure and depolymerization of acid-condensed lignin. *Holzforschung* 44: 357-366.
- Masuku, C. P. (1992) Thermolytic decomposition of coniferyl alcohol. *J. Anal. Appl. Pyrolysis* 23: 195-208.
- Scholze, B. and Meier, D. (2001) Characterization of the water-insoluble fraction from pyrolysis oil (pyrolytic lignin). Part I. PY-GC/MS, FT-IR, and functional groups. *J. Anal. Appl. Pyrolysis* 60: 40-54.
- Doi, S., Takahashi, M., Yoshimura, T., Kubota, M. and Adachi, A. (1998) Attraction of steamed Japanese larch (*Larix leptolepis* (Sieb et Zucc.) Gord.) heartwood to a subterranean termite *Copotoermes formosanus* Shiraki (Isoptera: Rhinotermitidae). *Holzforschung* 52: 7-12.
- Doi, S., Kurimoto, Y., Omura, W., Ohara, S., Aoyama, M. and Yoshimura, T. (1999) Effects of heat treatments of wood on the feeding behaviour of two subterranean termites. *Holzforschung* 53: 225-227.
- Yamauchi, S., Shibutani, S. and Doi, S. (in press) Characteristic Raman bands for *Artocarpus heterophyllus* heartwood. *J. Wood Sci.*
- Yamauchi, S., Koizumi, A., Kurimoto, Y. and Tamura, Y. (1997) Vibrational spectroscopic studies on wood and wood-based materials. II. Infrared and Raman spectroscopic investigation for MDI penetration behavior in wood. *J. Adhes. Soc. Jpn* (in Japanese with English summary). 33: 95-102.
- Yamauchi, S., Tamura, Y., Kurimoto, Y. and Koizumi, A. (1999) Vibrational spectroscopic studies on wood and wood-based materials. IV. Solvent effects of diluent on MDI penetration behavior in wood. *J. Adhes. Soc. Jpn.* (in Japanese with English summary) 35: 300-308.
- Yamauchi, S. and Doi, S. (2003) Raman spectroscopic study on the behavior of boric acid in wood. *J. Wood Sci.* 49: 227-234.
- Bolker, N. I. and Somerville, N. G. (1963) Infrared spectroscopy of lignins. Part II. Lignins in unbleached pulps. *Pulp. Pap. Mag. Can.* 64: T187-193.
- Sarkanen, K., Chang, H. M. and Ericsson, B. (1967) Species variation in lignins. I. infrared spectra of guaiacyl and syringyl models. *Tappi* 50: 572-575.
- Agarwal, U. P. and Atalla R.H. (1993) Raman spectroscopic evidence for coniferyl alcohol structures in bleached and sulfonated mechanical pulps. In: Heintner C, Scaiano JC (eds) *Photochemistry of lignocellulosic materials* (ASC symposium series 531). American Chemical Society, Washington, DC. pp. 26-44.
- Agarwal, U. P., Atalla, R.H. and Forsskahl, I. (1995) Sequential treatment of mechanical and chemimechanical pulps with light and heat. A Raman spectroscopic study. *Holzforschung* 49: 300-312.
- Agarwal, U. P. and Ralph, S.A. (1997) FT-Raman spectroscopy of wood. Identifying contributions of lignin and carbohydrate polymers in the spectrum of black spruce (*Picea mariana*). *Appl. Spectrosc.* 51: 1648-1655.