



Title	A comparative epidemiological study of hantavirus infection in Japan and Far East Russia
Author(s)	Kariwa, Hiroaki; Lokugamage, Kumari; Lokugamage, Nandadeva; Miyamoto, Hironobu; Yoshii, Kentaro; Nakauchi, Mina; Yoshimatsu, Kumiko; Arikawa, Jiro; Ivanov, Leonid I.; Iwasaki, Takuya; Takashima, Ikuo
Citation	Japanese Journal of Veterinary Research, 54(4), 145-161
Issue Date	2007-02-28
DOI	10.14943/jjvr.54.4.145
Doc URL	http://hdl.handle.net/2115/20014
Type	bulletin (article)
File Information	JJVR54-4-145.pdf



[Instructions for use](#)

A comparative epidemiological study of hantavirus infection in Japan and Far East Russia

Hiroaki Kariwa^{1,*}, Kumari Lokugamage^{1,2}, Nandadeva Lokugamage^{1,2}, Hironobu Miyamoto¹,
Kentaro Yoshii¹, Mina Nakauchi¹, Kumiko Yoshimatsu³, Jiro Arikawa³,
Leonid I. Ivanov⁴, Takuya Iwasaki⁵ and Ikuo Takashima¹

(Accepted for publication : February 5, 2007)

Abstract

Hantaviruses are causative agents of some severe human illnesses, including hemorrhagic fever with renal syndrome (HFRS) and hantavirus pulmonary syndrome (HPS). The viruses are maintained by rodent hosts, and humans acquire infection by inhaling virus-contaminated excreta from infected animals. To examine the epidemiology of hantavirus infections in Japan and Far East Russia, we conducted epidemiological surveys in these regions. In Japan, anti-hantavirus antibodies were found in four rodent species, *Clethrionomys rufocanus*, *Rattus norvegicus*, *R. rattus*, and *Apodemus speciosus*. Although no new HFRS cases have been officially reported over the past 20 years in Japan, one member of the Japan Ground Self-Defense Force did test positive for hantavirus antibody. Repeated surveys in Far East Russia have revealed that two distinct hantavirus types cause severe HFRS in this region. Hantavirus sequences identified from *A. peninsulae*, fetal HFRS cases in Vladivostok, and Amur virus are highly similar to each other (>92% identity), but they are less similar (~84% identity) to the prototypical Hantaan virus, which is carried by *A. agrarius*. Phylogenetic analysis also indicates that Amur and *A. peninsulae*-associated viruses are distinct from Hantaan virus, suggesting that *A. peninsulae* is the reservoir animal for Amur virus,

¹Laboratory of Public Health, Graduate School of Veterinary Medicine, Hokkaido University, Sapporo, 060-0818, Japan

²University of Texas Medical Branch, Galveston, Texas, U.S.A.

³School of Medicine, Hokkaido University, Sapporo 060-8638, Hokkaido, Japan

⁴Anti-Plague Station of Khabarovsk, Khabarovsk, Russia

⁵Tokyo Metropolitan Institute for Neuroscience, 2-6 Musashidai, Fuchu, Tokyo 183-8526, Japan

*Address correspondence to Hiroaki Kariwa :

Laboratory of Public Health, Graduate School of Veterinary Medicine, Hokkaido University, Sapporo, Hokkaido 060-0818, Japan

Fax : +81-11-706-5213 ; Tel. : +81-11-706-5212 ; E-mail : kariwa@vetmed.hokudai.ac.jp

which causes severe HFRS. From HFRS patients in the Khabarovsk region, we identified viruses with nucleotide sequences that are more similar to Far East virus (>96% identity) than to the Hantaan (88-89% identity) or Amur (81-83% identity) viruses. Phylogenetic analysis also indicates that the viruses from Khabarovsk HFRS patients are closely related to the Far East virus, and distinct from Amur virus.

Key Words : Hantavirus, rodent, epidemiology, epizootiology, zoonosis

Introduction

Hantaviruses are known causative agents of two human illnesses, hemorrhagic fever with renal syndrome (HFRS) and hantavirus pulmonary syndrome (HPS). The animal reservoirs of hantaviruses are various rodent species, which, when infected, are asymptomatic and carry the virus for long periods. Humans acquire hantavirus infection by inhaling virus-containing excreta from infected animals.

Hantaviruses belong to the genus *Hantavirus* of the family *Bunyaviridae*, are enveloped, and contain three single-stranded anti-sense RNA segments. The large (L), medium (M), and small (S) RNA segments encode a viral polymerase, surface glycoproteins G1 and G2, and a nucleocapsid protein (NP), respectively^{6,24,27,28}. More than 20 serotypes or genotypes of hantaviruses have been reported, and each of these viruses has a specific rodent reservoir (although one hantavirus strain has been isolated from the insectivore *Suncus murinus*)³⁶. Because the phylogenies of the viruses and their reservoir rodents are topologically identical, hantaviruses and rodents are generally believed to have co-evolved²³. The emergence of human hantavirus infections may be a result of changes in both ecological factors and human activities. The most important risk factor is close contact with rodents as a result of agricultural, forestry, or military activities¹⁵.

HFRS is caused by Hantaan virus (HTNV), Seoul virus (SEOV), Puumala virus (PUUV), and Dobrava virus (DOBV) in Eurasia; these viruses are carried by *Apodemus agrarius*, *Rattus norvegicus* and *R. rattus*, *Clethrionomys glareolus*, and *A. flavicollis*, respectively⁵. Recently, Saaremaa virus (SAAV) was identified as the causative agent of a mild form of HFRS in Europe, and *A. agrarius* was found to be the carrier^{15,22}. Serological evidence indicates that human SAAV infections occur in Estonia⁷, and SAAV may have been the cause of an HFRS outbreak in Russia in the 1990s²⁵. On the American continent, HPS is caused by Sin Nombre virus (SNV), New York virus (NYV), Black Creek Canal virus (BCCV), Bayou virus (BAYV), and Andes virus (ANDV), which are carried by *Peromyscus maniculatus*, *P. leucopus*, *Sigmodon hispidus*, *Oryzomys palustris*, and *Oligoryzomys longicaudatus*, respectively^{23,24,30}.

About 200,000 HFRS cases are reported annually throughout the world¹⁵. A wide variety of hantaviruses responsible for HFRS have been found in East Asia³³. About 50,000 to 100,000 HFRS cases are reported annually in China, where HTNV and SEOV are responsible for most of the cases³². In addition, about 100 to 200 HFRS patients are reported annually in Far East Russia, a well-known endemic area for HFRS. Recently, a distinct type of hantavirus, Amur virus (AMRV), was identified in HFRS patients in Far East Russia⁴⁰. Our previous studies revealed that *A.*

peninsulae is the reservoir animal for AMRV, and revealed antigenic and genetic evidence of a distinct hantavirus serotype^{17,18}. Furthermore, Khabarovsk and Vladivostok viruses have also been identified in the same region^{9,11}.

Two outbreaks of HFRS have occurred in Japan since the 1960s. One outbreak was reported in the Umeda district of Osaka in the 1960s^{14,35}. The source of the infection is believed to have been urban rats (*R. norvegicus*). The other outbreak was reported in various Japanese animal facilities between 1970 and 1984, and the human infections were related to contact with laboratory rats (*R. norvegicus*)^{13,19}. No new HFRS cases have been reported since 1985, although seropositive *R. norvegicus* specimens have been identified in ports and reclaimed areas in various locations throughout the country². In addition, Puumala-related viruses are widely distributed in *C. rufocanus* on Hokkaido, the northern-most major island of Japan^{10,11}.

Although we recently identified anti-hantavirus antibodies among patients with hepatitis of unknown etiology in Japan, the prevalence of the antibody is very low in the general population¹². Why Japan has relatively few HFRS patients, in spite of the highly endemic nature of the disease in the surrounding countries, is unknown. To investigate this issue, a large-scale epizootiological study targeting indigenous rodents was essential. Therefore, we carried out epizootiological surveys in rodents from various areas of Japan, including the four major islands (Hokkaido, Honshu, Shikoku, and Kyushu), to determine the endemic areas and the reservoir animals. In addition, we carried out epidemiological surveys in Vladivostok and Khabarovsk to examine the ecology of hantaviruses in Far East Russia, a highly endemic area of HFRS.

Epidemiology of hantavirus infection in Japan

Rodent epidemiology

Despite its location amidst countries endemic for HFRS, Japan has not had a reported case of HFRS for about twenty years. During this period, however, anti-hantavirus antibodies have been detected in *R. norvegicus* specimens captured in various Japanese ports. Our previous epizootiological surveys revealed that 10% of *C. rufocanus* specimens on Hokkaido have anti-hantavirus antibodies, and this species carried PUUV-related viruses^{10,11}.

Epizootiological studies of hantavirus infection among wild rodents were conducted in various locations in Japan, including the four major islands (Honshu, Kyushu, Shikoku, and Hokkaido), from 2000 to 2003. A total of 806 rodents and insectivores were captured from 11 wild settings on Honshu, Shikoku, Kyushu, and Tsushima Islands, and from six sites on Hokkaido. The geographical locations of the survey sites are shown in Figure 1. The sera were screened for anti-hantavirus antibodies using immunofluorescent antibody assay (IFA).

Serum samples from a total of 592 rodents collected from wild settings in the southern regions of Japan, including Honshu, Shikoku, Kyushu, and Tsushima Islands, were screened for antibodies to HTNV, SEOV, and PUUV. Seropositive animals were detected in Toyama and Shimane (Table 1). Of 471 *A. speciosus* individuals, five (1.1%) were seropositive by IFA. Two *R. norvegicus* individuals (5.1%) from Toyama were positive for SEOV. No antibodies to PUUV were detected in any rodent species from the southern region of Japan. Some of the IFA-positive sera from *A. speciosus* neutralized HTNV (1 : 20), but not SEOV. Using RT-PCR, we attempted

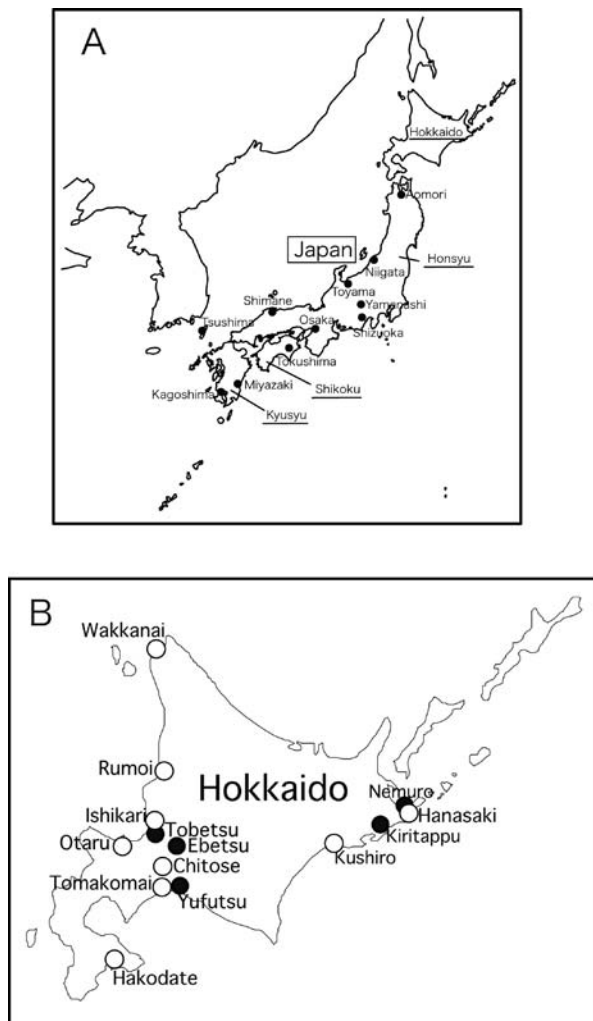

Fig. 1. Geographical location of epizootiological survey sites in Japan. A: Surveys were carried out in Aomori, Niigata, Toyama, Yamanashi, Shizuoka, Osaka, Tokushima, Shimane, Tsushima, Miyazaki, and Kagoshima prefectures. B: Surveys were carried out in Wakkani, Rumoi, Ishikari, Otaru, Tomakomai, Hakodate, Tobetsu, Ebetsu, Chitose, Yufutsu, Kushiro, Kiritappu, Hanasaki, and Nemuro on Hokkaido, the northernmost main island of Japan. Survey sites were (○) seaports and airports or (●) wild settings such as forests.

to detect viral genes in seropositive *A. speciosus*, but none of the samples produced virus-specific PCR product bands (data not shown).

In contrast, of the 214 animals captured in wild settings in Hokkaido, five out of the 153 (3.26%) *C. rufocanus* individuals from Nemuro,

Ebetsu, and Tobetsu were found to be seropositive (Table 2). No other rodent species captured in wild settings had detectable anti-hantavirus antibodies. In rodents captured in urban or semi-urban settings (ports and a Hokkaido airport), 4.5% (2/44) of *C. rufocanus*, 0.62% (2/321) of *R. norvegicus*, and 6.7% (3/45) of *R. rattus* individuals were seropositive (Table 3). *C. rufocanus* from both wild settings and the Chitose Airport had anti-PUUV IFA titers ranging from 1:32 to 1:128 and lower or undetectable anti-HTNV titers. Seropositive *R. norvegicus* and *R. rattus* were found in the port areas of Rumoi, Otaru, and Hakodate. The anti-SEOV and-HTNV IFA titers in these samples were almost equivalent, but antibodies to PUUV were undetectable.

We detected seropositive specimens of *A. speciosus* (5/482, 1.0%), *R. norvegicus* (4/364, 1.1%), *R. rattus* (3/45, 6.7%), and *C. rufocanus* (7/197, 3.6%) among 1,221 animals captured in various areas and settings of Japan. These four rodent species may play important roles as reservoir animals of hantavirus in Japan.

Further epizootiological surveys should be conducted to determine the type of hantavirus carried by *A. speciosus*. Furthermore, since seropositive *R. rattus* and *R. norvegicus* found in seaports and at the Chitose airport could be sources of human SEOV infection, their presence could pose a threat to people working in these facilities, to travelers, and to quarantine office employees. A higher seroprevalence was reported in workers employed in a reclaimed area where seropositive urban rats were detected [34]. Therefore, a larger-scale epidemiological study of hantavirus infection among people associated with the seaports and airports in Japan is warranted.

Hantavirus infection in humans

To examine the epidemiology of human

Table 1. Detection of antibodies to hantavirus by IFA among wild rodents in Honshu, Shikoku, kyushu, and Tsushima islands (2000-2003)

Rodent species	Seroprevalence at											Positive rate (%) to		
	Aomori	Niigata	Toyama	Yamanashi	Shizuoka	Shimane	Tokushima	Miyazaki	Tsushima	Kagoshima	Osaka	HTNV	SEOV	PUUV
<i>A. speciosus</i> ^{a)}	0/14 ^{b)}	0/6	4/223	0/7	0/19	1/69	0/2	0/69	0/33	0/1	0/28	5/471 (1.1)	4/471 (0.84)	0/471 (0)
<i>A. argentius</i>	—	—	0/9	0/7	0/9	—	—	0/17	0/7	—	—	0/49 (0)	0/49 (0)	0/49 (0)
<i>M. montebelli</i>	—	—	0/11	—	—	—	—	—	—	—	—	0/11 (0)	0/11 (0)	0/11 (0)
<i>E. smithi</i>	—	—	0/11	—	—	—	—	—	—	—	—	0/11 (0)	0/11 (0)	0/11 (0)
<i>M. minutus</i>	—	—	—	—	—	—	—	—	0/1	—	—	0/1 (0)	0/1 (0)	0/1 (0)
<i>M. musculus</i>	—	—	—	—	—	—	—	—	0/4	—	—	0/4 (0)	0/4 (0)	0/4 (0)
<i>R. norvegicus</i>	—	—	2/39	—	—	—	—	—	—	—	—	2/39 (5.1)	2/39 (5.1)	0/39 (0)
<i>C. dsinezumi</i>	—	—	—	—	—	—	—	0/1	—	—	—	0/1 (0)	0/1 (0)	0/1 (0)
<i>U. tapoides</i>	—	—	—	—	—	—	—	0/5	—	—	—	0/5 (0)	0/5 (0)	0/5 (0)
Total	0/14	0/6	6/293	0/14	0/28	1/69	0/2	0/92	0/45	0/1	0/28	7/592 (1.2)	6/592 (1.0)	0/592 (0)

a) Seropositive rodent species, the places where seropositive rodents found, and the number of seropositive rodents were shown in bold face.

b) Number of seropositive rodents/number of captured rodents

Table 2. Detection of antibodies to hantavirus (HTN or SEO or PUU) by IFA among rodents captured in field surveys in Hokkaido (2000-2003)

Rodent Species	Place of survey					Positive rate (%) to HTNV, SEOV, or PUUV
	Nemuro	Kiritappu	Ebetsu	Tobetsu	Yufutsu	
<i>C. rufocanus</i>	1/1 ^{a)}	0/8	3/8	1/125	0/11	5/153 (3.3)
<i>C. rutilus</i>	0/20	—	—	—	0/2	0/22 (0)
<i>A. speciosus</i>	—	—	0/1	0/1	0/4	0/6 (0)
<i>A. argentius</i>	—	—	0/1	—	0/9	0/10 (0)
<i>A. peninsule</i>	—	—	—	—	0/4	0/4 (0)
<i>R. norvegicus</i>	—	—	—	0/4	—	0/4 (0)
<i>S. caecutiens</i>	—	—	—	—	0/3	0/3 (0)
<i>S. gracillimus</i>	—	—	—	—	0/11	0/11 (0)
<i>S. unguiculatus</i>	—	—	—	—	0/1	0/1 (0)
Total	1/21	0/8	3/10	1/130	0/45	5/214 (2.3)

a) Number of seropositive rodents/number of captured rodents

Table 3. Detection of antibodies to hantavirus (HTN or PUU or SEO) by IFA among rodents captured in ports and the Chitose Airport in Hokkaido (2000-2003)

Rodent species	Place of survey									Positive rate (%) to		
	Chitose ^{a)}	Otaru	Hakodate	Rumoi	Hanasaki	Ishikari	Kushiro	Wakkani	Tomokomai	HTNV	SEOV	PUUV
<i>C. rufocanus</i>	2/39	—	—	—	—	0/5	—	—	—	2/44 (4.5)	0/44 (0)	2/44 (4.5)
<i>A. speciosus</i>	0/5	—	—	—	—	—	—	—	—	0/5 (0)	0/5 (0)	0/5 (0)
<i>R. norvegicus</i>	0/12	1/115	0/28	1/56	0/4	0/9	0/3	0/35	0/59	2/321 (0.62)	2/321 (0.62)	0/321 (0)
<i>R. rattus</i>	—	2/44	1/1	—	—	—	—	—	—	3/45 (6.7)	3/45 (6.7)	0/45 (0)
Total	2/56	3/159	1/29	1/56	0/4	0/14	0/3	0/35	0/59	7/415 (1.7)	5/415 (1.2)	2/415 (0.48)

a) Airport

Table 4. ELISA and WB for anti-hantavirus antibody positive blood donor found in the Self-defense Force in Hokkaido

No. of blood donors and positives (%)	Place	Donor	ELISA		WB		IFA		
			HTNV	PUUV	HTNV	PUUV	HTNV	SEOV	PUUV
1 / 207 (0.48%)	Chitose	# 195	0.816	0.113	(+)	NT ^{a)}	128	256	<32
		Control	0.023	0.018	(-)	(-)	<32	<32	<32

a) Not tested

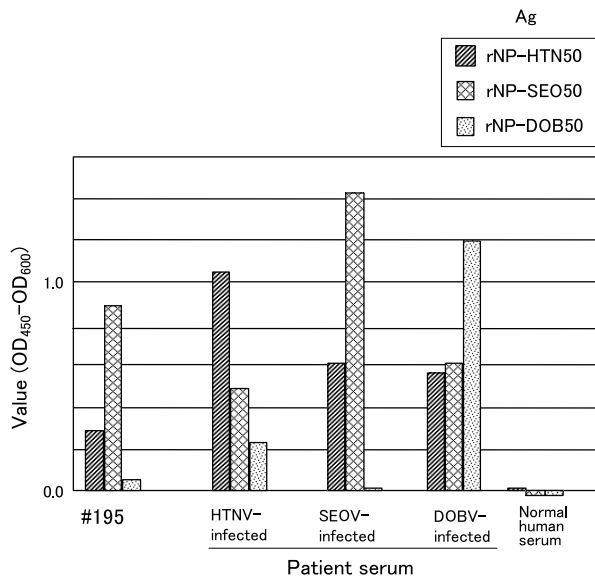

Fig. 2. Anti-hantavirus antibody detection by ELISA. IFA-positive human serum was incubated on a plate coated with recombinant hantavirus nucleocapsid proteins with serotype-specific antigenic sites. The plate was incubated with goat anti-human IgG conjugated with alkaline phosphatase. Optical density (OD) was measured at 405nm.

hantavirus infection in an at-risk population, we screened sera from the personnel of the Japan Ground Self-defense Force in Hokkaido. Of 207 blood samples examined, one sample was positive (0.48%) for anti-hantavirus antibody by IFA, with titers of 1 : 256 to SEOV and 1 : 128 to HTNV. To confirm this finding, we carried out ELISA and Western-blot analysis on the IFA-positive sample (Table 4). For ELISA, various recombinant nucleocapsid proteins (rNPs) were used as antigens to determine the type of infecting virus (Fig. 2). The IFA-positive serum reacted most strongly with an SEOV rNP (rNP-SEO50) in the

ELISA test, and the reaction pattern was similar to that manifested by serum from a confirmed SEOV-infected patient (Fig. 2), indicating that the person might also have been infected with SEOV. Although this group of people has closer contact with *C. rufocanus* than does the general population, no antibodies to PUU-related virus were detected, suggesting that PUU-related virus carried by *C. rufocanus* in this area rarely infects humans.

Epidemiology of hantavirus infection in Far East Russia

A variety of hantaviruses have been identified in HFRS patients and rodents in China and Korea^{16, 29, 31, 37, 38}. HFRS has been firmly established to be endemic to Far East Russia. However, the genetics of hantaviruses that are human pathogens have not been well defined. To determine the reason for the relatively low prevalence of hantavirus infection in humans in Japan, as compared to its surrounding countries, we conducted epidemiological surveys in Far East Russia, a highly endemic area of HFRS.

Epizootiological survey of rodents in Vladivostok

An epizootiological survey was carried out on a total of 122 rodents that were captured in a Vladivostok suburb. The results of serological screening of the rodent sera by IFA are shown in Table 5. The identified rodent species included *A. peninsulae* (70), *A. agrarius* (39), *C. rufocanus* (8), *Microtus fortis* (3), and *Tamias sibiricus* (2). Screening by IFA revealed that one *A. agrarius*

Table 5. Detection of antibodies to HTN and PUU viruses by IFA among rodents in Vladivostok

Rodent Species	No. of sera tested	Positives by IFA (%)	
		HTN	PUU
<i>A. peninsulae</i>	70	4 (5.7)	0
<i>A. agrarius</i>	39	1 (2.5)	0
<i>C. rufocanus</i>	8	1 (12.5)	1 (12.5)
<i>M. fortis</i>	3	0	0
<i>T. sibiricus</i>	2	0	0
Total	122	6 (4.9)	1 (0.8)

Table 6. Clinical history, serology, and virus detection of HFRS patients in Primorye region

Category	Patient No.	
	1	2
Age/Sex	53 years/Male	49 years/Male
Residence	Cavalerovo	Vostok
Onset of illness	May 22, 2000	June 9, 2000
Date of death	May 30, 2000	June 22, 2000
Cause of death	Gastrointestinal bleeding	Acute renal failure
IFA antibody to		
HTN 76-118	512	1024
SR 11	128	1024
PUU	32	32
PCR		
Lung	+	-
Liver	-	-
Kidney	+	-
Spleen	NA ^{a)}	+
Brain	NA	-

(2.5%), four *A. peninsulae* (5.7%), and one *C. rufocanus* (12.5%) individual had antibodies to HTN and/or PUU viruses. Lung tissues from seropositive *A. peninsulae* were subjected to RT-PCR to amplify the virus genomes. Two (#61 and #63) of the four rodents that had high anti-HTNV IFA titers (1 : 256 and 1 : 512) were positive by PCR for both the S and M segments of hantavirus.

Clinicopathology of HFRS patients

We obtained the clinical histories of two fatal cases of HFRS that occurred in the Primorye region (Table 6). These patients, who lived in villages 400 and 600 km from Vladivostok, died 8-13 days after the onset of disease from gastrointestinal bleeding and acute

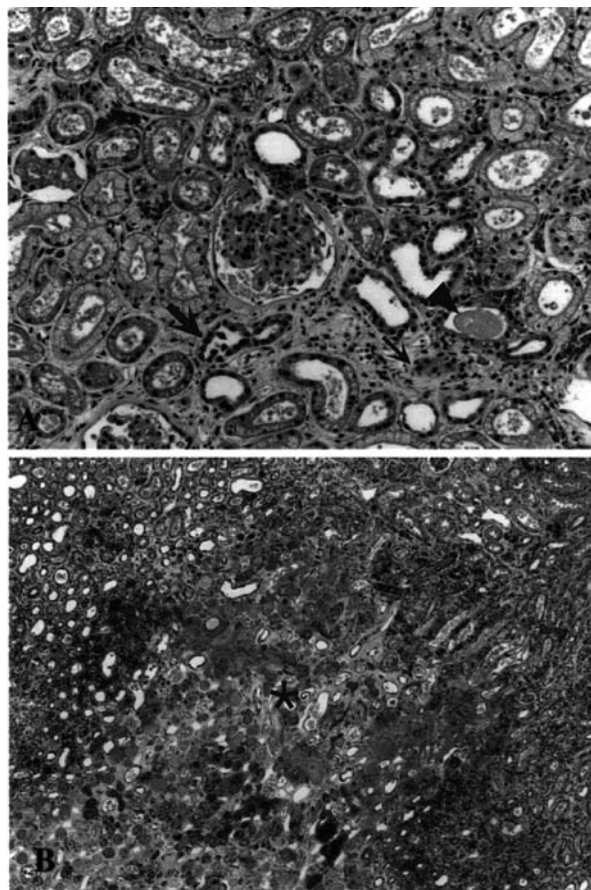

Fig. 3. Histopathological changes in kidney tissue from an HFRS patient in the Primorye region. The histological changes include interstitial edema with mild infiltration of mononuclear cells (small arrow) and the degeneration of renal tubules (large arrow) in the cortex. A: Proteinaceous casts and exudate (arrowhead) are seen in the luminae of renal tubules. Glomerular changes are inconspicuous. B: The most prominent change in the medulla is a well-defined necrotic lesion (asterisk).

renal failure. Serological screening showed that both patients were positive for hantavirus antibodies. Antibody titers to HTN and SEO viruses were apparently higher than to PUU virus. Lung, liver, kidney, spleen, and brain tissues from these HFRS patients were used for RT-PCR analysis, which showed that the lung and kidney tissues of patient No. 1 and the spleen tissue of patient No. 2 were positive for the hantaviral M segment.

Table 7. Comparison of nucleotide (2737-2969) and amino acid of M genome between those from *A. peninsulae*, HFRS patients in Primorye region, and other hantaviruses ^{a)}

	Nucleotide identities %															
	SL/AP61	SL/AP63	AMR/1169	PRI/H 1	PRI/H 2	H8205	AMR/4313	HV114	A 9	HTN76-118	Hojo	FE	NC167	DOB/SLO	SR-11	PUU
SL/AP61	—	99.5	97.8	96.1	98.2	94.8	94.3	86.2	85.7	84.4	82.7	82.7	79.3	79.3	79.7	60.3
SL/AP63	100.0	—	97.8	92.2	94.3	94.8	94.3	85.7	85.3	84.0	82.3	83.1	78.8	80.1	81.4	60.7
AMR/1169	94.8	94.8	—	96.5	98.7	95.6	95.6	86.6	86.2	84.9	83.1	81.4	79.7	80.1	79.3	60.3
PRI/H 1	100.0	100.0	94.8	—	96.9	93.5	92.2	84.0	83.6	83.1	82.3	80.6	79.3	78.8	79.3	60.3
PRI/H 2	98.7	98.7	93.5	98.7	—	94.8	94.3	85.7	85.3	84.0	82.3	81.4	78.8	79.3	78.8	59.4
H8205	100.0	100.0	94.8	100.0	98.7	—	91.3	83.6	83.1	85.3	84.9	80.6	77.1	79.3	77.1	60.7
AMR/4313	98.7	98.7	93.4	98.7	97.4	98.7	—	85.7	85.3	83.6	81.8	82.7	78.0	78.0	78.8	59.9
HV114	93.5	93.5	88.3	93.5	92.2	93.5	92.2	—	99.5	86.6	84.4	87.9	78.4	75.8	83.1	51.9
A 9	93.5	93.5	88.3	93.5	92.2	93.5	92.2	98.9	—	86.2	84.0	87.5	78.0	75.4	81.8	50.6
HTN76-118	94.8	94.8	89.6	94.8	93.5	94.8	93.5	97.4	96.1	—	94.6	88.7	79.7	78.4	76.7	59.9
Hojo	94.8	94.8	89.6	94.8	93.5	94.8	93.5	97.4	96.1	100.0	—	87.9	78.0	78.8	76.7	51.5
FE	92.2	92.2	87.0	92.2	90.9	92.2	90.9	87.9	87.5	97.4	98.7	—	75.8	73.7	78.4	59.9
NC167	86.8	86.8	80.5	86.8	85.5	86.8	85.5	89.5	88.2	90.8	90.8	88.2	—	75.4	77.5	49.3
DOB/SLO	88.3	88.3	83.1	88.3	87.0	88.3	87.0	88.3	87.0	87.0	87.0	84.4	81.6	—	75.0	59.9
SR-11	83.1	83.1	79.2	83.1	81.8	83.1	81.8	83.1	81.8	81.8	81.8	83.1	80.3	80.5	—	56.0
PUU	53.2	53.2	53.2	53.2	51.9	53.2	51.9	62.9	62.5	51.9	61.6	53.2	61.6	49.4	61.2	—

Amino acid identities %

a) Values above the diagonal are nucleotide identities and those below the diagonal show amino acid identities

To examine the histopathological changes that occur in HFRS patients, we used light microscopy to examine sections of formalin-fixed lung, liver, kidney, spleen, and brain tissues from patient No. 2, who had died of acute renal failure (Fig. 3). We were able to detect pathological changes typical of severe HFRS^(4,8,21,26), but the kidney was the only tissue that exhibited recognizable histopathological changes. The salient changes were interstitial edema with mild infiltration of mononuclear cells (small arrow) and degeneration of renal tubules (large arrow) in the cortex (Fig. 3A). Although proteinaceous casts and exudates were observed in the luminae of renal tubules (arrowhead), no glomerular changes were observed. In addition, a prominent, well-defined necrotic lesion (asterisk) was noted in the medulla (Fig. 3B). Monoclonal anti-HTNV antibodies failed to detect viral antigens in these specimens.

Sequence analysis of hantaviruses in the Primorye region

The 232-nt G2 region of the M segments of the viruses from two *A. peninsulae* speci-

mens (#61 and #63) were amplified and sequenced. These viruses were designated as Solovey/AP61/1999 and Solovey/AP63/1999 (SL viruses) to indicate the name of the village closest to the survey point, the rodent species from which the sample was taken, and the year of the epizootiological survey. We also sequenced the M segments of the genetic lineages that were identified in the two HFRS patients from the Primorye region, designated as Primorye/H1/2000 and Primorye/H2/2000 (PRI viruses). When the M segments of the SL and PRI sequences were compared with those of other hantaviruses (Table 7), SL and PRI nucleotide sequences were 92.2-99.5% identical, and their amino acid sequences were identical or nearly so (98.7-100%).

We also compared the SL and PRI M segment sequences with those of the AMR genetic lineage, which were recently identified in HFRS patients and *A. peninsulae* in Far East Russia^(17,40). The nucleotide and amino acid identities between the SL/PRI and AMR lineages were 92.2-98.7% and 93.5-98.7%, respectively. Comparison of the M segment sequences of the SL-PRI-AMR lineages with

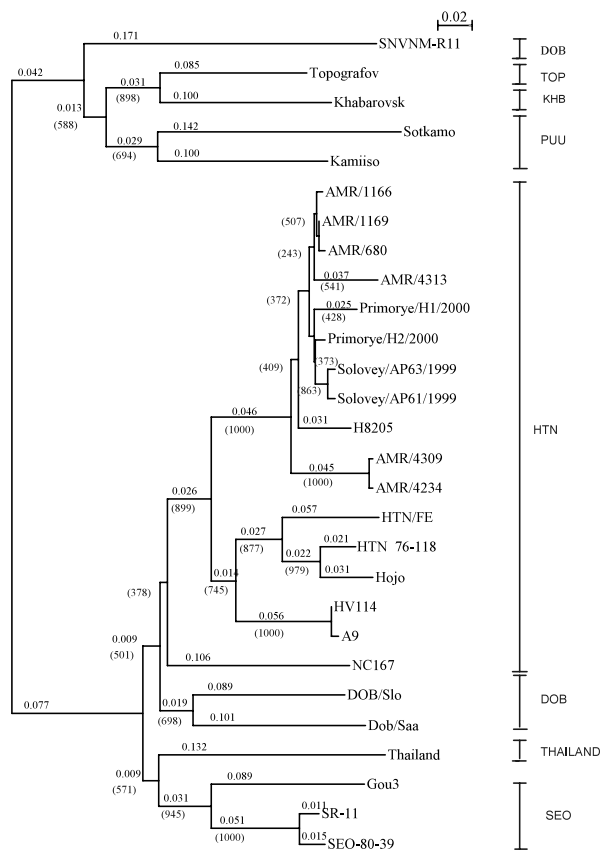

Fig. 4 . Phylogenetic trees of the partial M segment (2736-2968 nt) of hantaviruses. The trees were constructed using the ClustalX (v. 1.81) program. The numbers above the branches are distances, and those in parentheses are bootstrap support values for 1000 replicates.

that of H8205, an isolate from an HFRS patient in China, revealed that their nucleotide and amino acid sequences were 91.3-95.6 and 94.8-100% identical, respectively. Lower levels of identity were found with the Hantaan, Seoul, Dobrava, and Puumala viruses. This high level of sequence identity among the SL, PRI, AMR, and H8205 sequences suggests that some patients in Far East Russia and China acquired the infection from the Korean field mouse (*A. peninsulae*). Our results also suggest that this genetic lineage is widely distributed throughout East Asia³.

Phylogenetic analysis of the M segments of the Solovey, Primorye, and AMR sequences

Table 8 . IFA titers and PCR in acute HFRS patients in Khabarovsk

PatA No.	IFA titer to			PCR
	HTNV	SEOV	PUUV	M (G2)
1	16384	8192	16	-
2	1024	512	128	+
3	1024	512	<16	+
4	512	512	<16	-
5	256	128	<16	-
6	1024	512	64	-
7	1024	128	32	-
8	1024	128	<16	-
9	8192	8192	16	-
10	4096	512	<16	-
11	4096	256	<16	-
12	64	<16	<16	+
13	1024	512	<16	-
14	16384	2048	32	-
15	1024	512	32	-
16	64	<16	<16	-
17	512	512	<16	-
Control	<16	<16	<16	N.D. ^{a)}

a) Not done

indicates that they form a common lineage with high bootstrap support values, regardless of viral origin, but separate from the prototype HTNV lineage (Fig. 4).

Serology of acute and convalescent HFRS patients by IFA

Sera from 17 acute and 32 convalescent patients who were clinically diagnosed with HFRS in the Khabarovsk region were examined for anti-hantavirus antibody against HTNV, SEOV, and PUUV antigens using IFA. Most of the samples from the 17 acute and 32 HFRS convalescent patients had IFA antibody titers to HTNV and SEOV ranging from 1 : 128 to 1 : 16384, while titers to PUUV ranged up to 1 : 128 (Table 8, 9). However, sera from two acute (PatA12 and PatA16) and one convalescent (PatC4) patient had low or no antibody titer to all viruses (the antibody titers were 1 : 64 or lower). In 10 acute and 25 convalescent patients, the difference in

Table 9. IFA titers in HFRS convalescents in Khabarovsk

PatC No.	IFA titer to		
	HTNV	SEOV	PUUV
1	1024	512	16
2	512	256	16
3	1024	1024	32
4	<16	<16	<16
5	8192	4096	128
6	2048	1024	64
7	1024	1024	32
8	4096	2048	64
9	4096	2048	32
10	4096	512	16
11	4096	1024	64
12	2048	1024	64
13	1024	1024	16
14	1024	512	32
15	4096	1024	32
16	1024	1024	<16
17	1024	1024	16
18	4096	1024	16
19	4096	1024	32
20	8192	2048	64
21	4096	2048	64
22	8192	2048	128
23	16384	8192	128
24	2048	4096	16
25	4096	8192	32
26	4096	4096	16
27	128	128	<16
28	2048	2048	16
29	8192	4096	32
30	8192	4096	32
31	256	256	32
32	1024	1024	16
Control	<16	<16	<16

HTNV and SEOV antibody titers was no more than two-fold.

Characterization of anti-hantavirus antibodies in acute patients by ELISA

The ELISA results for the acute patients are shown in Table 10. Sera from 12 of the 17 acute patients assayed by IgG ELISA using baculovirus-expressed rNPs^{1,20,34)} had higher optical densities (OD) for HTNV (range: 0.32-2.07) than for PUUV (range: 0-0.04). Sera from 16 of 17 acute patients assayed by IgM ELISA using whole rNPs yielded higher ODs for HTNV (range: 0.71-2.40) than for PUUV (range: 0.01-0.14). Only PatA16 yielded a low OD value by both IgG and IgM ELISA (Table 10) and a low IFA titer (Table 8). Therefore, we did not consider PatA16 to be infected with hantavirus. Furthermore, we tried to distinguish the infecting virus by IgG ELISA using truncated rNPs (rNP50) (Table 10). All sera except PatA16 were positive for anti-HTNV antibodies. The ratio of rNP50s for

Table 10. Detection of anti hantavirus antibodies by ELISA in acute HFRS patients in Khabarovsk

Acute Pat No.	IgG (whole rNP)		IgM (whole rNP)		Infection	IgG (rNP50)			OD Ratio ^{b)}	Serotype
	HTNV	PUUV	HTNV	PUUV		HTNV	SEOV	DOBV		
A 1	2.07	0.01	0.96	0.02	+	1.79	0.05	-0.01	0.03	HTNV
A 2	1.02	0.04	1.94	0.14	+	0.63	0.05	-0.01	0.08	HTNV
A 3	0.67	0.00	1.71	0.02	+	0.37	-0.01	-0.01	-0.03	HTNV
A 4	0.49	0.01	1.19	0.02	+	0.49	0.01	0.00	0.02	HTNV
A 5	0.24	0.01	0.97	0.04	+	0.30	0.06	-0.01	0.21	HTNV
A 6	0.98	0.01	1.10	0.04	+	1.18	-0.01	-0.01	0.00	HTNV
A 7	0.15	0.00	1.94	0.03	+	0.45	0.07	0.00	0.15	HTNV
A 8	0.19	0.00	0.71	0.02	+	0.62	0.03	0.00	0.04	HTNV
A 9	1.50	0.02	1.48	0.03	+	1.18	0.17	0.02	0.15	HTNV
A10	0.82	0.00	1.75	0.03	+	0.48	0.07	0.01	0.14	HTNV
A11	0.75	0.01	2.24	0.08	+	0.75	0.14	0.01	0.19	HTNV
A12	0.05	0.00	1.19	0.01	+	0.23	0.09	-0.01	0.39	HTNV
A13	0.35	0.00	2.14	0.06	+	0.64	0.06	0.00	0.09	HTNV
A14	0.97	0.00	2.40	0.04	+	0.92	0.13	0.05	0.14	HTNV
A15	0.80	0.00	1.09	0.02	+	0.26	0.06	0.01	0.22	HTNV
A16	0.04	0.00	0.23	0.02	-	0.06	0.01	0.00	0.24	N.D. ^{a)}
A17	0.32	0.00	0.85	0.02	+	0.45	0.02	-0.01	0.04	HTNV
Control ^{c)}	0.00	0.00	0.08	0.02	-	0.00	0.00	0.00	N.D.	N.D.

a) Not determine

b) If the ratio of the OD of SEOV or DOBV rNP50 to that of to HTNV rNP50 was <0.7 , the serum was deemed to be from an HTNV-infected human.

c) Nomal human sera

Table 11. Detection of anti hantavirus antibodies by IgG ELISA in HFRS convalescents in Khabarovsk

Convalescent Pat No.	IgG ELISA (whole rNP)			IgG ELISA (rNP50)			OD ratio ^b	Serotype
	HTNV	PUUV	Infection	HTNV	SEOV	DOBV		
C 1	1.42	0.05	+	0.92	0.19	0.07	0.21	HTNV
C 2	0.60	0.01	+	0.56	0.19	0.02	0.35	HTNV
C 3	1.50	0.02	+	1.25	0.67	0.19	0.53	HTNV
C 4	0.02	0.01	-	0.07	0.01	-0.01	0.09	ND ^a
C 5	2.66	0.27	+	3.30	2.10	0.37	0.64	HTNV
C 6	2.21	0.11	+	2.34	0.75	0.17	0.32	HTNV
C 7	1.77	0.05	+	1.14	0.42	0.12	0.37	HTNV
C 8	2.08	0.04	+	2.71	0.91	0.12	0.34	HTNV
C 9	1.78	0.03	+	1.42	0.30	0.06	0.21	HTNV
C10	1.96	0.05	+	1.39	0.30	0.08	0.21	HTNV
C11	1.99	0.10	+	2.42	0.71	0.23	0.29	HTNV
C12	2.00	0.25	+	1.68	0.51	0.13	0.30	HTNV
C13	1.47	0.02	+	1.03	0.19	0.06	0.19	HTNV
C14	1.14	0.03	+	0.73	0.21	0.05	0.29	HTNV
C15	1.61	0.00	+	1.63	0.41	0.09	0.25	HTNV
C16	0.81	-0.01	+	0.63	0.15	0.02	0.24	HTNV
C17	1.63	0.04	+	1.30	0.28	0.08	0.22	HTNV
C18	1.81	0.06	+	1.64	0.35	0.07	0.21	HTNV
C19	2.02	0.12	+	1.78	0.53	0.12	0.30	HTNV
C20	3.01	0.26	+	2.76	0.99	0.26	0.36	HTNV
C21	3.06	0.42	+	3.01	1.54	0.51	0.51	HTNV
C22	2.90	0.36	+	2.50	0.84	0.20	0.34	HTNV
C23	3.11	0.45	+	3.42	2.46	1.03	0.72	HTNV
C24	1.92	0.04	+	1.24	0.23	0.05	0.19	HTNV
C25	2.62	0.17	+	2.36	1.02	0.18	0.43	HTNV
C26	1.94	0.02	+	1.63	0.30	0.04	0.19	HTNV
C27	0.74	0.04	+	0.47	0.07	0.01	0.14	HTNV
C28	1.91	0.03	+	1.85	0.39	0.08	0.21	HTNV
C29	2.64	0.15	+	2.60	0.50	0.11	0.19	HTNV
C30	2.36	0.12	+	2.62	0.83	0.13	0.32	HTNV
C31	1.45	0.15	+	1.00	0.29	-0.09	0.29	HTNV
C32	1.74	0.07	+	1.48	0.39	0.10	0.27	HTNV
Control ^c	0.00	0.00	-	0.00	0.00	0.00	ND	ND

a) Not determined

b) If the ratio of the OD of SEOV or DOBV rNP50 to that of HTNV rNP50 was < 0.7 , the serum was deemed to be from an HTNV-infected human.

c) Normal human sera

serum OD (second-highest value) to HTNV (highest value) was less than 0.7; therefore, all positive sera were deemed to be from patients infected with HTNV or HTN-related virus (Table 10).

Characterization of anti-hantavirus antibodies in convalescent patients by ELISA

The results of the IgG-ELISA with rNPs in convalescent patients are presented in Table 11. Most of the sera yielded higher ODs with HTNV rNPs (range: 0.6-3.11) than with PUUV rNPs (range: -0.01-0.45). Only

PatC4 yielded low ODs for both rNPs (Table 11) and a low IFA titer (Table 9), suggesting that PatC4 had not been infected with hantavirus. Using rNP50 HTNV, SEOV, and DOBV antigens, most sera reacted strongly with rNP 50 HTNV antigen, as seen for the positive-control sera from a patient infected with HTNV. The SEOV/HTNV OD ratios of most sera were less than 0.7 (Table 11). Therefore, we conclude that 31 of these 32 convalescent cases were infected with HTNV or HTNV-related virus. Sera from convalescents who recovered from HFRS 10 to 30 years ago still

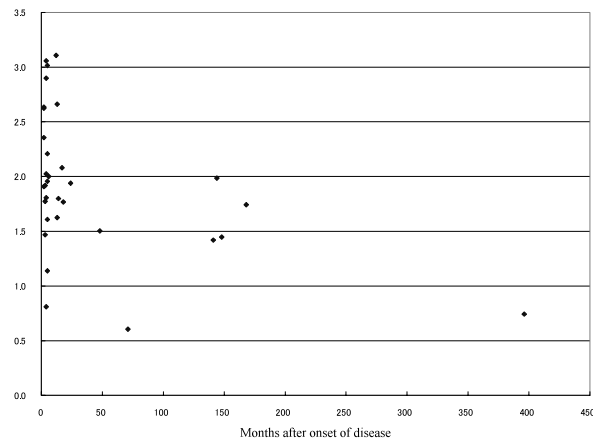

Fig. 5. Long-term persistence of anti-hantavirus IgG in convalescent HFRS patients in Khabarovsk.

yielded high ODs (Fig. 5).

Sequence analysis of hantavirus M genomes identified in acute patients

Hantavirus sequences were amplified from three acute patients (PatA2, 3, and 12) by RT-PCR. We sequenced partial M segments of the genome encoding the G2 region and compared them with those from other hantaviruses (Table 12). These sequences

from the patients were found to be very closely related, with 97.4–98.3% nucleotide identities and 98.7–100.0% amino acid identities. The sequences were most closely related to FE3844, the Far East HTNV lineage³⁹⁾, with 96.6–97.4% identity at the nucleotide level and 96.1–97.4% identity at the amino acid level. The nucleotide identities from high to low were: HTNV (88.8–89.7%), AMRV (81.0–82.7%), DOBV (76.6–77.9%), PUUV (65.3–66.7%), ANDV (65.2–66.5%), and SNV (59.1–60.3%).

Phylogenetic analysis of hantaviruses from patients with acute HFRS in the Khabarovsk region

The partial M genes were aligned using Clustal X. When a phylogenetic tree was constructed by the NJ method, PatA2, 3, 12, and FE3844 formed a phylogenetic cluster with high bootstrap support (Fig. 6). These sequences shared a common lineage with the prototype Hantaan virus (HTN76-118), but were distinct from the AMR genotype identified in Far East Russia and China (AMR7649,

Table 12. Nucleotide and amino acid identities of hantavirus sequences from acute HFRS patients in Khabarovsk with other viruses^{a)}

	Nucleotide identities (%)															
	PatA2	PatA3	PatA12	FE3844	HTN76-118	AMR7649	Solovey/AP63/1999	Primorye/H2/2000	H8205	Saaremaa/160V	SEO/SR-11	SEO/Vlad/8243	DOB/SLO	PUU/Kami-iso	AND/23	SN/NM R11
PatA2	—	97.4	97.4	96.6	89.7	82.3	82.3	81.4	81.0	78.4	77.9	77.5	74.9	65.3	66.1	59.1
PatA3	98.7	—	98.3	97.4	88.8	81.8	81.8	81.0	81.0	78.4	77.5	77.5	74.0	66.7	66.5	60.3
PatA12	100.0	98.7	—	97.4	89.7	82.7	82.7	81.8	81.0	77.9	77.1	76.6	75.3	65.8	65.2	60.3
FE3844	97.4	96.1	97.4	—	88.8	81.8	82.7	81.8	81.0	78.4	78.8	78.4	74.0	65.3	65.1	59.1
HTN76-118	100.0	98.7	100.0	97.4	—	84.4	84.4	84.4	85.7	79.2	77.1	76.2	78.8	62.6	64.2	59.1
AMR7649	93.5	92.2	93.5	90.9	93.5	—	95.7	97.0	94.4	75.9	77.9	77.1	78.9	65.2	62.5	60.2
Solovey/AP63/1999	93.5	92.2	93.5	90.9	93.5	97.4	—	97.8	94.4	76.3	81.0	80.1	79.7	63.9	62.3	57.6
Primorye/H2/2000	93.5	92.2	93.5	90.9	93.5	97.4	97.4	—	94.8	75.9	79.2	78.4	79.3	63.5	62.9	58.4
H8205	94.8	93.5	94.8	92.2	94.8	98.7	98.7	98.7	—	77.6	77.5	77.1	79.3	63.9	61.6	59.7
Saaremaa/160V	87.0	85.7	87.0	84.4	87.0	84.4	84.4	84.4	85.7	—	74.9	74.0	81.0	66.7	61.9	61.5
SEO/SR-11	81.8	81.8	81.8	83.1	81.8	81.8	81.8	81.8	83.1	77.9	—	94.8	75.3	62.9	65.4	59.7
SEO/Vlad/8243	81.8	83.1	81.8	83.1	81.8	81.8	81.8	81.8	83.1	77.9	98.7	—	76.6	63.3	65.8	58.9
DOB/SLO	87.0	85.7	87.0	84.4	87.0	87.0	87.0	87.0	88.3	90.9	80.5	80.5	—	61.6	61.9	59.3
PUU/Kamiiso	57.1	58.4	57.1	55.8	57.1	59.7	58.4	57.1	58.4	54.5	56.0	57.3	54.5	—	67.0	67.4
AND/23	55.8	57.1	55.8	55.8	55.8	61.0	59.7	58.4	59.7	53.2	58.4	59.7	54.5	68.8	—	75.0
SN/NM R11	54.5	55.8	54.5	51.9	54.5	58.4	57.1	55.8	57.1	50.6	53.2	54.5	53.2	68.8	81.8	—

Amino acid identities (%)

a) Values above the diagonal are nucleotide identities and those below the diagonal show amino acid identities

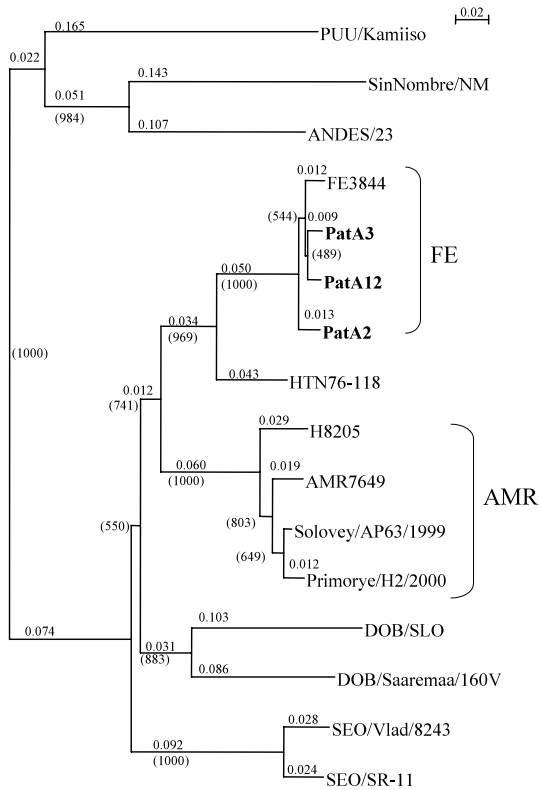

Fig. 6. Phylogenetic tree for the M segment of the hantavirus genome. The Clustal X program package was used to generate the phylogenetic trees using the NJ method with 1000 bootstrap replicates.

Solovey/AP63/1999, Primorye/H2/2000, and H 8205)^{17,40}. The virus sequences from Khabarovsk patients fell in the same cluster as Far East virus, which was identified in HFRS patients in Far East Russia³⁹. We did not identify the AMR genotype of HTNV infections in either acute or convalescent patients. Since the AMR genotype is genetically close to that of HTNV, the NP antigenicity of the two types may be similar. Therefore, we cannot exclude the possibility that some HFRS patients were infected with the AMR genotype. Antigenic characterization of the prototype HTNV, AMR and FE types is now in progress.

Although seropositive *C. rufocanus*, which carries PUUV-related virus in Japan¹⁰, inhabit this region, no evidence of PUUV or

PUUV-related virus infections was found in the acute or convalescent patients. An epidemiological survey to examine whether *C. rufocanus* carries PUUV-related virus in this region, as it does in Hokkaido, Japan, is planned.

Conclusion

Using epizootiological, clinical, pathological and sequencing studies, we identified a hantavirus carried by *A. peninsulae* as one of the causative agents of HFRS. We believe that this information may be helpful in preventing human infections not only in Far East Russia but also in eastern Asia. Since *A. peninsulae* is distributed over vast areas, including Far East Russia, China, Korea, and Japan, and hantaviruses closely related to the AMR genotype have been isolated from HFRS patients in China³⁷, considerable numbers of HFRS cases may be caused by the AMR genotype in these regions. Revealing the antigenicity of the AMR genotype glycoprotein, which is responsible for induction of neutralizing antibody and protective immunity, is very important. Since vaccine strains used in China and Korea are closely related to prototype HTNV, determining whether the antibody to HTNV can neutralize the AMR genotype is essential. Our recent cross-neutralization study revealed that the anti-sera against HTNV and AMRV had neutralizing antibody titers to the homologous virus that were ≥ 8 times higher than those to the heterologous virus. Therefore, vaccination with HTNV may be insufficient to prevent AMV infection.

Serological results indicate that FE genotype infection may be predominant in the Khabarovsk region. However, since *A. peninsulae* inhabit this region, AMR infections may also occur. Taken together, the AMR and FE genotypes are circulating in far eastern Russia, and both genotypes cause severe HFRS.

The animal reservoir of the FE genotype has not yet been determined, and *C. rufocanus* may carry a distinct hantavirus in Far East Russia. Therefore, further epizootiological studies are required to reveal the comprehensive ecology of hantaviruses in this area.

The result of this comparative epidemiological study of hantaviruses in Japan and Far East Russia suggests that the low prevalence of HFRS in Japan might be attributable to four principal factors: (1) no *A. agrarius*, and only a small number of *A. peninsulae*, the main reservoirs of HTNV and AMRV, inhabit Japan; (2) infections caused by SEOV acquired from *R. norvegicus* and *R. rattus* may be mild and easily misdiagnosed; (3) human infection by PUU-related virus from *C. rufocanus* occurs only rarely; and (4) the prevalence of hantavirus infection in *A. speciosus* is low.

Hantavirus is one of the typical rodent-borne zoonotic agents. The pathogenicity of the virus largely depends on the virus type that is carried by the specific rodent host. Therefore, the reservoir rodent species of each virus type must be determined if anti-infective strategies are to be successful. Careful epidemiological study should be conducted to evaluate the hantavirus infection risk to the public in each local setting, since additional hantaviruses that are human pathogens may yet be discovered.

Acknowledgments

We acknowledge the invaluable contributions of the Japanese and Russian people, including scientists, support staff, and students, who supported this study. Without their collaboration, we could never have accomplished this study. We especially thank Kimiyuki Tsuchiya of the Tokyo University of Agriculture, Hitoshi Suzuki of Hokkaido University, and Masahiro Iwasa of Nippon University for

providing rodent information. We appreciate the kind suggestions by Drs. Nobuo Hashimoto and Takeshi Kurata concerning epizootiological and epidemiological surveys. We also thank Mr. Michio Haseyama, Mr. Hiromi Nakai, Mr. Bisho Sakumoto, Mr. Takahara Noda of the Otaru Quarantine Office, and Ms Naomi Sakon of the Osaka Prefectural Institute of Public Health for providing rodent materials. We appreciate the kind cooperation of Drs. Hiroyuki Wakiyama and Tatsuya Fujii of the Medical School of the Japan Ground Self-Defense Force during the field survey and collection of human sera.

This study was supported by the Grants-in-Aids for Scientific Research from Japan Society for the Promotion of Science. This study was also supported by the Grants from Program of Excellence for Zoonosis Control, Hokkaido University and Ministry of Health, Labour and Welfare.

References

- 1) Araki, K., Yoshimatsu, K., Ogino, M., Ebihara, H., Lundkvist, A., Kariwa, H., Takashima, I. and Arikawa, J. 2001. Truncated hantavirus nucleocapsid proteins for serotyping Hantaan, Seoul, and Dobrava hantavirus infections. *J. Clin. Microbiol.*, 39 : 2397-2404.
- 2) Arikawa, J., Yoshimatsu, K. and Kariwa, H. 2001. Epidemiology and epizootiology of Hantavirus infection in Japan. *Jpn. J. Infect. Dis.*, 54 : 95-102.
- 3) Baek, L. J., Kariwa, H., Lokugamage, K., Yoshimatsu, K., Arikawa, J., Takashima, I., Kang, J. I., Moon, S. S., Chung, S. Y., Kim, E. J., Kang, H. J., Song, K. J., Klein, T. A., Yanagihara, R. and Song, J. W. 2006. Soochong virus: an antigenically and genetically distinct hantavirus isolated from *Apodemus peninsulae* in Korea. *J. Med. Virol.*, 78 : 290-297.

- 4) Bren, A. F., Pavlovic, S. K., Koselj, M., Kovac, J., Kandus, A. and Kveder, R. 1996. Acute renal failure due to hemorrhagic fever with renal syndrome. *Ren. Fail.*, 18 : 635-638.
- 5) Clement, J., Heyman, P., Mckenna, P., Colson, P. and Avsic-zupan, T. 1997. The hantaviruses in Europe : from the bedside to the bench. *Emerg. Infect. Dis.*, 3 : 205-211.
- 6) Elliot, R. M. 1990. Molecular biology of the *Bunyaviridae*. *J. Gen. Virol.*, 71 : 501-522.
- 7) Golovljova, I., Brussjoland, K., Lindgren, G., Vene, S., Vasilenko, V., Plyusnin, A. and Laundkvist, A. 2002. Hantaviruses in Estonia. *J. Med. Virol.*, 68 : 589-598.
- 8) Greevska, L., Polenakovic, M., Oncervski, A., Zografski, D. and Gligic, A. 1990. Different pathohistological presentations of acute renal involvement in Hantaan virus infection : Report of two cases. *Clin. Nephrol.*, 34 : 197-201.
- 9) Horling, J., Chizhikov, V., Lundkvist, A., Jonsson, M., Ivanov, L., Dekonenko, A., Niklasson, B., Dzagurova, T., Peters, C. J., Tkachenko, E. and Nichol, S. 1996. Khabarovsk virus : a phylogenetically and serologically distinct hantavirus isolated from *Microtus fortis* trapped in Far East Russia. *J. Gen. Virol.*, 77 : 687-694.
- 10) Kariwa, H., Yoshizumi, S., Arikawa, J., Yoshimatsu, K., Takahashi, T., Takashima, I. and Hashimoto, N. 1995. Evidence for the existence of Puumala-related virus among *Clethrionomys rufocanus* in Hokkaido, Japan. *Am. J. Trop. Med. Hyg.*, 53 : 222-227.
- 11) Kariwa, H., Yoshimatsu, K., Sawabe, J., Yokota, E., Arikawa, J., Takashima, I., Fukushima, H., Lundkvist, A., Shubin, F. N., Isachkova, L. M., Slonova, R. A., Leonova, G. N. and Hashimoto, N. 1999. Genetic diversities of hantaviruses among rodents in Hokkaido, Japan and Far East Russia. *Virus Res.*, 59 : 219-228.
- 12) Kariwa, H., Yoshimatsu, K., Araki, K., Murphy, M. E., Ebihara, H., Ogino, M., Mizutani, T., Arikawa, J., Chayama, K., Kumada, H. and Takashima, I. 2002. Detection of hantaviral antibodies among patients with hepatitis of unknown etiology in Japan. *Microbiol. Immunol.*, 44 : 357-362.
- 13) Kawamata, J., Yamanouchi, T., Dohmae, K., Miyamoto, H., Takahashi, M., Yamanishi, K., Kurata, T. and Lee, H. W. 1987. Control of laboratory-acquired hemorrhagic fever with renal syndrome (HFRS) in Japan. *Lab. Anim. Sci.*, 37 : 431-436.
- 14) Lee, H. W., Lee, P. W., Tamura, M., Tamura, T. and Okuno, Y. 1979. Etiological relation between Korean hemorrhagic fever and epidemic hemorrhagic fever in Japan. *Biken J.*, 22 : 41-45.
- 15) Lee, H. W., Lee, P. W., Baek, L. J. and Chu, Y. K. 1990. Geographical distribution of hemorrhagic fever with renal syndrome and hantaviruses. *Arch. Virol.*, Suppl. 1 : 5-18.
- 16) Liang, M., Li, D., Xiao, S. Y., Hang, C., Rossi, C. A. and Schmaljohn, C. S. 1994. Antigenic and molecular characterization of hantavirus isolates from China. *Virus Res.*, 31 : 219-233.
- 17) Lokugamage, K., Kariwa H., Hayasaka, D., Cui, B. Z., Iwasaki, T., Lokugamage, N., Ivanov, L. I., Volkov, V. I., Demenev, V. A., Slonova, R., Companets, G., Kushnaryova, T., Kurata, T., Maeda, K., Araki, K., Mizutani, T., Yoshimatsu, K., Arikawa, J. and Takashima, I. 2002. Genetic characterization of Hantaviruses transmitted by the Korean field mouse (*Apodemus peninsulae*), Far East Russia. *Emerg. Infect. Dis.*, 8 : 768-776.
- 18) Lokugamage, K., Kariwa, H., Lokugamage, N., Miyamoto, H., Iwasa, M. A., Hagiya, T.,

- Araki, K., Tachi, A., Mizutani, T., Yoshimatsu, K., Arikawa, J. and Takashima, I. 2004. Genetic and antigenic characterization of the Amur virus associated with hemorrhagic fever with renal syndrome. *Virus Res.*, 101 : 127-134.
- 19) Lundkvist, A. and Plyusnin, A. 2002. Molecular epidemiology of hantavirus infections. p. 351-384. In : *The Molecular Epidemiology of Human Viruses*, Leitner, T. (ed.). Kluwer Academic Publishers, Boston-Dordrecht.
- 20) Morii, M., Yoshimatsu, K., Arikawa, J., Zhou, G., Kariwa, H. and Takashima, I. 1998. Antigenic characterization of Hantaan and Seoul virus nucleocapsid proteins expressed by recombinant baculovirus : application of a truncated protein, lacking an antigenic region common to the two viruses, as a serotyping antigen. *J. Clin. Microbiol.*, 36 : 2514-2521.
- 21) Mustonen, J., Helin, H., Pietila, K., Brummer-Korvenkontio, M., Hedman, K., Vaheri, A., and Pasternack, A. 1994. Renal biopsy findings and clinicopathologic correlations in nephropathia epidemica. *Clin. Nephrol.*, 41 : 121-126.
- 22) Nemirov, K., Vaputahti, O., Lundkvist, A., Vasilenko, V., Golovljova, I., Plyushina, A., Niemimaa, J., Laakkonen, J., Vaheri, A. and Plyusnin, A. 1999. Isolation and characterization of Dobrava (Saaremaa) hantavirus carried by the striped field mouse (*Apodemus agrarius*) in Estonia. *J. Gen. Virol.*, 80 : 371-379.
- 23) Peters, C. J., Gary, L. S. and Levy, H. 1999. Spectrum of hantavirus infection : Hemorrhagic fever with renal syndrome and hantavirus pulmonary syndrome. *Annu. Rev. Med.*, 50 : 531-545.
- 24) Plyusnin, A., Vapalahti, O. and Vaheri, A. 1996. Hantaviruses : genome structure, expression and evolution. *J. Gen. Virol.*, 77 : 2677-2687.
- 25) Plyusnin, A., Nemirov, K., Apekina, V., Plyusina, A., Lundkvist, A. and Vaheri, A. 1999. Dobrava (Saaremaa) hantavirus in Russia. *Lancet*, 353 : 207.
- 26) Polenakovic, M., Grcevska, L., Gerasimovska-Tanevska, V., Oncevski, A., Dzikova, S., Cakalaroski, K. and Masin, G. 1995. Hantaan virus infection with acute renal failure. *Artif. Organs*, 19 : 808-813.
- 27) Schmaljohn, C. S., Jening, G. B., Hay, J. and Dalrymple, J. M. 1986. Coding strategy of the S genome segment of Hantaan virus. *Virology*, 155 : 633-643.
- 28) Schmaljohn, C. S., Schmaljohn, A. L. and Dalrymple, J. M. 1987. Hantaan virus mRNA : coding strategy, nucleotide sequence, and gene order. *Virology*, 157 : 31-39.
- 29) Schmaljohn, C. S., Arikawa, J., Hasty, S. E., Rasmussen, L., Lee, H. W., Lee, P. W. and Dalrymple, J. M. 1988. Conservation of antigenic properties and sequences encoding the envelope proteins of prototype Hantaan virus and two virus isolates from Korean haemorrhagic fever patients. *J. Gen. Virol.*, 69 : 1949-1955.
- 30) Schmaljohn, C. and Hjelle, B. 1997. Hantaviruses : A global disease problem. *Emerg. Infect. Dis.*, 3 : 95-104.
- 31) Shi, X. H., Liang, M. F., Hang, C. S., Gan, S., McCaughey, C. and Elliott, R. M. 1998. Nucleotide sequence and phylogenetic analysis of the medium (M) genomic RNA segments of three hantaviruses isolated in China. *Virus Res.*, 56 : 69-76.
- 32) Song, G., Hang, C. S., Liao, H. X., Fu, J. L., Gao, G. Z., Qiu, H. L. and Zhang, Q. F. 1984. Antigenic difference between viral strains causing classical and mild types of epidemic hemorrhagic fever with renal syndrome in China. *J. Infect. Dis.*,

- 150 : 889-894.
- 33) Song, G. 1999. Epidemiological progress of hemorrhagic fever with renal syndrome in China. *Chin. Med. J.*, 112 : 472-477.
- 34) Sugiyama, K., Morita, C., Matsuura, Y., Shiga, S., Komatsu, T., Morikawa, S. and Kitamura, T. 1984. Isolation of a virus related to hemorrhagic fever with renal syndrome from urban rats in a nonendemic area. *J. Infect. Dis.*, 149 : 473.
- 35) Tamura, M. 1964. Occurrence of epidemic hemorrhagic fever in Osaka city : First cases found in Japan with characteristic feature of marked proteinuria. *Biken J.*, 7 : 79-94.
- 36) Tang, Y. W., Xu, Z. Y., Zhu, Z. Y. and Tsai, T. F. 1985. Isolation of haemorrhagic fever with renal syndrome virus from *Suncus murinus*, an insectivore. *Lancet*, 1 : 513-514.
- 37) Wang, H., Yoshimatsu, K., Ebihara, H., Ogino, M., Araki, K., Kariwa, H., Wang, Z., Luo, Z., Li, D., Hang, C. and Arikawa J. 2000. Genetic diversity of hantaviruses isolated in China and characterization of novel hantaviruses isolated from *Niviventer confucianus* and *Rattus rattus*. *Virology*, 278 : 332-345.
- 38) Xiao, S. Y., Liang, M. and Schmaljohn, C. S. 1993. Molecular and antigenic characterization of HV114, a hantavirus isolated from a patient with haemorrhagic fever with renal syndrome in China. *J. Gen. Virol.* 74 : 1657-1659.
- 39) Yashina, L. N., Patrushev, N. A., Ivanov, L. I., Slonova, R. A., Mishin, V. P., Kompanez, G. G., Zdanovskaya, N. I., Kuzinai, I. I., Safronov, P. F., Chizhi-kov, V. E., Schmaljohn, C. and Netesov, S. V. 2000. Genetic diversity of hantaviruses associated with hemorrhagic fever with renal syndrome in the Far East of Russia. *Virus Res.*, 70 : 31-44.
- 40) Yashina, L., Mishin, V., Zdanovskaya, N., Schmaljohn, C. and Ivanov, L. 2001. A newly discovered variant of a Hantavirus in *Apodemus peninsulae*, Far Eastern Russia. *Emerg. Infect. Dis.*, 7 : 912.
- 41) Yoshimatsu, K., Arikawa, J., Tamura, M., Yoshida, R., Lundkvist, A., Niklasson, B., Kariwa, H. and Azuma, I. 1996. Characterization of the nucleocapsid protein of Hantaan virus strain 76-118 using monoclonal antibodies. *J. Gen. Virol.*, 77 : 695-704.