



Title	A novel membrane guanylyl cyclase expressed in medaka (<i>Oryzias latipes</i>) intestine.
Author(s)	Iio, Kaori; Nakauchi, Mina; Yamagami, Sayaka; Tsutsumi, Makiko; Hori, Hiroshi; Naruse, Kiyoshi; Mitani, Hiroshi; Shima, Akihiro; Suzuki, Norio
Citation	Comparative Biochemistry and Physiology Part B: Biochemistry and Molecular Biology, 140(4), 569-578 https://doi.org/10.1016/j.cbpc.2004.12.006
Issue Date	2005-04
Doc URL	http://hdl.handle.net/2115/13465
Type	article (author version)
File Information	iio_cbp.pdf



[Instructions for use](#)

A novel membrane guanylyl cyclase expressed in medaka (*Oryzias latipes*) intestine

Kaori Iio¹, Mina Nakauchi¹, Sayaka Yamagami¹, Makiko Tsutsumi², Hiroshi Hori²,
Kiyoshi Naruse³, Hiroshi Mitani³, Akihiro Shima³, and Norio Suzuki^{1*}

¹ Division of Biological Sciences, Graduate School of Science, Hokkaido University,
Sapporo 060-0810, Japan

²Division of Biological Science, Graduate School of Science, Nagoya University

³Department of Biological Sciences, Graduate School of Science, University of Tokyo

Short title: A novel medaka fish intestinal-specific membrane GC

The nucleotide sequence data reported in this paper have been submitted to the DDBJ, EMBL, and GenBank nucleotide sequence databases, and are available under accession number AB162944 for cDNA of *OIGC9*.

*Corresponding author: Tel. +81-11-706-4908;

FAX. +81-11-706-4461.

E-mail: norio-s@sci.hokudai.ac.jp

ABSTRACT – A novel membrane guanylyl cyclase (GC), *OIGC9*, was identified in the intestine of the medaka fish *Oryzias latipes* by the isolation of a full-length cDNA clone (3783 bp). Phylogenetic analysis indicated that *OIGC9* belongs in the enterotoxin/guanylin receptor membrane GC subfamily. The nucleotide and deduced amino acid sequences of *OIGC9* were highly homologous to those of *OIGC6*, another enterotoxin/guanylin receptor membrane GC in medaka fish. Linkage analysis of the medaka fish chromosome demonstrated that the *OIGC9* gene was mapped to LG8, which distinguishes it from the *OIGC6* gene. Determination of the cGMP concentrations in COS-7 cells expressed with *OIGC9* indicated that *Escherichia coli* heat-stable enterotoxin (STa) stimulated the activity of *OIGC9* in a concentration-dependent manner, although it did not activate the *OIGC6* expressed in the COS-7 cells. The 5'-flanking region of the *OIGC9* gene important for its transcription was partially determined using both CACO-2 cells and COS-1 cells, and was not found to be conserved with respect to either the mammalian *GC-C* gene or the *OIGC6* gene.

Key words: guanylyl cyclase, medaka fish, intestine, enterotoxin, transcription, GC-C

INTRODUCTION

Cyclic GMP is a ubiquitous intracellular second messenger produced by an ever-expanding family of receptor guanylyl cyclases (GCs), which are classified into two major forms, those found in the plasma membrane (membrane GC) and those in the cytoplasm (soluble GC) (Drewett and Garbers, 1994; Garbers and Lowe, 1994; Kusakabe and Suzuki, 2000; Loretz and Pollina, 2000; Wedel and Garbers, 2001). The soluble GC is a heme-containing heterodimer and is activated by nitric oxide or carbon monoxide (Drewett and Garbers, 1994). The membrane GC is a protein with a single membrane-spanning region and is activated by various endogenous and exogenous peptides. The membrane GC is further divided into three subfamilies, i.e., the natriuretic peptide (NP) receptors, the sensory organ-specific membrane GCs, and the enterotoxin/guanylin receptors (Seimiya et al., 1997). In mammals, cDNA for two membrane GCs, i.e., *GC-A* (the receptor for ANP/BNP) and *GC-B* (the receptor for CNP), and in medaka fish, cDNAs for three membrane GCs (*OIGC1*, *OIGC2*, and *OIGC7*) have been identified as members of the NP receptor subfamily (Takeda and Suzuki, 1999; Kusakabe and Suzuki, 2000; Loretz and Pollina, 2000; Wadel and Garbers, 2001; Yamagami et al., 2001). Similarly, cDNAs for three membrane GCs (*GC-D*, *GC-E*, and *GC-F*) and four membrane GCs (*OIGC3*, *OIGC4*, *OIGC5*, and *OIGC-R2*) have been found in mammalian and medaka fish sensory organs, respectively (Seimiya et al., 1997; Yu et al., 1997; Hisatomi et al., 1999; Kusakabe and Suzuki, 2000).

In contrast to the two abovementioned subfamilies, only a single membrane GC has been classified in the enterotoxin/guanylin receptor subfamily in both mammals (*GC-C*) (Schulz, et al., 1990) and medaka fish (*OIGC6*) (Mantoku et al., 1999).

Recently, cDNA fragments for two membrane GCs (*GC-C1* and *GC-C2*) have been cloned from the intestine of the European eel *Anguilla anguilla* (Comrie et al., 2001). Furthermore, it has been demonstrated that the expression of the *GC-C2* gene in the intestine was increased by 100% following the transfer of fresh water-acclimated eels to sea water; moreover, the developmental maturation of yellow eels into pre-migratory silver eels resulted in a significant increase in the intestinal expression of the *GC-C2* gene (Comrie et al., 2001). On the other hand, it has been reported that the mammalian *GC-C* gene is expressed exclusively in the intestine, and its translation product is activated by both endogenous peptides (guanylin and uroguanylin) and exogenous peptides (for example, *Escherichia coli* heat-stable enterotoxin, STa) (Schulz et al., 1990; Currie et al., 1992; Hamra et al., 1993; Vaandrager and De Jonge, 1994a). Upon STa-binding to the extracellular domain of mammalian *GC-C*, the intracellular cyclase catalytic domain converts GTP to cGMP, causing secretory diarrhea in humans, particularly among children.

In this study, we found that the medaka fish *Oryzias latipes* possesses the second intestine-specific membrane GC (*OIGC9*), although the expression of *OIGC9* as well as *OIGC6* in adult fish did not change with alterations in environmental salinity. Here, we report that using a recombinant COS-7 cell expression system, *OIGC9* is activated by STa, and *OIGC6* is activated by endogenous ligand(s). In this report, we also describe the 5'-flanking region of the *OIGC9* gene that is required to drive its transcription; this region was found to be unique and exhibited no similarity to corresponding regions of the *OIGC6* gene (Nakauchi and Suzuki, 2003) and the human *GC-C* gene (Swenson et al., 1999; Di Guglielmo et al., 2001).

MATERIALS AND METHODS

Animals

Mature adult medaka fish *O. latipes* of the orange-red variety were purchased from a local dealer. The fish were kept in indoor tanks under artificial reproductive conditions (10-h dark, 14-h light cycle; 27°C) and were fed Otohime B2 (Nisshin Seifun Group Inc., Tokyo, Japan).

Isolation of a cDNA clone for a novel intestine-specific membrane GC

The first strand of cDNA was synthesized by reverse-transcription polymerase chain reaction (RT-PCR) using the total RNA (2 µg) prepared from medaka fish intestine by the acid guanidinium thiocyanate-phenol-chloroform extraction method (Chomzynski and Sacchi, 1987). A cDNA fragment for a novel intestine-specific membrane GC, named *OIGC9*, was amplified by PCR using the cDNA as the template with a combination of three degenerate oligonucleotide primers (P2: 5'-GAYATHGTGNGGNTTYAC-3'; P6: 5'-GTRTTNACNGTRTCNCC-3'; and P7: 5'-ARRCARTANCKNGGCAT-3') synthesized based on the amino acid sequences of three regions (DIVGFT, GDTVNT, and MPRYCL, respectively,) conserved in known membrane GCs. The following conditions were used for the first PCR amplification: 90 sec at 94°C, 35 cycles of 30 sec at 94°C, 1 min at 41°C and 1 min at 72°C, and 5 min at 72°C. The following conditions were used for the second PCR amplification: 90 sec at 94°C, 35 cycles of 30 sec at 94°C, 1 min at 39°C and 1 min at 72°C, and 5 min at 72°C. The 3'- and 5'-portions of the cDNA were amplified by PCR using each adapter-specific primer (3'-RACE inner primer, 3'-RACE outer primer, 5'-RACE inner primer, or 5'-RACE outer primer) and the gene-specific antisense oligonucleotide

primers according to the manufacturer's protocol (the FirstChoice™ RLM-RACE Kit; Ambion, Austin, TX, USA). To determine the full-length cDNA sequence of *OIGC9*, the PCR products were cloned into pBluescript II KS(-) (Stratagene, La Jolla, CA, USA) and sequenced using the dideoxy chain termination method (Sanger et al., 1977) and an ABI PRISM 3100 Genetic Analyzer (Applied Biosystems, Foster City, CA, USA).

Molecular phylogenetic analysis

The amino acid sequence (residues 820-932) of *OIGC9* was compared with those of known GCs using Clustal W program (Thompson et al., 1994) and the sequence editor SeqPub (Gilbert, Indiana University, Bloomington, IN, USA). The rooted phylogenetic tree was constructed using the aligned sequence and the neighbor-joining algorithms in the PROTRAS program of PHYLIP ver.3.572 (Felsenstein, 1989) and the Clustal W program (Saitou and Nei, 1987). For the neighbor-joining analysis, the evolutionary distance was estimated using Kimura's empirical method for protein distances (Kimura, 1983). The following DDBJ accession numbers for the sequences were used: **AB004921** (*OIGC1*); **AB030274** (*OIGC2*); **AB000899** (*OIGC3*); **AB000900** (*OIGC4*); **AB000901** (*OIGC5*); **AB007192** (*OIGC6*); **AB023489** (*OIGC7*); **AB054814** (*OIGC8*); **AB015874** (*OIGC-R2*); **U21101** (sea urchin spermatozoa GC); **D49837** (*Xenopus* GC-C); **NM_004963** (human GC-C); **D17513** (porcine GC-C); **X14773** (rat GC-A); **M26896** (rat GC-B); **M55636** (rat GC-C); **L37203** (rat GC-D); **L36029** (rat GC-E); **L36030** (rat GC-F); and **AF024622** (rat GC-G). Complementary DNA sequences of fugu mGC1 and fugu mGC2 were predicted from their genome sequences (Ensemble Gene ID: fugu mGC1; SINFRUG00000151673 and fugu mGC2; SINFRUG00000140444) in the DOE Joint Genome Institute database

(http://bahama.jgi-psf.org/fugu/html/fugu_funsheet.html) and were translated into the putative amino acid sequences.

Expression of the *OIGC9* transcripts in medaka fish organs

Total RNA (1 µg) prepared from various adult medaka fish organs (brain, eye, kidney, intestine, ovary, testis, gill, liver, and spleen) was reverse-transcribed using an oligo (dT) primer according to the manufacturer's protocol (SuperScriptTM III First-Strand Synthesis System for RT-PCR; Invitrogen, Carlsbad, CA, USA). The cDNA fragment containing the 3' untranslated region (UTR) of *OIGC9* was amplified by PCR (5 min at 96°C, 25 or 28 cycles of 30 sec at 96°C, 30 sec at 60°C and 1 min at 72°C, and 10 min at 72°C) using a pair of gene-specific primers:

5'-GGCTGTCACAGAGAATCCAAG-3' and 5'-CCTGACCAGCTCACACAAGG-3'

(291-bp product). As an internal control, *OICA1* (the cytoplasmic actin gene of the medaka fish, DDBJ accession number **D89627**) was also amplified using following primers: 5'-GGGTCTTTCATGACGGGC-3' and

5'-CAAGTCGGAACACATGTGCA-3' (100-bp product). Each cDNA fragment was separated by electrophoresis on 1.5% agarose gel in 1x TAE (0.35%(v/v) glacial acetic acid, 10 mM EDTA, 40 mM Tris base, pH 8.0) and then each fragment was stained with ethidium bromide (EtBr).

Effect of environmental salinity on the expression of the *OIGC9* gene

Thirty individual medaka fish were divided into two groups and transferred into plastic aquaria filled with fresh water (FW) and 50% artificial seawater (SW), respectively. After 24-h acclimation to 50% SW, the fish were transferred into 100% SW (Inoue and Takei, 2002). In order to expose the fish to similar stress conditions,

the fish in the FW group were also transferred into another plastic aquarium filled with FW. To examine the change in the mRNA levels, at 24 h, 3 days, and 5 days after transfer of the FW fish (n=5 in each case) in each group, each fish was dissected, and the total RNA was extracted from the intestine. The total RNA was reverse-transcribed using the SuperScriptTM III First-Strand Synthesis System (Invitrogen), and the cDNA fragment containing the 3' untranslated region (UTR) of *OIGC9* or *OIGC6* was amplified by PCR with a pair of gene-specific primers: 5'-GGCTGTCACAGAGAATCCAAG-3' and 5'-CCTGACCAGCTCACACAAGG-3' for *OIGC9* (291-bp product), and 5'-ACAACGGAGAACGTCCAGCGT-3' and 5'-TGCAGCCATGTTGCCTCGTTAC-3' for *OIGC6* (271-bp product) under the following conditions: 5 min at 96°C, 23 cycles of 30 sec at 96°C, 30 sec at 60°C and 1 min at 72°C, and 10 min at 72°C. The cDNA fragments separated by electrophoresis on 1.5% agarose gel in 1x TAE, and then the fragments were stained with EtBr.

Linkage analysis of the *OIGC9* gene

To assign the locus of the *OIGC9* gene to the linkage group, polymerase chain reaction-restriction fragment length polymorphism (PCR-RFLP) was carried out using gene-specific primers (5'-AGATTTACCACAAGCTCGTT-3' and 5'-CCTTCCACAGCCTCCTGAAG-3') according to a procedure described in a previous paper (Naruse et al., 2000).

Assay of guanylyl cyclase activity

The open reading frame (ORF) of *OIGC6* (amino acids 1-1075) or *OIGC9* (amino acids 1-1076) was amplified by PCR using gene-specific primers (for *OIGC6*: 5'-ATGAGCACATTTAACTTGTGGCTG-3' and

5'-CTAAAGGAAGGTGCTCAGCGTG-3'; and for *OIGC9*:

5'-ATGTACGGCTTACAGAGTTTACTG-3' and

5'-TCACAGGTAAGTACTTGGATTCTC -3'). The following PCR conditions were used: 5 cycles of 10 sec at 98°C, 30 sec at 63°C and 5 min at 72°C, 5 cycles of 10 sec at 98°C, 30 sec at 61°C and 5 min at 72°C, 25 cycles of 10 sec at 98°C, 30 sec at 59°C and 5 min at 72°C, and 10 min at 72°C. The PCR products were subcloned into a pCR[®]3.1 vector (Invitrogen), and the construct containing *OIGC6* or *OIGC9* was transfected into COS-7 cells.

The COS-7 cells were cultured in Dulbecco's modified Eagle's medium (DMEM) supplemented with 10% heat-inactivated fetal bovine serum (FBS) (HyClone[®], Logan, UT, USA) and 1x penicillin-streptomycin-glutamine (Invitrogen) under a humidified 5% CO₂ atmosphere. The cells were plated at 5x10⁵ cells per well in a 24-well plate and were cultured for 24 h before transfection. The cells were then transfected by lipofectamin with the plasmid DNA (0.8 µg of DNA/2 µl of LIPOFECTAMIN 2000 (LF2000) Reagent per well) according to the manufacturer's protocol (Invitrogen). As a control, the pCR 3.1 vector was transfected alone. Forty-eight hours after transfection of the respective construct DNA, the cells were washed with 200 µl DMEM containing 10% IBMX, and were treated with various concentrations (10⁻⁵ M-10⁻¹¹ M) of STa or medaka fish intestine extract in 200 µl DMEM containing 10% IBMX. After incubation at 37 °C for 40 min, the medium was removed, and the cGMP concentration was determined by PROTOCOL 3 of the Enzyme immunoassay (EIA) System (Amersham Pharmacia Biotech., Buckinghamshire, UK) according to the manufacturer's protocol.

The intestines obtained from 20 mature adult individual medaka fish were homogenized in a 300-µl homogenization buffer containing 10% glycerol, 100 mM

NaCl, 1 mM EDTA, and 50 mM HEPES, pH 7.4. The homogenate was centrifuged at 10,000 x g for 30 min at 4°C, and the resulting supernatant was used as the intestine extract. The protein concentrations were determined using a BCA™ protein assay kit (PIERCE, Bonita Springs, FL, USA) according to the manufacturer's protocol.

Isolation and characterization of the 5'-flanking region of the *OIGC9* gene

To isolate genomic DNA clones containing the 5'-flanking region of the *OIGC9* gene, the medaka fish BAC library (approximately 4.5×10^5 plaques) (Matsuda et al., 2001) was hybridized with an *OIGC9* cDNA fragment (nucleotides 3432-3724) as a probe, which was labeled with digoxigenin (DIG)-dNTP using DIG-High Prime (Boehringer Ingelheim, Heidelberg, Germany) according to the manufacturer's protocol. The BAC DNAs of positive clones were purified using a HiSpeed™ Plasmid Midi Kit (QIAGEN, Hilden, Germany) and were analyzed by Southern hybridization using the DIG-labeled probe, after being digested by *Bam*HI or *Eco*RI. The nucleotide sequence of the longest 5'-flanking region of the *OIGC9* gene was determined as described above and was analyzed with GENETYX-MAC/version 7.2.0 (Software Development, Tokyo, Japan).

The transcriptional factor binding sites in the 5' flanking region of the *OIGC6* and *OIGC9* genes, as well as in human *GC-C*, were predicted using Parallel Protein Information Analysis system (<http://mbs.cbrc.jp/papia/papiaJ.html>).

Promoter analysis of the 5'-flanking region of the *OIGC9* gene

The transcription initiation site of the *OIGC9* gene, determined by a procedure described in a previous paper (Yamamoto and Suzuki, 2002), was 238 bp upstream of the putative start codon and was designated as +1. Various genomic DNA fragments

(nucleotides -4016 to +253, -3216 to +253, -2439 to +253, -1485 to +253, -1153 to +253, -1153 to +253, -948 to +253, -810 to +253, -745 to +253, -702 to +253, -638 to +253, -583 to +253, -453 to +253, -374 to +253, and -55 to +253) were cloned respectively into the *KpnI*-*Bam*HI sites in a pGL3-enhancer luciferase vector (Promega, Madison, WI, USA) and were purified using the Qiagen Lambda Midi Kit (QIAGEN).

CACO-2 cells (a human intestine-derived cell line) or COS-1 cells (an African green monkey kidney-derived cell line) were cultured in Dulbecco's modified Eagle's medium (DMEM) supplemented with 10% heat-inactivated FBS (HyClone) and 1x penicillin-streptomycin-glutamine (Invitrogen) under a humidified 5% CO₂ atmosphere. For the reporter-enzyme assay, 5x10⁵ CACO-2 cells or 4x10⁵ COS-1 cells were plated per well in a six-well plate, and the cells were cultured for 24 h before transfection. A plasmid construct (20 µg) consisting of the *OIGC9* promoter region and the luciferase gene was co-transfected with pSV-β-galactosidase (20 µg) (Promega) into CACO-2 cells or COS-1 cells by the calcium phosphate co-precipitation method (Graham and van der Eb, 1973). After 48-h culture, the cells were lysed in Reporter Lysis Buffer (Promega), and the luciferase activity was assayed using a Luciferase Assay System (Promega) according to the manufacturer's protocol. β-galactosidase activity was also assayed in order to normalize it with respect to variations in transfection efficiency.

RESULTS

Isolation and characterization of a cDNA clone encoding *OIGC9*

The isolation and determination of a full-length cDNA clone of *OIGC9*, obtained by RT-PCR and repeated 3'- and 5'-RACE, indicated that the *OIGC9* cDNA is 3,783 bp in length, consisting of a 238-bp 5'-untranslated region (UTR), a 3,225-bp open reading

Fig. 1

frame (ORF), and a 316-bp 3'UTR with a poly (A)⁺ tail. Termination codons occur in all three frames upstream of the putative initiation codon (ATG), and nucleotides around the putative initiation codon fit within the preferred sequence for initiation of protein synthesis in eukaryotic mRNA (Kozak, 1983). The ORF of the *OIGC9* cDNA predicts a protein of 1075 amino acids, which contains an amino-terminal signal sequence of 24 amino acids (Fig. 1). Cleavage of the signal sequence would result in a mature protein of 1051 amino acids. The mature protein of *OIGC9* is composed of a large extracellular domain (residues 1-426), a single membrane-spanning domain (residues 427-451), a protein kinase-like domain (residues 471-747), and a cyclase catalytic domain (residues 779-1006). The phylogenetic analysis demonstrated that *OIGC9* belongs to the heat-stable enterotoxin/guanylin receptor subfamily (Fig. 2). 42%, 65%, and 84% similarity was observed between the following regions of *OIGC9* and *OIGC6*: the extracellular domain, the protein kinase-like, and the cyclase catalytic domains, respectively.

Fig. 2

As shown in Fig. 3, RT-PCR using total RNA isolated from various adult medaka fish organs (brain, eye, kidney, intestine, ovary, testis, gill, liver, and spleen) demonstrated that *OIGC9* was expressed exclusively in the intestine; this finding reflects a similarity to the expression patterns of *OIGC6* (Mantoku et al., 1999). Environmental salinity did not affect the extent of expression of either *OIGC6* or *OIGC9* in the intestine (data not shown). The gene mapping study revealed that the *OIGC9* gene was mapped to the linkage group (LG) 8 on the medaka fish genome.

Fig. 3

cGMP accumulation in COS-7 cells expressed with *OIGC6* or *OIGC9* upon treatment of STa and medaka fish intestine extract

The medaka fish intestine extract increased cGMP concentrations by 24.8-fold in

Fig. 4

COS-7 cells transfected with the *OIGC6* cDNA, as compared to the values obtained without the extract; however, no obvious increases were detected with regard to the cGMP concentrations in the COS-7 cells transfected with the *OIGC9* cDNA (Fig. 4A). In contrast, STa at 1×10^{-6} M led to a 100.6-fold increase in the cGMP concentration in COS-7 cells transfected with the *OIGC9* cDNA, as compared to the values observed without STa, but no significant increases were detected in the cGMP concentrations in the COS-7 cells transfected with the *OIGC6* cDNA (Fig. 4B). In both cases, the cells transfected with the empty vector did not show any obvious changes in the cGMP concentration in response to the extract or to STa at 1×10^{-6} M. The increases in the cGMP concentration in cells transfected with the *OIGC9* cDNA were concentration-dependent when the STa concentration ranged from 1×10^{-11} M to 1×10^{-6} M, whereas STa administered within a range of 1×10^{-11} M to 1×10^{-6} M had no effect on the cGMP concentrations in the COS-7 cells transfected with the *OIGC6* cDNA or the empty vector (Fig. 5).

Fig. 5

Characterization of the promoter in the *OIGC9* gene using mammalian cell lines

Analysis of the promoter activity of the *OIGC9* gene using the various *OIGC9*-luciferase fusion gene constructs and CACO-2 cells or COS-1 cells demonstrated that in the case of the CACO-2 cells, a -4016/+243 construct showed the highest luciferase activity (Fig. 6). The luciferase activity gradually decreased with deletions from -4016 to -2067, but this activity gradually increased with deletions from -2067 to -948 to almost the same value obtained with a -2439/+243 construct (Fig. 6A). Further deletion down to -745 resulted in further reduction in luciferase activity, but the -702/+243 and -638/+243 constructs showed almost the same luciferase activity as that observed with the -2439/+243 construct. By deletions from -638 to -374, luciferase

Fig. 6

activity decreased, and a -55/+243 construct showed almost no luciferase activity at all. On the other hand, although there was measurable luciferase activity with COS-1 cells, this activity remained at much lower levels than that seen with CACO-2 cells. Moreover, deletions from -2439 to -2067 and from -374 to -55 did not reflect any significant changes in luciferase activity with COS-1 cells, whereas deletions from -702 to -374 slightly increased luciferase activity (Fig. 6B).

DISCUSSION

In this study, we isolated the cDNA (*OIGC9*) for a novel intestine-specific membrane GC from the medaka fish *O. latipes*, which belongs to the heat-stable enterotoxin/guanylin receptor subfamily (Fig. 2). In a previous study (Mantoku et al., 1999), we isolated and characterized the cDNA (*OIGC6*) for a medaka fish homologue of mammalian GC-C; thus, *OIGC9* is the second known medaka fish homologue of mammalian GC-C. Mammalian GC-C is known to be expressed exclusively in the intestine and to mediate the local effects of two endogenous intestinal peptides, guanylin and uroguanylin, on intestinal electrolyte and water transport, epithelial cell growth and differentiation, and possibly also renal diuretic/natriuretic responses to uroguanylin (Nakazato, 2001; Steinbrecher et al., 2002). It is also known that STa leads to secretory diarrhea in humans, and it activates mammalian GC-C expressed in COS-7 cells (Schulz et al., 1990). In this study, a COS-7 expression system was used to demonstrate that STa activates *OIGC9* in a concentration-dependent manner, but it does not activate *OIGC6* (Figs. 4, 5). In addition, we found that the intestine extract, which was expected to contain endogenous ligands, activated *OIGC6*, but not *OIGC9* (Fig. 4). These findings suggest that the structural differences in the extracellular

domains of OIGC6 and OIGC9 are responsible for differential activation by endogenous ligand(s) and STa, although it has been reported that the structure of STa is similar to that of mammalian endogenous ligands, namely, guanylin and uroguanylin (Nakazato; 2001).

The mechanism of stimulating the guanylyl cyclase activity of mammalian GC-C by STa has been accounted for from a number of perspectives, such as (1) the importance of glycosylation sites (Asn¹⁹⁵ and Asn⁴⁰²) in the extracellular domain for the proper folding of the domain for STa-binding (Nandi et al., 1996; Ghanekar et al., 2004), (2) the phosphorylation of Ser¹⁰⁵² in the intracellular domain by PKC for conformation changes suitable for an active form upon binding of STa to the extracellular domain (Wada et al.; 1996), (3) oligomerization (Vaandrager et al., 1994b; Vijayachandra et al., 2000), (4) the interaction of the carboxyl termini with PDZ protein (Scott et al., 2002; Zhang and Wang; 2003), and (5) ATP-binding to the kinase-like domain (Bhandari et al., 2001). Among these features, it was found that the following were conserved in both OIGC6 and OIGC9: a region for mediating oligomerization, the PDZ domain, and a Lys residue in the kinase-like domain for stabilizing the ATP-binding site (Fig. 1). In addition to these conserved features, the residues SPTFIWK, which are thought to be involved in STa binding in porcine GC-C (Hasegawa et al., 1999a and 1999b), were also conserved in both OIGC6 and OIGC9, suggesting that the STa binding site identified in porcine GC-C may not be related to the differential activation of OIGC6 and OIGC9 by STa-binding. On the other hand, as shown in Fig. 1, two glycosylation sites (Asn¹⁹⁵ and Asn⁴⁰²) are conserved in OIGC9, but not in OIGC6. In addition, a RNNSFQK sequence (residues 1050-1056 in OIGC9), which corresponds to the consensus phosphorylation sequence (RXXS¹⁰⁵²XK) found in porcine GC-C, is found in OIGC9, but not in OIGC6. These structural differences between OIGC6 and OIGC9

may contribute to an explanation of the differential binding and subsequent activation of *OIGC6* and *OIGC9* by possible endogenous ligand(s) and STa.

Several studies have shown that the intestinal transcriptional regulator CDX2 mediates intestinal epithelial cell-specific expression of the mammalian *GC-C* gene (Di Guglielma et al., 2001), and that hepatocyte nuclear factor-4 (HNF-4) is a key regulator of mammalian *GC-C* expression in the intestine (Swenson et al., 1999). In a previous study, we demonstrated that the AGACCTTTGC nucleotides in the 5'-flanking region of the *OIGC6* gene play a critical role in the transcription of the gene (Nakauchi and Suzuki, 2003). Since the size of the human genome is almost four times that of the medaka fish (Tanaka, 1995), the human genome can be considered to have undergone more dynamic change in the evolutionary process, which would in turn suggest that transcriptional regulatory mechanisms on the genome may also have varied substantially. Indeed, the regions which have been reported to regulate the intestinal cell-specific expression of human *GC-C*, differ from the regions identified in the *OIGC6* gene. In this study, we demonstrated that these potential transcriptional regulatory sequences were not found in the 5'-flanking region of the *OIGC9* gene (Fig. 7), thus suggesting that the transcriptional regulatory mechanisms of the *OIGC9* gene differ from those of the *OIGC6* and mammalian *GC-C* genes.

Fig. 7

To gain a better understanding of the *OIGC9*-specific mechanisms of transcription, we analyzed the promoter/enhancer activity of the *OIGC9* gene using two cell lines of different origin, CACO-2 and COS-1 cells. The luciferase activity measured with the COS-1 cells remained much lower than that observed in the case of the CACO-2 cells (Fig. 6), suggesting that the transcriptional activity of the *OIGC9* gene is higher in the intestine than in the kidney. This interpretation of the results receives support from the present findings showing that the *OIGC9* gene is expressed exclusively in the intestine

(Fig. 3). With respect to the luciferase activity measured with COS-1 and CACO-2 cells, the regions between -2439 and -2067, -702 and -374, and -374 and -55 are likely to be involved in the type of transcriptional regulation specific to CACO-2 cells (Fig. 6), suggesting that these sequences are not similar to those of the *OIGC6* gene, nor to those of the human *GC-C* gene (Fig. 7). Moreover, these sequences might be required for intestine-specific transcription and may contain potential transcription factor binding sites.

In this study, we demonstrated that the *OIGC9* gene was mapped to linkage group (LG) 8 on the medaka fish genome, which is different from the linkage group (LG19) mapped for the *OIGC6* gene (Naruse et al., 2000). In addition, as regards this difference, it has been suggested that the genes on LG8 and LG19 share the same ancestral chromosome (proto-chromosome 2) (Naruse et al., 2004). Therefore, we expect that the *OIGC6* and *OIGC9* genes were duplicated from the same ancestral gene; this interpretation accounts, at least in part, for the similarity of the two genes at the amino acid level. However, the following two factors suggest that after gene duplication, the nucleotide sequences of both genes, and the subsequent biological functions of the translation products of both genes, were altered independently: 1) the observation regarding the differential activation of *OIGC6* and *OIGC9* by possible endogenous ligand(s) and STa, and 2) the lack of similarity in the 5'-flanking region between the *OIGC6* and *OIGC9* genes. Here, it should be mentioned that the European eel *A. anguilla* has two *GC-Cs* (*GC-C1* and *GC-C2*), and increased expression of the *GC-C2* gene in the intestine was observed with increases in environmental salinity (Comrie et al., 2001), whereas in this study, no transcriptional changes were observed in either the *OIGC6* gene or the *OIGC9* gene with changes in environmental salinity (data not shown). This discrepancy may reflect the fact that the

medaka fish *O. latipes* has long been accustomed to living in fresh water, although it is also able to survive in seawater for a short period of time; therefore, the *OIGC6* and *OIGC9* gene transcription products are thought to have lost functions related to osmotic control during the process of evolution.

ACKNOWLEDGEMENTS

We are grateful to the staff members of the Center for Advanced Science and Technology, Hokkaido University, for the use of their laboratory facilities. We would also like to thank Dr. Minoru Tanaka, Hokkaido University, for the use of his laboratory facilities. This study was supported by a Grant-in-Aid for Scientific Research from the Ministry of Education, Science, Sports, and Culture of Japan (no. 11236202) and by the National Project on Protein Structural and Functional Analyses.

REFERENCES

- Bhandari R., Srinivasan, N., Mahaboobi, Ghanekar, Y., Suguna, K. and Visweswariah, S.S., 2001. Functional inactivation of the human guanylyl cyclase C receptor: Modeling and mutation of the protein kinase-like domain. *Biochem.* 40, 9196-9206.
- Chomczynski, P., Sacchi, N., 1987. Single-step method of RNA isolation by acid guanidinium thiocyanate-phenol-chloroform extraction. *Anal. Biochem.* 162, 156-159.
- Comrie, M.M., Cutler, C.P. and Cramb, C.G., 2001. Cloning and expression of two isoforms of guanylate cyclase C (GC-C) from the European eel (*Anguilla anguilla*). *Comp. Biochem. Physiol.* 129B, 575-586.
- Currie, M.G., Fok, K.F., Kato, J., Moore, R.J., Hamra, F.K., Duffin, K.L. and Smith, C.E., 1992. Guanylin: an endogenous activator of intestinal guanylate cyclase. *Proc. Natl. Acad. Sci. USA.* 89, 947-951.
- Di Guglielmo, M.D., Park, J, Schulz, S. and Waldman, S.A., 2001. Nucleotide requirements for CDX2 binding to the *cis* promoter element mediating intestine-specific expression of guanylyl cyclase C. *FEBS Lett.* 507, 128-132.
- Drewett, J.G. and Garbers, D.L., 1994. The family of guanylyl cyclase receptors and their ligands. *Endocrine Rev.* 15, 135-162.
- Felsenstein, J., 1989. PHYLIP-phylogeny interference package (version 3.2). *Cladistics.* 5, 164-166.
- Garbers, D.L. and Lowe, D.G., 1994. Guanylyl cyclase receptors. *J. Biol. Chem.* 269, 30741-30744.
- Ghanekar, Y., Chandrashaker, A., Tatu, U. and Visweswariah, S.S., 2004. Glycosylation

- of the receptor guanylyl cyclase C: role in ligand binding and catalytic activity. *Biochem. J.* 379, 653-663.
- Graham, F.L. and van der Eb, A.J., 1973. A new technique for the assay of infectivity of human adenovirus 5 DNA. *Virology.* 52, 456-467.
- Hamra, F.K., Forte, L.R., Eber, S.L., Pidhorodeckyj, N.V., Krause, W.J., Freeman, R.H., Chin, D.T., Tompkins, J.A., Fok, K.F., Smith, C.E., Duffin, K.L., Siegel, N.R. and Currie, M.G., 1993. Uroguanylin: structure and activity of a second endogenous peptide that stimulates intestinal guanylate cyclase. *Proc. Natl. Acad. Sci. USA.* 90(22), 10464-10468.
- Hasegawa, M., Hidaka, Y., Matsumoto, Y., Sanni, T. and Shimonishi, Y., 1999a. Determination of the binding site on extracellular domain of guanylyl cyclase C to heat-stable enterotoxin. *J. Biol. Chem.* 274: 31713-31718.
- Hasegawa, M., Hidaka, Y., Wada, A., Hirayama, T. and Shimonishi, Y., 1999b. The relevance of N-linked glycosylation to the binding of a ligand to guanylate cyclase C. *Eur. J. Biochem.* 263, 338-345.
- Hisatomi, O., Honkawa, H., Imanishi, Y., Satoh, T. and Tokunaga, F., 1999. Three kinds of guanylyl cyclase expressed in medaka photo-receptor cells in both retina and pineal organ. *Biochem. Biophys. Res. Commun.* 255, 216-220.
- Inoue, K. and Takei, Y., 2002. Diverse adaptability in *Oryzias* species to high environmental salinity. *Zool. Sci.* 19, 727-734.
- Kimura, M., 1983. *The Neutral Theory of Molecular Evolution.* Cambridge University Press, Cambridge.
- Kozak, M., 1983. Comparison of initiation of protein synthesis in procaryotes, eucaryotes, and organelles. *Microbiol. Rev.* 47, 1-45.
- Kusakabe, T. and Suzuki, N., 2000. The guanylyl cyclase family in medaka fish *Oryzias*

- latipes*. Zool. Sci. 17, 131-140.
- Loretz, C.A. and Pollina, C.P., 2000. Natriuretic peptides in fish physiology. Comp. Biochem. Physiol. 125B, 169-187.
- Mantoku, T., Muramatsu, R., Nakauchi, M., Yamagami, S., Kusakabe, T. and Suzuki, N., 1999. Sequence analysis of cDNA and genomic DNA, and mRNA expression of the medaka fish homolog of mammalian guanylyl cyclase C. J. Biochem. 125, 476-486.
- Matsuda, M., Kawato, N., Asakawa, S., Shimizu, N., Nagahama, Y., Hamaguchi, S., Sakaizumi, M. and Hori, H., 2001. Construction of a BAC library derived from the inbred Hd-rR strain of the teleost fish, *Oryzias latipes*. Genes. Genet. Syst. 76, 61-63.
- Nandi, A., Mathew, R. and Visweswariah, S.S., 1996. Expression of the extracellular domain of the human heat-stable enterotoxin receptor in *Escherichia coli* and generation of neutralization antibodies. Protein. Expt. Purif. 8, 151-159.
- Nakauchi, M. and Suzuki, N., 2003. Promoter analysis of a medaka fish intestinal guanylyl cyclase gene. FEBS Lett. 536, 12-18.
- Nakazato, M., 2001. Guanylin family: new intestinal peptides regulating electrolyte and water homeostasis. J. Gastroenterol. 36, 219-225.
- Naruse, K., Fukamachi, S., Mitani, H., Kondo, M., Matsuoka, T., Kondo, S., Hanamura, N., Morita, Y., Hasegawa, K., Nishigaki, R., Shimada, A., Wada, H., Kusakabe, T., Suzuki, N., Kinoshita, M., Kanamori, A., Terada, T., Kimura, H., Nonaka, M. and Shima, A., 2000. A detailed linkage map of medaka, *Oryzias latipes*: Comparative genomics and genome evolution. Genetics. 154, 1773-1784.
- Naruse, K., Tanaka, M., Mita, K., Shima, A., Postlethwait, J. and Mitani, H., 2004. A medaka gene map: The trace of ancestral vertebrate proto-chromosomes revealed

- by comparative gene mapping. *Genome Res.* 14 (5), 820-828.
- Saitou, N. and Nei, M., 1987. The neighbor-joining method: a new method for reconstructing phylogenetic trees. *Mol. Biol. Evol.* 4, 406-425.
- Sanger, F., Nicklen, S. and Coulson, A.R., 1977. DNA sequencing with chain-terminating inhibitors. *Proc. Natl. Acad. Sci. USA.* 74, 5463-5467.
- Schulz, S., Green, C.K., Yuen, P.S. and Garbers, D.L., 1990. Guanylyl cyclase is a heat-stable enterotoxin receptor. *Cell.* 63, 941-948.
- Scott, R.O., Thelin, W.R. and Milgram, S.L., 2002. A novel PDZ protein regulates the activity of guanylyl cyclase C, the heat-stable enterotoxin receptor. *J. Biol. Chem.* 277, 22934-22941.
- Seimiya, M., Kusakabe, T. and Suzuki, N., 1997. Primary structure and differential gene expression of three membrane forms of guanylyl cyclase found in the eye of the teleost *Oryzias latipes*. *J. Biol. Chem.* 272(37), 23407-23417.
- Steinbrecher, K.A., Work, S.A., Rudolph, J.A., Witte, D.P. and Cohen, M.B., 2002. Targeted inactivation of the mouse guanylin gene results in altered dynamics of colonic epithelial proliferation. *Am. J. Pathol.* 161, 2169-2178.
- Swenson, E.S., Mann, E.A., Jump, M.L. and Giannella, R.A., 1999. Hepatocyte nuclear factor-4 regulates intestinal expression of the guanylin/heat-stable toxin receptor. *Am. J. Physiol.* 276, G726-G736.
- Takeda, K. and Suzuki, N., 1999. Genomic structure and expression of the medaka fish homolog of the mammalian guanylyl cyclase B. *J. Biochem.* 126(1), 104-114.
- Tanaka, M., 1995. Characteristics of medaka genes and their promoter regions. *Fish. Biol. J. Medaka.* 7, 11-14.
- Thompson, J.D., Higgins, D.G. and Gibson, T.J., 1994. CLUSTAL W: Improving the sensitivity of progressive multiple sequence alignment through sequence

- weighting, position-specific gap penalties and weight matrix choice. *Nucleic Acids. Res.* 22, 4673-4680.
- Yamagami, S., Suzuki, K. and Suzuki N., 2001. Expression and exon/intron organization of two medaka fish homologs of the mammalian guanylyl cyclase A. *J. Biochem.* 130(1), 39-50.
- Yamamoto, T. and Suzuki, N., 2002. Promoter activity of 5'-flanking regions of medaka fish soluble guanylate cyclase alpha 1 and beta 1 subunit genes. *Biochem. J.* 361 (Pt2), 337-345.
- Yu, S., Avery, L., Baude, E. and Garbers, D.L., 1997. Guanylyl cyclase expression in specific sensory neurons: A new family of chemosensory receptors. *Pros. Natl. Acad. Sci.* 94, 3384-3387.
- Vaandrager, A.B. and De Jonge, H.R., 1994a. Effect of cyclic GMP on intestinal transport. *Adv. Pharmacol.* 26, 253-283.
- Vaandrager, A.B., van der Wiel, E., Hom, M.L., Luthjens, L.H., de Jonge, H.R., 1994b. Heat-stable enterotoxin receptor/guanylyl cyclase C is an oligomer consisting of functionally distinct subunits, which are non-covalently linked in the intestine. *J. Biol. Chem.* 269 (23), 16409-16415.
- Vijayachandra, K., Guruprasad, M., Bhandari, R., Manjunath, U.H., Somesh, B.P., Srinivasan, N., Suguna, K. and Visweswariah, S.S., 2000. Biochemical characterization of the intracellular domain of the human guanylyl cyclase C receptor provides evidence for a catalytically active homodimer. *Biochem.* 39 (51), 16075-16083.
- Wada, A., Hasegawa, M., Matsumoto, K., Niidome, T., Kawano, Y., Hidaka, T., Padilla, P.I., Kurazono, H., Shimonishi, Y. and Hirayama, T., 1996. The significance of Ser¹⁰²⁹ of the heat-stable enterotoxin receptor (STaR): relation of STa-mediated

guanylyl cyclase activation and signaling by phorbol myristate acetate. *FEBS Lett.* 387, 75-77.

Wedel, B. and Garbers, D., 2001. The guanylyl cyclase family at Y2K. *Annu. Rev. Physiol.* 63, 215-233.

Zhang, M. and Wang, W., 2003. Organization of signaling complex by PDZ-domain scaffold proteins. *Acc. Chem. Res.* 36, 530-538.

Figure legends

Fig. 1. Alignment of the amino acid sequences of OIGC9, OIGC6, eel GC-C2, human GC-C, and porcine GC-C. Asterisks below the sequences indicate identical amino acid residues among the three proteins. Gaps in the sequences are indicated by dashes (-). Open boxes indicate conserved Cys residues (Yu et al., 1997) and Lys residues (Bhandari et al., 2001). N-linked glycosylation sites are underlined, and the glycosylation sites at Asn¹⁹⁵ and Asn⁴⁰² in porcine GC-C (Hasegawa et al., 1999a) are indicated by open circles. The region in porcine GC-C, which is reported to be involved in STa binding, is indicated by a shadowed box (Hasegawa et al., 1999b). The predicted oligomerization region in human GC-C is indicated by a double underline. The consensus phosphorylation sequence containing the target site (Ser¹⁰⁵²) of PKC identified in porcine GC-C (Wada et al., 1996) is indicated by a broken line. The amino acid number indicates the position relative to the first Met, considered as 1.

Fig. 2. Molecular phylogenetic relationship of various membrane GCs in medaka fish and the rat. The amino acid sequences of the catalytic domains of known membrane GCs were subjected to phylogenetic analysis. (I), (II), and (III) indicate the enterotoxin/guanylin receptor, the sensory organ-specific receptor, and the natriuretic peptide receptor subfamily, respectively.

Fig. 3. Detection of the *OIGC9* transcript in various organs of adult medaka fish by RT-PCR analysis. RT-PCR was carried out for 25 and 28 cycles. Medaka fish cytoplasmic actin gene (*OICAI*) was amplified as an internal control.

Fig. 4. GC activity in COS-7 cells transfected with *OIGC6* or *OIGC9* with medaka fish intestine extract (A) and STa (B). Black boxes indicate the cGMP concentrations after treatment of the cells with the intestine extract (27 μg protein/ μl) or with 1×10^{-6} M STa. White boxes indicate the cGMP concentrations in cells not exposed to the extract or to STa. Transfection and cGMP assay were performed in four independent experiments, and the values are expressed as the mean \pm S.D.

Fig. 5. The accumulated cGMP in COS-7 cells transfected with *OIGC6* or *OIGC9* after treatment with STa. *OIGC6*, *OIGC9*, or empty pCR[®]3.1 vector is indicated by , , or , respectively. Transfection and cGMP assay were performed in four independent experiments, and the values are expressed as the mean \pm S.D.

Fig. 6. Summary of the *cis*-regulatory element analysis of the *OIGC9* gene using various *OIGC9*-luciferase fusion gene constructs. (A) The luciferase activity measured in CACO-2 cells. (B) The luciferase activity measured in COS-1 cells. The structures of the fusion genes are indicated at the left of the Figure. The white boxes show the 5'-leader sequence of the *OIGC9* gene. An untranscribed 5'-flanking region of the *OIGC9* gene is indicated by a horizontal line. The numbers indicate the nucleotide position relative to the transcription initiation site (+1). The luciferase fusion gene constructs were cotransfected with β -galactosidase control plasmid. On the right side of the Figure, the black boxes with a bar indicate the luciferase activity in the cells. The data represent the luciferase-to- β -galactosidase ratio and are expressed by the fold-activation relative to the empty luciferase construct, considered as 1.

Fig. 7. Schematic drawing of several consensus sequences for several transcription

factors found in the 5'-flanking region of the *OIGC6* gene, the *OIGC9* gene, and the human *GC-C* gene. Closed ellipses, open ellipses, closed boxes, and open boxes represent the consensus sequence for the GATA transcription factor family, hepatocyte nuclear factor-4 (HNF-4), Cdx2, and the CCAAT/enhancer binding protein family (C/EBP), respectively. The TATA box is indicated as an open triangle. The numbers below the line indicate the length of the 5'-flanking sequence.

Putative signal sequence

01GC9 --MYGLQSLFLPLGLTMTLVSNMDLDCLESNPRYTMVNVLLLENTYEWSPFVQEAIVEAGAIKKDAENRKAGLNFLLTANYNWFNTNLYNRQCCSSGCGVAVLKKLHNTGEVCTML 117
01GC6 ---MSTFNLMLSVLCAGFVGSASCVQVCGQCMDGITVNVILLEDEESFWSLKYVGGQILEAEKDDAAINAEGMEFNLTYNPEFGNTLLYRQRCCITSSCGAEKLNKLMVTEGLCCVVL 116
eel
human MKTLLLDLALWSLLFPQGMWLSFSSQVSNCHNGSYEISVLMMGNSAFAPPELKNLEDAVNGLEIVRGRLLQAGLANVTYNATEFMYSDGLIHNSGSCSSGCGGLDLRLKISNAQRMGCVLI 120
porcine MKTPLLALALWSLLQLGLTFWPSVSSQVSNCHNGSYEISVLMMNNSAFPELNDLKNVNEGVNIVRQRLLLEAGLTVTYNATEFVYSEGVYKSSSCSSGCGGLDLRLTISSEKRMGCVLI 120

01GC9 GPCCTFATFQVLDVEEIGLSLSIXVISAGSFGLSGCIYKPKLTRLILPARKVSDSLVYFFN-EKNMLKP-IWEKAVYKKSNNVTEDCFWYNNALAEPSAHPASSK-KREMLRGEELKAL 234
01GC6 GPCCTYATFAIADDEKGFNLSTPIISAGSFGSGCIYAMNLQRLLPARKISDFINFWK-EKFTIKP-KWRTAVYKRPQNT-EDCLWYIGALEAD-GRFLVNV-SRTILRHPGDKLDVFL 231
eel ---KAYLTRLPLPARKISNLEIFELRFESSLK-PWEAVYVYKPKENS-EDCFWYINALDAPSAFNSAI-TRKVLKPEELHSAF 81
human GPCCTYSTFQY---LDTELSYPMISAGSFGLSGCIYKTELTRLMSPARLMLYLVNFKWTDLPFKTYSWTSYVYKNGTET-EDCFWYINALEASVYFSEHIGLKVIVLRQDKFQDIL 236
porcine GPCCTYSTFQY---LDTELSYPMISAGSFGLSGCIYKTELTRLMSPARLMLYLVDFVKNVNFPPKPSWNTAVYVFKSTYSS-EDCFWYINALEAGVYFSPKLSFKEMLRGNEEFQNIL 236

01GC9 TSK-YRFSNIFLCCSVDDIVSIGKLAGQPH-EDTIFILIDLINPEYIIN-TTSLAPMRDVLVVTLP-PRNYVN--ESNSTENNTINDYVAGYHSDALLFGEVLRKRLMS----QHVPL 343
01GC6 DSQENRSTNLPILCCSPTDLKEVKNISPAADNLDILFLIDLINVDVYIIN-TTSMPEMRNVLVLTMPDTRTYI--KPDLTGNDTNDYMAAYHADVALLVGGVMDRIAIRNPAEMQMEY 346
eel ERK-NRKSNIILCCCTPEDVANLIDNGRLE-PDIVLILLIDLNHYEYHSA-AGSPA-MSNVLVITMPNIRNYTEGWTNGTLP-EMNDYVAGYHGDVHLFGLVLRQKMLYEGSVEENAS 198
human MDH-NRKSNIILCCGPEFLYKLG--DRAVAEDVIIIVLVDLNDQYLEDNVTADPYMKNVLVLTSPGNSLLNS-SFSRNLSPTRKDFALAYLNGILLPGHMLKIFLENGE--NITTP 349
porcine MDQ-NRKSNIILCCGAPETVHTLKG--GRAVAEDVIIIVLVDLNDHYFMDNVTADPYMKNVLVLTLPENSVNS-SFSKDLVLKNDFTLAYMNNVLLPGHMLKIFLEKRE--DVITS 349

transmembrane

01GC9 SDT-PPGNISFEGMAGNVLYDEYGRDRWETFIYTSQAQSKYETLSVFDTSQNTIIMWHDSPTLPWKDGQLPGDEP-ENTEDLSTQDIIVIVLGVSVVVTALIAIFRQNRKERLMQ-M 460
01GC6 VNTNYPNYSFNGIGGHYKLDSDGRDWNFSVIYITSTDN-KYKILFSDFTENETKQMDPSPTFIWK-ALPDDKP--GSELETQDIIVIVLGVVAVVATLAFIFRQNRKDRRLR-K 462
eel VEN-PPKNTSFGSGLDGQVLDDEHGDVDSNFSVYMSSTDSQYKLVLEFDTSNTFVVDANPTWHKSSRLPDRPAEQVLLATQDIIVIVLGVSVVVTALIAIFRQNRKIDRQAQ-K 314
human KFAHAFNLTTFEGHMGVPTLDDCGDINDTMTFLYTSVDTSKYVLLTYDTRVYVYVDRSEPTFIWKVHKLFPNDIP--GRGPIIMIAVFTLGAVALLLLVLLRKYRKYDELROK 466
porcine KFAHAFNLTTFEGHMGVPTLDDCGDINDTMTFLYTSVDTSKYVLLTYDTRVYVYVDRSEPTFIWKVHKLFPNDIP--GRGPIIMIAVFTLGTIVLILLIALLVLRKYRKYDELROK 466

kinase-like domain

01GC9 KWSHIEPHLIDPLDEKE---VSLKIDEDDKRSDTFFSHRGVYDKKPVVYKELKHPDEDTEEQKIELNLLRIDYNYLTKFYGTIVKFEYGVGFELCQRGSLRYLLNDRISYPDETMD 577
01GC6 RWSHINPDLISLLENNEHNIIVSLKIEBERK--MCQIRRALYDKKIVLIRKLLKSDGFMKQAEIELNALLHIDYSLTKFYGTIVKFEYGVGFELCQRGSLRYLLNDRISYPDETMD 580
eel QWSHIPDRITFVDDKDFSLVSLKIDEDQKSDIRIRRGRYDKPIILASLKNTEGYFSEKRIELNLLRIDYNYLTKFYGTIVKFEYGVGFELCQRGSLRYLLNDRISYPDETMD 434
human KWSHIPPENIFPLETNETNHVSLKIDDDKRRDTIQRLRQCKYDKKRVILIRLKHNDGNFTEKQKIELNKLQIDYNYLTKFYGTIVKFDLMTIFGVIYECERGSLEVLNDTISYPDGTMD 586
porcine KWSHIPPENIFPLESNETNHVSLKIDDDRRRDTIQRLRQCKYDKKRVILIRLKHNDGNFTEKQKIELNKLQIDYNYLTKFYGTIVKFDLMSIFGVIYECERGSLEVLNDTISYPDGTMD 586

01GC9 MEFKISVMYDIAGKMSXLHNSIPVHGRKLSKNCVENDNRMVVKITDFGCHTILPKAKDLWTAPEHLRKDGVSQKGDVYSVAIIAHEIVTRXPPFYTCVSDSAEKMYRVQYPRNNFFRP 697
01GC6 WFKISVMYDIAGKMSYHASDIQVHGRKLSKNCVENDNRMVVKITDFGCAFLSREHDLWTAPEHLRKEGTSQKGDVYSFAICQIIVLRRSTFYTEASIKRKSRLVST---SYFRP 696
eel LEFKISVMHDIAGKMSYLHNSIAVHGRKLSKNCVDSRMVVKITDFGCSNLLRPSRDLWTAPEHLRNPQTSQKGDVYSFGIISQILLKCTFYTAACSDRAEKTYRVQPDSCSFFRP 554
human WFKISVLYDIAGKMSYLHSSKTEVHGRKLSKNCVDSRMVVKITDFGCSNLLAPKDLWTAPEHLRRASVSQKGDVYSYGIQAQIILRRPFTYTLSCRDQKEKIFRVNSNGMKVPRP 706
porcine WFKISVLYDIAGKMSYLHSSKTEVHGRKLSKNCVDSRMVVKITDFGCSNLLAPKDLWTAPEHLRRASVSQKGDVYSYGIQAQIILRRPFTYTLSCRDQKEKIFRVNSNGMKVPRP 706

catalytic domain

01GC9 ELNPEGASDRETEVYMLIKNCWDEDPERRPDPFKIELTLGKIFSNLHNQATETYMNDLIRLQMSRTLENLVEERTALYKAERDRADHLNFMLLPGPVVRSKTEGRVEPELFEVETIY 817
01GC6 DLNLETAESEKAEVYMLIKSCWEEDPEKRPDPFKVENLLGKISKIHNDQNSYMDMIRRLQMSKNLEHLVEERTALYKAERDRADHLNFMLLPRPVVSKESGAVEPELVEVETIY 816
eel DLNLETAGERERELCGLIKNCWDEDPKRPDPFKIETSLVLISS-LHSQNSYMDMIRRLQMSKNLEHLVEERTALYKAERDRADHLNFMLLPGPVVQSLKERGVEPELFEVETIY 673
human DLPLETAEKLELVLLVKNWDEDPKRPDPFKIETTLAKIFGLFHDQKNSYMDTILIRLQYSRNLEHLVEERTALYKAERDRADHLNFMLLPRVVKSLKEKGFVEPELFEVETIY 826
porcine DLPLETAEKLELVLLVKNWDEDPKRPDPFKIENTLAKIFGLFHDQKNSYMDTILIRLQYSRNLEHLVEERTALYKAERDRADHLNFMLLPRVVKSLKEKGFVEPELFEVETIY 826

01GC9 FSDIVGFTTLCHYSTPMEVVDMLNIIYKNFDSILDHHDVYKVTETIGDAYMVASGLPNRNGNRHDAVIDIARMALDILSFGVTFELQHLPLGIPIWIRIGVHSGPCAAGVGNKMPRYCLFGDT 937
01GC6 FSDIVGFTTLCHYSTPMEVVDMLNDIYKGFDSIVDHDVYKVTETIGDAYMVASGLPNRNGNRHDAVIDIARMALDILSFGVTFELQHLPLGIPIWIRIGVHSGPCAAGVGNKMPRYCLFGDT 936
eel FSDIVGFTTLCHYSTPMEVVDMLNEIYKNFDSILDHHDVYKVTETIGDAYMVASGLPNRNGNRHDAVIDIARMALDILSFGVTFELQHLPLGIPIWIRIGVHSGPCAAGVGNKMPRYCLFGDT 793
human FSDIVGFTTLCHYSTPMEVVDMLNDIYKSFHIVDHDVYKVTETIGDAYMVASGLPKRNGNRHDAIDIAKMALEDLSFGVTFEHLPLGIPIWIRIGVHSGPCAAGVGNKMPRYCLFGDT 946
porcine FSDIVGFTTLCHYSTPMEVVDMLNDIYKSFHILDHDVYKVTETIGDAYMVASGLPKRNGNRHDAIDIAKMALEDLSFGVTFEHLPLGIPIWIRIGVHSGPCAAGVGNKMPRYCLFGDT 946

01GC9 VNTASRMESTGLPLRIHVSQSTIKILQRTPCKEFEFQRGETYLGKKGEMTYLWTVGTVGNLNPPTTENFQRLQQLADMIISLKEKREGGKETIEKRKTLSTRINKDRNNSFQKE 1057
01GC6 VNTASRMESTGHPILRIHVSEPTIQLQRTNCKFEFEMRGETYLGKKGEMTYLWTVGTVGNLNPPTTENFQRLQQLAHMLIACLRESRGSRVRRKQHQDQKNDDEDESVESES 1056
eel VNTASRMESTGLPLRIHVSQPTISILQRTDCQVFFERRGETYLGKKGEMTYLWTVGTVGNLNPPTTENFQRLQQLAHMIESCLEKRLSGGRRKQKTLSTRQRREKEDG-QGD 912
human VNTASRMESTGLPLRIHVSQSTIAILKRTCEQFLYEVGRGETYLGKKGEMTYLWTVGTVGNLNPPTTENQRLQAEFSDMIANSLQKRAAGIRISQKPRVAS-----YKK 1055
porcine VNTASRMESTGLPLRIHVSQSTIAILKRTCEQFLYEVGRGETYLGKKGEMTYLWTVGTVGNLNPPTTENQRLQAEFSDMIASSLQKRAAGIRISQKPRVAS-----YKK 1055

PDZ domain

01GC9 SPPEYFHLAVTENP-STYL 1075
01GC6 SQPEYLHLAVTNDLSTFL 1075
eel QPAYSALLP---- 922
human GTLEYLQINTTDEK-STYF 1073
porcine GTLEYLQINTTDEK-STHF 1073

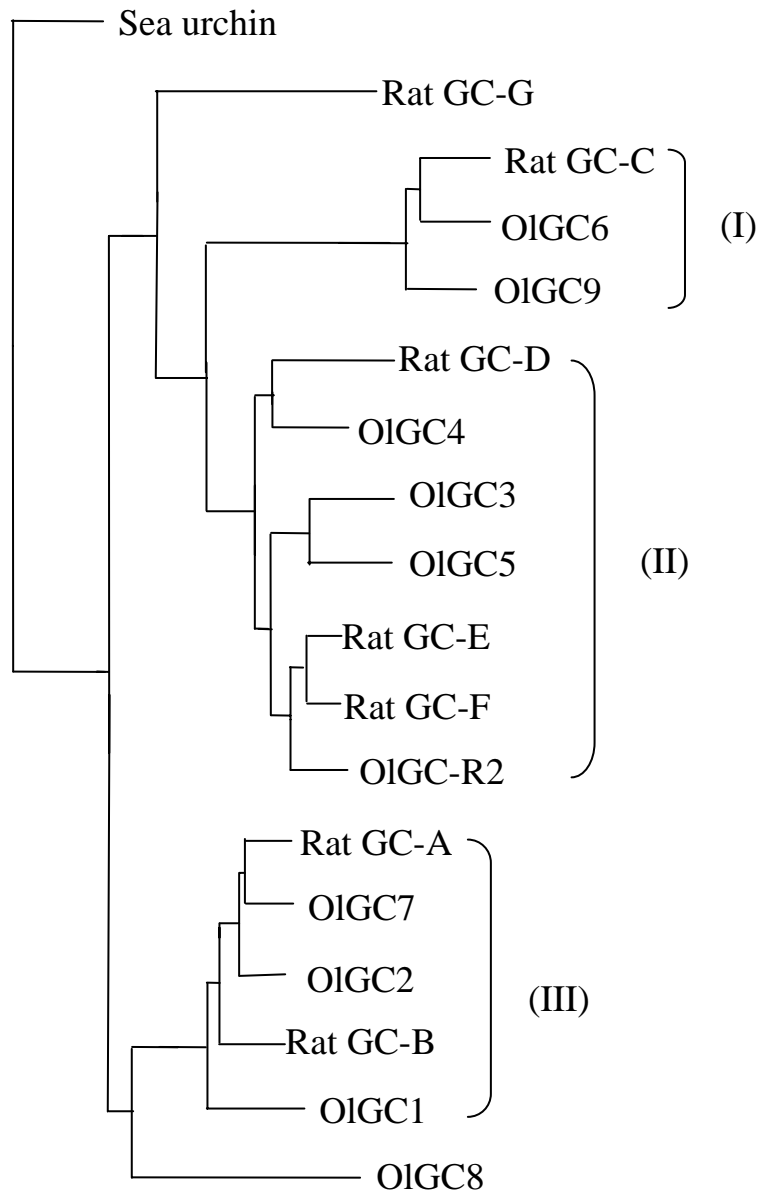

spleen *testis* *kidney* *ovary* *gill* *liver* *eye* *brain* *intestine*

OlGC9
25 cycles



OlGC9
28 cycles

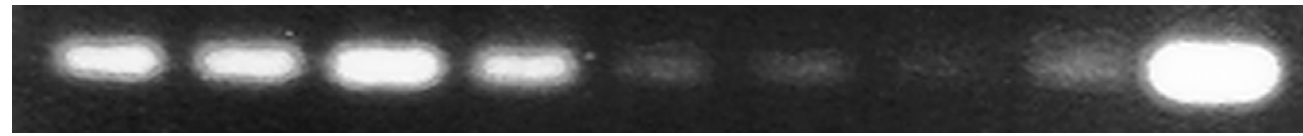

OlCA1
25 cycles



(A)

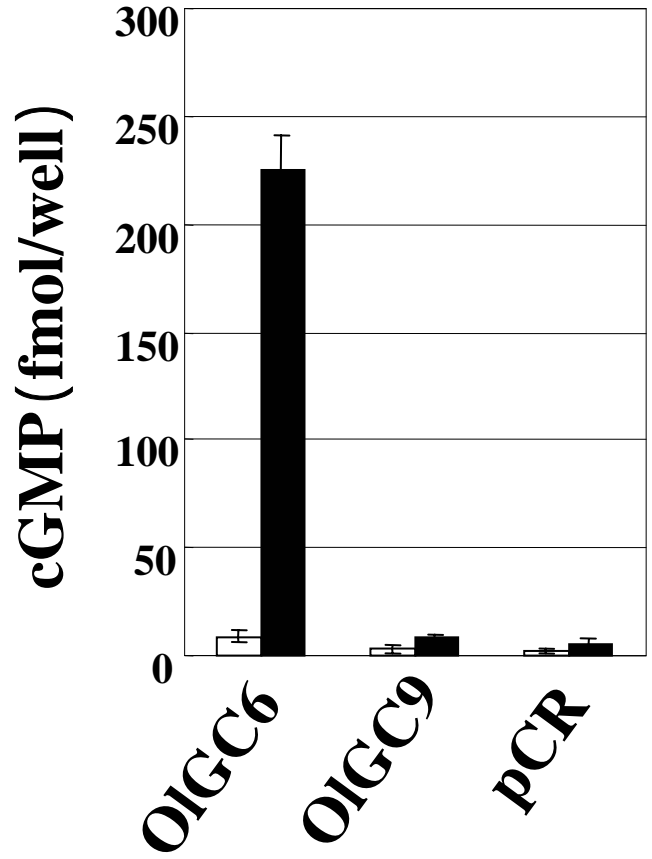

(B)

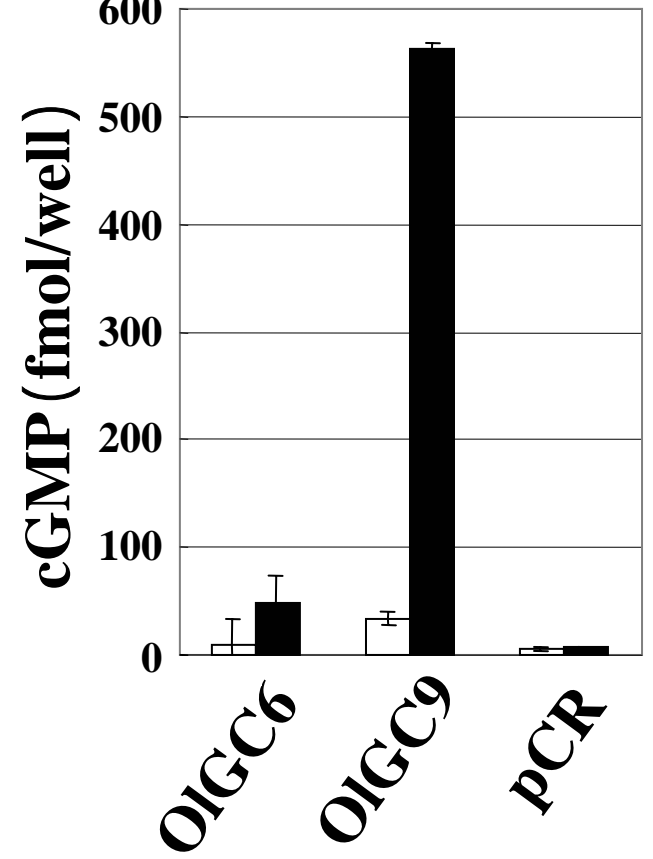

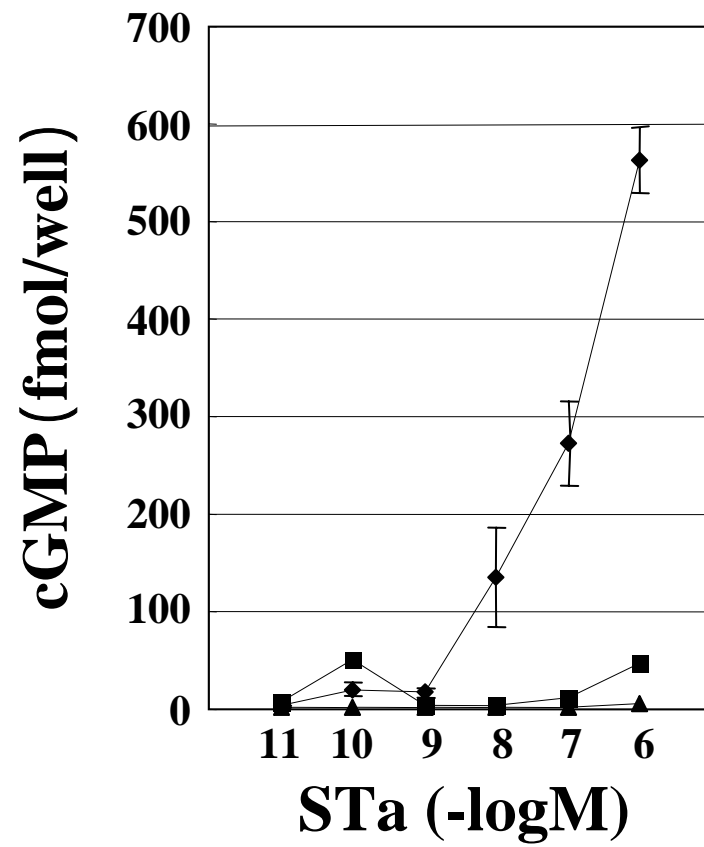

(A)

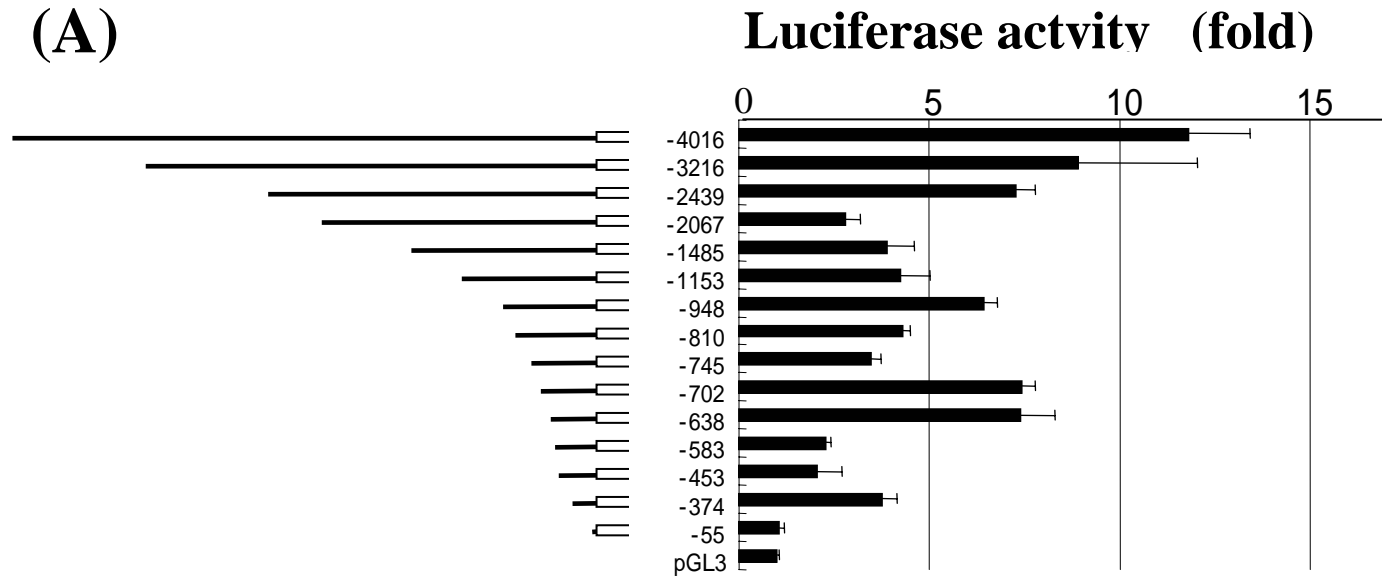

(B)

