



Title	Snow Crystals of Unusual Type Observed at the Summit of Mt. Teine
Author(s)	YAMAMI, Nobuyuki; MAGONO, Choji
Citation	Journal of the Faculty of Science, Hokkaido University. Series 7, Geophysics, 5(2), 39-45
Issue Date	1978-03-28
Doc URL	<a href="http://hdl.handle.net/2115/8696">http://hdl.handle.net/2115/8696</a>
Type	bulletin (article)
File Information	5(2)_p39-45.pdf



[Instructions for use](#)

## **Snow Crystals of Unusual Type Observed at the Summit of Mt. Teine**

Nobuyuki YAMAMI and Choji MAGONO

(Received Dec. 28, 1977)

### **Abstract**

Snow crystals of unusual type were observed under a polarization microscope at the summit of Mt. Teine. A snow crystal with an inside plate was observed when the summit was covered by supercooled clouds of  $-8^{\circ}\text{C}$ .

A trigonal column, a V-shaped crystal and several kinds of scissors type crystals were observed together with snow crystals of column or side plane type. Therefore, it was considered that they were formed at temperature ranges colder than  $-20^{\circ}\text{C}$ .

### **1. Introduction**

The observation of snow crystals was carried out at the top of Mt. Teine (1,024 m above sea level) over period ranging from Jan. 15 to 30, 1974. Snow crystals were sampled on slide glasses coated with silicon oil and were examined under a polarization microscope. During the period, several kinds of unusual snow crystals were observed. This paper will describe the shape of the unusual crystals.

### **2. Results and Discussion**

Yamashita<sup>1)</sup> experimentally produced a snow crystal of trigonal column type in a temperature range from  $-4.0^{\circ}\text{C}$  to  $-6.7^{\circ}\text{C}$  by seeding under adiabatic cooling. However, natural snow crystals of this type have not been reported, hitherto although frequently trigonal plate type have been published in books by Bentley and Humphreys<sup>2)</sup>, Nakaya<sup>3)</sup>, and Klinov<sup>4)</sup>.

The snow crystal of trigonal hollow column type in Photo. 1, was sampled in a snowfall. The environmental temperature on the day of sampling was  $-11^{\circ}\text{C}$ . It may be seen that a dendritic branch extends from a corner of the trigonal hollow column. It is therefore considered that the crystal fell through the growth range of dendrites after the formation of the column portion. Snow crystals of usual hollow columns and radiating assemblage of dendrites

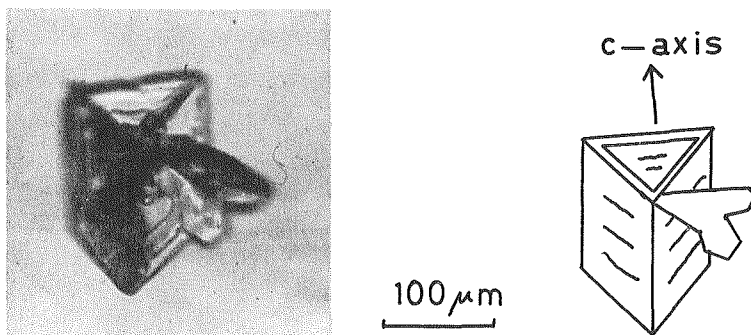

Photo. 1 Trigonal hollow column crystal.

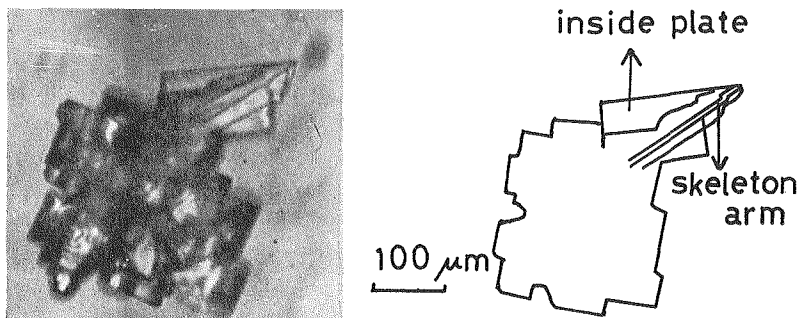

Photo. 2 Snow crystal with an inside plate.

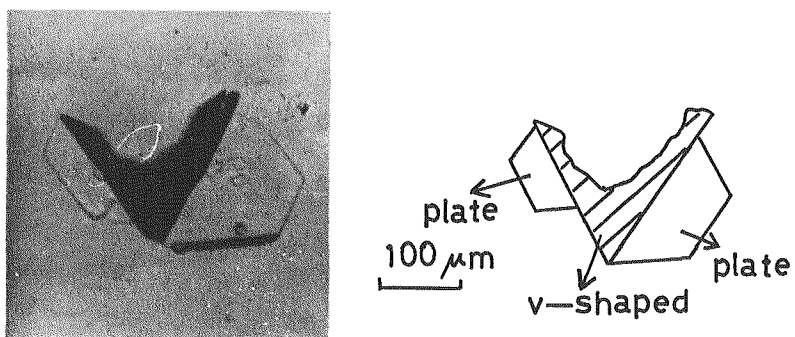

Photo. 3 V-shaped crystal.

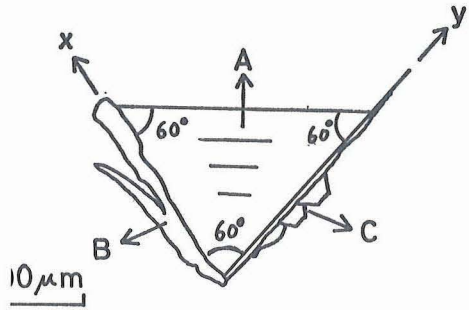
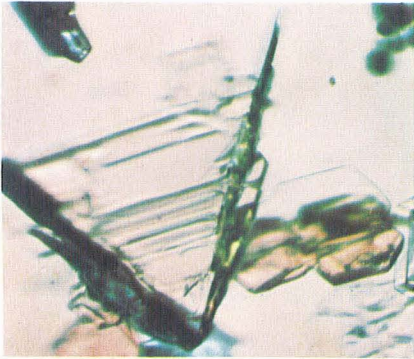

Photo. 4 Snow crystal of different type with crossed plates.

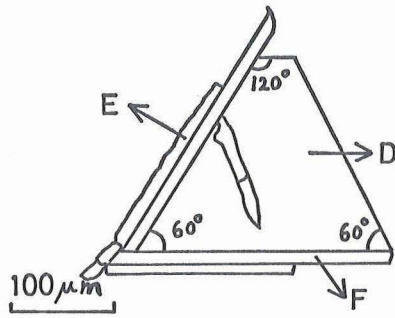
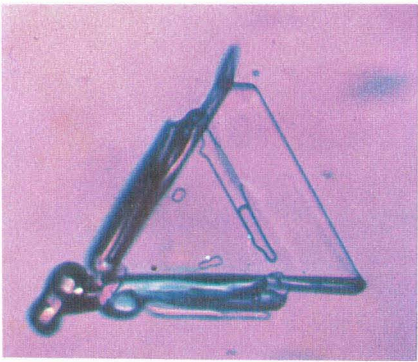

Photo. 5 Combination of two columns and a plate.

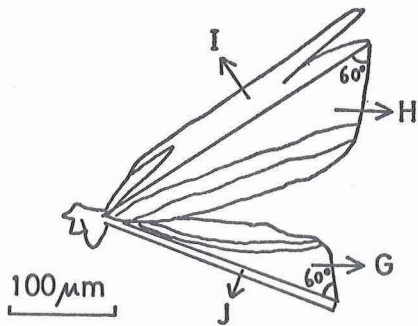
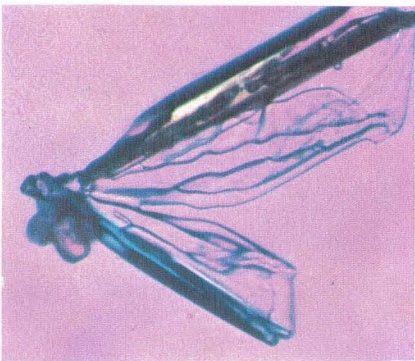

Photo. 6 Combination of a bullet, one column and plates.

were also observed when the trigonal hollow column was sampled. Therefore, the growth condition of the trigonal hollow column may be in a colder range than  $-20^{\circ}\text{C}^5$ ).

The authors<sup>6)</sup> previously described the morphology of snow crystals extending in the direction of the *b*-axis. The present trigonal hollow column is a typical example of such a *b*-axis type of crystals.

In Photo. 2, it may be seen that a plane extends from an assemblage of columns. The plane may be one of the so-called inside plates which can be artificially produced in temperature ranges from  $-4^{\circ}\text{C}$  to  $-11^{\circ}\text{C}$ , and from  $-22.8^{\circ}\text{C}$  to  $-26.1^{\circ}\text{C}$  as reported by Yamashita<sup>1)</sup>, because the crystal has a skeleton arm and rectangular steps. This snow crystal was observed when the observation site was covered by clouds with a temperature of  $-8^{\circ}\text{C}$ .

The snow crystal in Photo. 3, probably belongs to V-shaped crystal type<sup>1)</sup>, since the dark portion was identified as a single crystal under a polarization microscope and plates attached to the outer side, show partial hexagonal basal planes. This snow crystal was sampled when the temperature was  $-11^{\circ}\text{C}$  during a snowfall. Together with this snow crystal, usual side planes and radiating assemblage of plates were also sampled. Iwai<sup>7)</sup> has already sampled such a snow crystal which was considered to be a V-shaped crystal which however was not confirmed by him.

Scissor-shaped snow crystals were observed. The Scissor portions were polycrystals as illustrated in Photos. 4, 5, and 6. It may be seen that two stems contain a plane of  $60^{\circ}$ , however their shapes are different from the V-shaped crystals reported by Yamashita<sup>1)</sup>.

The snow crystal in Photo. 4, consists of three portions, (a plate indicated by *A* and two cross sections of Plates *B* and *C*). The plane *A* has no colour (the same as back ground) and has fine structure characteristic in the basal plane. Therefore, it is considered that the plane is a basal plane. In a consideration of the pattern of the structure of the plane, the directions of *a*-axes of the plane are in parallel to *x* and *y* respectively. The blue portions indicated by *B* is considered to be a cross section of the crossed plates. The yellow portions indicated by *C* is also considered to be a cross section of other crossed plates. Two minute plates (fraction of hexagon) are seen near the center of the cross section. It may be seen that the *a*-axes of the minute plates are common to that of the basal plane *A*. At the right side of the snow crystal, a typical crossed plate is seen.

The shape of a snow crystal in Photo. 5 resembles that of the snow

crystal in Photo. 4, but the portion of scissors are different. The plane *D* contained between *E* and *F* is considered to be a basal plane because of the same reason as described in Photo. 4. However, the portions of *E* and *F* are not cross sections of plates taking their shape and thickness into account but rather appear to be thin columns. However in this case, if the plane *D* is a basal plane, it is difficult to understand the combination of the basal plane with columnar crystals.

The planes *G* and *H* of the snow crystal in Photo. 6, are also considered to be basal planes for the same reason described above ( $60^\circ$  angle). The portion *I* has an appearance of a hollow bullet and the portion *J* appears to be a thin column. Therefore, this may have resulted because basal planes *G* and *H* are attached to the bullet and the column. The curved line structure is seen both in basal planes, *G* and *H*. Such curved structures are seen in the prism plane<sup>8)</sup>. In this case, the prism planes extend vertically from columnar crystals<sup>8),9),10)</sup>. However, in the present case, the angle between the bullet and the plane *H* is  $60^\circ$ , and the angle between the column and the plane *G* is also  $60^\circ$ . Therefore, the planes *G* and *H* may not be considered as prism planes.

Snow crystals of unusual types observed at the top of Mt. Teine are summarized in Table 1, together with snow crystals of usual types at the same observation time. Air temperatures under which such snow crystals were observed, are also shown.

The snow crystals in Photos. 4, 5, and 6, were observed together with snow crystals of side plane type. Therefore, it is considered that they were formed at a temperature range colder than  $-20^\circ\text{C}^{11)}$ . According to Magono

Table 1. Uncommon snow crystals observed and temperature at the top of Mt. Teine. The signs of usual snow crystals are quoted from meteorological classification of natural snow crystals by Magono and Lee<sup>5)</sup>.

Photo. No.	Condition	Temperature	Another snow crystals
1	snowfall	$-11^\circ\text{C}$	C1f. P7b
2	cloud	$-8^\circ\text{C}$	C1f. C1h
3	snowfall	$-11^\circ\text{C}$	S1. P7b
4	snowfall	$-12^\circ\text{C}$	S1. P7a
5	snowfall	$-13^\circ\text{C}$	S1. P7b. C2b
6	snowfall	$-13^\circ\text{C}$	S1. C2b

C1f: Hollow column, C1h: Thick plate of skeleton form, C2b: Combination of columns, P7a: Radiating assemblage of plates, P7b: Radiating assemblage of dendrites, S1: Side planes

and Sasaki<sup>10)</sup>, there are two types of snow crystals belonging to the side plane type. One is the crossed plate type, another is the extended side planes (prism planes) of a column. The C-portion in the snow crystal in Photo. 4, belongs to the crossed plate. However, it was considered in the present observation that the snow crystals in Photos. 5, and 6 cannot be included in the extended side plane type described above, because the plate portion containing the two columns, are not prism planes but are rather the basal plane, although, it is difficult to comprehend the attachment between the prism and basal planes.

### 3. Conclusion

The presence of trigonal columns was confirmed in snow crystals in the natural atmosphere. The temperature condition of the trigonal column was considered to be in a colder range than  $-20^{\circ}\text{C}$ . This temperature is much colder than that in which Yamashita<sup>1)</sup> artificially produced. The snow crystal with the inside plate and the V-shaped crystal which Yamashita<sup>1)</sup> artificially produced, were also observed in natural snow crystals. Snow crystals of scissor type were found. They are a combination of columnar crystals and basal planes.

*Acknowledgements:* The authors wish to express their thanks to the Cloud Physics Group of Hokkaido University for their valuable discussions and encouragements.

### References

- 1) YAMASHITA, A.: Study of ice crystals by using of the large cloud chamber. Kishō Kenkyū Note. J. Met. Soc. Japan, 123, (1974) 47-94. (In Japanese)
- 2) BENTLEY, W.A. and W.J. HUMPHREYS: Snow crystals. McGraw-Hill Book CO. (1931) 226pp.
- 3) NAKAYA, U.: Snow crystals. Harvard Univ. Press, (1954) 510pp.
- 4) KLINOV, F. Ya.: Voda v atmosfere pri nizki temperatura. Akad. Nauk, SSSR, (1961) 170pp.
- 5) MAGONO, C. and C.W. LEE: Meteorological classification of natural snow crystals. J. Fac. Sci., Hokkaido Univ., Ser. VII, 2, (1966) 321-335.
- 6) YAMAMI, N. and C. MAGONO: Morphological study on snow crystals abnormally extended to the b-axis. (to be published)
- 7) IWAI, K.: Uncommon and peculiar shapes of snow crystals observed at Shiga Heights, Nagano Prefecture. Shiga Shizen Kyoikushisetu Kenkyū Hōkoku, No. 11, (1972) 81-91. (In Japanese)
- 8) KIKUCHI, K. and A.W. HOGAN: Snow crystal observations in summer season at

- Amundsen-Scott South Pole Station, Antarctica. *J. Fac. Sci., Hokkaido Univ., Ser. VII*, **5**, (1976) 1-20.
- 9) KIKUCHI, K.: Peculiar shapes of solid precipitation observed at Syowa Station, Antarctica. *J. Met. Soc. Japan*, **48**, (1970) 243-249.
  - 10) MAGONO, C. and H. SASAKI: On the optical axis of snow crystals of the side plane types. *J. Fac. Sci., Hokkaido Univ., Ser. VII*, **3**, (1970) 267-275.
  - 11) MAGONO, C., K. KIKUCHI, and N. Yamami: On the meteorological conditions for the growth of snow crystals in colder temperature regions, as revealed by radiosonde data in the Antarctica. *J. Met. Soc. Japan*, **49**, (1971) 179-183.