



Title	Unknown and Peculiar Shapes of Snow Crystals Observed at Syowa Station, Antarctica
Author(s)	KIKUCHI, Katsuhiro
Citation	Journal of the Faculty of Science, Hokkaido University. Series 7, Geophysics, 3(3), 99-116
Issue Date	1970-03-18
Doc URL	<a href="http://hdl.handle.net/2115/8681">http://hdl.handle.net/2115/8681</a>
Type	bulletin (article)
File Information	3(3)_p99-116.pdf



[Instructions for use](#)

## Unknown and Peculiar Shapes of Snow Crystals Observed at Syowa Station, Antarctica\*

Katsuhiko KIKUCHI

(Received Nov. 1, 1969)

### Abstract

A series of observations on the shapes of snow crystals by means of microscopic photography, replica solution and the snow crystal sonde method were carried out at Syowa Station, Antarctica from the beginning of February 1968 to the end of January 1969.

As a result till now, unknown and peculiar shapes of snow crystals were discovered. It was considered that the majority of the peculiar shapes has some connection with the bullet and the side plane shape snow crystals known hitherto. And it was very interesting that the analysis of the time variation of shapes of snow crystals in a snowfall on September 26th, 1968 showed a number of peculiar shapes of snow crystals mixed with columnar shape crystals before and after the cold front passed. From the analysis of the growth regions of peculiar shapes of snow crystals expected from the sounding curves of temperatures and of relative humidities, it seems worthy of attention that the minimum temperatures in the cloud layers in which the peculiar crystals grew were higher than  $-35^{\circ}\text{C}$  in almost all cases of the crystals.

### 1. Introduction

New research objectives in the field of the meteorology were adopted by the 9th Japanese Antarctic Research Expedition. These were observation on Cloud Physics and Atmospheric Electricity. The following related themes were selected by the author based on necessity, possibility and interest of the subject matter at Syowa Station ( $69^{\circ}00'S$ ,  $39^{\circ}35'E$ ), Antarctica; thus observations of ice nuclei, condensation nuclei, sea-salt nuclei, surface electric field strength, the shape of snow crystals, the electric charges on falling and blowing snow, the observation of clouds, etc were made<sup>1)</sup>. In almost all cases these observations were carried out at Syowa Station from the beginning of Feb. 1968 to the end of Jan. 1969. Especially, the author was interested in the observation of the shapes of snow crystals, because it is on record that

---

\* This work was made when the author was a member of Meteorological Research Section, Wintering Party, the 9th Japanese Antarctic Research Expedition (1968-1969).

interesting changes in snow crystal habits occur around  $-40^{\circ}\text{C}$  or under in air temperature<sup>2),3),4)</sup>. For instance, in Shimizu's case<sup>4)</sup>, a "Long Prism" snow crystal was discovered at Byrd Station ( $80^{\circ}\text{S}$ ,  $120^{\circ}\text{W}$ ), Antarctica in a temperature range from  $-30^{\circ}\text{C}$  to  $-45^{\circ}\text{C}$ . At Syowa Station, it was recorded that the minimum air temperature was  $-42.7^{\circ}\text{C}$  in 1961. Thus, it was expected that "Long Prism" snow crystals would be observed with respect to temperature alone.

## 2. Observational techniques

In the observations on the shapes of snow crystals, microscopic photography, replica solution (1.5%) and the snow crystal sonde<sup>5)</sup> methods were used. Microscopic photography observations and replica solution studies were carried out in almost all types of snowfall, namely, quiet falling snow, drifting snow and blowing snow. Usually, microscopic photographs were taken at time intervals of 15 min to 30 min during each snowfall. But under excellent conditions for observation, for instance when beautiful shapes, perfect external shapes, peculiar and interesting shapes were seen, the photographs were taken at every 5 or 10 minute intervals. On the other hand, the replica solution method was carried out at time intervals of 15 min to 30 min. The snow crystal sonde method was carried out by the use of a captive balloon (American made small kytoon, volume  $\approx 3\text{ m}^3$ ) which is different from general usage. The length of the captive rope was 500 m.

## 3. Results

Throughout the observational period, data from 2400 pictures and 600 slide glass replica plates and 3 snow crystal sondes were obtained. As a result of an analysis of the microscopic photographs, hitherto unknown and peculiar shapes of snow crystals were observed. All pictures of snow crystals shown in this paper were taken by microscopic photography and not by the replica solution method.

### 3.1 *General shapes of snow crystals*

Almost all types of shapes of snow crystals by Nakaya's classification<sup>6)</sup> with the exception of needle shape were observed. And general shapes of snow crystals except minute hexagonal plate were found relatively early in winter under natural conditions. Some general shapes of snow crystals are shown in Photos. 1-6. Especially, most frequently observed in falling

snow were the shapes of "bullet", "combination of bullets" and "column" at Syowa Station.

### **3.2** *Peculiar shapes of snow crystals*

Sometimes through the observational period, unknown and peculiar shapes of snow crystals were observed when the bullets, combination of bullets and columns were falling. These were relatively large and were recognized relatively easily by the naked eye on slide glasses before taking microscopic photographs.

Each crystal will be explained below.

#### **3.2.1** *Sintered frozen cloud particles*

Precipitations of "Sintered frozen cloud particles" were observed four times on the following dates, May 13th, June 8th, July 13th and September 26th. Photographs of the former two dates are shown in Photos. 7 and 8, respectively.

Splendid examples of the sintered frozen cloud particles are shown in Photo. 7. The condition of snowfall which began at 1220 LMT on June 8th, 1968 was different somehow based on 'trained intuition'. And this phenomenon was continually observed for about ten hours under a slightly strong wind condition. It was very interesting that the number of single frozen particles was much less than the two or more sintered frozen particles during this snowfall. According to Kumai's observation<sup>7)</sup> of ice fogs in Alaska, it was reported that 74% of the particles collected consisted of aggregates of two or more spherical ice crystals. On the other hand, the crystals with close twin columns found by Kumai were not seen in this snowfall. But, the radii of the ice neck of each sintered particles were much larger than those of the experiments by Kingery<sup>8)</sup>, Kuroiwa<sup>9)</sup> and Hobbs<sup>10)</sup>. Concerning this problem, a report will be made in the near future. A number of small corrugations were observed on the surfaces of a few relatively larger particles in a "Sintered frozen cloud particle" consisting of aggregates of additional frozen cloud particles. No clouds were observed at the sounding time on that day. If the sounding data of the following day (Fig. 1) were substituted in spite of the difference in shape of the frozen particles, the temperatures of the top of cloud and the surface would be  $-27.4^{\circ}\text{C}$  and  $-21.1^{\circ}\text{C}$ , respectively.

In the case of Photo. 8, diameters of each frozen particles were larger than those of Photo. 7. And the number of two or more sintered frozen

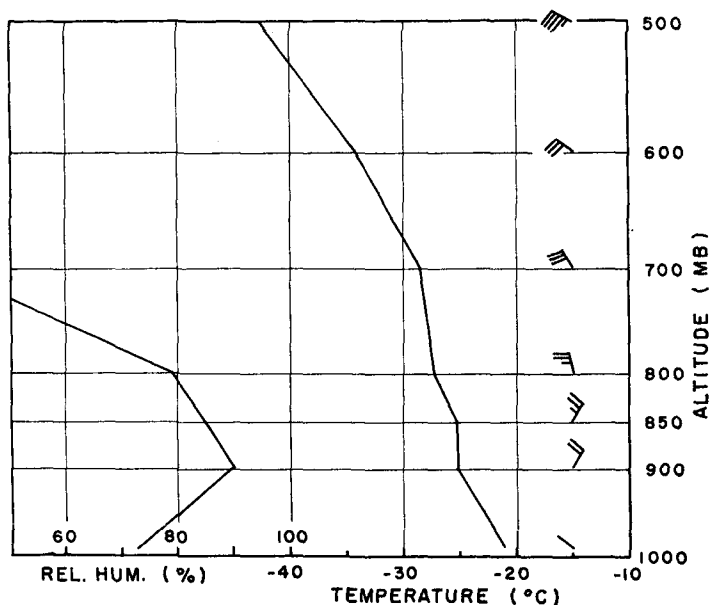

Fig. 1. The condition of the upper atmosphere at 00Z June 9th, 1968.

particles was much less than that of single particle. Further the characteristic feature of these particles was an appearance of growth of plane crystals. And some of the particles took the form of spikes<sup>11)</sup> or spicules<sup>12), 13)</sup> (black arrow in the photograph).

And the other two cases were observed with irregular ice particles during blizzards.

### 3.2.2 Double plates

"Double plate" crystals were observed on March 8th (Photo. 9) and May 7th (Photo. 10). This shape of crystal is not so uncommon, because it can be found in Nakaya's book<sup>6)</sup>, but not in Клинов's book<sup>3)</sup>. Pondering the crystal growth, it may be considered that double plate crystals may be a kind of a "Tsuzumi" (No-play hand drum) type crystal, therefore circle-like shapes (Photo. 9) and a hexagonal like shapes (Photo. 10) which are recognized around the center position may be columns even though they are very small in size. But the question as to why the external shapes of piled up parts which hold the center columns do not show the original shape of the crystals, remains, especially in the case of Photo. 9. According to the Nakaya's book<sup>6)</sup>, double

parts seem to be a mere surface structure, especially as shown in the shape of dendritic crystal in Plate 72 which is not a "Tsuzumi" type.

**3.2.3 Crossed plates**

Two kinds of "Crossed plates" are shown in Photos. 11 and 12. The same crystals are seen in Fig. 27, Nos. 52 or 68 and 61 in КЛИНОВ's book<sup>3)</sup>. These two cases were observed under a condition of clouds in which a relatively high grade of vapor supply was present.

**3.2.4 Simple tetragon**

"Simple tetragon" crystals were observed on August 11th and September 26th. These crystals are shown in Photos. 13 and 14. The peculiarities of the simple tetragon are the tetragon form of the external shape and the ridge along the diagonal line. The ridge is straight and the angle between the upper long side of the rectangular crystal and the ridge is approximately 20°. In the example of Photo. 13, the upper long side may be growing to form a poor scroll because the long side is rather thicker than other parts. It is not clear whether the simple tetragon is the result of disintegration during the

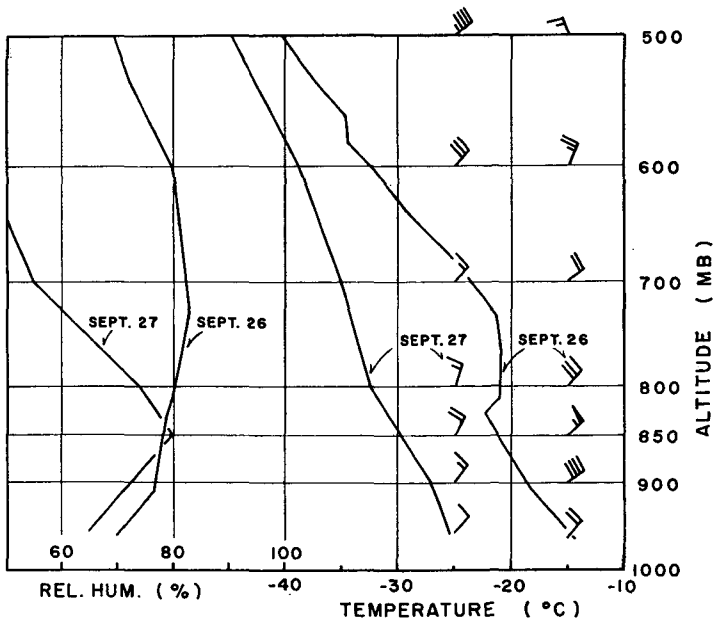

Fig. 2. The condition of the upper atmosphere at 00Z September 26th and 27th, 1968,

falling of some kind of crystals combinations or of the growth of the crystal itself. The ranges of air temperature and relative humidity of the above two days in which these crystals were observed coincided. Sounding curves on September 26th, 1968 are shown in Fig. 2 in which the estimated minimum temperature in this cloud was  $-34.5^{\circ}\text{C}$ .

### 3.2.5 *Tetragon with bullets*

“Tetragon with bullets” crystals were observed on three days, namely, July 29th and 30th, and September 26th. Photographs of this crystal are shown in Photos. 15 and 16. It seems that the tetragon grows from two bullets (clear in Photo. 15, unclear in Photo. 16) which are at right angles. And in almost all cases, a ridge from the point of the bullet, namely, the position of the nucleus, to the opposite point along a diagonal line is seen. Furthermore, although the angle between the direction of the growth of two triangular planes is divided into two by the ridge and the ridge has a different angle even in the same shape of crystal, the sum of the two angles at any point on the ridge is a right angle. Therefore, it is considered that this tetragon is not two planes divided into two by the ridge but a plane on which

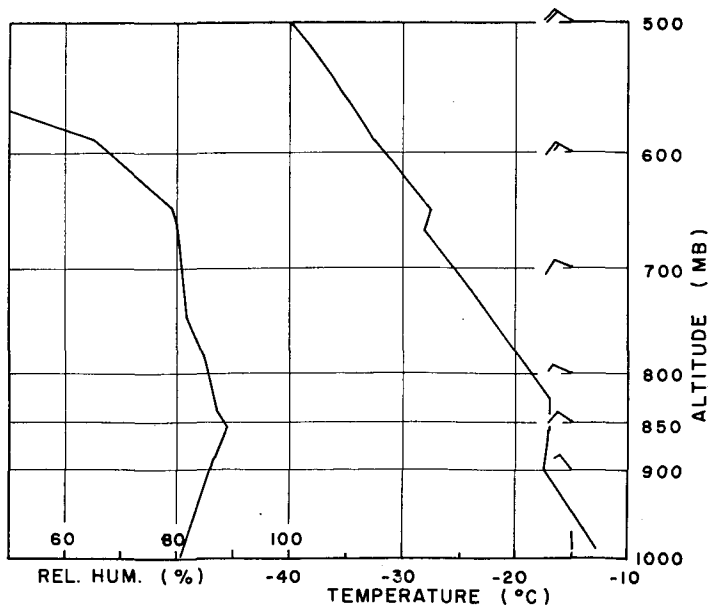

Fig. 3. The condition of the upper atmosphere at 00Z July 29th, 1968.

the ridge is included. Also it is different from "Simple tetragon" in that, it has bullets and a rather square form as compared with the rectangular ones. In this crystal, crystals which appear to be bullets may also be a variation of scrolls. Sounding curves on July 29th are shown in Fig. 3. From the figure, the top of the cloud was around 650 mb (3000 m) and the minimum temperature in this cloud was  $-28^{\circ}\text{C}$ . This was a very warm condition in the mid winter season in the Antarctica.

### **3.2.6** *Skeltonlike tetragon*

One kind of snow crystal in which the external shape was a tetragonal form but which was different from "Simple tetragon" and "Tetragon with bullets" was observed on September 26th (Photos. 17 and 18). The surface structure seems to have a skelton structure cut by a plane including the *c*-axis. Thus, it was named "Skeltonlike tetragon".

### **3.2.7** *Scroll crystal of bullet type*

The scroll crystal was classified by Magono and Lee<sup>14</sup>). But in their paper, the scroll is formed on the columnar crystal externally. "Scroll crystal of bullet type" was observed around noon on September 26 as shown in Photos. 19 and 20. Although the time variation of the shape in a snowfall on September 26th, 1968 will be described in the later section, a number of unknown and peculiar shapes of snow crystals were observed on that day.

### **3.2.8** *Bullet with a side plane*

A curious snow crystal was found on July 17th (Photo. 21). It was considered that this shape was a variation of the side plane. Thus, it was named "Bullet with a side plane". This shape was different from those observed hitherto in that they were characterized by a "Bullet *with* a side plane" and a "Combination of side planes, bullets and columns" as seen in Plate 19 of the paper of Magono and Lee<sup>14</sup>). Actually, in the crystals of this shape which were observed on July 30th, the shape of the side plane was in a rectangular form (Photo. 22). Although the external shape is the same, it may be advisable to separate these two crystals into different types because the ranges of temperatures and relative humidities of Photos. 21 and 22 are different from each other. That is to say, in the case of Photo. 21, the temperatures of the top of cloud and the ground surface and the relative humidities of the maximum in the cloud layer and the ground surface were  $-37.5^{\circ}\text{C}$  and  $-24^{\circ}\text{C}$ , 77% and 55%, respectively. On the other hand, in the



case of Photo. 22, the values were  $-20^{\circ}\text{C}$  and  $-13^{\circ}\text{C}$ , 100% and 78%, respectively. The angle between a bullet and the center axis of the crystal of Photo. 21 was approximately  $51^{\circ}$ .

### **3.2.9** *Combination of bullets and a rectangular side plane*

Other peculiar shaped snow crystals, namely "Combination of bullets and a rectangular side plane" was observed on July 18th (Photo. 23) and on September 26th (Photo. 24). But there is a little difference in shape of the rectangular forms from each other, especially the shape of the ridge along the diagonal line is different. Notwithstanding the shape of the rectangular side plane which in itself interesting and curious, a combination of bullets and a rectangular side plane was quite unexpected based on our present knowledge of crystal growth. Fig. 4 shows the sounding curves on July 18th. In this figure, the range of the cloud was clear and the minimum temperature in the cloud was  $-30.5^{\circ}\text{C}$ . It was a very warm condition in the mid winter season in the Antarctica.

### **3.2.10** *Assemblage of periodic scrolls with side planes*

Fifteen minutes after the above crystal was observed, a most spectacular crystal shape was discovered as shown in Photo. 25. Furthermore, the same shape of crystals were observed on July 29 (Photo. 26). They were in shape of a "Gohei". A "Gohei" is a Japanese word for the pendant paper strips hanging from a sacred rope at a Shinto shrine. Concerning the crystal of Photo. 25, the center nucleus should be in the part of the combination of bullets as seen in the lower part of the picture. The crystal was divided into four parts, namely, a combination of bullets, a pair of a bisymmetrical tetragons with a bullet which may be seen on the lower side, three pairs of a bilateral bullets and three periodic lozenge shape side planes from the lower to the upper part in the picture. Bullets of "a pair of a bisymmetrical tetragons with bullets" may be a kind of a scroll, if this is so, the planes of the bisymmetrical tetragon may be prism planes developed with the scrolls suggested above. Furthermore, each bilateral bullet may be likewise a kind of a scroll. If this is true, this crystal may be named "Assemblage of periodic scrolls with side planes". But since it is a very long complicated name, a "Gohei shaped crystal" may be a more suitable name. The angle between the center axis and the rows of bullets of the crystal of Photo. 25 is approximately  $49^{\circ}$ . And another example of the same kind of crystal showed the same

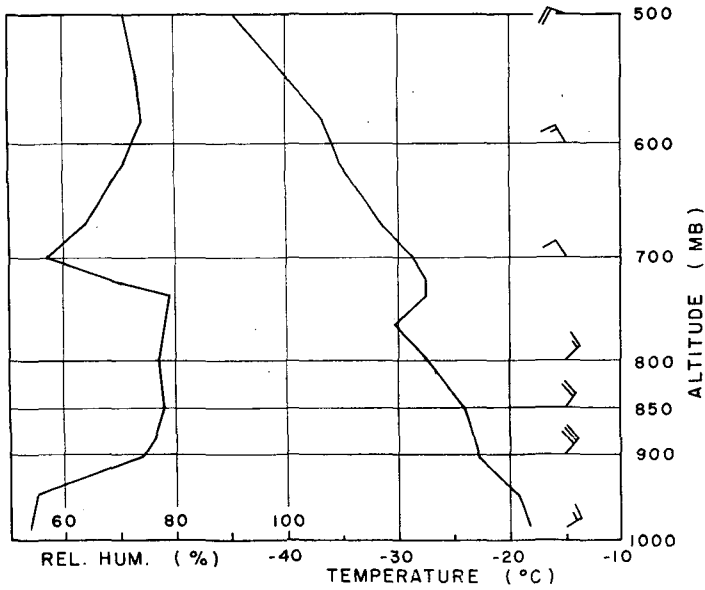

Fig. 4. The condition of the upper atmosphere at 00Z July 18th, 1968.

degree, while Photo. 26 and another had an angle of  $51^\circ$ . This value of degree coincides with the crystal of the "Bullet with a side plane" shown in Photo. 21. Therefore, as pointed out in 3.2.8, although the external shape of Photos. 21 and 22 is the same, it may be advisable to separate these crystals. And the crystal in Photo. 21 may be included in the group of Photos. 25 and 26. Sounding curves on July 18th and 29th are Figs. 4 and 3 described above, respectively. Each minimum temperatures in the clouds were  $-30.5^\circ\text{C}$  and  $-28^\circ\text{C}$ , respectively. It may be added here that these temperatures are not infrequently recorded in the clouds and on the ground surface in winter seasons in Hokkaido.

### 3.2.11 Periodic combination of bullets

The crystals as shown in Photos. 27 and 28 clearly resemble that in Photos. 25 and 26. But it has the following distinctions, namely, (i) the main part of these crystals are formed from a number of periodic bullets, furthermore, (ii) the points of each bullets are directed towards the center axis, in other words, they are growing face to face along the center axis, and (iii) the angles between the center axes and the rows of bullets of these crystals are almost

27°. Therefore, the angles of the opposite side are 153°. Another crystal of this shape has the same angle. The name of these crystals is "Periodic combination of bullets".

### **3.2.12** *Iciclelike crystal*

"Iciclelike crystal" (Photos. 29 and 30) was observed on July 29th and September 26th. This crystal is similar to "Assemblage of periodic scrolls with side planes" and "Periodic combination of bullets" in external shape. But the surface of this crystal closely resembles an icicle and has no clear crystal edges.

### **3.2.13** *Scalelike side planes*

"Scalelike side planes" were observed frequently at Syowa Station. And also this crystal has been frequently observed in Hokkaido<sup>6)</sup><sup>14)</sup>, Japan. But the crystals as shown in Photos. 31 and 32 were longer ones than in Hokkaido. According to Magono and Lee<sup>14)</sup>, the range of temperature of the crystal of side planes is between  $-20^{\circ}\text{C}$  and  $-25^{\circ}\text{C}$  with a relatively higher grade of vapor supply. However, the temperature range of the crystal at Syowa Station is expected to be warmer by  $5^{\circ}\text{C}$  or more of the mean value for the five days when this crystal was observed as compared with the previous range from the sounding curves.

### **3.2.14** *Scalelike side plane with scrolls*

The "Scalelike side plane with scrolls" was observed on June 11th (Photo. 33) and July 29th (Photo. 34). Scroll crystals were found developed at both ends of the crystal in Photo. 33. On the other hand, in the crystal of Photo. 34, the scrolls developed from around the center half. According to Magono and Lee<sup>14)</sup>, the range of temperature of the crystal of scroll is between  $-8^{\circ}$  and  $-10^{\circ}\text{C}$  with a relatively higher grade of vapor supply. In the case of Photo. 33, the temperatures of the top of the cloud and the surface by the sounding were  $-14.5^{\circ}\text{C}$  and  $-5.5^{\circ}\text{C}$ , respectively. Furthermore, the temperature of the cloud in which the highest humid layer (91% R.H.) was recorded was  $-9^{\circ}\text{C}$ . This degree of the temperature was in good agreement with that of the crystal of scroll reported by Magono and Lee. But, the temperature range of the crystal of the side plane could not be explained from the sounding curve. In the case of Photo. 34, however the temperature range of the side plane approximately coincided with the sounding, while that of the scroll could not be explained.

### **3.2.15** *Combination of bullets with a long bullet*

At Syowa Station, snowfalls with a combination of bullets were frequently seen during the winter season. But "Combination of bullets with a long bullet" as seen in Photos. 35 and 36 were seen for only two days, on May 16 and July 18th. On May 16th, crystals with a shape of "Long prism with pyramidal faces" was observed, too. This crystal will be described later. The crystal of "Combination of bullets with a long bullet" are seen in only one picture in Nakaya's book<sup>6)</sup> (Plate, 115) and ten pictures in КЛИНОВ's book<sup>3)</sup> (Figure, 17). In the case of Photo. 35, the temperatures of the top of cloud and the surface were  $-33^{\circ}\text{C}$  and  $-7^{\circ}\text{C}$ , respectively. And the relative humidity of the surface was 68%. In the case of Photo. 36, the temperature of the top of the cloud and the surface were  $-27.5^{\circ}\text{C}$  and  $-18^{\circ}\text{C}$ . And the relative humidity of the surface was 54%. On the other hand, in the КЛИНОВ's ten pictures, the ranges of temperatures and the relative humidities of the surface were from  $-55^{\circ}\text{C}$  to  $-42^{\circ}\text{C}$ , and from 75% to 79%, respectively. Thus, there was a very large difference between the author's case and the КЛИНОВ's case with respect to the temperatures and the relative humidities.

### **3.2.16** *Bony crystal*

"Bony crystals" have a different meaning and shape from the "Bony frames" in Nakaya's book<sup>6)</sup>. They were observed on September 14th. Photos. 37 and 38 show these crystals. These crystals were observed during falling of a "Combination of bullets".

### **3.2.17** *Long prism with pyramidal faces*

The shape of the snow crystal shown in Photo. 39 resembles Shimizu's "Long prism"<sup>4)</sup>, but it differs somewhat in that it has pyramidal faces at one end. According to Kobayashi's artificial snow making experiment<sup>15)</sup>, long prism crystal "capped" with pyramidal faces at the end developed in a temperature range of  $-50^{\circ}$  to  $-90^{\circ}\text{C}$ . The temperature of the top of the cloud estimated from the sounding curve was around  $-33^{\circ}\text{C}$ . The surface air temperature at the time was  $-7.3^{\circ}\text{C}$ . These values were higher than in Kobayashi's experiments. Furthermore, no temperature inversion as pointed out in Shimizu's work was found in the sounding curve. But with regards to the values of relative humidity at the cloud top level, the highest humidity in the cloud and on the surface were 80%, 85% and 68%, respectively.

Thus, it was surmized that the layer of this cloud had a relatively low supersaturation. This coincides with the findings of Shimizu and Kobayashi.

### **3.2.18** *Rimmed scroll*

A "Rimmed scroll" crystal (Photo. 40) was observed on September 26th. Magono and Lee<sup>14)</sup> did not introduce the "Rimmed scroll" in the classification of the "Rimmed columnar crystal". They classified the "Rimmed columnar crystal" in two kinds of "Rimmed sheath" and "Rimmed column". Thus, the writer is of the opinion that "Rimmed scroll" should be added to their classification. In the case of Photo. 40, a number of frozen cloud droplets had crystalized and their main axes were in parallel with the main crystal axis.

### **3.2.19** *Plate with spikes*

A crystal of "Plate with spikes" was observed on July 31st (Photo. 41). Three spikes are seen growing at the three corners of the plate. The focus in this picture is fixed not on the hexagonal plate but on the upper part of the spikes. In this case, the word "spike" is different from the mechanism of the spike in the case of Mason and Maybank<sup>11)</sup>. The angle between the plate and each spikes did not examined.

### **3.2.20** *Pentagon with bullets*

A "Pentagon with bullets" crystal as shown in Photo. 42 was observed on September 26th. It has a very interesting surface structure and external shape. But, it may be a variation of a "Tetragon with bullets" in Photos. 15 and 16 or a rectangular side plane in "Combination of bullets and a rectangular side plane" as seen in Photo. 23.

### **3.2.21** *Hexagonal barrel ?*

When the bullet shaped snow crystals and combination of bullets were falling, an amazing crystal as shown by the black arrow in Photo. 43 was found on the slide glass. The external shape of the crystal was similar to the "Thick plate". But, the author believed at that time with certainty that the crystal was not a "Thick plate" but a "Hexagonal barrel". And the other two pictures were taken under high magnification and by changing the focus as seen in Photos. 44 and 45. In Photo. 44, the focus was fixed on one side of the crystal and on the opposite side in Photo. 45. From these two pictures, the reader should be able to recognize the shape described above. If

this is true, although it is very difficult to explain the mechanism of the crystal growth, it may have a similar formation process to that of the skelton-like and the sheathlike crystal.

**4. Time variation of shapes of snow crystals in a snowfall on September 26th, 1968**

A snowfall began in the early morning on September 25th, 1968. The shapes of snow crystal by means of a microscopic photograph around 9 o'clock were almost all of an irregular form. And after 1700 hrs, the snowfall continued accompanied by a relatively strong wind sometimes exceeding 20 knots. The next morning, on September 26th, the wind velocity was around 30 knots, and the horizontal visibility decreased to 4 km. At around 1100 hrs, clear shapes of hollow columns and hollow bullets were observed. And from this time the observation of the shapes of snow crystals was continued to 2000 hrs. Fig. 5 shows the changes of the air ( $T_a$ ), the dew point ( $T_d$ ) temperatures, the wind direction and velocity (long barb indicates 10 knots and

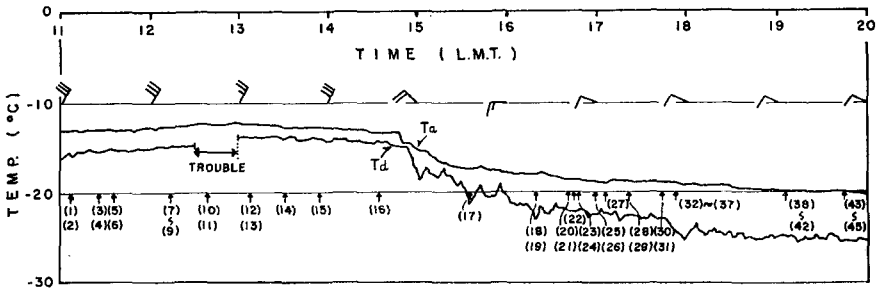

Fig. 5. Time variations of shapes of snow crystals and the weather conditions on September 26th, 1968.

the short barb 5 knots). The time scale of  $T_d$  is 5 minutes later than  $T_a$ . In this figure, the parenthesized numbers (1) to (45) with small arrows show the number of photographs of snow crystals which were taken at the time pointed out by the small arrows. For instance, numbers from (32) to (37) at 17:53 show six photographs of typical shapes of snow crystals in nineteen photographs taken at this time.

As described previously, the shapes of snow crystals at the beginning of the observation were hollow columns and hollow bullets as seen in photograph (1) and the skeltonlike tetragon of photograph (2) with irregular ice particles

was seen. The shapes of snow crystals up till around 12:30 were hollows, scroll and peculiar shapes, namely, iciclelike crystals (7), tetragon with bullets (8) and scroll crystals of bullet type. For about one hour from 12:38, sectors, plates and sintered frozen cloud particles were prevailing (photographs (10) to (14)) and the difference between  $T_a$  and  $T_d$  was becoming smaller than that of one hour before. Again, hollow columns and hollow bullets were prevailing for the next one hour and half. At 14:50, a cold front passed over Syowa Station. Thus the wind direction changed from northeast to westward and the velocity decreased. Both temperatures of air and dew point suddenly fell and the difference of both temperatures became larger and larger. The sounding curves of before and after the cold front passing is shown in Fig. 2. Immediately after the cold front passed, no sintered frozen cloud particles were observed. And hollow bullets and side planes type of snow crystals were mainly observed. In relation to the properties of the single bullet and combination of bullets, little difference was seen from the results of the writer's work<sup>16)</sup> in Hokkaido. Furthermore, various kinds of peculiar crystals were observed up till 2000 hrs. Especially, photographs 23, 24, 26, 29, 31, 33, 34, 36, 37, 40, 42, and 45 were very peculiar. Further, photographs 23, 24, 31, 34, 37, and 40 in the above description were not classified in Section 3.2.

It was very interesting that various kinds of peculiar snow crystals were observed before and after the cold front passage.

### 5. Growth ranges of peculiar shapes of snow crystals

As described previously, various kinds of peculiar shapes of snow crystals were observed. The following growth ranges of peculiar shapes of snow crystals were estimated from the sounding curves of temperatures and relative humidities for the first approximation. The growth ranges are collected on Fig. 6 for each crystals. In the figure, black dots (●) and white circles (○) connected with solid lines (—) show the estimated temperatures of the cloud tops and the surface air temperatures, respectively. And the cross marks (×) on the solid lines show the temperatures of the maximum relative humidity layers in the clouds. Thus, in some cases, the temperature of the cloud top coincides with that of the maximum relative humidity layer. On the other hand, black dots (●) and white circle (○) connected with dotted lines (⋯) show the maximum relative humidities in the clouds and the relative humidities of the surface, respectively. The reason why the surface

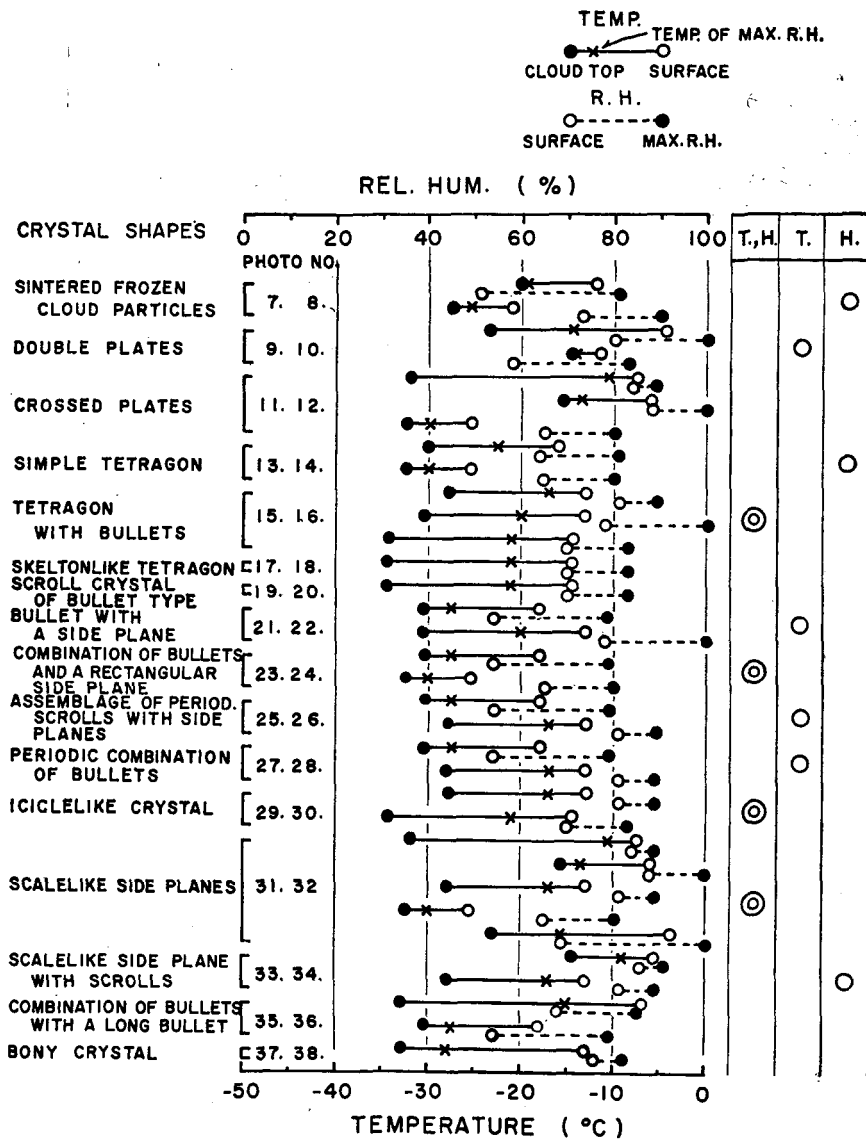

Fig. 6. Growth ranges of peculiar shapes of snow crystals.

values of both temperature and relative humidity were used instead of the values of the cloud bases are as follows: (1) in some cases, it was very difficult to clarify the cloud base with compared to the cloud top, and (2) for



comparing with КЛИНОВ's book<sup>3)</sup> in which he compared the shapes of snow crystals to the surface temperatures because of he had no sounding data.

It may be pointed out that in many cases at Syowa Station no typical temperature inversions on the surface were observed during the time when the snow crystals of peculiar shapes were falling.

Furthermore, concerning the case of September 26th, the snow crystals observed before 1500 hrs were fitted to the sounding data of 26th, and after 1500 hrs were fitted to that of the 27th, because a clear differences of both temperature and humidity were recognized before and after the cold front passed.

The result of the evaluation of the growth ranges is shown in the right hand side column in Fig. 6. The peculiar shapes in which the ranges of both temperature and humidity coincide with each other are "Tetragon with bullets", "Combination of bullets and a rectangular side plane", "Iciclelike crystal" and "Scalelike side planes" except in the case of September 26. They are shown by a double circle in (T., H.) in the right column. For instance, in the case of the "Tetragon with bullets", the expected mean growth ranges of temperature and relative humidity are from  $-13^{\circ}\text{C}$  to  $-30^{\circ}\text{C}$  and from 75% to 90% respectively. In relation to the temperature (T) alone, four groups of the crystals coincide. For instance, the growth ranges of temperature are from  $-15^{\circ}\text{C}$  to  $-27.5^{\circ}\text{C}$  in both cases of "Assemblage of periodic scroll with side plane" and "Periodic combination of bullets". On the other hand, with special regards to the relative humidity (H) alone, the ranges are from 70% to 80% in the case of "Simple tetragon" and from 85% to 90% in the case of "Scalelike side plane with scrolls". The growth ranges of the other groups except for those described above were scattered.

The most attention demanding and important phenomenon was that the minimum temperatures in the clouds in which the unknown and peculiar crystals grew, as estimated from the sounding curves, were higher than  $-35^{\circ}\text{C}$  in almost all shapes of the crystals.

## 6. Considerations and Conclusions

The various kinds of unknown and peculiar shapes of snow crystals observed at Syowa Station from the beginning of February 1968 to the end of January 1969 are presented here. Almost all of these shapes are not included in the meteorological classification of natural snow crystals by Magono and Lee<sup>14)</sup>.

Through the observational period, it was recognized that some of these

peculiar shapes of snow crystals were observed when a combination of bullets, bullets and columns were falling. Therefore, some of these peculiar shapes were accompanied by "bullets". Thus, further investigations on the crystal habits of "Bullets" and "Combination of bullets" is necessary to solve the problems of these peculiar crystals. In addition, it is necessary to solve the growth mechanism of the side planes.

To estimate of the growth ranges of these peculiar shapes of snow crystals, the temperatures and the relative humidities of the cloud tops and the surface from the sounding curves for the first approximation were examined. As a result, it was estimated that the growth ranges of the temperature and the relative humidity in the case of "Tetragon with bullets" were from  $-13^{\circ}\text{C}$  to  $-30^{\circ}\text{C}$  and from 75% to 90%, respectively. And also in the case of "Iciclelike crystal", they were from  $-15^{\circ}\text{C}$  to  $-30^{\circ}\text{C}$  and from 70% to 90% and so on. The most attention demanding and important phenomenon was that the minimum temperatures in clouds in which these unknown and peculiar crystals grew, as estimated from sounding curves, were higher than  $-35^{\circ}\text{C}$  in almost all shapes of crystals. The temperature range in which these peculiar crystal were found are not uncommon in the winter seasons in temperate regions. Therefore, the question as to why such shapes and forms are not observed hitherto remains.

Because some of these peculiar crystals are asymmetrical in shape, it is possible to surmise that the crystals may be types of frost growing on and in the surface of snow cover and crevasses. However, the fact remains that no crystals of these shapes were found on the slide glasses under a microscope in typical drifting snow. The shapes of almost all crystals in the drifting snow were exclusively irregular ice particles. Further, it was also very interesting that various kinds of peculiar crystals were observed before and after the cold front passed over Syowa Station.

The angle between the bullet and the center axis of a "Bullet with a side plane" was  $51^{\circ}$  and that between the center axis and the row of bullets of "Assemblage of periodic scrolls with side planes" was  $49^{\circ}\sim 51^{\circ}$ . And the angle between the center axis and the row of bullets of "Periodic combination of bullets" was  $27^{\circ}$ . Furthermore, "Simple tetragon" showed an angle of  $20^{\circ}$ . These degrees of angles of the crystals may be useful for future investigations of artificial snow crystal making.

*Acknowledgements.* The author expresses his hearty thanks to Prof. C. Magono, Department of Geophysics, Hokkaido University, for his suggestions

and advice throughout the course of this study. And the author expresses his sincere gratitude to Mr. M. Murayama, the leader of the 9th Japanese Antarctic Research Expedition and to Mr. T. Sekino, one of the engineer of the expedition for their kind cooperation in the field of the logistics at Syowa Station. The expense of this study was defrayed from the Antarctic Office, the Educational Ministry and supported partially by a Special Fund for Scientific Research from the Educational Ministry of Japan.

### References

- 1) KIKUCHI, K.: Observations of Cloud Physics and Atmospheric Electricity at Syowa Station, Antarctica. (in Japanese). to be published in "Tenki".
- 2) WEICKMANN, H.: The ice phase in the atmosphere. Trans. 273, Ministry of Supply, London. (1948).
- 3) Клинов, Ф.Я.: Бода в атмосфере при низких температурах. Академии Наук СССР. (1960.)
- 4) SHIMIZU, H.: "Long Prism" crystals observed in precipitation in Antarctica. Jour. Met. Soc. Japan, Ser. II, **41** (1963), 305-307.
- 5) MAGONO, C. and S. Tazawa: Design of "Snow Crystal Sondes". Jour. Atmos. Sci., **23** (1966), 618-625.
- 6) NAKAYA, U.: Snow Crystals, natural and artificial. Harvard Univ. Press. (1954).
- 7) KUMAI, M.: A study of ice fog and ice-fog nuclei at Fairbanks, Alaska. U.S. CRREL, Research Report 150 (1964).
- 8) KINGERY, W.D.: Regelation, surface diffusion, and ice sintering. Jour. Appl. Phys., **31** (1960), 833-838.
- 9) KUROIWA, D.: A study of ice sintering. Tellus, **13** (1961), 252-259.
- 10) HOBBS, P.V.: The aggregation of ice particles in clouds and fogs at low temperatures. Jour. Atmos. Sci., **22** (1965), 296-300.
- 11) Mason, B.J. and J. Maybank: The fragmentation and electrification of freezing water drops. Quart. Jour. Roy. Met. Soc., **86** (1960), 176-186.
- 12) EVANS, D.G. and W.C.A. HUTCHINSON: The electrification of freezing water droplets and of colliding ice particles. Ibid. **89** (1963), 370-375.
- 13) STOTT, D. and W.C.A. HUTCHINSON: The electrification of freezing water drops. Ibid. **91** (1965), 80-85.
- 14) MAGONO, C. and C.W. LEE: Meteorological classification of natural snow crystals. J. Fac. Sci., Hokkaido Univ., Ser. VII, **2** (1966), 321-335.
- 15) KOBAYASHI, T.: Vapour growth of ice crystal between -40 and -90°C. Jour. Met. Soc. Japan, Ser. II, **43** (1965), 359-367.
- 16) KIKUCHI, K.: On snow crystals of bullet type. Ibid. **46** (1968), 128-132.

Plate 1

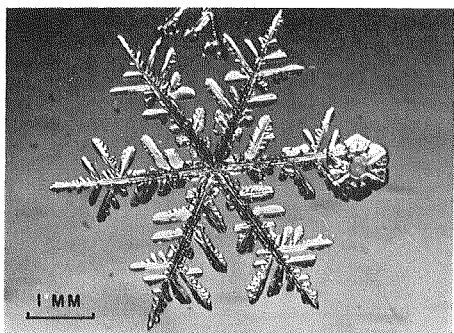

Photo. 1 Ordinary dendritic crystal

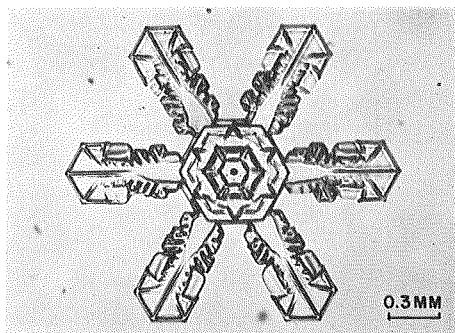

Photo. 2. Crystal with broad branches

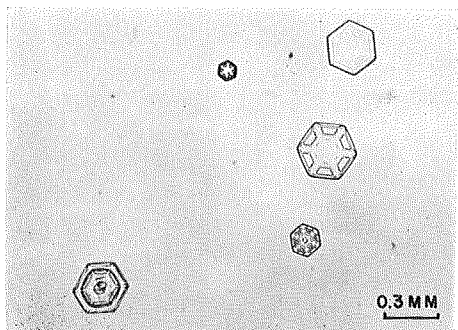

Photo. 3. Hexagonal plates

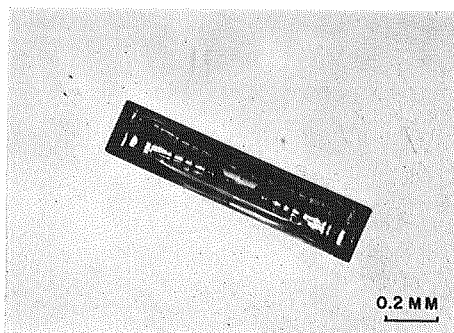

Photo. 4. Hollow column

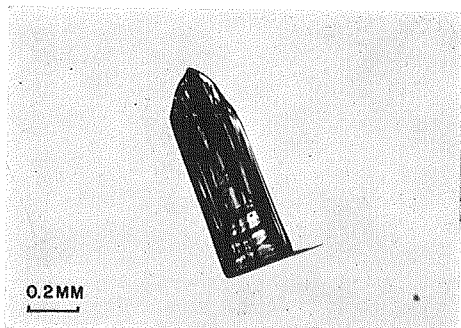

Photo. 5. Hollow bullet

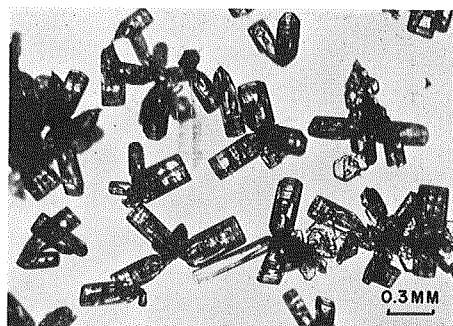

Photo. 6. Combination of bullets

Plate 2

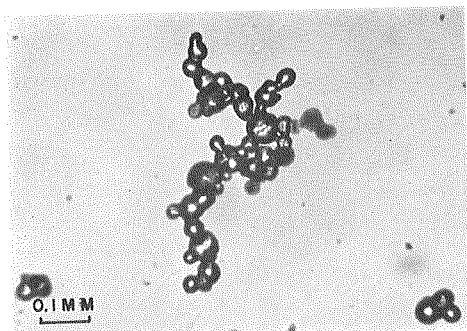

Photo. 7. Sintered frozen cloud particles

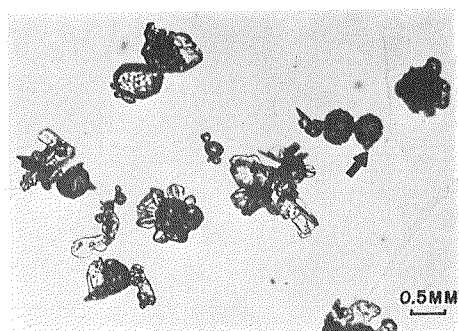

Photo. 8. Sintered frozen cloud particles

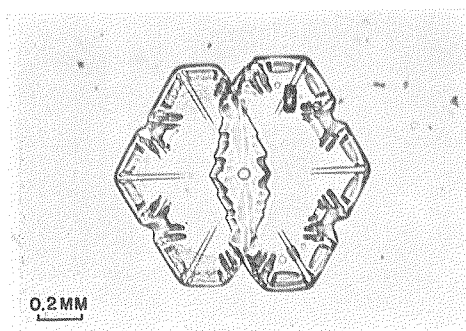

Photo. 9. Double plates

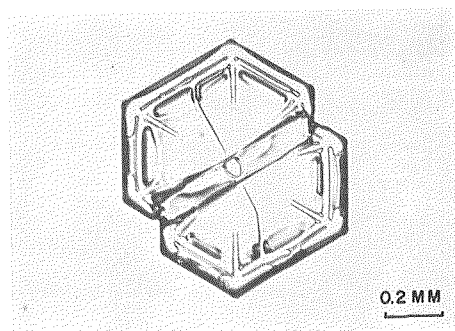

Photo. 10. Double plates

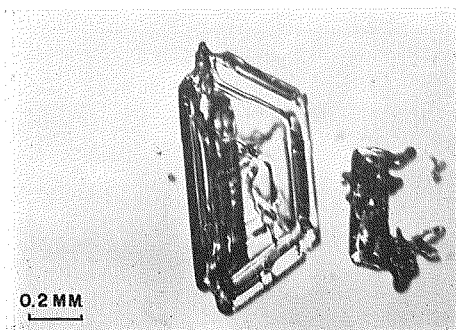

Photo. 11. Crossed plates

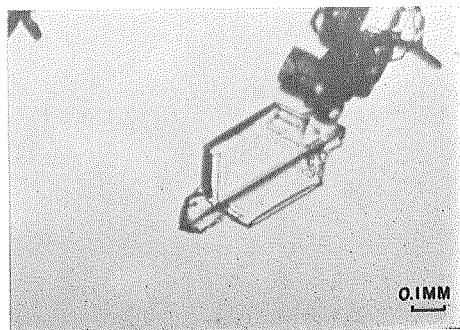

Photo. 12. Crossed plates

Plate 3

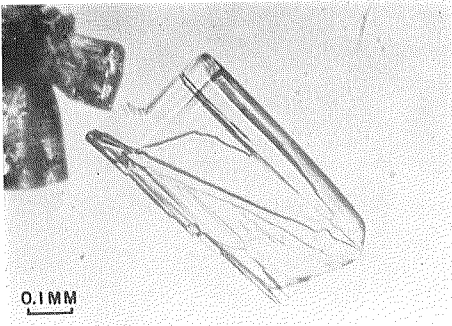

Photo. 13. Simple tetragon

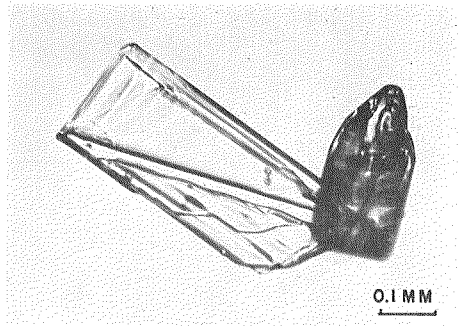

Photo. 14. Simple tetragon

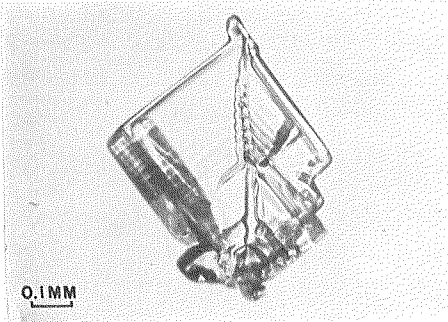

Photo. 15. Tetragon with bullets

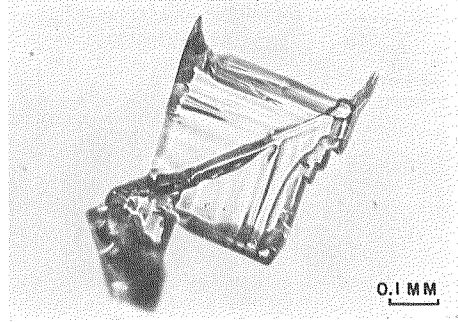

Photo. 16. Tetragon with bullets

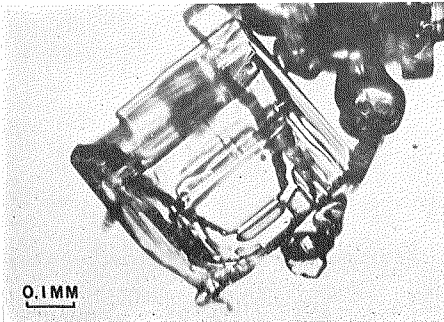

Photo. 17. Skeltonlike tetragon

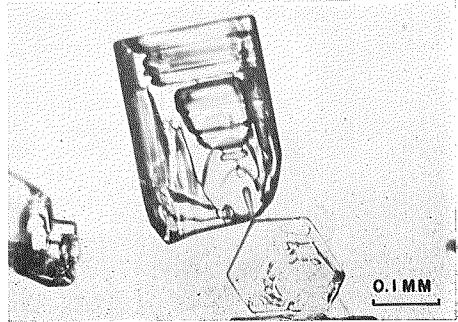

Photo. 18. Skeltonlike tetragon

Plate 4

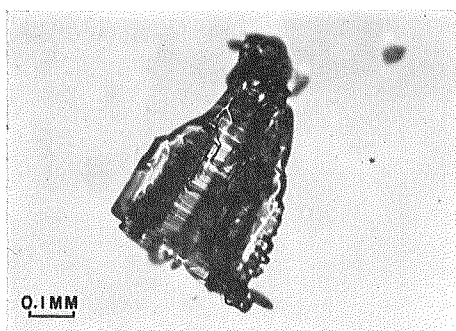

Photo. 19. Scroll crystal of bullet type

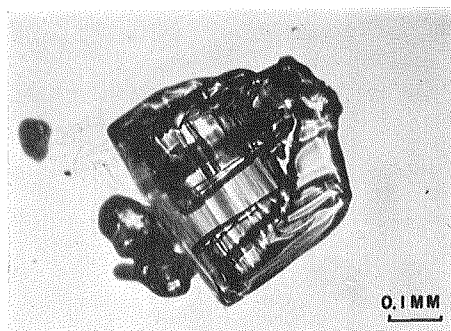

Photo. 20. Scroll crystal of bullet type

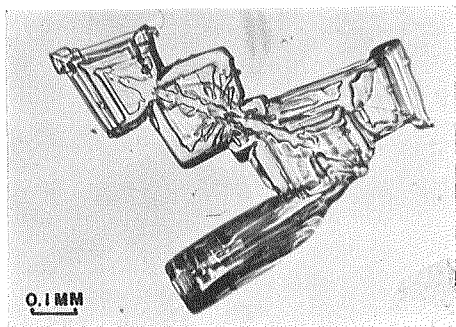

Photo. 21. Bullet with a side plane

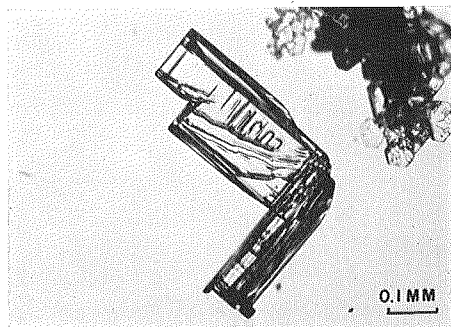

Photo. 22. Bullet with a side plane

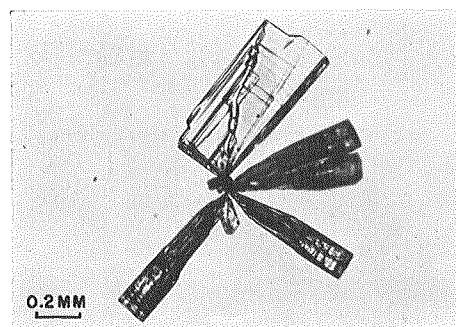

Photo. 23. Combination of bullets and a rectangular side plane

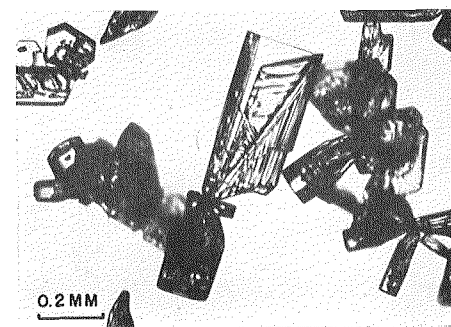

Photo. 24. Combination of bullets and a rectangular side plane

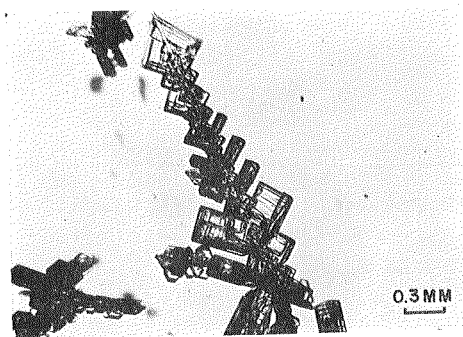

Photo. 25. Assemblage of periodic scrolls with side planes

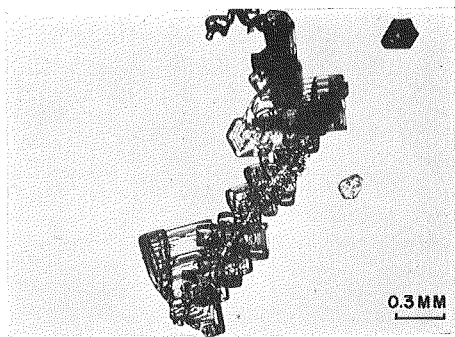

Photo. 26. Assemblage of periodic scrolls with side planes

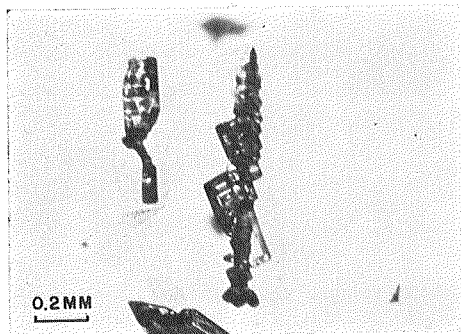

Photo. 27. Periodic combination of bullets

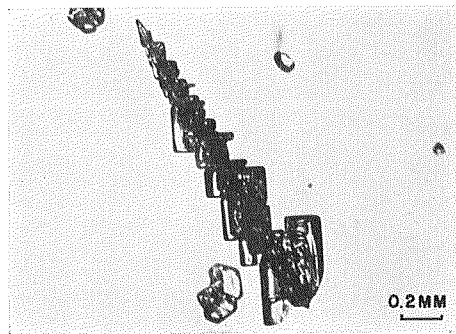

Photo. 28. Periodic combination of bullets

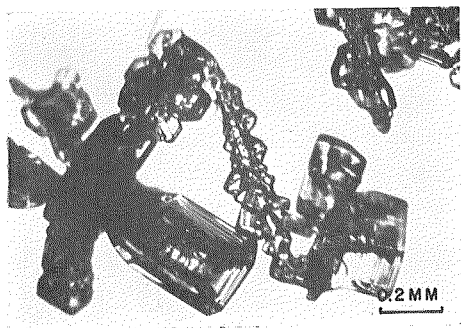

Photo. 29. Iciclelike crystal

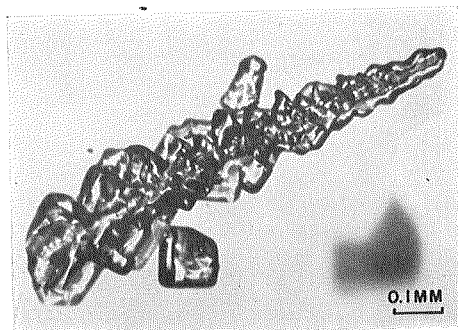

Photo. 30. Iciclelike crystal



Plate 6

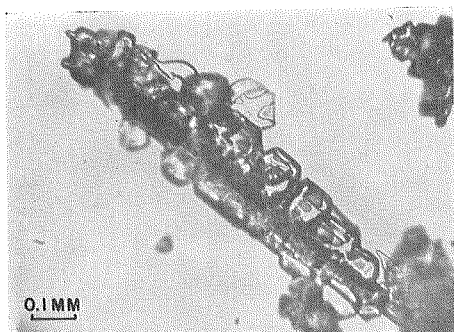

Photo. 31. Scalelike side planes

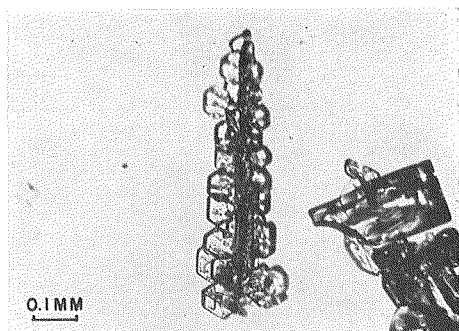

Photo. 32. Scalelike side planes

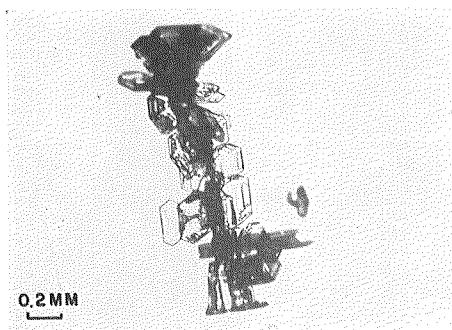

Photo. 33. Scalelike side plane with scrolls

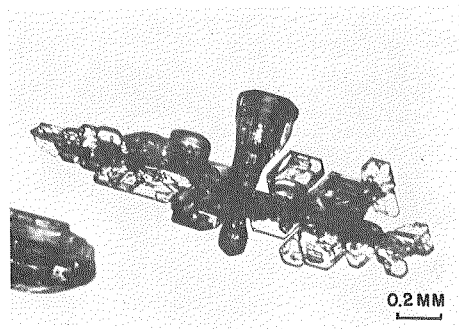

Photo. 34. Scalelike side plane with scrolls

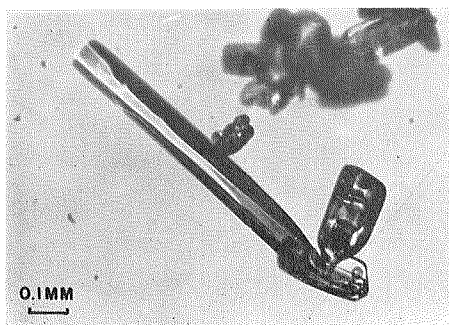

Photo. 35. Combination of bullets with a long bullet

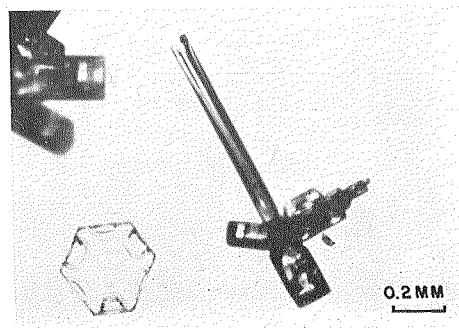

Photo. 36. Combination of bullets with a long bullet

Plate 7

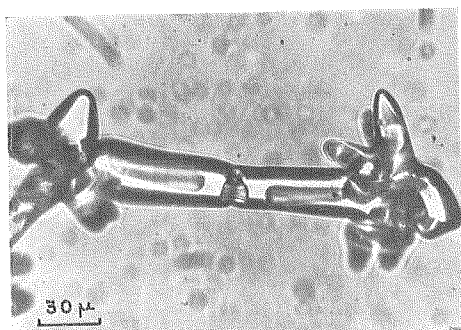

Photo. 37. Bony crystal

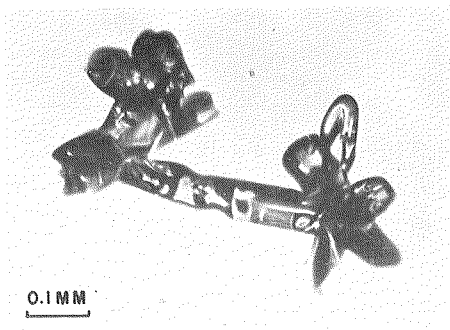

Photo. 38. Bony crystal

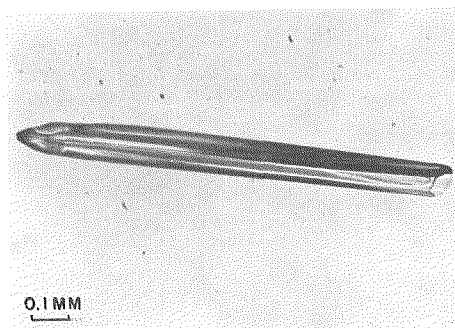

Photo. 39. Long prism with pyramidal faces

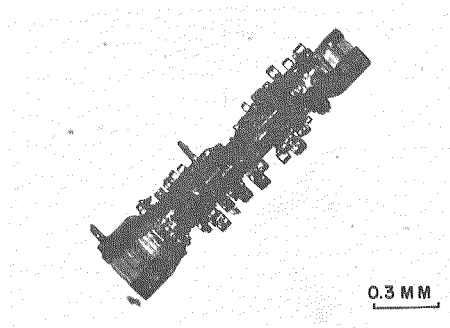

Photo. 40. Rimed scroll

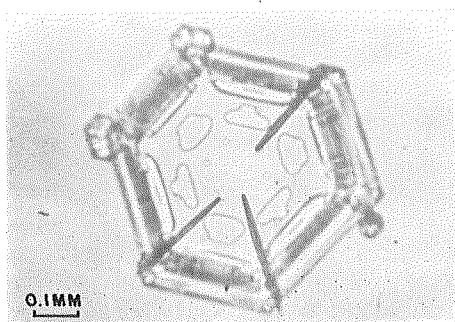

Photo. 41. Plate with spikes

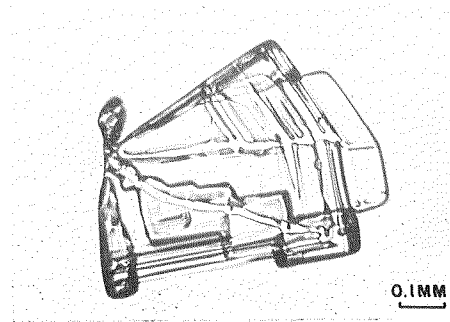

Photo. 42. Pentagon with bullets

Plate 8

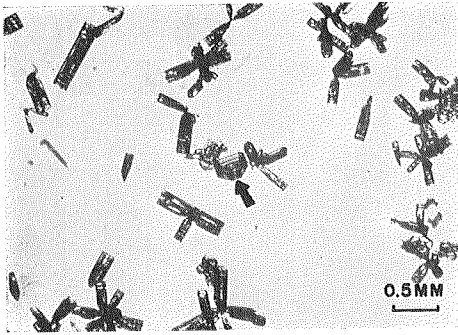

Photo. 43. Hexagonal barrel ?

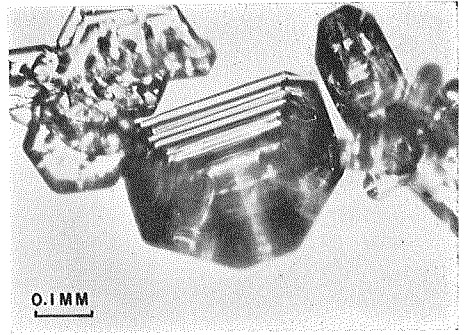

Photo.44. Same as Photo. 43

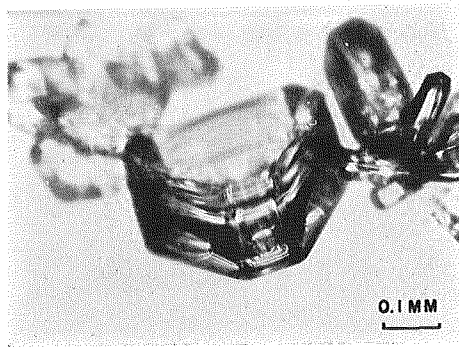
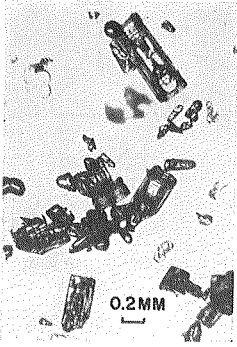
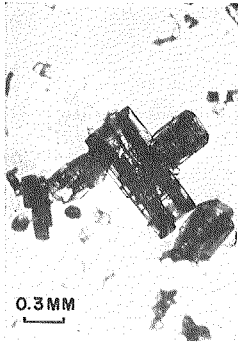

Photo. 45. Same as Photo. 43

Plate 9



(1)



(2)

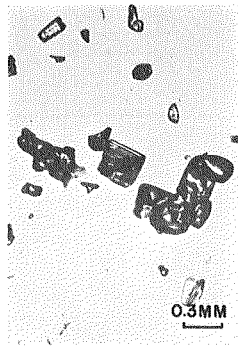

(3)

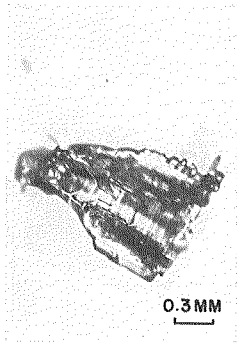

(4)

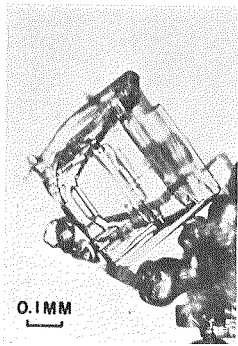

(5)

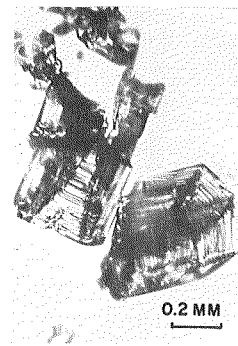

(6)

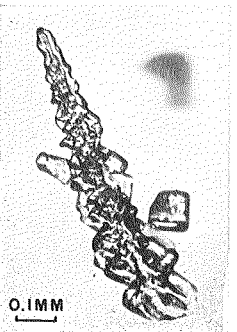

(7)

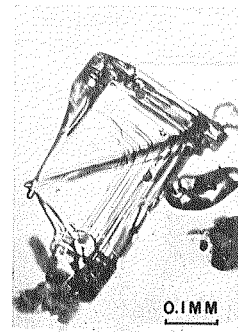

(8)

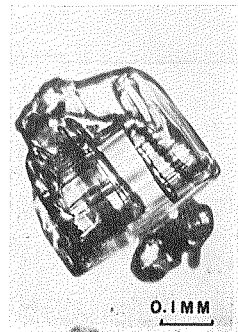

(9)

Plate 10

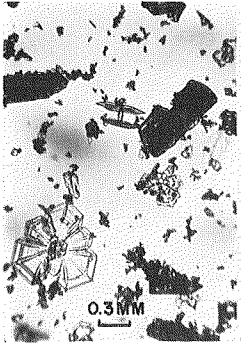

(10)

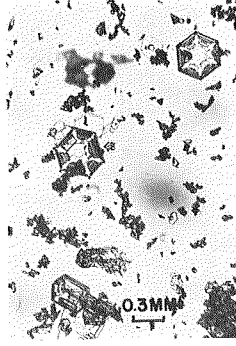

(11)



(12)

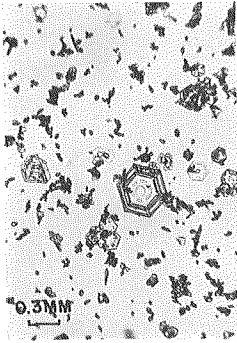

(13)

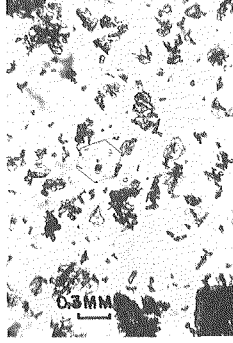

(14)

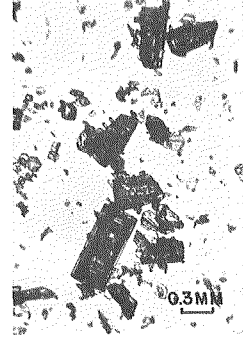

(15)

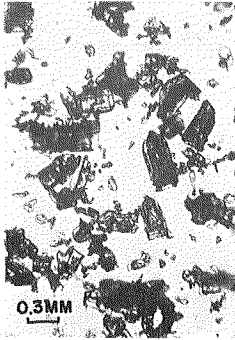

(16)

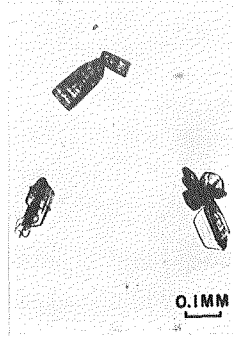

(17)

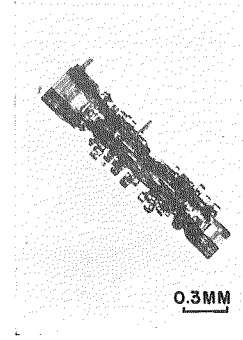

(18)

Plate 11

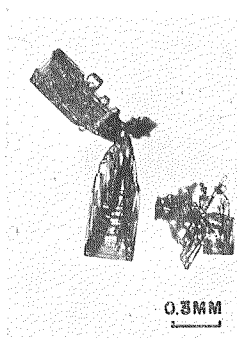

(19)

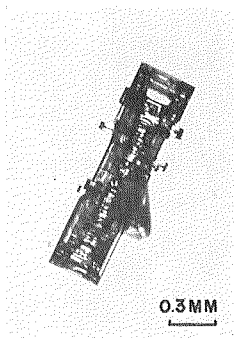

(20)

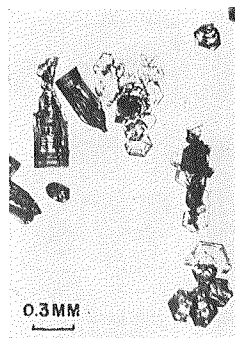

(21)

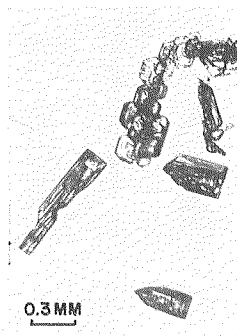

(22)

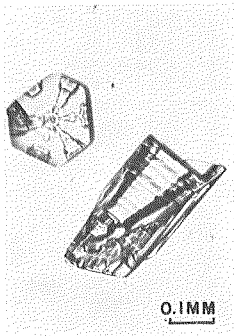

(23)

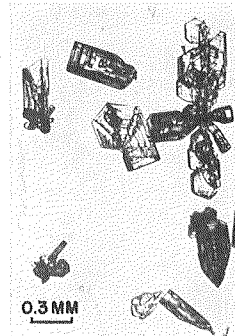

(24)



(25)

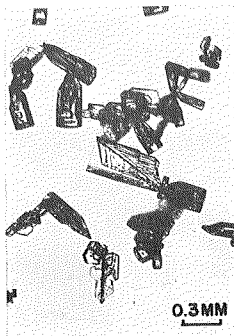

(26)

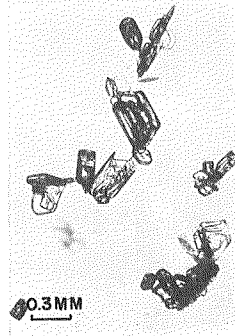

(27)

Plate 12

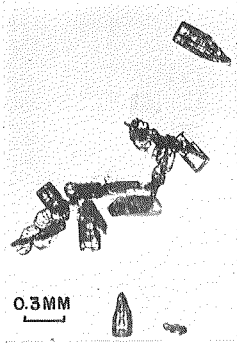

(28)

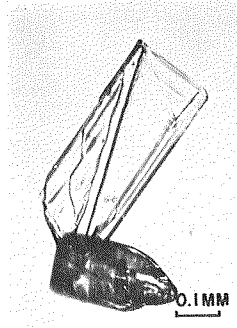

(29)

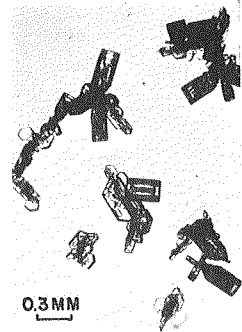

(30)

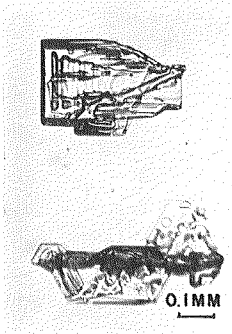

(31)

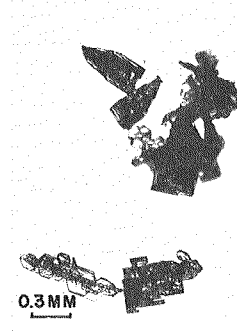

(32)

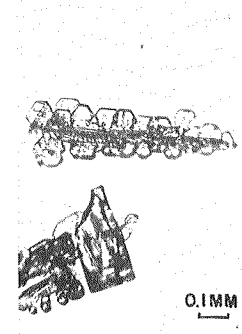

(33)

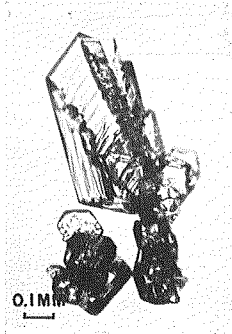

(34)

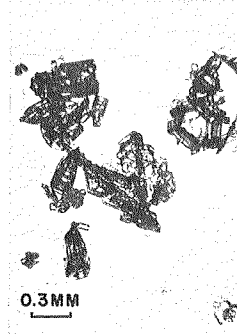

(35)

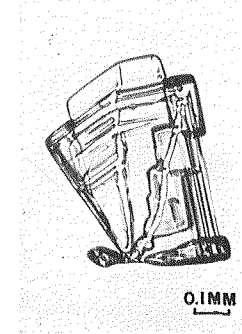

(36)

Plate 13

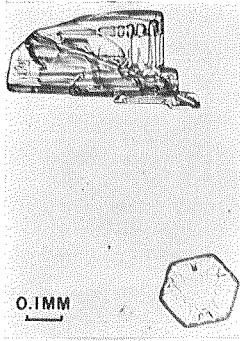

(37)

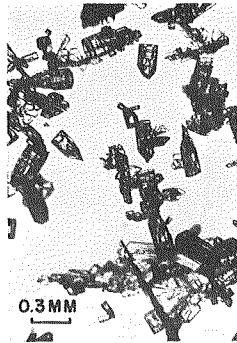

(38)

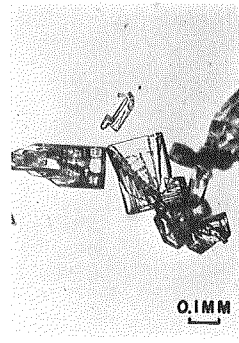

(39)

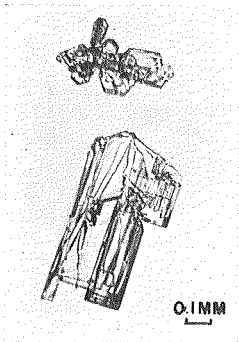

(40)

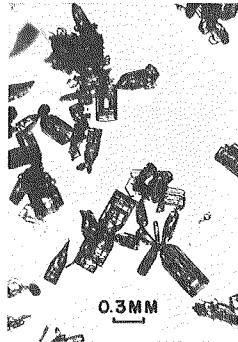

(41)

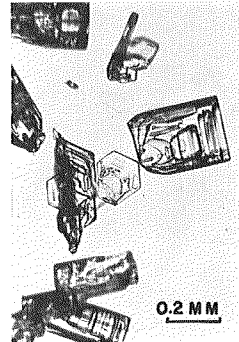

(42)

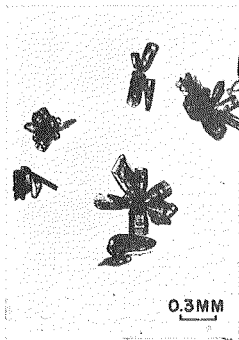

(43)

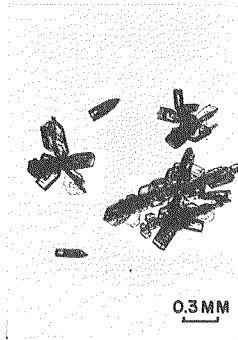

(44)

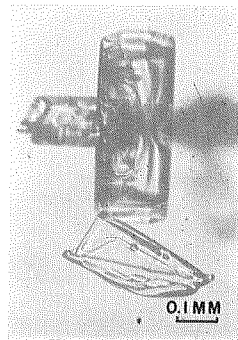

(45)