

Process control by personal computer

Although most of the general-purpose process control systems still use proportional-integral-derivative algorithms, control techniques which have been too expensive or too complicated to implement not long ago are now made possible using a microcomputer.

This article covers the operation, design procedures and the applications of a microcomputer-based digital dynamic control system (d.d.c.) and underlines how the addition of a simple analogue interface on a small personal computer allows the designer to become familiar with the digital dynamic control techniques in a real (not simulated) environment. The system described consists of an eight multiplexed input a-to-d converter, a d-to-a converter with power outputs and a six input adder. Thus multiple feedback controlling only one output variable is possible. Alternative interfaces are also described; their object is acquiring data and simplifying the software which the microprocessor needs to make data conversion.

Digital process control ousts analogue

The history of automatic control, from the use of ingenious pneumatic controllers to the present-day d.d. control systems, has spanned almost half a century. This evolution has not been the result of a continuous transformation but the consequence of an acceleration-stop process which has been technology's main characteristic since the second World War.

Neither has this evolution occurred without controversy: the technological changes have originated many and sometimes serious polarizations in the designer's opinion. They can be classified into two main controversial groups, the first being an immediate consequence of the technological change. Concerning the control hardware selection, it is generally solved assuming that the ultimate decision is purely a marketing decision. Innovations in hardware often act like perturbations in the decision system.

The theory-practice gap evident in many applications constitutes the second controversy and is the most relevant characteristic in the recent history of automatic control. On the other hand, theory and technology have evolved side by side; from the idea of feedback as a starting point, control theory has developed powerful analytical tools and efficient controllers

Professor Bertrán and colleagues are in the Department de Sistemes de Control, Escuela Técnica Superior de Ingenieros de Telecomunicación, Barcelona, where they teach circuit theory and systems control.

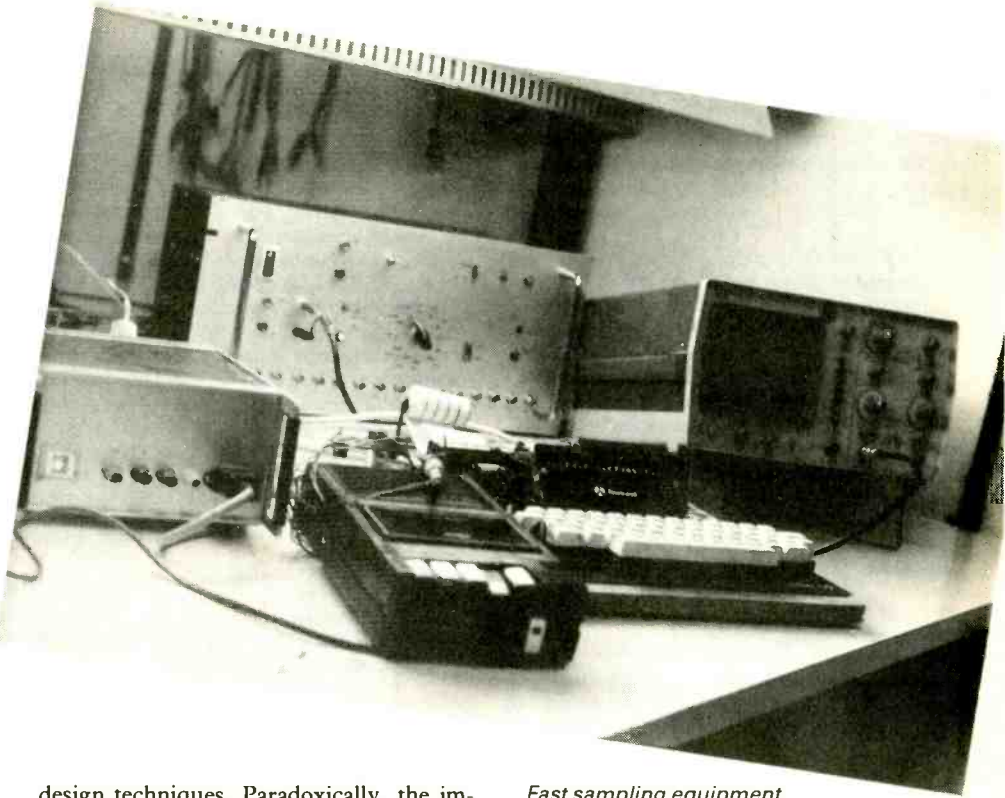

design techniques. Paradoxically, the impact of these achievements has been almost insignificant in the field of industrial applications. Thus p.i.d. action – which has been the main process control algorithm since the beginning of automatic control – still has worldwide acceptance. An inquiry made in USA in 1978 into the control type used by the analogue controllers then in

**by E. Bertrán, L. Martínez,
J. Miguel and I. Munilla**

use revealed that 34 out of 37 listed controllers were p.i.d., either exclusively or with options for proportional-integral or proportional actions. Satisfactory performance in the properly tuned p.i.d. controllers caused other control options to be relegated, whereas electronic technology could have made them possible.

It has not been exclusively a problem of mistrust in the theoretical proposals; an algorithm more sophisticated than p.i.d. implies a more complex and expensive analogue controller. The close relationship between algorithm and hardware complexity didn't allow the practical application of most theoretical models until the introduc-

Fast sampling equipment together with rest of the microcomputer system – Rockwell Aim 65 keyboard, external memory, power supply and oscilloscope.

tion of the digital computer. But not until few years ago could designers count on a real, economical and flexible alternative to the use of p.i.d. analogue controllers. Thus microcomputer-based digital control is competitive even in the area of small applications.

In a direct digital control system the microprocessor performs the controller tasks. The control becomes control by program instead of hardware control by analogue filter. Algorithm complexity is no longer related to the system price but to the computation time, namely to the output delay which constitutes a basic parameter in closed-loop systems. Neither does control sensitivity depend on filter component tolerance, but on computation accuracy (round-off, number of bits representing every coefficient, etc.). Old restrictions disappear while new design factors arise. And finally, software flexibility allows selection of the appropriate algorithm, adoption of a control strategy which allows alternatives (for instance, starting and

steady-state), program linearization of transducer characteristics, etc.

The small personal computer is a very useful tool for designers' practical initiation into d.d.c. techniques and it is mostly used for running either standard programs (e.g. video-games, file-handling) or the users program. Its outer communication is basically limited to the input and storage of data and programs, and to the display. By adding appropriate input/output devices and by means of a special program, this computer can perform the real-time control of any outer device. The small personal computer can therefore be used as a calculator (analysis or design programs), as a simulator (simulation programs with graphical results), and as a controller (real-time control programs).

Equipment scheme and performance

An analogue control interface for the Rockwell Aim-65 microcomputer system has been implemented though the design is easily adaptable to any other computer. It uses eight multiplexed inputs and one output, and has been designed to control low-power devices. Its structure corresponds to the very general functional scheme of Fig. 1.

The analogue input consists of several modules whose performance is controlled by the microcomputer through an input/output port. The multiplexer selects one of its input signals and applies it to the sample and hold circuit whose aim is holding a sample at a fixed voltage during the a-to-d conversion time interval. The converter provides a digital representation of the value of every sample by using a limited number of bits (eight in this case). A decoder allows the microcomputer to read the digital samples through a specific memory address which belongs to the memory space not occupied by rom, ram or other addressable devices. The analogue output consists basically of a d-to-a converter. The microcomputer writes the digital values in an output port which is connected to the above-mentioned d-to-a converter. Finally, an analogue adder

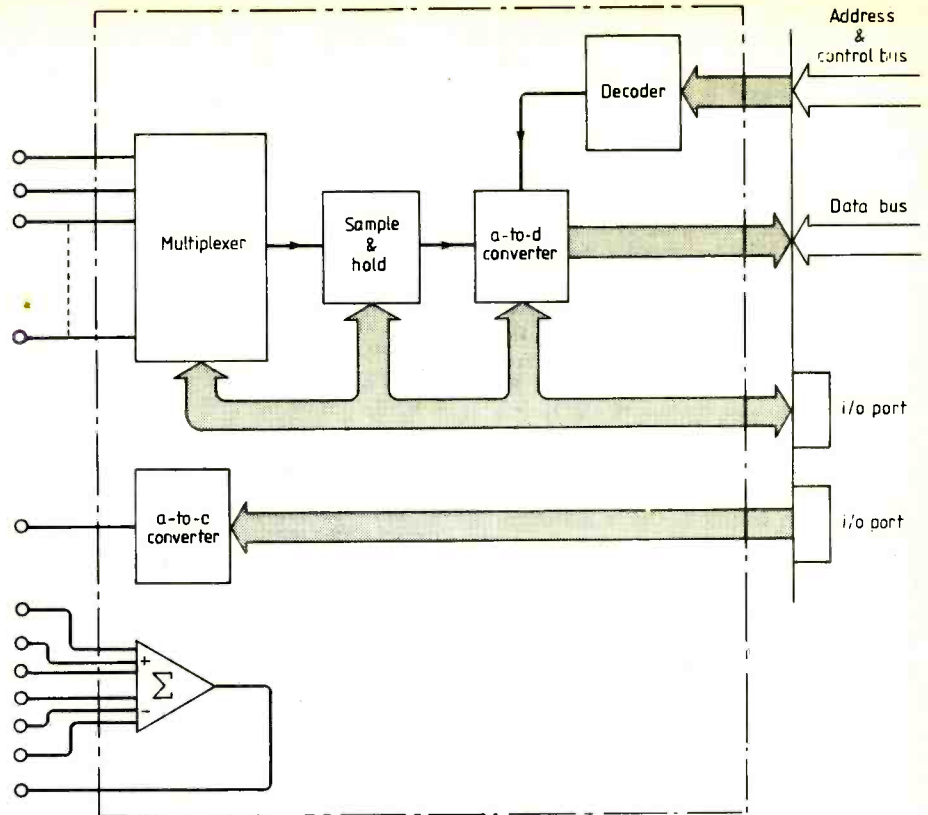

Figs 1 & 2. Functional scheme of the analogue interface (above) together with its detailed system performance (below).

(Σ) with three adding and three subtracting inputs has been incorporated.

The microcomputer system performs the control of the analogue input through the so-called v.i.a., a set of programmable input/output ports, owing to the use of the AIM-65 system. The sequence of tasks for the acquisition of one sample is given below:

- 1 *Programming of v.i.a. port A*, implies that PA_0 , PA_1 , PA_2 and PA_4 will be the outputs and PA_5 the input.
- 2 *Selection of an analogue input*. According to the binary combination PA_1 , PA_0 , PA_2 , one of the eight possible inputs is chosen.
- 3 *Order of sampling*: A 'one' is loaded in PA_3 .
- 4 *Acquisition time*. A minimum time t_A of

$5\mu s$ is needed to ensure that the sample and hold output be equal to the input.

5 *Order of holding*. A '0' is loaded in PA_3 .

6 *Delay of opening*. A minimum time t_H of $1\mu s$ is required to ensure a fixed voltage in the sample and hold output.

7 *Beginning of conversion*. Once the input signal analogue sample is obtained, i.e., t_H microseconds after the 'hold' order, the microcomputer gives the order 'begin of conversion' to the a-d converter by loading a '0' in PA_4 .

8 *End of conversion*. The microcomputer remains in a waiting state until the end of digitization, indicated through PA_5 . Therefore it will test either continuously that bit state. By varying the jumper position, the microcomputer may execute other program tasks without making any test since it would receive the end of conversion indication as if it were an interrupt request.

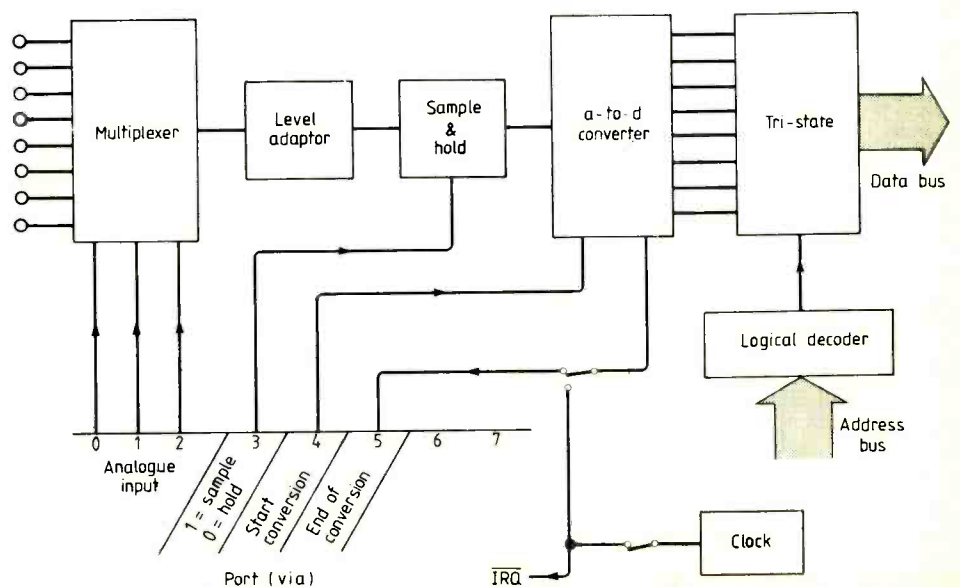
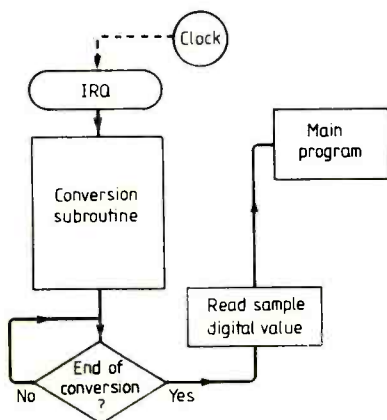

9 Reading of the sample. Once the end of a-to-d conversion is verified, the microcomputer reads the results in a memory position whose address is determined by the logical decoder. This decoder also activates the tristate buffer connected between the a-d converter output pins and the data bus. Fig. 2 shows the system performance when the sampling period is fixed by an external clock and the jumper applies the signal 'end of conversion' to PA₅. Port A is assumed to be initially programmed. Whenever a new clock edge is applied, the task (main program) is interrupted to execute the a-to-d conversion subroutine. As regards the analogue output, the R-2R d-a converter is directly coupled to v.i.a. port B which is output-programmed. Therefore, an analogue signal extracting program is an instruction or a set of instructions that can modify the contents of Port B. A detailed scheme of the acquisition and extracting modules for analogue signals is shown in Fig. 3.

Design alternatives

A similar equipment incorporating two cascaded monostables is shown in Fig. 4. Once the microcomputer gives the order of sampling, the orders 'hold' and 'beginning of conversion' are automatically generated after the necessary opening and holding times. This solution however, is not always optimal. In fact, in many cases it can be much more interesting not to use the monostables even at the cost of generating successively all the orders by microcomputer.

Another contribution of this equipment is the presence of a programmable gain amplifier which offers greater versatility by conforming the optimal range of the sample and hold performance to different possible multiplexor inputs.

Reading the digital code corresponding to the input analogue signal can be made in different ways. Fig. 5 describes the two most important ones, consisting either in the reading of the data as though it were a ram position, or in the reading through an i/o port. Choice of the method will depend on the application and, above all, on the limitations of the microcomputer.

In some applications, like supervision or processes identification, it can be interesting to dispose of a sampling unit with specific services. Fig. 6 shows the functional block diagram of an equipment for fast sampling which has been developed in the Department of Systems Control (E.T.S.I.T., Barcelona). Its performance also differs from the former because the

Fig. 3. Under control of port A, analogue input signals are processed by the multiplexer, amplifier and sample and hold circuit, and digitized by the AD570. Sample digital codes reach the data bus through the three-state 74245. DAC-08 performs the d-a conversion. An error adder is built separately with standard op-amps (LM324).

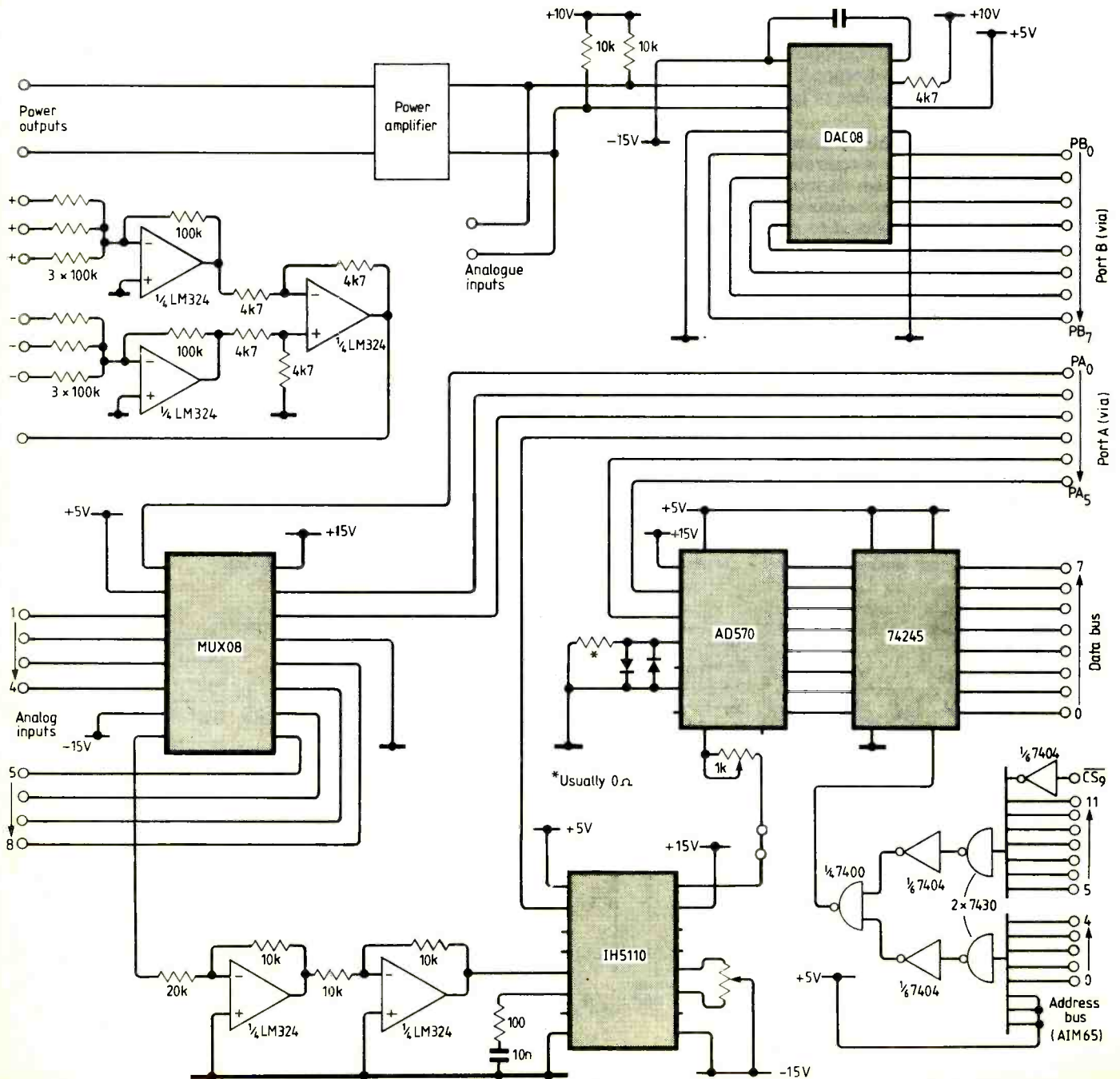

microcomputer initializes a counter by loading the number of consecutive wanted samples from the input signal. These samples are stored in the consecutive positions of a ram at the maximum speed allowed. While the input signal is being sampled, a d.m.a. controller carries the microcomputer to a state of waiting, this taking place only if the computer tries to accede to the ram, which is shared both by the computer and the acquisition system. Thus the information loss coming from the multiplexer is avoided.

With this equipment the rate of sampling can also be selected either automatically or by hand. It also allows sporadic transient phenomena to be registered in the ram, and pulse trains as well as different analogue signals to be generated.

Real time control constitutes the most stringent demand of the afore-described equipments. Computation lags, conversion times and operation accuracy now acquire a relevant design significance. So the basic criteria determining the microcomputer assignment can be classified as follows:

Precision grade — is proportional to the number of bits representing samples and coefficients. Quantization is modelled like an added noise to the

Fig. 4. Modified acquisition system automatically provides the delayed hold and beginning of conversion signals which follow the microcomputer sampling order. Two options of end-of-conversion indication can be switch-selected: a flag (bit 5) in the i/o port or an interrupt generation.

Fig. 5. Digital code-reading options: memory mapped or i/o mapped.

Fig. 6. This fast sampling equipment exploits the automatic generation conversion signal shown in Fig 4. The samples can be acquired by blocks of selectable length under control of the direct memory access arbiter.

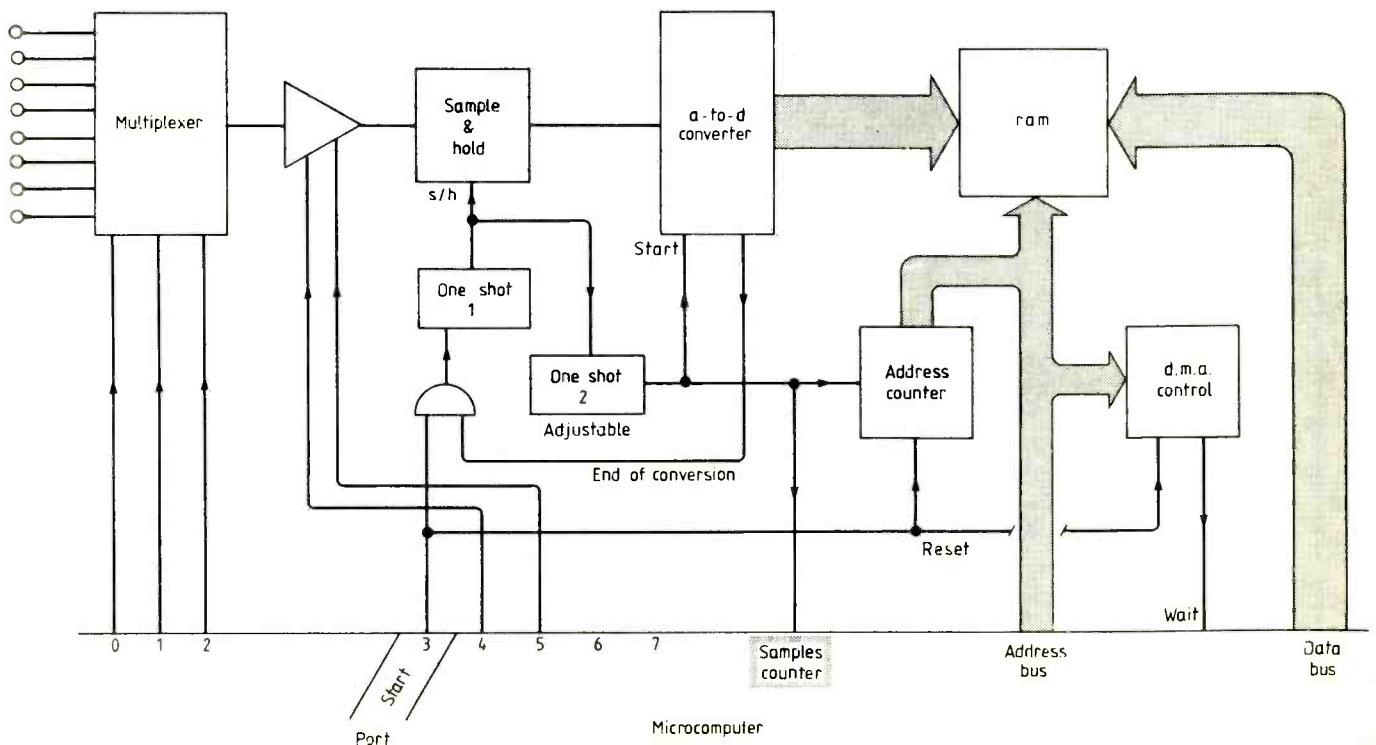
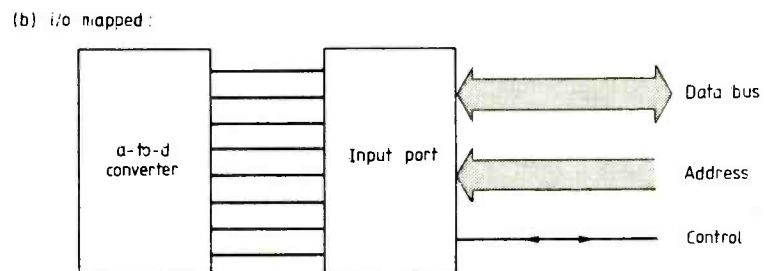
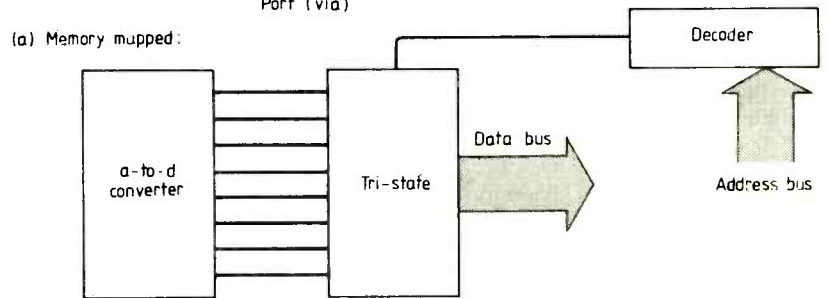
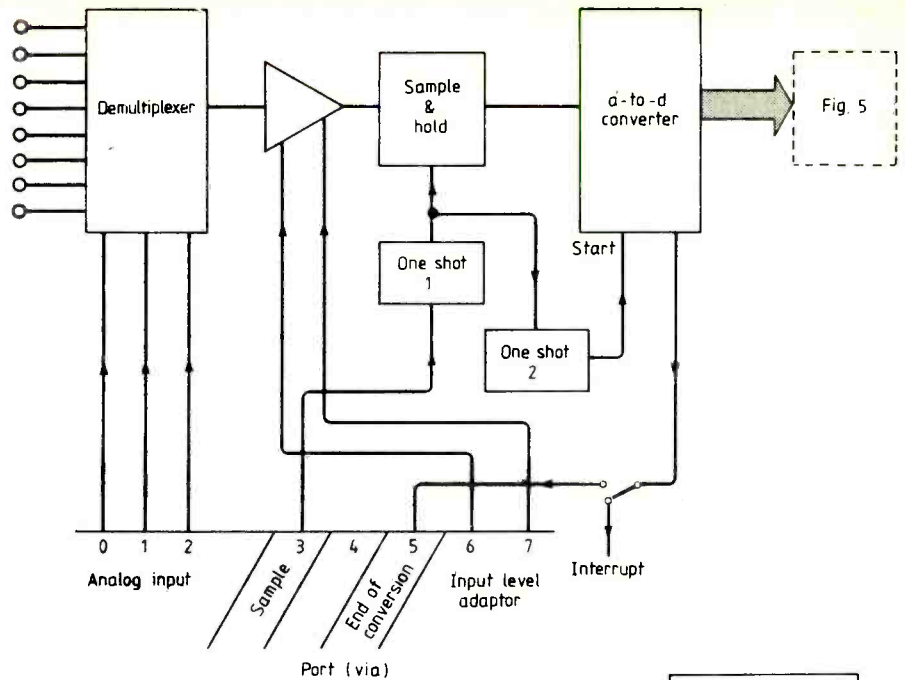

designed ideal filter. It represents the round-off and truncation, both from calculations and from the filter coefficients effective value.

Maximum processing speed — is the inverse of the minimum possible sampling period. This period is calculated by considering the a-to-d conversion time, the control algorithm computation time and the d-to-a conversion time.

Precision criteria

By assuming a uniform distribution of the input samples along the whole amplitude range, an equation can be derived by relating the number of bits (n) used in the a-to-d conversion to the quantization signal-to-noise ratio in the input filter:

$$S/N_q \approx 6n \text{ (dB)}$$

This equation applies exactly to an eight-bit converter. In general, the noise caused by internal operations can be neglected because calculations are usually made with a bigger precision (number of bits) than that used in converters. As regards the filter coefficients, if these have been calculated with a Q digits precision, P bits must be used to maintain that precision. This

Fig. 7. From the digital filter specification, $D(z)$, its corresponding recurrence equation can be obtained. This equation can be written in a more convenient form, substituting each digital sample by its N-bit two-complement representation. Computations will be greatly simplified using precalculated values of F as a function of $x_j^k, x_j^{k-1}, y_j^{k-1}$, (x_j^k being the j-bit of the digital sample $x(k)$, etc.).

Fig. 8. Using distributed arithmetic, the processing speed of an 8-bit microcomputer can be easily multiplied by a factor of 100. 16-bit microcomputers normally include a powerful set of instructions that reduces the differences between the distributed and conventional arithmetic processing. Digital signal processing microprocessors are devices specially suited to signal processing, reaching thus the highest possible speed.

yields the following condition:

$$P \geq 3.3Q.$$

To express the sign, a supplementary bit is used so coefficients internally will need P+1 bits.

If a high-order filter is implemented, then it will be useful to decompose it into second-order sections, either series or parallel-coupled. Thus, global filter behaviour will be less sensitive to quantization errors in computations or in coefficients.

Speed criteria

By using a high-level language (Basic, Fortran, PL1, Pascal, etc.) internal operations are made with great accuracy, and as a consequence processing speed is reduced. On the other hand, using assembler language makes the speed increase at the expense of implementing operations with large errors. This is due to the limitation to eight or 16 bits in the internal representa-

tion, which simplifies the operations; otherwise, speed would be also reduced.

A high processing speed without loss of precision can be obtained by means of a distributed arithmetic. Multiplications are substituted by accesses to table containing calculated values and additions, Fig. 7. Therefore, the best services of an eight-bit standard microprocessor can be obtained at the expense of employing a great memory space (look-up tables). Thus, the antonym speed-precision changes into memory occupation-precision while maintaining the speeds. An example of the effective minimum sampling times with the AIM 65 and the equipment of Fig. 1 are

- 0,2 seconds (Basic and conventional arithmetic)
- 1 millisecond (assembler and eight-bit distributed arithmetic).

These times include the conversions and the internal processing of a second-order correcting filter.

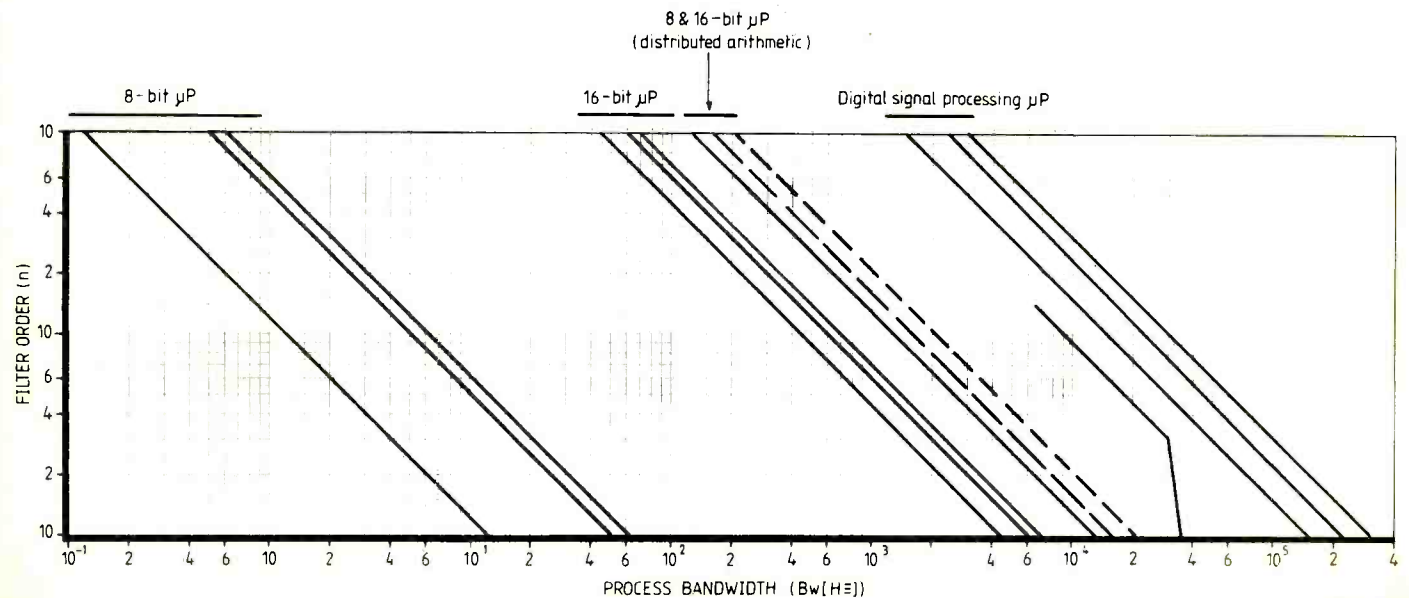
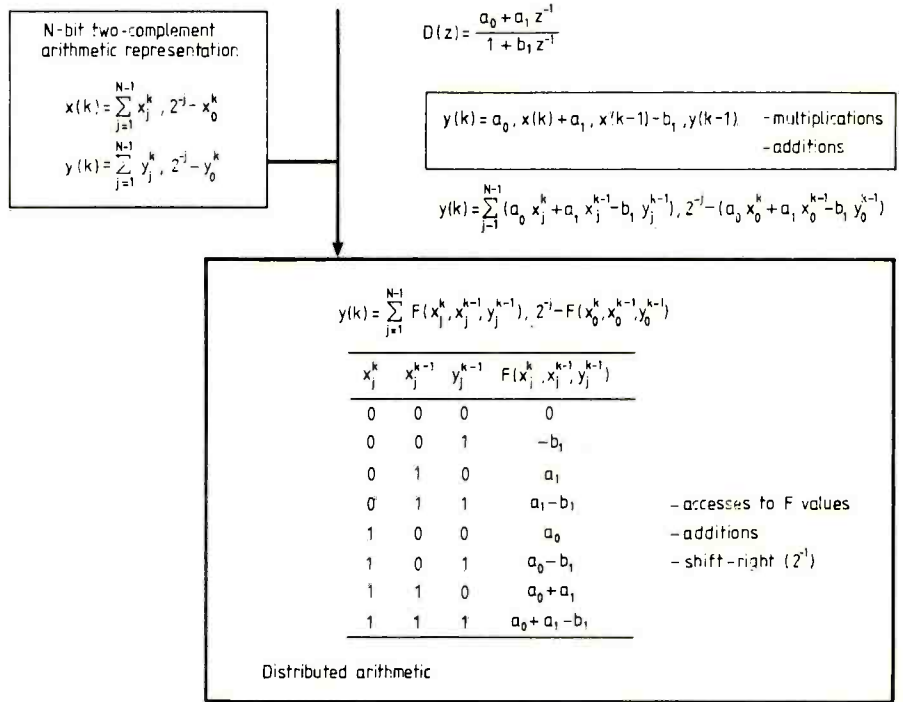

The microcomputer services can be evaluated when implementing a second-order filter; on the other hand, the microcomputer maximum processing speed for an nth-order filter will result from extrapolation as follows:

$$T_n \approx \frac{n}{2} \cdot T_2.$$

This equation means that the processing time of an nth-order filter (T_n) will be approximately $n/2$ times the processing time of a second-order filter (T_2). Decomposition in second-order sections, which is reasonable from the point of view of sensibility, justifies this estimation.

The process bandwidth (B) is a particularly useful parameter in the analysis of the microcomputer applicability to a particular case. This gives a measure of the process response speed to the control signal; a response time of 1 second implies $B \approx 1\text{Hz}$; 1 millisecond corresponds to $B \approx 1\text{kHz}$. According to the sampling theorem, this bandwidth will be related to the processing time as

$$B < \frac{1}{2T_n} = \frac{1}{nT_2}.$$

This condition allows the maximum bandwidth to be determined once the processing time of a second order filter (T_2) and the correct order are known. Figure 8 shows the results obtained in an approximate evaluation for different microprocessors. An important factor in the evaluation of B is the margin for the Nyquist's condition. For instance, $B < 1/10nT_2$ implies that the consequences of the delay computation on the controlled-system performance can be neglected.

Application examples

The main connections in the equipment in Fig. 3 are used for position control of a d.c. servomotor in Fig.9. Position feedback is obtained through the potentiometer transducer.

Fig.10 represents the functional block diagram of the control system. By using the

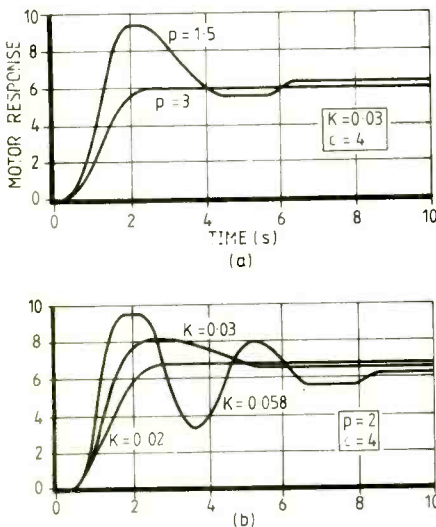

Fig. 11. Motor responses to a six-volt step in the set-point ($p=1.5;3$) - (a) compared with ($k=0.02, 0.03, 0.58$) - (b).

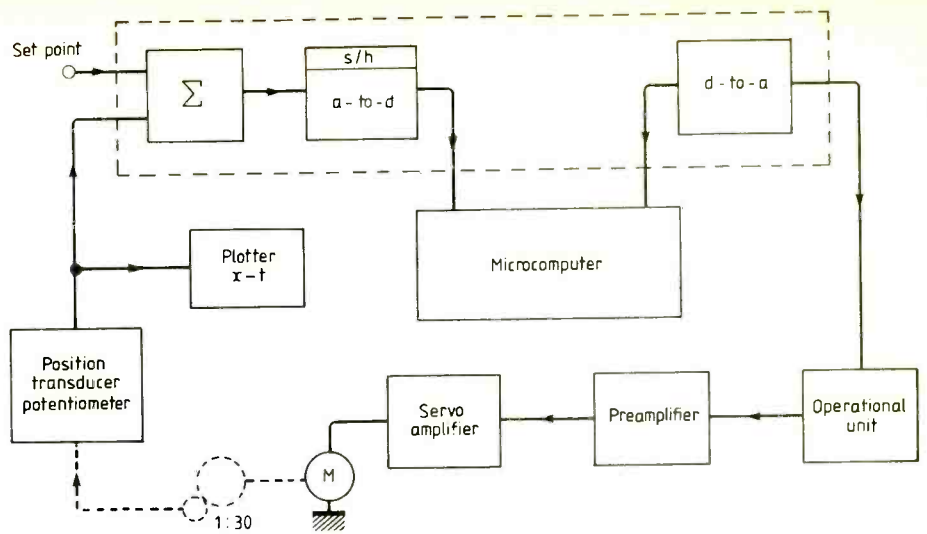
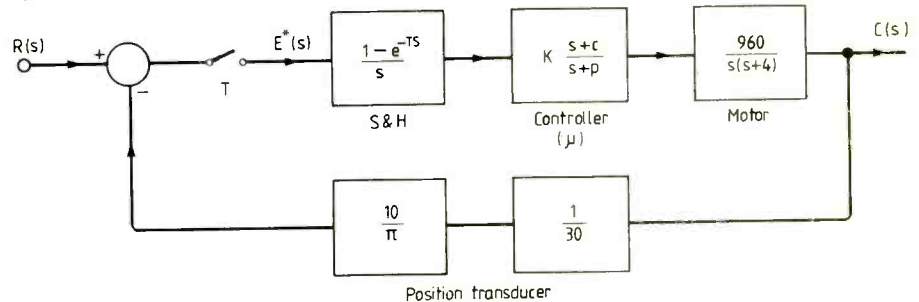

Fig. 9. Schematic representation of a laboratory experience intended to test the performance of the equipment described in Fig. 3 in the position control of a d.c. servomotor.

Fig. 10. Functional model block diagram of the control system implementation of Fig. 9(a).



bilinear transformation a lag-lead controller has been programmed in the microcomputer, with the transfer function

$$G_a(s) = K \frac{s+c}{s+p}.$$

Finally motor responses to a six-volt step in the set-point have been obtained for different values of p , Fig.11(a), and K , (b). In spite of the simplicity of this system, it has not been difficult to verify

the importance of the computation time which must be reflected as a transport lag in the system. In fact, if the mechanical time constant of the motor is 0,38 seconds and the controller program execution time 0,16 seconds, Nyquist's condition will be only strictly accomplished. By comparing the real with the simulated response plots, it can be verified that only one of those simulated is correct - the one considering computation delay. WW

EVENTS

August 25-28

Acorn Computer Show (including the launch of the Electron); Cunard International Hotel, Hammersmith Broadway, London. Details from Susan Phipps, Telephone: 01-390 1612.

September 2-4

September Satellite Weekend: organised by the Institute of Broadcast Sound at the BBC Engineering Training Department, Evesham. Details from Jeff Baker, 14 Meadow Close, Marlow, Bucks.

September 2-11

Funkausstellung 83: International audio and video fair. Exhibition grounds and International Congress Centre, Berlin. AMK Berlin, Postfach 1917 40, Messedamm 22 D-1000 Berlin 19.

September 5-9

Many local further education colleges are enrolling for Radio Amateurs' Courses during this week.

Radio Spectrum Conservation

Techniques: IEE International conference, University of Birmingham. IEE, Tel: 01-240 1871 Ext 222.

September 6-8

Electronic Displays, Exhibition and conference, Frankfurt Intercontinental Hotel. Network Exhibitions. Tel: 028 02 5226.

September 6-10

Inteltec 83/Swissdata 83. Two exhibitions at the Swiss Industries Fair Halls, Basle, on industrial and technical electronics and on data processing in technical applications: SMB, CH-4021 Basel, Messeplatz, Switzerland.

September 13-15

Testmex 83: Test and measurement instrumentation technology, exhibition at the Grosvenor House Hotel, Park Lane, London. Details from Evan Steadman Communications, Tel: 0799 22612.

Continued on page 72