

Optimal Sizing of a Hybrid Grid-Connected Photovoltaic and Wind Power System

Arnau González, Jordi-Roger Riba*, Antoni Rius, Rita Puig

Escola d'Enginyeria d'Igualada, Universitat Politècnica de Catalunya, Pla de la Massa 8, 08700 Igualada, Spain

*Corresponding author. Tel.: +34 938035300; fax: +34 938031589. E-mail address: jordi.riba@eei.upc.edu

Abstract—Hybrid renewable energy systems (HRES) have been widely identified as an efficient mechanism to generate electrical power based on renewable energy sources (RES). This kind of energy generation systems are based on the combination of one or more RES allowing to complement the weaknesses of one with strengths of another and, therefore, reducing installation costs with an optimized installation. To do so, optimization methodologies are a trendy mechanism because they allow attaining optimal solutions given a certain set of input parameters and variables. This work is focused on the optimal sizing of hybrid grid-connected photovoltaic – wind power systems from real hourly wind and solar irradiation data and electricity demand from a certain location. The proposed methodology is capable of finding the sizing that leads to a minimum life cycle cost of the system while matching the electricity supply with the local demand. In the present article, the methodology is tested by means of a case study in which the actual hourly electricity retail and market prices have been implemented to obtain realistic estimations of life cycle costs and benefits. A sensitivity analysis that allows detecting to which variables the system is more sensitive has also been performed. Results presented show that the model responds well to changes in the input parameters and variables while providing trustworthy sizing solutions. According to these results, a grid-connected HRES consisting of photovoltaic (PV) and wind power technologies would be economically profitable in the studied rural township in the Mediterranean climate region of central Catalonia (Spain), being the system paid off after 18 years of operation out of 25 years of system lifetime. Although the annual costs of the system are notably lower compared with the cost of electricity purchase, which is the current alternative, a significant upfront investment of over \$10M – roughly two thirds of total system lifetime cost – would be required to install such system.

Keywords—Grid-connected hybrid renewable energy system, life-cycle cost, sizing optimization, solar photovoltaic power, wind power

NOMENCLATURE

$V_{H,t}$	Estimated wind speed at height H	$pvNumber$	Number of PV modules installed
$V_{H_0,t}$	Measured wind speed at height H_0	$wtNumber$	Number of wind turbines installed
H	Wind turbine rotor height	P_{module}	Nominal power of PV modules
H_0	Wind speed measurement height	$P_{turbine}$	Nominal power of wind turbines
N	System lifetime	NPV	Net Present Value
Y_{wt}	Wind turbine lifetime	$C_{investment}$	Cost of system initial investment
Y_{inv}	Solar PV DC – DC converter lifetime	$NPV_{O\&M}$	Cost of system Operation & Maintenance (O&M)
IR	Interest rate	NPV_{repl}	Cost of system' components replacement
TR	Spain's Value Added Tax (VAT) rate	$NPV_{electricity}$	Electricity selling and purchasing balance
g	General inflation rate	$NPV_{endLife}$	Profit from equipment sale at end of life
$g_{electricity}$	Electricity selling price inflation rate	$C_{O\&M,k}$	Cost of O&M of component k
g_{wt}	Wind turbines selling price inflation rate	C_k	Acquisition cost of component k
g_{inv}	Converter selling price inflation rate	g_k	Expected inflation rate of the acquisition cost of component k
L_{g_wt}	Cost reduction limit due to technological maturity for wind turbines	Y_k	Component k lifetime
L_{g_inv}	Cost reduction limit due to technological maturity for converters	Y_{gk}	Number of years required for technology k to reach technological maturity
C_{PV}	PV capital cost	N_{replk}	Total number of replacements of component k during system lifetime

C_{WT}	Wind capital cost	$N_{first_{repl},k}$	Years that the price of component k is changing at g_k inflation rate
C_{INV}	Converter capital cost	$L_{g,k}$	Cost reduction limit of technology k at a point of maturity
$C_{PV_{fixed}O\&M}$	PV fixed O&M costs	NPP	Net power production
$C_{WT_{fixed}O\&M}$	Wind fixed O&M costs	P_{PV}	Power production of PV modules
$C_{PV_{var}O\&M}$	PV variable O&M costs	P_{WT}	Power production of wind turbines
$C_{WT_{var}O\&M}$	Wind variable O&M costs	$demand$	Electricity demand
C_{pool}	Electricity market price	$PopulationSize$	Size of GA population
C_{electr}	Electricity retail price	$numberOfVars$	Number of independent variables of GA fitness function
$pvArea$	Area covered by PV modules	$EliteCount$	Counting of GA elite (best-fit) individuals
$panelArea$	Area covered by each PV module		

1

2

1. INTRODUCTION

3

4

5

6

7

8

9

10

11

12

13

14

15

16

17

18

19

20

21

22

23

24

25

26

27

28

29

30

31

32

33

34

Renewable energies are a promising alternative that could help to face climate change hurdles, in particular reducing greenhouse gases emissions from electricity and heat generation. In addition to their cleanliness and indigenous availability [1], they allow reducing energy dependency of countries that implement them at mid-scale. These energy sources are expected to take a leading role in the future transition from a centralized to a distributed generation scheme that is closely linked with the concept of smart grid. In fact, they are currently considered viable and even the best available solution in certain conditions for microgrid implementation [2] thanks to the easy scalability of small modular units in which the generation from these source rely on [3]. Hence, renewable energy sources (RESs) could address several issues, highlighting an improvement of security of supply, reduction of CO₂ emissions, improvement of energy systems' efficiency [4] as a result of energy transport requirements reductions. RESs would also help to develop rural areas with the creation of job opportunities and revaluation of local resources currently misused [5]. Besides, in isolated regions or communities, they could help to reduce electricity generation costs because they are currently economically competitive [6], [7].

A very promising alternative to exploit these energy sources are the hybrid renewable energy systems (HRESs), electricity generation systems that combine two or more energy sources being at least one of them a RES. These systems can be installed in different places according to the available RESs on-site. Usually, the production pattern of one source helps to counteract the production pattern of another one [8]. That is the case of solar photovoltaic (PV) power and wind power, the topics at hand in this study.

To effectively size a HRES it is required to assess the main constraints, including the load demand profile that restricts the demand of the system, as well as the wind speed and solar irradiation that restrict the supply. When performing such assessment, optimization technologies are a useful tool that support and inform decision-makers providing optimal designs according to pre-established criteria.

A thorough literature review has been performed to properly assess the current state of the art on the topic of HRES optimization. Most of the accessed HRES design and optimization papers are focused on stand-alone HRESs [2], [3], [6], [7], [9]–[15] rather than grid-connected ones because the formers show better economic feasibility than the latters as they are intended to substitute small grids fuelled with non-indigenous fossil fuels [2], [6], [7], [9]. Some of these researches rely on existent optimization software usage, such as HOMER [3], [7], [16]–[18] while others develop some optimization methodologies based on different optimization methodologies such as genetic algorithms (GA) [2], [9], [11], [12], [15], [19], [20] or dynamic programming methods [21], such as the mixed integer linear programming (MILP) [6]; whereas others only model and simulate the problem with different input values to analyze the results [10], [22], [23].

Regarding the reliability of supply, which is a critical issue of RE-based generation systems, some of the

1 systems propose storage mechanisms such as pumped hydro storage (PHS) [9], [14], [15], [17], [24], [25] or,
2 the vast majority, battery storage [6], [7], [11], [17], [20]. Conversely, other researches propose internal
3 combustion engine (ICE) such as diesel engines backup generation [18], [21] or a combination of backup
4 generation and battery storage [2], [12], [13] to counteract the stochastic variability of RE generation.
5 Another alternative is to connect the system to the grid, thus using the grid as the backup technology [23].

6 One of the key aspects of HRES optimization problems is the input data. For HRES optimization, both the
7 atmospheric data related with RE generation, that is, solar irradiation and wind speed, and the load demand
8 data are of critical importance. From the performed literature survey, it was observed that some works do not
9 use actual data sets and instead, estimate weather-related variables [6], [16], [17], [21] and/or the electricity
10 demand [7], [9], [13], [15]–[17]; whereas others use full year actual data sets for these variables [2], [3], [11],
11 [18], [20].

12 Many of the accessed papers do not include real on-time data in the analysis, a circumstance that we believe
13 that weakens the analysis due to the lack of accuracy when capturing both daily and seasonal patterns. We
14 also observed a scarcity of grid-connected HRES optimization researches and, particularly, none that
15 introduced on-time electricity sale and purchase according to actual market prices and depending on rather
16 the system has a surplus or a lack of electricity production compared with the electricity demand.

17 The aim of this article is to provide a useful and effective mechanism to better design a HRES based on
18 the usage of solar PV and wind technologies according to a minimum cost criterion while obeying to the
19 requirement of supplying the actual electricity demand of a certain location. Therefore, the methodology here
20 described is thought to provide decision-makers an optimal solution once the performance and economic
21 variables and the solar irradiation, wind and electricity demand patterns are known. The optimization is
22 performed by means of a genetic algorithm (GA).

23 It is also important to remark the willingness of this research to carry out a comprehensive cost assessment,
24 which is characterized by performing an analysis that not only includes the initial investment and the expected
25 incomes of the system, but also all the expected costs and revenues throughout lifetime of the system [26].
26 Thus, the methodology presented in this paper intends to optimize the life cycle cost focusing on all the
27 expected costs of a certain system during its lifetime as well as the expected revenues.

28 In addition to the cost treatment from a life cycle perspective, this work intends to be an original approach to
29 HRES cost optimization through the use of hourly data for both weather variables and electricity demand;
30 the utilization of genetic algorithm methodology that allows to fully control the modeling and input
31 parameters; and through the calculation at each hour of the day of cost and revenues derived from electricity
32 sale and purchase at market and retail prices respectively thus not seeing the electricity production as steady
33 profits but looking at it as a dynamic cost term, strongly linked to actual market conditions. Moreover, the
34 methodology has been tested by means of a case study with real on-site data.

35 2. SYSTEM DESCRIPTION

36 The layout of the system consists of a grid-connected PV – wind system without any kind of storage units as
37 represented in Fig.1. Therefore, the system is more flexible than a stand-alone one due to its ability to supply
38 the surplus of energy produced in low-demand and/or high-generation periods and to consume the lack of
39 energy when the demand is higher than the production of the system. In addition, a grid-connected system
40 requires a lower initial investment as a result of its fewer components because it does not require battery
41 banks that otherwise would be necessary [14] and that can mean as much as 50% of the total life cycle cost
42 of the installation [7]. The system has been designed as modularly since it allows obtaining appropriate
43 installed capacity by only increasing or decreasing the number of PV modules or wind turbines installed.

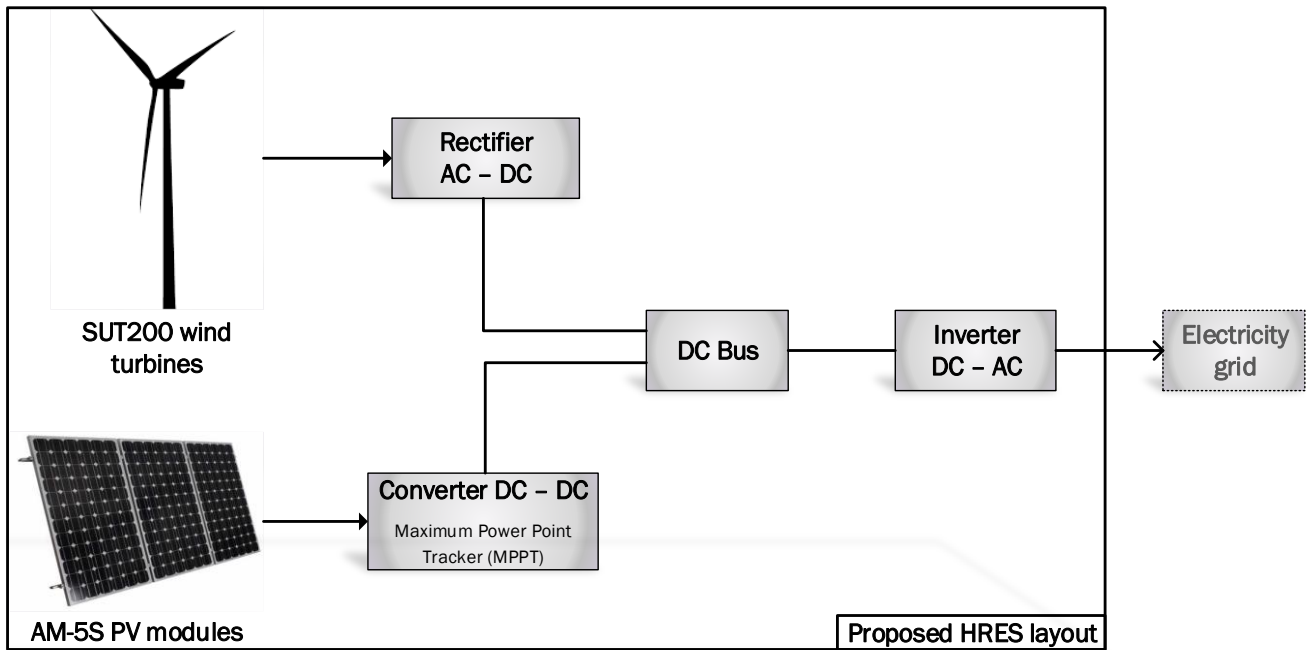

Fig. 1. Proposed HRES layout

The chosen components are the AmeriSolar AS-5M PV module with a nominal power of 210_W and 1.277 m² per module [27] and the SUT200 wind turbine with a nominal power of 200 kW [28]. The variables used to optimize the system are the area covered by the PV modules, which is proportional to the number of PV modules, and the number of wind turbines installed.

The design condition of net annual balance has been selected as the constraint for supply – demand match. By annual net balance it is understood a design constraint that establishes that the total amount of electricity generated by the HRES matches the total demand of the location under study throughout the year, but not necessarily hour by hour, but in global terms. Therefore, the lack of electricity generation at those hours with low availability of solar and wind resources can be counteracted by the excess of electricity production at other times when the system can produce more electricity that is being demanded.

Another important aspect is the system scale. The methodology described here has been designed to be usable in a range of different cases with different scales by only changing the input variables according to the scale of the problem and using the weather variables and demand of the particular site under study.

3. METHODOLOGY DESCRIPTION

The methodology applied is divided in three steps: sample selection, input data gathering and algorithm design and test. These steps are described below.

3.1 Sample selection

With the purpose of testing the designed methodology, a particular location has been chosen as a case study sample. Such location is Santa Coloma de Queralt, a rural township in central Catalonia, a region characterized by having a Mediterranean climate with moderately high solar irradiation throughout the year and also by having a medium wind potential as there are no big orographic obstacles. The system sizing has been done for the entire township with 1271 residential dwellings [29]. The demand data were provided by the local utility company [30]. It is worth noting that these households have an annual electricity consumption close to the average household electricity consumption for the Mediterranean region [31].

In addition, Spain has electricity prices close to the Euro area electricity average price [32] so the results derived from this case study will be significantly representative for any other European country in the

1 Mediterranean area, for instance Greece, France or Italy. Despite the applicability of the results of the
 2 proposed case study to similar climate regions, the methodology is designed to be as universal as possible
 3 allowing to be applied wherever is desired provided that the location-dependent input variables, that is solar
 4 irradiation, wind speed and electricity demand hourly patterns, are known.
 5

6 3.2 Input data

7 In order to ensure the reliability of the results provided by the algorithm, all the data have been gathered from
 8 several trustworthy sources. These data are classified into three groups, i.e. stochastic variables as weather-
 9 related variables and electricity demand, equipment costs and financial variables, and equipment efficiency and
 10 performance data.

11 Stochastic variables

12 The stochastic variables relevant for this model are the weather-related variables required to model the
 13 production of renewable energy as well as the electricity demand that is sought to be supplied. The selected
 14 accuracy is one datum per hour during an entire year, which allows capturing the seasonal and daily
 15 variability of these magnitudes without forcing the algorithm to manage a huge amount of data. The selected
 16 period of analysis is year 2011 because that is the last year with all the data readily available from the accessed
 17 sources.

18 Table I lists the hourly series of these variables, and Figs. 2 and 3 show the patterns of them for a random
 19 labor day, April 19th.

20
 21 TABLE I
 22 HOURLY SERIES OF STOCHASTIC VARIABLES

Data	Value	Source
Solar irradiation (W/m ²)	Vector of 8760 points corresponding to 24 hours per 365 days	[33]
Wind speed at 6 m (m/s)	Vector of 8760 points corresponding to 24 hours per 365 days	[33]
Electricity demand profile (kWh)	Vector of 8760 points corresponding to 24 hours per 365 days	[30]

23 Regarding to the wind speed data, the measured data corresponds to an anemometer placed at 6 meters of
 24 altitude. The chosen wind turbine can be installed with a layout of 30, 36 and 40 meters of rotor altitude [28]
 25 so an extrapolation of wind speed has been performed using the power law equation that is a robust method
 26 to model the boundary layer [34]:
 27

$$V_{H,t} = V_{H_0,t} (H/H_0)^{1/7} \quad (1)$$

28 where $V_{H,t}$ and $V_{H_0,t}$ are, respectively, the estimated wind speed at height H and the measured one at height
 29 $H_0 = 6 \text{ m}$ at time interval t .

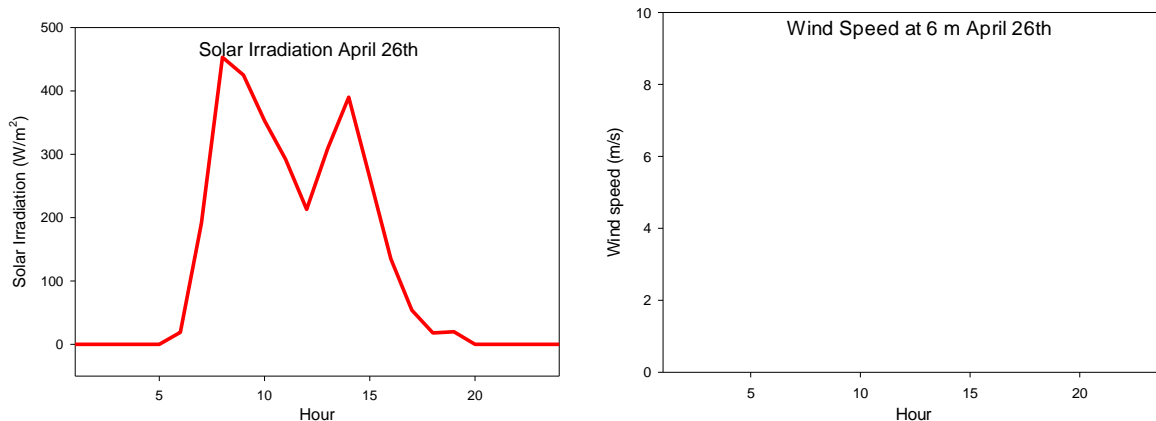

30 Fig. 2. Solar irradiation (W/m²) and wind speed (m/s) for January April 26th
 31

1

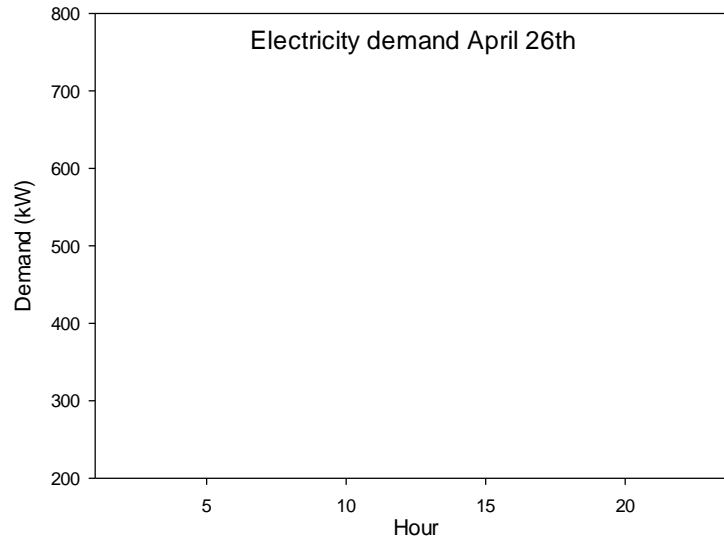

Fig. 3. Electricity demand for April 26th, 2011 in the location under study

Cost and financial variables

The cost variables to be considered range from the equipment acquisition costs to the operation and maintenance (O&M) expenditures, including the equipment replacement costs whenever required throughout the lifetime of the system.

There are also some financial variables that are important to be considered to effectively perform the cost optimization under the perspective of the lifecycle analysis. For instance, the lifetime of the entire system and the different components of it, whenever different, must be included to account for inflation of electricity and obsolete equipment selling prices. The interest rate must also be included because it is necessary to discount all the future costs and revenues as if they took place at the moment of initial investment, according to the Net Present Value metric.

The values of all these variables are listed in Table II.

TABLE II
EFFICIENCY AND PERFORMANCE VARIABLES

Data	Variable name	Value	Source
System lifetime	N	25 years	[35]–[37]
Wind turbine lifetime	Y_{wt}	20 years	[37]
Solar PV DC – DC converter lifetime	Y_{inv}	15 years	[20], [37]
Interest rate	IR	3.5%	[38]
Spain's Value Added Tax (VAT) rate	TR	21%	[39]
General inflation rate	g	3%	[37]
Electricity selling price inflation rate	$g_{electricity}$	3%	[37]
Wind turbines selling price inflation rate	g_{wt}	-5%	[37]
Converter selling price inflation rate	g_{inv}	-5%	[37]
Cost reduction limit due to technological maturity for wind turbines	L_{g_wt}	-25%	[37]
Cost reduction limit due to technological maturity for converters	L_{g_inv}	-25%	[37]
PV capital cost	C_{PV}	3800 \$/kW	[40]
Wind capital cost	C_{WT}	2700 \$/kW	[41]
Converter capital cost	C_{INV}	250 \$/kW _{PV}	[37]
PV fixed O&M costs	$C_{PV\ fixed\ O\&M}$	32.64 \$/kW	[42]
Wind fixed O&M costs	$C_{WT\ fixed\ O\&M}$	32.15 \$/kW	[42]
PV variable O&M costs	$C_{PV\ var\ O\&M}$	0 \$/kW	[42]
Wind variable O&M costs	$C_{WT\ var\ O\&M}$	0.01475 \$/kW	[42]

2
3
4
5
6
7
8
9
10
11
12
13
14
15
16
17

Electricity market price	C_{pool}	Vector of 8760 points; 24 hours per 365 days	[43]
Electricity retail price	C_{electr}	Peak – 0.101406 €/kWh Flat – 0.078289 €/kWh Off-peak – 0.052683 €/kWh	[44]
Time periods		Peak: 17-23 winter/10-16 summer Flat: 8-17, 23-24 winter /8-10,16-24 summer Off-peak: 0-8 winter time / summer time	[45]

According to [40], PV system costs decrease exponentially as the size of installation increases, reaching an average value of \$3.8 per Watt for utility-scale installations that are those relevant for the scale of the proposed case study. The values provided account for the cost of all the components of an installed system: PV modules, converter, installation materials, labor costs, supply chain and even land acquisition and taxes, commissioning and permitting costs. For residential or commercial scale equipment this value should be changed to take into account the higher costs of the technology.

Regarding the wind power systems price, the data given in [41] also show an exponential decrease in price with increasing project size. In this case, the entire cost of the system is also provided.

Furthermore, the electricity retail prices [44] have been introduced only taking into account the price of the energy consumed, i.e. the cost of the kWh, and considering the different prices at different time discrimination periods that the electrical bill has. The fixed costs derived from the contract like the cost of the power contracted, are not introduced as the system is designed as grid-connected so they will be paid regardless of the consumption that is what is expected to be reduced. For the market price of electricity, the data of a whole year has been retrieved from the Iberian market operator OMIE [43], which provides the clearing price in the pool of electricity with hourly accuracy that is the time period at which the auctions take place. With these two datasets, it is possible to account for the benefits of selling electricity and costs of purchasing it according to the positive production (surplus) or negative production (lack) of electricity at each hour of the day.

These prices are considered to suffer an annual inflation of 3%, a conservative value according to last years' price change that doubled that value [46].

Efficiency and performance variables

This set of data includes all the variables required to implement the performance calculation into the model. That includes all the efficiencies of a solar PV installation and a wind turbine installation. For solar PV power, these data include the module efficiency itself but also the wiring, converter and de-rating efficiencies among others [40]; whereas for wind power that is acquired in the form of the characteristic curve of the wind turbine provided by the manufacturer that includes all the efficiencies of the entire wind turbine [41].

Table III shows the values used in the algorithm for all the variables that take a fixed value.

TABLE III
EFFICIENCY AND PERFORMANCE VARIABLES

Data	Value	Source
Module reference efficiency	15.0%	[27]
Model nameplate de-rate	95.0%	[47]
Converter efficiency	92.0%	[47]
Module mismatch factor	98.0%	[47]
Connections efficiency	99.5%	[47]
DC wiring losses factor	98.0%	[47]
AC wiring losses factor	99.0%	[47]
Soiling de-rate factor	95.0%	[47]
System availability O&M	98.0%	[47]

In addition to such information, it is also important to introduce the PV power warranted by the manufacturer curve [27], which diminishes over time as a result of aging (see Fig. 4) and the wind power characteristic curve [28] (see Fig. 5) that shows the output of the wind turbine, including the wiring, generator, transformer and power and control cabinet efficiencies.

The warranted power refers to the module reference efficiency, so the manufacturer warrants 97% of the reference efficiency for the first two years and then the warranted power experiences a linear decline until reaching 80% of the reference efficiency by the 30th year of module usage.

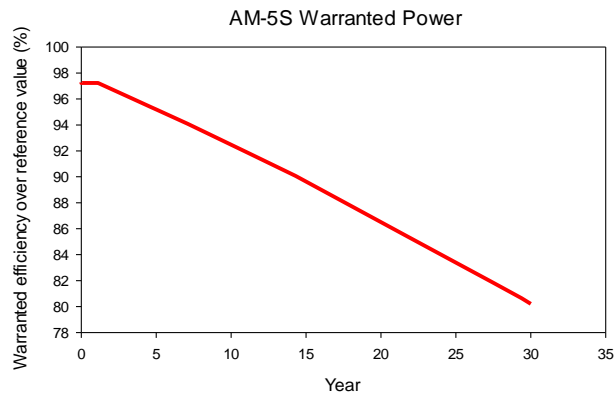

Fig. 4. Warranted power (%) over lifetime of AS-5M PV module

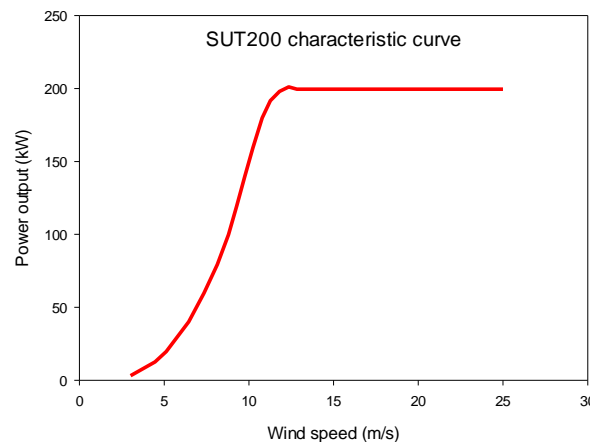

Fig. 5. SUT200 characteristic curve, representing output power (kW) over wind speed (m/s)

3.3 Algorithm description

For HRESs optimization, as a result of the inherently non-linear variables found in this kind of problems involving stochastic variables such as weather patterns [48] or electricity demand patterns, the most preferred methodologies are GAs and particle swarm optimization (PSO) algorithms [19], both heuristic approaches. Among the advantages of iterative algorithms highlight their low computational requirements that allow them to obtain the desired solutions without requiring huge amounts of computational resources [49]. In particular, GAs have been identified and used as one of the best alternatives for those cases where non-linear systems are involved as HRES cost optimization problems are [50] even in cases with only few variables involved because this method is very good attaining optimal solutions with non-linear relationships between variables [9].

The parameters that are usually analyzed for HRES optimization include not only the cost, which is the topic at hand, but also the lifetime environmental impact of the system, the reliability of supply or a combination

of two or more of these parameters [35], [49]–[51], obtaining in such multi-objective case a set of possible solutions called Pareto front.

The software used to run the optimization procedure is MATLAB R2013b, in which GAs are already implemented in the “Optimization Toolbox”.

Variables

The variables chosen to represent the different potential alternative systems are the area covered by PV modules $pvArea$, which is proportional to the number of PV modules $pvNumber$, and the number of wind turbines $wtNumber$. With these variables, the GA will treat the objective function as dependent of the system sizing and will provide as outputs the minimum Net Present Value and the values of both variables that lead to an optimal HRES sizing with a minimum NPV .

Wind turbine number variable is treated as an integer by the optimization algorithm. Conversely, the PV area allows using decimal values thus reducing the computational requirements to run the GA. That is why the area is selected as the variable rather than the number of PV modules.

Objective (fitness) function

The parameter that is sought to optimize in the present work is the cost of the system. Considering that lifecycle perspective is currently gaining importance in HRES’ optimization methodologies [20], the lifecycle cost has been chosen as the metric to optimize. To do so, the chosen objective function is the Net Present Value (NPV) cost metric that is calculated by adding the discounted present values of all lifetime incomes and subtracting the discounted present costs along lifetime of the system, i.e. considering the expenses and revenues 25 years ahead. Therefore, this cost metric is accounting for the future cash-flows’ present value by converting them to the value of money at the time of investment after applying inflation and discount rate to all of them. Hence, the system lifetime costs can be analyzed discounting external effects like the financial volatility or oscillations inherent to the free market economy that affect the value of money. To appropriately compute all the costs throughout the entire lifetime of the system, the initial investment, operation and maintenance, equipment replacement and electricity purchase costs have been taken into account, similarly as done in [20]. On the other hand, the benefits from selling the electricity to the grid and the profit from equipment sale at the end of the lifetime have been considered on the benefits side:

$$NPV = C_{investment} + NPV_{O\&M} + NPV_{repl} - NPV_{electricity} - NPV_{endLife} = f(pvArea, wtNumber) \quad (2)$$

(2) being the fitness function. In the following paragraphs, the five terms in (2) are detailed.

The initial investment cost refers to the initial expense required for equipment purchase. It has been implemented as a function of the number of modules and the number of wind turbines installed:

$$C_{investment} = C_{PV} \cdot pvNumber \cdot P_{module} + C_{WT} \cdot wtNumber \cdot P_{turbine} \quad (3)$$

where C_{PV} is the capital cost of PV panels in \$/kW, P_{module} is the nominal power of each module; C_{WT} is the capital cost of wind turbines in \$/kW and $P_{turbine}$ is the wind turbine nominal power. As the input variable is $pvArea$, the number of PV modules is expressed as follows:

$$pvNumber = pvArea / panelArea$$

where $pvArea$ is the independent variable and $panelArea$ is the area covered by a single PV module, in the case study 1.277 m².

The discounted operation and maintenance costs are calculated considering the annual inflation rate [37]:

$$NPV_{O\&M} = \sum_{i=1}^N C_{O\&M_k} \frac{(1+g)^i}{(1+IR)^i} \quad (4)$$

where $C_{O\&M_k}$ refers to the cost of operation and maintenance of component k , g is the general inflation rate, IR is the interest rate and N is the system lifetime.

The discounted present costs of equipment replacement are also calculated considering the annual inflation

1 rate [37]:

$$NPV_{repl_k} = \sum_{i=1}^{N_{firstrepl_k}} C_k \frac{(1+g_k)^{i \cdot N_k}}{(1+IR)^{i \cdot N_k}} + \sum_{i=N_{firstrepl}+1}^{N_{repl_k}} C_k \frac{(1+g_k)^{Y_k} (1+g)^{i \cdot N_k - Y_k}}{(1+IR)^{i \cdot N_k}} \quad (5)$$

2 where C_k is the acquisition cost of component k , g_k is the expected inflation rate of the acquisition cost of
 3 component k and Y_k is the lifetime of such component. N_{repl_k} and $N_{firstrepl_k}$ are the total number of
 4 replacements during system lifetime and during the years that the price of the component is changing at g_k
 5 inflation rate, respectively, and are calculated as follows [37]:

$$N_{repl_k} = int \left[\frac{N}{Y_k} \right] \quad (6)$$

$$N_{firstrepl_k} = int \left[\frac{Y_{g_k}}{Y_k} \right] \quad (7)$$

6 where Y_{g_k} is the number of years required for technology k to reach the technological maturity with a cost
 7 reduction of L_{g_k} [37]:

$$Y_{g_k} = \frac{\log(1+L_{g_k})}{\log(1+g_k)} \quad (8)$$

8 The PV – wind hybrid system that is being studied is considered to have a lifetime of 25 years which is the
 9 lifetime of the component that lasts more, the PV module. Therefore, the costs of equipment replacement
 10 only account for wind turbine and solar PV converter replacement, as the wind turbine has a lifetime of 20
 11 years and solar PV converter has a lifetime of 15 years (see Table II).

12 The cost of electricity purchase and the benefits derived from electricity sale are computed together in the
 13 algorithm. To effectively perform that, the hourly net power production is calculated by adding up the PV
 14 power production (NPP) and the wind power production and subtracting the electricity demand for each
 15 hour:

$$NPP = P_{PV} + P_{WT} - demand \quad (9)$$

16 where P_{PV} and P_{WT} are the PV and wind power produced at each hour of the 365 days of a year and $demand$
 17 is the electricity demand of the location under study. This point-to-point comparison of production and
 18 demand allows implementing the annual net balance design condition as a forced zero sum of all the 8760
 19 points. It also allows calculating the exact benefit or cost of selling or purchasing electricity according to the
 20 hourly market and retail prices.

21 If the sign of (9) is positive, more power is produced than demanded so the electricity is sold at the market
 22 price. Conversely, if the sign of the sum is negative, the system is producing less power than demanded so
 23 the lack has to be purchased at the electricity retail price. This entire process is introduced in the algorithm
 24 considering the electricity selling price inflation $g_{electricity}$ [37]. Therefore, for negative net power
 25 production, the net present cost of electricity purchase is:

$$NPV_{electricity} = \sum_{i=1}^N \sum_{j=1}^{8760} C_{electr_j} \cdot NPP_j \cdot \frac{(1+g_{electricity})^i}{(1+IR)^i} \quad (10)$$

26 And for positive net power production, the discounted present incomes from the selling of electricity are:

$$NPV_{electricity} = \sum_{i=1}^N \sum_{j=1}^{8760} C_{pool_j} \cdot NPP_j \cdot \frac{(1+g_{electricity})^i}{(1+IR)^i} \quad (11)$$

27 It should be pointed out that in the first case, $NPP < 0$ or lack of electricity, the $NPV_{electricity}$ will take
 28 negative values whereas in the second case, $NPP > 0$ or surplus of electricity, the $NPV_{electricity}$ will take

1 positive values. As a result, this term of $NPV_{electricity}$ is computed in the benefits side as previously
 2 mentioned.

3 The last term of the NPV calculation is the discounted present value of incomes from the sale of equipment
 4 at the end of system lifetime [37], and is also computed in the benefits side of the NPV calculation.

$$NPV_{endLife_k} = C_k \left[1 - \frac{N_{repl_k} Y_k}{N} \right] \left(\frac{(1 + g_k)^{Y_{g,k}} (1 + g)^{N - Y_{g,k}}}{(1 + IR)^N} \right) \quad (12)$$

5 The entire methodology of the proposed grid-connected HRES power balance approach is detailed in Fig. 6.

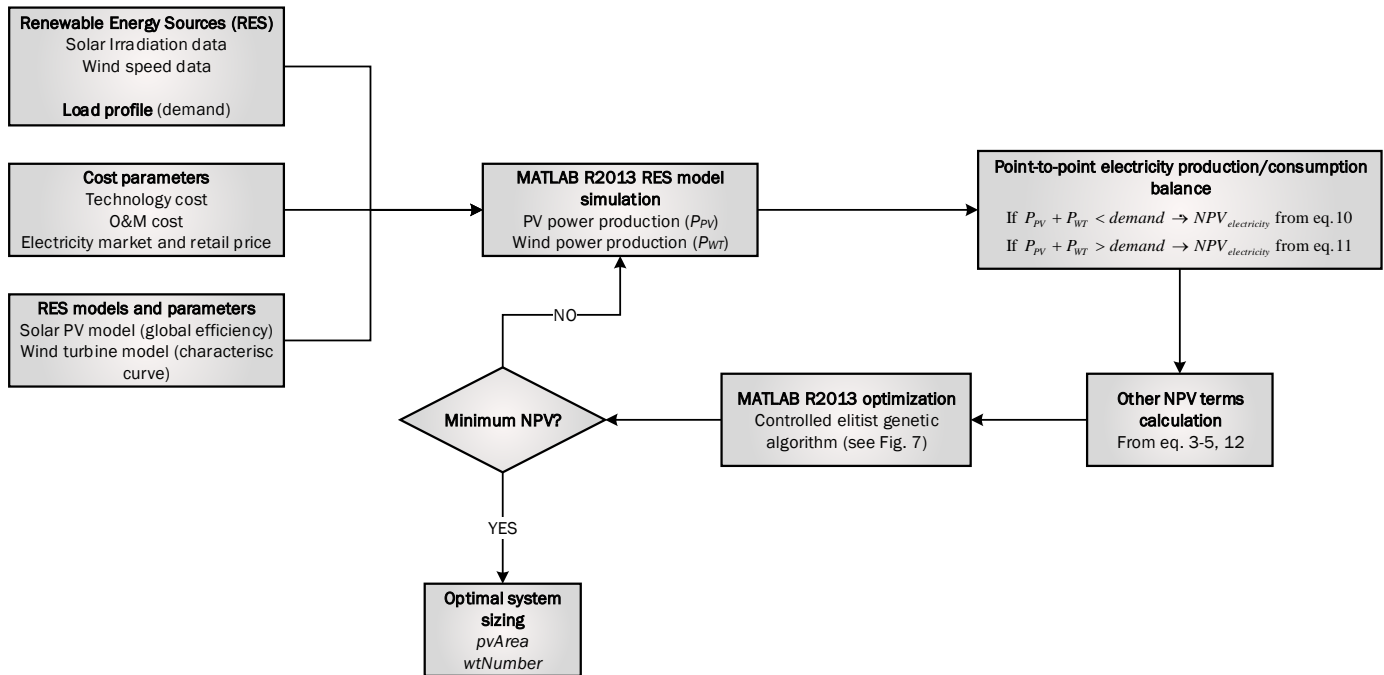

6
 7 Fig. 6. Proposed HRES cost optimization approach
 8

9 Optimization process

10 Once the objective function is properly defined and all the input variables introduced, the optimization
 11 algorithm can be run. From all the available alternatives, the GA optimization methodology has been selected
 12 for its easiness to tackle multiple solution problems using a random population of potential solutions and
 13 evolutionary methods to narrow down the possibilities according to the fitness of each possible solution until
 14 finding the optimum. The methodology starts with the generation of a random population with a size of:

$$PopulationSize = \max(\min(10 \cdot numberOfVars, 100), 40) \quad (13)$$

15 From this population the best individuals are selected according to the fitness function that is sought to
 16 optimize. The individuals are scaled by a “Rank” criterion meaning that the top individuals are selected; in
 17 this case, 5% is selected:

$$EliteCount = 0.05 \cdot \max(\min(10 \cdot numberOfVars, 100), 40) \quad (14)$$

18 Once they are selected, a new generation of “offspring” individuals is created crossover that is the creation
 19 of a new individual or child from two existent individuals or parents, of existent specimens. The crossover
 20 fraction is set to 80% and the method to “Scattered”. Mutation does not occur because this process is ignored
 21 with one or more integer variables. Migration is another process that allows movement of individuals within
 22 the space of solutions. In this case, 20% of individuals migrate in “forward” direction every 20 generations.
 23 From the old set of individuals, the “least-fit” individuals are rejected and replaced by the new generation
 24 and this process is repeated many times until the minimum value of the fitness function is found. The stopping
 25 criterion is the condition of having an average change in the fitness function value below the function
 26 tolerance, in this case $1 \cdot 10^{-6}$ once the stall generation, in this case 50, is reached.

1 Input variables upper and lower bounds are used to introduce restrictions in the potential solutions, so the
 2 lower bounds are 0 m² of area covered by PV modules and 0 wind turbines, the case of no system installed.
 3 The upper bounds set are the maximum allowable installed capacity of each renewable energy source. They
 4 have been assumed to be higher enough to not introduce any limitation but they could be set to a certain value
 5 if there were limitations in terms of maximum initial investment or available land useful to install the
 6 equipment, for instance.

7 Fig. 7 schematizes the optimization process by means of GA and specifies the selected parameters:

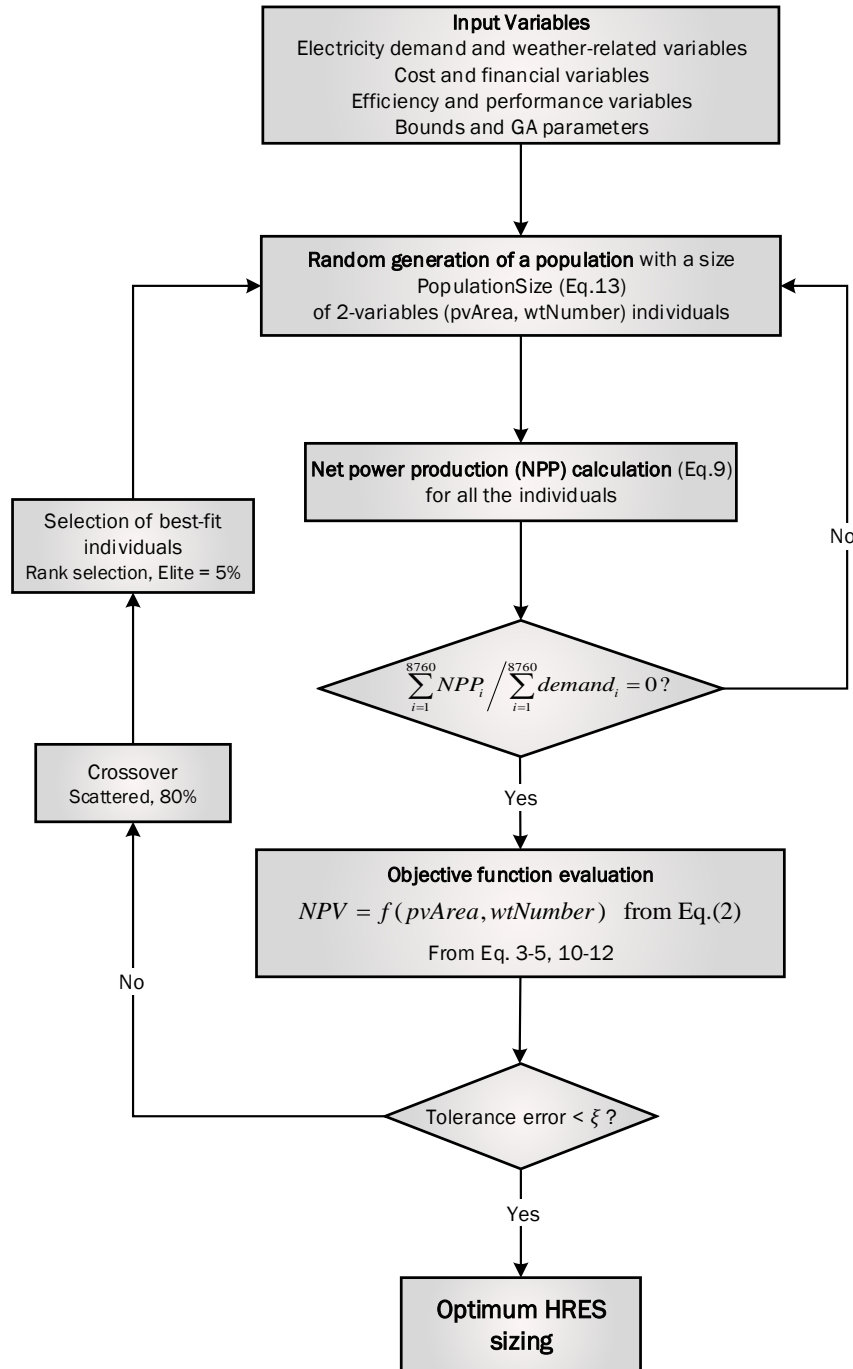

8
 9 Fig. 7. Optimization model and parameters

10

11

4. RESULTS

12 With aim to contextualize the values obtained, all the simulated cases are compared with the no-HRES case,

1 i.e. the case of a system with no solar nor wind renewable sources. This is a reduction of the general case
 2 used to estimate the cost of supplying the demand according to the actual situation in which the electricity is
 3 purchased from the local utility at the market retail price.

5 4.1 No-HRES scenario

6 The no-HRES case is obtained by running the algorithm with zero solar PV power and zero wind power
 7 production.

8 The total electricity demand in one year, obtained from the data in [30], equals 4657.97 MWh. The cost of
 9 supplying this demand during the 25 years that a HRES would last, and considering the actual demand at
 10 each hour is purchased at the price established in the tariff with hourly discrimination is:

$$11 \quad \text{no - HRES NPV} = \$2.3446 \cdot 10^7 = \$23.446\text{M}$$

12 That would be the total cost of supplying the present demand considering that electricity price suffers an
 13 annual inflation of 3% (see Table II).

15 4.2 HRES base case scenario

16 The base-case is the case simulated using all the variables as previously defined in Tables I, II and III and
 17 Figs. 3 and 4. The wind data used have been extrapolated to 35m of rotor height, found at the middle between
 18 30 and 40 m, the minimum and maximum values provided by the manufacturer [28]. The optimization
 19 procedure provides the following result:

$$20 \quad \text{base - case NPV} = \$1.5353 \cdot 10^7 = \$15.353\text{M}$$

21 This result is reached with a system with 621.61m² of PV installation and 18 wind turbines, equivalent to
 22 102.22 kW of PV power and 3.6 MW of wind power, a HRES that would require an initial investment of
 23 $\$1.0108 \cdot 10^7 = \10.108M .

24 For comparison purposes, the evolution of NPV of No-HRES and base case scenarios during the system
 25 lifetime are shown in Fig. 7.

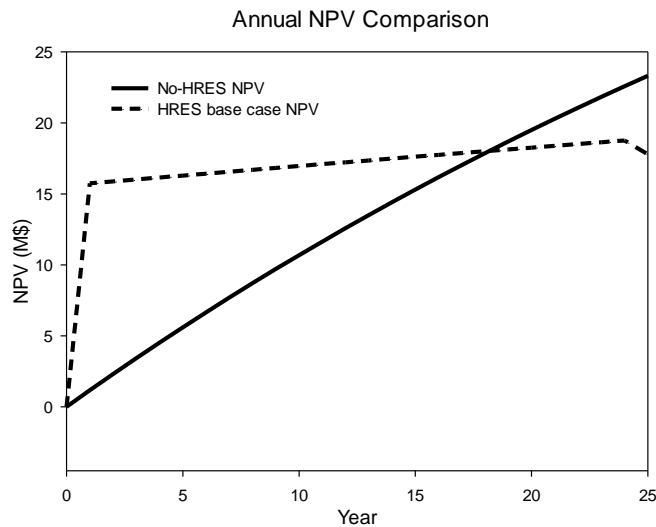

26 Fig. 7. Comparison of NPV evolution throughout 25 years of system lifetime for No-HRES and HRES base case scenarios

29 4.3 Sensitivity analysis

30 The sensitivity analysis is performed introducing percent variations in the most relevant parameters of the
 31 system to observe how these variations vary the output of the system.

32 The variables chosen to be studied in this sensitivity analysis are: PV technology capital cost, wind
 33 technology capital cost, electricity price, general inflation rate, module and wind turbine reference

1 efficiencies and interest rate. The change introduced in the values of these variables induces variations in the
 2 result of different magnitude. The results are shown in Table IV.

3 TABLE IV
 4 SENSITIVITY ANALYSIS

Variable	Variation	NPV change
PV capital cost	+10%	+0.261%
Wind capital cost	+10%	+9.381%
Electricity price	+10%	+0.000%
General inflation rate (g)	+10%	+1.238%
Interest rate	+10%	-2.002%
Module reference efficiency	+10%	-0.261%
Wind turbine reference efficiency	+10%	-8.599%

5 DISCUSSION

7 The Net Present Value of the HRES base case is \$15.535, 65.26% of the no-HRES NPV. However, the
 8 system requires an initial investment of \$10.108M. This significant upfront investment required is the main
 9 hurdle to be overcome by renewable energy technologies. However, when the evolution of NPV during
 10 system lifetime for both base case and no-HRES scenarios are compared, it emerges that the installation of a
 11 HRES implies higher accumulated costs during first years, a tendency that is inverted approximately after
 12 two thirds of system life time. In particular, with the proposed case study the system would imply less
 13 accumulated costs from 18th year onwards (see Fig. 7). Therefore, even though the required investment is a
 14 significant amount that is never paid off, the system proves to be worthwhile once the current situation costs
 15 are taken into consideration. Besides, the NPV evolution throughout system lifetime also shows that policies
 16 that would improve RES profitability could act either on the slope of the curve or in the huge jump that is
 17 observed in the first year. To influence on the former, one could subsidize the renewable electricity sale, for
 18 instance introducing a feed-in tariff that would increase the electricity selling price and thus invert the slope
 19 of the curve; whereas to influence on the latter, one should subsidize the installation of renewable energy
 20 systems. The first solution has been adopted in countries like Germany, Spain or Australia, whereas the
 21 second is the alternative proposed in some US States like California.

22 From the sensitivity analysis results, it is shown that the most significant parameter analyzed is the wind
 23 capital cost. That is because the optimal sizing found by the algorithm consists on a 3.6 MW wind installation
 24 for the 0.1 MW of solar PV power, so changes in the cost of the component that represents more than 95%
 25 of the total installation are expected to affect more the final NPV than changes in the cost of the component
 26 that represents less than 5% of installation size.

27 Furthermore, it is shown that the electricity price does not significantly affect the result, so the installation is
 28 expected to have the reported profitability regardless of the inflation of electricity price. This effect is caused
 29 by the low impact of electricity purchasing prices on the system as it is based on the reduction of electricity
 30 consumption from the grid. Conversely, the inflation in the retail electricity prices would affect the break-
 31 even point as the no-HRES scenario would see its costs surge, making the installation of the HRES system
 32 more worthwhile compared with the business-as-usual alternative.

33 The last analyzed variable is the interest rate. Increases in this variable result in decreases in the NPV as they
 34 mean more money value discount in future years. That is why in the NPV definition itself the interest rate is
 35 dividing several terms (see (4), (5), (10)-(12)). This behavior shows the effect of time value of money, which
 36 means that a certain amount of money is worth more at present time than in the future, and that this discounted
 37 present value is lower as higher is the discount rate. The chosen value in the base case of 3.5% is a reasonable
 38 approach considering the current interest rates for loans to non-financial corporations in Spain that averaged
 39 3.5% in the last 10 years [38].

1 It is also worth mentioning that the system sizing does not suffer changes with the first five cases, PV and
 2 wind capital cost, electricity price, general inflation rate and interest rate; but with the other two cases, PV
 3 module and wind turbine efficiency improvements, the system sizing is changed. On the one hand, with 10%
 4 improvement in the PV module reference efficiency, the new HRES consists of 18 wind turbines and
 5 565.13m² of PV installation, being the total installed capacity the same as in the base case scenario but with
 6 10% less land usage for the PV installation. On the other hand, with 10% improvement in the wind turbine
 7 reference efficiency, the new HRES consists of 17 wind turbines and PV installation reduced to a marginal
 8 size, the total installed capacity remaining again unchanged at roughly 3.7MW but with different share of
 9 each RE technology.
 10

11 6 CONCLUSIONS

12 An optimization algorithm that calculates the optimum sizing for a grid-connected HRES according to a
 13 given electricity demand has been developed and tested through a case study. The HRES combines solar PV
 14 and wind power technologies at the most appropriate scales to supply the existent demand with a minimum
 15 life cycle cost that is measured using the Net Present Value, an economic metric that discounts the future
 16 costs and revenues at the time of investment. The designed optimization algorithm performs an analysis with
 17 one hour accuracy in order to capture the daily and seasonal patterns of both weather-dependent renewable
 18 energies and electricity demand. Moreover, it performs a meticulous calculation of the renewable electricity
 19 generation patterns and thus the profits and revenues derived from it, not only because of the different amount
 20 of energy produced at each hour but also because of the consideration of the different market and retail prices
 21 at each hour of the day.

22 A sensitivity analysis has been performed through the simulation of slight variations of a base case that served
 23 to understand the behavior of the results given by the algorithm in front of changes in the most important
 24 input variables. Such analysis also includes a comparison with the no-HRES scenario that helps
 25 understanding how significant are the cost savings compared with the present situation costs.

26 Another aspect to highlight is that the algorithm responds well to positive and negative changes in the
 27 analyzed variables. For instance, the NPV obtained from the algorithm increases when cost variables
 28 increase, whereas decreases when efficiency of RE technologies improves. Again, wind turbine efficiency
 29 improvements have greater impacts on the result than PV panel efficiency improvements due to the greater
 30 importance of wind installation in the case under study.

31 The results, therefore, show that in the location under study wind power is the renewable resource with greater
 32 impact but that it is well complemented by solar resource. Such HRES also proves its appropriateness to
 33 replace the present scenario in which electricity consumption is only supplied by the electrical grid, with
 34 potential savings amounting up to 40% of present cost structure throughout the next 25 years.
 35

36 REFERENCES

- 37 [1] B. Buragohain, P. Mahanta, and V. S. Moholkar, "Biomass gasification for decentralized power
 38 generation: The Indian perspective," *Renew. Sustain. Energy Rev.*, vol. 14, no. 1, pp. 73–92, 2010.
- 39 [2] B. Zhao, X. Zhang, P. Li, K. Wang, M. Xue, and C. Wang, "Optimal sizing, operating strategy and
 40 operational experience of a stand-alone microgrid on Dongfushan Island," *Appl. Energy*, vol. 113,
 41 pp. 1656–1666, Jan. 2014.

- 1 [3] L. Montuori, M. Alcázar-Ortega, C. Álvarez-Bel, and A. Domijan, "Integration of renewable energy
2 in microgrids coordinated with demand response resources: Economic evaluation of a biomass
3 gasification plant by Homer Simulator," *Appl. Energy*, vol. 132, pp. 15–22, Nov. 2014.
- 4 [4] V. Kuhn, J. Klemeš, and I. Bulatov, "MicroCHP: Overview of selected technologies, products and
5 field test results," *Appl. Therm. Eng.*, vol. 28, no. 16, pp. 2039–2048, 2008.
- 6 [5] D. Silva Herran and T. Nakata, "Design of decentralized energy systems for rural electrification in
7 developing countries considering regional disparity," *Appl. Energy*, vol. 91, no. 1, pp. 130–145, Mar.
8 2012.
- 9 [6] M. Ranaboldo, B. D. Lega, D. V. Ferrenbach, L. Ferrer-Martí, R. P. Moreno, and A. García-Villoria,
10 "Renewable energy projects to electrify rural communities in Cape Verde," *Appl. Energy*, vol. 118,
11 pp. 280–291, Apr. 2014.
- 12 [7] T. Ma, H. Yang, and L. Lu, "A feasibility study of a stand-alone hybrid solar–wind–battery system
13 for a remote island," *Appl. Energy*, vol. 121, pp. 149–158, May 2014.
- 14 [8] M. K. Deshmukh and S. S. Deshmukh, "Modeling of hybrid renewable energy systems," *Renew.
15 Sustain. Energy Rev.*, vol. 12, no. 1, pp. 235–249, 2008.
- 16 [9] T. Ma, H. Yang, L. Lu, and J. Peng, "Pumped storage-based standalone photovoltaic power
17 generation system: Modeling and techno-economic optimization," *Appl. Energy*, Jun. 2014.
- 18 [10] F. Calise, A. Cipollina, M. Dentice d'Accadia, and A. Piacentino, "A novel renewable
19 polygeneration system for a small Mediterranean volcanic island for the combined production of
20 energy and water: Dynamic simulation and economic assessment," *Appl. Energy*, vol. 135, pp. 675–
21 693, Dec. 2014.
- 22 [11] H.-C. Chen, "Optimum capacity determination of stand-alone hybrid generation system considering
23 cost and reliability," *Appl. Energy*, vol. 103, pp. 155–164, Mar. 2013.
- 24 [12] A. T. D. Perera, R. A. Attalage, K. K. C. K. Perera, and V. P. C. Dassanayake, "A hybrid tool to
25 combine multi-objective optimization and multi-criterion decision making in designing standalone
26 hybrid energy systems," *Appl. Energy*, vol. 107, pp. 412–425, Jul. 2013.
- 27 [13] A. T. D. Perera, R. A. Attalage, K. K. C. K. Perera, and V. P. C. Dassanayake, "Designing
28 standalone hybrid energy systems minimizing initial investment, life cycle cost and pollutant
29 emission," *Energy*, vol. 54, pp. 220–230, Jun. 2013.
- 30 [14] B. Bhandari, K.-T. Lee, C. S. Lee, C.-K. Song, R. K. Maskey, and S.-H. Ahn, "A novel off-grid
31 hybrid power system comprised of solar photovoltaic, wind, and hydro energy sources," *Appl.
32 Energy*, vol. 133, pp. 236–242, Nov. 2014.
- 33 [15] T. Ma, H. Yang, L. Lu, and J. Peng, "Optimal design of an autonomous solar–wind–pumped storage
34 power supply system," *Appl. Energy*, Dec. 2014.
- 35 [16] G. Bekele and G. Tadesse, "Feasibility study of small Hydro/PV/Wind hybrid system for off-grid
36 rural electrification in Ethiopia," *Appl. Energy*, vol. 97, no. 0, pp. 5–15, 2012.

- 1 [17] G. Bekele and B. Palm, “Feasibility study for a standalone solar–wind-based hybrid energy system
2 for application in Ethiopia,” *Appl. Energy*, vol. 87, no. 2, pp. 487–495, 2010.
- 3 [18] S. Rehman, M. Mahbub Alam, J. P. Meyer, and L. M. Al-Hadhrami, “Feasibility study of a wind–
4 pv–diesel hybrid power system for a village,” *Renew. Energy*, vol. 38, no. 1, pp. 258–268, 2012.
- 5 [19] M. Fadaee and M. A. M. Radzi, “Multi-objective optimization of a stand-alone hybrid renewable
6 energy system by using evolutionary algorithms: A review,” *Renew. Sustain. Energy Rev.*, vol. 16,
7 no. 5, pp. 3364–3369, 2012.
- 8 [20] D. Abbes, A. Martinez, and G. Champenois, “Life cycle cost, embodied energy and loss of power
9 supply probability for the optimal design of hybrid power systems,” *Math. Comput. Simul.*, vol. 98,
10 pp. 46–62, Apr. 2014.
- 11 [21] Y. Hu and P. Solana, “Optimization of a hybrid diesel-wind generation plant with operational
12 options,” *Renew. Energy*, vol. 51, pp. 364–372, Mar. 2013.
- 13 [22] J. K. Kaldellis, K. A. Kavadias, and A. E. Filios, “A new computational algorithm for the calculation
14 of maximum wind energy penetration in autonomous electrical generation systems,” *Appl. Energy*,
15 vol. 86, no. 7–8, pp. 1011–1023, Jul. 2009.
- 16 [23] M. Alsayed, M. Cacciato, G. Scarcella, and G. Scelba, “Multicriteria Optimal Sizing of
17 Photovoltaic-Wind Turbine Grid Connected Systems,” *IEEE Trans. Energy Convers.*, vol. 28, no. 2,
18 pp. 370–379, Jun. 2013.
- 19 [24] T. Ma, H. Yang, L. Lu, and J. Peng, “Technical feasibility study on a standalone hybrid solar-wind
20 system with pumped hydro storage for a remote island in Hong Kong,” *Renew. Energy*, vol. 69, pp.
21 7–15, Sep. 2014.
- 22 [25] M. Kapsali, J. S. Anagnostopoulos, and J. K. Kaldellis, “Wind powered pumped-hydro storage
23 systems for remote islands: A complete sensitivity analysis based on economic perspectives,” *Appl.*
24 *Energy*, vol. 99, pp. 430–444, Nov. 2012.
- 25 [26] G. Baquero, B. Esteban, J.-R. Riba, A. Rius, and R. Puig, “An evaluation of the life cycle cost of
26 rapeseed oil as a straight vegetable oil fuel to replace petroleum diesel in agriculture,” *Biomass and*
27 *Bioenergy*, vol. 35, no. 8, pp. 3687–3697, Aug. 2011.
- 28 [27] Amerisolar, “AmeriSolar AS-5M,” 2013. [Online]. Available: <http://www.weamerisolar.com/>.
- 29 [28] Generation Wind Ltd, “SUT200 wind turbine,” 2014. [Online]. Available:
30 <http://www.generationwindturbines.com/en/our-turbines/product-range/sut-200>.
- 31 [29] IDESCAT, “Santa Coloma de Queralt - The township in figures,” 2011. [Online]. Available:
32 <http://www.idescat.cat/emex/?id=431397#h40000>.
- 33 [30] Electra Caldense, “Hourly demand data.” Caldes de Montbui, Spain, 2011.
- 34 [31] IDAE, “Análisis del consumo energético del sector residencial en España INFORME FINAL,”
35 Madrid, Spain, 2011.

- 1 [32] Eurostat, “Electricity and Natural Gas price statistics,” 2014. [Online]. Available:
2 [http://epp.eurostat.ec.europa.eu/statistics_explained/index.php/electricity_and_natural_gas_price_sta](http://epp.eurostat.ec.europa.eu/statistics_explained/index.php/electricity_and_natural_gas_price_statistics)
3 [tistics](http://epp.eurostat.ec.europa.eu/statistics_explained/index.php/electricity_and_natural_gas_price_statistics).
- 4 [33] Meteorological Service of Catalonia (Meteocat), “Hourly data of UJ automatic weather station.”
5 Generalitat de Catalunya, Barcelona, Spain, 2012.
- 6 [34] S. Blumsack and K. Richardson, “Cost and emissions implications of coupling wind and solar
7 power,” *Smart Grid Renew. Energy*, vol. 3, no. 4, pp. 308–315, 2012.
- 8 [35] R. Dufo-López and J. L. Bernal-Agustín, “Design and control strategies of PV-Diesel systems using
9 genetic algorithms,” *Sol. Energy*, vol. 79, no. 1, pp. 33–46, 2005.
- 10 [36] J. Hernández-Moro and J. M. Martínez-Duart, “Analytical model for solar PV and CSP electricity
11 costs: Present LCOE values and their future evolution,” *Renew. Sustain. Energy Rev.*, vol. 20, pp.
12 119–132, 2013.
- 13 [37] R. Dufo-López, J. L. Bernal-Agustín, and F. Mendoza, “Design and economical analysis of hybrid
14 PV–wind systems connected to the grid for the intermittent production of hydrogen,” *Energy Policy*,
15 vol. 37, no. 8, pp. 3082–3095, Aug. 2009.
- 16 [38] INE, “Spain: Economic and financial data,” 2014. [Online]. Available:
17 <http://www.ine.es/dynt3/FMI/en/>.
- 18 [39] Agencia Tributaria, “Impuesto Sobre el Valor Añadido,” 2014. [Online]. Available:
19 [http://www.agenciatributaria.es/AEAT.internet/Inicio_es_ES/La_Agencia_Tributaria/Normativa/Nor](http://www.agenciatributaria.es/AEAT.internet/Inicio_es_ES/La_Agencia_Tributaria/Normativa/Normativa_tributaria_y_aduanera/Impuestos/Impuesto_sobre_el_valor_anadido__IVA_/Impuesto_sobre_el_valor_anadido__IVA_.shtml)
20 [mativa_tributaria_y_aduanera/Impuestos/Impuesto_sobre_el_valor_anadido__IVA_/Impuesto_sobre](http://www.agenciatributaria.es/AEAT.internet/Inicio_es_ES/La_Agencia_Tributaria/Normativa/Normativa_tributaria_y_aduanera/Impuestos/Impuesto_sobre_el_valor_anadido__IVA_/Impuesto_sobre_el_valor_anadido__IVA_.shtml)
21 [_el_valor_anadido__IVA_.shtml](http://www.agenciatributaria.es/AEAT.internet/Inicio_es_ES/La_Agencia_Tributaria/Normativa/Normativa_tributaria_y_aduanera/Impuestos/Impuesto_sobre_el_valor_anadido__IVA_/Impuesto_sobre_el_valor_anadido__IVA_.shtml).
- 22 [40] A. Goodrich, T. James, and M. Woodhouse, “Residential, Commercial, and Utility-Scale
23 Photovoltaic (PV) System Prices in the United States: Current Drivers and Cost-Reduction
24 Opportunities,” Golden, CO, USA, 2012.
- 25 [41] R. Wiser and M. Bolinger, “2012 Wind technologies market report,” 2013.
- 26 [42] OpenEI, “Transparent cost database,” 2012. [Online]. Available: <http://en.openei.org/apps/TCDB/>.
- 27 [43] OMIE, “Resultados del mercado diario,” 2011. [Online]. Available: <http://www.omie.es/inicio>.
- 28 [44] Elèctrica de Santa Coloma, “High voltage price 3.0 fare.” 2014.
- 29 [45] Endesa, “High voltage time periods,” 2014. [Online]. Available:
30 https://www.endesaonline.com/ES/empresas/luz/tarifas_electricas_empresas_alta_tension/optima/ho
31 [ras/index.asp](https://www.endesaonline.com/ES/empresas/luz/tarifas_electricas_empresas_alta_tension/optima/ho).
- 32 [46] OMIE, “Precio final anual de demanda nacional,” 2014. [Online]. Available:
33 <http://www.omie.es/files/flash/ResultadosMercado.swf>.

- 1 [47] Alliance for Sustainable Energy, “PV Watts calculator.” National Renewable Energy Laboratory
2 (NREL), Golden, CO, USA, 2013.
- 3 [48] R. Luna-Rubio, M. Trejo-Perea, D. Vargas-Vázquez, and G. J. Ríos-Moreno, “Optimal sizing of
4 renewable hybrids energy systems: A review of methodologies,” *Sol. Energy*, vol. 86, no. 4, pp.
5 1077–1088, 2012.
- 6 [49] J. L. Bernal-Agustín and R. Dufo-López, “Efficient design of hybrid renewable energy systems
7 using evolutionary algorithms,” *Energy Convers. Manag.*, vol. 50, no. 3, pp. 479–489, 2009.
- 8 [50] E. Koutroulis, D. Kolokotsa, A. Potirakis, and K. Kalaitzakis, “Methodology for optimal sizing of
9 stand-alone photovoltaic/wind-generator systems using genetic algorithms,” *Sol. Energy*, vol. 80, no.
10 9, pp. 1072–1088, 2006.
- 11 [51] R. Baños, F. Manzano-Agugliaro, F. G. Montoya, C. Gil, A. Alcayde, and J. Gómez, “Optimization
12 methods applied to renewable and sustainable energy: A review,” *Renew. Sustain. Energy Rev.*, vol.
13 15, no. 4, pp. 1753–1766, 2011.

14