



**UNIVERSITAT POLITÈCNICA
DE CATALUNYA**

**ERASMUS STUDENT EXCHANGE PROJECT:
DESIGN AND IMPLEMENTATION OF UHF PATCH ANTENNA**

ERASMUS STUDENT:

ALEKSANDER SYNAK

SUPERVISOR:

PROFESSOR IGNACIO GIL

Index:

1.	Introduction.....	3
2.	Antennas.....	3
2.1.	What is antenna.....	3
2.2.	Types of antennas.....	3
2.3.	Patch antennas.....	6
3.	Antenna parameters.....	9
3.1.	Radiation pattern.....	9
3.2.	Directivity.....	12
3.3.	Antenna efficiency.....	13
3.4.	Gain.....	15
3.5.	Bandwidth.....	17
3.6.	Polarization.....	18
3.7.	Input impedance.....	20
3.8.	S_{11} parameters on Smith chart.....	22
3.9.	Antenna measurement techniques.....	23
4.	Tools and methods.....	25
4.1.	ADS.....	25
4.2.	FSV.....	26
5.	Project - Design and implementation of patch antenna: Inverted F-Antenna (<i>IFA</i>) on 868 MHz.....	28
5.1.	General information.....	28
5.2.	Momentum microwave simulation.....	30
5.3.	Measurements.....	35
6.	Conclusion.....	44
7.	References.....	37

1. Introduction.

This document contains the final report of designing and implementation of a patch antenna, among setting up of dimensions (more information is included in chapter 5.1), comparing results from Momentum Microwave and real measurements, analyzing S_{11} parameters and others. At the beginning it intends to explain what an antenna is. Then, types of antenna and characteristic of patch antenna will be presented. Next chapter is devoted to explain the main parameters of antennas, for example radio patterns, directivity, gain, polarization, efficiency and even measurement techniques. This report contains also tools and methods which have been used to design the specified antenna. Also it describes Feature Selective Validation (FSV) for Validation of Computational Electromagnetic (CEM). Program that was used to designing process is Advance Design System shared by Universitat Politècnica de Catalunya. Last chapter raises the main topic of this report, namely general information about designed antenna, simulation result, measurements, problems and final conclusion. At the end of document bibliography is attached.

2. Antennas.

2.1. What an antenna is?

What is antenna? Answer on that question can be little twisted, but it is justify: Piece of wire is not antenna even ignore that in this wire is flowing current generated by hundreds or thousands transmitters placed in some close area. In other side, when we plug in this wire to radio working on VHF and when it fulfill expectations also make better receiving, then our wire become a antenna.

2.2. Types of antennas.

Now will be introduce and briefly discuss some forms of the various antenna types.

Wire antennas

Wire antennas are familiar to the layman because they are seen virtually everywhere on automobiles, buildings, ships, aircraft, spacecraft, and so on. There are various shapes of wire antennas such as a straight wire (dipole), loop, and helix which are shown in Figure 2.1. Loop antennas need not only be circular. They may take the form of a rectangle, square, ellipse, or any other configuration. The circular loop is the most common because of its simplicity in construction.

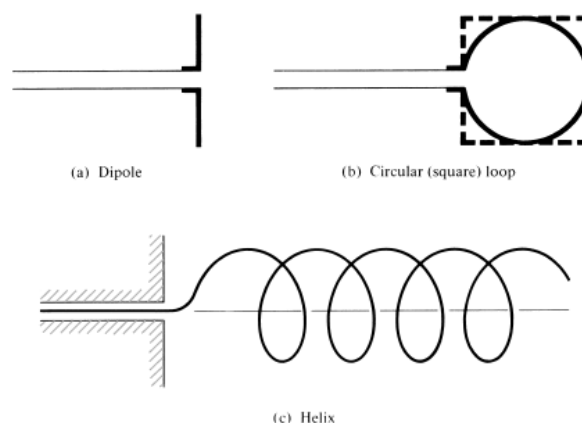

Figure 2.1. Wire antenna configuration.

Aperture antennas

Aperture antennas may be more familiar to the layman today than in the past because of the increasing demand for more sophisticated forms of antennas and the utilization of higher frequencies. Some forms of aperture antennas are shown in Figure 2.2. Antennas of this type are very useful for aircraft and spacecraft applications, because they can be very conveniently flush-mounted on the skin of the aircraft or spacecraft. In addition, they can be covered with a dielectric material to protect them from hazardous conditions of the environment.

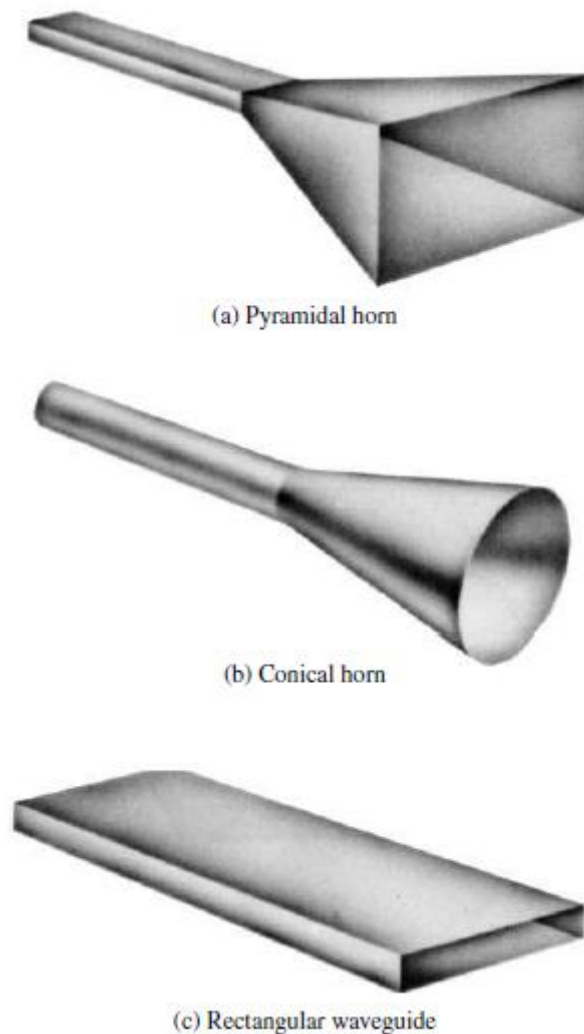

Figure 2.2. Aperture antenna configuration.

Microstrip antennas

Microstrip antennas became very popular in the 1970s primarily for space borne applications. Today they are used for government and commercial applications. These antennas consist of a metallic patch on a grounded substrate. The metallic patch can take many different configurations. However, the rectangular and circular patches, shown in Figure 2.3, are the most popular because of ease of analysis and fabrication, and their attractive radiation characteristics, especially low cross-polarization radiation. The microstrip antennas are low profile, conformable to planar and nonplanar surfaces, simple and inexpensive to fabricate using modern printed-circuit technology, mechanically robust when mounted on rigid surfaces, compatible with MMIC (Monolithic Microwave Integrated Circuit)

Design and implementation of patch antenna

designs, and very versatile in terms of resonant frequency, polarization, pattern, and impedance. These antennas can be mounted on the surface of high-performance aircraft, spacecraft, satellites, missiles, cars, and even handheld mobile telephones.

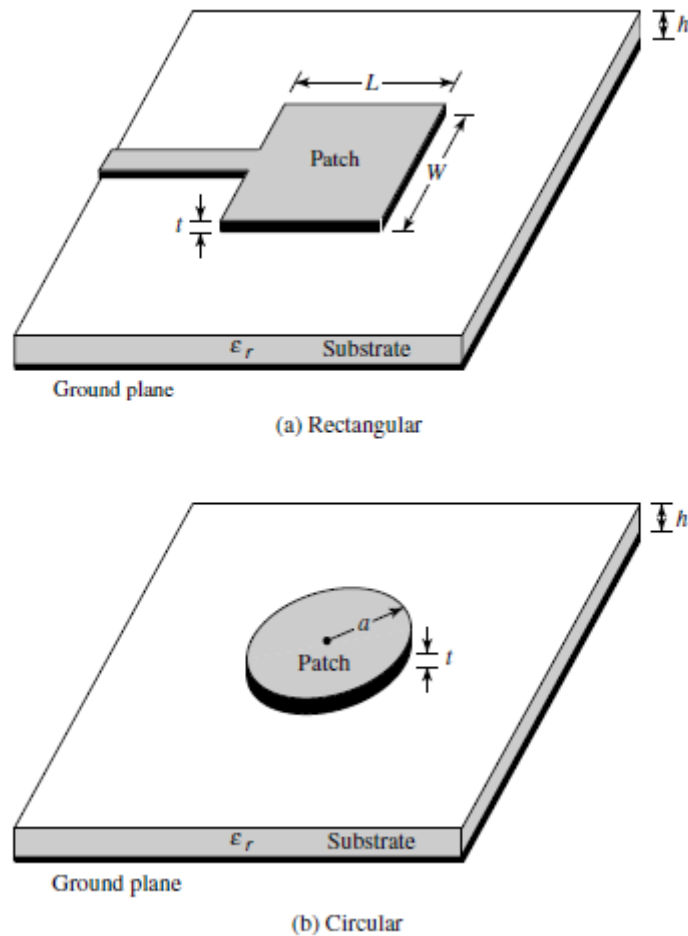

Figure 2.3. Patch antennas.

Array antennas

Many applications require radiation characteristics that may not be achievable by a single element. It may, however, be possible that an aggregate of radiating elements in an electrical and geometrical arrangement (*an array*) will result in the desired radiation characteristics. The arrangement of the array may be such that the radiation from the elements adds up to give a radiation maximum in a particular direction or directions, minimum in others, or otherwise as desired. Typical examples of arrays are shown in Figure 1.6. Usually the term *array* is reserved for an arrangement in which the individual radiators are separate as shown in Figures 2.4(a–c).

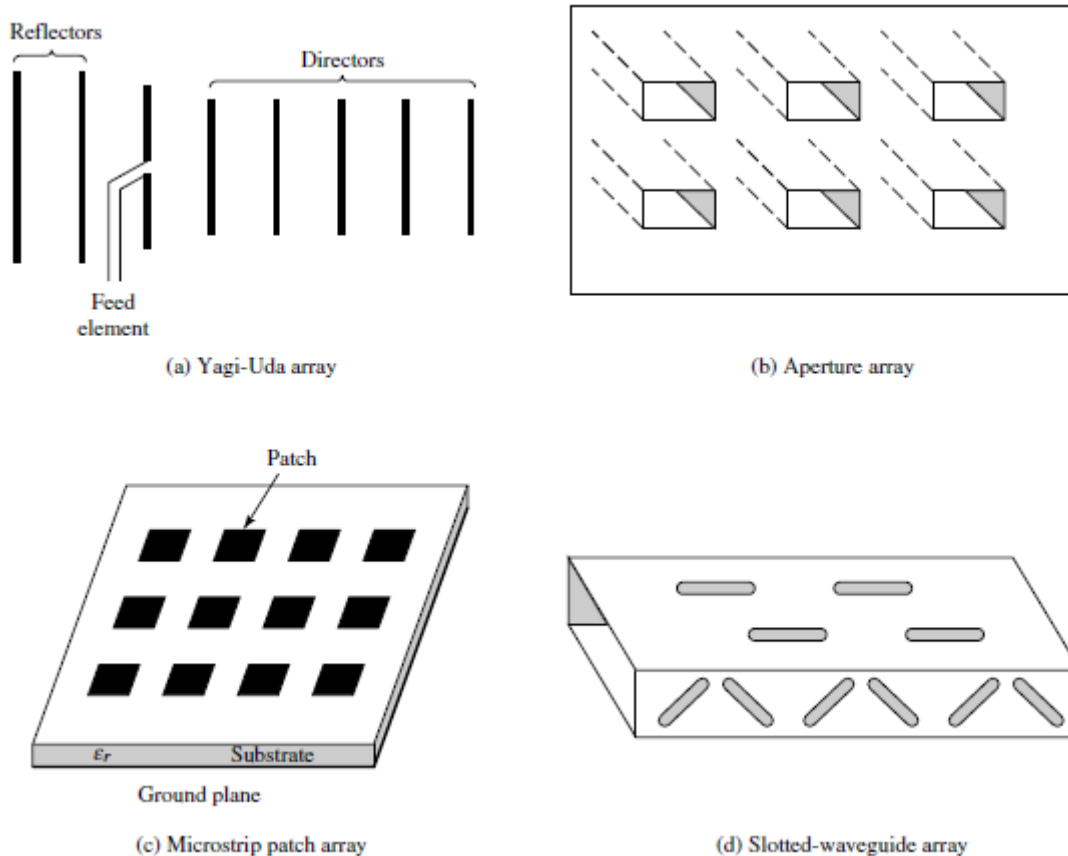

Figure 2.4. Arrays antennas configuration.

Lens antennas

Lenses are primarily used to collimate incident divergent energy to prevent it from spreading in undesired directions. By properly shaping the geometrical configuration and choosing the appropriate material of the lenses, they can transform various forms of divergent energy into plane waves. They can be used in most of the same applications as are the parabolic reflectors, especially at higher frequencies. Their dimensions and weight become exceedingly large at lower frequencies. Lens antennas are classified according to the material from which they are constructed, or according to their geometrical shape. In summary, an ideal antenna is one that will radiate all the power delivered to it from the transmitter in a desired direction or directions. In practice, however, such ideal performances cannot be achieved but may be closely approached. Various types of antennas are available and each type can take different forms in order to achieve the desired radiation characteristics for the particular application.

2.3. Patch antennas.

In high-performance aircraft, spacecraft, satellite, and missile applications, where size, weight, cost, performance, ease of installation, and aerodynamic profile are constraints, low-profile antennas may be required. Presently there are many other government and commercial applications, such as mobile radio and wireless communications, that have similar specifications. To meet these requirements, patch antennas (microstrip, copolar, etc.) can be used. These antennas are low profile, conformable to planar and nonplanar surfaces, simple and inexpensive to manufacture using modern printed-circuit technology, mechanically robust when mounted on rigid surfaces, compatible with

Design and implementation of patch antenna

MMIC designs, and when the particular patch shape and mode are selected, they are very versatile in terms of resonant frequency, polarization, pattern, and impedance. In addition, by adding loads between the patch and the ground plane, such as pins and varactor diodes, adaptive elements with variable resonant frequency, impedance, polarization, and pattern can be designed.

Major operational disadvantages of microstrip antennas are their low efficiency, low power, high Q (sometimes in excess of 100), poor polarization purity, poor scan performance, spurious feed radiation and very narrow frequency bandwidth, which is typically only a fraction of a percent or at most a few percent. In some applications, such as in government security systems, narrow bandwidths are desirable. However, there are methods, such as increasing the height of the substrate, that can be used to extend the efficiency (to as large as 90 percent if surface waves are not included) and bandwidth (up to about 35 percent). However, as the height increases, surface waves are introduced which usually are not desirable because they extract power from the total available for direct radiation (space waves). The surface waves travel within the substrate and they are scattered at bends and surface discontinuities, such as the truncation of the dielectric and ground plane, and degrade the antenna pattern and polarization characteristics. Surface waves can be eliminated, while maintaining large bandwidths, by using cavities. Stacking, as well as other methods, of microstrip elements can also be used to increase the bandwidth. In addition, microstrip antennas also exhibit large electromagnetic signatures at certain frequencies outside the operating band, are rather large physically at VHF and possibly UHF frequencies, and in large arrays there is a trade-off between bandwidth and scan volume.

Basic characteristics

Microstrip antennas received considerable attention starting in the 1970s, although the idea of a microstrip antenna can be traced to 1953 and a patent in 1955. Microstrip antennas, as shown in Figure 2.5(a), consist of a very thin ($t \equiv$ thickness) ($t \ll \lambda_0$, where λ_0 is the free-space wavelength) metallic strip (patch) placed a small fraction of a wavelength ($h \ll \lambda_0$, usually $0.003\lambda_0 \leq h \leq 0.05\lambda_0$) above a ground plane. The microstrip patch is designed so its pattern maximum is normal to the patch (broadside radiator). This is accomplished by properly choosing the mode (field configuration) of excitation beneath the patch. End-fire radiation can also be accomplished by judicious mode selection. For a rectangular patch, the length L of the element is usually $\lambda_0/3 < L < \lambda_0/2$. The strip (patch) and the ground plane are separated by a dielectric sheet (referred to as the substrate), as shown in Figure 2.5(a).

There are numerous substrates that can be used for the design of microstrip antennas, and their dielectric constants are usually in the range of $2.2 \leq \epsilon_r \leq 12$. The ones that are most desirable for good antenna performance are thick substrates whose dielectric constant is in the lower end of the range because they provide better efficiency, larger bandwidth, loosely bound fields for radiation into space, but at the expense of larger element size. Thin substrates with higher dielectric constants are desirable for microwave circuitry because they require tightly bound fields to minimize undesired radiation and coupling, and lead to smaller element sizes; however, because of their greater losses, they are less efficient and have relatively smaller bandwidths. Since microstrip antennas are often integrated with other microwave circuitry, a compromise has to be reached between good antenna performance and circuit design.

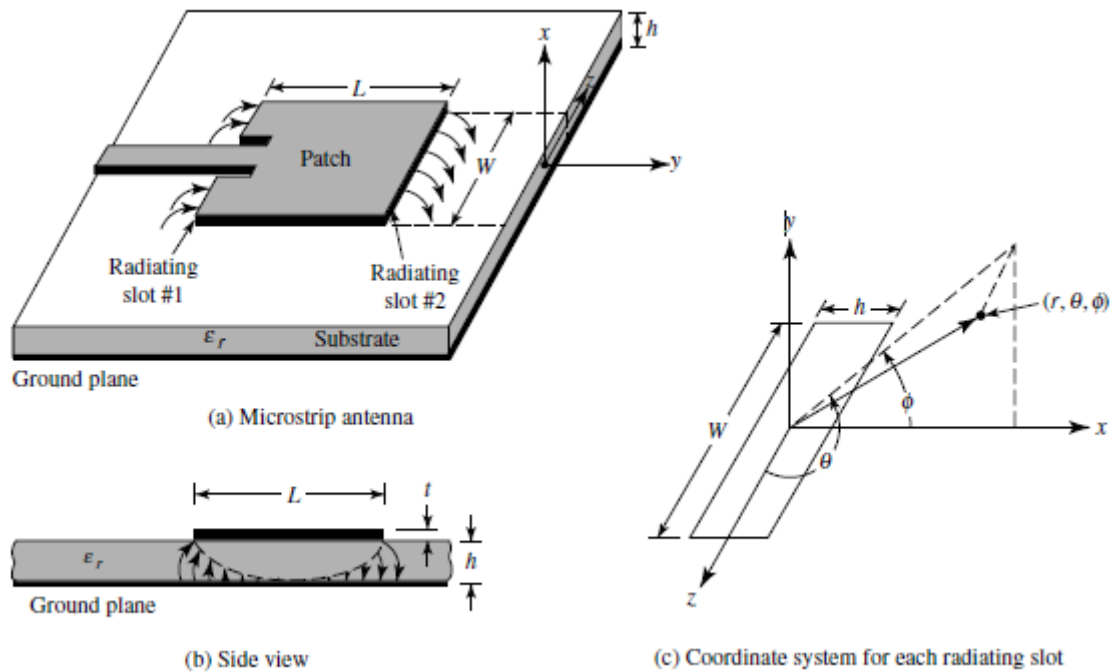

Figure 2.5. Microstrip antenna and coordination system.

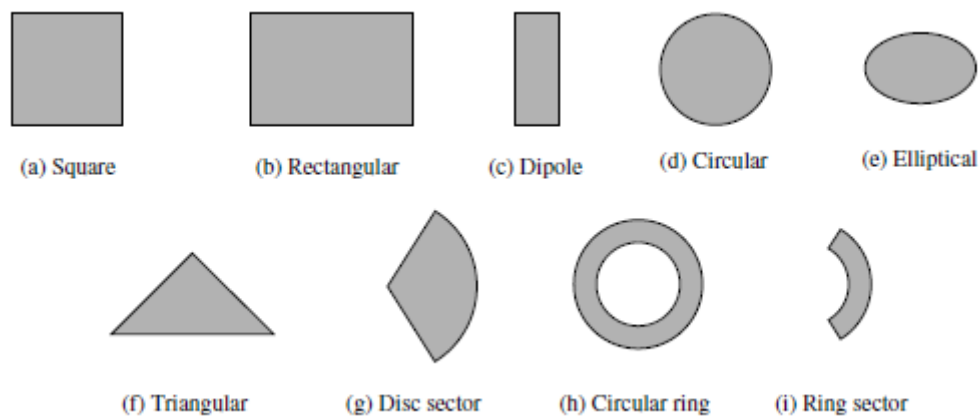

Figure 2.6. Shapes of patches.

Often microstrip antennas are also referred to as *patch* antennas. The radiating elements and the feed lines are usually photo etched on the dielectric substrate. The radiating patch may be square, rectangular, thin strip (dipole), circular, elliptical, triangular, or any other configuration. These and others are illustrated in Figure 2.6. Square, rectangular, dipole (strip), and circular are the most common because of ease of analysis and fabrication, and their attractive radiation characteristics, especially low cross-polarization radiation. Microstrip dipoles are attractive because they inherently possess a large bandwidth and occupy less space, which makes them attractive for arrays. Linear and circular polarizations can be achieved with either single elements or arrays of microstrip antennas. Arrays of microstrip elements, with single or multiple feeds, may also be used to introduce scanning capabilities and achieve greater directivities. These will be discussed in later sections.

3. Antenna parameters.

3.1. Radiation pattern.

An antenna radiation pattern or antenna pattern is defined as “a mathematical function or a graphical representation of the radiation properties of the antenna as a function of space coordinates. In most cases, the radiation pattern is determined in the far field region and is represented as a function of the directional coordinates. Radiation properties include power flux density, radiation intensity, field strength, directivity, phase or polarization.” The radiation property of most concern is the two- or three-dimensional spatial distribution of radiated energy as a function of the observer’s position along a path or surface of constant radius. A convenient set of coordinates is shown in Figure 3.1. A trace of the received electric (magnetic) field at a constant radius is called the amplitude field pattern. On the other hand, a graph of the spatial variation of the power density along a constant radius is called an amplitude power pattern.

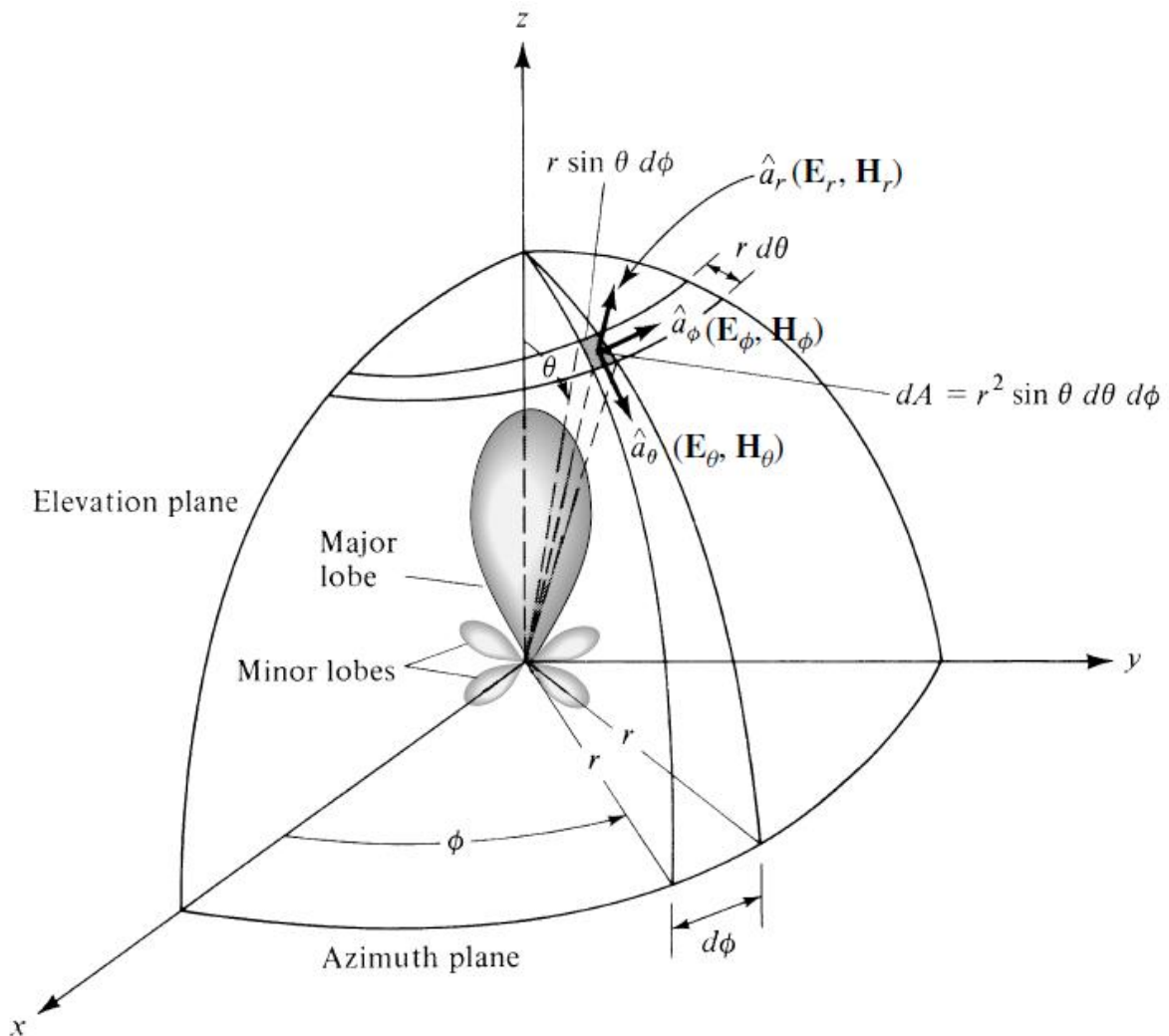

Figure 3.1. Coordinate system for antenna analysis.

Often the field and power patterns are normalized with respect to their maximum value, yielding normalized field and power patterns. Also, the power pattern is usually plotted on a logarithmic scale or more commonly in decibels (dB). This scale is usually desirable because a

Design and implementation of patch antenna

logarithmic scale can accentuate in more details those parts of the pattern that have very low values, which later we will refer to as minor lobes. For an antenna, the

a) *field pattern (in linear scale)* typically represents a plot of the magnitude of the electric or magnetic field as a function of the angular space.

b) *power pattern (in linear scale)* typically represents a plot of the square of the magnitude of the electric or magnetic field as a function of the angular space.

c) *power pattern (in dB)* represents the magnitude of the electric or magnetic field, in decibels, as a function of the angular space.

To demonstrate this, the two-dimensional normalized field pattern (*plotted in linear scale*), power pattern (*plotted in linear scale*), and power pattern (*plotted on a logarithmic dB scale*) of a 10-element linear antenna array of isotropic sources, with a spacing of $d = 0.25\lambda$ between the elements, are shown in Figure 3.2. *In this and subsequent patterns, the plus (+) and minus (-) signs in the lobes indicate the relative polarization of the amplitude between the various lobes, which changes (alternates) as the nulls are crossed.* To find the points where the pattern achieves its half-power (-3 dB points), relative to the maximum value of the pattern, you set the value of the

a) field pattern at 0.707 value of its maximum, as shown in Figure 3.2(a)

b) power pattern (in a linear scale) at its 0.5 value of its maximum, as shown in Figure 3.2(b)

c) power pattern (in dB) at -3 dB value of its maximum, as shown in Figure 3.2(c).

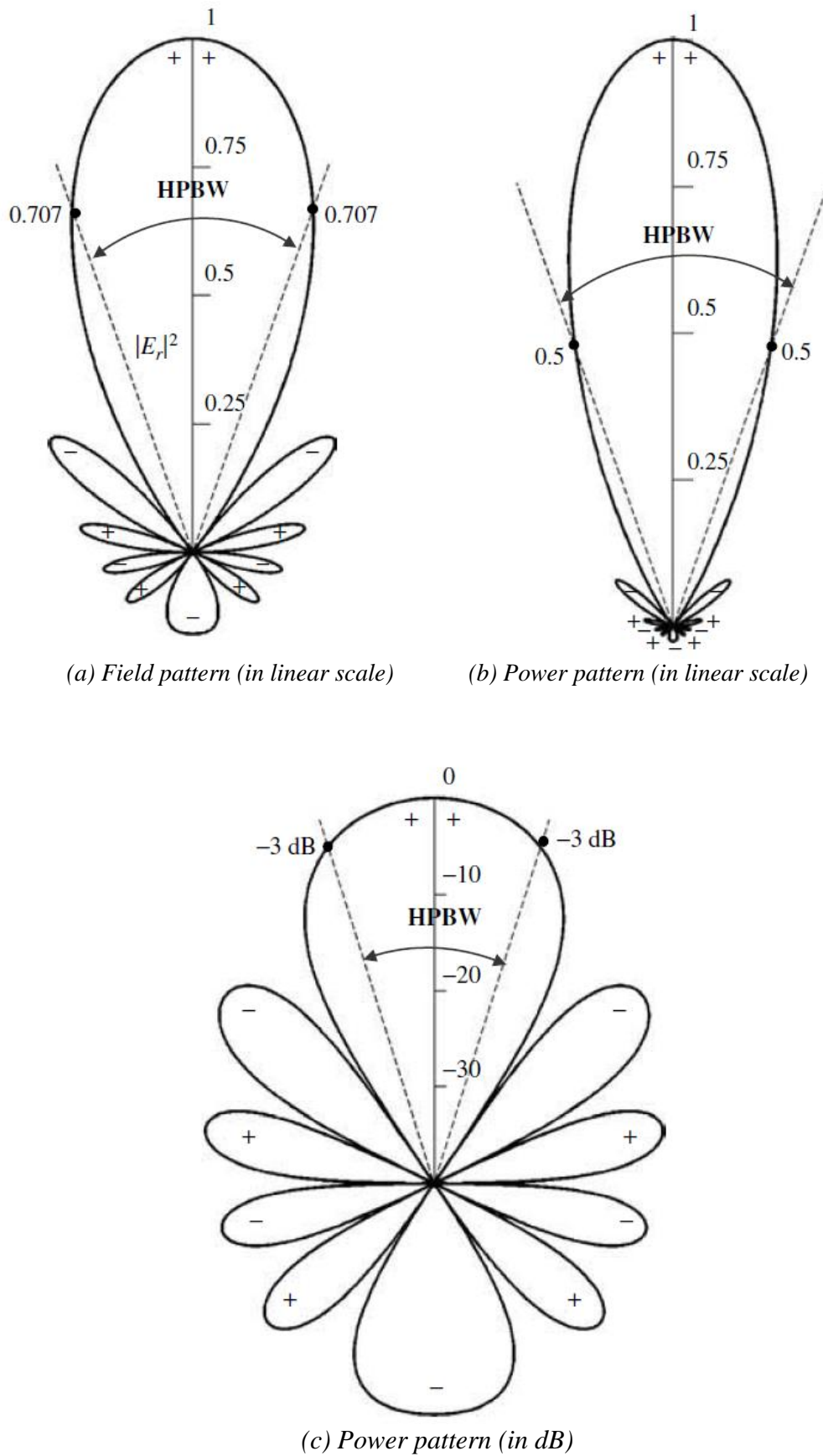

Figure 3.2. Two-dimensional normalized field pattern(linear scale), power pattern(linear scale), and power pattern(in dB) of a 10-element linear array with a spacing of $d = 0.25\lambda$.

All three patterns yield the same angular separation between the two half-power points, 38.64° , on their respective patterns, referred to as *HPBW* and illustrated in Figure 3.2.

The *Half-Power Beamwidth (HPBW)* is one of the most widely used beamwidths, which is defined by IEEE as: “In a plane containing the direction of the maximum of a beam, the angle between the two directions in which the radiation intensity is one-half value of the beam.”

In practice, the three-dimensional pattern is measured and recorded in a series of two-dimensional patterns. However, for most practical applications, a few plots of the pattern as a function of θ for some particular values of ϕ , plus a few plots as a function of ϕ for some particular values of θ , give most of the useful and needed information.

3.2. Directivity.

In the 1983 version of the IEEE Standard Definitions of Terms for Antennas, there has been a substantive change in the definition of directivity, compared to the definition of the 1973 version. Basically the term directivity in the new 1983 version has been used to replace the term directive gain of the old 1973 version. In the new 1983 version the term directive gain has been deprecated. According to the authors of the new 1983 standards, “this change brings this standard in line with common usage among antenna engineers and with other international standards, notably those of the International Electrotechnical Commission (IEC).” Therefore directivity of an antenna defined as “the ratio of the radiation intensity in a given direction from the antenna to the radiation intensity averaged over all directions. The average radiation intensity is equal to the total power radiated by the antenna divided by 4π . If the direction is not specified, the direction of maximum radiation intensity is implied.” Stated more simply, the directivity of a non-isotropic source is equal to the ratio of its radiation intensity in a given direction over that of an isotropic source. In mathematical form, using (3-1),

$$U_0 = \frac{P_{\text{rad}}}{4\pi} \quad (3-1)$$

it can be written as:

$$D = \frac{U}{U_0} = \frac{4\pi U}{P_{\text{rad}}} \quad (3-2)$$

If the direction is not specified, it implies the direction of maximum radiation intensity (maximum directivity) expressed as

$$D_{\text{max}} = |D_0 = \frac{U|_{\text{max}}}{U_0} = \frac{U_{\text{max}}}{U_0} = \frac{4\pi U_{\text{max}}}{P_{\text{rad}}} \quad (3-2a)$$

D = directivity (dimensionless)

D_0 = maximum directivity (dimensionless)

Design and implementation of patch antenna

U = radiation intensity (W/unit solid angle)

U_{\max} = maximum radiation intensity (W/unit solid angle)

U_0 = radiation intensity of isotropic source (W/unit solid angle)

P_{rad} = total radiated power (W)

For anisotropic source, it is very obvious from (3-2) or (3-2a) that the directivity is unity since U , U_{\max} , and dU_0 are all equal to each other. For antennas with orthogonal polarization components, we define the *partial directivity of an antenna for a given polarization in a given direction* as “that part of the radiation intensity corresponding to a given polarization divided by the total radiation intensity averaged over all directions.” With this definition for the partial directivity, then in a given direction “the total directivity is the sum of the partial directivities for any two orthogonal polarizations.” For a spherical coordinate system, the total maximum directivity D_0 for the orthogonal θ and ϕ components of an antenna can be written as

$$D_0 = D_\theta + D_\phi \quad (3-3)$$

while the partial directivities D_θ and D_ϕ are expressed as

$$D_\theta = \frac{4\pi U_\theta}{(P_{\text{rad}})_\theta + (P_{\text{rad}})_\phi} \quad (3-4a)$$

$$D_\phi = \frac{4\pi U_\phi}{(P_{\text{rad}})_\theta + (P_{\text{rad}})_\phi} \quad (3-4b)$$

where,

U_θ = radiation intensity in a given direction contained in θ field component

U_ϕ = radiation intensity in a given direction contained in ϕ field component

$(P_{\text{rad}})_\theta$ = radiated power in all directions contained in θ field component

$(P_{\text{rad}})_\phi$ = radiated power in all directions contained in ϕ field component

3.3. Antenna efficiency.

Associated with an antenna are a number of efficiencies and can be defined using Figure 3.3. The total antenna efficiency e_0 is used to take into account losses at the input terminals and within the structure of the antenna. Such losses may be due, referring to Figure 3.3(b), to

1. reflections because of the mismatch between the transmission line and the antenna
2. I^2R losses (conduction and dielectric)

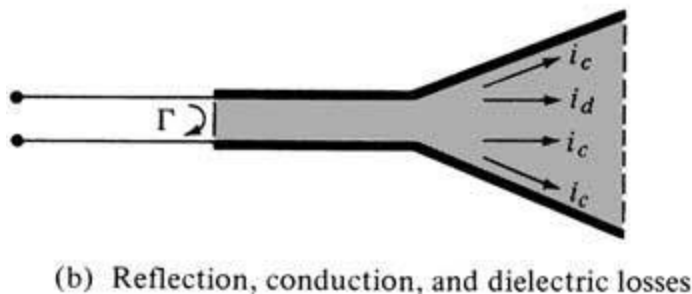
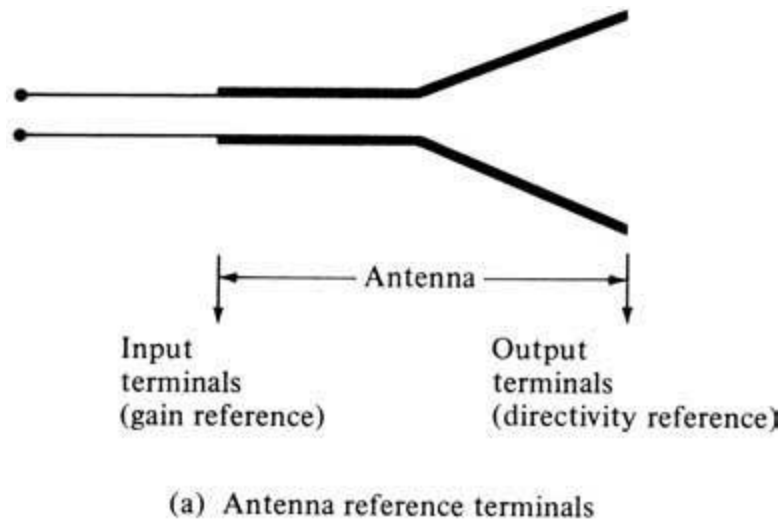

Figure 3.3. Reference terminals and losses of an antenna.

In general, the overall efficiency can be written as

$$e_0 = e_r e_c e_d \quad (3-5)$$

where

e_0 = total efficiency (dimensionless)

e_r = reflection(mismatch) efficiency = $(1 - |\Gamma|^2)$ (dimensionless)

e_c = conduction efficiency (dimensionless)

e_d = dielectric efficiency (dimensionless)

Γ = voltage reflection coefficient at the input terminals of the antenna

[$\Gamma = (Z_{in} - Z_0)/(Z_{in} + Z_0)$ where Z_{in} = antenna input impedance,

Z_0 = characteristic impedance of the transmission line]

$$\text{VSWR} = \text{voltage standing wave ratio} = \frac{1 + |\Gamma|}{1 - |\Gamma|}$$

Usually e_c and e_d are very difficult to compute, but they can be determined experimentally. Even by measurements they cannot be separated, and it is usually more convenient to write (3-5) as

$$e_0 = e_r e_{cd} = e_{cd}(1 - |\Gamma|^2) \quad (3-6)$$

where $e_{cd} = e_c e_d$ = antenna radiation efficiency, which is used to relate the gain and directivity.

3.4. Gain.

Another useful measure describing the performance of an antenna is the *gain*. Although the gain of the antenna is closely related to the directivity, it is a measure that takes into account the efficiency of the antenna as well as its directional capabilities. Remember that directivity is a measure that describes only the directional properties of the antenna, and it is therefore controlled only by the pattern.

Gain of an antenna (in a given direction) is defined as “the ratio of the intensity, in a given direction, to the radiation intensity that would be obtained if the power accepted by the antenna were radiated isotropically. The radiation intensity corresponding to the isotropically radiated power is equal to the power accepted (input) by the antenna divided by 4π .” In equation form this can be expressed as

$$\text{Gain} = 4\pi \frac{\text{radiation intensity}}{\text{total input (accepted) power}} = 4\pi \frac{U(\theta, \phi)}{|P_{in}|} \quad (\text{dimensionless}) \quad (3-7)$$

In most cases we deal with *relative gain*, which is defined as “the ratio of the power gain in a given direction to the power gain of a reference antenna in its referenced direction.” The power input must be the same for both antennas. The reference antenna is usually a dipole, horn, or any other antenna whose gain can be calculated or it is known. In most cases, however, the reference antenna is a *lossless isotropic source*. Thus

$$G = \frac{4\pi U(\theta, \phi)}{P_{in} (\text{lossless isotropic source})} \quad (\text{dimensionless}) \quad (3-7a)$$

When the direction is not stated, the power gain is usually taken in the direction of maximum radiation.

Referring to Figure 3.1(a), we can write that the total radiated power (P_{rad}) is related to the total input power (P_{in}) by

$$P_{rad} = e_{cd} P_{in} \quad (3-9)$$

where e_{cd} is the antenna radiation efficiency (dimensionless) which is defined in (3-5), (3-6). According to the IEEE Standards, “gain does not include losses arising from impedance mismatches (reflection losses) and polarization mismatches (losses).”

Design and implementation of patch antenna

In this document we define two gains; one, referred to as *gain* (G), and the other, referred to as *absolute gain* (G_{abs}), that also takes into account the reflection/mismatch losses represented in both (3-5) and (3-6). Using (3-9) reduces (3-7a) to

$$G(\theta, \phi) = e_{cd} \left[4\pi \frac{U(\theta, \phi)}{P_{rad}} \right] \quad (3-10)$$

which is related to the directivity of (3-2) by

$$G(\theta, \phi) = e_{cd} D(\theta, \phi) \quad (3-11)$$

In a similar manner, the maximum value of the gain is related to the maximum directivity of (3-2a) by

$$G_0 = G(\theta, \phi)|_{\max} = e_{cd} D(\theta, \phi)|_{\max} = e_{cd} D_0 \quad (3-11a)$$

While (3-9) does take into account the losses of the antenna element itself, *it does not take into account the losses when the antenna element is connected to a transmission line*, as shown in Figure 3.1. These connection losses are usually referred to as *reflections (mismatch) losses*, and they are taken into account by introducing a reflection(mismatch) efficiency e_r , which is related to the reflection coefficient as shown in (3-6) or $e_r = (1 - |\Gamma|^2)$. Thus, we can introduce an *absolute gain* G_{abs} that takes into account the reflection/mismatch losses (due to the connection of the antenna element to the transmission line), and it can be written as

$$\begin{aligned} G_{abs}(\theta, \phi) &= e_r G(\theta, \phi) = (1 - |\Gamma|^2) G(\theta, \phi) \\ &= e_r e_{cd} D(\theta, \phi) = e_o D(\theta, \phi) \end{aligned} \quad (3-12)$$

where e_o is the overall efficiency as defined in (3-6), (3-7). Similarly, the *maximum absolute gain* G_{0abs} of (3-11a) is related to the maximum directivity D_0 by

$$\begin{aligned} G_{0abs} &= G_{abs}(\theta, \phi)|_{\max} = e_r G(\theta, \phi)|_{\max} = (1 - |\Gamma|^2) G(\theta, \phi)|_{\max} \\ &= e_r e_{cd} D(\theta, \phi)|_{\max} = e_o D(\theta, \phi)|_{\max} = e_o D_0 \end{aligned} \quad (3-13)$$

If the antenna is matched to the transmission line, that is, the antenna input impedance Z_{in} is equal to the characteristic impedance Z_c of the line ($|\Gamma| = 0$), then the two gains are equal ($G_{abs} = G$).

As was done with the directivity, we can define the *partial gain of an antenna for a given polarization in a given direction* as “that part of the radiation intensity corresponding to a given polarization divided by the total radiation intensity that would be obtained if the power accepted by the antenna were radiated isotropically.” With this definition for the partial gain, then, in a given direction, “the total gain is the sum of the partial gains for any two orthogonal polarizations.” For a spherical

Design and implementation of patch antenna

coordinate system, the total maximum gain G_0 for the orthogonal θ and ϕ components of an antenna can be written, in a similar form as was the maximum directivity in (3-3)–(3-4b), as

$$G_0 = G_\theta + G_\phi \quad (3-14)$$

while the partial gains G_θ and G_ϕ are expressed as

$$G_\theta = \frac{4\pi U_\theta}{P_{in}} \quad (3-14a)$$

$$G_\phi = \frac{4\pi U_\phi}{P_{in}} \quad (3-14b)$$

where

U_θ = radiation intensity in a given direction contained in E_θ field component

U_ϕ = radiation intensity in a given direction contained in E_ϕ field component

P_{in} = total input (accepted) power

3.5. Bandwidth.

The *bandwidth* of an antenna is defined as “the range of frequencies within which the performance of the antenna, with respect to some characteristic, conforms to a specified standard.” The bandwidth can be considered to be the range of frequencies, on either side of a center frequency (usually the resonance frequency for a dipole), where the antenna characteristics (such as input impedance, pattern, beamwidth, polarization, side lobe level, gain, beam direction, radiation efficiency) are within an acceptable value of those at the center frequency. For broadband antennas, the bandwidth is usually expressed as the ratio of the upper-to-lower frequencies of acceptable operation. For example, a 10:1 bandwidth indicates that the upper frequency is 10 times greater than the lower. For narrowband antennas, the bandwidth is expressed as a percentage of the frequency difference (upper minus lower) over the center frequency of the bandwidth. For example, a 5% bandwidth indicates that the frequency difference of acceptable operation is 5% of the center frequency of the bandwidth.

Because the characteristics (input impedance, pattern, gain, polarization, etc.) of an antenna do not necessarily vary in the same manner or are even critically affected by the frequency, there is no unique characterization of the bandwidth. The specifications are set in each case to meet the needs of the particular application. Usually there is a distinction made between pattern and input impedance variations. Accordingly *pattern bandwidth* and *impedance bandwidth* are used to emphasize this distinction. Associated with pattern bandwidth are gain, side lobe level, beamwidth, polarization, and beam direction while input impedance and radiation efficiency are related to impedance bandwidth. For example, the pattern of a linear dipole with overall length less than a half-wavelength ($l < \lambda/2$) is insensitive to frequency. The limiting factor for this antenna is its impedance, and its bandwidth can be formulated in terms of the Q . The Q of antennas or arrays with dimensions large compared to the wavelength, excluding superdirective designs, is near unity. Therefore the bandwidth is usually formulated in terms of beamwidth, side lobe level, and pattern characteristics. For intermediate length antennas, the bandwidth may be limited by either pattern or impedance variations, depending upon the

Design and implementation of patch antenna

particular application. For these antennas, a 2:1 bandwidth indicates a good design. For others, large bandwidths are needed. Antennas with very large bandwidths (like 40:1 or greater) have been designed in recent years.

The above discussion presumes that the coupling networks (transformers, baluns, etc.) and/or the dimensions of the antenna are not altered in any manner as the frequency is changed. It is possible to increase the acceptable frequency range of a narrowband antenna if proper adjustments can be made on the critical dimensions of the antenna and/or on the coupling networks as the frequency is changed. Although not an easy or possible task in general, there are applications where this can be accomplished. The most common examples are the antenna of a car radio and the “rabbit ears” of a television. Both usually have adjustable lengths which can be used to tune the antenna for better reception.

3.6. Polarization.

Polarization of an antenna in a given direction is defined as “the polarization of the wave transmitted (radiated) by the antenna. *Note:* When the direction is not stated, the polarization is taken to be the polarization in the direction of maximum gain.” In practice, polarization of the radiated energy varies with the direction from the center of the antenna, so that different parts of the pattern may have different polarizations.

Polarization of a radiated wave is defined as “that property of an electromagnetic wave describing the time-varying direction and relative magnitude of the electric-field vector; specifically, the figure traced as a function of time by the extremity of the vector at a fixed location in space, and the sense in which it is traced, *as observed along the direction of propagation.*” Polarization then is the curve traced by the end point of the arrow (vector) representing the instantaneous electric field. The field must be observed along the direction of propagation. A typical trace as a function of time is shown in Figures 3.4(a) and (b).

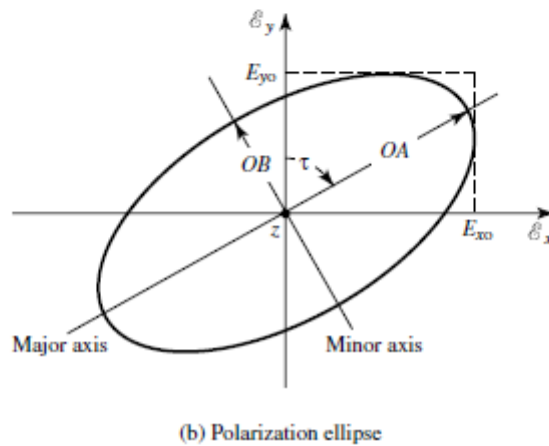
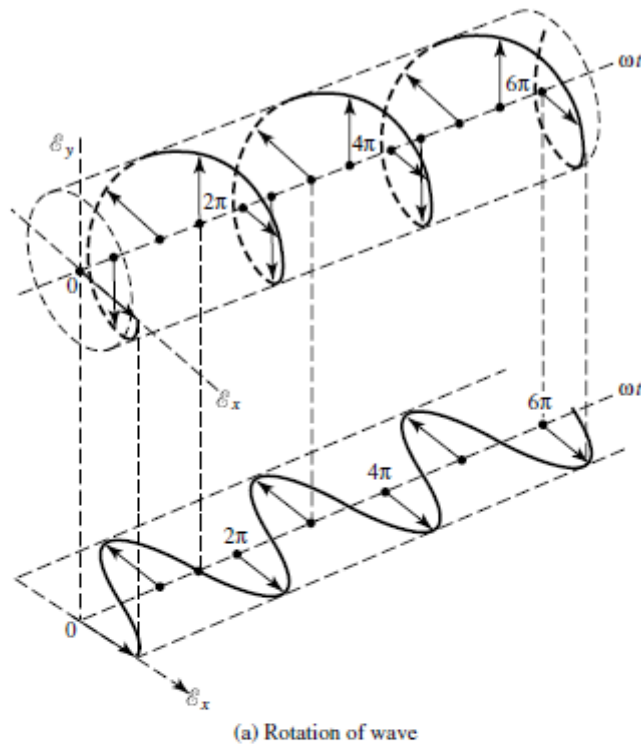

Figure 3.4. Rotation of a plane electromagnetic wave and its polarization ellipse at $z = 0$ as a function of time.

The polarization of a wave can be defined in terms of a wave *radiated (transmitted)* or *received* by an antenna in a given direction. The polarization of a wave *radiated* by an antenna in a specified direction at a point in the far field is defined as “the polarization of the (locally) plane wave which is used to represent the radiated wave at that point. At any point in the far field of an antenna the radiated wave can be represented by a plane wave whose electric-field strength is the same as that of the wave and whose direction of propagation is in the radial direction from the antenna. As the radial distance approaches infinity, the radius of curvature of the radiated wave’s phase front also approaches infinity and thus in any specified direction the wave appears locally as a plane wave.” The polarization of a wave *received* by an antenna is defined as the “polarization of a plane wave, incident from a given direction and having a given power flux density, which results in maximum available power at the antenna terminals.”

Polarization may be classified as linear, circular, or elliptical. If the vector that describes the electric field at a point in space as a function of time is always directed along a line, the field is said to be *linearly* polarized. In general, however, the figure that the electric field traces is an ellipse, and the field is said to be elliptically polarized. Linear and circular polarizations are special cases of elliptical, and they can be obtained when the ellipse becomes a straight line or a circle, respectively. The figure of the electric field is traced in a *clockwise* (CW) or *counterclockwise* (CCW) sense. *Clockwise* rotation of the electric-field vector is also designated as *right-hand polarization* and *counterclockwise* as *left-hand polarization*.

In general, the polarization characteristics of an antenna can be represented by its *polarization pattern* whose one definition is “the spatial distribution of the polarizations of a field vector excited (radiated) by an antenna taken over its radiation sphere. When describing the polarizations over the radiation sphere, or portion of it, reference lines shall be specified over the sphere, in order to measure the tilt angles (see tilt angle) of the polarization ellipses and the direction of polarization for linear polarizations. An obvious choice, though by no means the only one, is a family of lines tangent at each point on the sphere to either the θ or φ coordinate line associated with a spherical coordinate system of the radiation sphere. At each point on the radiation sphere the polarization is usually resolved into a pair of orthogonal polarizations, the *co-polarization* and *cross polarization*. To accomplish this, the co-polarization must be specified at each point on the radiation sphere.” “*Co-polarization* represents the polarization the antenna is intended to radiate (receive) while *cross-polarization* represents the polarization orthogonal to a specified polarization, which is usually the co-polarization.”

“For certain linearly polarized antennas, it is common practice to define the copolarization in the following manner: First specify the orientation of the co-polar electric-field vector at a pole of the radiation sphere. Then, for all other directions of interest (points on the radiation sphere), require that the angle that the co-polar electric-field vector makes with each great circle line through the pole remain constant over that circle, the angle being that at the pole.”

“In practice, the axis of the antenna’s main beam should be directed along the polar axis of the radiation sphere. The antenna is then appropriately oriented about this axis to align the direction of its polarization with that of the defined co-polarization at the pole.” “This manner of defining co-polarization can be extended to the case of elliptical polarization by defining the constant angles using the major axes of the polarization ellipses rather than the co-polar electric-field vector. The sense of polarization (rotation) must also be specified.”

The polarization of the wave radiated by the antenna can also be represented on the Poincaré sphere. Each point on the Poincaré sphere represents a unique polarization. The north pole represents left circular polarization, the south pole represents right circular, and points along the equator represent linear polarization of different tilt angles.

3.7. Input impedance.

Input impedance is defined as “the impedance presented by an antenna at its terminals or the ratio of the voltage to current at a pair of terminals or the ratio of the appropriate components of the electric to magnetic fields at a point.” In this section we are primarily interested in the input impedance at a pair of terminals which are the input terminals of the antenna. In Figure 3.5(a) these terminals are designated as $a - b$. The ratio of the voltage to current at these terminals, with no load attached, defines the impedance of the antenna as

$$Z_A = R_A + jX \tag{3-15}$$

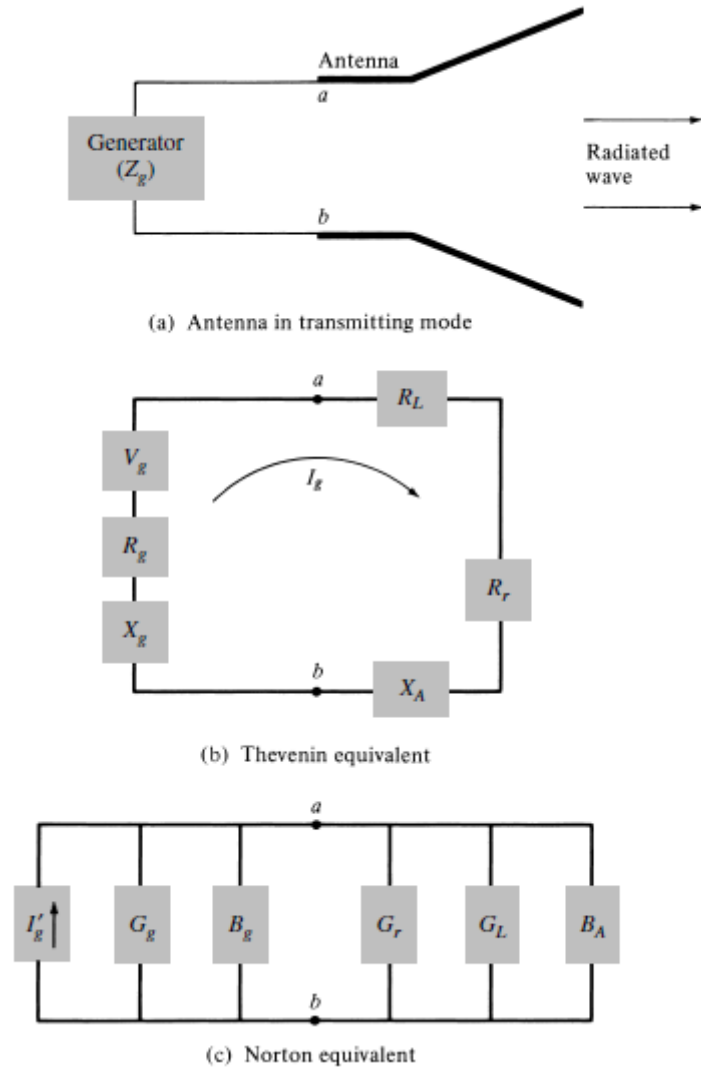

Figure 3.5. Transmitting antenna and its equivalent circuits.

where

Z_A = antenna impedance at terminals $a - b$ (ohms)

R_A = antenna resistance at terminals $a - b$ (ohms)

X_A = antenna reactance at terminals $a - b$ (ohms)

In general the resistive part of (3-15) consists of two components; that is

$$R_A = R_r + R_L \tag{3-16}$$

where

R_r = radiation resistance of the antenna

R_L = loss resistance of the antenna

3.8. S_{11} parameters on Smith chart.

The Smith chart, invented by Phillip H. Smith (1905–1987) is a graphical aid or nomogram designed for electrical and electronics engineers specializing in radio frequency (RF) engineering to assist in solving problems with transmission lines and matching circuits. Use of the Smith chart utility has grown steadily over the years and it is still widely used today, not only as a problem solving aid, but as a graphical demonstrator of how many RF parameters behave at one or more frequencies, an alternative to using tabular information. The Smith chart can be used to simultaneously display multiple parameters including impedances, admittances, reflection coefficients, S_{nn} scattering parameters, noise figure circles, constant gain contours and regions for unconditional stability, including mechanical vibrations analysis. The Smith chart is most frequently used at or within the unity radius region. However, the remainder is still mathematically relevant, being used, for example, in oscillator design and stability analysis.

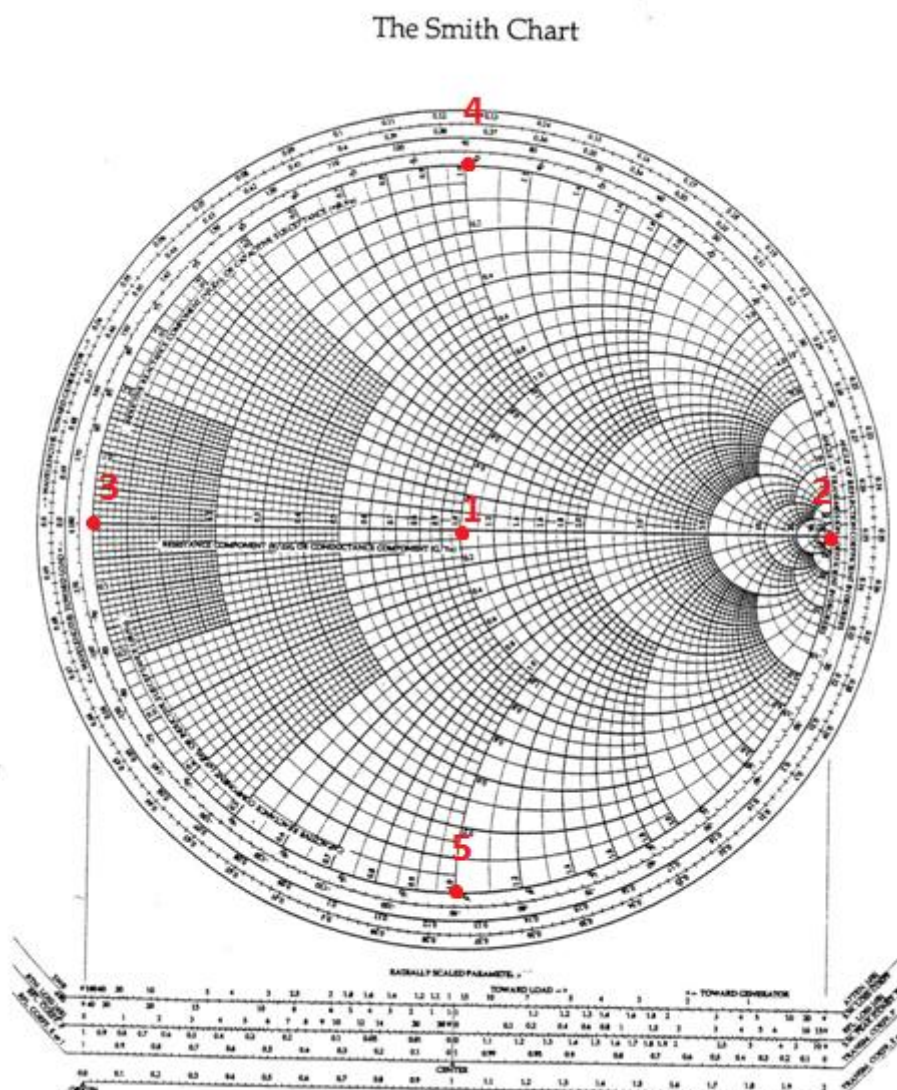

Figure 3.6. Smith chart.

Figure 3.6 shown Smith chart with the most important points:

- 1) ideal adjustment
- 2) open circuit
- 3) short circuit
- 4) clean inductance
- 5) clean capacity

3.9. Antenna measurement techniques.

In practice, the most commonly quoted parameter in regards to antennas is S_{11} . S_{11} represents how much power is reflected from the antenna, and hence is known as the reflection coefficient (sometimes written as gamma: Γ or return loss). If $S_{11}=0$ dB, then all the power is reflected from the antenna and nothing is radiated. If $S_{11} = -10$ dB, this implies that if 3 dB of power is delivered to the antenna, -7 dB is the reflected power. The remainder of the power was "accepted by" or delivered to the antenna. This accepted power is either radiated or absorbed as losses within the antenna. Since antennas are typically designed to be low loss, ideally the majority of the power delivered to the antenna is radiated.

Next measurement technique is a radiation pattern. A radiation pattern defines the variation of the power radiated by an antenna as a function of the direction away from the antenna. This power variation as a function of the arrival angle is observed in the antenna's far field.

Antenna measurements were made by using Agilent FieldFox handheld microwave analyzer N9916A shown in Figure 3.7. Frequency range of this device is 30 kHz - 14 GHz, work temperature is from -10 to 55 C degree, input impedance is 50 Ω (nominal). FieldFox N9916A was using to make a realistic S_{11} parameter of produced antenna on Smith chart and magnitude plot. To synchronize measurement device used Agilent CalKit 85521A with input impedance 50 Ω (figure 3.8).



Figure 3.7. Agilent Technologies FieldFox microwave analyzer N9916A.



Figure 3.8. Agilent Technologies CalKit 85521A.

4. Tools and methods.

4.1. ADS.

We have used Advanced Design System (ADS) as a software in order to make a simulations of antennas. ADS is an electronic design automation software system produced by Agilent EEsof EDA, a unit of Agilent Technologies. It provides an integrated design environment to designers of RF electronic products such as mobile phones, pagers, wireless networks, satellite communications, radar systems, and high-speed data links.

Agilent ADS supports every step of the design process—schematic capture, layout, frequency-domain and time-domain circuit simulation, and electromagnetic field simulation—allowing the engineer to fully characterize and optimize an RF design without changing tools.

Agilent EEsof has donated copies of the ADS software to the electrical engineering departments at many universities, and a large percentage of new graduates are experienced in its use. As a result, the system has found wide acceptance in industry.

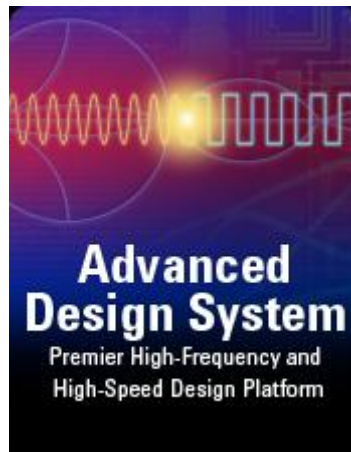

Figure 4.1. Agilent Technologies ADS logo.

Momentum Microwave Simulation

Method of moments estimation is based solely on the law of large numbers. Let M_1, M_2, \dots be independent random variables having a common distribution possessing a mean μ_M . Then the sample means converge to the distributional mean as the number of observations increase.

$$\bar{M}_n = \frac{1}{n} \sum_{i=1}^n M_i \rightarrow \mu_M \quad \text{as } n \rightarrow \infty.$$

Momentum is a part of Advanced Design System and gives you the simulation tools you need to evaluate and design modern communications systems products. Momentum is an electromagnetic simulator that computes S-parameters for general planar circuits, including microstrip, slotline, stripline, coplanar waveguide, and other topologies. Vias and airbridges connect topologies between layers, so you can simulate multilayer RF/microwave printed circuit boards, hybrids, multichip

Design and implementation of patch antenna

modules, and integrated circuits. Momentum gives you a complete tool set to predict the performance of high-frequency circuit boards, antennas, and ICs.

Momentum Optimization extends Momentum capability to a true design automation tool. The Momentum Optimization process varies geometry parameters automatically to help you achieve the optimal structure that meets the circuit or device performance goals. By using (parameterized) layout components you can also perform Momentum optimizations from the schematic page.

Momentum Visualization is an option that gives users a 3-dimensional perspective of simulation results, enabling you to view and animate current flow in conductors and slots, and view both 2D and 3D representations of far-field radiation patterns.

4.2. FSV.

Given that correlation lacked sensitivity for the visually complex data typical to EMC validation and the overall poor response of reliability functions to EMC validation, the FSV method was developed, which approached the task of validation using a reliability function-like approach but basing the general structure of the FSV within the context of the psychology of visual perception.

The FSV method is based on the decomposition of the original data into two parts: amplitude (trend/envelope) data and feature data. The former component accounts for the slowly varying data across the dataset and the latter accounts for the sharp peaks and troughs often found in EMC data. In response to the six applicability tests, the output of FSV can be viewed with a number of different levels of granularity. Specifically, these are as follows.

- 1) *Global difference measure (GDM)*. This is an overall single-figure goodness-of-fit between the two datasets being compared. This allows a simple decision to be made about the quality of a comparison. This may be numerical or converted to a natural language descriptor (excellent, very good, good, fair, poor, very poor). This is obtained from the overall figures for the two components, the amplitude difference measure (ADM), and the feature difference measure (FDM).
- 2) *ADM and FDM*. These are similarly available as a numerical value or converted to a natural language descriptor as for the GDM. These single-figure goodness-of-fit values combine to give the GDM.
- 3) *GDM_i, ADM_i, and FDM_i*. These are point-by-point comparisons of the amplitude differences, the feature differences, and the global difference. These allow users to analyze the resulting data in some detail, particularly with the aim of understanding the origin of the contributors to poor comparisons.
- 4) *GDM_c, ADM_c, and FDM_c*. These give a probability density function that shows the proportion of the point-by-point analyses of each of the components that falls into the six natural language descriptor categories. This provides a measure of confidence in the single-figure comparisons.

FSV implementation involves interpolating the two datasets to be compared over a common window (often common frequency range or time window) to ensure that the data points to be compared are coincident. This approach ensures that like is being compared with like and will not

Design and implementation of patch antenna

affect the overall results unless the data are severely under sampled. It must be remembered that the purpose of the FSV is to mimic a visual comparison, and so long as any interpolation does not produce results that are clearly visually different from the original data, the approach is perfectly acceptable.

As noted above, the actual comparison is based on decomposing the original data into trend information and feature information. Hence, the next step is to Fourier Transform the data and filter the transformed data to separate out the lower and higher frequency portions. These “high” and “low” portions are then transformed back into the original domain. Combinations of these filtered datasets and their derivatives are used to compute the ADM and the FDM, which can be combined into the GDM.

In order to provide a close agreement with visual assessment, FSV is a heuristic technique, with a number of weighting factors and constants that have been obtained by a process of analysis against visual interpretation.

FSV method show that a straight forward mathematical approach can be used to obtain a comparison between two sets of data that is consistent with the interpretation of a group of experts.

In order for a mathematical technique to succeed in performing this function, a number of applicability tests were proposed. The assessment of the FSV method is very positive, suggesting that it is close to achieving these tests.

- 1) *Implementation of the validation technique should be simple.* The FSV method has been implemented in Java, and using Matlab, it has also been implemented as a MathCad worksheet. Other than a Fourier Transform, no esoteric mathematics or convoluted programming is required.
- 2) *The technique should be computationally straightforward.* The FSV method has been run on Pentium II-based PCs (and higher).
- 3) *The technique should mirror human perceptions and should be largely intuitive.* Results to date are very encouraging and will be reported further in Part II.
- 4) *The method should not be limited to data from a single application area.* Although not discussed in this paper, the FSV method has been successfully used with DNA “fingerprint” data.
- 5) *The technique should provide tiered diagnostic information.* The output ranging from the GDM (single value) through to the point-by-point analysis and the confidence limits suggest that tiered diagnostics are available.
- 6) *The comparison should be commutative.* It can be seen from the mathematics involved that the approach is commutative.

The method, seems to come close to providing the bridge between simple data analysis and the more subtle, but more desirable, human interpretation.

5. Project - Design and implementation patch antenna : Inverted F-Antenna (IFA) on 868 MHz.

5.1. General information.

This chapter describes my projected antenna. This is a patch antenna and working on frequency 868 MHz ($\lambda = 0.345$ m), feed by microstrip line with input impedance 50Ω . Shape of radiation part is IFA (*Inverted-F Antenna*). Antenna is produced on PCB (*Printed Circuit Board*). Used dielectric is FR4 with thickness 1.53 mm. Permittivity of FR4 is $\epsilon_r = 4.5$. The dimensions of antenna are written below on Figure 5.1 and Table 5.1. Main idea of shape of antenna was taken from Texas Instruments Design Note DN023. Power supply is 3 V.

Dimensions in this document is a final. Before that, there was a many tries of changing dimensions from original Texas antenna. Compare with Texas Instruments, radiation stripe is cut off almost 20 % of all length. This operation was necessary to match frequency. Second problem was in microstrip. When frequency was right, the S_{11} parameter was on -7 dB and to increase that, the microstrip have is longer 5 mm then original from Texas. Also via is added, because in original design short between F-shape radiation part and ground plane had different solution appear from construction of PCB. Thickness of FR4 was also different, but that was a little problem. The last problem is in feed point. That appear also from construction and to get done with it, We added a coaxial wire which sticking out of PCB.

In our example, IFA have omni radiation. To manipulate frequency You have to change length of radiation stripe. If You increase length of this stripe, the frequency is going up, when You cut of strip, frequency goes down. To make better S_{11} parameters You must manipulate length of microstrip. You can't forget about permittivity of used dielectric. In our case manufactured antenna is better than simulated. One of reasons of this is attached solid coax to antenna. This probably make batter S_{11} parameter about 1.5 dB. Wires plugged in to antenna which is working on UHF, must have a solid attached to case of device to avoid a frequency surfing.

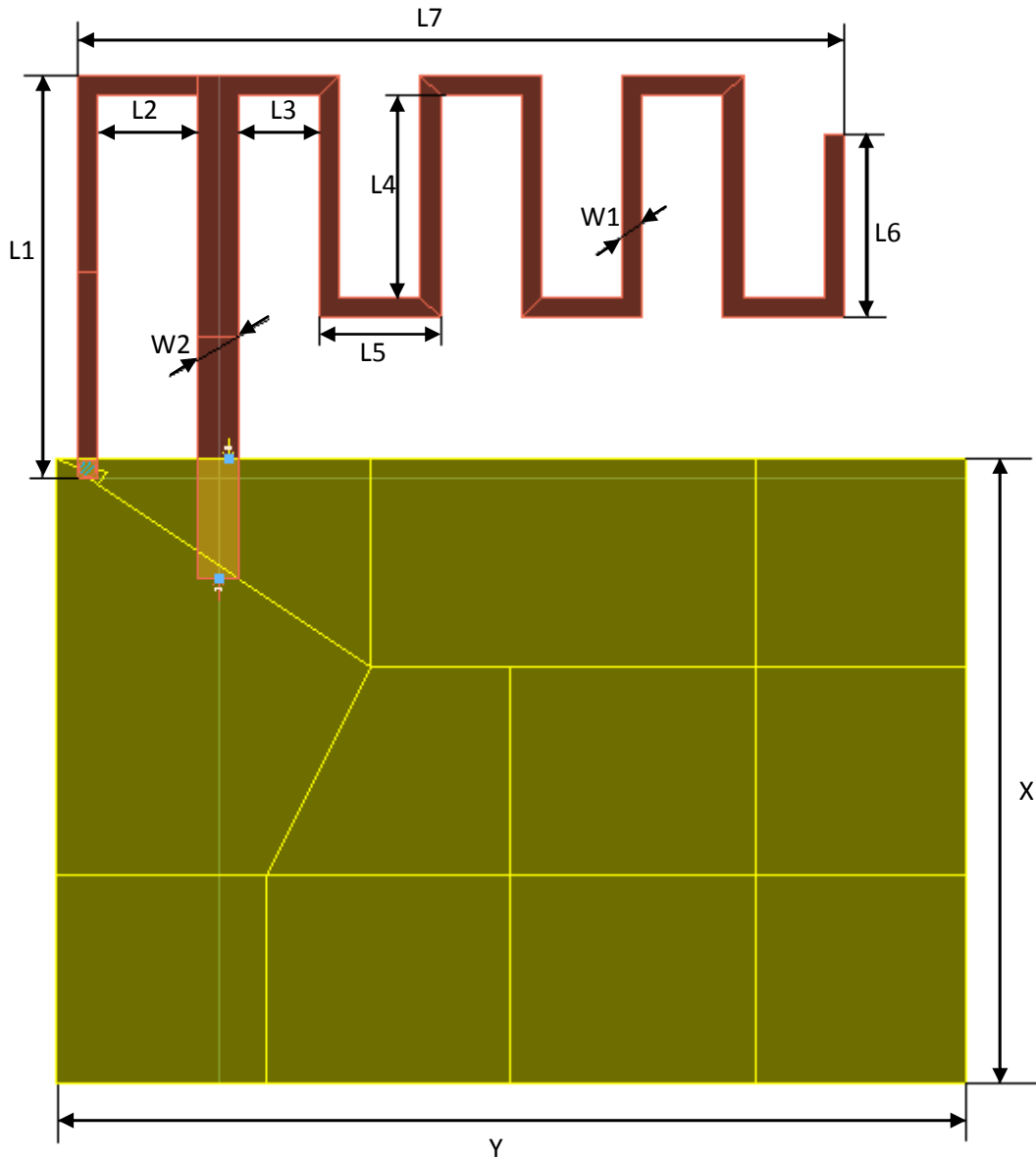

Figure 5.1. Antenna dimensions.

Table 5.1. Antenna dimensions.

L1	20 mm	X	31 mm
L2	5 mm	Y	45 mm
L3	4 mm	W1	1 mm
L4	10 mm	W2	2 mm
L5	6 mm		
L6	9 mm		
L7	38 mm		

On Figure 5.1 red color define the top layer (radiation part), yellow define the ground plane and blue striped circle is a via. Length of feed microstrip is 25 mm.

Design and implementation of patch antenna

Figure 5.2 shows substrate taken from ADS. "cond" represents top layer, "cond 2" represents bottom layer (GND), "hole" represents via. All conductor layers were made from cooper with thickens 45 μm (also during the simulations in ADS).

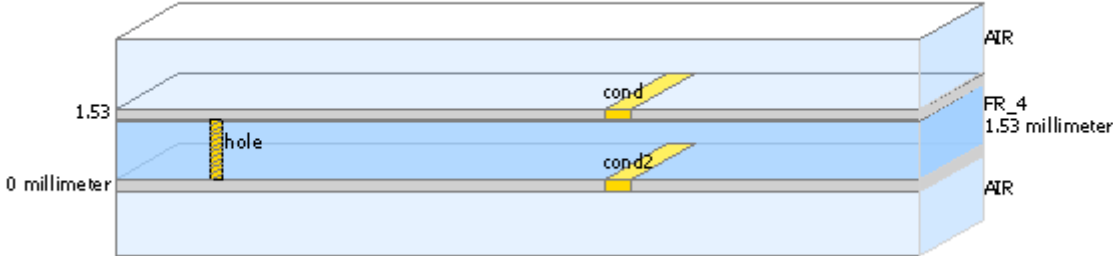

Figure 5.2. Substrate.

Produced antenna shown in Figure 5.3. As You can see, the feed point is made by coaxial wire with plug.

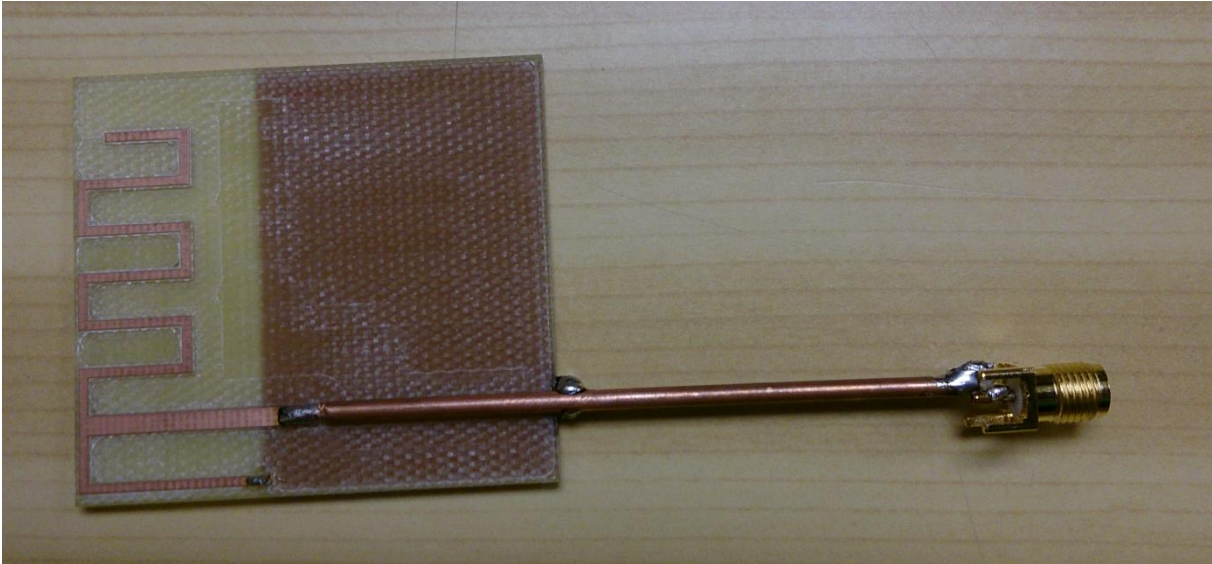

Figure 5.3. Produced IFA.

5.2. Momentum microwave simulation.

In this subchapter will be presented a simulations taken from ADS - S_{11} parameters, far fields, radiation pattern.

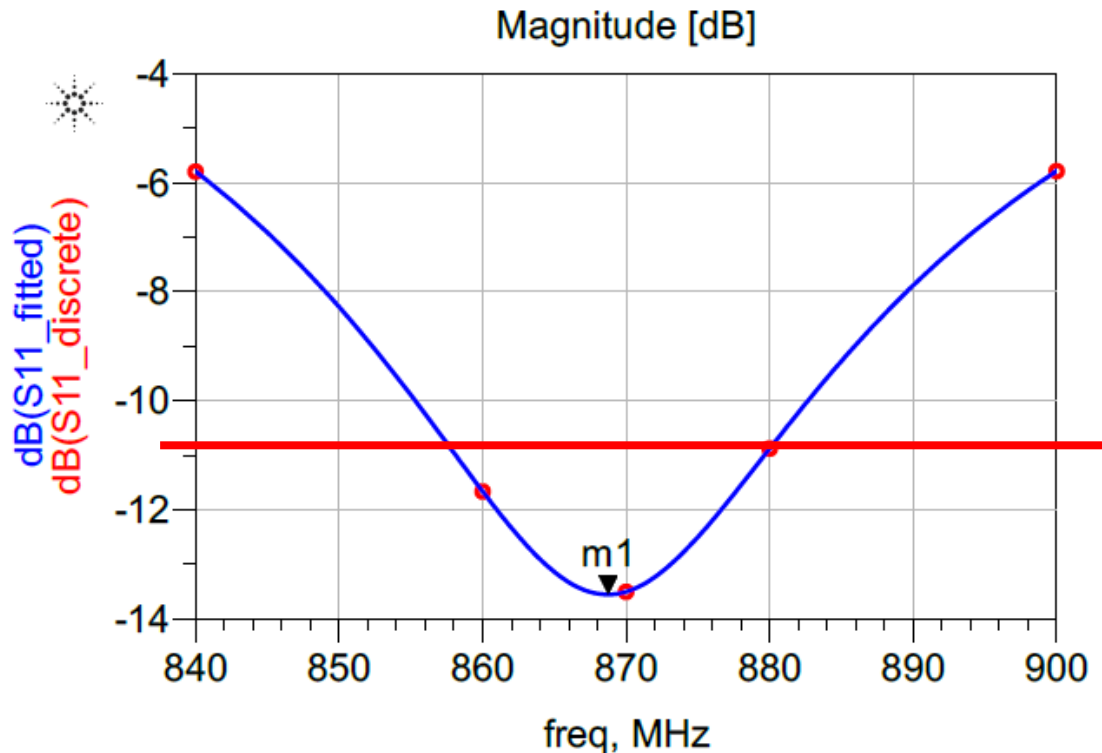
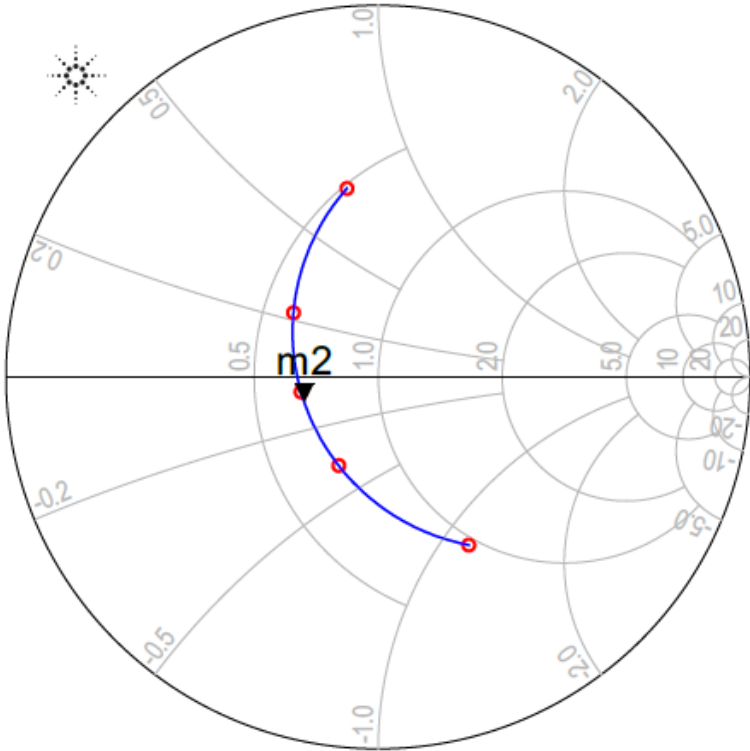

Figure 5.4. S_{11} parameters.

On Figure 5.4 you can see simulated S_{11} parameters of projected antenna. This simulation goes down below -10 dB on right frequency 868 MHz, that means the antenna is correct (fitted). "m1" point is placed on 868 MHz and amount -13.55 dB. Figure 5.5 shows our IFA on Smith chart. Point "m2" is placed on frequency 868 MHz. Momentum microwave simulation in ADS was very satisfy, because as You can see point "m2" is close to center of Smith chart.

Figures 5.6, 5.7, 5.8, 5.9 show antenna Gain, Directivity, Efficiency and Power radiation. Gain is low, because this antenna radiate in almost every direction. Radiation patters shown in figures 5.10 and 5.11. Gain of our antenna is about 0.3 dB, directivity = 2.13 dB, efficiency = 65.65 % and power radiation = 14 mW. From radiation patter is result that is a omnidirectional antenna.



freq (840.0MHz to 900.0MHz)

Figure 5.5. Simulated IFA on Smith chart.

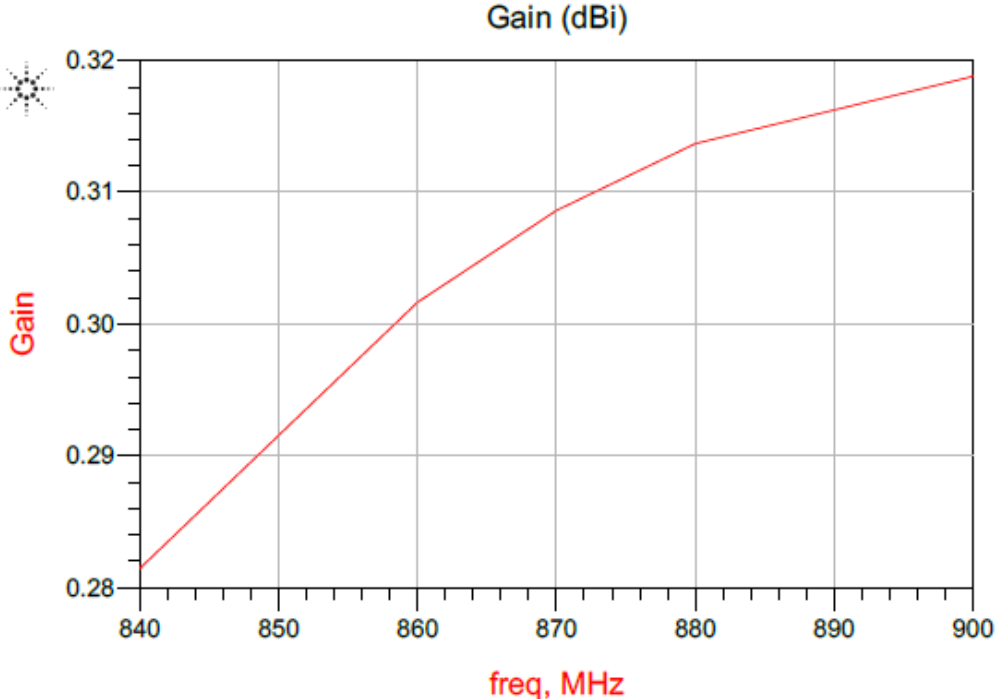

Figure 5.6. Gain.

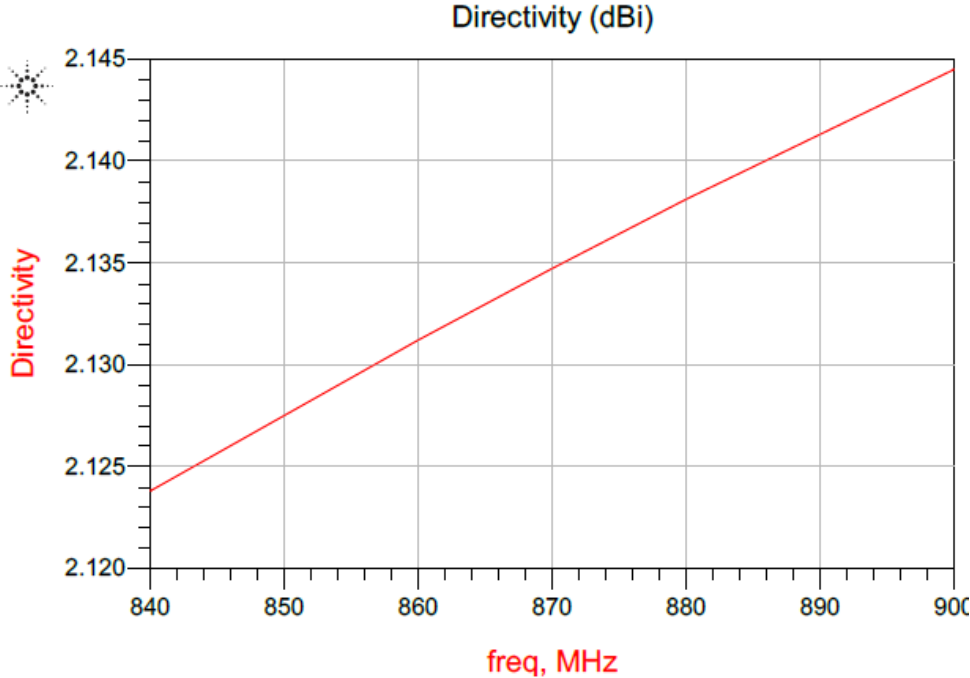

Figure 5.7. Directivity.

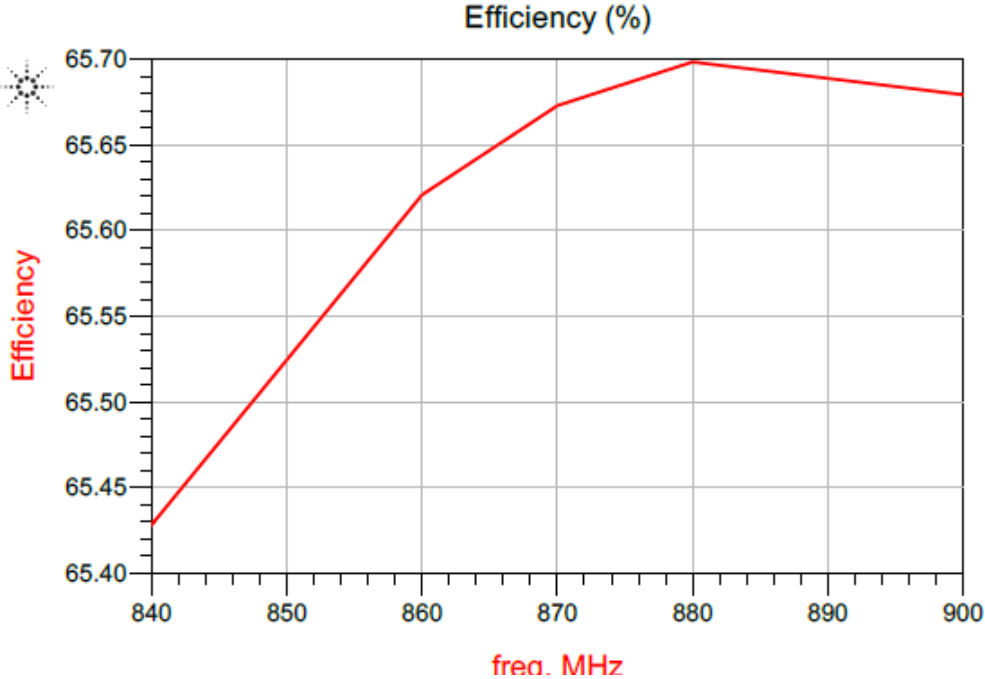

Figure 5.8. Efficiency.

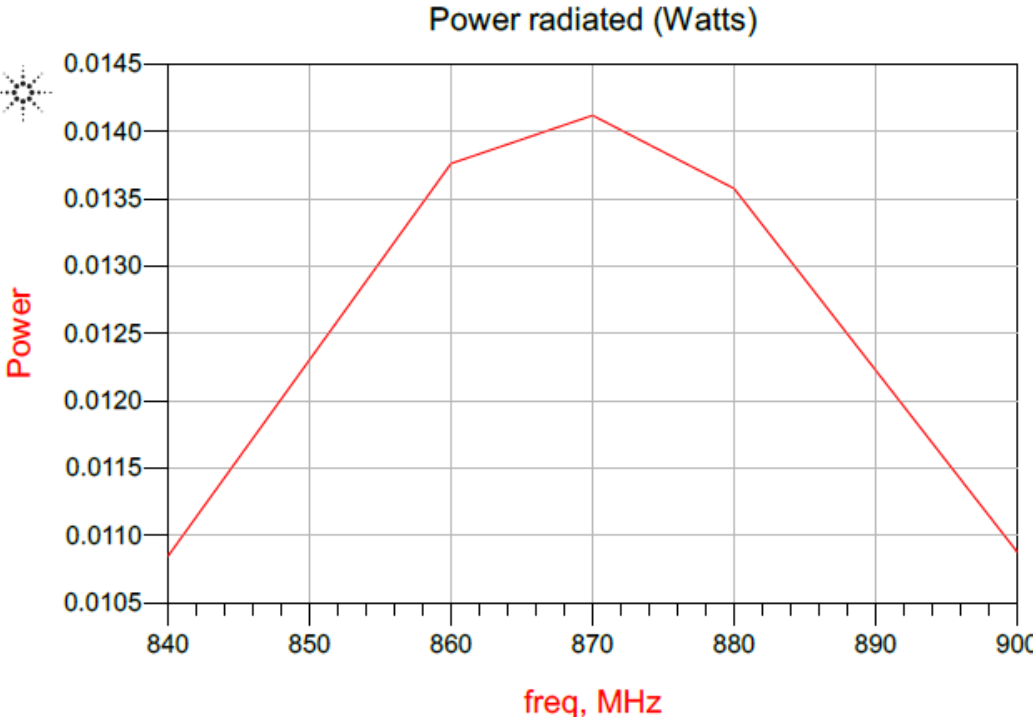

Figure 5.9. Power radiation.

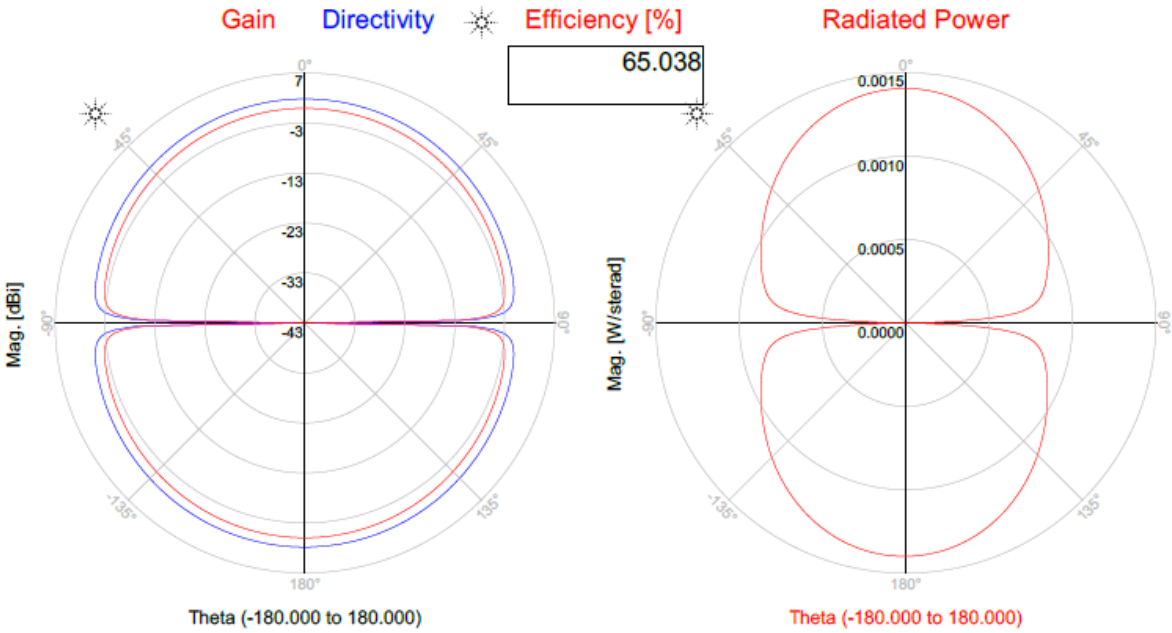

Figure 5.10. Radiation pattern - part 1. $\phi=0^\circ$

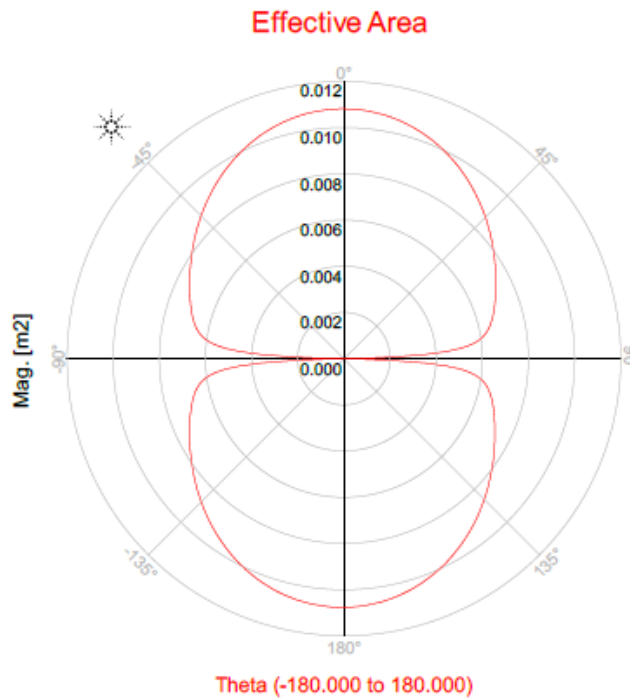

Figure 5.11. Radiation pattern - part 2. $\varphi=0^{\circ}$

5.3. Measurements.

This chapter talks about real measurements of produced antenna. There is unusual situation, because produced antenna is over 2 times better than simulated. When You look on Figure 5.12 and 5.13 You can see that produced antenna is excellent. Gain is on level about - 30 dB and the smith chart shown in Figure 5.13 told that our frequency 868 MHz is near by the middle of graph. On Figures 5.14 and 5.15 You can see comparing of Momentum simulation results with real antenna. That give us over 60 % of "fair" and "good" result.

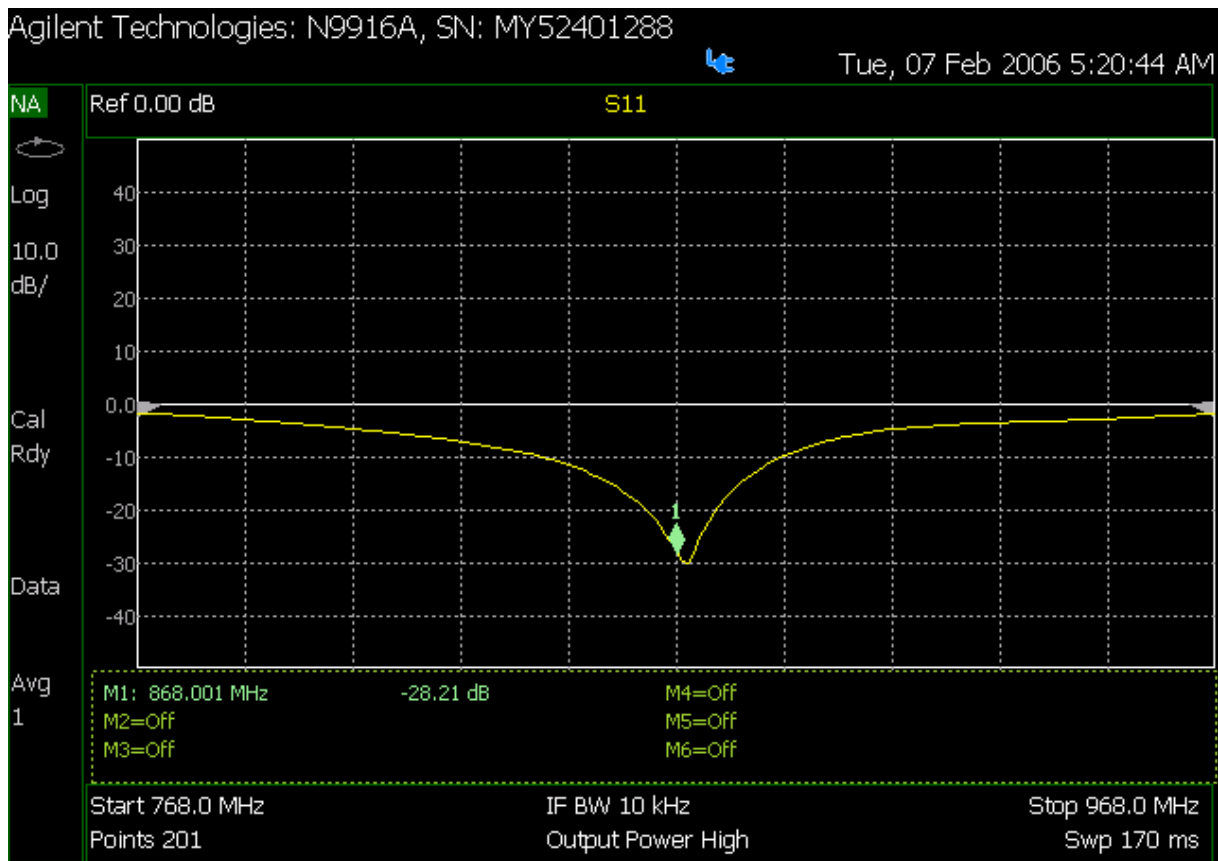

Figure 5.12. S_{11} parameter of produced antenna.

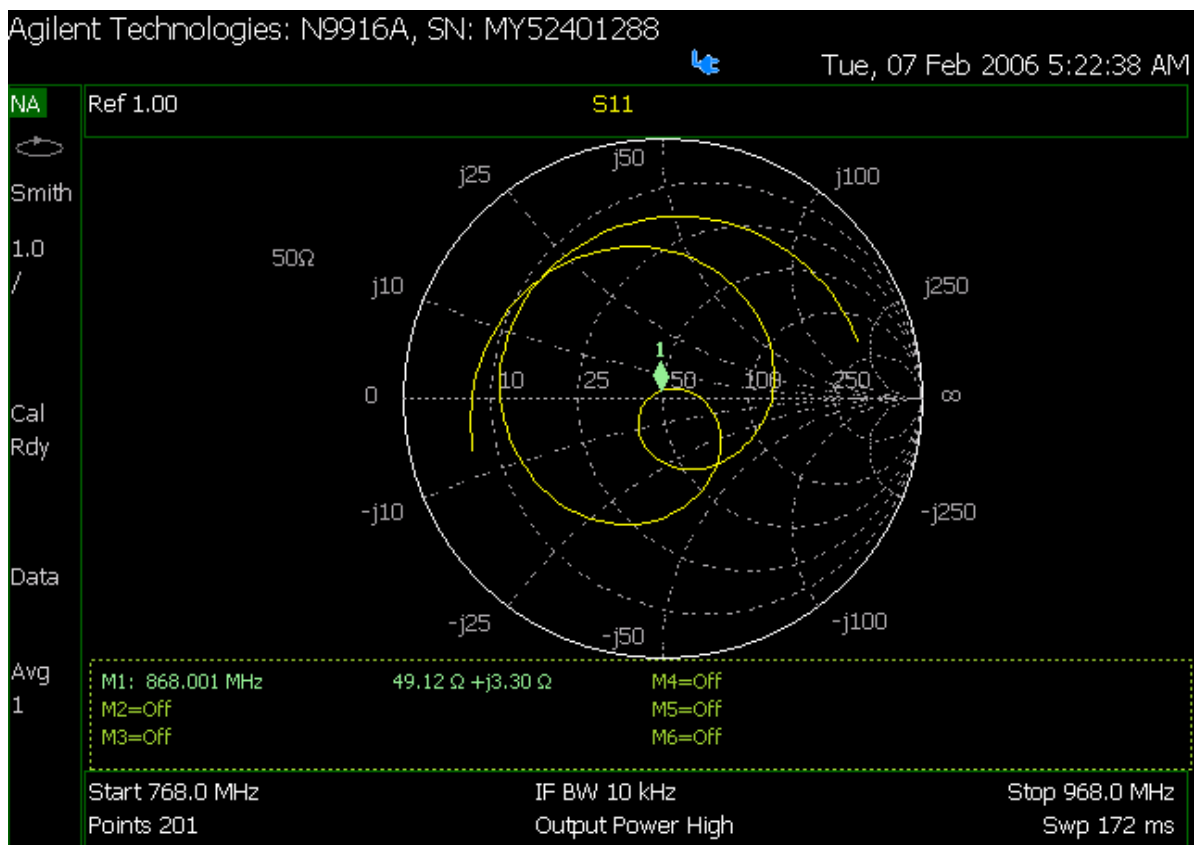

Figure 5.13. Smith chart of produced antenna.

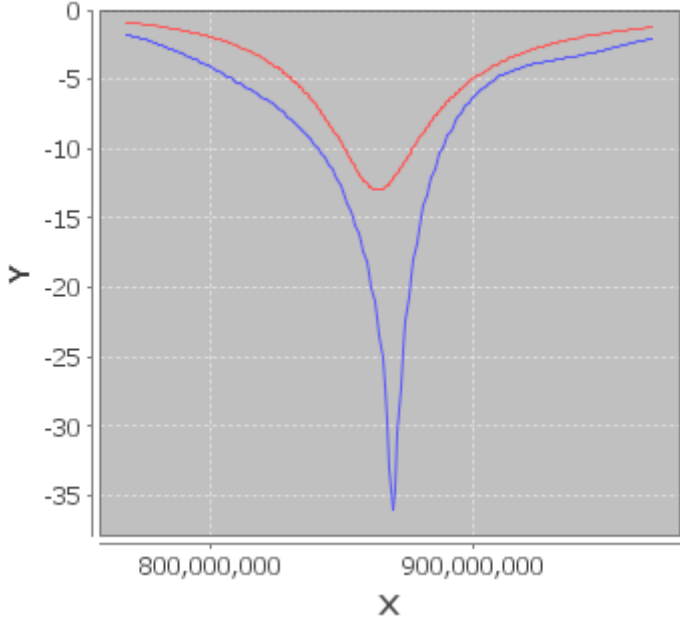

Figure 5.14. Comparison of Momentum Microwave simulation from ADS (red line) and real measure (blue line). Y axis is in dB and X axis is frequency [Hz].

To compare this two data, simulated from ADS and measurement of real IFA, I used FSV algorithm.

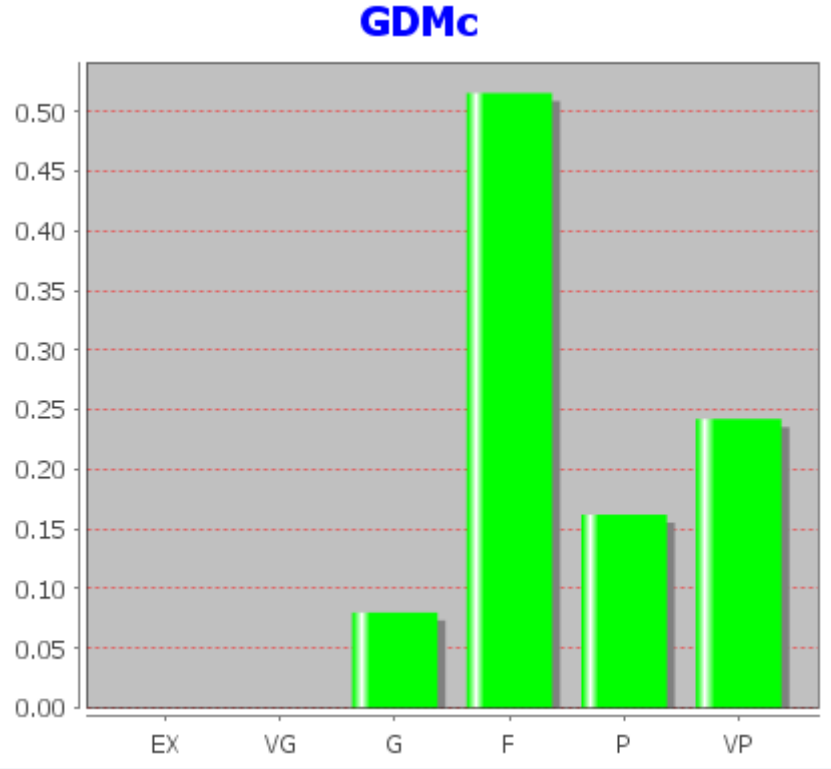

Figure 5.15. GDM from FSV (Momentum Microwave sim and real measurements).

6. Conclusion.

Patch antennas in this time is really popular. Almost every mobile and home electrical device have microstrip antenna, beginning from cell phones, ending on TV's and laptops. The biggest advice is a dimensions of patch antennas. They are very small and We can put them almost everywhere.

To summarise all results, the best tool to simulation antenna is Momentum microwave from ADS. That simulation give the most similar results to produced antenna. To mach frequency and to take the best S_{11} parameters it is necessary to manipulate length of radiation stripe and microstrip close to feed point. Final result are better than an original concept from Texas Instruments, that means in changing prototype we achieve success.

7. References.

- [1] P. Dębicki: *Wprowadzenie do teorii anten i szyków antenowych*. Akademia Morska w Gdyni 2012
- [2] J. Wiley & Sons: *Antenna Theory*. John Wiley - Interscience 2005
- [3] J. Szóstka: *Fale i anteny*. WKŁ 2006
- [4] R. Kubacki: *Anteny mikrofalowe*. WKŁ 2009
- [5] Politechnika Gdańska: *Anteny o sterowanej wiązce w technice radarowej*. WKŁ 2012
- [6] F. Kervel: *Design Note DNO023 - 868 MHz, 915 MHz and 955 MHz Inverted F Antenna*. Texas Instruments 2011
- [7] IEEE Docs: *FSV for Validation of CEM*. IEEE 2006
- [8] www.agilent.com
- [9] www.antenna-theory.com