

Universitat Politècnica de Catalunya

Escola Tècnica Superior d'Enginyeria Industrial

**CONTROL DE MOVIMIENTO DE UN ROBOT MÓVIL
OMNIDIRECCIONAL**

Directors :

Prof. Luis Basañez Villaluenga

Prof. Orestes Miquel Mas Casals

Author:

Luca Magnabosco

September 2012

Resumen

Los robots móviles Omnidireccionales son cada vez más populares debido a su mayor movilidad. Comparados a los más comunes “car-like robots”, tienen una agilidad superior para moverse hacia cualquier posición y alcanzar simultáneamente cualquier orientación deseada.

El propósito del proyecto es controlar la plataforma omnidireccional del IOC, que constituye la base del *Barcelona Mobile Manipulator* y que ha sido construida con la colaboración del Departamento de Ingeniería Mecánica de la UPC. El objetivo es controlar coordinadamente los tres motores que mueven las ruedas omnidireccionales utilizando el protocolo EtherCAT.

El desarrollo del proyecto requiere: a) el estudio de la comunicación por EtherCAT entre el PC de control y los controladores de motores que disponen de un módulo EtherCAT; b) el desarrollo de un master EtherCAT apto a las necesidades de utilización de la plataforma; c) el desarrollo de software tanto para el control en tiempo real por Joystick, como para el seguimiento de una trayectoria planificada.

El software se ha desarrollado utilizando Orocos con el fin de obtener una implementación más sencilla y eficiente de la aplicación, mientras que la librería SOEM se ha utilizado para controlar la comunicación EtherCAT.

Abstract

Omnidirectional mobile robots are increasingly popular due to their enhanced mobility. Compared to the more common car-like robots, they have the superior agile capability to move towards any position and attaining simultaneously any desired orientation.

The project's purpose is to control the omnidirectional platform of the *Barcelona Mobile Manipulator* (BMM) built with the collaboration of the Mechanical Engineering Department of the UPC. The idea is to control the three motors that move the omnidirectional wheels using EtherCAT protocol system.

The development of the project requires: a) the study of the communication by EtherCAT between the PC controller and motors' drivers that are provided with an EtherCAT module; b) the development of an EtherCAT master suited to the platform utilization; c) software developing for both the real-time control by Joystick and the tracking of a planned trajectory.

The software has been developed using Orocos to allow a simple and efficient implementation of the application, as well as real-time performance, while SOEM library has been used to control EtherCAT communication.

Contents

Resumen	3
Abstract	5
Preface	9
1 Introduction	11
2 Background	13
2.1 Omnidirectional Platforms	13
2.2 Omnidirectional wheels	15
2.3 EtherCAT master	16
3 Motivation	19
4 Objectives	21
5 Involved Hardware	23
5.1 Spherical omnidirectional wheels	23
5.2 Motors	24
5.3 Platform	25
5.4 Joystick	26
6 Involved Software	29
6.1 SOEM	29
6.2 Orocos	39
7 Orocos EtherCAT communication components	47
7.1 Orocos EtherCAT master	47
7.2 Orocos EtherCAT slaves	53

8	Orocos control components	57
8.1	Joystick component	58
8.2	Trajectory Generator component	59
8.3	Platform component	62
9	Environmental Analysis	75
10	Costs Analysis	77
11	Results	79
12	Conclusions	85
13	Future Work	87
A	EtherCAT	89
A.1	EtherCAT introduction	89
A.2	EtherCAT terminology	92
A.3	Message syntax	99
A.4	EtherCAT commands	102
B	User Manual	105
C	TaskContext Example	115
D	CD contents	119
	Bibliography	121

Preface

Omnidirectional mobile robots have the ability to move concurrently and independently in rotation and movement in the plane and this fact is giving them a growing popularity not only in robotic competition but in the industry too. In the last decades the majority of robotic research has focused on either mobile platforms or manipulators, but nowadays one of the new challenges is to combine the two areas into systems which would have both high mobility and the ability to manipulate objects.

The growing interest is justified not only by the usually growing level of automation in the industry field but by the service robotic too. Because of the demography of most western countries, the service robotics will have more and more importance in the next years as the service sector will suffer an increasing demand while the supply of human operators will be limited. The platform we are going to present and control in this work consists of a Kuka lightweight Robot mounted on an omnidirectional base. The target is a mobile manipulator that has a relative small footprint and is highly maneuverable.

This work wants to obtain the result of a working program that not only communicates by EtherCAT with the motors, performing the needed configuration, but that should also be able to allow different control options such as controlling real-time in open loop with a Joystick or tracking a predefined trajectory. A possible algorithm of obstacle avoiding, performing the above operations, will be described too.

The EtherCAT choice deals with the different methods that exist to connect I/O devices, in general, and servodriver, specifically, to a computer to ensure a highly synchronized level of control. One way would have been to put in the computer a single card for every motor but the EtherCAT choice was made to avoid problems due to slots requirements in the computer and mainly because of the high synchronization that this protocol ensures if used with the internal mechanism of DC clock.

Chapter 1

Introduction

The platform that this work aims at controlling, is an omnidirectional non holonomic mobile platform that bases its functional principle on three pairs of omnidirectional wheels developed by the Mechanical Engineering Department of the UPC. The platform has been dimensioned to be equipped with a Kuka lightweight robot with the purpose to be totally autonomous, therefore the space for the Kuka's controller and for the batteries has been taken into account. The total weight of the platform without the batteries is about 70 kg. It will be moved by three direct-drive servomotors that are capable of high torques and therefore don't need reduction. This has been planned to avoid the play between gears without using highly expensive gearbox.

The communication between the user and the platform will be performed by Wi-Fi while the on board PC will communicate with the servo drivers and with the Kuka controller using wired Ethernet connections. For the communication between the PC controller and the servo drivers the EtherCAT protocol will be used.

This project aims at obtaining a working program that ensures the possibility to control the platform base at least every millisecond and that should constitute the base for the future development of control algorithms that will control both the base and the Kuka robot together to interoperate between robots.

The work is structured to guarantee a base software package for motors' control by EtherCAT while an upper part of the software will be developed to check the effectiveness of the base software and the applicability of various controller models.

The software that deals with EtherCAT has been designed having transparency in mind. The so called EtherCAT master, represented by the program running in the PC that takes care of the communication, has been developed to be used with different motors or generally different EtherCAT slaves requiring just a minimal effort to program few lines of code that depends on the

specific model that is going to be used. This has been done to allow a simple portability of the code, in case of a motor change, for the next generation platform that will be developed based on the acquired experience of this one. Moreover such a kind of master could result useful in case sensors, that are EtherCAT capable, are going to be integrated in the project.

Chapter 2

Background

2.1 Omnidirectional Platforms

Nowadays the interest of the Industries around mobile robotics is growing mainly because of two reasons:

- these platforms are particularly useful in service robotics, an application of robotics that is increasing day by day.
- these platforms could enhance the benefit of automating an industrial process by adding to a manipulator the possibility of moving it around its work space taking advantage of the omnidirectionality to maintain the space required for the movement as smaller as possible.

Few companies have recently developed platforms mainly for mobile manipulators. Among them mainly three options have been examined to verify if one of them could satisfy our needs.

Kuka platform

Kuka sells an omnidirectional platform (fig. 2.1) that can be equipped with various kinds of arm. It uses four omnidirectional wheels with peripheral rollers. At the moment only the smallest model [length: 580 mm, width: 380 mm, height: 140 mm] is available and it has a payload of 24 kg and a maximum speed of 0.8 m/s [22].



(a) Kuka YouBot platform.



(b) Kuka OmniRob platform.

Figure 2.1: Kuka mobile manipulators

CoroBot platform

CoroWare makes available two platform configurations so the user can choose between a 4WD skid steer base or 2WD differential drive base. As it can be seen (fig. 2.2), they do not use omnidirectional wheels, therefore such platforms aren't omnidirectional. Their characteristics are: dimensions [length: 304.8 mm, width: 330.2 mm, height: 254 mm], payload of 2.268 kg and a speed of 0.45 m/s.

NEOBOTIX platforms

Neobotix offers a range of standard platforms, among them 2 series are interesting for purposes similar to what we have: 500-line and 700-line. The MPO-500 (fig. 2.3) measures [length:986 x width:692 x height:409], it has a payload of 50kg/120kg and a maximum speed of 0.8m/s. The MPO-700 (fig. 2.3) measures [length:711 x width:497 x height:431], it has a payload of 80kg and a maximum speed of 0.8m/s. The last one uses 4 Steering wheels while the previous one is equipped with four omnidirectional wheels with peripheral rollers.



(a) 4WD skid steer base.

(b) 2WD differential drive base.

Figure 2.2: CoroBot platforms

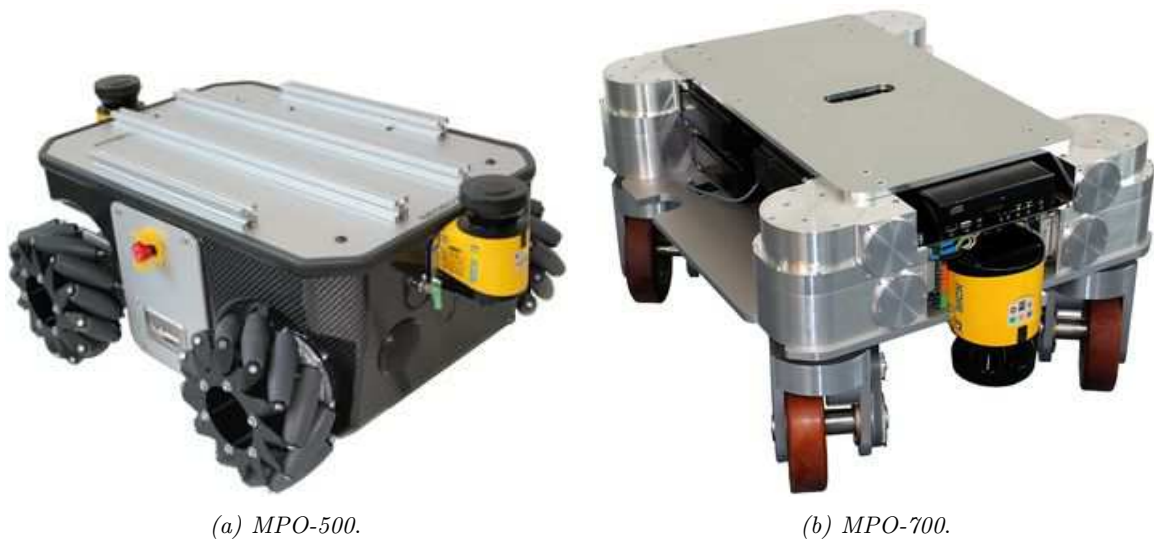

(a) MPO-500.

(b) MPO-700.

Figure 2.3: NEOBOTIX platforms

2.2 Omnidirectional wheels

As it has been shown, various omnidirectional platforms that are available on the market use omnidirectional wheels of various kind with different configurations. But what is an omnidirectional wheel?

An omnidirectional wheel is a wheel with directional slip, that is a mechanical device to simulate a link sliding to the ground in a particular direction fixed to the platform or vehicle in question.

The tangential strength between the wheel and the ground is then perpendicular to the direction of sliding. In the mobile and automated guided vehicles that use this type of wheels there are basically two constructive solutions (fig. 2.4).

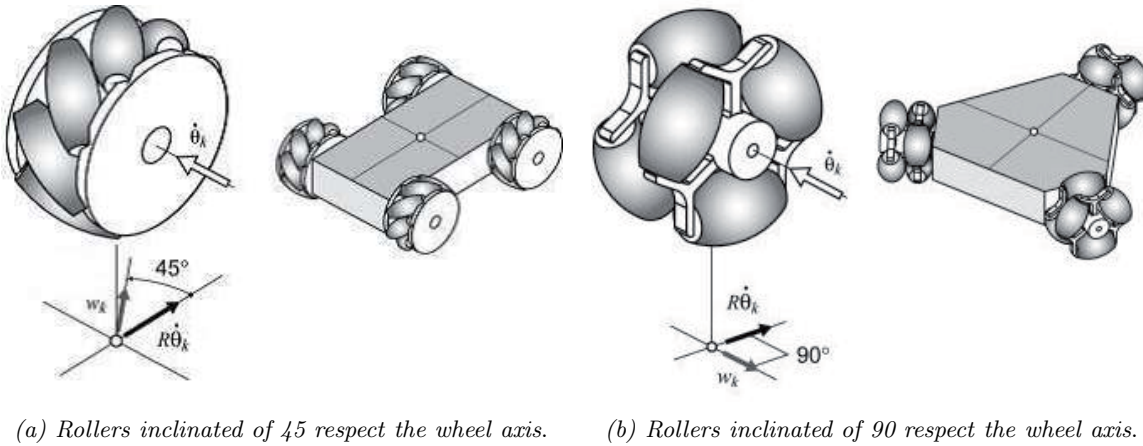

Figure 2.4: Platforms with peripheral rollers wheels.

The omnidirectional wheels' working principle is based upon the fact that rollers can rotate freely around its axis, so that in every moment the roller touches the ground while rolling freely, to simulate sliding, in the direction normal to its axis, therefore preventing from slippage in the axial direction. Then, controlling the rotation speed of each wheel by its independent motor, the three platform's movement degrees of freedom can be controlled.

In this work we are going to control an omnidirectional platform equipped with three omnidirectional wheels whose innovative design has been developed by the UPC Mechanical Engineering Department. Their design will be explained in section 5.1.

2.3 EtherCAT master

An EtherCAT master is necessary to control the EtherCAT slaves on the network by using the master-slave principle. It is possible to implement an EtherCAT master to every processing unit with a standard Ethernet controller. The EtherCAT master is usually implemented on a (industrial) PC running a real-time operating system to provide real-time guarantees.

EtherCAT masters

There are many EtherCAT master drivers available for different operating systems and hardware platforms, e.g. Windows, Linux, QNX, PLC's etc. For Windows the most known one is maybe

TwinCAT by Beckhoff, while for Linux there are IgH EtherCAT Master and Simple Open EtherCAT Master (SOEM).

TwinCAT

TwinCAT can't be considered only as an EtherCAT master as it provides a rich environment of tools that are oriented to turn a PC into a real-time controller as explained in the TwinCAT site.

The Beckhoff TwinCAT software system turns almost any compatible PC into a real-time controller with a multi-PLC system, NC axis control, programming environment and operating station. TwinCAT replaces conventional PLC and NC/CNC controllers as well as operating devices with:

- open, compatible PC hardware
- embedded IEC 61131-3 software PLC, software NC and software CNC in Windows NT/ 2000/ XP/ Vista, Windows 7, NT/ XP Embedded, CE
- programming and run-time systems optionally together on one PC or separated
- connection to all common fieldbuses
- PC interfaces support
- data communication with user interfaces and other programs by means of open Microsoft standards (OPC, OCX, DLL, etc.)

It can be considered extremely complete but our choice will be oriented to an open-source system and drivers so we preferred to evaluate the two other possibilities.

EtherLab

IgH EtherCAT Master is an EtherCAT master library that is written in C by the Ingenieurgesellschaft IgH. This EtherCAT master library works as a Real Time for the Linux 2.6 kernel and comes with specific EtherCAT-capable drivers for several common Network Interface Controllers (NIC).

SOEM

Simple Open EtherCAT Master (SOEM) is an EtherCAT master library that is completely written in C and is targeted for any Linux operating system as a user space application. An important

advantage of this EtherCAT master library is that it doesn't provide limitations on the applied design architecture.

Final choice

Finally, for this project, SOEM is preferred over the EtherLab Master because it can be used as a user space application instead of implementing it as a kernel space application like IgH does, therefore it is more portable and can be implemented without difficulties in any GNU/Linux with real-time extensions such as RTAI, Xenomai or RT-Preempt but also in another POSIX compliant real-time operating system like QNX. This is not easily realizable with IgH because it is completely implemented in Linux kernel space therefore it contains much kernel specific source code.

Another important reason that favours our choice of SOEM¹ is also that it is portable between different computers running Linux, without hardware compatibility problems, because all arbitrary NICs that are able to connect to a RAW socket can be used without any modification. On the contrary EtherLab always needs a special designed EtherCAT driver for each different Ethernet controller and therefore limits the compatibility between computer systems with different hardware.

¹The SOEM library will be described in chapter 6.1.

Chapter 3

Motivation

The present work is focused on the development of a software package that should allow the basic control of the new mobile omnidirectional platform of the IOC. The work starts with the basic configuration of the motors and takes care of all the process till the trajectory tracking passing through the problematic concerning EtherCAT communication with the servo drivers.

This work intends to represent the first step in controlling the omnidirectional base of the Barcelona Mobile Manipulator, that has been designed to be equipped with the Kuka Lightweight Robot that the institute already has, in the framework of a greater project, whose target is the collaboration of more than a mobile manipulator to move objects.

The use of Orocos middleware is intended to allow a simple and efficient implementation of the application. Moreover it has been useful to ensure real-time performance to the whole code.

The development of a new Orocos EtherCAT master using SOEM has been decided to allow an easier slave/motor configuration for the next users.

The implementation of a trajectory generator has been decided, even if in the Orocos environment is already present a trajectory generation functionality using KDL, because this last one fits better to arm-motions and does not present any competitive advantage in trajectory generation for an omnidirectional platform.[7]

Chapter 4

Objectives

The main objective of this work is to make a basic application which controls the mobile omnidirectional platform using as references speeds or torques and that allows real-time performance. To achieve this objective, this work is divided into three modules:

- **EtherCAT communication module**

The first problem that has to be solved is the communication between the controller PC and the servo-motors. As it will be explained these servo-motors have drivers equipped with an EtherCAT module. Therefore the main objective of this module is to transmit data through EtherCAT protocol ensuring a high level of synchronization. This objective can be divided into three parts:

1. Ensuring a fast and easy configuration of the motors with the desired parameters. To do that SDO EtherCAT messages will be sent.
2. Ensuring a fast communication of both motors' reference and actual data using EtherCAT PDOs communication.
3. Ensuring a high level of synchronisation of the data toward and backward the motors using the synchronisation mechanism integrated in EtherCAT and called DC clock.

- **Platform's control module**

The second problem that has to be faced is how the motors have to be moved to obtain a certain movement of the platform. To solve it, the software has to integrate the kinematic matrices of the platform.

To verify the good accuracy both in positioning and in trajectory tracking that this platform can achieve using spherical wheels, various controllers, based only in the position read from the encoders, are going to be implemented. They are intended to be used, in the next future,

integrating the encoders' information with other position information that will be provided to achieve a precise odometry of the platform.

- **Movement references generation module**

The software also requires the development of a part that could generate the position/speed reference that the platform has to follow. The program that has to be developed has to exploit the superior maneuverability of this omnidirectional platform. The trajectory generation has to be faced in a different way, compared with the habitual car-like platforms, as in our case a trajectory could be any differentiable function.

The objective is to obtain a real-time trajectory control using a Joystick and the possibility of obtaining easily a trajectory that passes through path points that the user can define before the runtime.

Chapter 5

Involved Hardware

In this part we are going to describe the hardware used to carry out the project.

5.1 Spherical omnidirectional wheels

The IOC platform is equipped with a new kind of omnidirectional wheel developed by the Mechanical Engineering department of UPC (fig.5.1).

In a wheel of this type there are two components of the rotation angular speed: a component is in horizontal direction and, along this one, the platform is controlled by the drive motor, the other component is a free rotation having perpendicular direction to the first. This second rotation simulates sliding in the horizontal direction, normal to the axis of rotation.

This new kind of omnidirectional wheel has been preferred mainly because of these two reasons:

- Peripheral rollers wheels, like the ones shown in figure 2.2, present a higher level of uncertainty in the location of the contact point of each roll with the ground, as it depends on the angle turned by the wheel. This affects the platform's odometric accuracy. Spherical wheels don't present this problem because each pair touches the ground alternately.
- Constructively, the peripheral rollers wheels are more complex, requiring more elements: rollers, shafts, bearings, etc.. Besides the rollers bearings have necessarily to be small for space reasons and this limits the capacity of the wheels. By contrast the spherical wheels are more simple and have more interior space, allowing to use larger bearings.

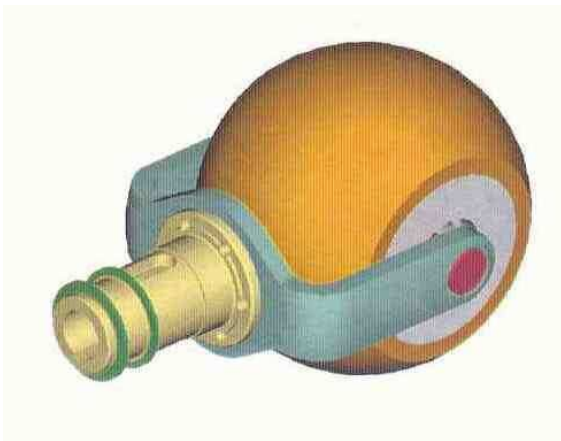

(a) Spherical wheel.

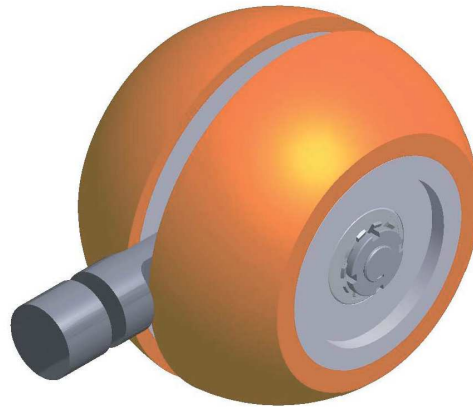

(b) Spherical beparted wheel.

Figure 5.1: Spherical wheels possibilities.

5.2 Motors

The motion hardware that the platform is equipped with is represented by:

- 3 servopacks Yaskawa model SGDV-2R8AE1A soft version 0021
- 3 option modules SGDV-OCA01A (EtherCAT) with software version 0002
- 3 servomotors Yaskawa model SGMCS-07B3C11 with an absolute encoder UTSBI-B20HB11E with the resolution of 1048576 pulse/rev and software version 0007

The three servomotors are direct-drive that means they are directly coupled to the load without a mechanical transmission such as a gear (fig. 5.2). The EtherCAT (CoE) Network Module does not support EtherCAT Read/Write commands (APRW, FPRW, BRW,LRW), [8] this characteristic is important to understand further explanations.

This choice has been done to ensure a high level of odometry¹ precision. The three servomotors have a rated torque of 7 Nm while the maximum torque is of 21 Nm as it can be seen in figure 5.3. Using the servopacks it's possible to control the motors with 3 kinds of reference signal: position, speed and torque. Moreover, by setting the internal parameter, called *operation mode*, it's possible to switch between the different reference signals, while the motor is running, and to set for every reference if it is used to define a profile or if it has to be applied as fast as the motor can operate in a synchro-way.

¹As odometry precision we mean the position precision in function of the wheels' angle.

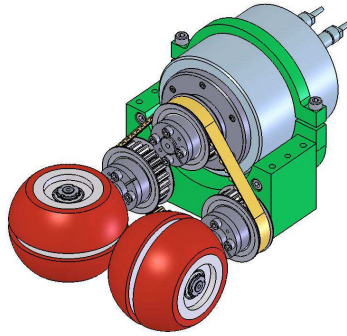

Figure 5.2: Motor directly coupled to the wheels pair

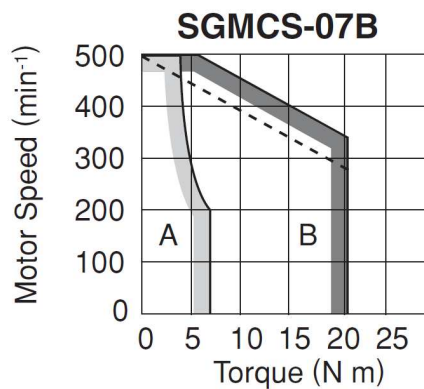

Figure 5.3: Motor's characteristics: A) Continuous Duty Zone B) Intermittent Duty Zone

5.3 Platform

The platform, that this work has the purpose to control, has been developed and dimensioned to be autonomous and to be equipped with the Kuka Lightweight Robot, therefore this prototype has a medium footprint to have the space to integrate the Kuka controller and the batteries. In the next future the purpose is to obtain a smaller footprint by a better positioning of the internal hardware. This platform has to be considered a developing prototype, therefore the possibility of having the space to integrate and test various hardware has been considered more important compared with the minimal dimensions.

An omnidirectional platform has three degrees of freedom on the plan, therefore the three generalized independent speeds have to be controlled. These speeds can be coupled one by one to an omnidirectional wheel so the minimum number of non conventional wheels to achieve omnidirectional maneuverability is three. Employing more than three unconventional wheels has the advantage of providing more points of contact with the floor, and improving thus the stability of

the platform, but it complicates the design because you need a suspension system or an articulated chassis to allow that all wheels touch the ground simultaneously.

The arrangement of the wheels is another important parameter. In this case, based upon the previous experience of the mechanical department, [16] it has been decided to place them equally spaced by angles of 120 degrees.

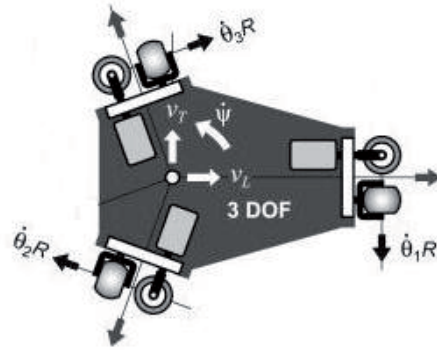

Figure 5.4: Previous developed platform

The previous considerations have led to the development of this prototype (fig. 5.5).

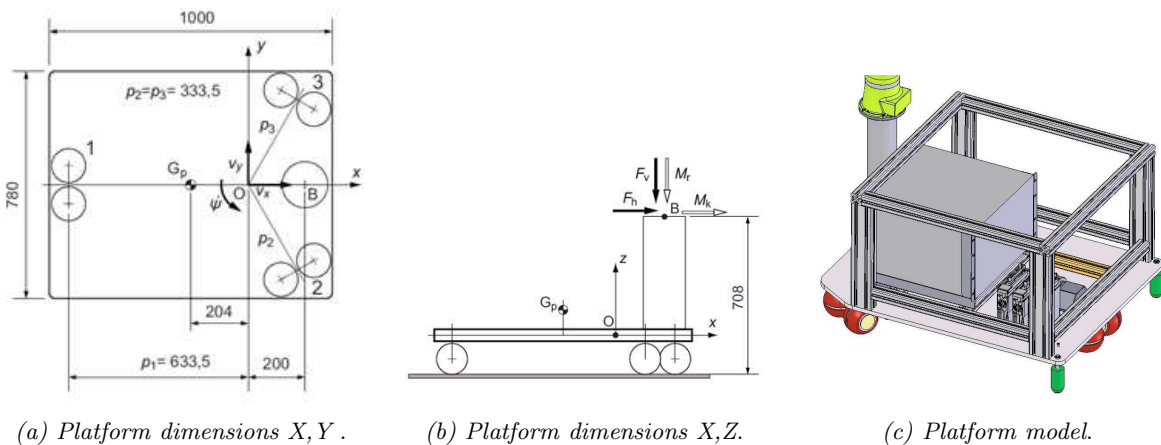

Figure 5.5: Actual omnidirectional platform prototype.

5.4 Joystick

To obtain real-time trajectory control during the runtime, we have decided to use a joystick in order to have the possibility to control the three generalized speeds, of which the platform is capable, at the same time.

To test the platform we have decided to use a normal joystick for PC gaming. The used model

is a Thrustmaster T-Flight Stick X (fig. 5.6).



(a) Thrustmaster T-Flight Stick X.

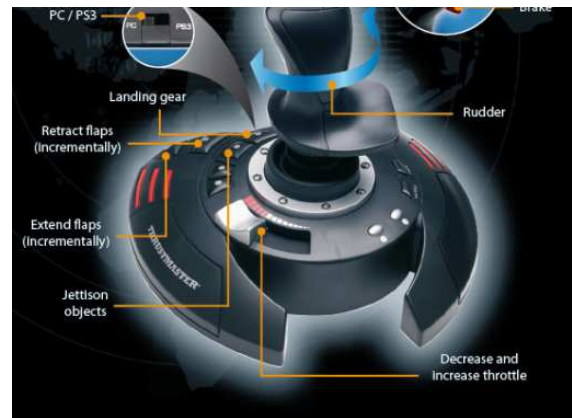

(b) Controllable speeds.

Figure 5.6: Used joystick.

Chapter 6

Involved Software

In this part we are going to describe the software that has been used during the project focusing on the implied characteristics.

6.1 SOEM

6.1.1 What is SOEM?

SOEM is an EtherCAT master library written in C. Its primary target system is GNU/Linux, but SOEM tries not to impose any design architecture therefore it can be used in generic user mode, PREEMPT_RT or Xenomai. It provides the user application with the means to send and receive EtherCAT frames.

SOEM is a free software that can redistributed and/or modified under the terms of the GNU General Public License version 2 as published by the Free Software Foundation.[20]

It is up to the user application to provide means for:

- Reading and writing process data to be sent/received by SOEM (fig. 6.1)
- Keeping local IO data synchronised with the global IOMap
- Detecting errors reported by SOEM
- Managing errors reported by SOEM

It is developed by Arthur Ketels and the version 1.2.8 has been recently released¹. To see all

¹On July 2012

the features SOEM provides, have a look at its site². To understand better the used terminology as well as the SOEM code, an EtherCAT introduction is provided in the Appendix A.

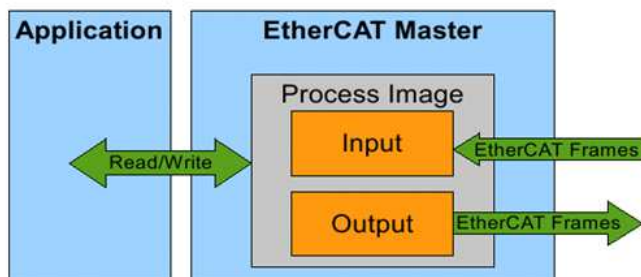

Figure 6.1: Relationship between Application and EtherCAT master:

The synchronization of the data-flow between the Process Image and the Application is done, in our program using Orocos 6.2.

It is important to underline that, to ensure real-time performances using SOEM, it has to be used with RTNet. To set up it, it can be useful to have a look at the links [15] and [27] that discuss the subject in the Orocos mailing list.

6.1.2 Main SOEM commands

In the developed code some SOEM functions are used. Here they are briefly described.

- *ec_init(ifname)* initialise SOEM, bind socket to *ifname*.
After the start of the application we need to set up the NIC to be used as EtherCAT Ethernet interface. In a simple set-up we call *ec_init(ifname)* and if SOEM comes with support for cable redundancy we call *ec_init_redundant* that will open a second port as backup. You can send NULL as *ifname*, if you have a dedicated NIC selected in the *nidrv.c*. It returns a number greater than 0 if it succeeds.
- *ec_config_init(usemap)* enumerate and initialize all slaves. It requests a BRD (Broadcast Read) of address 0, all fully functional slaves in the network will respond to this request, and therefore we will get a working counter(*wkc*) equal to the number of slaves in the network. *ec_config_init* also sets up the mailboxes for slaves that support it. When *ec_config_init* finishes it will have requested all slaves to state PRE_OP. All data read and configured are stored in a global array *ec_slave[slave_number]* that acts as a placeholder for key values.

²<http://soem.berlios.de>

If the *usemap*³ option is activated, this function fills the array, if possible, using the correspondent slave's information stored in *ec_configlist[]*, being faster than reading the slave by EtherCAT through SII. The check is performed comparing the slave's manufacturer and identification number read from EPROM (see appendix A.2 for the EPROM description) to the same fields saved in the list for every slave in the list.

- *ec_config_map(&IOmap)* configure the IOmapping by saving the correct fields of the structure *ec_slave*.
It will create an IOmap and configure the SyncManager's (see A.2) and FMMU's (see A.2) to link the EtherCAT master and the slaves. The IO mapping is done automatically.
During mapping, SOEM also calculates an expected WKC for the IO mapped together. When the mapping is done SOEM requests slaves to enter *Safe Operational*.
- *ec_config(usemap, &IOmap)* is the configuration function that generally the user has to call. It internally calls *ec_config_init(usemap)* and then, if possible, *ec_config_map(&IOmap)*.
- *ec_slave[slave_number].state = DESIRED_STATE* changes the field state of the *slave_number* in the *ec_slave* structure. The change is imposed after the *ec_writestate* command. If the *slave_number* is 0 then all the slaves are involved.
- *ec_writestate(slave_number)* write slave state, if *slave_number* = 0 then write to all slaves. The function does not check if the actual state is changed.
- *ec_readstate* reads all slave states in *ec_slave* and return lowest state found.
- *ec_statecheck(slave_number, DESIRED_STATE, EC_TIMEOUTSTATE)* checks if the *slave_number* has the state *DESIRED_STATE* waiting *EC_TIMEOUTSTATE*. It returns the requested state, or found state after time-out. This is a blocking function.
- *ec_configdc()* sets DC's of all slaves to sync with the first, measure propagation delays.
- *ec_dcsync0 (slave_number, active, CycleTime, CycleShift)* if *active* sets DC of *slave_number* to fire a sync0 event at *CycleTime* interval with *CycleShift* offset, both expressed in nanoseconds. The slave gets triggered at the next whole multiple of the cycle time plus the cycle shift + 100ms and then at every cycle time.

Shift can be used for two purposes:

1. offsetting the trigger moment of slave Y in relation to slave X.
2. offsetting the trigger in multiple cycles. For example if your cycle time is 1ms and the shift is 1000ms then the first sync pulse is delayed another 1sec. This option can be used to prevent time-outs of the slaves PDO to sync check too. [21]

³*usemap* is a boolean and therefore can be true or false.

- *ec_send_processdata* transmits process data (PDO) to slaves.
Uses LRW, or LRD/LWR if LRW is not allowed (blockLRW). Both the input and output process data are transmitted. The outputs with the actual data, the inputs have a placeholder. The inputs are gathered with the *ec_receive_processdata* function. In contrast to the base LRW function, this function is non-blocking. If the process data does not fit one datagram, multiple are used. In order to recombine the slave response, a stack is used. It returns a number greater than 0 if process data is transmitted
- *ec_receive_processdata* receives process data (PDO) from slaves.
Received datagrams are recombined with the process data with help from the stack. If a datagram contains input process data it copies it to the processdata structure. *timeout* is expressed in microseconds. It returns the workcounter.
- *ec_SDOread(slave_number,index,subindex,CA,psize,p,timeout)* It is the function that executes the CoE SDO read and it is blocking. It can be used to access the Dictionary Object in two ways: Single subindex or Complete Access.
Only a “normal” upload request is issued. If the requested parameter is ≤ 4 bytes then a “expedited” response is returned, otherwise a “normal” response. If a “normal” response is larger than the mailbox size then the response is segmented. The function will combine all segments and copy them to the parameter buffer. It returns the workcounter from last slave response.

Arguments: *slave_number*= Slave number;*index* = Index to read;*subindex*= Subindex to read, must be 0 or 1 if CA is used;*CA* = FALSE = single subindex. TRUE = Complete Access, all subindexes read; *psize* = Size in bytes of parameter buffer, returns bytes read from SDO; *p* = Pointer to parameter buffer; *timeout* = Timeout in μs , standard is EC_TIMEOUTTRXM.
- *ec_SDOwrite(slave_number,index,subindex,CA,psize,p,timeout)* It is the function that executes the CoE SDO write, blocking. It can be used to access the Dictionary Object in two ways: Single subindex or Complete Access.
A “normal” download request is issued, unless we have a really small mailbox and small data, then an expedited transfer is used. If the parameter is larger than the mailbox size, then the download is segmented. The function will split the parameter data in segments and send them to the slave one by one.

Arguments: *slave_number*= Slave number;*index* = Index to read;*subindex*= Subindex to read, must be 0 or 1 if CA is used;*CA* = FALSE = single subindex. TRUE = Complete Access, all subindexes read; *psize* = Size in bytes of parameter buffer, it returns bytes read from SDO; *p* = Pointer to parameter buffer; *timeout* = Timeout in μs , standard is ec_TIMEOUTTRXM.
- *ec_close()* terminate EtherCAT communication and close socket.

SII.

For our slaves, with the current PDO mapping, this line has to be added in the list:

```
{/*Man=*/0x00000539,/*ID=*/0x02200001,/*Name=*/' 'SGDV' ',/*dtype=*/7,
/*Ibits=*/104,/*Obits=*/104,/*SM2a*/0x1100,/*SM2f*/0x00010074,
/*SM3a*/0x1358,/*SM3f*/0x00010030,/*FM0ac*/1,/*FM1ac*/1}
```

The required data can be retrieved running *slaveinfo.c* from the SOEM tests or with our Orocos Master's correspondent function.

6.1.4 SOEM standard command sequence

To have our program working, SOEM commands have to be done respecting a standard sequence that takes care of:

- initializing EtherCAT
- switching devices state (see ESM in the appendix A.2)
- performing PDOmapping (if desired) (see A.3) or modifying other parameters using SDO (see A.3) commands
- configuring and activating DC clock mechanism (see A.2)
- performing fast data exchange during the process using PDO (see A.3)

An example of SOEM standard sequence could be:

```
ec_init(ethNamePointer);
ec_config_init(usemap);
ec_slave[0].state = EC_STATE_PRE_OP;
ec_writestate(0);
ec_statecheck(0, EC_STATE_PRE_OP, EC_TIMEOUTSTATE);

//Setting parameters and configuring PDO mapping using SDO communication
ec_SDOwrite(...)/ec_SDOread()

ec_config_map(&IOmap);

//DC configuration if DC clock is going to be used
ec_configdc();
ec_dcsync0(slaveNumber, state, cycleTime, shift)

ec_slave[0].state = EC_STATE_SAFE_OP;
```

```

ec_writestate(0);
ec_statecheck(0, EC_STATE_SAFE_OP, EC_TIMEOUTSTATE);

ec_slave[0].state = EC_STATE_OPERATIONAL;
ec_writestate(0);
ec_statecheck(0, EC_STATE_OPERATIONAL, EC_TIMEOUTSTATE);

//Starting PDO data transfer
loop { ec_send_processdata; ec_receive_processdata; }

//System is up and slaves are running...

```

6.1.5 SOEM and DC clock

As it can be read in the appendix A.2 DC clock is a mechanism used to synchronise the various devices present in the net. Using SOEM every device can be configured to use DC clock or not. To use the DC clock mechanism there are mainly two possibilities:

- forcing DC time to sync with that of the master
- syncing Master's loop to the DC System Time by reading the `ec_DCTime` variable

The first possibility is presented as the preferred one in EtherCAT documentation but it is very difficult to find an environment for the master (hardware and OS) that has a good system clock, therefore the approach that is suggested in SOEM examples is the second one. Indeed only some embedded systems have a 32KHz clock, some others are not monotonous and since SOEM is OS and hardware agnostic therefore it opts for the second option. However the first possibility can be described “easily” in pseudo code. In this case, the cycle, that is cyclically executed to send and receive PDO data, has to be [21] :

```

{
    send PDO data
    receive PDO data
    new slave reference time = master time - EtherCAT offset
    FPRW(reference slave, 0x910, new slave reference time)
    execute control operations
    wait for cycle end
}

```

In this example the repeated write operation to register 0x910 of the reference slave will make it lock to the master time. The EtherCAT offset is the time difference between the master and the reference slave at start (SOEM starts the reference slave with time=0).

Our final choice has been the second option. It has been implemented taking into account the SOEM examples and modified to fit with Orocos TimeService.

This part of the code has the objective to obtain a fixed phase relationship between the frames and the sync0 pulse, remembering that DC mechanism syncs the slaves only amongst each other and not the master. [21]

6.1.6 Problems faced using SOEM with our slaves

Using SOEM library we faced some problems because, even if it is full of features, it is still being developed. However all the faced problems have been solved in the last version 1.2.8 that has been released just few weeks ago, providing not only bug corrections but new functionalities and a useful tutorial too.

LRW bug in SOEM 1.2.5

When the beginning experiments with SOEM started, the current version was 1.2.5 that had a bug involving slaves that do not support the LRW EtherCAT command. The problem was in the function `ec_config_init()` and had been solved in the subsequent versions.

To go on, using 1.2.5 with this kind of slaves the “temporary” solution was to add the line “`ec_group[0].blockLRW = 1;`” before the first call to `ec_send_processdata/ec_receive_processdata` functions in the program linking towards SOEM.

DC issue when using SOEM 1.2.5 with not LRW slaves

From a thread in the SOEM user mailing list resulted that SOEM 1.2.5 could not work using DC clock with slaves that do not support the LRW command. Fortunately we could go on with the development of the code obtaining the SOEM 1.2.6 alpha.

Activating DC mode in our slaves

Usually a slave should just lock to the signal whenever it is available, but, in our case it does not happen because the EtherCAT module SGDV-OCA01A decides what mode to use in the pre-op to safe-op transition.[21]

It reads the sync0 registers from the PDI side to check if the master has programmed DC with sync0 command in the slave. Therefore the command sync0 has to be sent while the slaves are in pre-operational state.

Alarm AA12 when using synchronisation error counter

EtherCAT module SGDV-OCA01A has a sort of counter [that can be deactivated] to verify if it has received valid PDO in last sync0 cycles. The module manual explains that: “The Internal Error Counter is incremented by 3 if the process output data is not updated (a no Receive (SM2) event occurs) at Sync0 event. When the process output data is normally updated, the Internal Error Counter is decremented by 1. The Internal Error Counter is reset when the ESM state is transited to OP from SAFEOP.” [8]

Using our slaves, without this counter, avoids any problem but, if the slave is started with this counter switched on, the error AA12 appears from the beginning, when the slaves are still in the configuration phase.

The problem has been analysed writing to the SOEM mailing list [21] and finally was solved changing the SOEM standard sequence in this way:

```
ec_init(ethNamePointer);
ec_config_init(true);
ec_slave[0].state = EC_STATE_PRE_OP;
ec_writestate(0);
ec_statecheck(0, EC_STATE_PRE_OP, EC_TIMEOUTSTATE);

//Setting parameters and configure PDO mapping using SDO communication
ec_SDOwrite(...)/ec_SDOread()

ec_configdc();
ec_config_map(&IOmap);
ec_dcsync0(slaveNumber, state, cycleTime, shift)

//Starting PDO data transfer
loop { ec_send_processdata; ec_receive_processdata; }

ec_slave[0].state = EC_STATE_SAFE_OP;
ec_writestate(0);
ec_statecheck(0, EC_STATE_SAFE_OP, EC_TIMEOUTSTATE);

ec_slave[0].state = EC_STATE_OPERATIONAL;
ec_writestate(0);
ec_statecheck(0, EC_STATE_OPERATIONAL, EC_TIMEOUTSTATE);
//System is up and slaves are running...
```

Moreover the line `ec_FPWRw(configadr, ECT_REG_ALCTL, htoes(EC_STATE_SAFE_OP), EC_TIMEOUTRET);` of the function `ec_config_map()` in the file `ethercatconfig.c` has to be removed to prevent the automatic switch of the state to *Safe Operational*.

The error was caused because the first sync0 event takes place 100ms after the command while `ec_config_map()` function can take more time, therefore could happen that there were various milliseconds with the sync0 event cycling but with the master still executing the `ec_config_map()` function.

Anyway the code written and explained in these paper uses the usual SOEM sequence to be more reusable with other slaves. Using this code our hardware can be controlled deactivating the counter or setting the CycleShift in the command `ec_dcsync0()` to an appropriate value.

6.2 OrocOS

6.2.1 Introduction

OrocOS is a project that aims at a general-purpose, open source, modular framework for robot and machine control. Today, *The SourceWorks*⁴ is the main contributor to the OrocOS toolchain's real-time infrastructure, while many other organizations build on top of that. The OrocOS Real-Time Toolkit is not an application in itself. It provides the infrastructure and the functionalities to build robotic applications in C++. One of its advantages is the Real-Time Toolkit (RTT) that allows real-time guarantees. This library has been developed to run on top of a (real-time) Linux operating system.

The OrocOS project supports three C++ libraries: the Real-Time Toolkit (RTT), the Kinematics and Dynamics Library (KDL), the Bayesian Filtering Library (fig. 6.3).

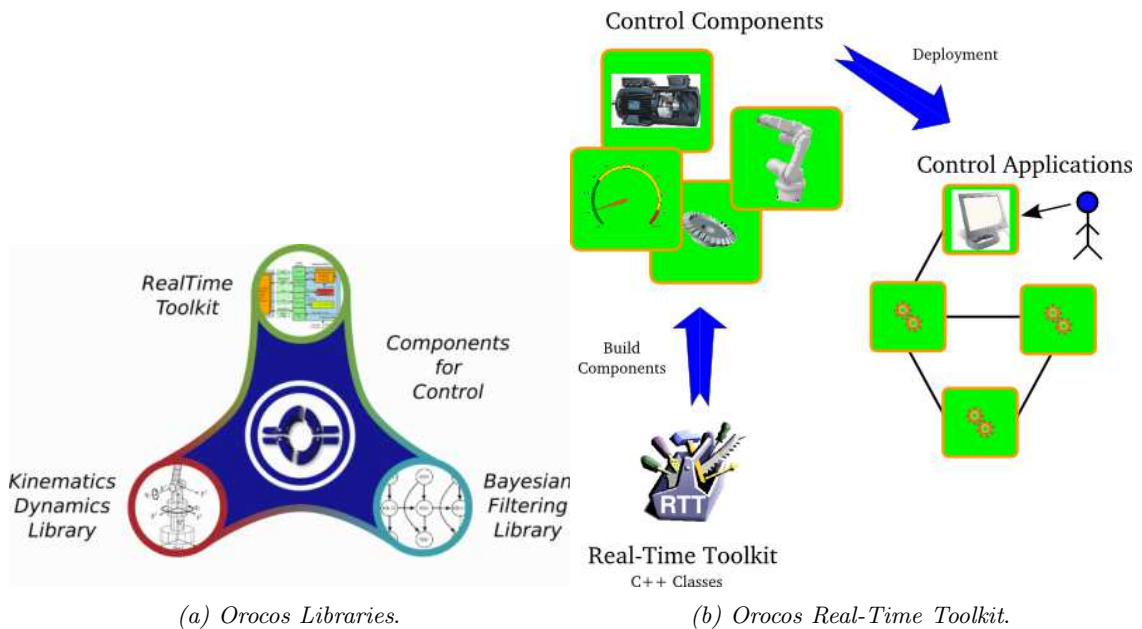

Figure 6.3: OrocOS Libraries and General idea

While RTT has an important role in this project, the other 2 libraries are not used. OrocOS provides another library too, the OrocOS Component library (OCL) that is partially used, mainly for the Reporter Component. The RTT provides, among other things:

- Lock free, thread-safe, inter-thread function calls.
- Communication between hard Real-Time and non Real-Time threads.

⁴<http://www.thesourceworks.com>

- Synchronous and asynchronous communication between threads.
- Application and platform independent implementation.

6.2.2 The TaskContext object

An Orocos application built with the RTT is based on TaskContexts. A TaskContext is an active object which offers thread safe and efficient ports for (lock-free) data exchange. Furthermore a TaskContext can react to events, process commands, or execute Finite State Machines in hard real-time. It can be configured on-line through its interface (set/get values) and through XML files.

In a TaskContext data flow through ports and are manipulated by algorithms in the component. It can be seen as a software component with an own frequency and priority, but it depends on the used operating system if these periods and priorities are executed correctly. Every user can implement its own TaskContext object that is similar to a normal C++ class (For an example of a TaskContext have a look at the Appendix C).

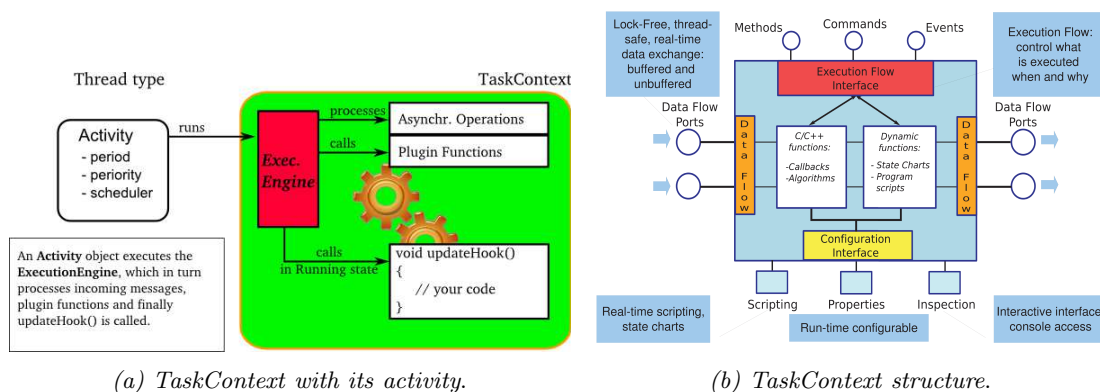

Figure 6.4: TaskContext representation

The “motor” of a TaskContext consists in its Activity that is the thread that executes the operations required by the updateHook function. TaskContext’s Activity can be periodic or non periodic, can have a priority and can be a slave Activity that means it can be executed from the master Activity.⁵

TaskContext object can communicate with other tasks mainly in 2 ways:

- by Ports that are real-time and thread-safe “variables”
- using its interface with its Attributes, Properties and Operations (see section 6.2.2)

⁵We are going to use this kind of activity in our code that can be consulted as a self-explaining example.

The important difference between these two ways is that, while a component can communicate with another by ports simply after that ports have been connected, to use another component's interface, the two components have to be set as peers.

This is just a simplified description of a TaskContext compared with the Orocos Documentation. To have a complete information about TaskContext potentialities have a look at “The Orocos Component Builder's Manual” [28].

To obtain the basic files that have to be modified to personalize your component, the command is:

```
$ orcreate-pkg myTask
```

It makes a folder with the name myTask that contains various files (fig. 6.5).

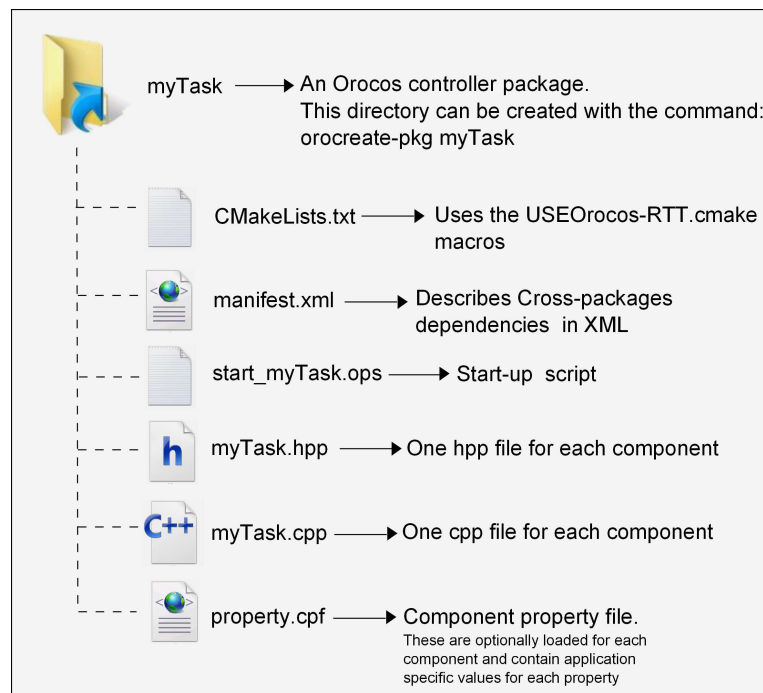

Figure 6.5: Orocos Component Package

To compile and install them the user has to do:

```
$ cd myTask
$ make
$ make install
```

Basic functions

Each TaskContext has several functions, with pre-defined purposes, that the user can implement. These basic functions are used in the different states that a TaskContext can have, and let it to switch from a state to another. The most important function is maybe the updateHook() that will be executed in the running state at a specified frequency. The other functions initiate a state change and they are configureHook(), startHook(), stopHook() and cleanupHook()(fig. 6.6).

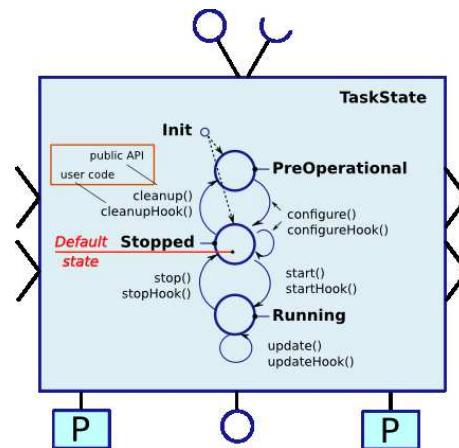

Figure 6.6: TaskContext's states

Examples of tasks that can be implemented in one or more TaskContext are:

- to read/write data from I/O devices via a driver.
- to convert this data in a physical meaningful form for the control algorithm.
- to control algorithm.
- to generate reference signal for control algorithm.
- to take care of the user interface (user controls the application).

If more than a TaskContext is used the synchronization has to be taken into account (see section 6.2.4). Visual examples where more than a TaskContext is used are shown in figure 6.7.

Inside a TaskContext

The interface of a TaskContext is its “calling card”. In this interface a Component presents its ports to communicate data and few proper variables and functions that can be seen and/or modified or called by another component that has to be a peer. The variables that appear in the interface are

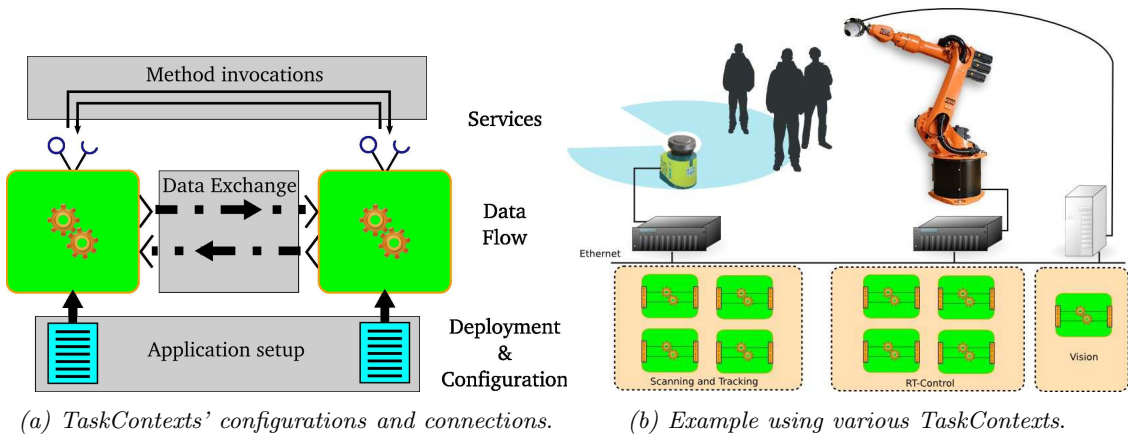

Figure 6.7: TaskContexts' connections and organization

called Attributes or Properties while the functions are named Operations. These Operations can be called by another component and executed by the proprietary's thread or by the calling thread.

The possibility of seeing each other interface depends from the peer relationship between components.

Attributes and Properties

A TaskContext may have any number of attributes or properties, of any type. They can be used by programs in the TaskContext to get (and set) configuration data. The task allows to store any C++ value type and also knows how to handle Property objects. Attributes are plain variables, that can be changed during the run-time, while properties, that is advised to keep constant⁶ during the run-time, can be written to and updated from an XML file.[28] These last ones are intended to be used mainly for configuration purposes because their changes are real-time but not thread-safe.

Services

Various functions can be implemented in services and then added to a TaskContext. Basically Services are components without the execution engine or, in other words: service=component-“thread”-“hooks” so they can be considered “light components”.

⁶They can be changed during the run-time but it is not recommended.

6.2.3 TaskContext deployment

When the desired task, for example, *myTask* has been compiled and installed the user can start to use it interacting with the Deployer component. This application consists of the DeploymentComponent which is responsible for creating applications out of component libraries and the TaskBrowser which is a powerful console tool which helps you to explore, execute and debug components in running programs [28]. The TaskBrowser is itself a component, developed for user interaction with other components and it can be connected only to one component at a time showing its interface.

Generally a user can deploy [=launch the programmed TaskContexts] directly using the Deployer. In this case the standard command sequence would be:

```
$ deployer-gnulinux //Writing in the console you switch to Deployer application
import ( 'myTask' )
loadComponent ( 'DesiredName' , 'myTask' )
```

However in case of using more than a Component, or in case you desire to set easily some parameters each time, you would be interested in doing that in an “automated” way without writing each time the same commands in the Deployer. To do that there are two different solutions that have a little difference in syntax. They are dynamic deployment and static deployment.

In the static deployment components are fixed at compilation time using the oromain syntax that lets you write a C++ program obtaining its executable file, that automatically loads the Deployer and all the desired TaskContexts.

In the dynamic deployment the user has to edit a text file, for example “myConfiguration” that can have the extension .ops or .xml and use the command:

```
$ deployer-gnulinux -s myConfiguration.ops
```

There is an important difference between using a configuration file with the extension .ops and with the extension .xml. It is the different syntax that the user has to respect. In this project mainly .ops configuration files are used so we are going to make examples only with this kind of syntax.

The reporter component

Before seeing the first “complete” minimal example of a configuration.ops it is compulsory to introduce another important component of Orocos, the OCL::ReportingComponent for monitoring and capturing data exchanged between Orocos components.

Each Orocos component can have a number of data ports. The user can configure the reporting components so that one or more ports, of one or more peer components, are captured. The reporting components can work sample rate based or event based. A number of file format can be selected.

In conclusion this component can capture data from various components, if these data are ports, properties or attributes and log them in a text file with various formats. It can be used in conjunction with the program Kst [19] to obtain graphs of these data during the run-time.

Typical .ops configuration file

In this example we are going to load two components, connect their ports and set them as peers.

```
import (" master" );
import (" slave" );

//Load the components we are going to use
loadComponent (" Master" , " master" );
loadComponent (" Slave" , " slave" );

setActivity (" Master" ,0,10,ORO_SCHED_RT);

connectPeers ( " Master" , " Slave" );

//Here we use the master's activity to run the slave
setMasterSlaveActivity (" Master" , " Slave" );

var ConnPolicy cp_1
cp_1.type = DATA
cp_1.size = 1
cp_1.lock_policy = LOCKED

connect (" Platform.port" , " Master.port" , cp_1)

Master.configure ();
Master.start ();
```

6.2.4 How to synchronize a task

First of all it's necessary to explain that ports can be configured to keep the last data from another TaskContext and that it's also possible to save old data in a buffer. Therefore data-exchange is synchronized without the necessity that all the components are executed synchronously. In other words Orocos lets the user design a system where all the components do their things whenever they can, using the "latest" available data ensuring an optimally performing solution. [29]

However, sometimes, mainly for control purposes it's possible that two tasks have to be synchronized. With synchronized, we mean that the controller task, for example, starts its execution just when it obtains new data from the controlled task and that the controlled task reads data from the controller just when they are ready.

In Orocos there are different ways to obtain synchronization between tasks:

- Using an Eventport between tasks
- Using SlaveActivity
- Using the TimeService

All these three different approaches have their merits but if the system is rather "centralized" the whole thing (read hardware, compute control action, output to hardware again) could be done in one single component. Moreover if all the computational functions are designed in a decoupled way, it won't be a problem to put them in separate components later on, when really necessary. In other words these solutions have to be taken only if strictly required, since they can lead to an undesired behaviour.

An *EventPort* is an *InputPort* which wakes our task up when data arrives.[28] When the Eventport solution is adopted with an aperiodic activity, the priorities have to be set right such that the scheduler knows it has to schedule the controller after the controlled thread. This is somewhat fragile since any process/thread in our system with higher priority than the controller, but lower than the hardware, running on the same core, will disturb this balance. [29]

Using *SlaveActivity* guarantees at least that the controller is as performant as the controlled task, but indeed it is fragile as well since the controller only gets as much time as the controlled task and doesn't scale over multiple cores. [29]

Finally consulting the mailing list we have been lead to the conclusion of using eventports fore some components and SlaveActivity for others, even if the more suitable solution would probably be an RTT patch making the EDF scheduler of Linux available to components. This would allow the controller to set a deadline equal to the next start period of the controlled component. [29]

Chapter 7

Orocos EtherCAT communication components

In this part we are going to explain the software implementation of the Orocos components that provide the communication through EtherCAT.

7.1 Orocos EtherCAT master

7.1.1 Developing a SOEM/Orocos master

As described, SOEM has a simple portability and doesn't provide any limitation on the applied design but it requires a program that manages the calls to the functions that it gives in the correct order, taking care of the data coherence when using high frequency PDO data transmission. To obtain this objective, the Orocos community has already written an Orocos component that, linking towards SOEM, takes care of the EtherCAT communication managing inputs and outputs data that are regularly presented to the ports of this component. It is a really well done transparent master that uses a unique TaskContext for the master and automatically extends its functionalities to manage the connected EtherCAT slaves using plugins and RTT::services.

Anyway it presents some implementative characteristics that limit its usefulness in our project:

- Orocos doesn't provide, yet, the possibility of using the marshalling plugin so that it can marshal the properties of another service and as in this architecture (SOEM/Orocos Master) every slave is a service, it would be impossible to use this powerful middleware to load automatically properties from an xml for every slave in the Network. To obtain that, the marshalling plugin has to be extended but it is a work outside our target.

- The table that SOEM/Orocos Master uses to create a service for every slave is based on names from the field `ec_slave[i].name` of SOEM library. If this field is not well filled, in slave's EPROM, the correspondent driver service will not be created. In our case SOEM can't find the name of the driver and as described in `ethercatconfig.c` the function `ec_siifind()` makes a constructed name that can't be used as the name of a class. Therefore the absence of a standard name, memorized in the EPROM correspondent field, makes our drivers not working at all with SOEM/Orocos Master.
- We are going to use EtherCAT slaves that are servo-motors. We can be interested in having different settings for every motor, depending on the different load caused by the platform. With SOEM/Orocos Master we would miss a mechanism to have very specific driver implementations for a specific slave and specific properties for that slave. This is caused by the fact that all the slaves with the same product name are coupled with an identical service load from the table.
- As we are going to use multiple axis control, the use of the internal EtherCAT synchronization mechanism of DC clock is recommended and it isn't implemented with the actual Orocos/-Master yet, even if it would be a little effort to modify the code to work with this mechanism too.

For these reasons we have decided to write a different Orocos EtherCAT Master that meets the needs of our application.

Basic ideas

Our Master has been developed with four basic ideas in mind:

1. Being transparent, that means that the Master component deals only with the task to transmit data over EtherCAT. Data for every slave are managed, inside the computer, by another Orocos component, specific for every slave, that we can call "virtual slave". There is a "virtual slave" for every "real slave".
2. Easy to be used with new slaves, that means that the user has only to write a small Orocos component specific for his slave in order to make the EtherCAT communication works.
3. Highly configurable because the user can configure, from the beginning, each specific slave with a specific configuration that will be applied exactly to this slave. Moreover there is the possibility of setting slave's parameters simply using an xml document for every slave.
4. Ready to be used with the DC clock synchronization mechanism.

About the implementation

As detailed, our EtherCAT Master has been developed using the Orocos middleware to ensure real-time performances and to provide an easy data-flow managing, while the EtherCAT communication has been handled using the SOEM library.

An Orocos TaskContext for every slave

As explained, we have decided to have a “virtual slave” for every slave that is connected through EtherCAT. We can imagine that for each “real slave” there is a sort of “virtual slave” that takes care of the slave’s data that are sent through EtherCAT and that are saved in the Master IOmap (see section 6.1.3).

In our case, this “virtual slave” is simply an Orocos TaskContext with specific code that depends from the slave hardware and from its desired use. This principle can be considered a nonsense because the “virtual slave” can’t communicate directly with its real pair without passing through the Master¹ but this solution has been chosen to allow Master transparency and to have the possibility of loading properties using the Orocos Marshalling service. Moreover the possibility of using *slave activities* (see section 6.2.4) fits perfectly this case.

The feature of loading properties using the Orocos Marshalling service has been considered really useful in order to give the user a simple way to change all the slave’s parameters editing simply an xml with the data that he reads in the slave’s manual.

Virtual slave matching

With the previous idea in mind the problem was how to perform the matching between the “virtual slave” and the “real slave”. There are various possible solutions.

The existent SOEM/Orocos EtherCAT Master uses a table and automatically matches the slaves with their correspondent service basing its choice upon the slave product name. This is an automated solution that results really simple for the user that has to do nothing. Anyway it represents a small lack of configurability because the user can’t control two slaves that have the same product name in a different way². For this reason it has been decided to let the user set this matching manually in order to allow a higher configurability at the cost of a lower automation.

¹An update of the “virtual slave’s” variables affects the “real slave” only after the Master update.

²For example if the user desires to control a motor by torque and another motor by speed and these two motors have the same product name it would be a problem. The problem is caused because first of all they need a different PDOmapping and probably the torque and speed variables haven’t the same dimensions and/or require different calculations and these needs can be satisfied only by two different “virtual slaves”.

With our Master the user that knows the slaves' position along EtherCAT³ and that has created an Orocos component for his slave has to set every "virtual slave" as a peer of the Master in the correct order. It's this order that affects the "real-virtual" slave matching. In this way the first "real slave" will be matched with the first Master's peer and so on.

Master-Slave data exchange

Next problem we had to face was how to exchange data between the Master component and the "virtual slaves" components. Usually components data exchange in Orocos is performed by ports in order to be thread-safe, however using *SlaveActivity* we use an unique thread for the Master and the "virtual slaves". For this reason any data exchange between them is automatically thread-safe. Taking into account the above considerations we have two possibilities to exchange data:

- we can use ports
- we can copy the data in the correct address in the Master IOmap directly from the "virtual slave"

Both solutions present advantages and disadvantages.

Using Ports

In the first implementation the use of ports will ensure data to be thread-safe even when not using *SlaveActivity* but presents the problem that the Master, at the beginning, doesn't know how many slaves will be connected and above all doesn't know which data they are going to send⁴. This information is known only after the PDOmapping and after that the command *ec_config(usemap, &IOmap)* has been executed by the Master.

It is important to underline that as the Master doesn't know how many slaves will be connected, it doesn't know how many ports it has to create. But in Orocos you have to declare the ports you are going to use in the Component when writing the code. To solve the problems we have declared the ports as "*RTT :: OutputPort < PDOstream > *output; RTT :: InputPort < PDOstream > *input;*" where *output* and *input* are vectors of ports and *PDOstream* is a vector of unsigned char. This data type has been added to Orocos using the functions *serialize()* and *PDOstreamTypeInfo()*⁵. Using these vectors the problems of port number and port dimension have been solved.

³The user can check the slaves position setting the option *Master.onlySlaveInfo* to true in the .ops. (see the .ops example in section 7.2)

⁴This depends from the PDOmapping.

⁵To understand in which way this kind has been added to Orocos, have a look at the file *PDOstream.h* inside the folder *soem_master*.

These vectors are sized after the command `ec_config(usemap, &IOmap)` when the variables `ec_slavecount` and `ec_slave[i].Ibytes/Obytes` are updated. These ports are automatically created and connected.

Copying data directly

The implementation of the second solution, where data are directly copied in the correct address, is more simple. Besides it avoids waste of time that ports cause, but it can represent a problem when the user who doesn't use DC clock uses "virtual slaves" with a proper activity. Indeed this implementation has to be used in conjunction with `SlaveActivities` to ensure that the data copying is thread-safe.

With this solution, the Master simply passes the "virtual slave" the information it needs. This information contains the directions of the slave's data⁶ and their size. This information is passed after that the command `ec_config(usemap, &IOmap)` has been executed by the Master.

Both solutions ensure that every "virtual slave" manages input and output data from the real slave, establishing an *univocal relationship* and both of them have been implemented⁷. A scheme that can be useful to understand our application can be seen in figure 7.1.

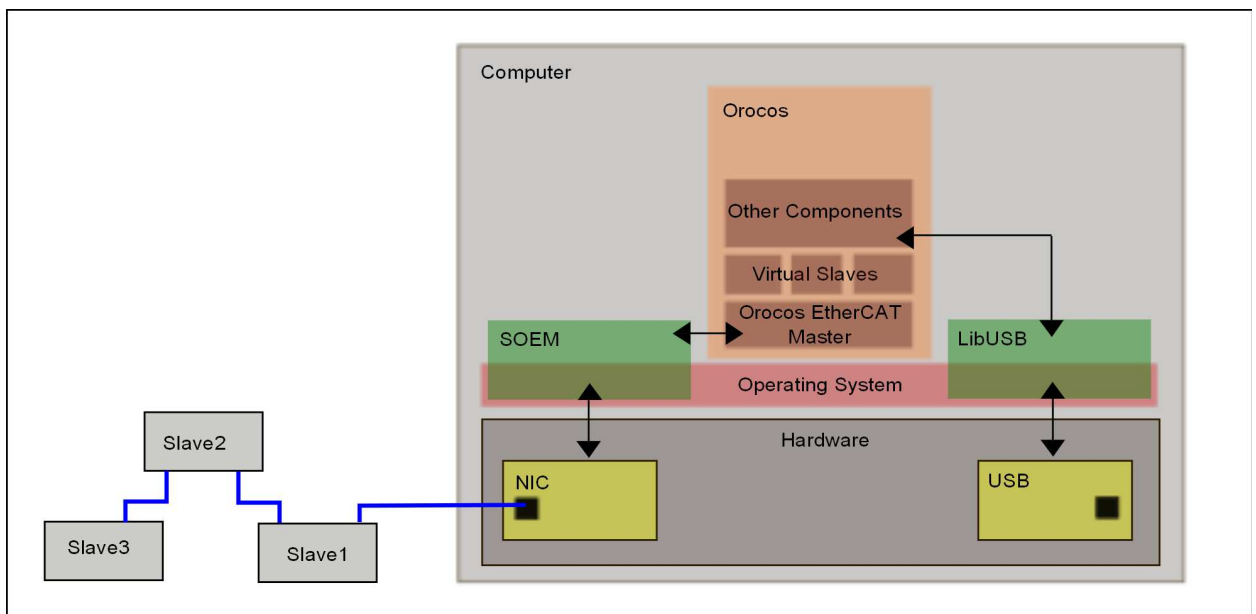

Figure 7.1: Application Scheme

⁶These data are contained in the IOmap and have two different fields: one for the data to read from EtherCAT and the other one for the data to send.

⁷They are presented in different folders in the CD

Master command sequences

To use SOEM, we have written the Master component so that it calls the SOEM functions in the right order. Here we present the sequences that are executed by the Master implemented with ports during its `configurehook()` and its `updatehook()`. The sequences executed by the Master implemented in the other way are very similar.

The command sequence executed during the configuration hook would be:

1. initialize EtherCAT configuration: `ec_init()`
2. initialize default configuration: `ec_config_init()`
3. switch slaves' state to pre-operational: `ec_slave[0].state = EC_STATE_PRE_OP`
4. check if there are the same number of real and "virtual slaves":
`if (sched_list.size() != ec_slavecount)`
5. call sequentially the configuration hook of every slave: `sched_list[i]->configure()`
6. configure SOEM IOmap to contain the correct PDO data of all slaves:
`ec_config_map(&em_IOmap);`
7. switch slaves' state to safe-operational: `ec_slave[0].state = EC_STATE_SAFE_OP`
8. switch slaves' state to operational: `ec_slave[0].state = EC_STATE_OPERATIONAL`
9. resize each port depending on the PDO mapping performed for every slave.

While the commands cyclically repeated in the update hook are:

1. inform the component connected to the eventPort sync that the Master is beginning the updatehook ⁸.
2. receive slave data from EtherCAT `ec_receive_processdata(EC_TIMEOUTRET)`
3. send updated data to the correct virtual slave using ports
4. call the updatehook of every virtual slave `sched_list[i]->update()`
5. read command data from the "virtual slaves" using ports
6. send data to slaves through EtherCAT `ec_send_processdata()`

⁸This port would be used to synchronise the Master Component with the Platform component in our case.

Master's functionalities

The designed Master provides other functionalities such as:

- **DC clock mechanism:** if this option is activated, setting a period of 0 seconds in the Master activity, the Master auto-triggers itself every sync0 period taking care of the drift of its clock, reading the `ec_DCtime` variable⁹.
- **information of every slave** printed in a text file. The basic information about the slave as producer ID, product ID, name and position along EtherCAT, but also a more complete information, such as the PDO mapping and the complete Object dictionary, could be printed in the file.

This function could be especially useful when the Master is used for the first time with new slaves in order to check if the slave's position is the position that the user supposed. It is of great importance since the position of the real slave should be the same as the order of setting "virtual slaves" as Master's peers. When this function is activated the master only reads the information from the slave and doesn't perform the configuration. It simply reads the actual slaves' configuration and stops its execution.

- the possibility of **sending SDO requests** during the run-time.

7.2 Orocos EtherCAT slaves

As explained, the user that wants to use our Master has simply to write a piece of code that is slave dependent. This code, that is specific for the used slave, has to be written in the form of an Orocos component and has to inherit from `soem_slave` and not from `RTT::TaskContext` in order to have some functionalities already implemented. Each slave component can be loaded and become a "virtual slave". Each one of these components can differ from the others because it is written to be used with a different "real slave"¹⁰ or because it uses a different PDO mapping and consequently different control variables.

Generally a slave can directly execute calculations with the data that it receives from the Master. In our case we use the "virtual slaves" only to configure the hardware and to order the received variables in a way that fits better our deeds. Moreover component `SGDV_slave` can be considered as an example where the DC clock mechanism is used.

⁹See the section 6.1.5 to have more information about the use of DC clock with SOEM.

¹⁰A slave that has a different hardware and different functionalities.

About the configuration

The configuration in an EtherCAT slave has mainly two purposes:

1. choosing which data would be updated, usually with high frequency (PDO). This procedure is called PDOmapping (see appendix A.3) and it is done with a sequence of SDO calls.
2. setting parameters such as maximum speed, ecc... Each parameter's value is sent to the slave using an SDO call.

In our case, during the configuration we have to take care of the Orocos communication too, therefore the ports¹¹, to exchange data between the Master and the slave, are created and connected. It is important to underline that we have decided to hard code the PDOmapping because it changes the data that are updated using PDO. In this way we prevent severe problems caused by any unwanted modification.

Other slave's parameters are read from an xml file during the configuration procedure and automatically sent to the "real slave" by SDO calls. In this way the user can change in a very simple manner parameters such as maximum speed, maximum torque, ecc... only by reading the information about the desired parameters in the slave's manual and editing the xml file consequently. This file has for every slave the name *configuringXMLSlaveName_position?.xml* where *SlaveName* is the name of the deployed virtual slave, while *?* is its position in the EtherCAT bus used by SOEM.

During the updatehook

During the update hook the slave reads the data from its real pair and then performs the calculation or sends/receives the data to/from another component. At the end of the loop new data are written to its ports¹² ready to be read from the Master.

Generally it is in the updatehook that calculations, that we want to execute with the received data, can be implemented. In our case in the updatehook we don't execute any calculation but there is a part that is executed only the first times and that takes care of the correct steps that the slave has to do before becoming operative and, in our case, gives power to the motors.

¹¹These ports are used only by the first implemented Master while the other one communicates the slaves the addresses where they have to read and write.

¹²These ports are used only by the first implemented Master while the other one copies the data in the right address in the Master IOMap.

About synchronisation

In our implementation to achieve synchronisation, every slave is executed with the Master thread. It is obtained using the *SlaveActivity* (see section 6.2.4).

Since Master's and slaves' operations will be executed sequentially, the use of ports between these components could be avoided. Because of these reasons, we have implemented the Master in the two described ways: one with ports and the other one without ports.

If you are interested in having different runtime periods for every slave, or in scaling over multiple cores the Master with ports has to be used.

Master Deployment

We are going to show an example of Master deployment in order to explain how the user has to use the .ops file to let the Master match the “real slaves” with the “virtual slaves” in the correct way.

Moreover in this example it is explained how to set the Master to use DC clock or the free running mode. In the lower part of the example Master properties are set. They can be used to print slaves' information or to change the used NIC port.

EtherCAT_Master_configuration.ops

```
import("user_virtual_slave_1");
import("user_virtual_slave_2");
import("soem_master");
//Where user_virtual_slave_1 an user_virtual_slave_2 are Orocos components
//that the user has written inheriting from soem_slave.

//Load the components we are going to use
loadComponent("Master", "soem_master::SoemMasterComponent");
loadComponent("Slave1", "user_virtual_slave_1");
loadComponent("Slave2", "user_virtual_slave_2");
//The user can load how many "virtual slaves" he wants of different "kinds"

//To use DC clocks the period has to be 0 to let internal functions ensure
//synchronism.If you don't desire to use DCclock set the period in seconds.
setActivity("Master",period,10,ORO_SCHED_RT);

//If in the previous line you decided to use DC clocks you need to let the Master
//know the sync0 period you are going to set in your slaves.
set Master.cycletime=250000; //The period has to be set in ns[0 to not use DC].

//This part is important for "real-virtual" slave matching
connectPeers("Master", "Slave1");
```

```
connectPeers( "Master", "Slave2" );
//In this way the first "real slave" will be matched with the "virtual slave" called
//"Slave1" that is of "kind" user_virtual_slave_1, while the second "real slave"
//will be matched with the "virtual slave" called "Slave2" that is of "kind"
//user_virtual_slave_2.

//Slaves are executed using MasterSlaveActivity
setMasterSlaveActivity( "Master", "Slave1" );
setMasterSlaveActivity( "Master", "Slave2" );

//Master settings
set Master.onlySlaveInfo=false;
//Master.onlySlaveInfo is set for default to true.
//When set to true the master only prints in a .txt file the connected slaves'
  information.
set Master.printSDO=false;
set Master.printPDOmap=false;
set Master.ethPort="eth4";

Master.configure();

Master.start();
```

Chapter 8

Orocos control components

In this part we are going to explain the software implementation of the Orocos components that take care of the Platform's control reading motors' data, calculating new control data and sending them. The Orocos component structure we are going to implement can be understood watching this scheme (fig. 8.1) where in the left part you can see the various software and hardware levels that the the EtherCAT data have to pass.

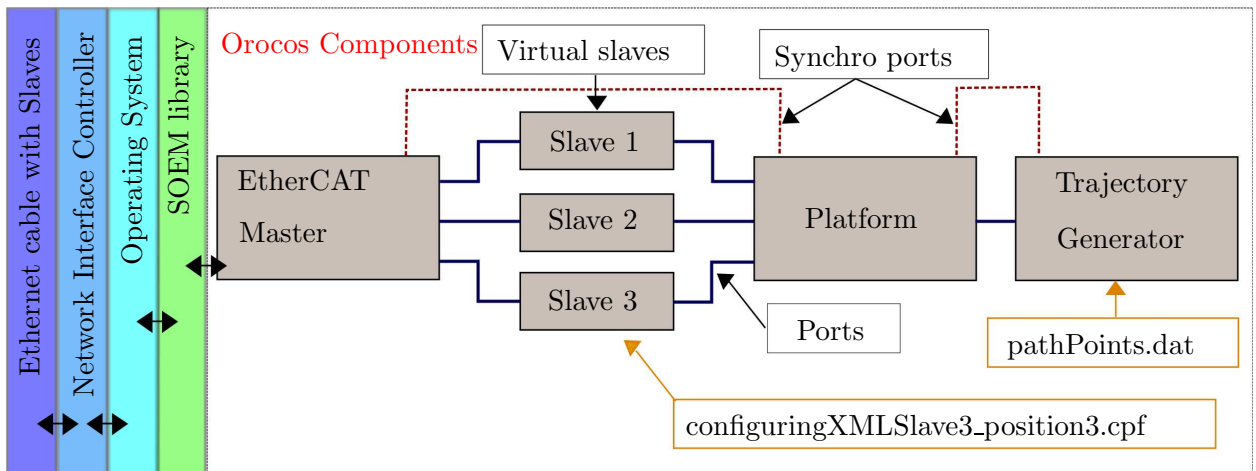

Figure 8.1: Our Orocos components structure: while normal *ports* transport data between components *synchro ports* are Orocos Eventports (see section 6.2.4) that are used for the synchronisation. [Trajectory Generator can be replaced with Joystick when requested]

The orange borders indicate the files that these components can load to set the properties or to know the pathpoints.

For an explanation of which kind of data “are transported by the ports” have a look at figure B.1.

8.1 Joystick component

The Joystick component has been designed to control the platform's movements during the run-time. This component uses the *libusb*[31] library to handle USB communication.

The Joystick has the possibility to use two different reference systems:

1. the mobile reference system that is the platform's reference system
2. the fixed reference system that coincides with the mobile reference system when the platform is started.

It is also possible to reset the fixed reference system to the actual mobile reference system during the run-time in order to give the user the possibility to have a more intuitive platform's response depending on its position. These three possibilities can be selected with three buttons.

About the implementation

The *libusb* commands are mainly used during component's configuration to look for our device and claim its interface.

During the updatehook only the $r= \text{libusb_interrupt_transfer}(\text{dev_handle}, 0x81, \text{data}, 21, \text{E_actual}, 0)$; *libusb* command is used. It reads the joystick axes' and buttons' values returning for each one of them a numeric value from 0 to 255 in an array. In axes case the numbers represent their actual position. It is important to underline that the value 127 is given when the joystick is let in its equilibrium point.

The three axes speeds' values have been rescaled using an offset ¹ and a coefficient, that the user can modify in order to limit the maximum speed that the joystick requires to the platform.

As the required Cartesian axes speeds are proportional to the distance between the joystick actual axes' positions and the equilibrium point², the control is very intuitive and gives a good control sensation. Moreover the user can change the speed not only by changing the joystick axis' position but moving the joystick's wheel too.

To stop the platform and release joystick's USB interface, another button has to be pressed. Anyway to ensure safety, if the *libusb_interrupt_transfer()* returns an error, the Platform is stopped

¹The offset has been used to convert the scale form 0 to 255 to - 127 to 128 in order to have the possibility to send negative speeds

²When the joystick is left it comes back to the equilibrium point and the platform stops

and Joystick³ control is blocked. In this way if the USB cable is disconnected, the Platform stops.

From an Orocos point of view the component uses an aperiodic activity and three ports connected to the platform component. One port is of type *target* and is used to send speeds values, the other two are of type *bool* and are used to choose the reference system and to reset the fixed one.

8.2 Trajectory Generator component

Using an omnidirectional platform, the main advantage is the superior manoeuvrability that it allows. In this case the trajectory tracking does not need the car-like approach that is used with normal platforms, and every differentiable function⁴ that represents a trajectory could be easily tracked.

This Orocos component, that can be executed with a periodic activity or with an aperiodic one if the event port is used to awake it, has two objectives:

1. generate easy geometric trajectories such as a circle, an ellipse and an Archimede's spiral mainly for demo purposes.
2. generate trajectory's references from a certain number of path-points.

Geometric trajectories

After having set the property *Operation_mode* to the chosen trajectory, the user can choose some parameters such as the circle radius, the period or the spiral step editing the .ops text file. Then, when the application is started, the platform will execute the planned trajectory till the user decides to stop it.

Trajectory's references from a certain number of path-points

When this functionality is chosen, the Orocos component has mainly three tasks:

1. reading the path-points from a text file called pathPoints.dat and saving them in a vector

³When we write joystick/platform we mean the real tool while when we write Joystick/Platform we refer to the Orocos component.

⁴You need the differentiability to have the possibility of generating not only the position reference but the speed and the acceleration reference too.

in order to ensure real-time access to them. This operation is performed in the component's configurehook.

The points have to be expressed in this way (*absolute time, position along X axes in meters, position along Y axis in meters, position along θ axis in radians*).

To obtain a square trajectory with a 2 metres side, in 20 seconds the file pathPoints.dat would be:

```
(0,0,0,0)
(5,2,0,0)
(10,2,2,0)
(15,0,2,0)
(20,0,0,0)
```

2. copying in another vector three points for every segment⁵ in order to provide the necessary data to the interpolation algorithm. The three points you need to execute the interpolation are: the initial position of this segment, the final position of this segment, the final position of the next segment.
3. interpolating between the segment beginning point and the segment ending point for the three axes using a third grade polynomial or a fifth grade polynomial with speed 0 at the end of every segment.

Interpolation

The interpolation is done separately for the three axes and the coefficients that characterize the polynomial are calculated at the beginning of every segment being constant till the end of this one.

A fifth grade interpolation algorithm has been developed at the beginning to test Platform's behaviour with very smooth profiles but its development has been interrupted because other laws have been considered more suitable. Therefore it runs with the condition of speed 0 at the end of every segment, while the algorithm that has been mostly tested is the third order polynomial interpolation.

Third order polynomial Interpolation

This algorithm has been implemented after the following considerations.[5] [24]

Given an initial and a final instant t_i , t_f , a (segment of a) trajectory may be specified by assigning initial and final conditions:

⁵With segment, we mean the space Platform runs between two path points

- initial position and velocity q_i, \dot{q}_i ;
- final position and velocity q_f, \dot{q}_f ;

There are four boundary conditions, and therefore a polynomial of degree 3 (at least) must be considered:

$$q(t) = a_0 + a_1(t - t_i) + a_2(t - t_i)^2 + a_3(t - t_i)^3 \quad (8.1)$$

where the four parameters a_0, a_1, a_2, a_3 must be defined so that the desired boundary conditions are satisfied. From the boundary conditions, it follows that:

$$\dot{q}(t_i) = a_0 + a_1 t_i + a_2 t_i^2 + a_3 t_i^3 \quad (8.2)$$

$$\ddot{q}(t_i) = a_1 + 2a_2 t_i + 3a_3 t_i^2 \quad (8.3)$$

$$\dot{q}(t_f) = a_0 + a_1 t_f + a_2 t_f^2 + a_3 t_f^3 \quad (8.4)$$

$$\ddot{q}(t_f) = a_1 + 2a_2 t_f + 3a_3 t_f^2 \quad (8.5)$$

In this manner, it is very simple to plan a trajectory passing through a sequence of intermediate points. If the trajectory is assigned by specifying a sequence of desired points (path-points) without indication on the velocity in these points, the “most suitable” values for the velocities must be automatically computed.

To calculate the intermediate speeds, the path points have to be evaluated three by three:

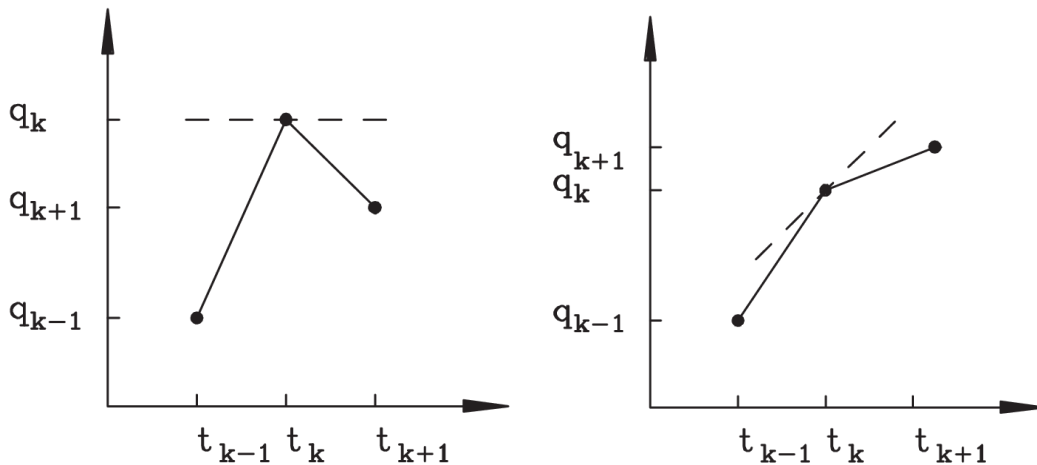

(a) Intermediate speed 0.

(b) Intermediate speed $\neq 0$.

Figure 8.2: Two possibilities that can be found evaluating path-points

$$\dot{q}_1 = 0 \quad (8.6)$$

$$\dot{q}_k = \begin{cases} 0 & \text{if } \text{sign}(v_k) \neq \text{sign}(v_{k+1}) \\ v_k & \text{if } \text{sign}(v_k) = \text{sign}(v_{k+1}) \end{cases} \quad (8.7)$$

$$\dot{q}_n = 0 \quad (8.8)$$

where v_k is the slope of the segment during $[t_{k-1} - t_k]$:

$$v_k = \frac{q_k - q_{k-1}}{t_k - t_{k-1}} \quad (8.9)$$

With these considerations the coefficients are:

$$a_0 = q_i \quad (8.10)$$

$$a_1 = \dot{q}_i \quad (8.11)$$

$$a_2 = \frac{-3(q_i - q_f) - (2\dot{q}_i + \dot{q}_f)(t_f - t_i)}{(t_f - t_i)^2} \quad (8.12)$$

$$a_3 = \frac{2(q_i - q_f) + (\dot{q}_i + \dot{q}_f)(t_f - t_i)}{(t_f - t_i)^3} \quad (8.13)$$

8.3 Platform component

The Platform component is the main component that takes care of controlling the platform's movements. Its main objective is to convert references expressed as speeds in the Cartesian plane to motors' speeds in order to achieve a path of desired positions along the time.

As our servomotors can be controlled by setting a position a speed or a torque, there are various ways to control the platform and to obtain the same movement. Mainly for its simplicity we have decided to start trying our platform with speed reference in order to use simply the Jacobian matrix to calculate the speeds you need.

Going on with the development, a controller that controls by speed, correcting it depending of the positioning error, has been implemented. The software development ended with the implementation of an adaptative controller that uses a platform's model to convert the desired Cartesian speeds into the required torque for every motor taking care of the positioning error.

In order to keep the code more simple, we have decided to use the Eigen matrix library[13]. This matrix library has been preferred among the others because it seems to be faster, suitable for small and medium matrices and, even if it is not real-time safe, it can be used preallocating the space you need in order to ensure real-time performances, as has been discussed in the Orococos mailing list[25].

8.3.1 Open-loop speed control

As explained the first way we had used to control our platform was the most simple one. Using this kind of control we never check platform's position. We simply set a target speed for every motor every cycle time ⁶. This method uses simply the inverted Jacobian matrix (see fig. 8.3). In this

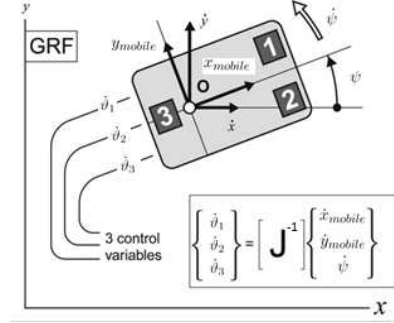

Figure 8.3: Platform position is described by means of Cartesian coordinates x and y , while its orientation is represented by the angle ψ .

case the matrix (eq. 8.14) was already calculated by the Mechanical Engineering Department [9].

$$\begin{bmatrix} \dot{\vartheta}_1 \\ \dot{\vartheta}_2 \\ \dot{\vartheta}_3 \end{bmatrix} = \begin{bmatrix} 0 & 2/D & -2p_1/D \\ -\sqrt{3}/D & -1/D & -2p/D \\ \sqrt{3}/D & -1/D & -2p/D \end{bmatrix} \begin{bmatrix} \dot{x}_{mobile} \\ \dot{y}_{mobile} \\ \dot{\psi} \end{bmatrix} \quad (8.14)$$

Where: D is the wheels' diameters; p is the distance between the wheel and the platform rotation center for motor 2 and 3, while p_1 has the same meaning for motor 1; $\dot{\vartheta}_i$ is the speed of motor i expressed in radians; $\dot{x}_{mobile}, \dot{y}_{mobile}, \dot{\psi}$ are the speeds in the Cartesian plane referred to the mobile reference system.

In order to calculate the motors' speed from the Cartesian speed expressed with respect to the fixed reference system, you need a matrix that takes into account platform rotation with respect to the fixed reference. Therefore the system would be:

$$\begin{bmatrix} \dot{\vartheta}_1 \\ \dot{\vartheta}_2 \\ \dot{\vartheta}_3 \end{bmatrix} = \begin{bmatrix} 0 & 2/D & -2p_1/D \\ -\sqrt{3}/D & -1/D & -2p/D \\ \sqrt{3}/D & -1/D & -2p/D \end{bmatrix} \begin{bmatrix} \cos(\psi) & \sin(\psi) & 0 \\ -\sin(\psi) & \cos(\psi) & 0 \\ 0 & 0 & 1 \end{bmatrix} \begin{bmatrix} \dot{x}_{fix} \\ \dot{y}_{fix} \\ \dot{\psi} \end{bmatrix} \quad (8.15)$$

8.3.2 Actual Position Estimation

As it is clear, a control, that doesn't take care of evaluating if the platform has reached the target position every time, is quite useless. The use of data from moving sensors to estimate change in

⁶The speeds are calculated every updatehook cycle time

position over time is called Odometry. The platform isn't provided yet with an autonomous working system to perform Odometry, therefore we have decided to start to evaluate it simply using the motors' movements.

As explained we are using the motors to move the platform and the motors' encoders to calculate the position. It's evident that this "trick" is affected by slippage due to the wheels but this procedure can be useful to verify the higher holonomy precision that the used spheric wheels promised to ensure. Moreover the idea is to start developing a way to estimate the platform position and to integrate it in the next future using data proceeding from cameras or mouses on board the platform and putting together all the information using the Kalman filter.

The Holonomy problem in mobile robots has been analysed by the Mechanical Engineering Department[1] a few years ago. As explained in the article, an omnidirectional robot can present a non holonomic behaviour. What does it mean? It means that only by reading the motors' movements at the end of the run-time we can't know which the platform's position is.

As explained in the article, there are few constraints that if respected ensure that it doesn't happen. Depending on the respect of these constraints, two different methods have to be used to estimate the position.

Holonomic constraints

As detailed in the previously cited article[1], there are two movements that allow a holonomic behaviour (see fig. 8.4).

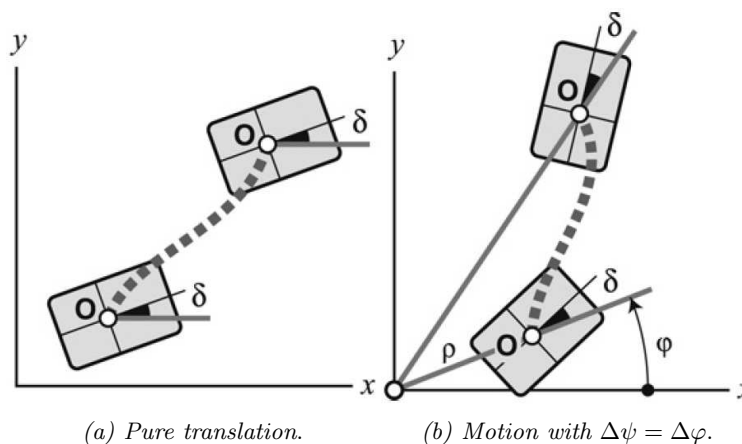

Figure 8.4: Holonomic movements.

a) if the translation and rotation movements are done separately. It means that the platform can't

translate along X and Y and rotate at the same time.

- b) if the platform's rotation speed, with respect to its axes, is exactly equal to the tangent speed of the path. This tangent speed is calculated with respect to the fixed reference system.

Implementation

As explained in the article, if the platform's path requires non holonomic movements we have to perform an integrative odometry, while if holonomic constraints are respected we can perform an algebraic one. It means that if we detect that the constraints are respected we can simply read the motor positions to know platform position and orientation.

As the constraints can be violated in every moment we read the space that every motor has moved every cycle-time in order to calculate platform's movements along the axes X and Y using the formulas:

$$\begin{bmatrix} \Delta\rho_1 \\ \Delta\rho_2 \end{bmatrix} = \begin{bmatrix} \Delta\rho_x \cos \psi - \Delta\rho_y \sin \psi \\ \Delta\rho_x \sin \psi + \Delta\rho_y \cos \psi \end{bmatrix} \quad (8.16)$$

$$\begin{bmatrix} \Delta\rho_x \\ \Delta\rho_y \end{bmatrix} = \frac{R}{\sqrt{3}(p_1 + 2p)} \begin{bmatrix} 0 & -(p_1 + 2p) & (p_1 + 2p) \\ 2\sqrt{3} & -\sqrt{3}p_1 & \sqrt{3}p_1 \end{bmatrix} \begin{bmatrix} \Delta\theta_1 \\ \Delta\theta_2 \\ \Delta\theta_3 \end{bmatrix} \quad (8.17)$$

That are referred to the figure 8.5.

While the angular movement can be calculated independently as regards the holonomic constraints, using the equation 8.18.

$$\psi - \psi_0 = \frac{R}{\sqrt{3}(P_1 + 2P)} \begin{bmatrix} -\sqrt{3} & -\sqrt{3} & -\sqrt{3} \end{bmatrix} \begin{bmatrix} \Delta\theta_1 \\ \Delta\theta_2 \\ \Delta\theta_3 \end{bmatrix} = \frac{-R}{(P_1 + 2P)} (\Delta\theta_1 + \Delta\theta_2 + \Delta\theta_3) \quad (8.18)$$

If the constraints aren't respected we have to use an integrative holonomy. Therefore we have to read motor speeds during the cycle time to obtain the platform speed passing through the Jacobian matrix and then integrate them along the cycle-time in order to get directly platform movements.

As the speed we read from the motors has been verified to be quite noisy, we have decided to use a filtered derivative method [11] in order to manually calculate every motor's speed knowing its movement during the cycle time.

$$\dot{x}_{new} = c_1 \dot{x}_{old} + (1 - c_1) \frac{x - x_{old}}{T} \quad (8.19)$$

Where $c_1 = \exp(-\alpha T)$.

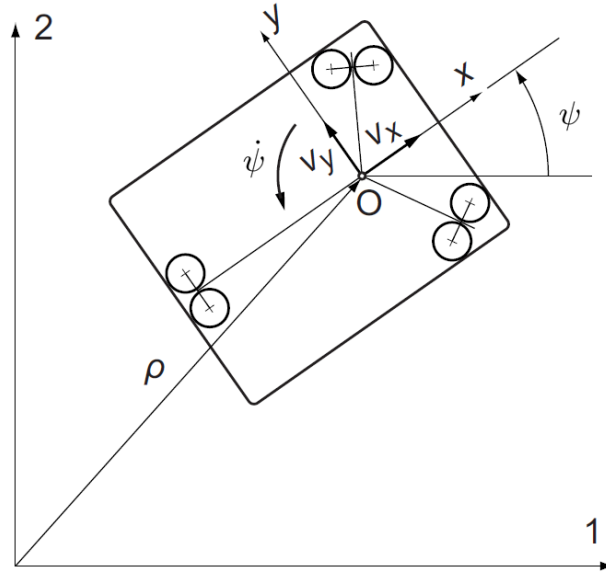

Figure 8.5: Platform position is described by the vector ρ and its projections to the fixed axes 1 and 2, and to de mobile axes x and y .

As it can be noticed reading the code, to check if the constraints are respected or not, we check both the target speeds and the real speeds when verifying the second constraint. This method has been chosen to avoid false positive responses.

8.3.3 Closed-loop speed control

Using the open-loop speed control we achieved quite good results but the positioning error at the end of the trajectory was unchecked and even if it was small (less then a millimetre), when the platform moved quite slow and without outside interference, it was increasing a lot if the platform moved faster or if the user tried to push or pull it.

To avoid this problem and to check if the odometry precision ensured only by the spheric wheels is good, we have decided to implement a simple controller that takes into account the positioning error while tracking a trajectory. Remembering that we are controlling the motors sending a speed reference, we have developed a controller that uses this equation to vary the reference speed depending on the tracking error:

$$\begin{bmatrix} \dot{x}_{required_{k+1}} \\ \dot{y}_{required_{k+1}} \\ \dot{\psi}_{required_{k+1}} \end{bmatrix} = \begin{bmatrix} \dot{x}_{reference_{k+1}} \\ \dot{y}_{reference_{k+1}} \\ \dot{\psi}_{reference_{k+1}} \end{bmatrix} + Kp \begin{bmatrix} x_{reference_k} - x_k \\ y_{reference_k} - y_k \\ \psi_{reference_k} - psi_k \end{bmatrix} \quad (8.20)$$

Where $\dot{x}_{required_{k+1}}$, $\dot{y}_{required_{k+1}}$, $\dot{\psi}_{required_{k+1}}$ are the Cartesian speeds we required to the platform; $\dot{x}_{reference_{k+1}}$, $\dot{y}_{reference_{k+1}}$, $\dot{\psi}_{reference_{k+1}}$ are the Cartesian speeds generated by the Trajectory

Generator Component and $x_{reference_k}$, $y_{reference_k}$, $\psi_{reference_k}$ are the Cartesian positions generated by the Trajectory Generator Component and that represent the desired position in every moment. x_k , y_k , ψ_k are the real actual Cartesian positions calculated from the data that came from motor encoders.

To understand better how it works it can be useful to look at the following scheme (fig. 8.6). Where Z_r is the Cartesian reference positions vector, \dot{Z}_r is the Cartesian reference speeds vector,

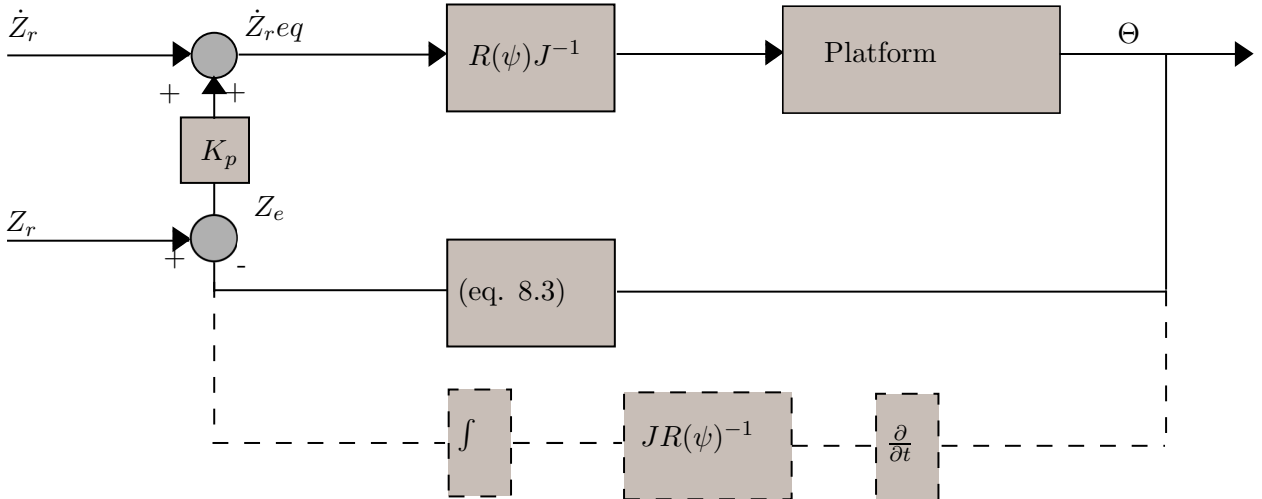

Figure 8.6: Closed-loop speed control design

K_p is the gain for the position error, Θ is the vector of the motors' positions (from encoders) ϑ_1 , ϑ_2 , ϑ_3 and R and J are the rotation and the Jacobian matrices. The dashed part of the scheme is used when equation (8.17) can't be used because of a non holonomic trajectory as explained in the section 8.3.2 Actual Position Estimation. The filtered derivative block is used as explained in (8.19) even if speeds can be directly read to avoid the noise problem, as has been explained before.

This controller has been tried and has demonstrated to work very well. Anyway its stability hasn't been mathematically verified yet, because we are miss data of the speed-control-loop implemented in the Yaskawa drivers.

8.3.4 Control by torque with an adaptive controller

With the objective of controlling directly the torque that the motors produce without using the speed loop that is based on a proper controller we have looked for a method to track a trajectory. Because of the variable payload that can vary the platform mass, and taking care that when the manipulator is mounted its position can change platform moment of inertia, the design of an adaptative controller seems to represent the most suitable solution.

At the beginning an adaptative controller without any model has been designed taking inspi-

ration directly from the article *Adaptive Manipulator Control: A Case Study*[12]. The resulting algorithm worked quite well but sometimes the wheels were slipping because of an excessive torque and this caused position errors ⁷. Moreover this solution could not integrate the information of the position error proceeding from the camera basing its calculus only on motor encoders.

At this point was clear that we needed a platform model in order to have a better working adaptative controller. A very similar problem was described in the article *Adaptive Trajectory Tracking and Stabilization for Omnidirectional Mobile Robot with Dynamic Effect and Uncertainties*[18] therefore we decided to use it adapting the equations to our platform and motors.

The dynamic model with slip

From the equation 8.15 calculating the matrix product letting outside the diameter, expressed as $D = 2R$, and using prosthaphaeresis formulas we obtain:

$$\begin{bmatrix} \dot{\vartheta}_1 \\ \dot{\vartheta}_2 \\ \dot{\vartheta}_3 \end{bmatrix} = \frac{P(\psi)}{R} \begin{bmatrix} \dot{x}_{fix} \\ \dot{y}_{fix} \\ \dot{\psi} \end{bmatrix} \quad (8.21)$$

where $P(\psi)$ that depends only from the platform orientation is:

$$\begin{bmatrix} -\sin(\psi) & \cos(\psi) & p_1 \\ -\sin(\frac{\pi}{3} - \psi) & -\cos(\frac{\pi}{3} - \psi) & p \\ \sin(\frac{\pi}{3} + \psi) & -\cos(\frac{\pi}{3} + \psi) & p \end{bmatrix} \quad (8.22)$$

In order to derive the robot's dynamic model, we assume that the robot has two unknown but constant parameters, the total mass m and the moment of inertia J of the platform. Moreover we have decided to consider the three uncertain but bounded forces exerted on the driving wheels, and neglect the servomotor dynamics.

Analysing the forces that are involved we have F_{fi} , the friction force exerted on wheel i , and F_i , the total force resulting from the servomotor number i . As explained in the article [18] the friction force F_{fi} is divided in two components depending on its directions. F_{Wi} is the component in the wheel rolling direction while F_{Ti} is the friction component in the direction perpendicular to the previous one. This way F_i can be expressed as:

$$F_i = \frac{\tau}{R} - F_{Wi} \quad (8.23)$$

Where τ is the torque we require to the motor, while R is the wheels' radius.

⁷As this solution was implemented but isn't the final one we aren't going to explain the equations here. For all the equations and the coefficients the interested reader could consult directly the code

As explained in the article, with the force equation (8.23) and the friction transversal force F_{Ti} and using the Newton's second law for both translation and rotation we obtain:

$$m \begin{bmatrix} \ddot{x} \\ \ddot{y} \end{bmatrix} = \sum_{i=1}^3 F_i R_{2 \times 2}(\psi) D_i - \begin{bmatrix} F_{T1} \cos(\psi) + F_{T2} \cos(\psi + \frac{2\pi}{3}) + F_{T3} \cos(\psi + \frac{4\pi}{3}) \\ F_{T1} \sin(\psi) + F_{T2} \sin(\psi + \frac{2\pi}{3}) + F_{T3} \sin(\psi + \frac{4\pi}{3}) \end{bmatrix}$$

$$J\ddot{\psi} = p_1 F_1 + p F_2 + p F_3 \quad (8.24)$$

where:

$$D_1 = [01]^T, D_2 = -\frac{1}{2}[\sqrt{3}1]^T, D_3 = \frac{1}{2}[\sqrt{3}1]^T$$

$$R_{2 \times 2} = \begin{bmatrix} \cos(\psi) & \sin(\psi) \\ \sin(\psi) & \cos(\psi) \end{bmatrix}$$

and F_{Ti} satisfies the inequality $-\frac{mg}{3}\mu_{Tmax} \leq F_{Ti} \leq \frac{mg}{3}\mu_{Tmax}$ where μ_{Tmax} is the maximum static friction coefficient for the transverse wheel direction.

Substituting the equation (8.23) in (8.24), we obtain the platform dynamic model:

$$\begin{bmatrix} m\ddot{x} \\ m\ddot{y} \\ J\ddot{\psi} \end{bmatrix} = \frac{1}{r} \begin{bmatrix} -\sin(\psi) & -\sin(\frac{\pi}{3} - \psi) & \sin(\frac{\pi}{3} + \psi) \\ \cos(\psi) & -\cos(\frac{\pi}{3} - \psi) & -\cos(\frac{\pi}{3} + \psi) \\ p_1 & p & p \end{bmatrix} \begin{bmatrix} \tau_1 \\ \tau_2 \\ \tau_3 \end{bmatrix} - \begin{bmatrix} \bar{f}_1 \\ \bar{f}_2 \\ \bar{f}_3 \end{bmatrix} \quad (8.25)$$

$$= \frac{1}{r} P^T(\psi) \begin{bmatrix} \tau_1 \\ \tau_2 \\ \tau_3 \end{bmatrix} - \bar{f}$$

where:

$$\bar{f} = [\bar{f}_1 \quad \bar{f}_2 \quad \bar{f}_3]^T$$

$$\bar{f}_1 = F_{W1} \sin(\psi) + F_{W2} \sin(\frac{\pi}{3} - \psi) - F_{W3} \sin(\frac{\pi}{3} + \psi) + F_{T1} \cos(\psi) - F_{T2} \cos(\frac{\pi}{3} - \psi) - F_{T3} \cos(\frac{\pi}{3} + \psi)$$

$$\bar{f}_2 = -F_{W1} \cos(\psi) + F_{W2} \cos(\frac{\pi}{3} - \psi) + F_{W3} \cos(\frac{\pi}{3} + \psi) + F_{T1} \sin(\psi) + F_{T2} \sin(\frac{\pi}{3} - \psi) - F_{T3} \sin(\frac{\pi}{3} + \psi)$$

$$\bar{f}_3 = p_1 F_{W1} + \sum_{i=2}^3 F_{Wi}$$

and the uncertain friction force vector satisfies the inequality $\|\bar{f}\|_\infty \leq k_{max}$ with k_{max} is the least upper bound of $\|\bar{f}\|_\infty \leq k_{max}$. By defining the vectors $Z_1 = [x \ y \ \psi]$ and $Z_2 = [\dot{x} \ \dot{y} \ \dot{\psi}]$, the dynamic model can be written in the standard state space as:

$$\dot{Z}_1 = Z_2$$

$$M\dot{Z}_2 = \frac{1}{r} P^T(\psi) T - \bar{f}$$

where:

$$M = \begin{bmatrix} m & 0 & 0 \\ 0 & m & 0 \\ 0 & 0 & J \end{bmatrix}, T = \begin{bmatrix} \tau_1 \\ \tau_2 \\ \tau_3 \end{bmatrix}$$

Adaptative controller design

Using the dynamic model (8.25) and following the steps described in the articles [18] we had synthesized an adaptative controller in order to steer the robot to reach the destination pose and exactly follow desired trajectory. The desired trajectory is described as $Z_r = [\dot{x}_r \ \dot{x}_r \ \dot{\psi}_r]^T$. In this way, if the trajectory is time independent, we have a stabilization problem otherwise we have a trajectory tracking problem. We define the tracking error vector as $Z_e = Z_1 - Z_r$ and differentiating with respect to the time we obtain:

$$\dot{Z}_e = \dot{Z}_1 - \dot{Z}_r = Z_2 - \dot{Z}_r \quad (8.26)$$

Considering Z_2 as a virtual control designed as $Z_2 = -K_p Z_e + \dot{Z}_r$ where K_p is diagonal we obtain $\dot{Z}_e = -K_p Z_e + \dot{Z}_r - \dot{Z}_r = -K_p Z_e$ and the asymptotic stability of Z_e can be demonstrated selecting the Lyapunov function $V_1 = \frac{1}{2} Z_e^T M K_p^2 Z_e$ that yield to $\dot{V}_1 = Z_e M K_p^2 \dot{Z}_e = Z_e M K_p^2 (-K_p Z_e) = -Z_e M K_p^3 Z_e \leq 0$.

To achieve the controller design, the backstepping error is defined as:

$$\eta = Z_2 - (K_p Z_e + \dot{Z}_r) = Z_2 + K_p Z_e - \dot{Z}_r \quad (8.27)$$

therefore:

$$\dot{Z}_e = Z_2 - \dot{Z}_r = (Z_2 + K_p Z_e - \dot{Z}_r) - K_p Z_e = \eta - K_p Z_e. \quad (8.28)$$

In order to achieve $Z_e \rightarrow 0$ and $\eta \rightarrow 0$ when $t \rightarrow \infty$ the following adaptative law is proposed:

$$T = (P^T(\psi))^{-1} r (\hat{M} \ddot{Z}_r - (K + \hat{M} K_p) \eta - \hat{k} \text{sgn}(\eta)) \quad (8.29)$$

where $\hat{M} = \text{diag}\{\hat{m}, \hat{m}, \hat{J}\}$; $K_p = \text{diag}\{k_{p1}, k_{p2}, k_{p3}\}$; the matrix K is symmetric and positive definite and the control gain \hat{k} is a real and positive number. Using the following parameter update laws:

$$\begin{aligned} \dot{\hat{m}} &= -\lambda_m (\eta_1 \ddot{x}_r + \eta_2 \ddot{y}_r) + \lambda_m (k_{p1} \eta_1^2 + k_{p2} \eta_2^2) \\ \dot{\hat{J}} &= \lambda_J (-\eta_3 \ddot{\psi}_r + k_{p3} \eta_3^2) \\ \dot{\hat{k}} &= \lambda_k \|\eta\|_1 \end{aligned}$$

where $\lambda_m > 0$ $\lambda_J > 0$ $\lambda_k > 0$, and choosing the Liapunov function:

$$\dot{V}_2 = \frac{1}{2} Z_e M K_p^2 \dot{Z}_e + \frac{1}{2} \eta^T M \eta + \frac{1}{2\lambda_m} \tilde{m}^2 + \frac{1}{2\lambda_J} \tilde{J}^2 + \frac{1}{2\lambda_k} \tilde{k}^2 \quad (8.30)$$

we obtain:

$$\dot{V}_2 \leq -Z_e^T M K_p^3 Z_e - \eta^T K \eta \leq 0 \quad (8.31)$$

which shows that \dot{V}_2 is positive and semidefinite. Similarly, using Barbalat's lemma we can affirm that $Z_e \rightarrow 0$ and $\eta \rightarrow 0$ as time tends to infinity and the estimates \hat{m} , \hat{J} and \hat{k} are globally uniformly bounded. Therefore the globally asymptotic stability of the closed-loop error is ensured.

The experimental results were conducted with the following parameters: $m = 1800$, $J = 700$, $\lambda_m = \lambda_J = 10$, $K_p = \text{diag}\{25, 25, 25\}$ and $K = \text{diag}\{3000, 3000, 3000\}$. Where m and J , that are not expressed in standard SI units, have been used to avoid the controller start supposing a null mass and a null moment of inertia. They have been calculated just letting the controller automatically establish them while tracking various trajectories and then have been inserted in the \hat{M} matrix to avoid the increase of the great error at the beginning.

8.3.5 Other functions

As the platform component, in our design, is the only component that knows the platform position and speed in every moment, it has been provided with other useful functions to use this data to limit its working area or store them to repeat the trajectory that the user can manually "teach" to it using the Joystick.

Security functions

The platform could be stopped in any moment pushing one of the two security buttons that, using a dedicated port, directly stop the servodrivers. One of these buttons is placed on the platform, the other is remote and communicates using radiofrequency. Anyway to be even more sure when using the platform, we have implemented in the code some functions to limit the speed and the operation area.

There are two speed limiting functions. The first one reads the actual speed of the motor and compares it to the parameter *motorSpeedLimit*[m/s], if the actual speed is bigger the Platform is stopped. The second one checks the required speed before it is applied to the motors checking the input reference speed with the parameter *platformSpeedLimit*[m/s], if the reference speed is bigger, the Platform is stopped. Theses parameters can be modified by the user editing the .ops, in particular using the function: *basicConfiguration(controlMode, fixedReferenceSystem, motorSpeedLimit[m/s], platformSpeedLimit[m/s], controlInput)*.

The other security check we have implemented is about the position. We have decided that the initial platform position⁸ could represent the origin of our fixed reference system. Having

⁸This position is saved when the Platform component is started

this concept in mind, we have decided to limit the platform's operation area into a square whose coordinates can be decided by the user.

To configure this parameters the user has do edit the .ops modifying the values in the function *activateSecurityLimits(active, Xpositive, Xnegative, Ypositive, Ynegative)*. When the platform arrives in the limits, if it is controlled by the Trajectory Generator Component, it is stopped, while if it is controlled by the joystick, we have decided to block only the movement towards the limit, letting the user free to come back or follow other directions.

Autolearning function

Trying the platform, performing various demos, we have seen that sometimes it could be very useful to try a trajectory using the joystick and then make the platform repeat this trajectory alone.

To obtain this result, we used the already developed Trajectory Generator Component. All we had to do was to save, with a certain sample time, the Cartesian coordinates while the platform is controlled by the joystick. In this way, when the Platform is running it writes autonomously the file pathPoints.dat that afterwards is used by the Trajectory Generator Component to repeat the path. The user can activate or deactivate this function and set the sampling time editing the .ops, in particular modifying the parameters of the following function: *activateAutoLearning(false, samplingTime)* where the *samplingTime* is expressed in seconds.

8.3.6 Obstacle avoiding

Usually mobile platforms have to move in an environment occupied by obstacles and people too, therefore they have to take care of avoiding them. A lot of algorithms have been developed to achieve this goal. Mainly they can be divided in two big groups concerning the moment when the obstacle presence is evaluated:

- If the environment is totally known and the position of the obstacles is known even in the trajectory planning phase, the problem consists in planning an optimal trajectory avoiding the obstacles.[26]
- If the environment is supposed to be dynamical changes capable and there is no previous information about the obstacles when the trajectory is planned, the problem consist in avoiding obstacles while minimising the position error with respect to the planned path that can be seen as a desired path line (DPL)(fig. 8.7).

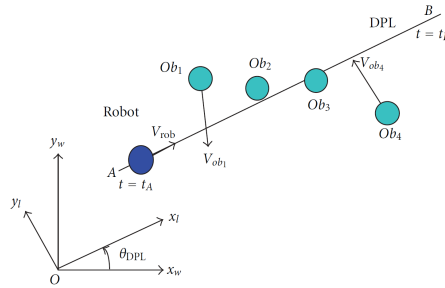

Figure 8.7: Obstacles entering in the desired path line (DPL)

Actual implementation

In the Platform component has been added a function that takes care of a “rude” obstacle avoiding. It is just a beginning solution, that should be modified/improved, whose purpose is to provide a first algorithm to test 3D cameras for obstacle avoiding.

Algorithm description

The algorithm objective is to avoid collisions with static and moving obstacles and represents a simplification of other algorithms that are of course more effective.[23] In this case only the nearest obstacle is considered whose information can be passed to Platform from the *obstacle detection system* that would consist of a 3D camera. No further prediction about the future obstacle motion is done because smart obstacles may change motion according to our platform motion.

The obstacle is represented with the coordinates of its centre and with an obstacle radius therefore every obstacle is considered as a sort of cylinder.

Obstacle avoidance is realized by changing the robot speed when it is in the *safety circle* around the obstacle (see fig.8.8). The speed is changed to describe a circle around the obstacle till the

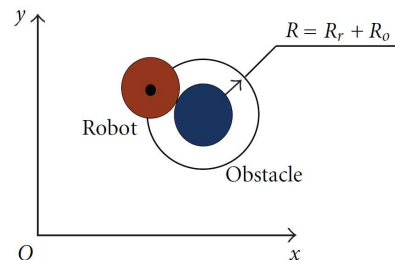

Figure 8.8: Safety circle radius

platform can go directly to the planned path without entering in the *safety circle*.

The circular speed is set to be clockwise or counter-clockwise depending on which of them minimises the speed error compared to the actual desired speed along the path. A coefficient that can be changed real-time⁹ multiplies the circular speed that also is multiplied for the *safety circle's* radius in order to increment the speed outside the desired path depending on the obstacle dimension.

The case of having two nearest objects is not considered as in this case they are considered as a single but bigger obstacle. This operation has to be done by the *obstacle detection system*. The idea is that if two objects are near the robot and the distance between them doesn't let the robot pass through them, they are considered as a single obstacle. In this project as an *obstacle detection system* isn't yet mounted, the position and the obstacle radius can be modified manually during the run-time by the user to simulate the information that will come from the automatic system.

At the moment, the algorithm doesn't take care of the dynamic constraints of the platform, therefore when the platform touches the "safety circle" it is supposed to stop immediately. It would be useful to avoid this problem and the motors' saturation that it can cause, evaluating platform's radius as composed of two components:

- a fixed component due to the distance between the Platform's centre and its further vertex;
- a variable component that would be incremented taking care of the space that the platform needs before stopping depending on the acquired speed;

In contrast with other solutions, that change the robot speed in the direction perpendicular to the *DPL* [23], this algorithm doesn't implicitly ensure that the platform reaches the target at the desired time but it can be achieved modifying real-time the circular speed coefficient.

⁹To change it real-time it has to be modified through a port. In our implementation there isn't such a port because it would have to be connected with the Orocos Component that take care of the visualisation.

Chapter 9

Environmental Analysis

Since this work is simply a software development, it does not affect the environment directly.

More or less the same approach was used to develop the different modules. The first phase always consisted in consulting books, articles and manuals and doing some tests to know the tools which would have been used in the project. This implied the use of paper (new, used or recycled) to print some essential part of documents or write notes or calculations and the use of computer to make tests or also read documents. The following phase was more centered on the development of code and tests using the computer and the platform, when useful. In this phases the use of paper may decrease (just use to print some important code) but, on the other hand, the consumption of electric energy increases.

The effects on the environment can be summarized as follows:

- Emissions in the atmosphere caused by a continuing use of the programming computer. Considering an average power consumption of 360 W for 6 months (24 day per month) and a average time of 10 hours per day, this consumption can be estimated in about 520 kWh.
- Emissions caused for the use of the platform on board PC. Considering an average power consumption of 200W and an average use of 5 hours per day in only the second part of the work (3 months), the electricity consumption can be estimated in 72 kWh.
- Emissions caused for the use of the platform. Considering an average power consumption of 3x300W and an average use of 5 hours per day in only the second part of the work (3 months), the electricity consumption can be estimated in 324 kWh.
- Paper and ink consumption to print documents in general or part of interesting code and to write notes or calculations. The paper used was recycled, written on one page or new sheets.
- Emissions as consequence of the transport used to go to the laboratory or libraries.

The last consideration to make is that all the paper, used in the project and considered useless at the end of the project itself, has been recycled.

Chapter 10

Costs Analysis

The costs deriving from this work can be divided into two groups: costs related to the physical equipment or material and those related to the staff work (composed by two doctor engineers and a new engineer.)

Physical Equipment

Physical Equipment Value

Equipment / Material	Unit Price [€]	Total Cost [€]
Platform	10.000	10.000
Joystick	50	50
PC Dell	300	300
Fungible Material (CD, Sheets of paper...)	-	30
Total	-	10.380

Where the main parts included in the platform are: 3 servomotors Yaskawa model SGMCS-07B3C11, 3 servopacks Yaskawa model SGD V-2R8AE1A, 3 option modules SGD V-OCA01A (Ether-CAT), various mechanical parts, On board PC, WiFi router.

Physical Equipment Utilization Cost

Equipment	Hours	Estimated Power [W]	Energy Consumption [KWh]	Total Cost [€]
PLatform	360	1100	396	66,53
PC Dell	1440	360	518	87
Total	-	-	-	153,53

The considered cost for a KWh is 0,168 €, as calculated from Eurostat.

Working Staff

Profession	Hours	Professional Fee [€/h]	Total Cost [€]
Senior Engineers	40	100	4.000
Junior Engineer	1008	30	30.240
Total			34.240

The cost of transport to get to the laboratory is included in the professional fee.

To estimate the cost of this project, we can suppose that the used hardware has an amortization period of three years¹ and, supposing a total use time of 2000 hours/year for the platform and 2300 hours/year for the other hardware, we can value the usage cost per hour. In this way we can calculate the cost of our specific project that depends from the hardware utilization:

$$platform_{using_cost} = \frac{10.000}{3 \times 2000} \times 360 = 600$$

$$joystick_{using_cost} = \frac{50}{3 \times 2300} \times 1440 = 10$$

$$DELL_PC_{using_cost} = \frac{300}{3 \times 2300} \times 1440 = 63$$

$$platform_{using_cost} + joystick_{using_cost} + DELL_PC_{using_cost} = 673 \text{ €}$$

Therefore the estimated cost of this project can be around 35.066 €, which can be a hypothetical budget to carry out this work.

¹That is the estimated developing time for the whole “Omnidirectional Mobile Manipulator” project.

Chapter 11

Results

A software has been implemented to control the omnidirectional platform of the *Barcelona Mobile Manipulator* ensuring real-time performances, satisfying the requirements of the application explained in chapter 4.

The first part of the software package allows the user to communicate with various ETherCAT slaves providing their data into the Orocos middleware. To achieve that, the SOEM library has been used to manage data exchange through ETherCAT. In this application three identical slaves are used, but simply adding a few lines of slave dependent code, other slaves can be controlled.

The slaves synchronisation has been obtained by the use of the DC clock mechanism and cycletime till $500\mu s$ has been successfully tested allowing a sampling frequency of 2KHz (fig. 11.1).

The second part of the developed software, the so called “Orocos control components” takes care properly of controlling platform movements generating the necessary references (Joystick component or Trajectory Generator component) and using this data to perform the desired movements calculating the necessary speed for every motor (Platform component).

As required the platform could be controlled by the joystick or tracking a predefined trajectory. The data from the joystick have been handled using the libusb library while the pathpoints that the trajectory Generator component uses are linked using a third grade polynomial.

The Platform component has been equipped with various functions to manage collisions in the right way avoiding going out from the operation area and avoiding “defined” obstacles. Moreover this component contains two different controllers that can ensure a correct trajectory tracking. One of these controller sets a reference speed while the other one, that has required a platform dynamic model, is an adaptative controller that generates a torque reference.

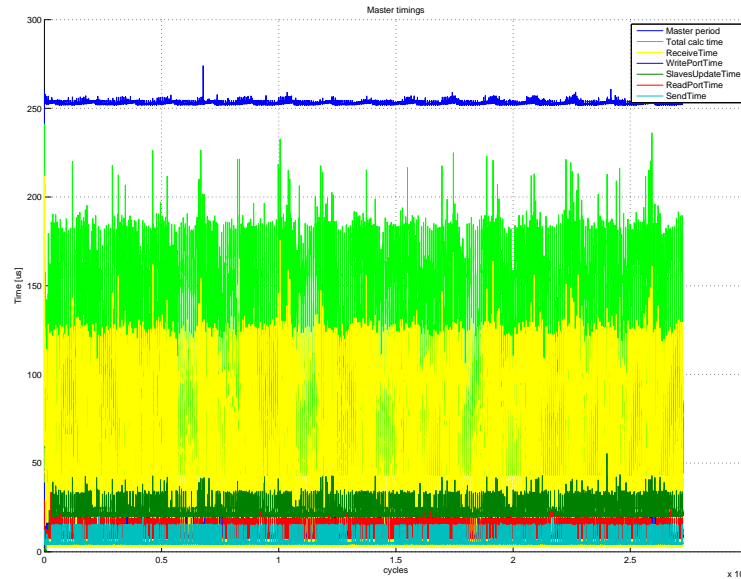

Figure 11.1: EtherCAT Master time evaluation

These controllers have demonstrated to work very well (see fig. 11.2¹) but measurements about the position along the time haven't been done yet, requiring material that was not available, like a fixed camera parallel to the floor. Therefore we have measured only the final positions that doing various maneuvers with a maximum speed of 0.6 m/s² has shown a maximum error of 3 mm. We have to remember that this error is present even if the controllers are working well because at the moment the position data they receive proceed only from the encoders and therefore is slipping dependent.

In the tests made so far, the software does not present any strange behaviour. When we were using a previous kernel (the actual one is Xenomai 2.5) we experienced time-out error in the slaves when connecting an usb camera. This was solved blocking the memory that the Orocos components use.

To visualise the platform data such as motor speeds and torque, platform speed, etc. . . we had configured Kst to work with the data proceeding from the Orocos Reporter component.

Next screen-shots (fig. 11.3 and fig. 11.4) show platform data while it is tracking a trajectory using the adaptative controller. Figure 11.5 shows the platform development phases.

¹The detected trajectory is called that way because it hasn't been measured with external instruments. It is the result of the calculations executed with encoders data

²The maximum speed has been of 0.5 m/s but all the trajectories have been travelled using smooth speed profiles. Otherwise the detected error is sensibly bigger.

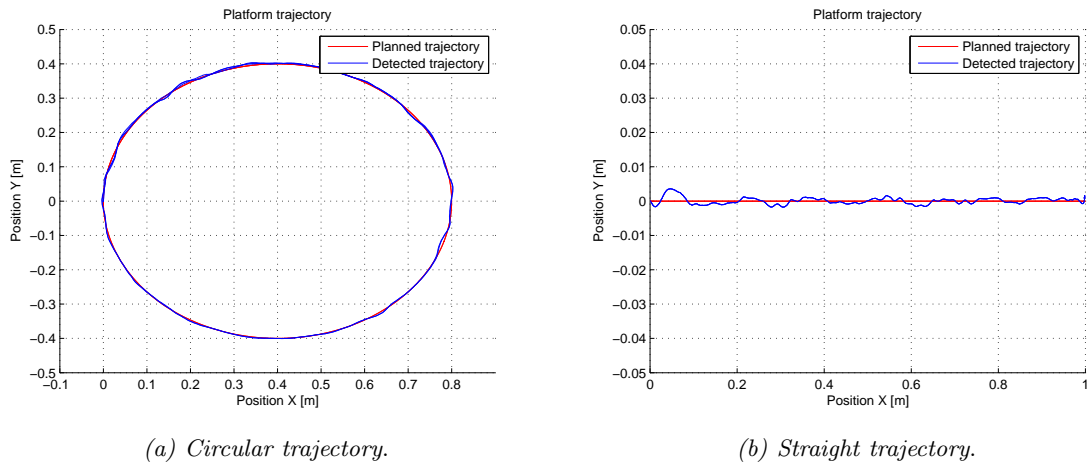

Figure 11.2: Planned and “detected” trajectories using the adaptive controller.

Some videos have been made to show better how it works. They are attached in the accompanying CD.

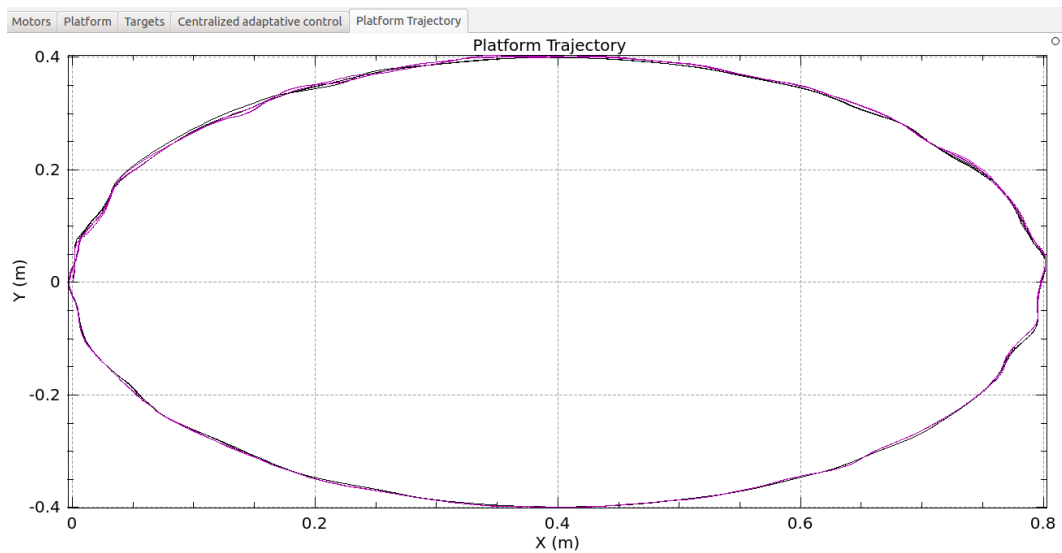
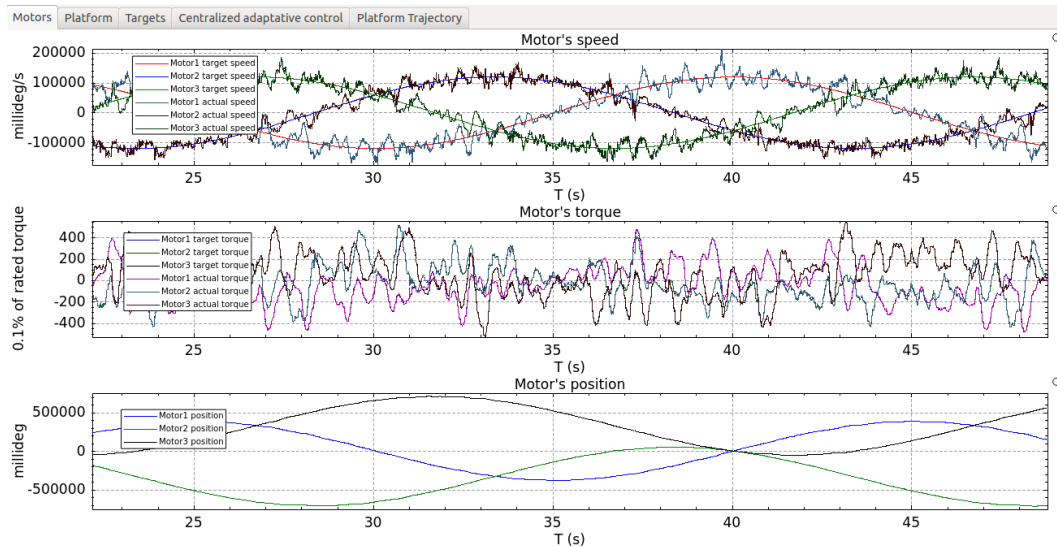
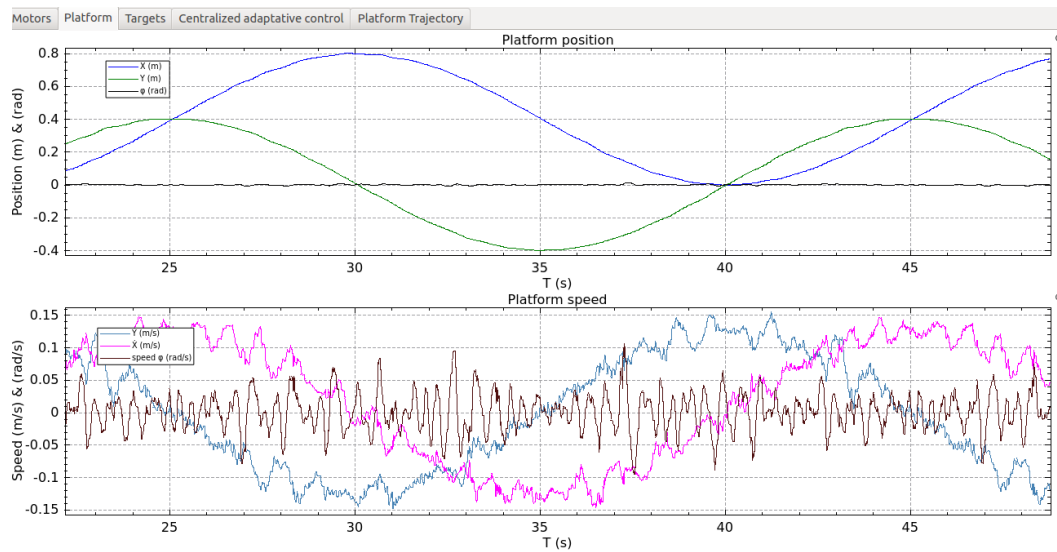

Figure 11.3: The platform position can be verified in every moment. It is useful to compare it with external instruments measurements.



(a) Motor data: speed, torque and position.



(b) Platform data: position and speed.

Figure 11.4: Platform data that can be visualized, while the platform is running, with a few milliseconds delay, using Kst.

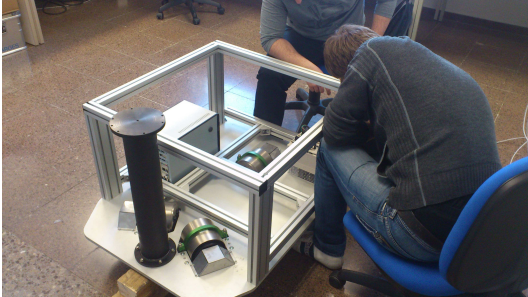

(a) The platform when just arrived.

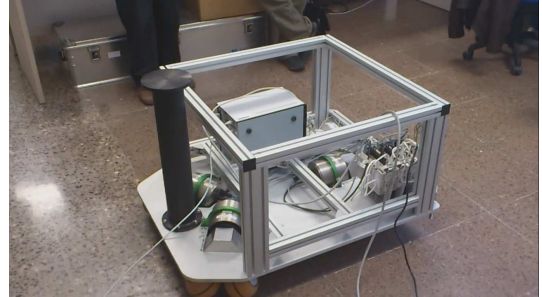

(b) We have looked for the motor settings more suitable to our application and performed the necessary wiring.



(c) The platform, equipped with the Kuka lightweight robot, prepared for the presentation day.



(d) The platform controlled by the joystick.

Figure 11.5: Platform developing

Chapter 12

Conclusions

All the objectives of the beginning have been attained with good results. This work can be considered also a sort of experiment, as it has been the first attempt to move and control the platform of the *Barcelona Mobile Manipulator*, using Orocos managing EtherCAT communication for the first time in the IOC. It is mainly for these reasons that we have decided to document as better as possible the used parts of Orocos as well as to introduce the reader to EtherCAT, explaining the protocol basis and terminology.

Orocos turns out to be a very good tool to create robotic applications. It enables the user to accomplish control task relatively quickly ensuring data consistence in every moment using Ports to link the various control components that you need. Moreover the same source code could be linked against the real-time version of the RTT or against the standard GNU/Linux version of the same library. This implies only the change of one line in the build system.

The help of the Orocos mailing list has been fast and very useful. Its powerful KDL library can be used to control manipulators such as the Kuka lightweight but still misses the code specifically oriented to control mobile platforms that can only move in 2 dimensions. Anyway great interest in this field has been expressed in the mailing list[7] promising great future developments.

SOEM gives the user the possibility of controlling EtherCAT devices very simply. In the previous version it lacked a bit of documentation and for a novel user it wasn't so easy to obtain a good knowledge of the library, fortunately we have to say that its mailing list¹ has been very useful to comprehend it. Anyway with version 1.2.8 a lot of work has been done to organise files and information better. Moreover a small but very useful tutorial has been added.

¹Its important to underline that doing this project we have found some bugs that had been reported writing to the SOEM mailing list in order to allow their correction. The bugs we found in SOEM and that have already been fixed are explained in chapter 6.1.6.

Our SOEM basic documentation intent has been done collecting the information present in the list and organising it to make easier for the reader comprehend the various structures and functions that it provides. The idea is that with this basic documentation about EtherCAT and SOEM the reader can comprehend the basic aspects of the communication task and will be able to understand and modify the code more easily.

About the developed software

A transparent EtherCAT master

Despite being a basic version, the developed “Orocos EtherCAT communication components” software package can be defined a good tool for the general task of controlling various EtherCAT devices, allowing the use of different slaves just writing a small part of slave dependent code.

It acquires an “added-value” inside the bigger project whose target is the collaboration of more than a mobile manipulator to move objects. It manages the EtherCAT communication between the control PC and the servodrivers. In this way next developers can prescind from how it is done, dedicating all the effort to coordination and control purposes.

The platform control components

The “Orocos control components” package can be easily used to carry out various platform demos in order to test how BMM platform works. Moreover it has been useful to demonstrate that “Orocos EtherCAT communication components” works in the correct way and it showed the BMM platform potentialities: its very good maneuverability and its odometric accuracy.

It is easily configurable giving the user the possibility of controlling the platform in two ways: in a more intuitive way with the Joystick or with a previously planned trajectory that can be autolearned while controlled in the previous mode.

Finally, another positive consideration can be done about the controllers that had tested the superior odometric accuracy and the good skid resistance of the omnidirectional spheric wheels.

Chapter 13

Future Work

Using this work as basis, there are many possibilities to add features and expand the application's field of various components. Some of them have already been considered as natural continuation of this project. Future work can be divided into two parts: EtherCAT master performance comparison and further developing; Orocos platform component developing, mainly to make the platform work together with the Kuka lightweight manipulator.

Orocos EtherCAT master developing

About the EtherCAT communication part it would be interesting to compare the performances between the developed Master and the SOEM/Orocos Master.

If the second one would be considered better for time and/or memory performances it would be useful to extend the Orocos' marshalling plug-in such that it can marshal the properties of another service (a slave) of the same component. In this case the map that is used to create the correct service for every slave would have to be redesigned in order to use manufacturer ID and device ID as keys values and not slave's name.

If our Master's performances where considered adequate, the possibility of handling the different EtherCAT errors that SOEM can detect should be considered. The integration of slave's recovery function, already provided by SOEM, would be useful as well. Moreover the possibility that is the Master that internally takes care of Slaves' Deployment can be considered.

In any case the performance analysis of the net as well as the Master's Jitter when using DC clock should be analysed using Wireshark [30] that is a protocol analyser really suitable to EtherCAT.

Other Orocos components developing

About the Platform component a lot of future work could be done, mainly in three areas:

1. **Odometry using other sensors** As explained we have performed a basic odometry using only the information that proceeds from the motors' encoders. This can cause a lot of errors when slippage phenomena occur, therefore it would be really useful to integrate this information with the information proceeding from other sensors such as cameras or other laser sensors that can measure the platform travelled distance.
2. **Platform and manipulator coordination** One very interesting future work would be the developing of an Orocos Component, that unifying the platform and the Kuka control, allows their coordination and the use of the redundant grades of freedom that the mobile manipulator can offer.
3. **Trajectory tracking control** Other controllers to track a trajectory could be developed, such as controllers with different adaptative laws. Moreover as the platform is equipped with a robotic arm, the trajectory tracking could be totally redefined thinking that the arm TCP has to follow a defined trajectory, while the platform can assume different possible positions because of redundant degree of freedom.
4. **Obstacle avoiding** The obstacle avoiding function could be developed basing on the hardware with which the platform will be equipped and different algorithms could be implemented such as the one described by Sahraei et al. [26]. Moreover other algorithms can be applied during the trajectory generation if obstacles' positions are known from the beginning.

About the trajectory Generator component, various future developments are possible. From an Orocos point of view it would be useful that a trajectory generator oriented to omnidirectional platforms were integrated in the KDL library. While thinking only to develop the existent component it would be interesting to have the possibility of using spline functions to link the various points. In this case the computational effort would be greater and would be done entirely at the beginning of the trajectory. It would be especially interesting using B-spline that are based upon Bézier curves.

Appendix A

EtherCAT

This section has been deigned to provide a relatively fast and simplified introduction to the EtherCAT protocol in order to comprehend the SOEM commands easily, to understand the various kind of data and how they are addressed to the right slave. It can be especially useful to understand the difference between PDO data and SDO data and the synchronisation mechanism of DCclock.

A.1 EtherCAT introduction

EtherCAT is a fast, low cost, and flexible Ethernet network protocol. It consists of a master with several slaves. The computer on which the controller runs is the Master, while devices that make data of connected I/O devices available for the master are called slaves. [14]

Origins

EtherCAT has been released in 2003 by Beckhoff. In 2004, Beckhoff helped to create a new group to promote the EtherCAT protocol and its efforts led to the EtherCAT Technology Group (ETG) to which they donated the rights of EtherCAT too. The ETG is a global organization in which OEM, End Users and Technology Providers join forces to support and promote the further technology development.

Nowadays Beckhoff provides a large number of different terminals that make it possible to access from almost any I/O device. Anyway EtherCAT is an open protocol, therefore everybody can make its own terminal. [14]

Protocol functional principle

Going on analysing the protocol we have to know that EtherCAT commands are transported in the data area of an Ethernet telegram and can either be coded via a special Ether type or via UDP/IP. While the first variant is limited to an Ethernet subnet the second one, designed for less time-critical applications, enables normal IP routing.

Each EtherCAT command consists of an EtherCAT header, the data area and a subsequent counter area (working counter). This working counter is incremented by all EtherCAT devices that were addressed by the EtherCAT command and have exchanged associated data.

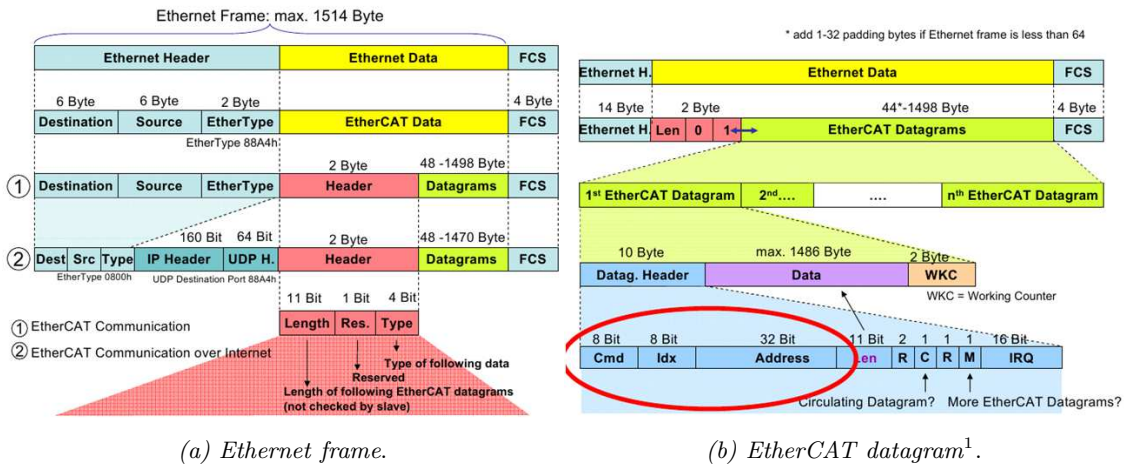

Figure A.1: EtherCAT datagrams inside a standard Ethernet frame

Ethernet telegram processing

Each Ethernet “data pack”, called telegram, is processed directly “on the fly”. While the telegram (delayed by only a few bits) is already passed on, the slave recognizes relevant commands and executes them accordingly. Each slave processes the incoming telegrams directly and extracts/inserts the relevant user data and transfers the telegram to the next EtherCAT slave (fig.A.2). The last EtherCAT slave sends the fully processed telegram back, so that it is returned by the first slave to the control as a kind of response telegram.

Telegram processing is done within the hardware and is therefore independent of the response times of any microprocessors that may be connected. Each device has an addressable memory of 64 kB that can be read or written, either consecutively or simultaneously.

The Telegram processing functional principle of EtherCAT can be explained using the analogy of a fast train expressed in three points:

1. With EtherCAT, the "train" (the Ethernet Frame) does not need to have the same combination of cars (datagrams) in each cycle.
2. The person (data) in the car (datagram) is identified by the car number (datagram header) and the offset, and then removed or inserted on the fly.
3. If more process data are to be communicated more than fit within one train (frame) (1488 bytes), a second train is used within the same communication cycle.

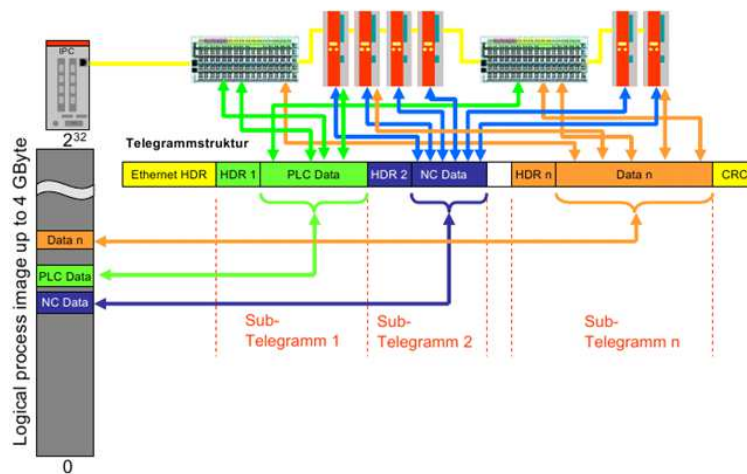

Figure A.2: EtherCAT logical addressing

Performance

Thanks to FMMU in the slave nodes and DMA access to the network card in the master, the complete protocol processing takes place within hardware and is thus independent of the run-time of protocol stacks, CPU performance or software implementation.

The update time for 1000 distributed I/Os is only 30 μs . Up to 1486 bytes of process data can be exchanged with a single Ethernet frame - this is equivalent to almost 12.000 digital inputs and outputs. The transfer of this data quantity only takes 300 μs . The communication with 100 servo axes only takes 100 μs . During this time, all axes are provided with set values and control data and report their actual position and status. The distributed clock technique enables the axes to be synchronized with a deviation of significantly less than 1 microsecond.

Topology

EtherCAT supports almost any topology: line, tree or star. The Fast Ethernet physics enables a cable length of 100 m between devices while the E-Bus line is intended for modular devices. The size of the network is almost unlimited since up to 65535 devices can be connected.

A.2 EtherCAT terminology

ESC

The ESC (fig. A.3) is a chip for EtherCAT communication. The ESC handles the EtherCAT protocol in real-time by processing the EtherCAT frames on the fly and providing the interface for data exchange between EtherCAT master and the slave's local application controller via registers and a DPRAM. The ESC can either be implemented as FPGA (Field Programmable Gate Array) or as ASIC (Application Specific Integrated Circuit). The performance of the EtherCAT communication does not depend on the implementation of the application software in the host controller. In turn, the performance of the application in the host controller does not depend on the EtherCAT communication speed. [4]

Another feature of the ESC is to provide data for a local host controller or digital I/Os via the Process Data Interface (PDI). Process data and parameters are exchanged via a DPRAM in the ESC. To ensure data consistency, appropriate mechanisms are provided by the ESC hardware such as SyncManagers.

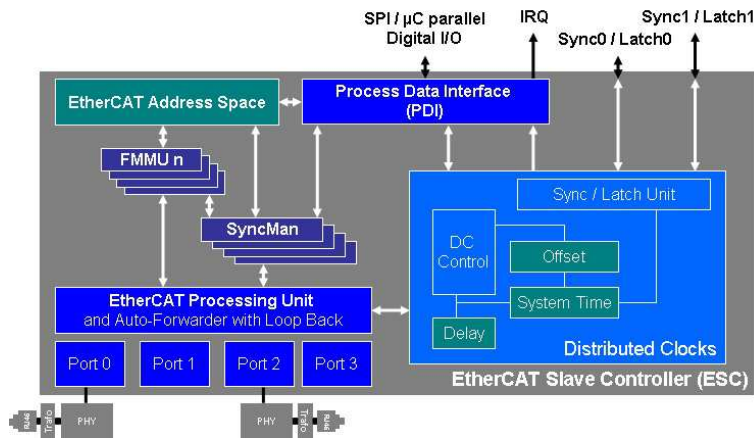

Figure A.3: EtherCAT Slave Controller (ESC) with the Distributed clock Unit

SII

The EEPROM (fig. A.4) (Electrically Erasable Programmable Read-Only Memory, also called Slave Information Interface, SII) contains hardware configuration information for the ESC which is loaded to the ESC's registers during power-up. [4]



Figure A.4: Slave EPROM structure

FMMU

Fieldbus Memory Management Units (FMMU) convert logical addresses into physical addresses by means of internal address mapping. Thus, FMMUs allow to use logical addressing for data segments that span several slave devices: one datagram addresses data within several arbitrarily distributed ESCs. Each FMMU channel maps one continuous logical address space to one continuous physical address space of the slave. The access type supported by an FMMU is configurable to be either readable, writable, or readable/writable (For an example see table A.1).

FMMU Setup

1. Master reads hardware configuration including input and output data length of each slave
2. Master organizes mapping of process data using SDO.

3. Master distributes information (start address etc.) for every slave about where process data in logical process image is provided.
4. Process data communication starts

Table A.1: FMMU example: map 6 bits from logical address 0x14711.3 to 0x14712.0 to the physical register bits 0x0F01.1 to 0x0F01.6

FMMU config. register	FMMU reg. offset	Value
Logical start address	0x0:0x3	0x00014711
Length (Byte)	0x4:0x5	0x0002
Logical Start bit	0x6	0x03
Logical Stop bit	0x7	0x00
Physical Start Address	0x8:0x9	0x0F01
Physical Start Bit	0xA	0x01
Type	0xB	Read and/or Write
Activate	0xC	1 (Enable)

SyncManager

Since both the EtherCAT network (master) and the PDI (local μC) access the DPRAM in the ESC, the DPRAM access needs to ensure data consistency. The SyncManager is a mechanism to protect data in the DPRAM from being accessed simultaneously. If the slave uses FMMUs, the SyncManagers for the corresponding data blocks are located between the DPRAM and the FMMU. EtherCAT SyncManagers can operate in two modes:

- **Mailbox Mode**

The mailbox mode implements a handshake mechanism for data exchange. EtherCAT master and μC application only get access to the buffer after the other one has finished its access. When the sender writes the buffer, the buffer is locked for writing until the receiver has read it out. The mailbox mode is typically used for application layer protocols and exchange of acyclic data (**SDO**) (e.g. parameter settings)(fig. A.5).

- **Buffered Mode**

The buffered mode is typically used for cyclic data exchange, i.e. process data (**PDO**) since the buffered mode allows access to the communication buffer at any time for both sides, EtherCAT master and μC application. The sender can always update the content of the buffer. If the buffer is written faster than it is read out by the receiver, old data is dropped.

Thus, the receiver always gets the latest consistent buffer content which was written by the sender.

It can be noted that SyncManagers running in buffered mode need three times the process data size allocated in the DPRAM (fig. A.5).

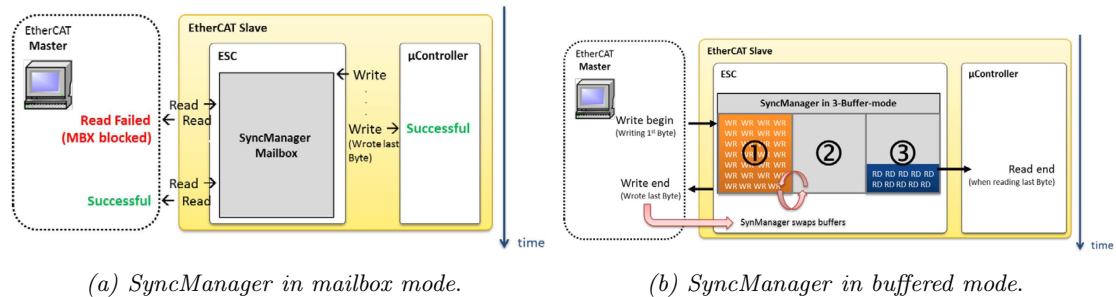

Figure A.5: SyncManager overview

EtherCAT State Machine (ESM)

Every EtherCAT slave device implements the EtherCAT State Machine (ESM) (fig. A.6) that governs the slave's functions as, in every moment, the actual state defines the available range of functions.

Four mandatory and one optional state are defined for an EtherCAT slave: Init, Pre-Operational, Safe-Operational, Operational, Bootstrap (Optional). For every state change a sequence of slave specific commands have to be sent by the EtherCAT master to the EtherCAT slave devices.

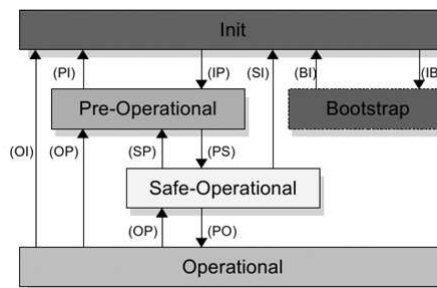

Figure A.6: EtherCAT State Machine

Available functions for every EtherCAT State

- **Init:** *Master:* Initial state. *Slave:* Initial state after power-on. *Communication:* No mailbox communication and process data exchange.

- **Pre-Operational:** *Master:* Initialization of Sync Manager channels for mailbox communication during the transition from Init to Pre-Operational. *Slave:* Validation of Sync Manager Configuration during the transition from Init to Pre-Operational. *Communication:* Mailbox communication but no process data exchange.
- **Safe-Operational:** *Master:* Initialization of Sync Manager channels for process data exchange, initialization of FMMU channels, PDO mapping/assignment (if the slave supports configurable mapping), DC configuration and initialization of device specific parameter which differ from the defaults during the transition from Pre-Operational to Safe-Operational. *Slave:* Validation of all configured values during the transition from Pre-Operational to Safe-Operational. *Communication:* Mailbox communication and process data exchange but the slave keeps its outputs in a safe state while the input data is updated cyclically.
- **Operational:** *Master:* Fully operational. *Slave:* Fully operational. *Communication:* Mailbox communication and process data exchange is fully working.
- **Bootstrap:** *Master:* Optional state which can only be entered from Init. *Slave:* Optional state which can only be entered from Init for a firmware update. *Communication:* Limited mailbox communication (only the FoE protocol is supported) and no process data exchange.

Object Dictionary

The CANopen Object Dictionary (OD) is an ordered grouping of objects; each object is addressed using a 16-bit index. To allow individual elements of structures of data to be accessed an 8-bit subindex has been defined as well. For every slave in the network an OD exists. The OD contains all parameters describing the device and its network behaviour.

Distributed clock

In EtherCAT, distributed clock enable all fieldbus devices to have the same time. A particular device contains the reference clock², which is used to synchronize the clocks of the other devices. To this end, the control sends a special telegram at certain intervals (as required in order to avoid the slave clocks diverging beyond specified limits), in which the bus device containing the reference clock enters its current time. The fieldbus devices with slave clocks then read the time from the same telegram.

²The reference clock can be the EtherCAT master's clock or not. It depends on which variant is chosen during the implementative phase. The two possibilities are: force DC time to sync with that of the master (require a master with a good clock) or synch Master's loop to the DC System Time. Usually, in this case, the clock of the first slave that is DC capable is chosen as the reference clock.

This mechanism has the final objective to make independent the moment when the Ethernet frame passes through the slave from the time to whom the read data³ refer and/or the written data are applied and could be optionally implemented inside the slave in a part of the ESC (fig. A.3)

Free running, Synchronous with SM event and Sync0

The Distributed clock mechanism ensures the best synchronization but EtherCAT provides three possibilities to synchronise slaves that can be chosen writing the dictionary objects 0x1C32/1C33.

When the subindex 1 of these objects is set to 0 (default) the sync manager will be configured for *free running mode*. When the master sends an EtherCAT packet to write/read the process data to/from the drive, the data it will write/receive will be from the most recent servo cycle. In “Free Run” mode the local cycle operates independent of the communication cycle and/or the master cycle.

When the subindex 1 of these objects is to 1 (default) the sync manager will be configured for Synchronous with SM event. The local cycle is started when the SM2 event [with cyclical outputs] or the SM3 event [without cyclical outputs] is received. Using this mode, the slave will update the input/output process data available for the master to read on every slave update, that is every time an Ethernet frame passes through it. If the outputs are available, the slave is generally synchronized with the SM2 event. If no outputs are available, the slave is synchronized with the SM3 event, e.g. for cyclical inputs.

When the subindex 1 of these objects is set to a value of 2, the sync manager will be placed in SYNC0 synchronization mode. In this mode, the drive will sample the output/input data at the time of the SYNC0 pulse, and update the buffers used to transmit/receive this data to the master shortly after that time. Therefore the master has two advantages:

1. it can read data back and know what the state of the drive was at the SYNC0 time
2. it is allowed to transmit the data intended to be used at SYNC0 time early, and the slave will not use the data until the SYNC0 signal occurs.

Using the second and the third synchronisation mode, it is possible to set an offset to shift the *input latch* and *output valid* events with respect to the synchronization pulse reference.

³Data read from the slave and written in the datagram.

How it works

To measure the offset times, the EtherCAT master sends a broadcast read datagram to a special address in all ESCs during the startup phase that causes each slave to record the time when the telegram is received (based on its local clock) in both directions. The master then reads the stored times as a basis for the calculation. These measuring cycles take place several times for all EtherCAT slaves. This enables the EtherCAT master to create a very precise map of the topology in relation to the frame delays between the EtherCAT slaves. [2] The following effects must be taken into account by the distributed clock control in the EtherCAT master⁴:

- Offset compensation of each slave relative to the reference clock. After system start-up the local clocks may start with different start values.
- Offset compensation of the reference clock relative to the master clock. To be taken into account during system start-up.
- Propagation delay measurement: Measurement of the offset times depending on the number of devices, cable lengths, dynamic changes in the configuration, etc.
- Drift compensation/drift correction. Each slave clock usually has its own source (quartz, PLL, ...), which means that offset times do not remain constant over a prolonged period (minutes, days). Drift correction deals with this irregularity.

Avoiding jitter⁵ caused issues using sync0 and offset

It's very common in an EtherCAT system for the master to run on a complex PC operating system, and therefore it doesn't have the high degree of real time performance that the slaves ensure. In such cases there can be a significant amount of timing jitter on the process data messages that the master sends.

For example, if the master has +/- 100 μ s of jitter on its PDO transmission timing, then the slave may receive the process data update anywhere from 150 μ s before SYNC0 to 50 μ s after SYNC0. Configuring the slave to use SYNC0 synchronization mode can resolve the problems caused by timing jitter in the master.

In this mode the master can compensate for its worst case timing jitter by transmitting the process data to the slaves sufficiently early to ensure that the data will be received before the

⁴ETG.1400 gives an example for the clock synchronization initialization, containing propagation delay measurement, Offset compensation to the Reference clock and drift compensation

⁵Jitter is the undesired deviation from true periodicity of an assumed periodic signal in electronics and telecommunications

SYNC0 signal. The slaves will not use the process data received until the SYNC0 pulse, so the system can remain well synchronized even with a significant amount of timing jitter in the master.

For example, in a system with a cycle time of 1ms and $\pm 100 \mu\text{s}$ of timing jitter on the master, the master could be configured to transmit its process data with a 500 μs offset (half the cycle time) from the SYNC0 time on the slaves. This would ensure that the slave devices received the process data of the SYNC0 update “well clear”. [10]

Configuration files

EtherCAT Slave Information File

Every EtherCAT device must be delivered with an EtherCAT Slave Information file (ESI), a device description document in XML format. Information about device functionality and settings is provided by the ESI and it could be used by the configuration tool to compile network information (ENI) in offline mode.

EtherCAT Network Information File

The ENI file describes the network topology, the initialization commands for each device and the commands which have to be sent cyclically. The ENI file could be provided to the master in order to provide an easier and faster configuration. Then the master would send data to slaves according this file. Its use is not compulsory but could automate a part of the master’s configuration without reading every slave’s information from the SII⁶.

A.3 Message syntax

EtherCAT can provide the same communication mechanisms as the familiar CANopen mechanisms: object dictionary, PDO (process data objects) and SDO (service data objects).

Service Data Objects (SDO)

The Service Data Object (SDO) are used to access the Object Dictionary of a device. The requester of the OD access is called the Client and the EtherCAT device, whose OD is accessed and services the request, is called the Server. A Client request is always confirmed by a reply from the Server. [6]

⁶This tool isn’t officially provided in SOEM library yet. But a part of the slave depending information could be manually added to the file `ec_configlist.h` 6.1.3

The object dictionary values can be larger than the 8 byte (limit of CANframe) because the SDO protocol implements segmentation and de-segmentation functions. There are 3 mechanisms for SDO transfer depending on the Data size: Expedited (Data <=4 byte), Normal(4 Byte < Data < MBX size), Segmented (Data > MBX size) [17]

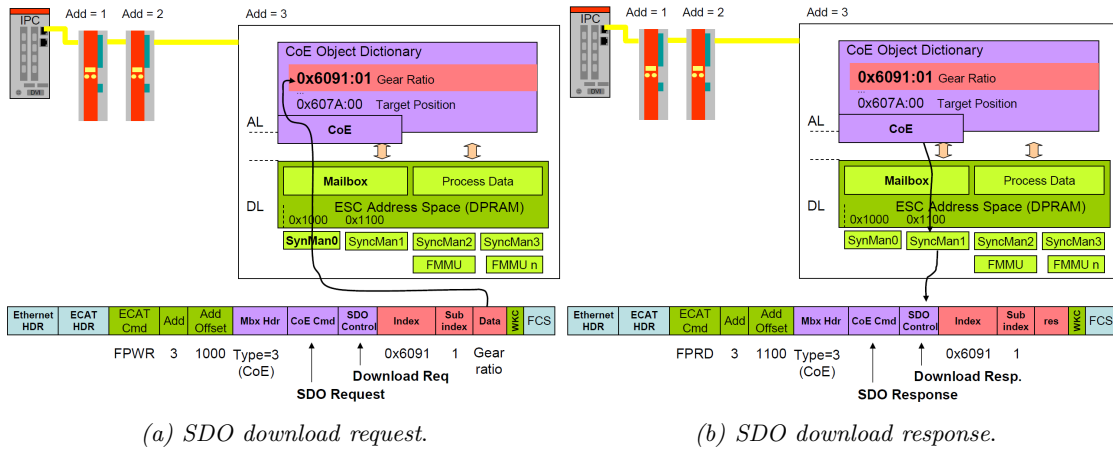

Figure A.7: SDO read: download request and download response

Process Data Objects (PDO)

Process Data Objects are used to transfer real-time data among various nodes. Data are transferred from one (and only one) producer to one or more consumers. One PDO can contain multiple object dictionary entries. The objects within a PDO are configurable using the mapping (see section A.3) and the parameter object dictionary entries (fig. A.8). There is a maximum of 64 bits for PDO. There are two kinds of PDO:

- Transmit PDO: reads data from device
- Receive PDO: sends data to device

PDO mapping

To configure how many and which object dictionary entries have to be cyclically updated using PDO, the user has to send a sequence of SDO that "map" all the desired variables⁷ in the objects that would be transmitted using PDO. The PDO mapping procedure (fig. A.8) could be performed only when the slave is in pre-operational state. The objects mapped in the PDO input could be different from the objects of the PDO output.

⁷Every dictionary entry if it is readable and writeable could be seen as a variable.



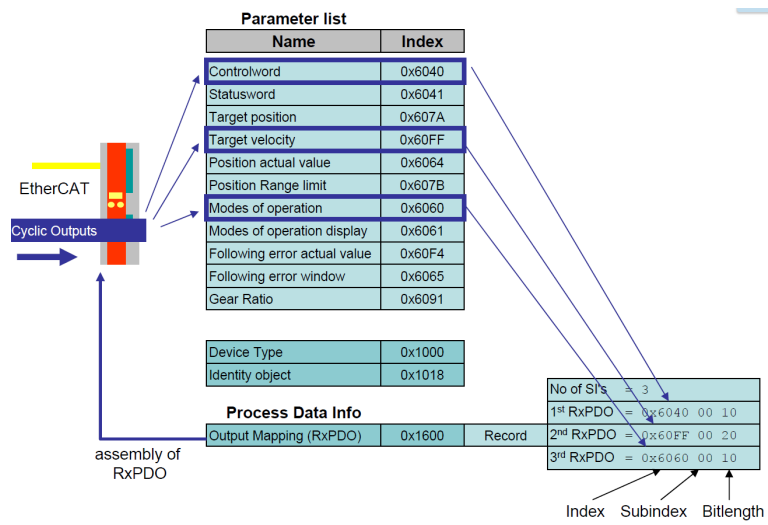

Figure A.8: An example of RxPDO mapping

A.4 EtherCAT commands

These are the EtherCAT commands [3].

Table A.2: EtherCAT Command

CMD	Abbr.	Name	Description
0	NOP	No Operation	Slave ignores command
1	APRD	Auto Increment Read	Slave increments address. Slave puts read data into the EtherCAT datagram if received address is zero.
2	APWR	Auto Increment Write	Slave increments address. Slave writes data into memory location if received address is zero.
3	APRW	Auto Increment Read Write	Slave increments address. Slave puts read data into the EtherCAT datagram and writes the data into the same memory location if received address is zero.
4	FPRD	Configured Address Read	Slave puts read data into the EtherCAT datagram if address matches with one of its configured addresses
5	FPWR	Configured Address Write	Slave writes data into memory location if address matches with one of its configured addresses
6	FPRW	Configured Address Read Write	Slave puts read data into the EtherCAT datagram and writes data into the same memory location if address matches with one of its configured addresses
7	BRD	Broadcast Read	All slaves put logical OR of data of the memory area and data of the EtherCAT datagram into the EtherCAT datagram. All slaves increment position field.

Table A.3: EtherCAT Command (part 2)

CMD	Abbr.	Name	Description
8	BWR	Broadcast Write	All slaves write data into memory location. All slaves increment position field.
9	BRW	Broadcast Read Write	All slaves put logical OR of data of the memory area and data of the EtherCAT datagram into the EtherCAT datagram, and write data into memory location. BRW is typically not used. All slaves increment position field.
10	LRD	Logical Memory Read	Slave puts read data into the EtherCAT datagram if received address matches with one of the configured FMMU areas for reading.
11	LWR	Logical Memory Write	Slave writes data into memory location if received address matches with one of the configured FMMU areas for writing.
12	LRW	Logical Memory Read Write	Slave puts read data into the EtherCAT datagram if received address matches with one of the configured FMMU areas for reading. Slave writes data into memory location if received address matches with one of the configured FMMU areas for writing.
13	ARMW	Auto Increment Read Multiple Write	Slave increments address. Slave puts read data into the EtherCAT datagram if received address is zero, otherwise slave writes the data into memory location.
14	FRMW	Configured Read Multiple Write	Slave puts read data into the EtherCAT datagram if address matches with one of its configured addresses, otherwise slave writes the data into memory location.

Appendix B

User Manual

In this section basic informations about how to start the application are provided. This part is thought to be stand alone to allow a quick use of our components if the user is not interested in focusing how they are implemented.

The basic Orocos commands to compile, to install (see section 6.2.2) and to deploy (see section 6.2.3) have to be known. After having compiled and installed the needed components the user can deploy them using one of the two provided .ops. They differ for the reference generation because in one case speed reference is generated by the Joystick while in the other one by the Trajectory Generator. Both files can be easily edited to change the configurations parameters.

Using these .ops the Orocos Component control scheme that we obtain can be seen in figure B.1. Looking at this figure, in the left part you see how the communication with the connected slaves is managed. It is performed by the Master Component that through SOEM and the Operating System communicates with the NIC¹ where the Ethernet cable is connected.

In the right part of the figure the Orocos implied Components are represented with the data² that they transmit. The variables that appear are: Z_r the vector that contains the Cartesian reference positions, speeds and accelerations of the platform; ϑ_i , ω_i , τ_i the variables³ that are exchanged between the Platform and the slaves.

If the user is interested in using only the EtherCAT communication part, implementing the component, we called platform, in another way, he has to connect the input and output port of every slave. The data type of these ports is explained in `slave_specific_structures.h` inside the

¹Network Interface Controller

²It is important to underline that the ports between the Master and the slaves transport the same data transported between the Platform and the slaves, but these data are packed in a different way, in order to keep the Master transparent.

³The reference values go from the Platform to the slaves while the detected ones go from the slaves to the Platform.

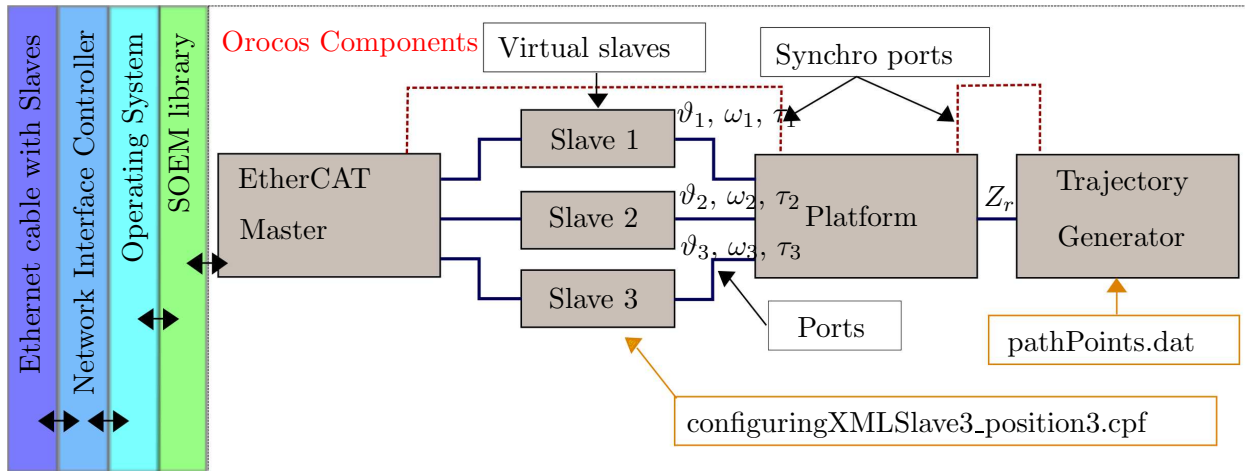

Figure B.1: Our OrocOS components structure: while normal *ports* transport data between components *synchro ports* are OrocOS Eventports 6.2.4 that are used for the synchronisation. [Trajectory Generator can be replaced with Joystick when required]

The orange borders indicate the files that these components can load to set the properties or to know the pathpoints.

soem_SGDV component folder. In this case the needed part of the .ops files is only the first one, where the Master and the slaves are configured.

Using the Joystick

The .ops configuration file that has to be used when you want to control the platform using the joystick is:

Control_by_Joystick.ops

```

##### EtherCAT Master Part #####
import ("soem_SGDV");
import ("soem_master");

//Load the components we are going to use
loadComponent("Slave1", "soem_master::soem_SGDV");
loadComponent("Slave2", "soem_master::soem_SGDV");
loadComponent("Slave3", "soem_master::soem_SGDV");
loadComponent("Master", "soem_master::SoemMasterComponent");

//To use DC clocks the period has to be 0 to let internal functions ensure
//synchronism.If you don't desire to use DCclock set the period in seconds.
setActivity("Master",0,10,ORO_SCHED_RT);

//If in the previous line you decided to use DC clocks you need to let the Master
//know the sync0 period you are going to set in your slaves.
set Master.cycletime=250000; //The period has to be set in ns[0 to not use DC].

//This part is important for "real-virtual" slave matching
connectPeers("Master", "Slave1");
connectPeers("Master", "Slave2");
connectPeers("Master", "Slave3");

//Slaves are runned using MasterSlaveActivity
setMasterSlaveActivity("Master", "Slave1");
setMasterSlaveActivity("Master", "Slave2");
setMasterSlaveActivity("Master", "Slave3");

//Master settings
set Master.onlySlaveInfo=false;
set Master.printSDO=false;
set Master.printPDOmap=false;
set Master.ethPort="eth4";

##### Platform Control Part #####
import("platform");

loadComponent("Platform", "Platform");
setActivity("Platform",0,10,ORO_SCHED_RT);

connectPeers("Platform", "Slave1");

```

```

connectPeers( "Platform" , "Slave2" );
connectPeers( "Platform" , "Slave3" );

var ConnPolicy cp_1

cp_1.type = DATA
cp_1.size = 1
cp_1.lock_policy = LOCKED

connect( "Platform.MasterRunning" , "Master.Running" , cp_1 )
connect( "Platform.sync" , "Master.sync" , cp_1 )

connect( "Platform.targetPDO1" , "Slave1.targetPDO" , cp_1 )
connect( "Platform.targetPDO2" , "Slave2.targetPDO" , cp_1 )
connect( "Platform.targetPDO3" , "Slave3.targetPDO" , cp_1 )

connect( "Platform.actualPDO1" , "Slave1.actualPDO" , cp_1 )
connect( "Platform.actualPDO2" , "Slave2.actualPDO" , cp_1 )
connect( "Platform.actualPDO3" , "Slave3.actualPDO" , cp_1 )

Platform.activateAutoLearning( false , 0.1 );
Platform.configure();

/*basicConfiguration(A,B,C,D,E)*/
//Where: A (unsigned int) is the controlMode. To activate the speed controller
//set controlMode to 1, while to activate the adaptative controller set it to 3.
//To avoid using closed loop set to 0. When using Joystick set it to 0.
//The use of controlMode=2 is deprecated since it uses the "old" adaptative
//controller without the platform dynamic model.
//B (bool) is fixedReferenceSystem option. [true ->fixed reference]
//C (double) is the motorSpeedLimit [m/s]
//D (double) is the platformSpeedLimit [m/s]
//E (string) is the controlInput that can be "Generator" or "Joystick"
Platform.basicConfiguration(0,true,0.8,0.8,"Joystick");

/*activateSecurityLimits(A,B,C,D,E,F)*/
//Where: A (double) is the maximum motor speed permitted expressed in [m/s]
//B (bool) activate or deactivate the operation-area limiting
//C,D,E,F are the coordinates of the square's sides expressed as:
//Xpositive ,Xnegative , Ypositive , Ynegative
Platform.activateSecurityLimits( false ,2.09 , -1,1 , -1.8);

/*activateObstacleAvoiding(A, B, C, D, E)*/
//Where: A (bool) activates the obstacle avoiding function.
//B and C (double) are the obstacle's center coordinates [m] along X and Y axes
//D (double) in the obstacle's radius in meters
//E (double) is the coefficient that regulate the tanfencial speed with respect

```

```

//the radius
Platform.activateObstacleAvoiding(false,1,-0.60,0.05,0.3);

##### Reference Generation Part #####
import("joystick");
loadComponent("Joystick","Joystick");
connectPeers("Platform","Joystick");
connect("Platform.trajectoryTarget","Joystick.targetsPort",cp_1)
connect("Platform.refSystem","Joystick.refSystem",cp_1)
connect("Platform.resetRefSystem","Joystick.resetRefSystem",cp_1)

Joystick.configure();

/*Coefficients used to map joystick values to the values sent to the platform*/
Joystick.SpeedConstant=0.0018;
Joystick.TurningConstant=0.0018;

Master.configure();

Master.start();

Platform.start();

##### Reporter Part #####
loadComponent("reporter","OCL::FileReporting");
setActivity("reporter",0.01,HighestPriority,ORO_SCHED_RT);

connectPeers("reporter","Joystick");
connectPeers("reporter","Platform");
connectPeers("reporter","Slave1");
connectPeers("reporter","Slave2");
connectPeers("reporter","Slave3");

reporter.reportPort("Joystick","targetsPort");
reporter.reportPort("Slave1","actualPDO");
reporter.reportPort("Slave2","actualPDO");
reporter.reportPort("Slave3","actualPDO");

reporter.reportPort("Platform","targetPDO1");
reporter.reportPort("Platform","targetPDO2");
reporter.reportPort("Platform","targetPDO3");

reporter.reportData("Platform","X");
reporter.reportData("Platform","Y");
reporter.reportData("Platform","Phi");
reporter.reportData("Platform","speedX");
reporter.reportData("Platform","speedY");

```

```

reporter.reportData("Platform","speedPhi");

//(optionally, overwrite the default report file name);
reporter.ReportFile = "reporterData.dat";

reporter.configure();
reporter.start();

```

Using the Generator

While using the Joystick no more files are required, if the user desires to use the generator to track a manually defined trajectory, the file pathPoints.dat has to be edited and placed in the same directory of the .ops. The points have to be expressed in this way (*absolute time, position along X axes in meters, position along Y axis in meters, position along θ axis in radians*).

To obtain a square trajectory with a 2 meters side, in 20 seconds the file pathPoints.dat would be:

```

(0,0,0,0)
(5,2,0,0)
(10,2,2,0)
(15,0,2,0)
(20,0,0,0)

```

While the configuration file would be:

Control_by_Generator.ops

```

##### EtherCAT Master Part #####
import("soem_SGDV");
import("soem_master");

//Load the components we are going to use
loadComponent("Slave1", "soem_master::soem_SGDV");
loadComponent("Slave2", "soem_master::soem_SGDV");
loadComponent("Slave3", "soem_master::soem_SGDV");
loadComponent("Master", "soem_master::SoemMasterComponent");

//To use DC clocks the period has to be 0 to let internal functions ensure
//synchronism. If you don't desire to use DCclock set the period in seconds.
setActivity("Master",0,10,ORO_SCHED_RT);

//If in the previous line you decided to use DC clocks you need to let the Master
//know the sync0 period you are going to set in your slaves.

```

```

set Master.cycleTime=250000; //The period has to be set in ns[0 to not use DC].

//This part is important for "real-virtual" slave matching
connectPeers( "Master", "Slave1" );
connectPeers( "Master", "Slave2" );
connectPeers( "Master", "Slave3" );

//Slaves are runned using MasterSlaveActivity
setMasterSlaveActivity( "Master", "Slave1" );
setMasterSlaveActivity( "Master", "Slave2" );
setMasterSlaveActivity( "Master", "Slave3" );

//Master settings
set Master.onlySlaveInfo=false;
set Master.printSDO=false;
set Master.printPDOmap=false;
set Master.ethPort="eth4";

##### Platform Control Part #####

import( "platform" );
loadComponent( "Platform", "Platform" );

setActivity( "Platform", 0, 10, ORO_SCHED_RT );

connectPeers( "Platform", "Slave1" );
connectPeers( "Platform", "Slave2" );
connectPeers( "Platform", "Slave3" );

var ConnPolicy cp_1
cp_1.type = DATA
cp_1.size = 1
cp_1.lock_policy = LOCKED

connect( "Platform.MasterRunning", "Master.Running", cp_1 )
connect( "Platform.sync", "Master.sync", cp_1 )

connect( "Platform.targetPDO1", "Slave1.targetPDO", cp_1 )
connect( "Platform.targetPDO2", "Slave2.targetPDO", cp_1 )
connect( "Platform.targetPDO3", "Slave3.targetPDO", cp_1 )

connect( "Platform.actualPDO1", "Slave1.actualPDO", cp_1 )
connect( "Platform.actualPDO2", "Slave2.actualPDO", cp_1 )
connect( "Platform.actualPDO3", "Slave3.actualPDO", cp_1 )

Platform.configure();

```

```

Platform . basicConfiguration ( 3 , true , 1.2 , 1.5 , " Generator " ) ;

Platform . activateSecurityLimits ( false , 2.09 , -1 , 1 , -1.8 ) ;

Platform . activateObstacleAvoiding ( false , 1 , -0.60 , 0.05 , 0.3 ) ;
//Parameter for the closed loop speed control
set Platform . K = 10 ;
//##### Reference Generation Part #####
import ( " generator " ) ;
loadComponent ( " Generator " , " Generator " ) ;

setActivity ( " Generator " , 0 , 10 , ORO_SCHED_RT ) ;

connectPeers ( " Platform " , " Generator " ) ;
//Possible Operation_mode: " ManualTrajectory " , " Circle " , " Ellipse " , " Spiral " ,
//" HolonomicTrajectory " ;
set Generator . Operation_mode = " Circle " ;
set Generator . Interpolation_mode = 3 ;

connect ( " Platform . trajectoryTarget " , " Generator . targetsPort " , cp_1 )
connect ( " Platform . refSystem " , " Generator . refSystem " , cp_1 )
connect ( " Platform . syncGenerator " , " Generator . syncToPlatform " , cp_1 )

Generator . configure ( ) ;
set Generator . fixedReferenceSystem = 1 ;

Master . configure ( ) ;
Master . start ( ) ;
Platform . start ( ) ;

```

About using Kst

As already explained, the Reporter (see chapter 6.2.3) is a component that writes desired data in a file, which can be read afterwards (off-line) or at runtime (on-line) with eg. Kst [19]. In our application it could be interesting to see the speeds and the torque values on-line therefore we have used KST to read from the file where the reporter writes. This file is just a table of the data and the Reporter could be set to report the headers too. After having set this option ⁴ you can select the right data column using its name as a reference.

Setting KST2 is very simple as the wizard helps us to select the file to read from⁵ and which file column to use. To make the various graphs we need to use the name variable that is the header

⁴enabled by default

⁵In our case *reporterData.dat*.

of the correspondent data column. To read data, we have to set KST to read from line 2 because the first line is, as explained, occupied by headers.

To start the application

As explained the user has only to edit the .ops to set the desired parameters and deploy the components in the correct way. Using the first provided .ops, the command that has to be written in the console⁶ is:

```
| $ deployer-gnulinux -s Control_by_Joystick.ops
```

⁶The user has to be in the folder where the .ops files and eventually the pathPoints.dat are.

Appendix C

TaskContext Example

As already explained Orocos provides a set of basic files to implement our TaskContext (see section 6.2.2). Inside this packet, the files we need to start editing are mainly two *myTask-component.hpp* and *myTask-component.cpp* while the others are used to add functionalities.

Defining the whole component in the .cpp file, a scheme, that contains just something more than the automatically provided scheme, would be:

myTask-component.cpp

```
#include <rtt/TaskContext.hpp>
#include <rtt/ComponentDeployment.hpp>
#include <rtt/Port.hpp>
#include <rtt/Attribute.hpp>
#include <rtt/Property.hpp>
#include <rtt/Operation.hpp>
/**
 * Note: we are defining a component as a class in a .cpp file
 * not in a header file!
 */
Class MyComponent
 : public RTT::TaskContext
{
Public:
  MyComponent(string name)
  : RTT::TaskContext(name)
  {
    /**Ports to communicate with the component or to wake up its thread*/
    // An 'EventPort' is an InputPort which can wakes up our task
    this->ports()->addEventPort( "evPort", evPort ).doc( "Input Port that raises an
      event when new data arrive." );
```

```

// These ports do not wake up our task
this->ports()->addPort( "inPort", inPort ).doc( "Input Port that does *not*
    raise an event." );
this->ports()->addPort( "outPort", outPort ).doc( "Output Port, here write our
    data to." );

/**To present variables in the component's interface*/
this->addAttribute( "myAttribute", myAttribute );
this->addConstant( " myConstant ", myConstant );
this->addProperty( "myProperty", myProperty ).doc("myProperty Description");

/**To present in the component's interface a non standard function*/
addOperation("myFunction", &MyComponent:: myFunction, this)
    .doc("Set parameter X").arg("value", "The argument of this method.");
}

bool configureHook() {
    // Further setup which could not be done in the constructor
    //Return false to abort configuration}

bool startHook() {
    // Application's start up code
    //Return false to abort start up }

void updateHook() {
    // Function called by the Execution Engine
    // algorithm goes in here}

void stopHook() {
    // Function called when a task is stopped
    // Stop code after last updateHook() goes in here}

void cleanupHook() {
    //Function called when a task is being deconfigured
    // Configuration cleanup code goes in here}

/**Optional code to extend the task*/
// Input port: We'll let this one wake up our thread
InputPort<double> evPort;

// Input port: We will poll this one
InputPort<double> inPort;

// Output ports are always 'send and forget'
OutputPort<double> outPort;

//Task's variables that can be presented in the interface

```

```
Double myAttribute , myConstant , myProperty ;

//Task's function that can be presented in the interface
void myFunction (double x) { // function's code };

/**Make MyComponent dynamically loadable*/
ORO_CREATE_COMPONENT(MyComponent)
```

Appendix D

CD contents

In the attached CD you can found:

- A copy of the thesis.
- The developed software with the “Orocos EtherCAT communication components” in both versions, with and without ports.
- A .pdf version of the file generated by the Master when choosing the option printSDO. This file reports the Object dictionary of our slaves and other useful informations such as the slaves’ delay and their PDOmapping.
- Some photos of the Barcelona Mobile Manipulator (BMM).
- Some videos showing the platform running controlled by the Trajectory Generator or by the joystick. Other videos showing the speed controller working and others functionalities such as “Obstacle Avoiding” and “Operation Area Limiting”.

Bibliography

- [1] J.A. Battle and A. Barjau. “Holonomy in mobile robots”. In: *Robotics and Autonomous Systems* (2009) (cit. on p. 64).
- [2] Beckhoff Infosys. URL: <http://infosys.beckhoff.com> (cit. on p. 98).
- [3] Beckhoff. *Hardware Data Sheet ET1100*. 2010. URL: http://www.beckhoff.com/english.asp?download/ethercat_development_products.htm (cit. on p. 102).
- [4] Beckhoff. *Slave Implementation Guide ETG.2200*. 2012. URL: http://www.ethercat.org/pdf/english/ETG2200_V2i0i0_SlaveImplementationGuide.pdf (cit. on pp. 92, 93).
- [5] Luigi Biagiotti and Paolo Melchiorri. *Trajectory Planning for Automatic Machines and Robots*. Springer, 2008 (cit. on p. 60).
- [6] H. Boterenbrood. *CANopen high-level protocol for CAN-bus*. 2000 (cit. on p. 99).
- [7] Herman Bruyninckx. *Control of a mobile Platform*. URL: <http://www.orocos.org/forum/orocos/orocos-users/control-mobile-platform> (cit. on pp. 19, 85).
- [8] YASKAWA ELECTRIC CORPORATION. *AC Servo Drives Series Σ -V USER'S MANUAL EtherCAT (CoE) Network Module Model: SGDV-OCA01A*. SIEP C720829 04A. 2009. URL: [http://www.yaskawa.com/site/dmservo.nsf/link2/SCAG-7TTSVW/\\$file/SIEPC72082904.pdf](http://www.yaskawa.com/site/dmservo.nsf/link2/SCAG-7TTSVW/$file/SIEPC72082904.pdf) (cit. on pp. 24, 37).
- [9] Daniel Clos Costa and Jordi Martinez Miralles. “PLATAFORMA MÒBIL AMB RODES ESFÈRIQUES PER AL ROBOT LIGHTWEIGHT ROBOT 4 DE KUKA ROBOTER”. 2008 (cit. on p. 63).
- [10] Copley Controls. *EtherCAT network synchronization*. 2012. URL: www.copleycontrols.com/Motion/pdf/ecat-sync.pdf (cit. on p. 99).
- [11] Jean-Jacques E. Slotine and Li Weiping. *Applied Nonlinear Control*. Prentice Hall, 1991 (cit. on p. 65).
- [12] Jean-Jacques E. Slotine and Li Weiping. “Adaptive Manipulator Control: A Case Study”. In: *IEEE TRANSACTIONS ON AUTOMATIC CONTROL*, 33.11 (1988), pp. 995–1003 (cit. on p. 68).

- [13] *Eigen*. URL: http://eigen.tuxfamily.org/index.php?title=Main_Page (cit. on p. 62).
- [14] *EtherCAT Technology Group*. URL: <http://www.ethercat.org> (cit. on p. 89).
- [15] *Ethercat driver for OROCOS*. URL: lists.mech.kuleuven.be/pipermail/orocos-users/2011-April/003580.html (cit. on p. 30).
- [16] Mateo Garrió Grau. “Vehicle AGV omnidireccional de rodes no convencionals. Disseny del grup motriu”. Master thesis (cit. on p. 26).
- [17] EtherCAT Technology Group. *EtherCAT Technology Group* (cit. on p. 100).
- [18] Huang Hsu-Chih and Tsai. Ching-Chih. *Proc. 17th Word Congress (DISC 2008) The International Federation of Automatic Control*. 2008 (cit. on pp. 68, 70).
- [19] *KST*. URL: <http://kst-plot.kde.org/screenshots/dialogs/> (cit. on pp. 45, 112).
- [20] Arthur Ketels. *Simple Open EtherCAT master*. URL: <http://soem.berlios.de> (cit. on p. 29).
- [21] Arthur Ketels. *Using DC clock*. URL: lists.berlios.de/pipermail/soem-user/2012-May/000109.html (cit. on pp. 31, 35–37).
- [22] *Kuka YouBot*. URL: <http://youbot-store.com/category/53-youbots.aspx> (cit. on p. 13).
- [23] Robert L. Williams and Jianhua Wu. “Dynamic Obstacle Avoidance for an Omnidirectional Mobile Robot”. In: *Journal of Robotics* (2010) (cit. on pp. 73, 74).
- [24] Paolo Melchiorri. *Traiettorie per azionamenti elettrici*. Esculapio, 2000 (cit. on p. 60).
- [25] *Realtime safe matrix library*. URL: <http://www.orocos.org/forum/orocos/orocos-users/realtime-safe-matrix-library> (cit. on p. 62).
- [26] Alireza Sahraei et al. “Proc. 10th Congress of the Italian Association for Artificial Intelligence”. In: *Real-Time Trajectory Generation for Mobile Robots*. Vol. 4733. Springer, 2007, pp. 459–470 (cit. on pp. 72, 88).
- [27] *Setting up RTNet for SOEM on Xenomai?* URL: <http://www.orocos.org/forum/orocos/orocos-users/setting-rtnet-soem-xenomai> (cit. on p. 30).
- [28] Peter Soetens. *The Orococos Component Builder’s Manual : Open RObot COntrol Software : 2.5.0*. 2011. URL: <http://www.orocos.org/stable/documentation/rtt/v2.x/doc-xml/orocos-components-manual.html> (cit. on pp. 41, 43, 44, 46).
- [29] Peter Soetens and Herman Bruyninckx. *How to synchronise tasks?* URL: <http://www.orocos.org/forum/orocos/orocos-users/how-synchronise-tasks> (cit. on pp. 45, 46).
- [30] *Wireshark*. URL: <http://www.wireshark.org/> (cit. on p. 87).
- [31] *libusb*. URL: <http://www.libusb.org/> (cit. on p. 58).