

16IC104 Advanced Parameter Measurement of Energy Storage Systems for Smart Grids application

Daniele Gallo⁸⁵, Carmine Landi⁸⁵, Mario Luiso⁸⁵

The smart grid approach is envisioned to take advantage of all available modern technologies in transforming the current power system to provide benefits to all stakeholders first of all in the fields of efficient energy utilization and of wide integration of renewable sources. Energy storage systems, especially those based on batteries, could help to solve some issues that stem from the use of renewable energy, in terms of stabilizing the intermittent energy production, power quality and power peak mitigation. With the integration of energy storage systems into the smart grids, their accurate modelling becomes a necessity, in order to gain a robust real-time control on the network. In this framework, this paper proposes a procedure for a better identification of the battery model parameters in order to best fit experimental data. The proposed method is based on a hybrid optimization technique, which makes a combined use of a stochastic and a deterministic algorithm, and it has a low computational burden, therefore it can be repeated over the time in order to account parameter variations due to the battery age and usage

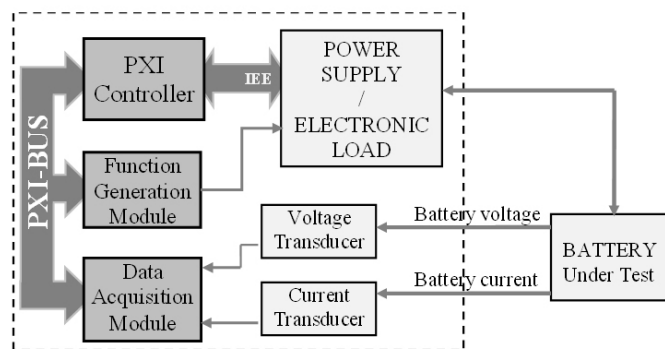

Block scheme of the Measurement System.

16IC138 Voltage Source Inverters: an Easy Approach for Fast Fault Detection

A. O. Di Tommaso¹⁰⁶, F. Genduso¹⁰⁶, R. Miceli¹⁰⁶, C. Spataro¹⁰⁶

Fault-tolerant converters have been widely investigated for years and nowadays an extensive technical literature on this field exists. This paper presents a novel fault detection algorithm based on a simple geometrical approach. In the algorithm analysis both the case of faults in single device and the loss of an entire inverter leg have been considered. The proposed methodology is characterized by simplicity, low computational and implementation effort with a consequent fast execution and easy control integration. The suggested algorithm is verified by means of experimental tests and reveals a valid and suitable alternative to the existing state of the art in the field of inverter fault detection.