

12PQ071 Virtual Instrument for Power Quality Research

Vladimir Dimcev¹⁰², Zivko Kokolanski¹⁰², Dimitar Taskovski¹⁰²

In the paper a virtual instrument for power quality measurement and research is proposed. The instrument is divided in several modules which provide generation, measurement and recording of the typical power quality (PQ) disturbances such as: harmonics, voltage dips, interruptions, flicker, unbalance etc. The virtual instrument allows setting different measurement parameters which expands its capabilities for research work. To perform real-time monitoring a prototyped signal conditioning circuit has been developed.

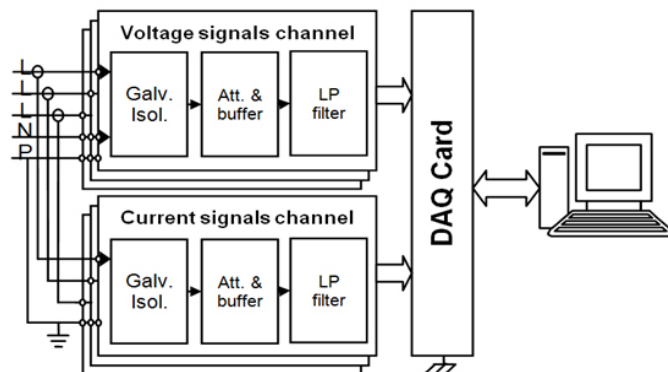
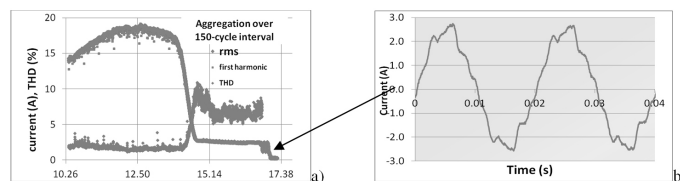

Figure captions in Times New Roman 10pt centered

12PQ134 Characterised measuring system for PQ measurements on the MV grid

G. Crotti⁹⁶, D. Giordano⁹⁶

The features of a PQ measurement system which includes both voltage and current transducers and a self-developed measuring instrument are described. The system is intended for measurements at medium voltage level. A Rogowski coil and a voltage divider are the used transducers, whereas the measuring system is based on a Reconfigurable I/O-FPGA system with embedded software. Attention is focused on the characterisation of the current sensor, which is carried out taking into account the expected on-site measurement conditions and allows significant reduction of the measurement uncertainty. The use of the measurement system in a private substation that connect an industrial load and two PV generation plants to the public MV voltage network is presented.



a) measured rms current and THD over 8 hours in a sunny autumn day;

b) current waveform