

# Domestic oven heated by a concentrating solar collector

Joaquim Lloveras

*Dpt. of Engineering Projects, Eng. School of Barcelona, Tech. University of Catalonia (UPC)  
+34 934016642. E-mail: j.lloveras@upc.edu*

## ABSTRACT

A project to power a domestic oven by solar energy was developed. The focal axis of a cylindrical parabolic reflector usually reaches temperatures of up to 250°C. A heat transfer fluid carries this heat to the heat exchanger in the oven. Current domestic ovens are generally electric and can reach 250°C with a power of 2-3 kW.

The installation is composed of pumps, valves, thermally insulated pipes, exchanger, etc. These elements transfer the heat collected by the solar collector to the oven in the house. If the installation has an accumulator tank with thermal insulation, the high temperature liquid makes it possible to use the oven at any time.

Unlike current domestic solar ovens, this technology can reach the same temperature and power as an electric oven, and be used indoors at any time.

Additionally, this system could be used for sanitary hot water purposes and radiating floors. In these cases, the high temperature is degraded mixing with cold water.

*Keywords: Project, cylindrical parabolic collector, solar, oven, installation*

## 1. Introduction

The project challenge was to design a system powered by solar energy and with similar functions to conventional electric ovens. Solar energy was chosen as the energy source to avoid using fuel, such as gas, electricity or wood, to cook food. Unfortunately, the current technology has several limitations.

Several types of solar ovens or cookers [1] that use solar radiation instead of fuel are currently available. One of the most common is a thermally insulated box fitted with a transparent glass or plastic top which absorbs direct solar radiation or mirrors or mirror coated material which reflects the light (figure 1). This device reaches sufficiently high temperature (up to 150-165°C) to cook by taking advantage of the greenhouse effect. It can cook almost the same foods as conventional ovens; however, the process can



Figure 1. Solar oven model. Solar oven Portugal 2007. Parabolic solar Scheffler cooker [1]

take hours and it is necessary to turn the oven to face the sun and adjust its position every hour or so. Moreover, this outdoor cooking method requires appropriate weather conditions, e.g. absence of clouds, strong winds and shadows, and in some latitudes, the box must be used in the central hours of the day (two hours before and after the solar noon). A final detail is that some thick foods may need chopping into small chunks before cooking.

There are other systems, which use parabolic reflectors to concentrate the solar radiation in the pot (figure 1) that cook faster than solar boxes. Nevertheless, they require more precise sun tracking.

A conventional domestic oven usually reaches 250°C with an electric power of about 2-3kW for food cooking. Compared with the solar oven, it is faster and more precise. Figure 2 shows the inside of a domestic oven, with a fan on the rear wall to homogenize the air temperature.



Figure 2. Indoor domestic oven with a fan [2]

In order to provide the proposed design with the characteristics of a conventional domestic oven, it was decided to use a concentrating solar collector, which can provide higher temperatures than a flat-plate collector and almost the same amount of collected energy for the same surface. Cylindrical parabolic solar collectors track the sun by means of a rotation axis and concentrate the solar radiation onto a linear receiver at the focal axis.

The project consisted in the design of a system fitted with a concentrating solar collector, which obtains enough energy to run a domestic oven in the house. Another aim was to find potential heat transfer fluids and suitable construction materials. This project was developed by a group of students [3] taking an Engineering Project course [4] within the Materials Engineering degree program taught at the Engineering School of Barcelona (ETSEIB) [5] (Technical University of Catalonia (UPC)) [6].

## 2. Project development

The cylindrical parabolic collector (1) of Figure 3 concentrates the sun's rays onto a linear receiver at the focal axis (19). The receiver is usually a tube carrying a fluid that absorbs the heat for later use. A solar concentration factor of about 30 [7] enables the temperature to increase up to 250°C. The average amount of energy collected by a 3m-long cylindrical parabolic module with a 1.14m opening is approximately 1.5-2kW in the central hours of the day (in the middle latitudes).

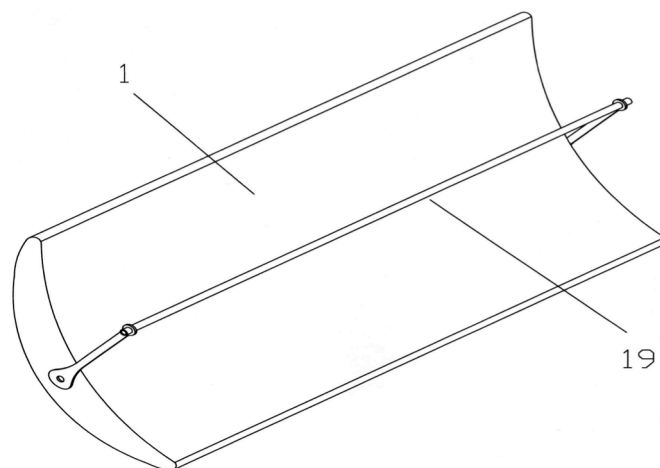

Figure 3. Cylindrical parabolic solar collector [3]

These features coincide with the basic characteristics of

conventional domestic ovens. To obtain more power or feed other appliances, several cylindrical parabolic mirrors must be connected in series.

A very simple version of this system is to make the fluid heated at the focal axis (19) of the cylindrical parabolic solar collector go directly to an exchanger coil in the oven. This installation needs a pump, valves, an expansion vessel, thermally insulated pipes, control system, etc.

A more flexible installation includes a high temperature heat storage tank. Figure 4 is a diagram of this system formed by a cylindrical-parabolic collector (1) and a tube that carries the heat transfer fluid to an exchanger coil (10) in a storage tank (9). From there, the fluid passes through the exchanger coil (3) in the oven (2), which transfers heat by means of an indoor fan (4). In this case, the accumulator tank enables use of the oven at any time.

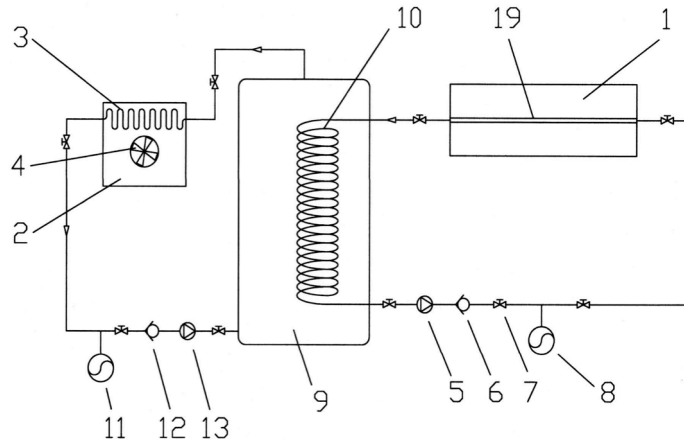

Figure 4. System formed by a cylindrical parabolic collector, a storage tank and an oven [3]

A more complete installation is illustrated in figure 5. In this artistic representation, we can see two cylindrical parabolic collectors on the roof of a house that track the sun. Liquid heated at a high temperature is stored in an accumulator tank from which the oven can be directly powered. Another accumulator tank (not drawn) can feed several appliances at a low temperature by mixing with cold water for sanitary hot water purposes like showers. This installation can also feed a radiating floor.



Figure 5. House with cylindrical parabolic collectors, storage tank, oven and shower [3]

### 3. Discussion and Conclusions

Safe cooking requires a minimum of 65-75°C of food internal temperature [8], but if this is the maximum temperature an oven can reach, a long time is required for cooking thick foods. A conventional electric oven cooking at 250°C is faster and the food is crusty and tasteful. A cylindrical parabolic solar collector is able to reach 250°C.

A conventional electric oven cooking at 250°C is faster and the food is crusty and tasteful. A cylindrical parabolic solar collector is able to reach 250°C.



In this system, the collector can be placed far from the oven, thus allowing indoor cooking. A conventional oven (2) can be modified to fit an exchanger coil (3). This oven uses solar energy whenever possible and electricity in the absence of solar radiation, leading to a significant CO<sub>2</sub> emission reduction.

The thermal storage tank (9) allows the oven to be used at any time. When the oven is not being used, the collector can be placed out of the Sun's path.

This system must be very secure to prevent injury due to high temperature of the fluid. With adequate temperature control, this system can also power the household heating system, provide hot water for bathing, etc.

The project met the required specifications, and a Spanish patent application [9] was presented. A cost estimate and (a long) period of return on investment (ROI) for a particular assumption were calculated. Indeed, this installation is expensive compared with current inexpensive solar ovens, but costs will be lower in the future. This new installation of solar technology has similar features to conventional electric ovens but with no CO<sub>2</sub> production. It is a flexible installation, so uses include not only cooking but also several sanitary purposes. Last but not least, the system is pro sustainability.

#### 4. References

- [1] Solar cooker [http://en.wikipedia.org/wiki/Solar\\_cooker](http://en.wikipedia.org/wiki/Solar_cooker) (Accessed 05/22/2014)
- [2] <http://www.electrolux.es/Productos/Cocina/Hornos/> (Accessed 06/02/2014)
- [3] G2: Noemí Finez, Borja González, Carles Pons, Tania Sola, Naiara Vázquez (2012). "El forn domèstic que aprofita la energia solar" (The household oven that uses solar energy). Final project of Engineering Project Course. Second semester of academic year 2011-12. Degree in Materials Engineering. Engineering School of Barcelona (ETSEIB). Technical University of Catalonia (UPC).
- [4] Engineering Project course of Materials Engineering degree, [http://guiadocent.etseib.upc.edu/guiadocent/fitxes/EM/ESP/24900\\_ESP.html](http://guiadocent.etseib.upc.edu/guiadocent/fitxes/EM/ESP/24900_ESP.html) (Accessed 05/30/2014)
- [5] Engineering School of Barcelona (ETSEIB) <http://www.etseib.upc.edu/en> (Accessed 05/30/2014)
- [6] Technical University of Catalonia (UPC) [http://www.upc.edu/?set\\_language=en](http://www.upc.edu/?set_language=en) (Accessed 05/28/2014)
- [7] A2 Smirro\_300 Datenblatt\_ES-EN. <http://smirro.de/smirro/index.php/es/downloads-3>, accessed (01, 09, 2014).
- [8] Safe Minimum Cooking Temperatures <http://www.foodsafety.gov/keep/charts/mintemp.html> (Accessed 06/02/2014)
- [9] Joaquim Lloveras Macià; Finez Acero, Noemí; González Jiménez, Borja; Pons Garulo, Carles; Solá Saiz, Tania; Vázquez Fernández, Naiara Iliá. (2012) "Sistemas con colector solar cilíndrico parabólico para viviendas". Patente ES2430791.

#### Acknowledgements

The author would like to thank the students of group G1 of the Engineering Project course within the Materials Engineering degree programme, 2011-12 academic year, who conducted the work described in the paper "El forn domèstic que aprofita la energia solar" (The household oven that uses solar energy): Finez Acero, Noemí; González Jiménez, Borja; Pons Garulo, Carles; Solá Saiz, Tania; Vázquez Fernández, Naiara Iliá, from the Engineering School of Barcelona (ETSEIB) (Technical University of Catalonia (UPC)).