

Power Supply Control of the OBSEA Seafloor Observatory

Xavier Palou, Marc Nogueras, Antoni Mànuel

SARTI (Remote Acquisition and Data Processing Systems), UPC (Technical University of Catalonia)

Rambla de l'Exposició, 24, Ed. VG5

08800 Vilanova i la Geltrú (Barcelona) SPAIN.

Tel.:(+34) 938 967 200 eMail: marc.nogueras@upc.edu

Abstract - The aim of this paper is to present the design and construction process of the power supply needed for a remote data acquisition system. It is based on twelve AC to DC switching converters in a serial connection and a logic programmable controller (PLC). The energy is transmitted to the acquisition system, which is located several kilometers away, by means of a cable. The supply system has been designed with a higher capacity than the current requirements of the subsea station and the controller decides constantly the best configuration required at each moment.

Keywords

OBSEA, Power Supply, PLC, Omron CPL1.

I. 1. INTRODUCTION

In such a big project as OBSEA (Expandable Submarine Observatory) a large variety of problems turns up during the designing process. One of them is the necessity of feeding equipment that works continuously and is installed some kilometers away from the control center. Therefore we have to design a system capable of detect the observatory consumption variations and respond automatically without the action of an operator. Furthermore, the chance of adding complementary sensors to the observatory forces to include a wide enough consumption margin to meet higher energy demands. Finally, to enable the monitoring of the process we need periodic reports and incident signaling.

To catch up with all this requirements, the whole system revolves around the programmable logic controller which analyzes the observatory consumptions using the data obtained by current and voltage sensors. Consequently, it activates the necessary number of converter switches. In usual conditions, the acquisition system works with only four converter switches but up to twelve units are installed to respond to possible consumption peaks or failures.

II. 2. SYSTEM DESCRIPTION

The main elements of the system are the Omron CP1L M30DR-A programmable logic controller (18 digital inputs and 12 digital outputs), the twelve converter switches that supply 27VDC each and the analog module CPM1A-MAD01 that deal with the data acquired by the sensors. All of them are fed directly from the electrical grid. The converter switches are serially connected so the system can provide a maximum voltage of $27 \times 12 =$

324VDC. In the fig 1 can be seen the connection diagram of the power supplies. They are activated and deactivated by means of the twelve CP1L digital outputs working as switches.

The use of the whole capacity depends on the instantaneous consumption of the subsea station. To control it, two sensors are installed in the power circuit. Firstly, a LEM current sensor is serially connected to the switching converters output and provides to the PLC an output voltage proportional to the consumed current. Secondly, a voltage divisor connected in parallel provides a voltage proportional to the total generated voltage. These two signals are read by the analog module CPM1A and converted into 8 bit words that will be send to the CP1L module through its expansion bus. Moreover, to complete the analysis of the system status, the output of each switching converter is individually connected to one of the CP1L digital inputs using a bank of optocouplers that isolates the CP1L logic circuit from the power circuit.

All the data that reach the CP1L is processed to found the best output configuration in real time. The programming language used is a ladder program written in the CP1L by means of CX-Programmer, software provided by the manufacturer. The program has different targets to achieve. First of all, it has to work out how many switching converter are necessary depending on the current consumption and the number of converter switches currently running. When the current consumption grows up over a top threshold and not all the converter switches are on, a new one is started. On the contrary, if the current consumption falls under the low threshold and more than the minimum converter switches are on, then one of them is turned off. As well, the data from the voltage divider and the CP1L inputs is used to detect failures in the converter switches so they could be reported to the control center using the RS-232 embedded serial port. In the same manner, the program sends a status message each time a converter switch changes its state. Finally, the program has a maintenance function that ensures that all the converter switches work the same. It keeps count of every converter switch work hours and periodically checks if the running converter switches are the more restful ones.

To keep the best security and order, all the elements are placed in a steel box with the most possible simplified external connections. The objective is not to open it again after the initial starting if it is not absolutely necessary.

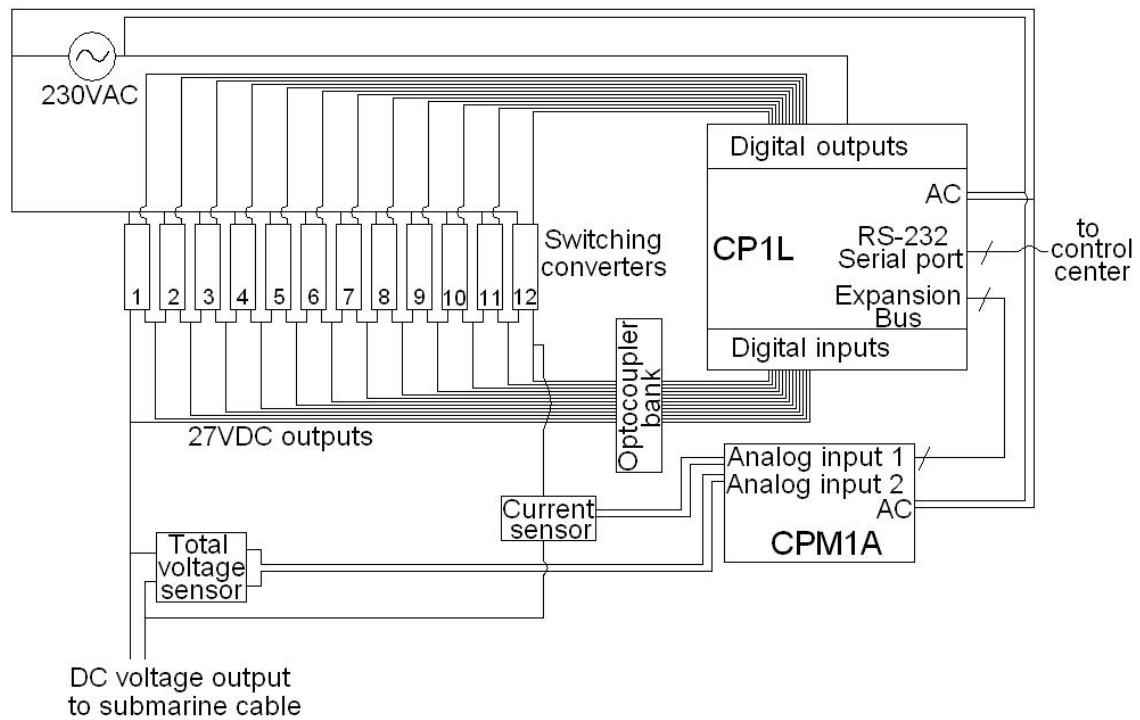

Fig.1 Schematic diagram of the power supply

III. 3. CONCLUSION

The outline of this design responds to some particular requirements of a determinate remote acquisition system. Specifically it gives a solution to the need of automation. Nevertheless, these features don't differ too much from the characteristics that any other scientific equipment could require, either it is remote or not. Thus, the design could be adapted for innumerable applications.

Besides, the used components are the ones which best fit in with the acquisition system needs, but in the catalogues are thousands of different components so we can change any feature easily.

REFERENCES

- [1] M. Nogueras, J. Santamaria, A. Mánuel, "Construction of the OBSEA Cabled Submarine Observatory" Instrumentation Viewpoint, Num.6, pp33-34, autumn 2007.
- [2] SARTI. <http://www.cdsarti.org>