

Audio equalizer features transimpedance Q-enhancement topology

Herminio Martínez, Encarna García, and Eva Vidal,
Technical University of Catalonia, Barcelona, Spain

In general, audio equalizers need second-order bandpass filters. Such cells require an easy and independent tuning of their parameters: the natural or central frequency, ω_0 ; the quality factor, Q; and the maximum bandpass gain, k. The use of cells with independent adjustments could require state-variable topologies. Unfortunately, this sort of structure usually needs at least three operational amplifiers. The basis for an alternative uses SAB (single-amplifier-biquadratic) filters. These cells allow obtaining second-order bandpass filters, but they have two main drawbacks: The quality factors that you can obtain with these cells have a practical maximum limit, and you cannot independently tune the three characteristic parameters.

This Design Idea instead uses the TQE (transimpedance-Q-enhancement) structure in an audio-equalizer

(Figure 1). This cell has two advantages when you use it in equalizer circuits: You can adjust the three characteristic parameters in an independent way, but it uses only two operational amplifiers per cell. Reference 1 presents the generic TQE topology. Figure 1 shows the configuration that implements a bandpass filter based on the generic structure. This structure, which processes current-input signals, shows low-impedance input without the resistor R_{IN} . Considering that R_1 and R_3 are equal in value and that all the capacitors are equal to C, the transimpedance, $Z(s)$, is:

$$Z(s) = \frac{V_{BP}(s)}{I_{IN}(s)} = \frac{R_1^2 C s}{R_1^2 C^2 s^2 + (2 - R_1/R_2) R_1 C s + 1}$$

However, by adding R_{IN} , the in-

DI Inside

66 AMI-to-NRZI-direct-conversion circuit tolerates unequalized pulse tails

70 Virtual RF generator measures load impedance and power

► What are your design problems and solutions? Publish them here and receive \$150! Send your Design Ideas to edndesignideas@reedbusiness.com.

put has high impedance, allowing the processing of voltage input signals because R_{IN} provides the required voltage-to-current conversion. In this way, the input-to-output transfer function, $H(s)$, is:

$$H(s) = \frac{V_{BP}(s)}{V_I(s)} = \frac{R_1}{R_{IN}} \frac{s/R_1 C}{s^2 + s(2 - R_1/R_2)/R_1 C + 1/R_1^2 C^2}$$

Thus, the circuit implements a second-order bandpass-transfer function; the following equations yield the central frequency, ω_0 , and the quality factor, Q:

$$\omega_0 = 1/R_1 C; Q = \frac{R_2}{2R_2 - R_1}$$

and the value of the gain, k, is:

$$k = \frac{R_1}{R_{IN}} Q = \frac{R_1}{R_{IN}} \left(\frac{R_2}{2R_2 - R_1} \right)$$

Thus, you can make the adjustments of ω_0 , Q, and k with R_1 , R_2 , and R_{IN} , respectively.

You can use the bandpass cell in Figure 1 in an audio equalizer. Figure 2 shows a possible implementation of a

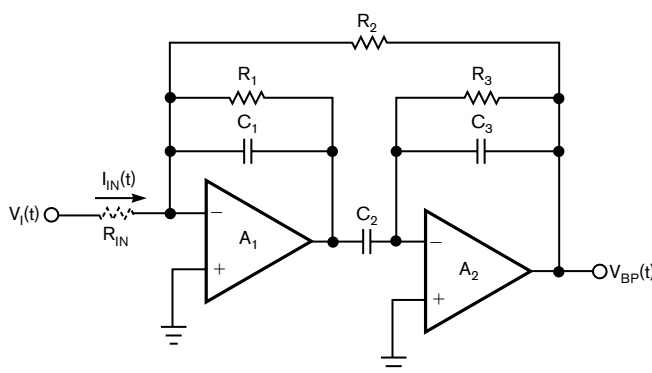

Figure 1 Adding R_{IN} to this bandpass filter based on a TQE structure causes the circuit to show high input impedance.

graphic equalizer. The basis for the circuit is a bank of bandpass TQE cells. Note that the cells are TQE with low-impedance input. Thus, the input network's R_{IN} converts $V_{IN}(t)$ and $V_{OUT}(t)$ to the corresponding input current, $I_{IN}(t)$. Adjusting potentiometer R_{IN} with its wiper to the far left ($X_1 \rightarrow 0$) accentuates the frequency band that the corresponding cell covers in the overall circuit output. On the other hand, positioning the wiper of R_{IN} to the far right ($X_1 \rightarrow 1$) causes a large amount of negative feedback to occur at this same frequency, thus causing attenuation in the forward-signal path. In each case, the remaining filters' TQE₁ receives percentages of both the input signal, $V_{IN}(t)$, and the output signal, $V_{OUT}(t)$, in ratios that their respective potentiometer settings determine.

You can derive the overall transfer function from **Figure 2**. The output voltage, $V_{OUT}(s)$, of the equalizer is:

$$V_{OUT}(s) = - \left\{ V_{IN}(s) + A \sum_{I=1}^N Z_1(s) \left[\frac{V_{IN}(s)}{X_1 R_{IN}} + \frac{V_{OUT}(s)}{(1-X_1)R_{IN}} \right] \right\}$$

where $Z_1(s)$ are the cells' transimpedances, and

$$A = \frac{R_B}{R_A}$$

If you define

$$H_1(s) = Z_1(s)/R_{IN}$$

then the transfer function of the equalizer becomes

$$\frac{V_{OUT}(s)}{V_{IN}(s)} = - \frac{1 + A \sum_{I=1}^N \frac{H_1(s)}{X_1}}{1 + A \sum_{I=1}^N \frac{H_1(s)}{1-X_1}}$$

Now, you can investigate the effect of various settings of the potentiometers. For example, in the case with all of the controls centered, X_1 equals 0.5 for each band. Then, $V_{OUT}(s)/V_{IN}(s) = -1$, as you would expect in a typical equalizer's response. Setting band $I=1$ to a value of X_1 and all other bands flat—that is, $X_1=0.5$ for $I=2, 3, \dots, n$), you obtain:

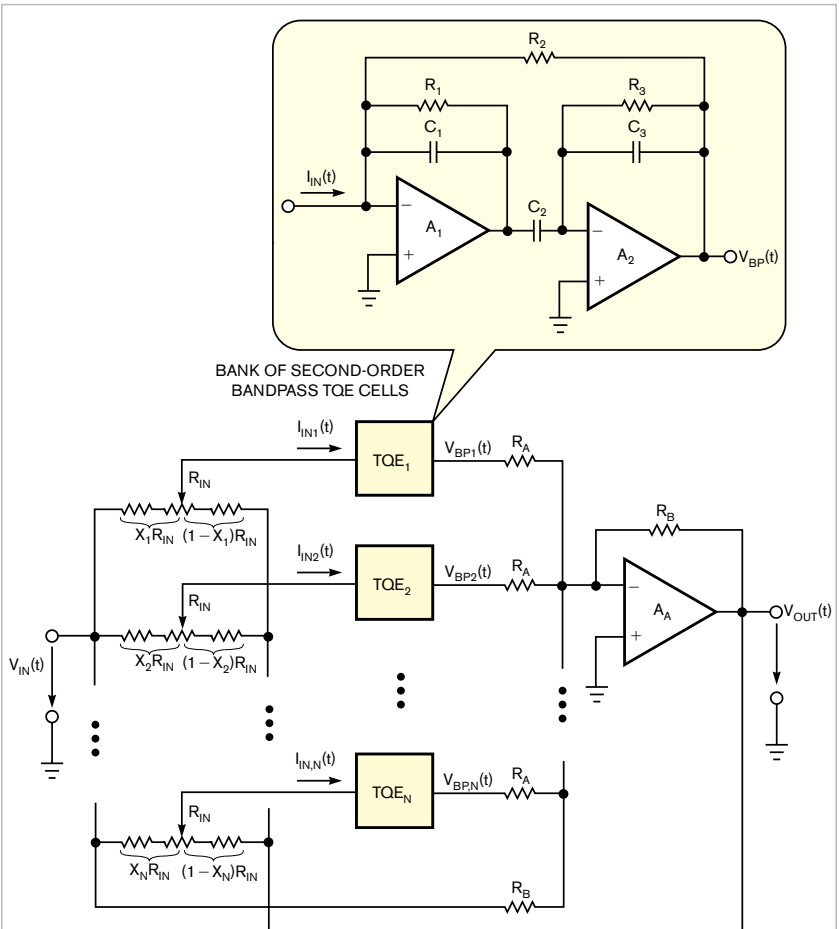

Figure 2 The TQE cells in this graphic equalizer have low-impedance inputs.

$$\frac{V_{OUT}(s)}{V_{IN}(s)} = \frac{s^2 + \left(\frac{\omega_{01}}{Q_1}\right) \left[1 + \frac{1}{1+2AM} \left(\frac{A}{X_1} - 2A \right) k \right] s + \omega_{01}^2}{s^2 + \left(\frac{\omega_{01}}{Q_1}\right) \left[1 + \frac{1}{1+2AM} \left(\frac{A}{1-X_1} - 2A \right) k \right] s + \omega_{01}^2}$$

which represents a bandpass filter with unity gain, or 0 dB, in the stopband and a gain of A_0 at resonance, and M is a constant representing the average value of the complete summation. M is approximately 1.3, or approximately 2.3 dB (**Reference 2**). Note that this gain can be higher—that is, boost—or lower than one. Considering as typical values $M=1.3$, $A=1$, and $k=1$, you can simplify the **equation** for passband gain A_0 , which is equal to the ratio of the s term coefficients, as:

$$A_0 = \frac{3.6 + \left(\frac{1-2X_1}{X_1} \right)}{3.6 + \left[\frac{1-2(1-X_1)}{1-X_1} \right]}$$

As an example, consider the case of an octave-band equalizer with 10 bands. In this case, the value of the quality factor for each band is about 1.42 (**Reference 3**), and the typical central frequencies of the 10 sections are 32 Hz to 16 kHz. Adjusting R_{IN} in the input of the cell TQE with its wiper to the left boosts the frequency band that the corresponding cell covers in the overall circuit output. For instance, if X_1 is 0.1, then A_0 is approximately 13 dB. On the other hand, positioning the wiper of R_{IN} to the right causes attenuation in the forward-signal path. So, if X_1 is 0.9, then A_0 is

approximately -13 dB. You must have a minimum input impedance in each cell for the input voltage, $V_{IN}(t)$, and the feedback voltage, $V_{OUT}(t)$. Thus, the inclusion of two resistors in series with each potentiometer R_{IN} in **Figure 2** guarantees this resistance. **EDN**

REFERENCES

Carlosena, Alfonso, and Eusebio

Cabral, "Novel Transimpedance Filter Topology for Instrumentation," *IEEE Transactions on Instrumentation and Measurement*, Volume 46, No. 4, pg 862, August 1997, http://ieeexplore.ieee.org/xpl/freeabs_all.jsp?tp=&arnumber=650789&isnumber=14201.

Greiner, RA, and Michael Schoesow, "Design Aspects of Graphic

Equalizers," *Journal of the Audio Engineering Society*, Volume 31, No. 6, pg 394, June 1983, www.aes.org/e-lib/browse.cfm?elib=4574.

Bohn, Dennis A, "Constant-Q Graphic Equalizers," *Journal of the Audio Engineering Society*, Volume 34, No. 9, September 1986, www.rane.com/pdf/constanq.pdf.

AMI-to-NRZI-direct-conversion circuit tolerates unequalized pulse tails

Glen Chenier, TeeterTotterTreeStuff, Allen, TX

AMI (alternate-mark inversion) is a three-level—positive, zero, negative—copper-cable transmission code with the useful property of having no dc component for ease of ac coupling using capacitors or line-coupling transformers and a spectral peak at one-half the symbol rate. The zeros symbols transmit as 0V; the ones symbols transmit at half-unit intervals with alternating-line polarity to maintain the dc balance.

An interesting feature of the three-level AMI code is that you can easily translate it directly from and to the two-level NRZI (non-return-to-zero-inverted) code. The basis for NRZI is a transition, not a level; an NRZI edge in either the rising or the falling direction signifies a logic one. A lack of transition in a given symbol interval signifies a logic zero. Thus, the NRZI code is invertible without destroying the logic sense. Absolute level is meaningless. The only information content is the change or no change of level at the expected transition time. Likewise, the AMI code is invertible; you need not worry about the twisted-pair polarity. **Figure 1** shows the relationships between NRZ (non-return-to-zero), NRZI, and AMI codes.

The usual received-data-recovery method for AMI comprises a pair

of voltage-level slicers, or comparators, that combine the transmission-line-positive and -negative marking symbols into a two-level RZ code (**Figure 2a** through **d**). The symbols are then further changed into the standard NRZ-logic representation (not shown), typically with a D-type sampling flip-flop or similar circuitry.

One impediment to successful AMI transmission over distance is the "pulse-tail"-cable artifact. When you do not drive the cable to a positive- or a negative-marking pulse, such as in a zero following a one, the last transmitted marking pulse extends in time and slowly decays to zero. This effect becomes more pronounced as the cable gets longer, and, unless you eliminate it through the use of a frequency-equalization network that matches the cable-length and -attenuation characteristics, it will wreak havoc on the data-recovery slicers (**Figure 2e** and **f**).

You can easily convert two-level NRZI to three-level AMI through a straightforward algorithm that you can implement with a few gates and line drivers, a transformer, and a delay line if the system clock is unavailable. If no NRZI transition exists, transmit nothing for that symbol interval. For every rising NRZI edge, transmit a marking pulse, usually with a duration of one-half-symbol interval. For convenience, assign this pulse polarity as positive. For every falling NRZI edge, transmit a similar marking pulse of the opposite polarity to that of the rising edge. This step automatically creates the alternate marking polarities. Again for convenience, assign this pulse polarity as negative.

Recovering the NRZI directly from the AMI is likewise a straightforward algorithm (**Figure 3a** and **b**). If there is no received-voltage-threshold crossing of opposite polarity to that of the previous marking-threshold crossing, retain the last received-marking state at logic high or logic low. If the received-AMI voltage crosses a threshold at a polarity opposite to the current state

of the detector output, toggle the detector output to the state associated with that new polarity. Again, for convenience, if the AMI-pulse-threshold crossing is positive above the midlevel, or zero, toggle the detector output to a rising edge; if the AMI-pulse-threshold crossing is negative below the midlevel, or zero, toggle the detector output to a falling edge.

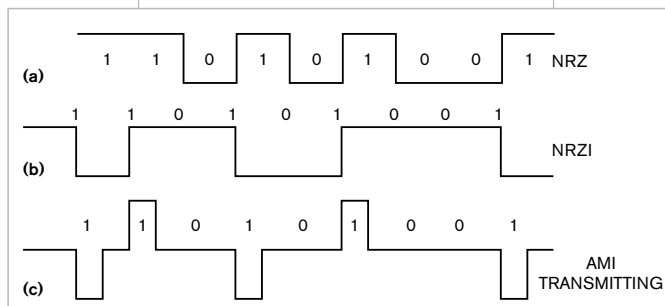

Figure 1 These waveforms illustrate an NRZ-to-NRZI-to-AMI conversion. Only when NRZ (a) is at logic one does NRZI (b) change at bit boundaries. AMI marks at the polarity of the NRZI transition (c).

From these algorithms, you can see that this receiving method directly translates the AMI code into the NRZI code. Also, by its requirement for alternate marks to cross the zero level and the subsequent opposite threshold to cause an output toggle, this method is immune to the marking-pulse tails that poorly or nonequalized lengths of transmission line cause (Figure 3c and d). This effect gives rise to the possibility of eliminating the amplitude/frequency-equalizer portion of the receiver for high-bit-rate data transmission on medium-length copper cables.

A circuit that fulfills the receiver algorithm is a Schmitt trigger with an upper trip point and a lower trip point that are above and below the midlevel of the AMI three-level signal. You can easily set this point as a hardware bias with ac coupling of the dc-balanced AMI signal because there is virtually no baseline wander with AMI (Figure 4). Gain and drive level are not critical as long as sufficient pulse amplitude exists to cross the trip thresholds. If the signal is excessively strong or the trip thresholds are close to the midsignal level, the circuit still correctly translates data as long as no end-of-pulse ringing crossing into the opposite trip thresholds occurs. If this scenario occurs, pulse tails are beneficial, and you can artificially introduce them for the minimum operational cable length if necessary. For some oscilloscope-photo waveforms using the ECL Schmitt trigger of Figure 4, go to www.edn.com/080306di. EDN

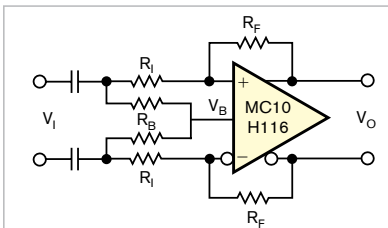

Figure 4 An MC10 H116 configured as a Schmitt-trigger circuit uses an ECL-amplifier stage. R_f supplies the positive feedback; the ratios of R_f to R_i set the hysteresis and thus the upper- and lower-trip-point-voltage levels. To remain within the linear region of the MC10 H116 transfer function, ± 100 to 200 mV from center zero level is suggested.

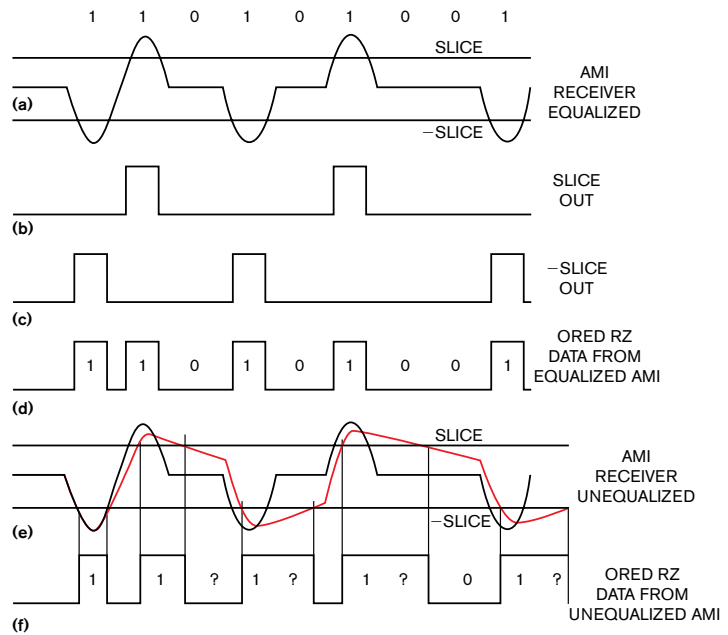

Figure 2 These waveforms show the usual transcoding of AMI to RZ. Two digital comparators slice bandlimited, equalized AMI (a). ORing the comparators, one for positive polarity (b) and one for negative polarity (c) produces RZ data (d). The digital comparators may themselves be Schmitt triggers for clean switching and immunity to small noise levels riding on the analog AMI. Unequalized AMI, superimposed on equalized AMI (e) causes the marking pulse tails, resulting in a highly distorted and error-filled RZ data waveform (f).

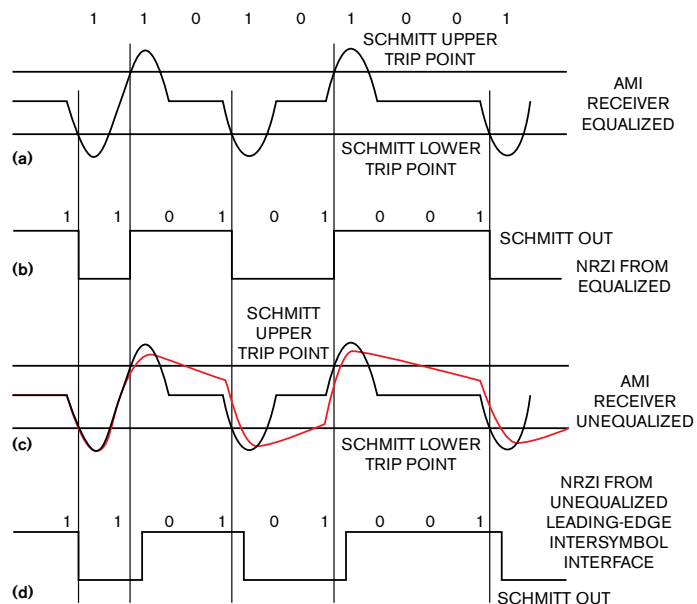

Figure 3 A Schmitt trigger directly converts bandlimited, equalized AMI (a) into the original NRZI (b). Once AMI crosses a trip point, no further transition at Schmitt output (c) is possible until the AMI crosses the opposite trip point. Unequalized AMI, superimposed on equalized AMI, cause marking pulse tails, resulting in little waveform distortion (d). Some data-dependent timing jitter occurs because of leading-edge intersymbol interference.

Virtual RF generator measures load impedance and power

Michael Nasab, Circuit Mentor, Boulder Creek, CA

Calculating the load impedance and power consumption at high frequencies in RF circuits is a tedious task. This Design Idea describes a VI (virtual instrument) that provides an easy way to quickly and effectively measure these parameters. You can measure and display the power and impedance of various types of loads, such as resistive or series/parallel tank circuits, at any given frequency. Using National Instruments (www.ni.com) LabView, you can easily modify the VI to accommodate any type of load having any complexity. The virtual RF generator comprises power-supply, amplifier, and load-select/measurement-display modules.

The amplifier module, with as much as 90% efficiency, provides frequencies of 100 kHz to 1 MHz with ad-

justable ac power applied to the load. The load-select-and-display module provides a sine or square waveform,

load-selection type, and adjustment.

Figure 1 shows the VI driving a resistive load. Adjusting the frequency from minimum to maximum has no effect on the output impedance and power. You can download the VI and watch a flash movie describing three examples at www.circuitmentor.com. **EDN**

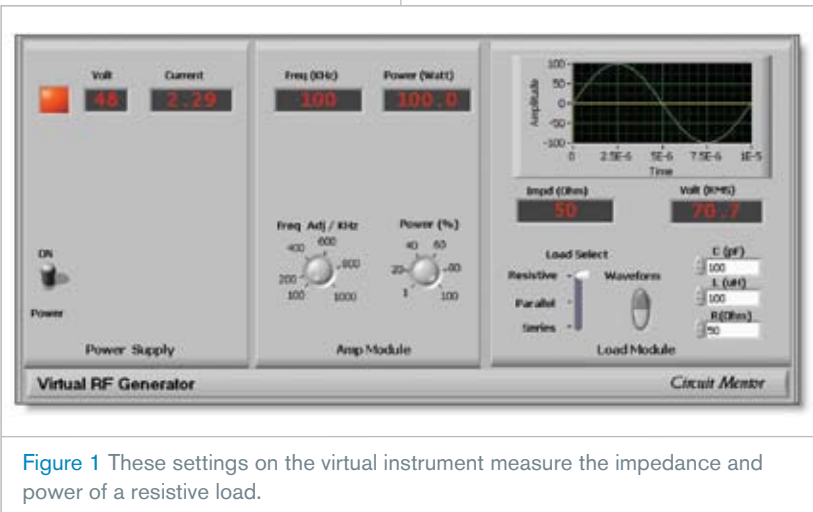

Figure 1 These settings on the virtual instrument measure the impedance and power of a resistive load.