

## DESARROLLO DE UN MÓDULO LED PARA LOS PROTOTIPOS DE FAROS DELANTEROS Y TRASEROS DEL SEAT ALTEA

V. Oliveras Mérida <sup>(p)</sup>, C. Elvira Avila, O. Bujedo Quintana, F. Dorca Badia, J.M. Marco Ortega.

### Abstract

Among the exterior design features, headlamps and rear lights play a key-role in the style's definition of a vehicle. For this reason, the design of the optical devices for this car had to be a completely different concept that transmits a technological feeling. Therefore, SEAT's designers did almost immediately think in using LED light sources.

Altea prototipo set the basis for the new lighting system concept. It included a metallic older with two opposed LEDs (a white and an amber one) assembled, for the position light and turn indicator functions. To avoid thermal problems, the original concept also included a small fan to provide forced ventilation.

Designer, usually try to use the same "styling language" in front and rear lights. Therefore Altea prototipo used the same concept in the headlamps as well as in the rear lights.

Concept cars are great to show new ideas and its feasibility, but usually the concepts shown there do not fulfil completely all regulations. That is, the design concept was already set, but there was still a lot of work to be done to achieve a functional solution that can be used in a real car development.

Once finished the concept phase, the real development has started. The new module must of course fulfil all legal and technical requirements: photometry of both lighting functions, thermal requirements, lifetime, mechanical requirements.

*Keywords: automotion, design, lights, leds*

### Resumen

De entre todos los elementos de diseño exterior, los faros delanteros y traseros juegan un papel fundamental en la definición del estilo del vehículo. El diseño de los dispositivos ópticos para este coche tenía que ser un concepto completamente diferente, que transmitiera una sensación de tecnología. Por esta razón, los diseñadores de SEAT pensaron inmediatamente en usar dispositivos LED.

El prototipo Altea sirve de base para un nuevo concepto en su sistema lumínico. Incluye un soporte metálico con dos LED opuestos (uno blanco y uno ámbar) dispuestos para las funciones de luz de posición y giro. Para evitar problemas de temperatura, el diseño inicial también incluye un pequeño ventilador para proveer de ventilación forzada.

El diseñador normalmente trata de usar el mismo "lenguaje de estilo" en las luces delanteras y traseras, por ello el prototipo Altea usa el mismo concepto en los faros delanteros y traseros.

Los coches conceptuales son óptimos para mostrar nuevas ideas y su viabilidad, pero normalmente los diseños mostrados no cumplen por completo todas las normas. Así pues, tras establecer el diseño conceptual, hay mucho trabajo que hacer para proponer una solución funcional que puede ser usada en el desarrollo de un coche real.

Una vez finalizada la fase conceptual, empieza el desarrollo real. El nuevo módulo debe, obviamente, cumplir todos los requerimientos legales y técnicos: fotometría de ambas funciones lumínicas, requerimientos termales, tiempo vida, requerimientos mecánicos, etc.

Palabras clave: automoción, diseño, faros, leds

## 1. Purpose and Aim of the Project

Emotion is the driving force behind SEAT's new design strategy. The company's goal is bring to the market reliable, high quality cars with an astonishing style that combines beauty with a strong high-tech-feeling. Within this philosophy, Altea Prototipo was the concept car designed to show these new ideas.

Among the exterior design features, headlamps and rear lights play a key-role in the style's definition of a vehicle. For this reason, the design of the optical devices for this car had to be a completely different concept that transmits a technological feeling. Therefore, SEAT designers did almost immediately think in using LED light sources.

SEAT's designers and lighting engineers working together side by side achieved a functional solution that could be shown in this concept car.



Figure 1. Development o fan LED Lighting Module for Rear Lights

Nevertheless there was still a lot of work being done to develop optical parts that are suitable for use in a series car.



Figure 2. Front Light of the Altea Prototipo

## 2. Description of the Developed Product

### 2.1 From Concept to reality

Altea Prototipo has defined the basis for the new lighting system concept. Thinking about which functions could be performed by using LEDs, designers decided to use a module with two opposite LEDs performing the functions position light and turn indicator.

Designers usually try to use the same “styling language” in front and rear lights. Therefore Altea Prototipo used the same concept in the headlamps as well as in the rear lights. In the headlamps there were a white (position light) and an amber (turn indicator) LED. The rear module used the same concept, but in this case, the LED for position light is red.

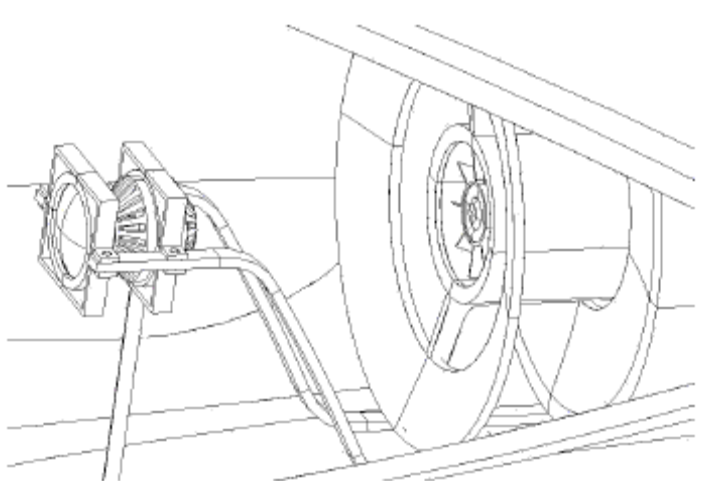

Figure 3 A concept sketch of the LED Module

Let's take a closer look to the structure of this concept module (look at the sketch). The concept module has two parts:

The first part includes a metal holder that holds both LEDs and a lens frame for the turn indicator.

The second part of the module includes a ring, which acts as a reflector for the position function and inside this ring a second ring that surrounds an electric fan for forced ventilation to avoid thermal problems



Figure 4 SEAT Altea Prototipo

A mock-up of this module has been developed and integrated into a Toledo's rear light housing.

The early concept of the LED-module was presented on the concept car Altea Prototipo in the Frankfurt International Motorshow 2003. The purpose was to show a new design trend, rather than the final solution that could be applied into a real car.

Concept cars are great to show new ideas and its feasibility, but usually the concepts shown there do not fulfill completely all regulations. That is, the design concept was already set, but there was still a lot of work to be done to achieve a functional solution that can be used in a real car development.

Once finished the concept phase, the real development has started. The new module must of course fulfill all legal and technical requirements: photometry of both lighting functions, thermal requirements, lifetime, mechanical requirements...

## **2.2 The real Project**

In 2006, the original idea was taken to convert it into a new one, retaining as much as possible of the original concept, but making it suitable for a series application. Notwithstanding, several visible aspects had to be changed.

As development partners for the construction of this module, SEAT has selected SEMAI and Yorka (ALRE). The first one has experience in LED and electronics and the second one in optics and is also the official supplier of the Altea's rear light.

The original active cooling with an electric fan has been changed into a passive cooling using a radiator instead of a fan. The shape of the twin-LED part has changed completely: the concept had a dish form; the new shape is a cylinder with an integrated radiator around the cylinder

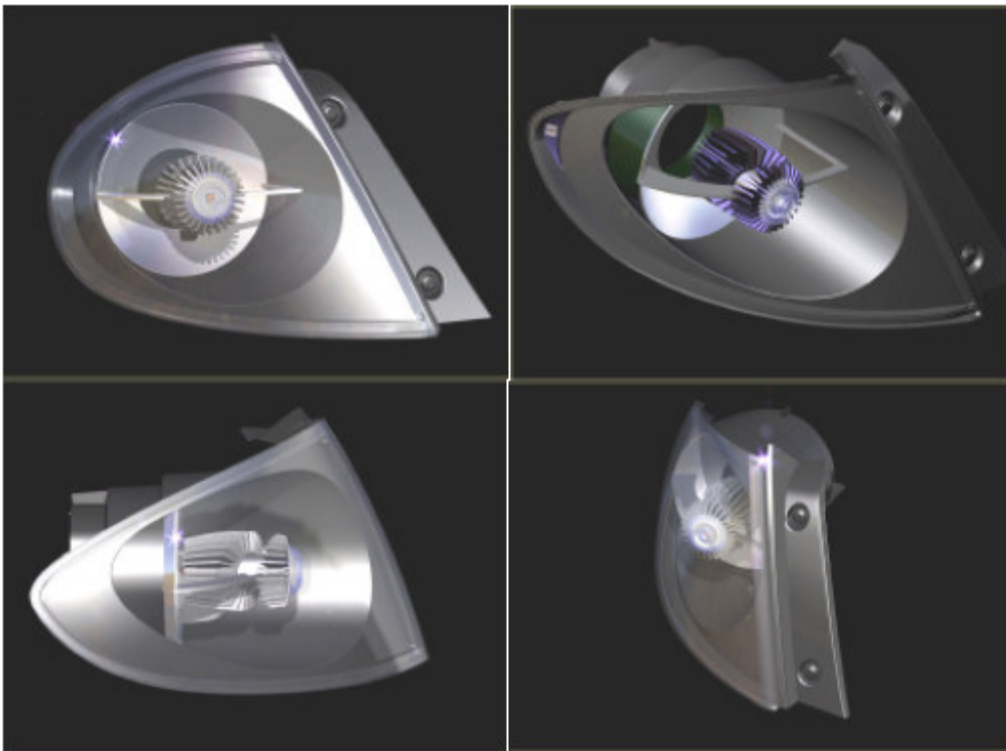
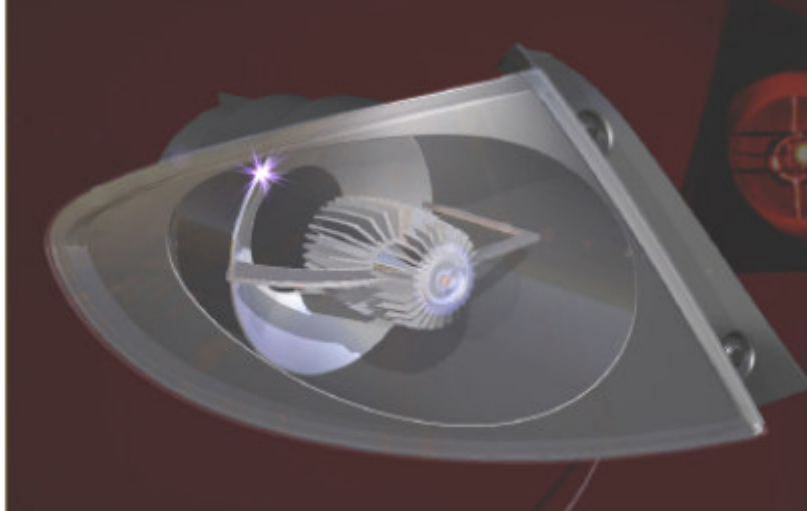

Figure 5 A render showing the aspect of the new LED module already integrated into a rear light housing

The requirements to the light distributions of the functions rear position light and turn indicator are defined in the ECE regulations.

The construction of a lighting device that fulfils these legal requirements means that the optical specialists have to work on the mathematics of the ring reflector surface and on the turn indicator's lens.

## 2.3 Development of production part

The project has been fully developed in all its standard phases, but in this case to bring to reality with short-series tooling to a fully operational and manufacturable part in a mass production car:

Optical photometry calculations, simulation and confirmation of homologation:

- Complex surface reflector for a Luxeon-III LED (red LHXL PD09) with no existing photometry predecessors in the market. Detail calculations not available due to confidentiality matters.
- Achievements of turn signal function with a single Luxeon-III LED (amber LHXL PL09) and a specifically calculated plastic lens.

System to parts break-down to a set of parts which:

- Fulfill mechanical and thermal stress.
- Define fixation & assemblability concept into a reliable set for automotive requirements.

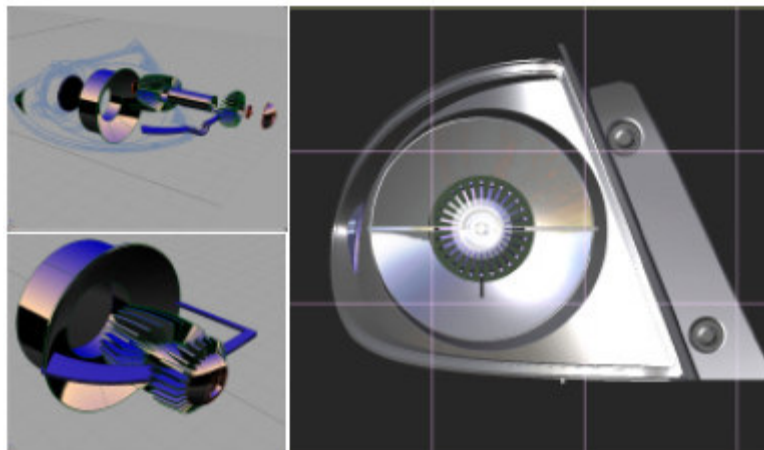

Industrialisation process:

- Detailed definition to become mould-injection feasible parts. Solving aesthetic implications for metallised visible surfaces to achieve quality requirements in a capable process.
- Aluminium blade-cooling radiators. Subassembly and finishing concept and process.
- Appearance and tolerances adjustments for mass production
- Final vehicle test for Quality and durability assurance under confirmation up to SOP release.

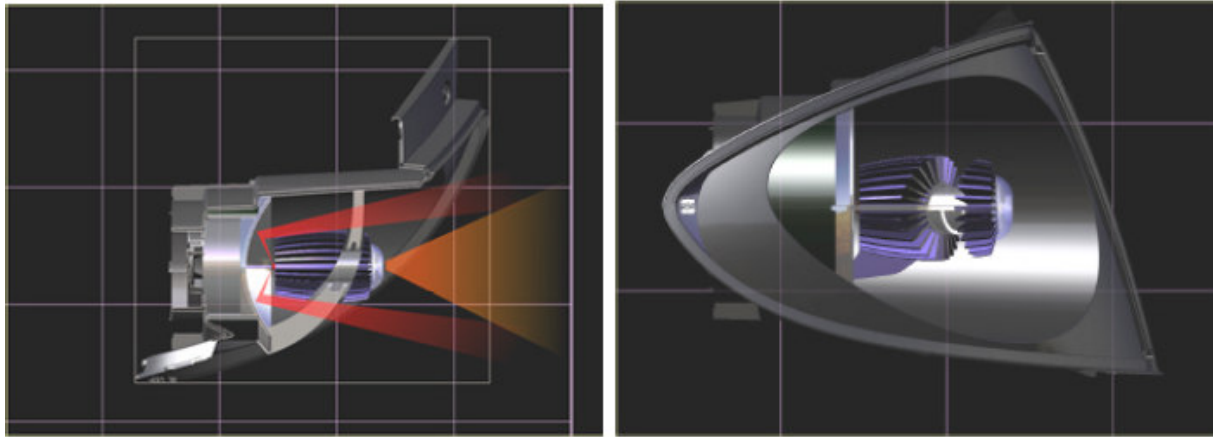

### 3 Innovations introduced with this project.

- First single LED Brake & Position functions achieving ECE R78 through complex reflector.
- First single LED TURN signal function achieving ECE R6 regulation.
- Twin function joint package with an aesthetic integrated cooling system.

### 4. Time Schedule

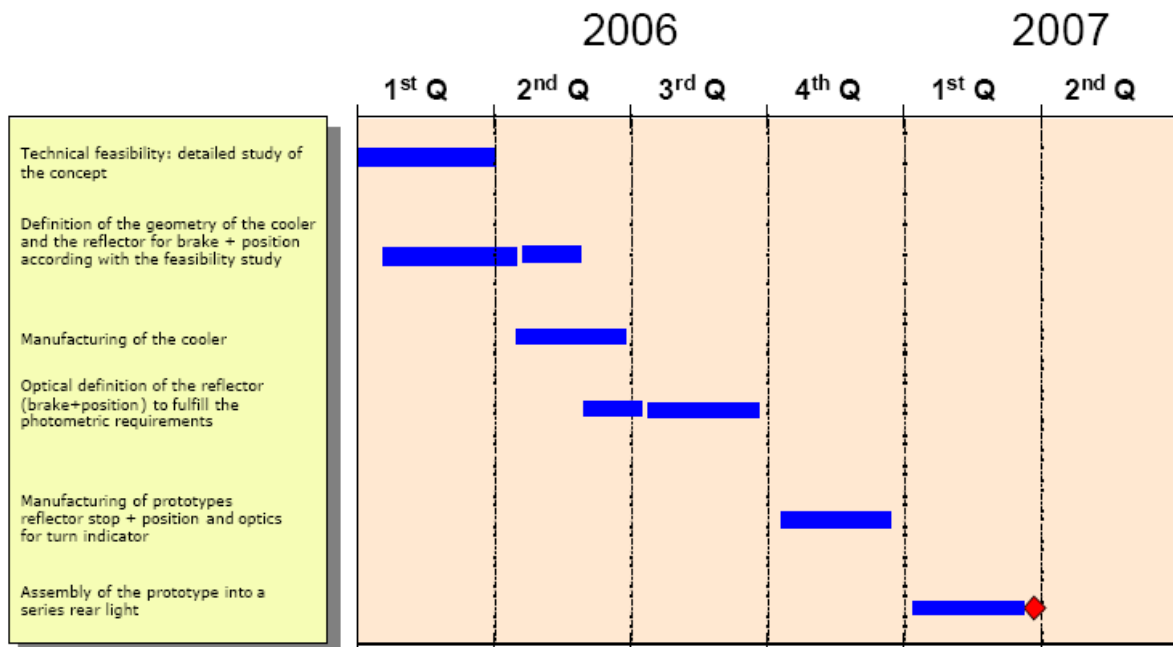

## 5. Resources Dedicated to the Project

For the development of this project, at SEAT one person was working on it part-time and at both SEIMA and Yorka also one person was working on the project part-time during 15 months.

Several CAD files were made and physical prototypes were manufactured during the project.

The specific economic figures are not available due to confidentiality matters.

## 6. Incidence of the Project in the Company

This project was finally concluded with positive results. Now the new module fulfils all technical requirements and legal prescriptions.

This solution could be used in a near future as a high-tech solution for SEAT series cars. It is a futuristic artwork that comprises beauty, creativity, emotion, technology... and therefore transmits very well to the customer the message of the company: “**SEAT auto emoción**”.

## 7. Company's Overview and details

SEAT S.A. is the only automobile brand in Spain with the ability to design, develop and produce its own vehicles. Its capacity of innovation is also demonstrated by the fact that SEAT is the only car producer that runs an own design centre in Spain. More than a thousand employed engineers and designers, as well as 70 patents registered last year, ensure SEAT's position as one of the private enterprises that dedicates most resources to research and development (R&D) in Spain.



## 8. Details

This development is the result of a continuous feedback between fresh styling proposals and the technical evaluation of their feasibility. Development activities are running to convert this concept into real optical devices that fulfill all legal and technical requirements to be used in a real series car. According to this development philosophy, a designer was responsible from the styling point of view and a lighting engineer for the study of the technical feasibility.

### Design

Oscar Bujedo Quintana  
Exterior Design  
Style definition of front / rear lights

### Lighting Development

Carles Elvira Àvila  
Lighting Development  
Head of department



### **Electric Development**

Juan Manuel Marco Ortega.  
Electric & electronic manager

F. Dorca Badia  
Illumination and Signaling

## **9 Correspondence**

Víctor Oliveras Mérida.  
I+D Coordinator  
Centro Técnico de SEAT S.A.  
Autovía A2, km 585 -08760 Martorell. Spain  
Phone: +34 93 773 1788  
E-mail: victor.oliveras@seat.es  
URL: <http://www.seat.es>