

Conference Paper

Improvement of Efficiency of Air Cooling Devices By Creation of Independent Modules with Evolvent Profile Composition of Finned Tubes

Eldar Rinatovich Abdeev, Rail Idiatovich Saitov, Rinat Gazizyanovich Abdeev, and Emil Irikovich Shavaleev

Bashkir State University, Ufa, Russia

Abstract

An analysis of the composition of the heat-exchange equipment at the petrochemical plants reveals that nominally more than 30% (and by weight about 50% of the total equipment) is heat-exchange equipment, including air-cooled units requiring replacement and reconstruction as a result of the end of their service life or corrosion erosion wear. Therefore, work aimed at improving the effectiveness of ABO is relevant. The existing problem of reducing the efficiency of air cooling in hot calm weather is compounded by the need for short-term humidification using a humidifier mounted directly behind the fan wheel when the air enters the diffuser. This dramatically increases the processes of corrosion and the formation of deposits on the surface of finned tubes (scale, fluff and dust). We have carried out a set of computational and experimental studies to evaluate the thermal efficiency of small-sized ABOs of various designs using a universal experimental industrial bench. The results of studies have established that vertical-cylindrical ABO designs are more energy-efficient and less metal-intensive compared to typical horizontal ones and allow for the influx of cold atmospheric air to the ABO inlet during the hot season.

Keywords: air cooler; heat transfer coefficient; thermal efficiency; design of a vertical cylindrical air-cooling apparatus; involute profile layout.

Corresponding Author:

Eldar Rinatovich Abdeev
air@bgutmo.ru

Published: 31 December 2020

Publishing services provided by
Knowledge E

© Eldar Rinatovich Abdeev
et al. This article is distributed
under the terms of the [Creative Commons Attribution License](#),
which permits unrestricted use
and redistribution provided that
the original author and source
are credited.

Selection and Peer-review under
the responsibility of the
TECHNOGEN-2019 Conference
Committee.

When operating air cooling units (ACU) in hot calm weather, a short-term moistening of the cooling air leads to an increase in thermal resistance on the cooling surface of the finned tubes. Together with fluff and dust deposited on a cooling surface contaminated with cutting fluid (CF) during manufacture, the heat transfer coefficient can be reduced by half already in the first season of operation of the ACU [1, 2].

As is known, the ambient temperature decreases with increasing height above the ground [3]. For example, at an altitude of 1000 m, in the lower layers of the troposphere in central Russia, the ambient temperature can range from - 8.5 to 2 °C, while on the surface of the earth it will be 15 - 35°C. Therefore, at a temperature of 26.5 °C on the surface of the earth, through the use of cooling air flows from a level of 1000 meters

OPEN ACCESS

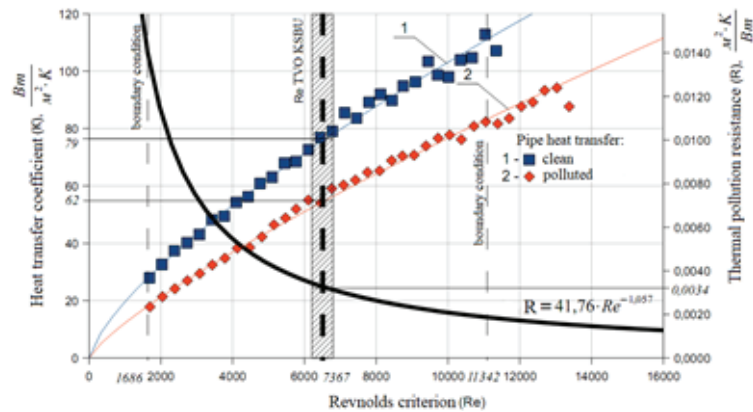

Figure 1: Comparison of the heat transfer coefficient of contaminated and cleaned finned tubes.

above the ground, it is possible to increase the thermal efficiency of the average ACU by 42.49%, which is confirmed by the calculations:

$$n = \frac{t_2 - t'_1}{t_2 - t''_1} \cdot 100 = \frac{39,8 - 26,5}{39,8 - 8,5} \cdot 100 = 42,49\% \quad (1)$$

where $t'_1=26,5$ - air temperature at the ground in hot weather, °C;

$t''_1=8,5$ - air temperature at an altitude of 1000 meters above the ground, °C;

$t_2= 39,8$ - cooling air temperature at the outlet of the ACU, °C.

The calculated values are in good agreement with the results of a generalization of the experimental data presented in Figure 2 for the vertical cylindrical structure of an air cooling units with a radial-diffuser arrangement of finned tubes.

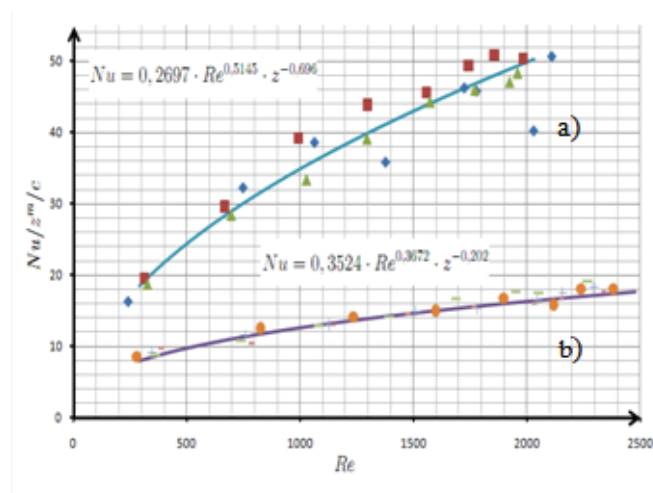

Figure 2: The results of the study of the thermal efficiency of the layout of pipes ACU where: a - radially diffuser and b - chess horizontal, layout; $Nu/z^m/c$ - dimensionless thermal efficiency complex; Re - air speed mode in a narrow section

We have developed a new design of a vertical cylindrical air cooling units (ACU-VC), using the radial-diffuser arrangement of finned tubes, instead of the classic horizontal staggered one. But a significant drawback of the radial-diffuser arrangement was the

inability to create more than 4 rows of pipes in the tube bundle of the heat exchange section. The impossibility of creating 5th and more rows lies in the intersection of the bundle of finned tubes of the third and fifth rows, as shown in Figure 3a, resulting from the degeneration of a rhombus forming a radial-diffusion arrangement. To solve this problem, we developed an involute profile layout shown in Figure 3b, which has no restrictions on the layout of the number of rows in the heat exchange section.[3].

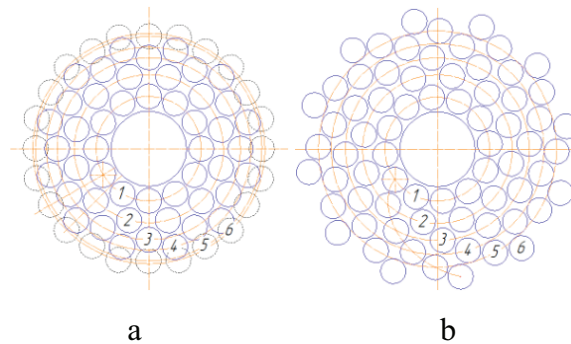

Figure 3: Comparison of radial diffuser and involute-profile layouts where: a - radial diffuser arrangement; b - involute profile layout.

For the convenience of calculating and designing ACU-VC, a mathematical model of a tube bundle coil with an involute-profile arrangement has been developed, which is presented in Figure 4 and described by formulas 2 and 3.

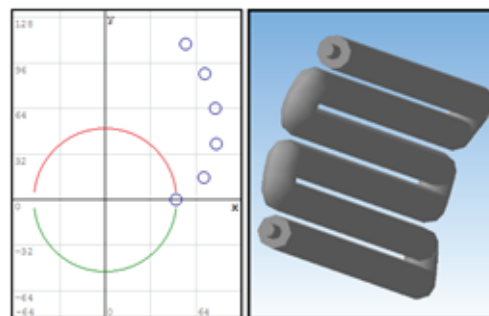

Figure 4: The mathematical model of the tube bundle coil

The profile bend of the finned tube of the base module ACU-VC is in the form of an involute, described by the system of equations:

$$\begin{cases} x_t = r \cdot (\cos(\varphi_t) + \varphi_t \cdot \sin(\varphi_t)) \\ y_t = r \cdot (\sin(\varphi_t) - \varphi_t \cdot \cos(\varphi_t)) \end{cases} \quad (2)$$

where r - radius circle involute;

t - involute point index;

φ - involute angle.

All $k \in t$ (points lying on this involute) are the centers of the circles designating the transverse section of the finned tube (Figure 4) of the tube bundle coil having the dashed coordinates of the centers under the condition:

$$L = \sqrt{(x_t - x'_k)^2 + (y_t - y'_k)^2} \quad (3)$$

where L - distance between the centers of circles;

t - index of points of circle centers.

In the new ACU-VC design, with an involute-profile layout of finned tubes, it is proposed to use the design of the ACU-VC base module, shown in Figure 5, which is an analogue of the design of the heat exchange section for modern horizontal ACU. A distinctive feature of this design is the use of metal structures and a fan unit, forming an autonomous module of the assembled ACU-VC, which allows to increase its overall performance without dismantling the entire structure. In the event of a failure of the fan or asynchronous motor of one of the modules, the rest will continue to work, since instead of the expensive low-speed asynchronous motor and fans with large unreliable blades, the ACU-VC base module uses a standard high-speed asynchronous motor and a centrifugal fan blade.

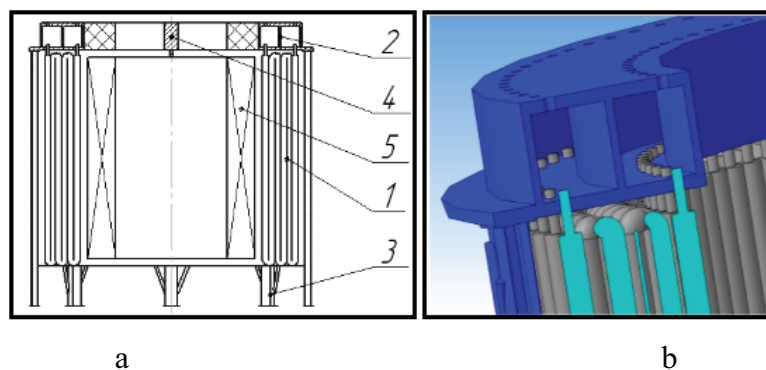

Figure 5: The basic module of the design of ACU-VC where: a - general view of the base module; b - collector section of a 3D model; 1 - a bunch of coils; 2 - toroidal collector; 3 - metal construction; 4 - high-speed asynchronous motor; 5 - air centrifugal fan.

The coil design of the finned heat exchanger pipe allows you to compensate for thermal expansion, which simplifies the design of the heat exchange section by eliminating the use of a thermal compensator. The cylindrical design of the toroidal collector, unlike the horizontal one, does not have thermal pullback during ring welding, and the compact design of the base module simplifies the assembly and rolling process. The design of the ACU-VCs base module allows you to create a fixed standard size series of ACU, abandon the manufacture of finned tubes less than 12 meters in length and finally standardize the design of the ACU by performing thermohydraulic calculations of the ACU by the number of basic modules.

The design of the ACU-VCs base module allows controlling the direction of cooling air flows at the inlet and outlet, due to which it is possible to control the recirculation of cooling air for the winter and summer time of the year and protect the cooling surface from fluff and dust.

When comparing the modern horizontal ACU with the ACU-VC (Figure 6), it is clear that the ACU-VC occupies a smaller production area than the horizontal one, and also has a cylindrical structure characteristic of petrochemical plants, while the ACU-VC are inferior to the columns in height, i.e. separate height approvals are not required. The weight of the horizontal ACU to be compared is 10 tons, a 200 tonne crane is used for the installation of each device, for a ACU-VC consisting of 7 basic modules weighing up to 2 tons each, a crane with a lifting capacity of 50 tons is used, which reduces the time and cost of transportation and installation apparatus.

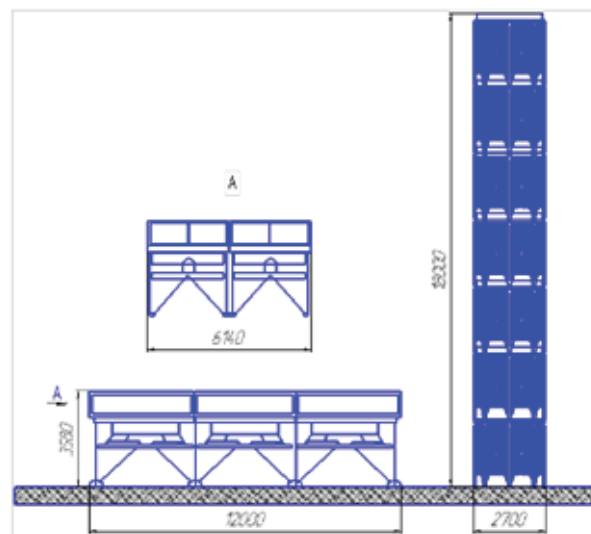

Figure 6: Comparison of horizontal ACU and ACU-VC

The use of ACU-VC with the involute-profile arrangement of finned tubes of the base module allows solving a number of problems at all stages of the life cycle of the apparatus of oil and gas and chemical industries, such as: the freezing of extreme pipes during a chess layout in the cold season during operation is solved by the cylindrical design of the tube bundle; mechanical deformation of process pipes during thermal expansion of the heat exchange section is solved by the use of finned tubes in the form of a coil; the use of expensive low-speed asynchronous motors to drive unit unreliable plastic or heavy metal blades, due to the separation into basic modules with an autonomous fan and drive unit; the difficulty of transporting 12-meter heat-exchange sections and non-separable metal structures; a large area of air coolers; individual and small-scale production of tube bundles of heat-exchange sections; contamination of the cooling surface of the finned tubes due to the control of the air flow of the cooling air;

recirculation of cooling air in hot calm weather; recirculation of cooling air in hot calm weather; withdrawal during welding of the collector, due to the use of the cylindrical design of the base module; uneven speed of the incoming flow of cooling air and its slipping past the cooling surface.

Thus, the use of the vertical ACU design, consisting of basic modules, ensures the density and uniformity of tube bundle packing due to the involute-profile layout, and the mathematical model allows you to speed up the ACU design process.

This work was supported by the RFBR grant No. 18-29-24178

References

- [1] Bessonny, A. N., *et al.* (1996). Basics of Calculation and Design of Air-Cooled Heat Exchangers: Reference Book. St. Petersburg: Nedra, p.512.
- [2] Abdeev, E. R., *et al.* (2011). Development of Energy-Efficient Air-Cooling Units with Optimal Layout of Tube Bundles of Heat-Exchange Sections. *Oil and Gas Business*, vol. 9, issue 4, pp. 56-61.
- [3] Abdeev, E. R., Abdeev, R. G. and Lobanov, M. A. (2016). Designing an Energy-Efficient Vertically Cylindrical Air-Cooled Apparatus with an Involute-Profile Tube Bundle. *Reports of Bashkir University*, vol. 1, issue 3, pp. 502-507.