



A new automated method for measuring noble gases and their isotopic ratios in water samples

Rachel H. R. Stanley

Department of Geosciences, Princeton University, Princeton, New Jersey 08542, USA (rstanley@princeton.edu)

Burkard Baschek

Department of Atmospheric and Oceanic Sciences, University of California, Los Angeles, California 90095, USA

Dempsey E. Lott III and William J. Jenkins

Department of Marine Chemistry and Geochemistry, Woods Hole Oceanographic Institution, Woods Hole, Massachusetts 02543, USA

[1] A method is presented for precisely measuring all five noble gases and their isotopic ratios in water samples using multiple programmed multistage cryogenic traps in conjunction with quadrupole mass spectrometry and magnetic sector mass spectrometry. Multiple automated cryogenic traps, including a two-stage cryotrap used for removal of water vapor, an activated charcoal cryotrap used for helium separation, and a stainless steel cryotrap used for neon, argon, krypton, and xenon separation, allow reproducible gas purification and separation. The precision of this method for gas standards is $\pm 0.10\%$ for He, $\pm 0.14\%$ for Ne, $\pm 0.10\%$ for Ar, $\pm 0.14\%$ for Kr, and $\pm 0.17\%$ for Xe. The precision of the isotopic ratios of the noble gases in gas standards are $\pm 1.9\%$ for $^{20}\text{Ne}/^{22}\text{Ne}$, $\pm 2.0\%$ for $^{84}\text{Kr}/^{86}\text{Kr}$, $\pm 2.5\%$ for $^{84}\text{Kr}/^{82}\text{Kr}$, $\pm 0.9\%$ for $^{132}\text{Xe}/^{129}\text{Xe}$, and $\pm 1.3\%$ for $^{132}\text{Xe}/^{136}\text{Xe}$. The precision of this method for water samples, determined by measurement of duplicate pairs, is $\pm 1\%$ for He, $\pm 0.9\%$ for Ne, $\pm 0.3\%$ for Ar, $\pm 0.3\%$ for Kr, and $\pm 0.2\%$ for Xe. An attached magnetic sector mass spectrometer measures $^3\text{He}/^4\text{He}$ with precisions of $\pm 0.1\%$ for air standards and $\pm 0.14\%$ for water samples.

Components: 12,234 words, 6 figures, 6 tables.

Keywords: noble gas; oceanography; mass spectrometry; seawater; isotope; cryogenic.

Index Terms: 4820 Oceanography: Biological and Chemical: Gases; 4803 Oceanography: Biological and Chemical: Analytical chemistry; 1065 Geochemistry: Major and trace element geochemistry.

Received 11 February 2009; **Revised** 6 April 2009; **Accepted** 9 April 2009; **Published** 29 May 2009.

Stanley, R. H. R., B. Baschek, D. E. Lott III, and W. J. Jenkins (2009), A new automated method for measuring noble gases and their isotopic ratios in water samples, *Geochem. Geophys. Geosyst.*, 10, Q05008, doi:10.1029/2009GC002429.

1. Introduction

[2] Noble gases are biologically and chemically inert and have a wide range of solubilities and diffusivities, making them useful environmental tracers. Noble gases have been measured in sea-

water, groundwater, ice cores, and rocks in order to address a variety of important problems in environmental science such as air-sea gas exchange, marine biological production, groundwater temperatures, firn temperature and thickness, surface exposure ages, etc. Quadrupole mass spectrometry

(QMS) and magnetic sector mass spectrometry have often been used to measure the noble gases in water samples. Recently, instruments have been developed that measure all five noble gases from a single sample [Poole *et al.*, 1997; Beyerle *et al.*, 2000; Kulongoski and Hilton, 2002; Sano and Takahata, 2005]. The analysis is usually conducted by isotope dilution or by peak height comparison with an air standard. The noble gases are commonly chemically purified and then condensed onto a charcoal trap at liquid N₂ temperatures (77 K), on a charcoal trap at dry ice/acetone temperature (96 K), or on a glass trap at liquid He (4 K). Methods that measure all five gases from a single sample have precisions of 0.3% to 1.0% using a magnetic sector instrument [Beyerle *et al.*, 2000] and 0.4% to 1.6% using a QMS system [Sano and Takahata, 2005]. Methods that only measure one of the noble gases may have better precisions. For example, an isotope dilution method for measuring only Ne obtained precisions of 0.13% [Hamme and Emerson, 2004].

[3] We have developed an automated sample processing and measurement system for the determination of the concentrations and isotope ratios of all five noble gas at the 0.1–0.2% level. The novel part of our method is the use of three programmable cryogenic traps, with their temperatures under precise computer control, in order to purify, trap, and sequentially release the gases one by one into each of two different mass spectrometers. The objective of the system design is to allow the concentration measurement of each of the five noble gases to per mil accuracy, despite there being five orders of magnitude difference in the abundances of the noble gases in seawater. The separation of the gases before they enter the QMS reduces the potential for interference between gas species and allows optimization of the gas pressure in the QMS, leading to more precise and accurate measurements. Were samples measured without any separation, it is likely that ions of the more abundant noble gases would interfere with measurements of the other gases through ion collisions or preferential ionization. Additionally, specific interferences in noble gas measurements include doubly charged Ar interfering with the measurement of ²⁰Ne, and doubly charged CO₂ interfering with the measurement of ²²Ne.

[4] We measure the gases using peak height manometry which allows us to measure the natural abundances of the isotope ratios of the noble gases. Our precision is already very good and could

possibly be improved further if we used isotope dilution but then we would not be able to obtain the isotope ratios. In this paper, we describe the method used to determine noble gas concentrations in water samples. The method could easily be extended to measuring the full suite of noble gases in air or ice samples.

[5] In section 2, we describe in both general terms (section 2.1) and in detailed terms (sections 2.2 and 2.3) the method for measuring the noble gas abundances and isotopic ratios on this dual mass spectrometric system. We report on the performance and reproducibility of this method in section 3. In section 4, we include a discussion of some problems we encountered while developing this method, as our solutions to these problems may be helpful to others trying to build similar systems.

2. Methods

[6] The methods for measuring the gases is described briefly in section 2.1. Then, for those readers who may wish to duplicate our system, we describe in much more detail the steps necessary for measuring an air standard or sample (section 2.2) or a water sample (section 2.3). The remaining two subsections give the details of the QMS procedure and of standardization. An overview of the steps involved in making a measurement, including the details of the timing and the trap temperatures are recorded in Table 1. All the trap temperatures for the cycles as well as the pumping times were optimized for the best performance and shortest time on this particular system.

2.1. General Description

[7] The sample processing and measurement system is shown in Figure 1. Noble gases previously extracted from a water sample or gas standard are sequentially drawn through a two-stage water vapor cryotrap (WVC) to remove water vapor, through a Pd catalyst and getters for chemical purification, and then onto two cryogenic traps. The WVC (Figure 2) is a two-stage flow through cryotrap with independently controlled temperatures allowing water vapor to be removed but the noble gases to pass through unimpeded. The activated charcoal cryotrap (ACC) at <10 K captures He and then at 40 K releases an aliquot of He into the QMS and the remainder into the helium isotope mass spectrometer (HIMS), a magnetic sector mass spectrometer, for precise measurements of ³He/⁴He ratios. The magnetic sector mass spectrometer is

Table 1. Brief Description, Including Details of Trap Temperature and Timing, of the Steps Involved in Analyzing an Air Standard

Step	Trap	Trap Temperature ^a (K)	Time (min)	Purpose
Draw Ne, Ar, Kr and Xe onto SSC	SSC	<9.5	12	Draw gases
Draw He onto ACC	ACC	<8.5	8	Draw gases
Cycle temp of SSC	SSC	W40, C < 9.5		Liberate He trapped under Ne
ACC pumps on SSC	SSC/ACC	<9.5	0.5	Transfer liberated He to ACC
Second draw on sample	SSC	<9.5	12	Warm WVC during draw to release gases from under ice
Temp cycle to liberate Ne	SSC	W60		Release any Ne trapped underneath Ar
Prepare for Ne release	SSC	C14, W25		Recondense Ne and warm to release temperature
Release and volumetrically split Ne	SSC	25		Release Ne into the QMS for measurement
Ion pump SSC to remove leftover Ne	SSC	20	2	Pump Ne but not any Ar
Release He from ACC	ACC	40		Release He into the QMS and HIMS for measurement
Release Ne from ACC	ACC	80		Release and measure any Ne trapped on ACC
Ion pump ACC to clean it	ACC	80	10	Clean out ACC before next sample
Temp cycle to liberate Ar	SSC	W80		Liberate Ar trapped under Kr or Xe
Prepare for Ar release	SSC	C25, W60		Recondense Ar and then warm to release temperature
Release and split Ar	SSC	60		Release Ar into QMS for measurement
Ion pump SSC to remove leftover Ar	SSC	62	2	Higher than release temp to try to get most of the Ar
Temp cycle to liberate a little more Ar	SSC	W155, C62		Liberate Ar trapped under Kr or Xe
Ion pump SSC second time	SSC	62	3	Remove the Ar liberated by temperature cycle
Release and split Kr	SSC	103		Release Kr into the QMS for measurement
Turbo pump SSC to remove leftover Kr	SSC	93	2	Remove the Kr left on the trap after the release
Temp cycle to liberate more Kr	SSC	W155, C93		Liberate any Kr to reduce amount of Kr inlet with Xe
Turbo pump to remove a little more Kr	SSC	93	2	Remove the Kr liberated by temperature cycle
Release and split Xe	SSC	155		Release Xe into the QMS for measurement
Pump out trap	SSC	W290	20	Clean out any gases remaining on the SSC
Cool traps	SSC/ACC	<10		Prepare for next sample by starting with cool traps

^aW indicates warm to stated temperature, and C indicates cool to stated temperature.

necessary for measuring helium isotope ratios given the six orders of magnitude difference in abundance between ³He and ⁴He as well as the need for high resolution to separate ³He from hydrogen deuteride (HD), both which have a nominal mass of 3.

[8] The stainless steel cryotrap (SSC) also initially at <10 K, captures Ne, Ar, Kr, and Xe and then selectively warms and releases the noble gases. After the gases are released from the SSC, they are volumetrically partitioned using different parts of the processing line and aliquoting volumes, in order to achieve count rates of 100,000 to 150,000 cps, an optimal counting rate for the secondary electron multiplier (SEM) which is operated in ion counting mode. Too high a counting

rate leads to dead time issues, a nonlinear response, and a short lifetime for the SEM. Too low a counting rate leads to poor Poisson ion-counting statistics. The gases are measured by peak height manometry in a statically operated QMS. Quadrupole mass spectrometers have a large mass range and quick response, allowing the measurements of all the noble gases. The system, including the processing line, cryotrap, and mass spectrometers, is operated under computer program control to achieve a high degree of reproducibility and for continuous operation.

[9] In order to avoid possible systematic biases caused by the interaction between gas species via ion collisions and preferential ionization within the mass spectrometers, we use cryogenic techniques

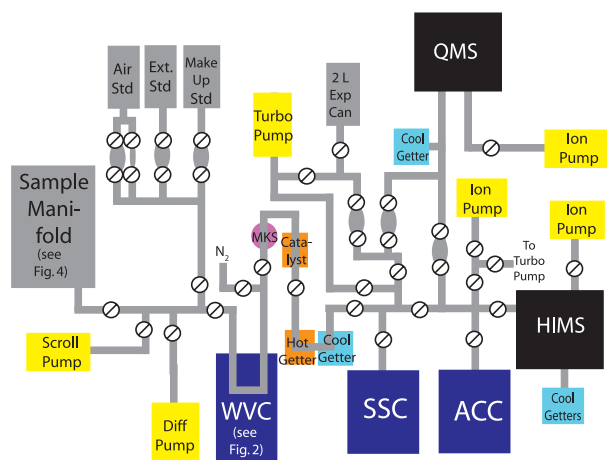

Figure 1. Schematic of the processing line and mass spectrometers (HIMS and QMS) that comprise the analytical system. White circles with slashes denote pneumatically actuated copper stem tip (vacuum-type) stainless steel UHV bellows valves (Nupro P/N 22-*BG-TW-CU-3C and SS-4BG-USI-VD-3C). Ovals represent aliquot volumes. All aliquots as well as the standard reservoir volumes and the 2 L expansion volume are in an aluminum box in order to keep them at an approximately constant temperature. “MKS” represents a capacitance manometer (MKS baratron PR4000 controller with 10 torr type 626A absolute pressure transducer). “WVC” refers to a two-stage cryotrap (inlet and outlet sides, see Figure 2) initially held at 180K to trap water in the sample. “ACC” and “SSC” refer to the activated charcoal and the stainless steel cryotrap, respectively. Yellow rectangles denote vacuum pumps. Backing pumps are not shown. There are bypass valves and tubing (not shown to increase clarity) that allow for direct pumping of the catalysts and getters.

to separate the noble gases before they are inlet into the mass spectrometers. Thus each of the noble gases is measured sequentially from the same air standard or water sample. The cryogenic systems used here lead to three cryogenic processes: cryocondensation, cryosorption and cryotrapping. “Cryocondensation” refers to the condensation of gas on a truly inert surface and results in the partial pressure of the gas above the surface being a function only of its vapor pressure at the trap temperature. However, no surface is truly inert, and thus the nature of the surface of the trap influences the amount of gas released. An active surface, such as on the ACC, results in stronger “cryosorption” and thus releases the gases at higher temperatures than a stainless steel surface such as on the SSC. For example, Ne is released at 25K on the SSC and at 80K on the ACC. “Cryotrapping” or occlusion refers to one gas being

trapped by another. Since Ar is three to five orders of magnitude more abundant than the other noble gases, Ar cryotrap the other gases and to a lesser extent Kr may cryotrap the Xe. We found that by cycling the temperature of the SSC while it is isolated, we can effectively layer one gas under another and thus can release gases that have been inadvertently cryotrapped. For example, we found that by warming and then cooling the SSC before we inlet Ne into the QMS, we measured 2% more Ne, presumably Ne that otherwise would have

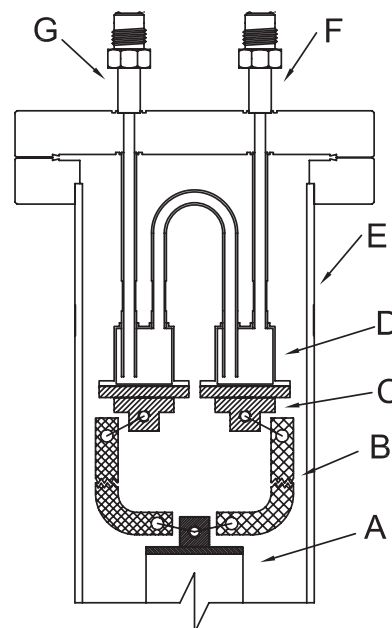

Figure 2. A cross-sectional view of the two-stage water vapor cryotrap (WVC) assembly. Cooling is provided by an ARS Model DE102 Cold Head (A) with an OFHC copper adapter. The thermal connection between the individual vapor traps (D) and the cold head is provided by 10 AWG copper flat braided cables (B). The cables are connected through OFHC copper block adapters (C) to the individual type 316 stainless steel traps. The temperature of each vapor trap is controlled using a SI Model 9700 temperature controller employing a 50 w cartridge heater and a SI 410A silicon diode mounted in each copper block. A 0.0127 cm (0.005 inch) thick, 99.9% pure, indium gasket is used between the mating surfaces of the copper block and trap to maximize thermal contact. The WVC assembly is housed in vacuum chamber (E). The gas sample enters through port (F) and exits through port (G). During sample processing the traps are operated between 180 K and 285 K (see text). The actual minimum temperature of the traps is ~47 K with the DE102 cold head operating at ~28 K. The maximum temperature of the traps is limited to <429 K by the indium gaskets and the maximum DE102 temperature of 350 K. The individual vapor traps can be held at different temperatures.

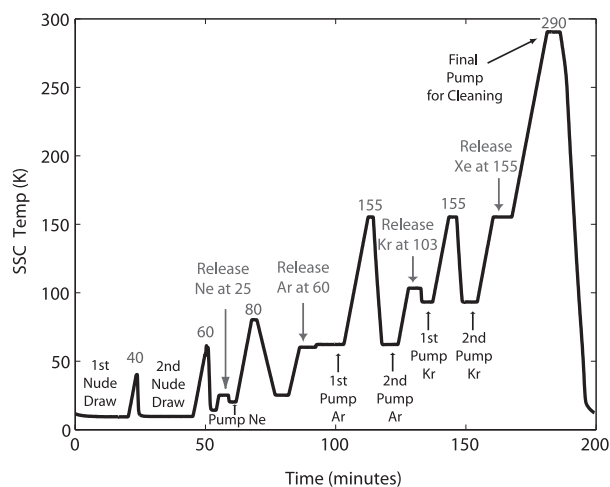

Figure 3. Temperature of the stainless steel cryotrap (SSC) as a function of time after beginning of analysis. The SSC undergoes a number of temperature cycles in order to reproducibly separate and release the noble gases. Gray arrows indicate where gases are released. Black arrows indicate where gases are pumped. Numbers indicate temperatures (K) at various points in the temperature cycles.

been trapped under the Ar. Also, by warming, cooling, and then pumping the SSC before releasing Kr, we can remove more Ar from the trap than we could without this temperature cycle and thus have less interference of Ar with our Kr measurements. Figure 3 illustrates the temperature cycles undergone by the SSC. By using a computer programmable cryotrap, rather than by dipping a tube into liquid N₂ or liquid He, we are able to precisely set the cryotrap to many different temperatures and take advantage of temperature cycling.

2.2. Method for a Gas Standard or Sample

[10] The processing line is pumped by a diffusion pump, a turbo molecular pump, and an ion pump in different parts of the line (see Figure 1) to below 5×10^{-8} torr before starting an analysis. An aliquot of an air standard or a sample first passes through the WVC, a two-stage cryotrap held at 180 K, in order to remove water vapor. Then it flows through a Pd catalyst (BASF catalyst R02-20/37), held at >450°C, where CH₄ in the standard is oxidized to CO₂ and H₂O. The pressure is recorded on a capacitance manometer (MKS baratron PR4000 controller with 10 torr type 626A absolute pressure transducer) in order to determine the total gas pressure. The gas then flows through a two-stage zirconium-vanadium-iron nonevaporable getter, composed of pellets of ST707 (available from SAES getters) in order to remove active gases. The

first half of the getter is heated to 350°C to chemically remove O₂, N₂, and CO₂ and to crack any remaining CH₄, while the second half of the getter remains at room temperature (20°C) to sorb H₂. The noble gases are inert to the getter pellets and flow through unimpeded.

[11] The sample is next drawn onto the SSC, held at less than 9.5 K. Neon, Ar, Kr and Xe are trapped on the stainless steel surface. Helium does not sorb quantitatively to the stainless steel surface at this temperature, so the sample is next exposed to the ACC [Lott and Jenkins, 1984] operated at 8.5 K in order to trap He. While the ACC is drawing the He, the isolated SSC undergoes a short temperature cycle (see Figure 3 for all the SSC temperature cycles) to liberate the 2% to 4% of the He that was cryotrapped by the other gases. The ACC subsequently pumps on the SCC in order to cryosorb this He onto the ACC; the other noble gases remain sorbed to the SSC.

[12] The sample is next drawn for a second time onto the SSC, while the inlet side of the WVC is warmed to 285 K and the outlet side of the WVC is held at 180 K. The ice is thus melted and the water is distilled onto the outlet WVC, releasing any gases that had been trapped in the ice for subsequent purification and cryotrapping while blocking water vapor.

[13] The SSC is warmed to 60 K and then is cooled back to 25 K in order to outgas and release Ne that had been cryotrapped by Ar. This temperature cycle was deemed necessary as it led to approximately 2% more Ne being released and to more reproducible results. At 25 K, the SSC is then opened and Ne is released from the trap. The amount of Ne released is volumetrically split by a factor of roughly 200 in a reproducible fashion by using the aliquoting valves and parts of the line and is then inlet into the QMS for analysis by peak height manometry. Because volume partitioning is used to split the Ne, some fraction of Ne remains on the SSC. This is removed by ion pumping the SSC at 20 K, which is 5 K less than the release temperature, in order to avoid any loss of Ar.

[14] Meanwhile, the ACC is warmed to 40 K and then is opened to release He. An aliquot of He, equal to approximately 1% of the sample, is inlet into the QMS. Next, the remaining 99% of the He is volume partitioned into the HIMS where the ³He/⁴He ratio is measured [Lott and Jenkins, 1984]. The HIMS, an improved system based on the “Clarke design,” is a purposely constructed

branch tube, statically operated, dual collector magnetic sector helium isotope mass spectrometer, with a radius of 25.4 cm, equipped with a Faraday cup and a pulse counting SEM.

[15] The ACC is then warmed to 80 K. An aliquot of gas is released from the ACC and analyzed for Ne, in order to quantify any Ne that did not sorb to the SSC but rather made it through to the ACC. The amount of Ne measured from the ACC is approximately 0.2% of the amount measured from the SSC for gas standards and approximately 0.5% of the amount measured from the SSC for water samples, suggesting the SSC exhibits a variable Ne trapping efficiency which is dependent on major gas composition, including possibly water vapor. The ACC is then cleaned by ion pumping at 80 K.

[16] Meanwhile, the SSC undergoes a temperature cycle to 80 K, is slowly cooled to 25 K, and then is warmed to 60 K where Ar is released. The purpose of this temperature cycle is to redistribute the gases on the trap, layering first the Xe on the SSC, then the Kr, and then the Ar and thus minimizes commingling of Ar and Kr. Because Ar is very abundant in air samples, the Ar sample must be reproducibly split down by a factor of approximately 3×10^6 in order to avoid overwhelming the QMS. Thus Ar is expanded multiple times into different parts of the line, including into a two liter stainless steel expansion can, to enable the consistent splitting with a reproducibility of 0.1%.

[17] In order to remove any Ar remaining on the SSC, the SSC is then turbo pumped at 62 K. This pumping temperature is higher than the release temperature in order to remove enough Ar so as to minimize interference with the Kr measurements. Then, in order to remove any Ar that still remains on the SSC, perhaps cryotrapped under Kr or Xe, a temperature/pumping cycle is performed. The SSC is isolated and warmed to 150 K, cooled back to 62 K, and then ion pumped. This heating and pumping cycles results in an acceptably low amount of Ar in our Kr and Xe samples: the Ar introduced into the QMS when the Kr is inlet produces an ion current that is about 20% of the Kr signal. It is possible to further reduce the amount of Ar in the Kr inlet by pumping for longer or at higher temperatures. However, this results in significantly greater Kr loss and deterioration of our Kr results.

[18] The SSC is isolated, warmed to 103 K and opened to release Kr. The Kr is split by a factor of approximately 130 and then is inlet into the QMS.

The SSC is cooled to 93 K and then turbo pumped to remove remaining Kr. The SSC is isolated and undergoes a heating/ion pumping cycle to remove any Kr cryotrapped by Xe. The SSC is next warmed to 155 K and opened to release Xe. The Xe is split by a factor of approximately six, and then inlet into the QMS. The SSC is turbo pumped briefly to remove any remaining Xe. The SSC is then ion pumped while being warmed to 290 K and pumped and held at 290 K for 5 min. Next the ACC and the SSC are cooled to <10 K in order to prepare for the next sample.

[19] The total analysis time for one sample is approximately 3 h and 20 min and the procedure is completely automated. Line blanks are run every few days in order to check for leaks and to assess the cleanliness of the system. Line blanks typically are smaller than 0.004% for He, Kr, and Xe, smaller than 0.01% for Ne, and smaller than 0.07% for Ar.

2.3. Additional Steps for a Water Sample

[20] Water samples consist of 90 g of water taken at sea (or for testing purposes in the laboratory) from Niskin bottles on a CTD rosette. The water is gravity fed from the bottles via Tygon tubing into valved stainless steel cylinders. Gases are extracted from the cylinders into aluminosilicate glass bulbs (approximate volume of bulb is 30 cm³) using an “at-sea extraction system” [Lott and Jenkins, 1998]. The glass sample bulb contains ~99.9% of the original sample amount for He, Ne, Ar, and Kr, ~99.7% of the original sample amount for Xe, and 3 to 5 cm³ of distilled water transferred during the extraction. These extraction efficiencies have uncertainties of <0.1% and are corrected for in all calculations.

[21] Because He, and to a lesser extent Ne, permeates through the viton O-rings in the cylinder plug valves, samples should be extracted as soon as possible, usually within 24 h of sample collection. Experiments performed with degassed water samples documented the rate at which samples are compromised. He and Ne were equilibrated at rates of 0.46% and 0.09% of their disequilibrium per day. Thus for a sample with a 10% disequilibrium in either He or Ne concentration or He isotope ratio, a 24 h delay in extraction from the time of sampling would lead to a signal reduction of 0.046%, 0.009%, and 0.046% for He concentration, Ne concentration and He isotope ratio, respectively.

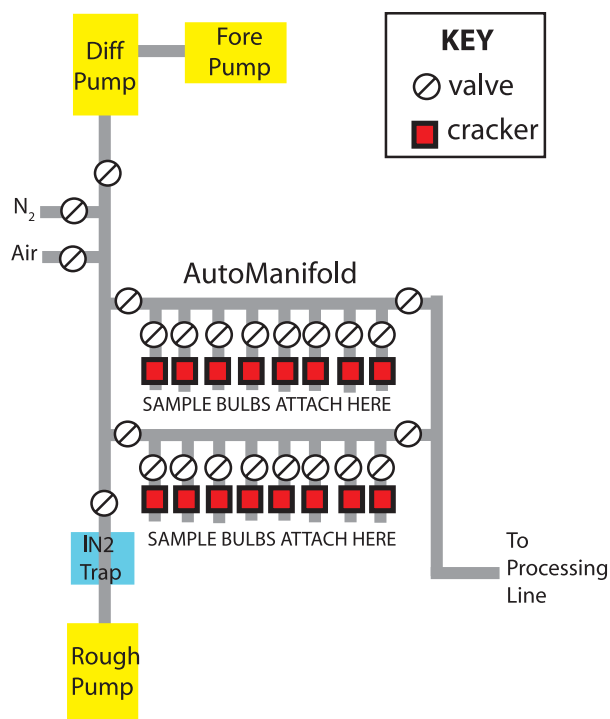

Figure 4. Schematic of the automanifold, used for attaching up to 16 glass water sample bulbs onto the processing line. White circles with slashes denote pneumatically actuated copper stem tip (vacuum-type) stainless steel UHV bellows valves. Red squares denote pneumatically operated crackers (see Figure 5). Yellow rectangles denote pumps. “IN₂ trap” refers to a trap chilled with liquid nitrogen to condense water vapor when initially pumping down the sample bulbs after attaching them to the automanifold; the sample bulbs are still sealed at that point.

[22] Sets of eight of these glass bulb samples are attached to the automanifold using viton O-ring compression fittings (Figure 4). The manifold is then pumped for at least 2 h, a processing blank is run to assess for any leaks, and then the samples are individually processed, with one gas standard being run after every two water samples. To process a sample, first all of the sample sections except the sample of interest are closed off, and the manifold is isolated from the vacuum pumps and the rest of the processing line. Custom-fabricated automated “crackers,” based on heavily modified Nupro valves (P/N SS-6-6BK-TW-10) and operated at a pneumatic pressure of 40 psi, snap the tip of the glass seal off the bulb (Figure 5), which allows the gas from the headspace of the sample bulb to be partitioned into the volume of the manifold. Above the cracker, there is a 60 micron frit followed by a 1 mm diameter by 13 mm long capillary, both of which aid in slowing the water transfer rate into the line while at the same time increasing the potential

for water vapor to sweep out the gas from the bulbs. Additionally the frit prevents any broken glass from entering the processing line.

[23] After 30 s, the manifold is opened. Some of the water in the sample bulb evaporates, acting as a water vapor pump that quantitatively sweeps all the gas through the capillary from the headspace out of the bulb into the processing line volume. After 1.5 min, the valve to the bulb is closed to avoid excessive water vapor transfer. Beyond this point, the sample gases are processed in an identical fashion to the standard gases. The WVC is cleaned between samples by blowing N₂ through the trap for 5 min.

[24] Some fraction of the gases are dissolved in water and thus not all the gas is drawn out of the bulb. This amount of gas left behind can be calculated from the volume and temperature of the water, the volume of the bulb, and the solubility of the gas. Additionally, it was determined experimentally on some samples by repeated drawing of gas from the same sample. Approximately 10 to

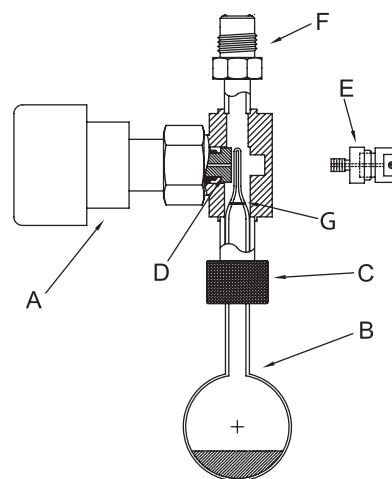

Figure 5. Cross-sectional view of the automated sample opening device referred to as the “cracker.” The cracker (A) is a highly modified pneumatically actuated normally open Nupro valve (P/N SS-6BK-TW-10). The aluminosilicate 30 cm³ glass sample storage vessel (B) is first “scored” at position G and then slipped into the cracker through the O-ring sealed compression fitting (C) to isolate it from atmosphere. Friction between the O-ring and bulb neck is enough to position the bulb correctly for opening. The sample is opened by applying 40 psi to the valve causing the “plunger” (D) to snap the bulb open at the scored position. A second view of the plunger (E) shows construction detail. The tabs on each side are used to limit the plunger travel to 0.25 cm. The cracker is attached to the manifold with a VCR fitting (F).

Table 2. Parameters Used by the QMS to Measure the Five Noble Gases in a Water Sample or Gas Standard

	He	Ne	Ar	Kr	Xe
Isotopes measured	⁴ He	²⁰ Ne, ²² Ne	⁴⁰ Ar, ³⁶ Ar	⁸⁴ Kr, ⁸⁶ Kr, ⁸² Kr	¹³² Xe, ¹²⁹ Xe, ¹³⁶ Xe
CryoTrap used	ACC	SSC and ACC	SSC	SSC	SSC
Release temperature (K)	40	25	60	103	155
Splitting factor	100	200	3×10^6	130	6
Number of scans by QMS	200	90	110	90	130
Emission (μ Amp)	20	20	40	40	20
Inlet time (s)	60	60	60	60	90

40% more gas was consistently drawn from the samples than the theoretical calculation predicted, suggesting that all the gas in the headspace plus some of the gas that was originally dissolved in the water was drawn. The ratio of the measured sample to theoretical sample left behind in the bulb is consistent for each position on the manifold and is used to correct all measurements for the amount of gas left in the bulb. Manifold positions that are closer to the WVC have less gas left behind because the WVC is more effective at drawing out the gas at shorter distances. Samples that are on the lower manifold also have less gas left behind because they are slightly warmed from below by the diffusion pump and gases are less soluble at warmer temperatures.

[25] We thus measure the ratio for each position on the manifold and correct each sample accordingly. This ratio is more difficult to calculate for He and Ne since He and Ne diffuse through the sample bulb O-ring seal into the bulb during the time period between sample and retake. In spite of repeated measurements of He and Ne left behind, the uncertainties on the left behinds of these gases remain large. However, since these gases are the least soluble, the absolute left behind is small, and thus even with these larger uncertainties, the error added by the correction is small. The size of the corrections ranges from $\sim 0.1\%$ for He to $\sim 2\%$ for Xe, with the uncertainty added by the correction ranging from 0.01% for He to 0.06% for Xe. Quantitative gas transfer could be achieved by complete distillation of the water, but that would lead to excessive “loading” of the vacuum system with water and thus longer sampling processing time in order to remove all the water.

[26] To assess whether any gas was left behind in the manifold or WVC, experiments were done in which the manifold and WVC were isolated after a sample was drawn and processed. The WVC was warmed to 285 K in order to melt the ice and release all gases and then cooled to 180 K. The gas in the WVC and manifold was less than 0.005% of

that contained in the sample, illustrating that the two-stage WVC successfully prevented gas from being trapped in the ice. If only a single-stage water trap were used, then 3% to 4% of the Ar (and presumably more of Kr and Xe) was trapped in the ice.

2.4. Details of QMS Analysis

[27] The QMS is a Hiden quadrupole mass spectrometer (P/N PCI 1000 1.2HAL/3F 1301-9 PIC type 570309), equipped with an electron impact ion source, triple quadrupole mass filter, and a pulse counting secondary electron multiplier (SEM). Scanning and data collection on the QMS commences immediately prior to isolation of the QMS from the ion pump. The gas sample is then expanded into the QMS for a specified inlet time (Table 2), while the QMS continues to measure the ion current of the selected isotopes. After the specified time, the inlet valve is closed and the QMS continues scanning for a total number of scans (Table 2), such that the overall analysis time is approximately 5 min. The QMS also measures other gases that have the potential to be large enough to influence the results, such as H₂, CH₄, CO₂, H₂O, as well as other noble gases as appropriate. These are monitored to ensure that these gases do not reach undesirable levels.

[28] Measurement of all isotopes is made at specific mass points rather than by scanning individual peaks. Typically the ion count rate changes over the course of the analysis by $<0.1\%$ for He, Ne, and Ar and by $<1\%$ for Kr and Xe. After the analysis of the sample is complete, we determine the linear fit to the mass peak ion count rate as a function of scan number (equivalent to time). This fit is used to extrapolate the ion count rate to the end of the inlet period in order to calculate a single representative ion count rate associated with the amount of a given isotope in a sample or standard. The ion count rate of a sample is then quantitatively compared to the ion count rate of the running standards (“std”) measured before and after the sample in

order to calculate the concentration of gas in a sample:

$$V_{\text{smp}} = V_{\text{std}} \times \frac{I_{\text{smp}} - I_{\text{blk, smp}}}{I_{\text{std}} - I_{\text{blk, std}}} \quad (1)$$

where V_{smp} is the volume of gas in the sample, V_{std} is the volume of gas in the standard, I_{smp} refers to the ion count rate for the sample, $I_{\text{blk, smp}}$ refers to the ion count rate measured when running the same procedure but without introducing a sample, I_{std} refers to the ion count rate for a standard, and $I_{\text{blk, std}}$ refers to the ion count rate when running the same procedure but without introducing a standard. The sample and standard blanks are statistically equivalent. We are explicitly assuming a linear relationship between ion count rate and the pressure of the gas and hence the sample size. Deviations from this relationship are determined empirically and are corrected for (see section 3.1).

[29] The emission current was set for each gas in order to achieve a reasonable average ion count rate (see Table 2). The voltage of the SEM was set to be at 2600 V, which is slightly above the “knee” (i.e., beginning of the plateau) in the curve of voltage versus count rate. This is the optimum operating voltage because all of the signal is being collected at the SEM input. The source cage is kept at 2V, the focus slit is at -90V , and the electron energy is at 70V.

[30] All processes are automated in order to achieve reproducible, “around-the-clock” measurements using Visual Basic programs. Under normal conditions, two sets of eight samples can be loaded onto the automanifold and then the system can operate completely independently for approximately 5 days (or longer if only gas standards are being analyzed). Monitoring of all components and changes to the programs can be done remotely (i.e., from the internet).

2.5. Standardization

[31] For a standard for both the noble gas abundances and the helium and other isotope ratios, we use aliquots of a sample of marine air that was collected in a 15 liter helium leak-tested, valved, metal vessel that was initially evacuated in the laboratory to a pressure of better than 1×10^{-7} torr. The vessel was brought to the beach on Vineyard Sound, Massachusetts, outside of Woods Hole Oceanographic Institution, equilibrated with ambient conditions for 1 h, and filled with air by opening the valve for 2 min, with the temperature,

relative humidity, and barometric pressure being recorded.

[32] The aliquot volumes on the processing line are chosen such that the amount of He and Ne in the air standard approximates the He and Ne contents of water samples. However, because of differences in solubilities of the noble gases, the amounts of Ar, Kr and Xe in a water sample differ from those in an air standard by roughly a factor of 2, 4, and 7, respectively. Thus, we created an additional “makeup” standard, a standard consisting of purchased, purified Ar, Kr, and Xe in an amount such that the size of one aliquot of makeup standard plus one aliquot of the air standard would result in Ar, Kr, and Xe concentrations roughly similar to that of a warm water sample. By using two aliquots of the makeup standard and one aliquot of the regular air standard, we have similar gas concentrations and ratios as in a cold water sample.

[33] We made the makeup standard by expanding aliquots of pure Xe, Kr, and then Ar (in that order) at a known pressure, volume, and temperature into a leak-tight, volume-calibrated 15 L standard tank that had previously been evacuated. The pressure was measured with a capacitance manometer to within 0.1 torr (MKS baratron controller, model 270B-4 with model 390HA 100 torr absolute pressure transducer). The Ar was ultra-high-purity Ar, 99.999% purity, from CorpBrothers. The Kr and Xe were research grade gases, 99.999% purity, from SpectraGas. We then calibrated the makeup standard for Ar, Kr, and Xe to better than 0.1% by running one aliquot of makeup standard and analytically comparing it to runs of two, four, or seven aliquots of the air standard. We ran multiple aliquots of air standards so as to match the size between the makeup and air standards as closely as possible to mitigate linearity effects. In addition, since the amount of Ar and Xe in the sample affects the amount of Kr released from the trap (see section 4.2), we used extra aliquots of pure Ar and Xe when calibrating for Kr to minimize the error in the correction for this matrix effect.

[34] Each time a standard is run, the remaining amount of gas in the standard tank is depleted by approximately 5×10^{-4} to $5 \times 10^{-3}\%$, depending on the size of the aliquot of standard removed and the volume of the tank. This depletion factor is taken into account when calculating results. In order to calculate linearity effects associated with larger or smaller gas sizes, we have two aliquot volumes connected to the air standard sample, one being 10% the size of the other.

Table 3. Performance of the QMS for Measuring the Major Isotopes of the Five Noble Gases

	⁴ He	²⁰ Ne	⁴⁰ Ar	⁸⁴ Kr	¹³² Xe
Gas in a standard (cm ³ STP)	4.0×10^{-6}	1.3×10^{-5}	1.9×10^{-2}	2.3×10^{-6}	1.5×10^{-7}
Signal on QMS (cps)	1.1×10^5	2.7×10^5	1.2×10^5	1.7×10^5	1.8×10^5
Precision (%)	0.10	0.14	0.10	0.14	0.17
Blank (as % of standard)	0.004	0.01	0.07	0.0004	0.004
Isotopic ratios measured	–	²² Ne/ ²⁰ Ne	⁴⁰ Ar/ ³⁶ Ar	⁸⁶ Kr/ ⁸⁴ Kr, ⁸⁴ Kr/ ⁸² Kr	¹³² Xe/ ¹²⁹ Xe, ¹³⁶ Xe/ ¹³² Xe
Precision (‰)	–	1.9	13	2.0, 2.5	0.9, 1.3
Isotopic ratio in air	–	0.102	293	0.304, 4.91	1.02, 0.331
Isotopic Ratio from QMS	–	0.098	271	0.291, 4.95	1.06, 0.327

[35] The running standard is calibrated against a reference air standard, an air standard collected in the same way but only run occasionally in order to assess if leaks or other problems have developed with the running standard. The air standards and reference air standards typically agree within 0.2% and multiple reference air standards are calibrated against a running standard to decrease the error further to less than 0.1%.

3. Analytical Performance and Reproducibility

3.1. Performance of the System

[36] By using both a charcoal and a stainless steel cryotrap, we can separate the noble gases, such that for a measurement at a given release temperature, the gas sample within the mass spectrometer is predominantly composed of only a single noble gas. Helium is released on a separate trap (the ACC) from the other gases. The release curves for the gases from the SSC are similar to the ones that have been published previously [Lott, 2001]. Virtually quantitative separation is obtained for Ne and Ar. For Ar, Kr, and Xe, however, the release curves overlap, making separation more difficult. Hence Ar and Kr have to be released below the temperature at which 100% of the gas is released. In essence, the trade-off is between less quantitative release (and hence potentially greater temperature dependence and variability) versus potential systematic effects associated with commingling gases in the mass spectrometer. The gases are more vulnerable to being inadvertently removed from the cryotrap when they are being pumped than when they are being volumetrically expanded. Thus, Kr is expanded into a constant fixed volume for analysis at 103 K, and then the excess Kr in the trap is pumped away at a lower temperature (93 K) in order to minimize Xe loss. Experiments indicat-

ed that as much as 5% of the Xe would be lost were the trap pumped at 103 K.

[37] In the He, Ne, and Ar QMS analyses, no other noble gases were detectable. In the Kr analysis, an amount of Ar equal to 20% of the Kr signal was detectable. In the Xe inlet, small amounts of Ar and Kr were detectable (0.3% and 10% of the Xe signal, respectively). Such small amounts of other noble gases do not appear to interfere with the measurements of the primary noble gas.

[38] When measuring ²⁰Ne and ²²Ne, one needs to also consider any contribution from doubly charged ⁴⁰Ar (at mass 20) or CO₂ (at mass 22), as such species are not resolved from ²⁰Ne and ²²Ne. Measurements of Ne-free samples indicate that 10% of the ⁴⁰Ar and 1% of the ⁴⁴CO₂ is doubly charged, which implies that Ar and CO₂ could be contributing to at most 0.004% and 0.05% of the ²⁰Ne and ²²Ne signals, respectively. Since Ar and CO₂ are measured during the analysis of Ne, we can make this correction, even though it is not significant compared to the other uncertainties in the measurements.

[39] The isotopic ratios of Ne, Ar, Kr and Xe as measured by the QMS differ from atmospheric ratios (Table 3). The discrimination is not a monotonic function of mass, suggesting the fractionation is not solely due to sample processing, release from the cryotrap or mass discrimination within the electron multiplier. The fractionation generally favors the more abundant isotope. This deviation from the expected isotope ratios may be due to fractionation within the ion source or to the complex ion optics of the three stage quadrupole mass filter. The exact cause of the fractionation does not matter, however, as the discrimination should occur equally in both standards and samples. Thus this bias should largely cancel out by normalizing unknowns to standards; in essence, we rely on calibration and stability of the system.

[40] In order to assess the linearity of the response of the QMS and of the sample/standard processing to the size of the samples, we analyzed standards with sizes varying from 90% to 200% of the typical standard by mixing different sizes and numbers of aliquots from the same gas standard. The response of the QMS to the size of the standards is linear, with linear least squares regression coefficient r^2 values of at least 0.999. The response of the QMS throughout this range confirms that our samples and standards are in the linear dynamic range of the instrument. We used a linear least squares regression to fit the relative count rate between different size standards to the relative amount of gas in the standard, fixing the intercept to be one for the reference standard size. The slopes of He, Ne, Ar, and Xe are within 1% of unity, suggesting a straightforward relationship between count rate and amount of gas in the sample. For He, Ne, Ar, and Xe, the size of the linearity correction ranges from 0.2% to 0.5% with the uncertainty on the correction ranging from 0.007% to 0.1%. The Kr measurements appeared to have a slope significantly different from unity. We discovered that the Kr measurements are affected by the amount of Ar and Xe in the sample (see section 4.2). It is therefore necessary to account for variations in Ar and Xe concentrations when evaluating Kr linearity. A full treatment of the Kr linearity and the Ar and Xe matrix effect on Kr is described in section 4.2.

[41] We examined the drift of the instrument due to factors such as changing room temperature, change in the SEM gain or high voltage, degradation of the filament, changing reactivity of the surface of the traps, etc. by making repeated measurements of the air standard over the course of several days. The standards show a downward drift with time for all gases that could be associated with aging of the filament and ion source or change in gain on the SEM. Because of the downward drift, when measuring samples we alternately measure samples and standards, use a cubic smoothing spline to interpolate the standard measurements to the times when samples were measured, and then use the interpolated standard results to calculate the sample values. The tension of the cubic smoothing spline is chosen so that the spline is in the transitional region between the least squares straight line fit and the variational cubic spline interpolant. We tested this approach by determining the uncertainty associated with using the standards to predict a value for a sample measured between adjacent standards. To do so, we treated half of the standards as “unknowns.” We then fit the cubic smooth-

ing spline (as described above) to the remaining standards to interpolate the response of the system at the time of the “unknowns.” By comparing the predicted value to the actual value, we can calculate the random error in our measurements. The thus computed errors ranged from 0.10% for He to 0.17% for Xe (Table 3).

[42] The peak shapes of ^3He and ^4He in the HIMS are flat-topped. The ^3He peak is separated from hydrogen deuteride (HD), also of nominal mass 3, by a local minimum (“valley”) of about 5%. The background due to ions that have scattered off neutrally charged particles is approximately 1% of the ^3He signal. The $^3\text{He}/^4\text{He}$ ratio measured on air standards is 1.0×10^{-6} , smaller than the atmospheric ratio of 1.4×10^{-6} [Clarke *et al.*, 1976; Hoffman and Nier, 1993]. One possible explanation is that there may be mass discrimination in the ion source. We tuned the source on ^4He because it is larger and less subject to the ion counting variations seen with ^3He and thus perhaps the ^4He ions are extracted out of the ion box more easily than the ^3He ions. Support for this hypothesis comes from the fact that the apparent isotope ratio ($^3\text{He}/^4\text{He}$) increases with time during the analysis. Since we compare standards to samples, however, this discrimination does not result in systematic errors in our calculated He isotope values. The theoretical limit to the precision of the helium isotope measurement is governed by the number of ^3He ions collected (Poisson statistics) and is calculated to be 0.06%. In practice there are other sources of variability and thus the measured reproducibility is slightly greater than that of Poisson statistics, being about 0.07%. Random error from sample collection and processing lead to the difference between duplicate pairs of water samples to be 0.14%.

3.2. Results for Analyses of Water Samples

[43] To assess the accuracy of this method, we prepared eight samples of distilled water equilibrated with air and analyzed them using this method. A temperature-controlled bath (volume = 17 L) was stirred for 5 days with a bellows pump drawing air from outside the laboratory window into the head space above the water through 16 m of copper tubing. The length of the tubing was to ensure that the air reached the temperature of the lab before coming in contact with water. “Outside” air was used rather than laboratory air to ensure that the ratio of the gases were of atmospheric proportions, rather than being affected by any

Table 4. Performance of the QMS for Measuring the Major Isotopes of the Five Noble Gases in Distilled Water Samples Consisting of 90 g of Water Equilibrated With Air

	⁴ He	²⁰ Ne	⁴⁰ Ar	⁸⁴ Kr	¹³² Xe
	<i>Before Correction for Bubble Entrainment</i>				
Mean saturation (%)	103.6	104.3	101.2	100.5	100.4
Standard deviation of saturation (%)	1.1	1.4	0.3	0.4	0.3
	<i>After Correction for Bubble Entrainment</i>				
Mean saturation (%)	99.3	100.8	100.2	99.9	99.8
Standard deviation of saturation (%)	0.2	0.3	0.3	0.4	0.3

possible small leaks from gas cylinders used in the laboratory. The atmospheric pressure and air temperature, as measured in the head space of the bath (i.e., just above the water), as well as the water temperature were recorded continuously. The atmospheric pressure was $766 \text{ torr} \pm 5 \text{ torr}$ (1σ standard deviation), the water temperature was $19.8 \pm 0.03^\circ\text{C}$, and the air temperature was $21.2 \pm 0.2^\circ\text{C}$ during the 5 days.

[44] After 5 days of continuous stirring, samples were drawn into valved stainless steel sample cylinders from a level 2.5 cm above the bottom of the bath through a piece of stainless steel tubing mounted through the bath cover. Roughly half the water was used during sampling. The gases were extracted from the sample cylinders into 30 cm^3 aluminosilicate glass bulbs using the “at-sea extraction system” [Lott and Jenkins, 1998]. The saturation states of the noble gases in the samples were calculated using the freshwater solubility values of Krause and Benson [1989] and are reported in Table 4. There is some uncertainty in this calculation given that the atmospheric pressure was variable during the course of the experiment (standard deviation of atmospheric pressure was 5 torr, or 0.6% of the total pressure) and the gases may not have adjusted immediately to changes in pressure. We mitigated this problem, however, by not sampling immediately after any changes in pressure.

[45] Helium, Ne and Ar may be supersaturated because of bubble entrainment during the sampling procedure. The geometry of the plug valves on the sampling cylinder may be conducive to trapping a small quantity of air. We thus corrected the saturation values by calculating an air entrainment amount separately for each sample such that with this correction, the saturation states for all gases approaches 100%. The mean amount of air entrained in the samples is $0.03 \pm 0.01 \text{ cm}^3$. This air entrainment has the largest affect on the He and Ne saturation states, then on the Ar, and only a

minor effect on Kr and Xe since these latter gases are more soluble. The mean saturation state and standard deviation of the samples after this air entrainment correction are also listed in Table 4. This issue of air entrainment is clearly problematic and work should be done to devise better sampling methods. Nonetheless, it can be corrected for in water samples, to a large extent, by subtracting the typical amount of air entrained as determined from laboratory experiments.

[46] For Ar, Kr, and Xe, the mean saturation states are within one standard deviation of 100% and the standard deviation are 0.3%, 0.4%, and 0.3%, respectively, signifying that this method can accurately and precisely measure the heavier noble gases in water samples. For He and Ne, the saturation state is slightly outside one standard deviation of 100% suggesting that the air entrainment correction may not have properly accounted for the error and there may still be sampling issues with these gases. We think the issues are related to sampling rather than measurement because the standard deviation for air standards is smaller than 0.1% for He and Ne whereas the standard deviation for these water samples before the air entrainment correction is greater than 1%.

[47] The ultimate test of the reproducibility of this method including both sampling and analysis is the difference between replicate pairs of water samples collected from the same Niskin bottle on an oceanographic cruise. The uncertainties of this method for replicate seawater samples are 0.96% for He, 0.88% for Ne, 0.28% for Ar, 0.29% for Kr, and 0.19% for Xe. These are comparable but slightly smaller than the standard deviation of the experimental equilibrated water samples described above. The worse reproducibility of Kr and Xe in the equilibrated water bath samples as compared to the replicate seawater samples may be because the temperature of the water bath changed by 0.1°C while samples were being drawn, affecting Kr and

Xe the most as these gases have the strongest temperature dependence of solubility.

4. Discussion

[48] The method presented here measures all five noble gases from a single sample. Good separation of the noble gases is obtained, even of the heavier noble gases which traditionally have been the most difficult to separate. The results are reproducible and test water samples show reasonable saturation values. In order to achieve these results, we had to resolve several procedural issues. Below we discuss several of the problems that were encountered in developing this method and how we resolved them. Such a discussion may be of use to those who wish to adapt this method for their own analyses.

4.1. Experimental Determination of the Optimal Method for the Separation of the Noble Gases

[49] The multiple cryogenic system offers a powerful method for separating the noble gases. Although the principle of the noble gases being released at different temperatures is simple, the actual separation does not necessarily happen in a straightforward fashion. On a charcoal cryotrap, the release curves for the heavier noble gases overlap significantly, with one gas starting to be released long before the previous gas is 100% released. Additionally, on a charcoal trap, the heavier gases are released at very high temperatures (280 K for Ar, for example), requiring very long cycle times for warming and cooling the trap. Helium must be trapped on a charcoal cryotrap because it will not sorb to a stainless steel cryotrap at easily achievable temperatures (i.e., >8 K). However, the other noble gases are more effectively analyzed by trapping with a stainless steel cryotrap, as the release curves are a sharper function of temperature and the release temperatures are lower (only 60 K for Ar, for example). Nonetheless, some small overlap of release curves occurs [Lott, 2001]. Furthermore, Ar is orders of magnitude more abundant than Kr or Xe in air and consequently in water, making it especially important to remove all Ar before analyzing Kr or Xe fractions.

[50] In order to achieve the best separation of the noble gases, we examined a range of release temperatures and procedures. In general, the cryotrap was operated at its minimum temperature (~8 K) while drawing gases onto it. The temperature is

raised to successively higher temperatures to release each noble gas separately. Sometimes it was necessary to compromise on a release temperature, releasing a gas at a temperature below which 100% of the gas was released in order to prevent releasing too much of the following gas. For example, we found it necessary to release Ar at 60 K, even though only approximately 80% of Ar is released at this temperature, in order to prevent Kr from being released with the Ar. Since sample results are compared to standards, the exact amount of the gas released does not matter, as long as the same percentage is released in every analysis. Nonetheless, the advantage of being near the 100% release point is that then small fluctuations in the temperature of the cryotrap do not have a large effect on the amount of gas released.

[51] At the optimal release temperatures for Kr and Xe, we found that large amounts of Ar were being let in with the Kr and Xe subsamples. Increasing the pumping time at the Ar release temperature did not significantly reduce the amount of Ar being inlet with Kr and Xe. We successfully reduced the Ar in the Kr and Xe inlets by one to two orders of magnitude by isolating the SSC, warming, cooling, and pumping on the SSC after the Ar inlet and before starting the Kr inlet. We hypothesize that some Ar may be initially cryotrapped by the Kr and Xe atoms in the SSC. By warming the SSC to 150 K, all the Ar, Kr, and Xe atoms are converted to the gaseous phase. Then when the SSC is slowly cooled to 62 K, the Kr and Xe recondense but most of the Ar remains in gaseous phase. Pumping on the trap at 62 K removes the Ar. We found that including this heating/pumping cycle was necessary to reduce the Ar to less than 20% of the Kr signal and to less than 1% of the Xe signal.

[52] Similarly, in order to achieve minimal Kr in the Xe inlet, we added an additional heating/pumping cycle immediately after the Kr analysis. Again we theorize that by warming the trap, we convert the Kr and Xe to gaseous phase, allowing any Kr cryotrapped by Xe to be freed. Then after the trap is cooled, Kr is still in the gaseous form and is pumped away. By warming the SSC to 155 K, cooling it to 93K, and pumping, we were able to reduce the Kr in the Xe inlet by an order of magnitude so that the Kr accounted for less than 10% of the Xe signal.

4.2. Matrix Effects of Ar and Xe on Kr

[53] We observed a “matrix” effect with the SSC in which samples with larger amounts of Ar resulted in

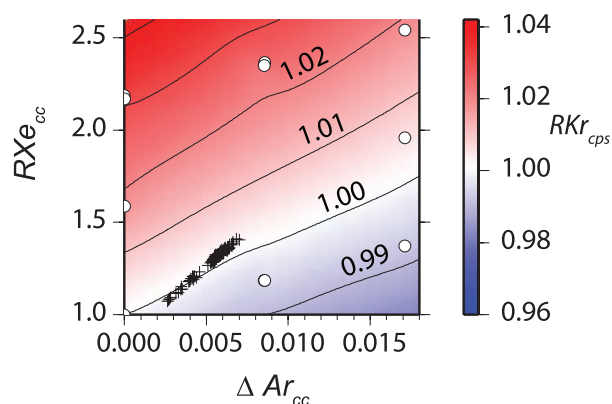

Figure 6. Contour plot of the “matrix effect” of Ar and Xe on the Kr measurements. The Kr count rate relative to a standard run with the typical ratio of Ar/Kr/Xe is plotted versus the absolute amount of additional Ar (in std cc) added to the standard (ΔAr_{cc}) and the relative amount of additional Xe (RXe_{cc}). All the standards run in the experiments plotted here had identical amounts of Kr. However, when more Ar (or less Xe) was added, the apparent Kr ion count rate decreased. Contour lines are drawn at 1% intervals. White circles reflect the data points from the experiments. Black crosses show the expected position of seawater samples with respect to a typical running standard composed of air and the makeup standard. We used the data here as well as additional experiments with pure Ar, pure Kr, and pure Xe standards in order to determine a regression that can correct for these matrix effects. Kr is the only gas that is affected by a change in Ar or Xe concentrations.

smaller Kr measurements. We hypothesize that this effect occurs because the Ar forms a sorption layer or “ice” at low temperatures that is many layers deep on the trap. A simple calculation using the area of the trap and the diameter of an Ar atom results in an estimate of order 100 layers of Ar atoms on the trap surface. It is likely that Kr atoms may be occluded in these layers of Ar. When the Ar is released from the trap at 60 K, some Kr is released with it and swept from the trap during head space expansion of the Ar and pump-out. This leads to a bias where the apparent Kr composition will appear slightly smaller for a sample with a larger Ar/Kr ratio. We detected no similar effect of Ar on Xe, probably because Xe has a much higher release temperature and thus is pulled onto the trap surface at a much higher temperature after the thermal cycling, and hence is layered onto the surface below the Ar layers. Krypton’s vulnerability is that it is more similar to Ar in its sorption characteristics and therefore more likely commingles with it.

[54] Additionally, there is a second matrix effect on Kr due to Xe. If more Xe is in a sample, then more

Kr is released from the trap during the Kr expansion and measurement step. One possible explanation is that Xe can cryotrap some Kr, preventing the Kr from being removed when Ar is released at 60 K. A second possibility is that the Xe atoms may passivate the stainless steel trap, allowing Kr to be more easily released at the Kr release temperature. In either case, this effect needs to be accounted for.

[55] Initially the matrix effects were approximately 1% or 2% but after changes in our procedure, we were able to reduce them to <0.5%. Although we were not able to completely eliminate these matrix effects, we were able to calibrate them precisely (Figure 6) and thus to correct for them within 0.2%. We calibrated these matrix effects by preparing three additional standards composed of pure Ar, pure Kr, and pure Xe. We then ran a number of gas standards with different numbers of additional aliquots of pure Ar, pure Kr, and pure Xe. We performed a multiple nonlinear regression to account for the Ar and Xe effects on the Kr measurements and other Kr “linearity” effects at the same time. We examined a number of functional forms for the correction and found that the form that gave the best fit to the data was

$$RKr_{cps} = 1 + a_1(RKr_{cc} - 1) - a_2\Delta Ar_{cc} \cdot RKr_{cc} + a_3 \cdot (RXe_{cc} - 1) \quad (2)$$

where a_1 , a_2 , a_3 are constants, $RKr_{cps} = Kr_{cps,smpl}/Kr_{cps,std}$, $RKr_{cc} = Kr_{cc,smpl}/Kr_{cc,std}$, $RXe_{cc} = Xe_{cc,smpl}/Xe_{cc,std}$, and $\Delta Ar_{cc} = Ar_{cc,smpl} - Ar_{cc,std}$, with *cc* referring to amount of gas in cm^3 STP, and *cps* referring to the ion count rate measured by the QMS in cps. A nonlinear least squares technique was used to determine the optimal coefficients and their uncertainties (Table 5). When equation (2) was applied to the gas standard experiments, the amount of Kr (in cc STP) calculated matched the known amount to within 0.1% in most cases, and to 0.2% if the amount of Ar or Xe differed by more than 50%

Table 5. Coefficients and Their Uncertainties for the Matrix Effect of Ar and Xe on Kr^a

	a_1	a_2	a_3
Reference is 1 MU	1.069 ± 0.002	1.253 ± 0.09	0.0291 ± 0.002
Reference is 2 MU	1.045 ± 0.002	1.251 ± 0.04	0.0251 ± 0.001

^a Coefficients and uncertainties (1σ) are given with respect to a reference standard composed of 1 aliquot of makeup (1 MU) gas standard and with respect to a reference standard composed of 2 aliquots of makeup gas standard (2 MU).

from the regular standard. The errors in the coefficients and in the measurements were propagated to show that for a 35% deviation in size between standard and sample, the Kr correction would yield a 0.14% uncertainty.

[56] Whereas warm water samples have relative gas ratios similar to that of a running standard consisting of the air standard and one aliquot of makeup standard, cold ($<15^{\circ}\text{C}$) water samples have relative gas ratios similar to that of a running standard consisting of air and two aliquots of makeup standard. We thus performed similar experiments where we added additional aliquots of pure Kr, pure Ar, and pure Xe to two aliquots of the makeup standard. These coefficients are very similar to those determined with a reference to one aliquot of makeup standard, giving confidence in the functional form of equation (2).

4.3. Hydrogen

[57] To help achieve our goal of having primarily one gas at a time in the mass spectrometer, we needed to prevent the often abundant gases such as H_2O , N_2 , O_2 , CH_4 , and H_2 from being inlet into the QMS. Our initial getter system reduced the amount of H_2O , O_2 , and N_2 to acceptable levels but did not suffice for H_2 or CH_4 . There was a large background of H_2 in the QMS, with the H_2 being released from the stainless steel surfaces in the QMS and processing line or by the actuating valves. In order to reduce H_2 , we added a room temperature Fe-Zr-V getter (SAES ST707) to the QMS chamber. Once the sample was inlet, this additional getter sorbed any H_2 within the first few seconds of analysis, reducing the H_2 by two orders of magnitude. This getter also reduced N_2 by one order of magnitude so that N_2 count rate was 1% to 3% of the noble gas count rate.

4.4. Methane

[58] The presence of gases other than the noble ones and hydrogen on the cryotrap can change the release characteristics of the noble gases from the SSC. Our original experimentation with another similarly designed mass spectrometer showed that when CH_4 was drawn onto the SSC, it effectively “activated” the trap surface, which retarded the release of Kr. This is an important potential systematic bias because water samples have approximately a factor of four higher concentration of CH_4 than our air standards and thus we observed that our water samples were yielding erroneously low Kr measurements. Moreover, we were concerned

that an excessive amount of CH_4 , which was released from the SSC at temperatures above 100 K, consequently accompanied the Kr and Xe into the QMS, possibly influencing subsequent measurements.

[59] With the aim of reducing CH_4 , we examined the effect of raising the temperature of the hot half of the flow-through getter. At elevated temperatures ($>300^{\circ}\text{C}$), the getter is supposed to crack methane into C and H_2 . By raising the temperature from 270°C to 310°C , we decreased the CH_4 by 50%. By further increasing the temperature to 350°C , we made only a modest reduction in the CH_4 , but more importantly prevented CH_4 from gradually increasing over time. Additionally, after drawing the sample onto the cryotrap, we raised the temperature of the cool side of the flow-through getter to 350°C and then cooled it again. This temperature cycling resulted in cracking any CH_4 that remained in the cool part of the flow-through getter and thus prevented the CH_4 from accumulating over time. Even with these improvements, however, we still had more CH_4 in our water samples than in our standards.

[60] We thus introduced a Pd catalyst (0.47% Pd on Al Oxide, BASF R0-20/47) into our sample processing system to act on the gas sample prior to getting. Pd and Pt catalysts on alumina, silica, zirconia, and anatase have been used in the catalytic converter industry to oxidize volatile organic compounds (VOC) including methane [Lyubovskiy and Pfeifferle, 1998; Janby et al., 2003; Escandon et al., 2005]. When the catalyst is at temperatures greater than 450°C , Pd catalyzes the oxidation of CH_4 into CO_2 and H_2O . In our system, the catalyst must be placed before the getters since oxygen is necessary for the oxidation reaction to occur and the getters can then remove the CO_2 and H_2O that are products of the oxidation reaction. Additionally, the catalyst must be placed after the WVC in order for the WVC to protect the catalyst from being exposed to large amounts of water vapor.

[61] After the addition of the catalyst, the amount of CH_4 measured in a water sample was equal to the amount measured in an air standard, both being approximately 20,000 cps. Half of this CH_4 comes from the processing line and the other half comes from the QMS itself, perhaps produced by reactions of CO_2 and the H_2 in the stainless steel. Nonetheless, since the amount of CH_4 is the same for both standards and samples, if it interferes with our measurements of the noble gases, it would do

Table 6. Sources of Errors in the Measurements of the Noble Gases^a

Source of Error	⁴ He	²⁰ Ne	⁴⁰ Ar	⁸⁴ Kr	¹³² Xe
<i>Air Standards</i>					
Repeated measurements of standards (%)	0.10	0.14	0.10	0.14	0.17
Intrinsic error sources					
Extrapolation to end of inlet (%)	0.05	0.10	0.06	0.07	0.06
Counting statistics (%)	0.02	0.05	0.03	0.03	0.02
Air standard calculation ^b (%)	0.1	0.1	0.1	0.1	0.1
Contribution from temperature (%)	0.04	0.04	0.04	0.04	0.04
Contribution from relative humidity (%)	0.01	0.01	0.01	0.01	0.01
Contribution from pressure (%)	0.001	0.001	0.001	0.001	0.001
Contribution from aliquot volumes (%)	0.09	0.09	0.09	0.09	0.09
Contribution from interstitial loss (%)	0.002	0.002	0.002	0.002	0.002
Contribution from makeup Std (%)	0	0	0.1	0.13	0.13
Total error for standards (%)	0.14	0.17	0.14	0.17	0.20
<i>Water Samples</i>					
Correction for linearity ^c (%)	0.007	0.1	0.03	–	0.02
Correction for matrix effects on Kr (%)	0	0	0	0.19	0
Correction for extraction efficiency (%)	0.02	0.01	0.04	0.05	0.11
Correction for gas left in bulb (%)	0.01	0.01	0.03	0.03	0.06
Extrapolation to end of inlet (%)	0.05	0.10	0.06	0.07	0.06
Counting statistics (%)	0.02	0.05	0.03	0.03	0.02
Total estimated error for samples (%)	0.15	0.23	0.17	0.27	0.24
Observed error for duplicate water samples (%)	0.96	0.88	0.28	0.29	0.19

^aErrors are listed as 1s values where applicable.

^bThe “air standard calculation” is the sum of the errors from the individual sources in calculating the amount of gas in the air standard.

^cThe linearity uncertainty for Kr is folded into the correction for matrix effects and thus is not listed separately.

so the same way for both standards and samples and thus would have no net effect on our analyses.

4.5. Error Analysis

[62] The total error in the measurement of the noble gases in a sample derives from three main sources. One source is the random and systematic errors associated with the mass spectrometers and processing line when measuring a sample or standard. The second source is the systematic error associated with how well we can calculate the amount of gas in a standard aliquot. The third source is the random or systematic errors introduced in the sample collection and initial extraction of the gases from the water samples. These sources of error and their estimated sizes for the five noble gases as measured on the QMS are listed in Table 6.

[63] We described in section 3.1 how we estimated the random error associated with the processing of a standard; we list this error in Table 6 as “repeated measurements of standards.” This error inherently includes the contribution of two sources of “intrinsic” error due to the QMS measurements: (1) Poisson counting statistics and (2) extrapolation back to inlet. The fact that we are extrapolating

back to inlet introduces an error of about 1.5 to 2 times the intrinsic Poisson uncertainty. The extrapolation reduces dependence on any subsequent fractionation or modification within the QMS during analysis. These intrinsic sources of QMS error are smaller than the total processing line error (error estimated from repeated standards), suggesting that much of the variability comes from sample processing rather than from the QMS itself.

[64] In this method, we calculate the amount of gas in a sample by comparing the ion count measured by the QMS of the sample to the ion count measured by the QMS of an air standard. Thus it is necessary to accurately and precisely calculate how much gas is in an aliquot of air standard. Any error in the calculation of the air standard would lead to a systematic error that would shift all our results. The uncertainties in the calculation of gas in an air standard include the uncertainties in recording the atmospheric conditions (temperature, pressure, relative humidity) when the air standard was collected and the uncertainties associated with determining the volumes of the aliquots and standard cans (Table 6). In order to minimize the uncertainties in the collection of the air standard, we take several “reference” air standards over the

course of months that we compare to our running air standard as described above in section 2.5.

[65] When measuring water samples, there are potential additional sources of systematic biases due to the differences in the size and composition between our water samples and our air standards. Although the response of the QMS is close to linear, the slope of the linearity calculation has some uncertainty. We could decrease this uncertainty by more determinations of the linearity correction. Additionally, we correct for the effect of Ar and Xe on the Kr measurements and this correction leads to some additional error for our Kr measurements. Finally, when running water samples, some of the gas is left in the water in the bulb. We correct for this using the weight of the water (measured after each sample has been run) but uncertainties in the weight of the water, in the temperature of the headspace expansion, and in the ratio of the theoretical to observed amount of gas left behind lead to additional uncertainties for water samples. A combination of all the above effects (including the error from the standards since the standards are used to estimate the size of the samples) yields an error estimate for our samples, which is listed as estimated error in Table 6.

[66] There is also a source of error associated with the sample collection and initial extraction of the gases. For example, bubbles can stick to the walls of the sample chamber or lurk in the internal geometry of the plug valves on the sample cylinders and thus erroneously increase the He and Ne concentrations. Furthermore, although we did experiments to confirm that the gases are usually quantitatively extracted from the seawater samples into the aluminosilicate bulbs, if the temperature during the extraction is too low, occasionally all the gases may not be extracted from the samples. Thus it is not surprising that the uncertainties as determined by duplicate pairs of water samples are typically larger than the uncertainties of the gas standards. The best estimate of the random component of our total measurement and sampling error comes from duplicate samples. The errors for the duplicates are the highest for He and for Ne, suggesting we may be entraining bubbles during sample collection.

5. Conclusions

[67] We present here a method for measuring all five noble gases from a single water sample. New features of this method include the incorporation of

an automated, programmed stainless steel cryogenic trap into the processing line of a QMS, as well as the inclusion of a two-stage automated, programmed water vapor trap and a Pd catalyst. By repeatedly warming, cooling and pumping the stainless steel cryotrap, we separate the heavier noble gases, resulting in improved precision. The precision for this method for air standards for He, Ne, Ar, Kr, and Xe is very good and will allow the noble gases to be used for geochemical estimates of processes such as gas exchange. The method is fully automated and allows measurement of noble gas isotope ratios in approximately 3 h. The method as presented here was used on 90 g water samples but has also been used on smaller 1 g samples and could be adapted for use with rock or ice samples.

[68] The variability in our isotope ratios for Xe is smaller than in our absolute abundances, suggesting that this method for Xe could be even further improved by using isotope dilution. However, the disadvantage of isotope dilution is it precludes measurement of natural isotopic ratios. Additionally, since the error for our water samples is significantly larger than for our standards, the limitation to our measurements at present does not come from the sample processing and analysis but rather from the initial sample collection and preparation. Thus future studies should include investigation on more reproducible ways to collect and extract the gases from seawater.

Acknowledgments

[69] We wish to thank Mark Kurz for use of the stainless steel cryotrap that was used for the initial testing of this method. We thank two anonymous reviewers for their helpful suggestions. We are grateful for support by the National Science Foundation Chemical Oceanography program (OCE-0221247), by the Department of Defense (graduate fellowship to RHRS), and by the Woods Hole Oceanographic Institution (postdoctoral fellowship for B.B.).

References

- Beyerle, U., W. Aeschbach-Hertig, D. M. Imboden, H. Baur, T. Graf, and R. Kipfer (2000), A mass spectrometric system for the analysis of noble gases and tritium from water samples, *Environ. Sci. Technol.*, *34*(10), 2042–2050.
- Clarke, W. B., W. J. Jenkins, and Z. Top (1976), Determination of tritium by spectrometric measurement of ³He, *Int. J. Appl. Radiat. Isotopes*, *27*, 515–522.
- Escandon, L. S., S. Ordonez, A. Vega, and F. V. Diez (2005), Oxidation of methane over palladium catalysts: Effect of the support, *Chemosphere*, *58*(1), 9–17.
- Hamme, R. C., and S. R. Emerson (2004), Measurement of dissolved neon by isotope dilution using a quadrupole mass spectrometer, *Mar. Chem.*, *91*(1–4), 53–64.

- Hoffman, J., and A. Nier (1993), Atmospheric helium isotopic ratio, *Geophys. Res. Lett.*, *20*, 121–123.
- Janby, A., W. Clark, E. Noordally, S. Grimses, and S. Tahir (2003), Noble metal catalysts for methane removal, *Chemosphere*, *52*, 1041–1046.
- Krause, D., and B. Benson (1989), The solubility and isotopic fractionation of gases in dilute aqueous-solution: 2a. Solubilities of the noble gases, *J. Solution Chem.*, *18*, 823–872.
- Kulongoski, J. T., and D. R. Hilton (2002), A quadrupole-based mass spectrometric system for the determination of noble gas abundances in fluids, *Geochem. Geophys. Geosyst.*, *3*(6), 1032, doi:10.1029/2001GC000267.
- Lott, D. E., III (2001), Improvements in noble gas separation methodology: A nude cryogenic trap, *Geochem. Geophys. Geosyst.*, *2*(12), 1068, doi:10.1029/2001GC000202.
- Lott, D., and W. J. Jenkins (1984), An automated cryogenic charcoal trap system for helium isotope mass spectrometry, *Rev. Sci. Instrum.*, *55*, 1982–1988.
- Lott, D., and W. J. Jenkins (1998), Advances in analysis and shipboard processing of tritium and helium samples, *Int. WOCE Newsl.*, *30*, 27–30.
- Lyubovskiy, M., and L. Pfefferle (1998), Methane combustion over the alpha-alumina supported Pd catalyst: Activity of the mixed Pd/PdO state, *Appl. Catalysis A*, *173*, 107–119.
- Poole, J. C., G. W. McNeill, S. R. Langman, and F. Dennis (1997), Analysis of noble gases in water using a quadrupole mass spectrometer in static mode, *Appl. Geochem.*, *12*(6), 707–714.
- Sano, Y., and N. Takahata (2005), Measurement of noble gas solubility in seawater using a quadrupole mass spectrometer, *J. Oceanogr.*, *61*(3), 465–473.