

WHOI-87-8

DEEP SEA MOORINGS FISHBITE HANDBOOK

by

H.O. Berteaux

and

Bryce Prindle

WOODS HOLE OCEANOGRAPHIC INSTITUTION
Woods Hole, Massachusetts 02543

March 1987

TECHNICAL REPORT

Prepared for the Office of Naval Research
under contract No. N00014-84-C-0134, NR 083-400.

Reproduction in whole or in part is permitted for any purpose of the
United States Government. This report should be cited as:
Woods Hole Oceanogr. Inst. Tech. Rept. WHOI-87-8.

Approved for public release; distribution unlimited.

Approved for Distribution: _____



Dr. Robert C. Spindel, Chairman
Department of Ocean Engineering

ABSTRACT

The purpose of this handbook is to bring awareness and a degree of expertise to the very real problem of fish attacks on mooring lines and cables deployed in the open seas.

Over the years the authors have carefully examined a large sample of damaged, sometimes entirely severed ropes retrieved from the sea.

Often direct evidence and / or biological observations showed that the ropes were the victims of fish attacks. In many cases however the cause of rope failure remained difficult to ascertain. Techniques and rationales therefore had to be devised to elucidate the more thorny cases.

Understanding a problem, the saying goes, is half of the solution. The other half, as far as this handbook is concerned, is of course to make known the ways which, at the moment, could help prevent fishbite attacks or at least abate its effects.

Thus the handbook will follow a natural progression. A short introduction retraces the early suspicions which soon translated into confirmed fish attacks. The next two chapters cover the recognition and the extent of the fishbite problem in great depth.

Chapter 2 presents in meticulous details the techniques which can be used to determine how a rope was damaged while in service, either by fishbite or any other plausible cause. The analysis of a data base which spans over twenty years and encompasses close to a thousand moorings is presented in Chapter 3: Dimensions of the fishbite problem. This chapter provides valuable information for use in estimating fishbite hazard.

Who are the culprits and why they do it is reviewed in Chapter 4: Biting organisms and predisposing factors. This chapter identifies the marine organisms which have significant biting capabilities and outlines some of the environmental factors and processes which incite and result in fishbite damage.

The last chapter: Prevention and control of fishbite damage, reviews the preventive methods used to reduce the incidence or the severity of fish attacks and the curative methods - including up to date techniques for jacketing metallic and non-metallic ropes and cables - which hopefully will protect mooring lines from the mechanical damage inflicted by fish teeth.

ACKNOWLEDGMENTS

Help to write this handbook came in many forms. There were those who provided the problem ... and the data, those who helped devise test procedures and perform the tests, those with the difficult questions and the pertinent remarks, those who believe in our work and funded the project, and of course those who actually put the handbook together.

In particular we want to thank R.G. Walden co-author of the first fishbite manual (1975), Dr. R. Backus, our well known shark expert, the WHOI Buoy Group who dutifully inspected hundreds of miles of cable and noted all (most) of the fishbites, J. Dunoyer who screened the records and produced the histograms, B. Hirschel our resident artist who created all the art work, and of course L. Moore who typed and retyped - thank you 'Word Processor' - the manuscript.

Our gratitude also goes to the National Data Buoy Center (NDBC) who sponsored fishbite research for many years and to Dr. E. Silva of the Office of Naval Research (ONR) who supported and directly sponsored the writing of this handbook.

The work reported herein was done under ONR contract N00014-84-C-0134, NR 083-400.

TABLE OF CONTENTS	PAGE NUMBER
ABSTRACT	i
ACKNOWLEDGMENTS	iii
TABLE OF CONTENTS	v
LIST OF FIGURES	ix
CHAPTER 1 - INTRODUCTION	1
1.1 Purpose of the Handbook.	1
1.2 Historical recognition of the fishbite problem.	1
1.3 Scope of the Handbook.	8
1.4 Fishbite attacks on components other than mooring lines.	10
CHAPTER 2 - DETECTION AND IDENTIFICATION OF FISHBITE DAMAGE	11
2.1 Systematic documentation of damaged mooring components.	11
2.2 Observations made on shipboard at time of recovery.	13
2.2.1 Plastic covered lines.	13
2.2.2 Unjacketed synthetic fiber lines.	13
2.3 Laboratory study.	13
2.3.1 Confirmation of shipboard observations.	13
2.3.2 Examination of plastic jacketed lines.	14
2.3.3 Identification of fishbite in unjacketed fiber lines.	18
2.3.3.1 Sample preparation.	20
2.3.3.2 Microscopic examination.	23
2.3.3.3 Standards of comparison.	26
2.3.3.4 Interpretation of results.	86
2.4 Conclusion.	92
CHAPTER 3 - DIMENSION OF THE FISHBITE PROBLEM	93
3.1 Study of fishbites on a large sample of oceanic moorings.	93
3.1.1 Procedure for establishing fishbite data.	93

TABLE OF CONTENTS CONTINUED	PAGE NUMBER
3.1.2 Ocean areas included in the study.	94
3.1.3 Yearly variations in fishbite attack.	97
3.1.4 Fishbite vs. conditions of deployment.	99
3.1.4.1 Fishbite vs. buoy depth.	99
3.1.4.2 Fishbite vs. geographical location.	101
3.1.4.3 Fishbite vs. bottom depth.	103
3.1.4.4 Fishbite vs. duration of moored station.	104
3.1.4.5 Fishbite vs. depth of occurrence at a single location.	107
3.1.4.6 Fishbite vs. depth of occurrence worldwide.	112
3.1 5 Conclusions.	114
3.2 World wide distribution of fishbites.	114
CHAPTER 4 - BITING ORGANISMS AND PREDISPOSING FACTORS	118
4.1 The pelagic environment.	118
4.2 Moorings as centers of biological activity.	123
4.3 Marine organisms with significant biting capabilities.	124
4.3.1 Mollusca.	124
4.3.2 Chondrichthyans (Cartilage fish).	125
4.3.3 Osteichthyans (Bony fish).	127
4.3.4 Sea turtles.	134
4.4 Environmental factors and fishbite.	135
4.4.1 Getting together.	135
4.4.2 Attraction and attack stimuli.	137
4.4.2.1 Chemical attractants.	137
4.4.2.2 Audio-mechanical signals.	137
4.4.2.3 Visual stimuli.	140
4.4.2.4 Electromagnetic fields.	142
4.4.2.5 Temperature.	143
CHAPTER 5 - METHODS AND CONTROL OF FISHBITE DAMAGE	145
5.1 Preventive methods.	145
5.1.1 Operational limits.	145
5.1.2 Reducing factors of attraction.	147
5.2 Curative methods.	149
5.2.1 Use of metallic ropes.	149
5.2.2 Use of large diameter syntactic fiber ropes.	150

TABLE OF CONTENTS CONTINUED	PAGE NUMBER
5.2.3 Protecting non-metallic ropes.	152
5.2.3.1 Early attempts.	152
5.2.3.2 Fishbite process.	153
5.2.3.3 Armor material test and evaluation procedure.	154
5.2.3.4 Physical and mechanical properties required for armoring materials.	162
5.2.3.5 Candidate armor materials and techniques.	167
5.2.3.6 Procedures for testing fishbite armors at sea.	172
APPENDIX A	175
REFERENCES	177

LIST OF FIGURES	PAGE NUMBER
1.1 Typical fishbite on 5/16" diameter polypropylene rope	2
1.2 1/2" Nylon rope damaged by fishbite	3
1.3 Fishbite on plastic jacket of steel wire rope	4
1.4 Typical scratch in plastic jacket of steel mooring line	4
1.5 Tooth cuts in plastic jacket of towed acoustical array	6
1.6 Paired cuts in a polyvinyl chloride sheath on polypropylene rope	7
1.7 Shark attack on current meter set 20 meters below the surface (1986 - 27 ^o N, 69 ^o 43'W)	9
2.1 Fishbite data sheet	12
2.2 Wire rope termination boot showing numerous fishbite cuts	16
2.3 Shark teeth in heated polyethylene jacket. The black hole resulted from a short circuit	17
2.4 An Xray of the line shown in Fig. 2.3. Reveals the shark teeth <u>in situ</u>	17
2.5 Synthetic fiber rope typical fishbite failure	19
2.6 Parted mooring line (washed and dried)	21
2.7 Representative fiber ends are placed between two layers of scotch tape. The sample is then cut with scissors	21
2.8 Fibers are brushed and mounted on a microscope slide	22
2.9 The sample is covered with glass and ready for examination	22
2.10 Types of failed fiber ends	24
2.11 Simulated fishbite. Nylon rope under tension cut by shark teeth	29

LIST OF FIGURES CONTINUED	PAGE NUMBER
2.12 - 2.35	33-80
2.36 Polyester. Percentage distribution of fiber end appearances as a function of damage causes and sample conditions	82
2.37 Nylon. Percentage distribution of fiber end appearances as a function of damage causes and sample conditions	83
2.38 Polypropylene. Percentage distribution of fiber end appearances as a function of damage causes and sample conditions	84
2.39 Kevlar. Percentage distribution of fiber end appearances as a function of damage causes and sample conditions	85
2.40 Fishbite identification flow chart	91
3.1 Yearly distribution of fishbites from WHOI mooring station logs (1967 - 1985)	98
3.2 Percentage of lines bitten vs. buoy depth	101
3.3 Percentage of lines bitten vs. latitude	103
3.4 Percentage of lines bitten vs. duration	106
3.5 Percentage of lines bitten vs. cumulative duration	108
3.6 Frequency of bites as a function of depth	109
3.7 Number of bites vs. depth (Station #298)	111
3.8 Number of bites vs. depth (Station #300)	111
3.9 Number of fishbites vs. depth (Worldwide)	112
3.10 World geographic distribution of fishbite incidence	116
4.1 The pelagic environment	119
4.2 Jaw of <u>Carcharhinus falciformis</u> (silky shark)	126
4.3 Teeth of <u>Carcharhinus longimanus</u> (white tip shark)	127
4.4 <u>Sudis hyalina</u> (405 mm length)	129

LIST OF FIGURES CONTINUED	PAGE NUMBER
4.5 Lower jaw of <u>Sudis hyalina</u>	130
4.6 <u>Aphanopus carbo</u>	131
4.7 Teeth of <u>Aphanopus carbo</u>	132
4.8 <u>Alepisaurus ferox</u> (lancet fish)	133
4.9 Skull of <u>Alepisaurus ferox</u>	133
5.1 Gulf Stream northern edge superimposed on one another	146
5.2 Wire fracture faces	151
5.3 Mechanics of cutting	155
5.4 The Bitemeter	157
5.5 Armor specimen cutting set up	158
5.6 Durometer D versus stabbing force	161
5.7 Durometer D versus cutting force	161

CHAPTER 1 - INTRODUCTION

1.1. Purpose of the Handbook.

Since 1975 when the "Deep-Sea Lines Fishbite Manual" (Prindle and Walden, 1975) was issued, there have been significant additions to the body of knowledge relative to fishbite damage and its control. It is the purpose of this Handbook to bring information on the subject up to date so that the "state of the art" will be generally available and useful to persons involved in the establishment and maintenance of deep sea moored stations and where lines are used in deep sea water for other purposes. The main focus is on fishbite, but in the course of laboratory investigations, it has been necessary to distinguish between fishbite and other kinds of damage such as tensile overload, cutting with knives, and abrasion. So the laboratory methods described herein can be used to detect those causes of damage as well as fishbite.

1.2. Historical recognition of the fishbite problem.

From the standpoint of biting, there are two types of ropes used in deep sea work. One is an unjacketed rope of synthetic fiber. When used for towing and mooring, this type has many favorable properties, but it is highly susceptible to cutting. A second type is a line made of synthetic fibers, or metal wires which have been covered with a plastic sheath for purposes of insulation, improved ease of handling, or prevention of corrosion. The latter kind of line may fail if its plastic sheath is punctured or stripped off. Both types of lines have been damaged in the marine environment.

Ropes of synthetic fiber have been found severed or cut part way with cuts appearing clean as though made with a keen edge. Figure 1.1 shows the first such cut recorded in the buoy program at the Woods Hole Oceanographic Institution (WHOI) in 1959 (Stimson, 1964). Figure 1.2 shows a nylon rope damaged at a later date. In the latter case, most of the rope cross section was cut through so that the line parted (quite dramatically!) as it was being hauled aboard ship. The parted ends, therefore, show effects of both cutting and tensile break, e.g. truncated ends on the cut yarns and a "ponytail" appearance on yarns broken by tension.

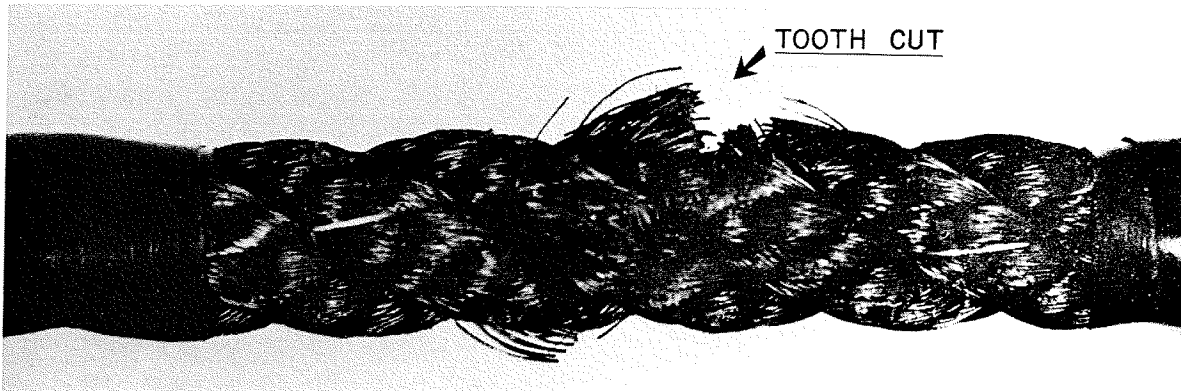

Figure 1.1 Typical fishbite on 5/16" diameter polypropylene rope (Prindle and Walden, 1975).

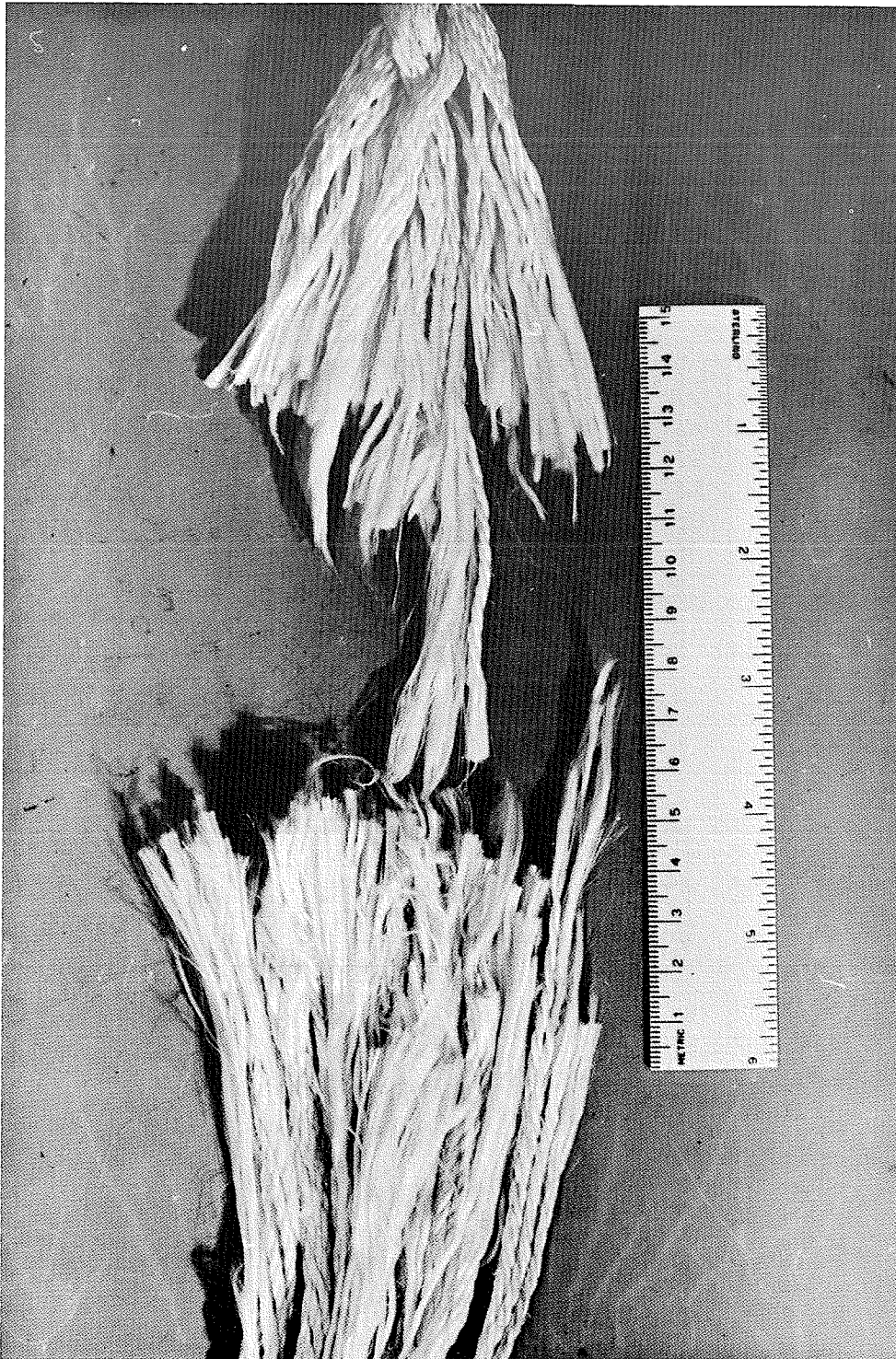

Figure 1.2 1/2" Nylon rope damaged by fishbite (Prindle and Walden, 1975).

Figure 1.3 shows the effect of what is thought to be a biting attack upon plastic sheathing on a metal line. Steel wires within were exposed to the corrosive action of sea water.

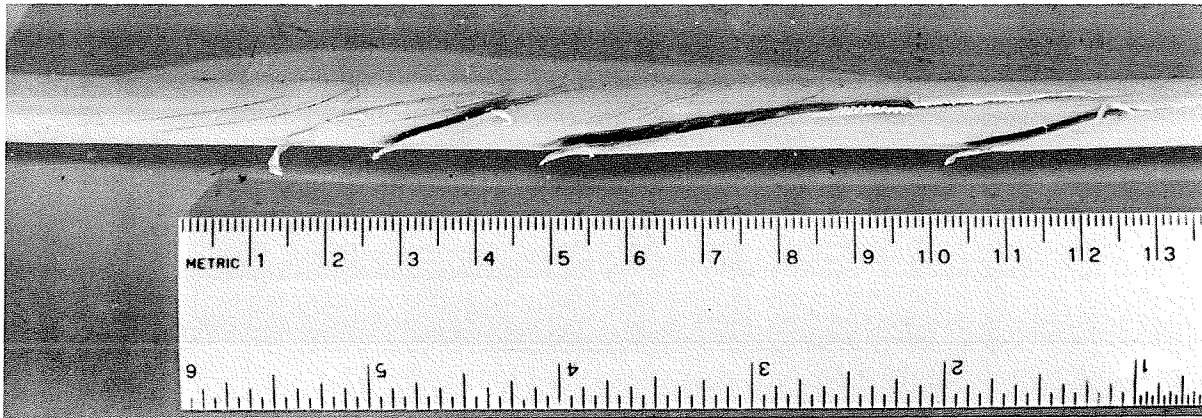

Figure 1.3 Fishbite on plastic jacket of steel wire rope (Prindle and Walden, 1975).

Damage is not always catastrophic. Figure 1.4 shows a steel line covered with high density polyethylene with a long but superficial scratch.

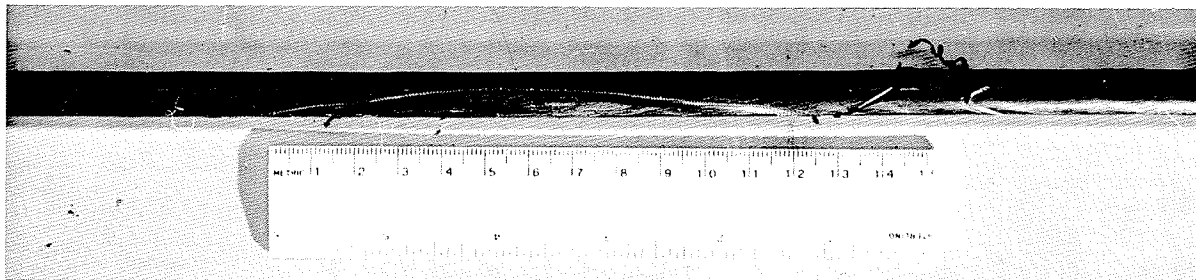

Figure 1.4 Typical scratch in plastic jacket of steel mooring line (Prindle and Walden, 1975).

Most information relative to fishbite has been developed from experience with deep sea mooring lines but there is evidence that other items such as thermistor chains, acoustical arrays, and sonar domes (Gray, 1979) may be attacked. Figure 1.5 is a photograph of a section of a 400 ft.* acoustical array which was towed about 100 miles off the shore of New Jersey. It was noted that 7 or 8 hours before hauling the line a "horrendous" electronic noise occurred. Upon hauling, the cuts shown in Figure 1.5 were seen. They are strongly suggestive of shark bite.

In an attempt to obtain completely documented cases of fishbite as a cause of cuts found on deep sea lines, two experimental moorings were established off the shore of Bermuda (Turner and Prindle, 1965; 1968). The first was set late in the spring of 1964. It consisted of a surface buoy, three 400 meter lengths of 14.3 mm three strand, twisted polypropylene rope encased in a sheath of polyvinyl chloride at the upper end, and sufficient 9/16" diameter plaited nylon rope to reach the bottom. Depth of water at the site, a few miles southeast of Bermuda, was 2000 meters. The purpose was to determine whether the polyvinyl chloride sheath would protect the rope. The line was hauled for inspection after a week.

The second mooring was set in the fall of 1964 near the same spot and consisted of a subsurface buoy submerged approximately 50 meters and moored by a single 2000 meter length of 1 X 19 preformed, galvanized steel strand 3.68 mm in diameter, coated with polyethylene to an outside diameter of 8.13 mm. Wood and asbestos board panels were attached at various intervals to collect fouling and boring organisms. This array was exposed for approximately six weeks and retrieved when a time-release

* See Conversion Table (Appendix A).

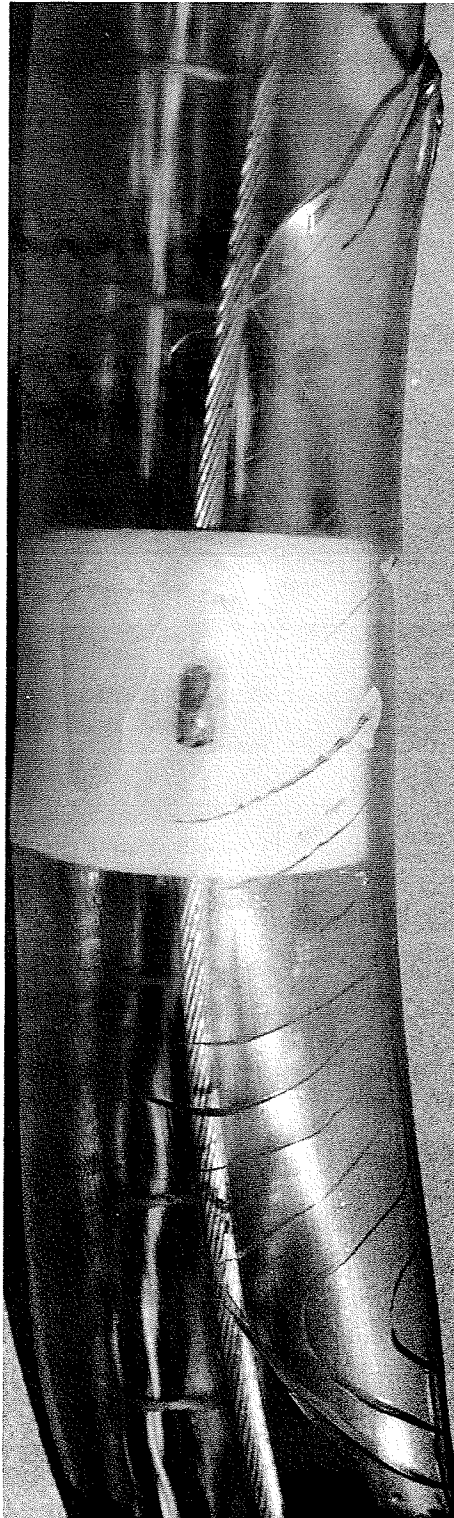

Figure 1.5 Tooth cuts in plastic jacket of towed acoustical array.

recovery package disconnected the mooring line from the anchor.

It was intended to expose the first mooring, which included the rope with the polyvinyl chloride sheath, for a week, remove it for inspection, and then reset it for an endurance test. However, the first inspection revealed so many lacerations that there was serious doubt that it could survive for any great length of time and the endurance test was cancelled.

After a week in the water, the line was found to have more than 40 groups of cuts. Most of them on a section of the line which had been at 400 to 800 meters below the surface of the water. They were clean cuts (Figure 1.6) and were clearly distinguishable from scrapes and other such marks which might have been caused during handling of the line.

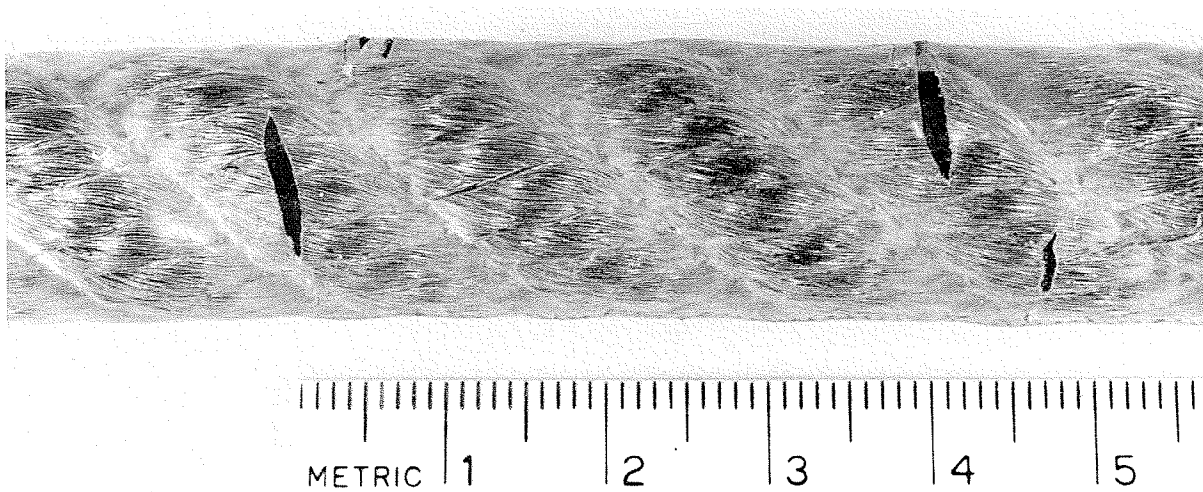

Figure 1.6 Paired cuts in a polyvinyl chloride sheath on polypropylene rope.

Twenty-nine groups of cuts were in pairs. An interesting feature was that cuts occurred on only one side of the line. If indeed, the cuts were a result of biting, the organism must have had teeth on only one jaw.

The separation of cuts which were in pairs varied from 30 to 60 mm. If indeed, as later was found to be the case, they were the result of biting, then a direct measurement of one dimension of the biter, namely jaw width, was on record.

The jacket of the second mooring had many cuts upon retrieval after 40 days in the water. As in the first case, many cuts were paired and only on one side of the line. Tooth points were recovered from both polyethylene line covers and pine panels. The suspicion that lines were being bitten became a fact.

1.3. Scope of the Handbook.

The subject matter of this handbook is intended to give practical information and working methods for the recognition of fishbite damage and its control, as follows:

1. Given a damaged line, how can it be determined whether the damage was due to biting or some other cause?
2. What is the risk of fishbite damage as indicated by experience to date?
3. What deep sea organisms have significant biting capabilities and what factors govern their attacks on moored arrays?
4. What can be done to prevent and/or control fishbite when it is necessary to place lines in high risk areas?

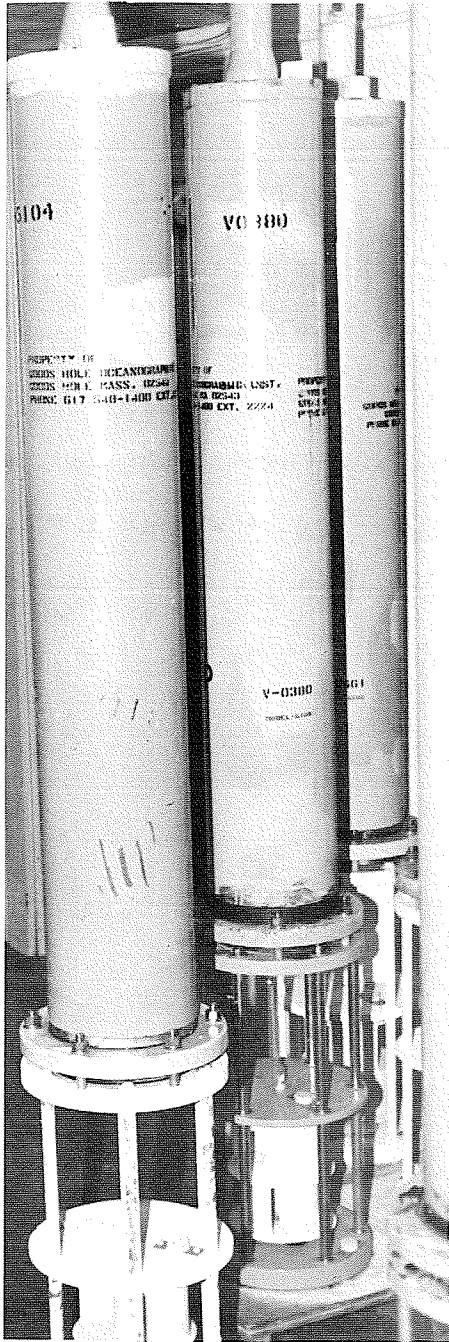

VACM Current Meters

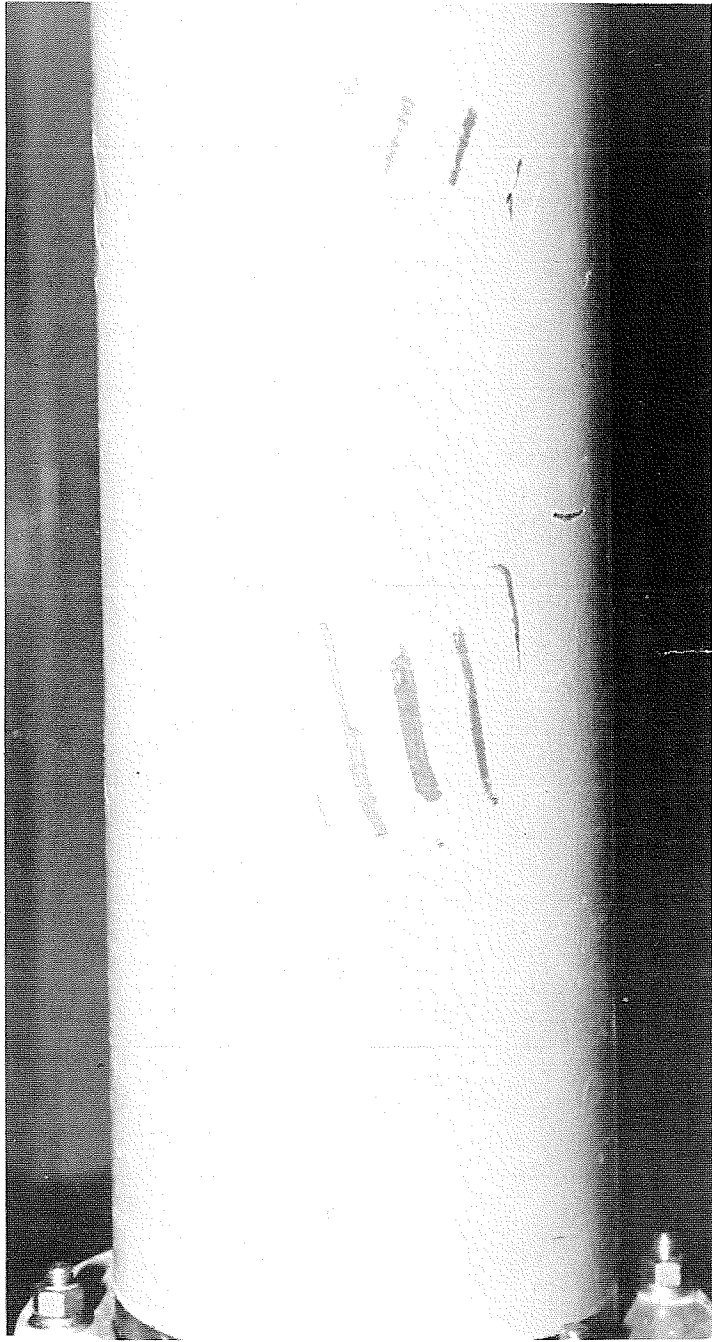

Close up of teeth marks

Figure 1.7 Shark attack on current meter set 20 meters below the surface
(1986 - 27°N 69°43'W).

1.4. Fishbite attacks on components other than mooring lines.

Although this handbook is concerned primarily with deep sea lines, one's view of the fishbite problem should not be myopic. For example, an intriguing case of fishbite is that involving the 18 inch long Cigar shark of "cookie cutter" shark (Isisti brasiliensis), which became a major nuisance in the operation of U.S. submarines (Gray, 1979). There is evidence also that fishbite attack, by as yet unknown creatures, may have caused damage to Savonius rotors and small plastic propellers used in current meters. On occasions as evidenced by Figure 1.7, sharks will even attack an entire instrument case.

CHAPTER 2 - DETECTION AND IDENTIFICATION OF FISHBITE DAMAGE

Granted that fishbite is a cause of damage to deep sea lines, how does one go about distinguishing it from other types of damage when confronted with an item which has failed or was damaged in service? In a few cases, biting has been observed while in progress, or teeth may be found embedded in an area of damage. Most of the time however, it is necessary to arrive at a conclusion by assembling bits of evidence long after the event. Nevertheless, conclusions can be reached with assurance if observations are made and recorded in an educated way.

2.1. Systematic documentation of damaged mooring components.

Confidence in drawing conclusions about causes of damage is greatly strengthened if a complete account of the identity, composition, and service record of an item are available. Obvious as it may seem, the simple matter of identity is all too often a stumbling block. The importance of knowing exactly what an item is and where it was located in an array cannot be overstated. If possible, a diagram showing the location of the damaged or failed item in the array is very helpful. In addition, the item must be clearly and permanently marked so there can be no mistake about its identity.

Field records which can be helpful in deciding whether fishbite has occurred are suggested in Figure 2.1.

FISHBITE DATA SHEET

Please fill as many data items as possible.

Attach mooring diagram if available.

REPORTED BY: _____

ADDRESS: _____

_____ TELEPHONE NO: _____

Mooring Information

Site Deployed: Lat. _____

Long. _____

Water Depth _____

Buoy Depth: _____

Date Set: _____

Date Recovered: _____

Mooring Line Information

Diameter: _____

Material: _____

Aarmor: _____

Observed Bites

Number: _____

Depth range: _____

Type: _____

Comments _____

Figure 2.1 Fishbite Data Sheet.

2.2. Observations made on shipboard at time of recovery.

If possible, the first observations should be made as the mooring line is being hauled from the water. On deck, opportunities for close observation vary greatly with working conditions, but as much as possible of the following should be done:

2.2.1. Plastic covered lines.

- a. Visually observe the line for cuts, gouges, and scrapes.
- b. Detect rough spots in plastic covered lines by letting it run loosely through the finger tips while hauling (with due caution!).
- c. Mark sites of suspected damage with tape, tag, or paint.

2.2.2. Unjacketed synthetic fiber lines.

- a. Watch for sharply cut yarns which stick out from the surface of the line, and other evidence of biological activity, such as fouling and slime.
- b. Mark sites of suspected damage with tape, tags, or paint.

In either case a brief description of the damage, its depth, the identity of the damaged item, and the date should be recorded. In addition the whole line or at least the damaged portion should be saved for later study in the laboratory.

2.3. Laboratory study.

2.3.1. Confirmation of shipboard observations.

In the laboratory, a line suspected of having been bitten should first be examined as received. If by good fortune, the whole shot of line

is available, it should be examined foot by foot for indications of fishbite and other biological activity such as fouling. For this purpose it is convenient to have reels for the line and a means for measuring line length. It is convenient to observe the line at approximately one meter above floor level. Lighting should be bright because one is often looking for small cuts and scratches in a black material. A small magnifying glass of about 10X power is helpful for closer observations.

All cuts and other suspicious marks should be logged noting distance from one end of the line, to permit determination of the depth at which damage took place. Such a procedure is at times tedious, but experience has shown that it usually leads to discovery of more biting damage than is seen at sea where the main concern must be hauling the line on schedule. It is during this close examination that teeth and tooth fragments are most likely to be found.

After detailed examination, the line sample should be rinsed in fresh water and dried for microscopic examination. Methods for laboratory examination of plastic covered lines and uncovered synthetic fiber lines are hereafter reviewed.

2.3.2. Examination of plastic jacketed lines.

Plastic covered or jacketed lines usually retain dental impressions when bitten. Some may be quite graphic, as in the case of the cigar shark reported by Gray, 1979. In that case, the dental record was so good that Gray was able to make a plaster cast which replicated the tooth pattern of the shark beyond question. Most of the time, dental impressions are less complete, but still useful. Patterns of tooth spacing may be found, as in Figures 1.5 and 1.6, the former reflecting spacing of teeth along a jaw,

the latter, jaw width. In Figure 1.4 one can see a curved bottom in a long furrow. Close study under the microscope reveals that the radius of curvature is like that found at the ends of fish teeth. Some fish teeth have wavy scalloped edges which are reflected by patterns left in plastic (Figures 1.3 and 1.4). When markings are of biological origin, they tend to show organized patterns unlike those which are caused by contact of the plastic surface with rough steel or concrete.

Many fishbites are characterized by being clean, sharp cuts, as shown in Figure 2.2. The cuts shown in the hard plastic boot must have been caused by a very keen edge. They cannot be duplicated by cutting with the blade of an ordinary pocket knife or even a new razor blade.

Finding teeth or tooth fragments in a plastic jacket is of course the ultimate confirmation that fishbite has occurred. Occasionally, whole teeth may be found, but more often there are only fragments identifiable as bits of tooth but not sufficient for identification of the biter. Extracting tooth fragments embedded in tough plastic is often frustrating.

Figures 2.3 and 2.4 illustrate two methods for observing teeth in situ. The diameter of the damaged cable was about 19 mm. The cable contained a power line which shorted out when the jacket was punctured. Cause of the damage and of the short was fishbite as evidenced in both pictures. In this case, whole teeth were recovered.

Figure 2.3 shows three teeth in the jacket to the left of the blow-out hole. The jacket was polyethylene which was heated to make it more transparent revealing the embedded teeth.

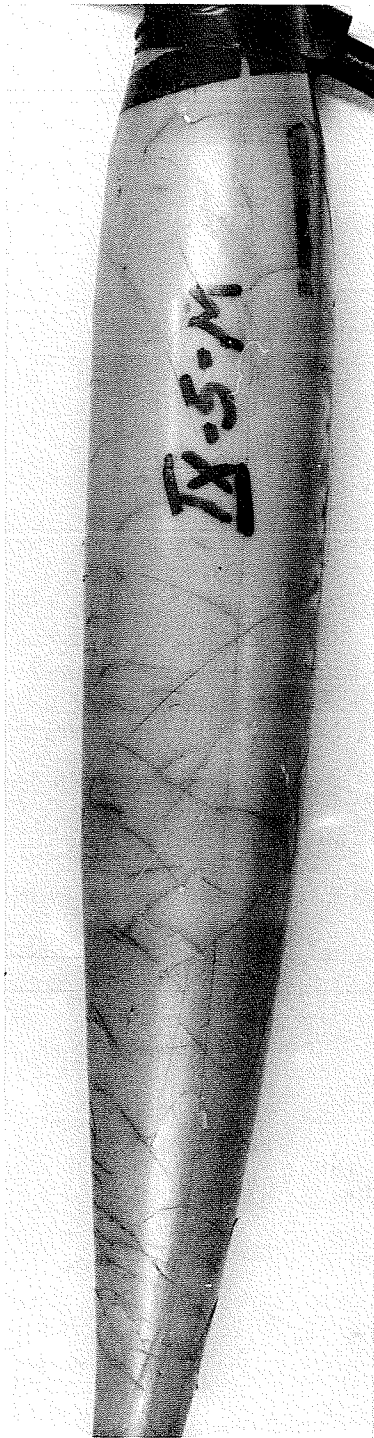

Figure 2.2 Wire rope termination boot showing numerous fishbite cuts.

(WHOI #665)

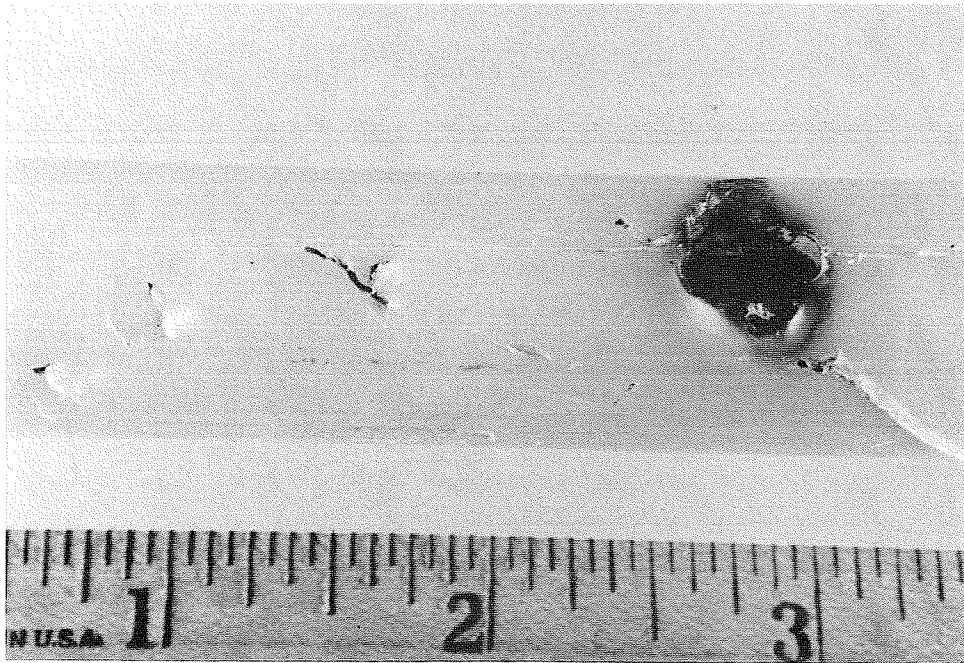

Figure 2.3 Shark teeth in heated polyethylene jacket. The black hole resulted from a short circuit.



Figure 2.4 An Xray of the line shown in Fig. 2.3. Reveals the shark teeth in situ.

Figure 2.4 is an Xray of the same specimen shown in Figure 2.3. The blow-out hole and spacing of the embedded teeth are clearly visible.

In summary, recognition of fishbite in a plastic jacketed item results from observations on:

1. Tooth fragments
2. Dental impressions
3. Pattern of cuts
4. Sharpness of cuts

2.3.3. Identification of fishbite in unjacketed fiber lines.

Fishbites in unjacketed fiber lines may show up as sharply cut yarns or strands which often stick out from the side of a rope as seen in Figure 1.1. If the line has parted in service, and only a fag end is retrieved, it will often be found that many of the yarns have truncated ends, which indicates cutting by a sharp instrument, such as fish teeth. At the same time, the ends of a few yarns may have a "ponytail" appearance, which is indicative of tensile failure. Such a pattern is characteristic of a line which had most of its yarns cut by fishbites, leaving only a few yarns to sustain the tensile load (Figure 2.5).

A reasonable assessment of the modes and causes of a rope failure almost invariably requires a formal investigation conducted in the laboratory.

The fag end of line which reaches the laboratory may have undergone misadventures such as: lost at sea for several months, dragged over a rough bottom, taken apart for preliminary study, or just left out in the

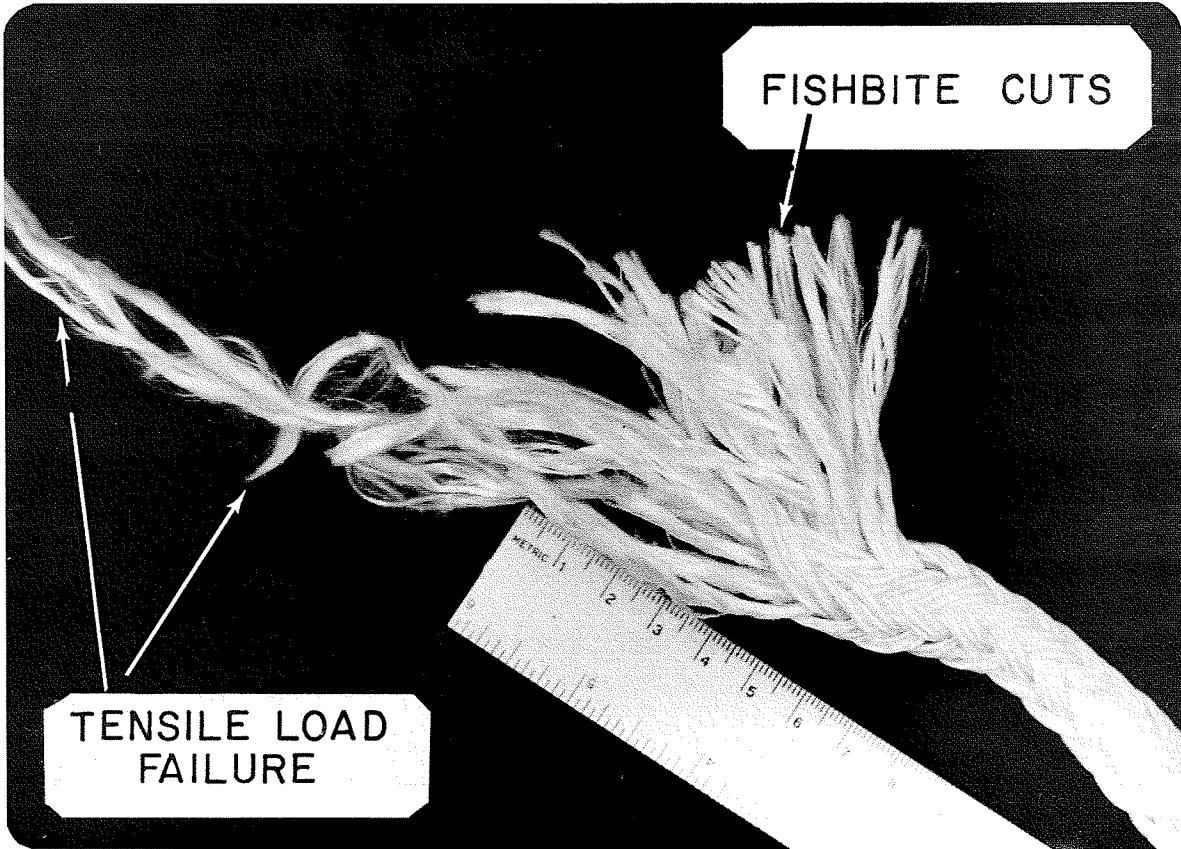

Figure 2.5 Synthetic fiber rope typical fishbite failure.

weather for awhile. The result is often a hopeless looking, amorphous mess of dirty fiber. Yet, a record of the cause of fiber failure usually remains in the morphology of the fiber ends. It can be read under the microscope as demonstrated by the work of Hartman (1972). Because of the small size and toughness of synthetic fibers, together with their immunity to biological degradation, such patterns persist and provide a durable record of disaster.

The steps followed in the laboratory analysis of failed ropes include:

- . Preparation of representative samples for macroscopic and microscopic examination.
- . Distribution of failed fiber ends into representative categories.
- . Comparison of the data set obtained against standards.
- . Interpretation and report.

2.3.3.1. Sample preparation. The samples should be obtained from a length of damaged line which has been washed in fresh water and dried. Suspicious cuts are identified and tagged (Figure 2.6). Fibers from damaged yarns are then collected (Figure 2.7) and mounted on microscope slides as shown in Figures 2.8 and 2.9.

SAMPLE PREPARATION FOR MICROSCOPIC ANALYSIS OF FAILED FIBER ROPES



Figure 2.6 Parted mooring line (washed and dried).

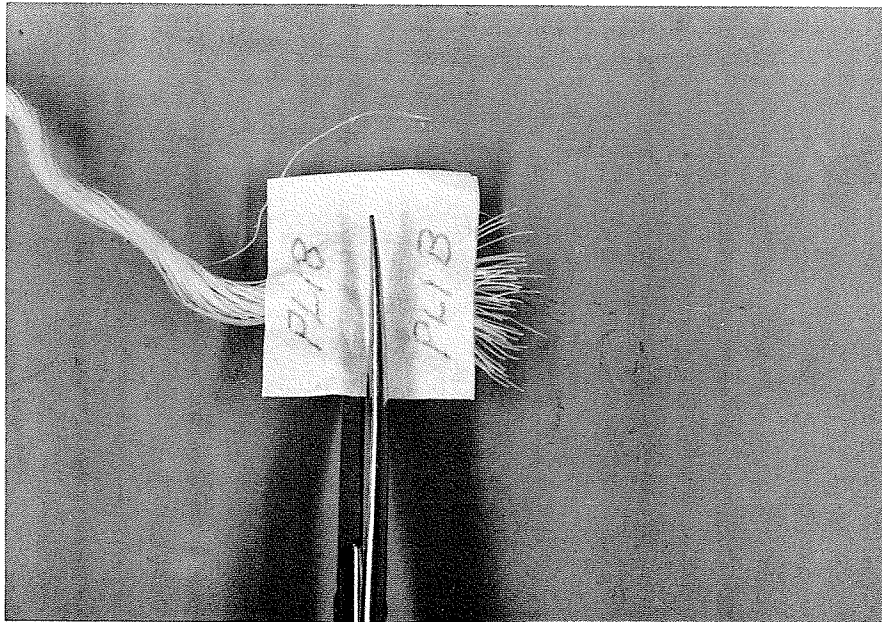

Figure 2.7 Representative fiber ends are placed between two layers of scotch tape. The sample is then cut with scissors.

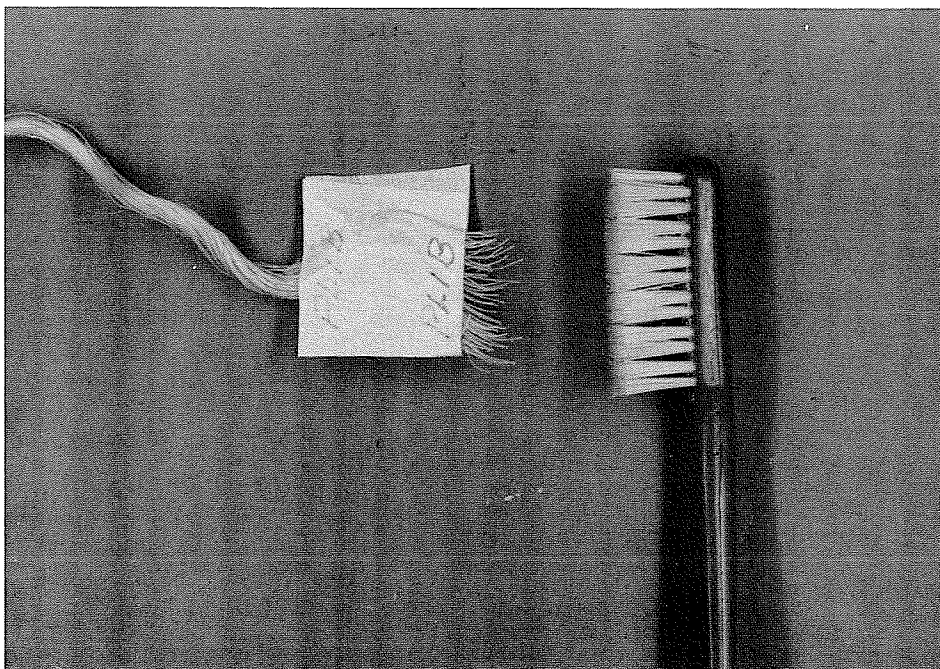

Figure 2.8 Fibers are brushed and mounted on a microscope slide.

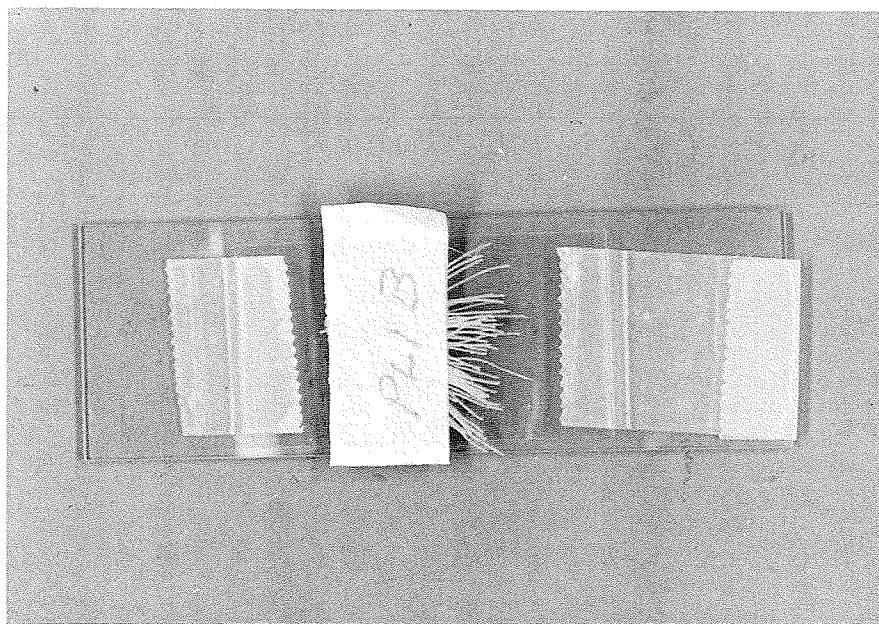

Figure 2.9 The sample is covered with glass and ready for examination.

2.3.3.2. Microscopic examination. The fibers should be observed at 100X magnification. In a given sample, each fiber should be identified and cataloged as belonging to one of the following types or categories (See Figure 2.10):

- a. Sharp cut - Fiber ends are cut cleanly with a plane surface. Little or no distortion of fiber at cut.
- b. Shear cut - Fiber end distorted when cut. May be bent or flattened in direction of applied force.
- c. Fused - End of fiber usually rounded, may be dark in color, and sometimes bonded to adjacent fibers. May show small drawn out fibrils.
- d. Attenuated - End of fiber is reduced in diameter, may or may not come to a point, analogous to cup and cone failure of steel wires.
- e. Fractured - End of fiber is broken with little or no change in diameter, rough, angular surface at break, not rounded.
- f. Splintered - Fiber split longitudinally into smaller segments.
- g. Torn - End of fiber ripped, mashed, pulled apart, severely damaged and misshapen.
- h. Other - Fiber ends which have an appearance different from the above categories.

The number of samples needed will vary with the size of the rope and with the kinds of damage observed in the fiber ends.

Experience has indicated that classifying the damaged fiber ends into the eight categories listed above is usually sufficient for the purpose of determining causes of line failure. However, it is important to keep an

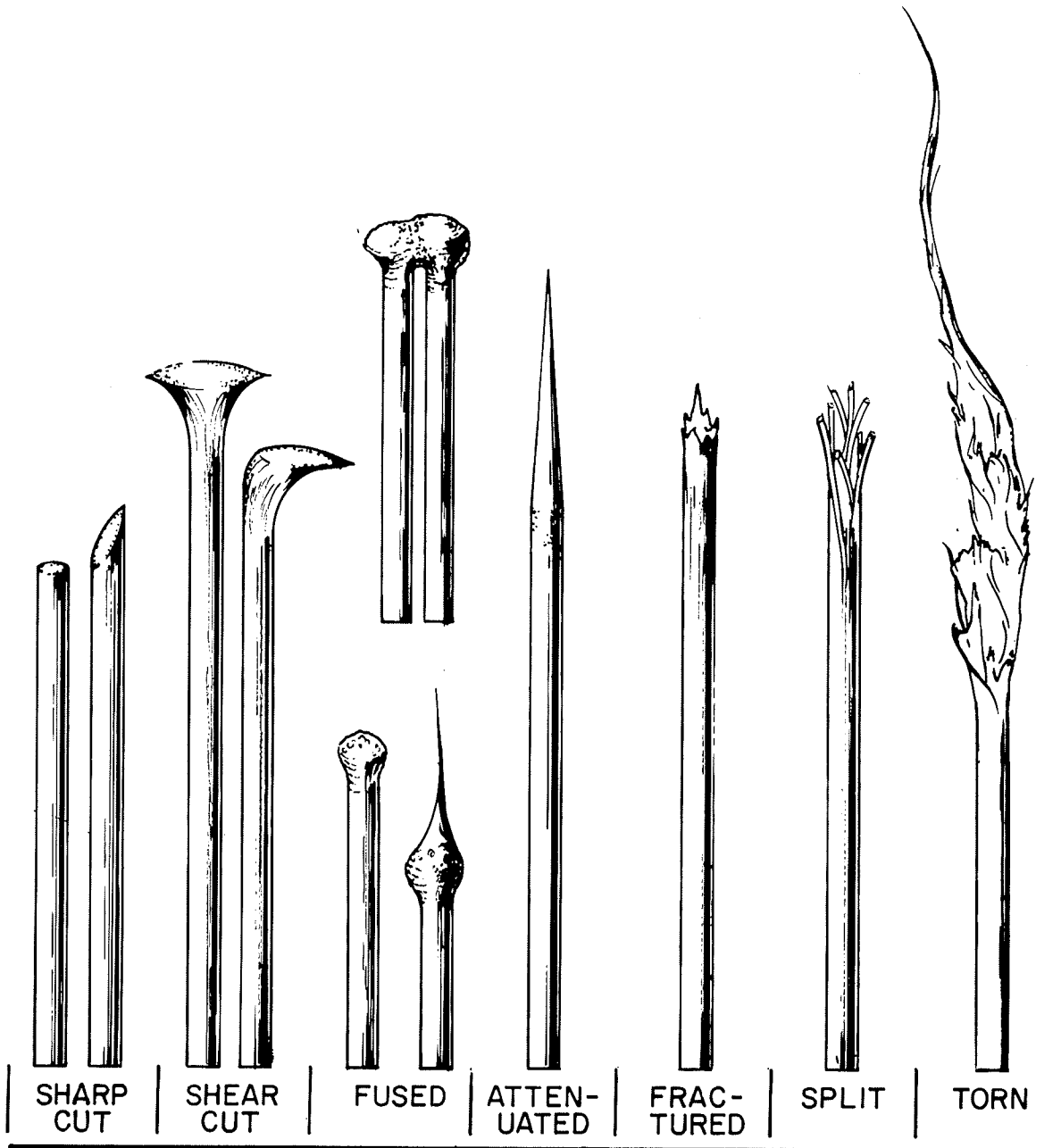

Figure 2.10 Types of failed fiber ends.

eye on the "Other" column. If this number is more than ten percent of the total, it may be a signal that there is some unsuspected cause of damage.

It would be convenient indeed if a single cause of damage would yield a definite, characteristic appearance of all damaged fiber ends, i.e. all neatly cut or all roughly torn.

Experience, however, has shown that this rarely happens. Every sample will contain ends which fall into several categories even when a single cause of damage is involved. The following example illustrates the point.

Two samples of the same rope were cut in different ways. The fiber ends of samples A and B were categorized and distributed as shown in Table 2.1.

Table 2.1
Fiber Ends - Each Type - Percent

Sample	Comments	Sharp cut	Shear cut	Fused	Attenuated	Fractured	Splintered	Torn	Other
A	Nylon Razor cut (in water)	87	9	3	0	1	0	0	0
B	Nylon Knife cut (in water)	5	63	13	2	2	0	15	0

Sample A was cut with a new razor blade while under light tension. As expected, most fibers (87%) had "Sharp cut" ends, meaning that the cut was clean with little distortion of the fiber cross section. 9% of fiber ends were "Shear cut" which means a distortion of the ends in the direction of applied force, typical of a scissors cut. 3% were "Fused" which suggests failure at a high temperature or from tensile load.

Now compare these results with the data from Sample B. Only 5% of fibers were "Sharp cut," 63% were "Shear cut," 13% "Fused," 2% "Attenuated," 2% "Fractured" and 15% "Torn." Having no other information on Sample B, it might be logical to conclude that it had been cut with a shearing device, perhaps a wire cutter, and perhaps there had been abrasion in addition to cutting. In fact, it was cut with a pocket knife. The large percentage of "Shear cut" and "Torn" fibers were the result of cutting with a blade which has a relatively dull, rough edge.

From the above example, it is evident that one cannot expect all fiber ends of a cut line to look alike. Their appearance usually depends on the cutting tool.

Experience also shows that the same cause of damage produces different effects on fibers made of different materials. For example when broken by tension, ends of nylon tend to fuse, where as ends of Kevlar tend to split. Moreover, in practical situations more than one cause of failure may be involved i.e. cutting followed by tensile failure, or abrasion followed by tensile failure.

It is thus evident that one cannot positively ascertain the cause of a particular failure by mere microscopic examination. What is observed microscopically is not the cause of failure, but merely the appearance of fiber ends which have yielded to stress.

Confronted with the complexity of the problem one must carry the investigation further and compare the data obtained from the field against standard data obtained under controlled conditions.

2.3.3.3. Standards of comparison. To be useful the comparison standards must reproduce the causes and modes of damage most likely to be

encountered in mooring line service and encompass the rope materials and configurations commonly used for deep sea applications. To this end samples of four widely used fiber ropes were systematically subjected to fourteen types of damage. A matrix of 48 Standards was thus made.

Photographs of each damaged sample and microphotographs of their damaged fibers were made. All damaged ends were examined to obtain their characteristic statistical signature following the laboratory procedure previously described.

This body of information is presented in the collection of macro- and micro-photographs shown in Figure 2.12 to 2.35. Photographs and accompanying comments are grouped first by type of rope in the order: DACRON, NYLON, POLYPROPYLENE, KEVLAR, and then by type of damage within each rope type. The percentage distributions of fiber end appearances as a function of damage causes and sample conditions for the four rope materials are shown in Figure 2.36 to 2.39. Details on the fiber ropes used and types of damage inflicted follow:

The four fiber ropes used to prepare the samples were:

- . DACRON[®]- (Polyester) 3/8 inch diameter, 12 strands, single braid (Samson Cordage).
- . NYLON - 3/4 inch diameter, 8 strands, plaited (Colombian Cordage Group).
- . POLYPROPYLENE - 1/2 inch diameter, 3 strands, stranded (Colombian Cordage Group).
- . KEVLAR[®]- 1/4 inch diameter, jet strand, parallel yarns encased in a braided Dacron cover (Whitehill Manufacturing Co.).

"Causes" of damage inflicted to each of these rope types were as follows:

1. Fishbite - The teeth of an Oceanic White Tip shark were first used to simulate fishbite in lines under tension (Figure 2.11). New shark teeth are not commonly available for routine testing. Very sharp steel blades (Stanley Heavy Duty Knife Blade #1992) were found to have a cutting edge similar to that of shark teeth and were subsequently used as an adequate and practical ersatz.

2. Knife cut - A fairly sharp pocket knife was used to make a series of cuts such as might occur when a rope was being prepared for use or recovered from service. As a rule the pocket knife blade is not quite as keen as fish teeth or a utility knife blade and in making a cut causes more shearing and tearing.

3. Cut with wire cutter - Ropes are often cut on shipboard or in the shop using a wire or cable cutter. This tool has edges which are not as sharp as those of a knife but have a strong shearing action. As a result, the fiber ends are characteristically more torn, sheared, fractured or split than those produced by a knife or a shark tooth.

4. Tensile break - Samples were pulled to destruction in a Baldwin Universal Testing machine. As previously noted, this cause of failure results in fiber ends of different sorts depending on the fiber material.

5. Abrasion - Abrasion was reproduced by rubbing the rope samples back and forth against an abrasive tool such a rough file or a concrete block. This form of abuse produces torn and entangled fiber ends which gives a fuzzy appearance to the damaged area.

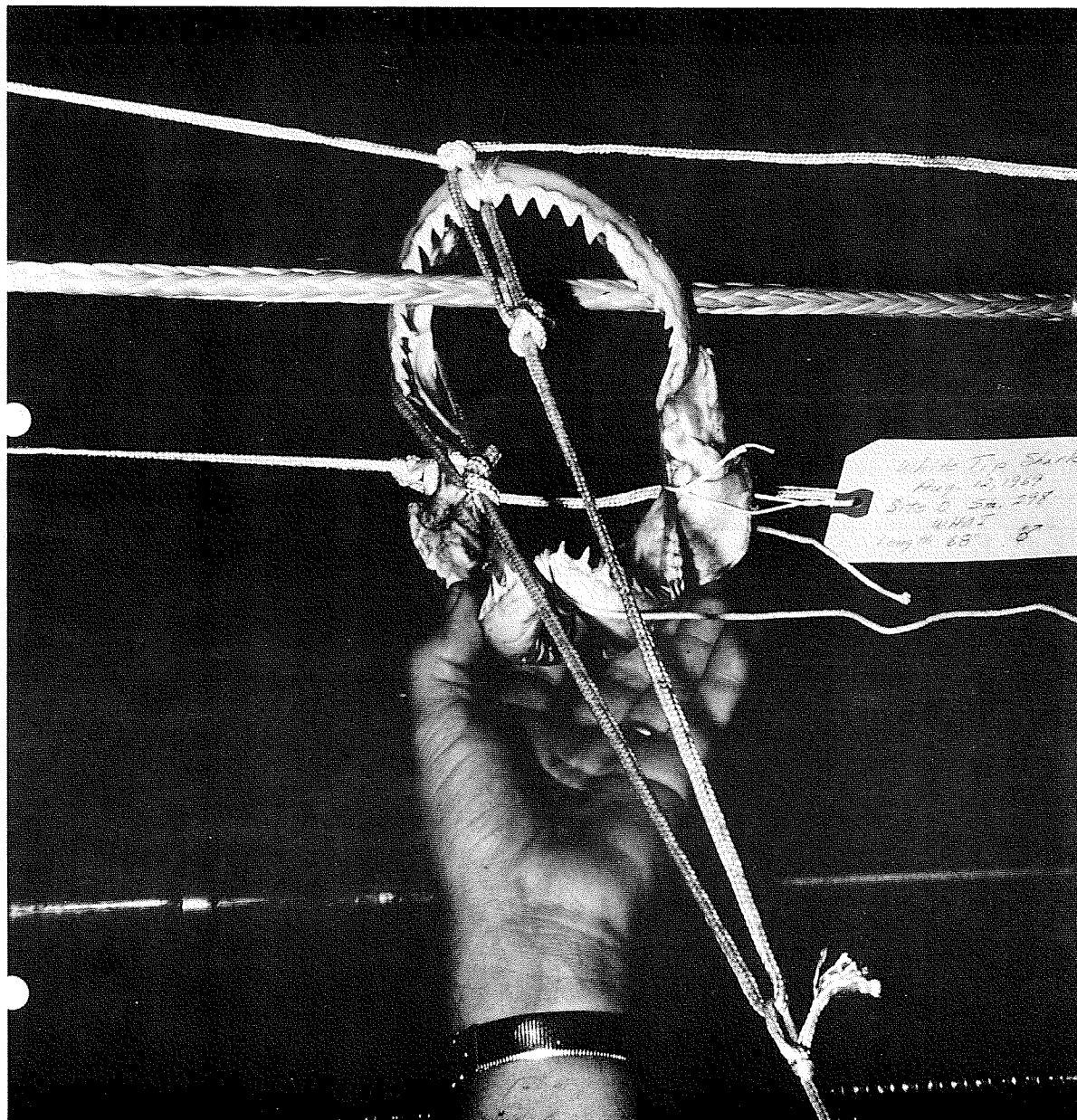

Figure 2.11 Simulated fishbite. Nylon rope under tension cut by shark teeth.

In addition to damage causes, the condition of the samples at the time the damage is inflicted has a strong bearing on the resulting appearance of the damaged fibers. Several conditions which could prevail during the life of deep sea lines were considered. They are designated as follows:

1. Immersed - Lines are damaged while completely submerged. This condition can influence the appearance of fiber ends in a least two ways. Presence of water can serve as a lubricant when the line is cut or abraded. Secondly, the cooling effect of water affects the amount of fusion when fibers break from tension pull.
2. 1000 lbs. Tension - To properly document the differences between the ends of ropes damaged when slack from those damaged while under tension, a number of test samples were pulled to a standard 1000 lbs. tension as they were cut or abraded. 1000 lbs. is the average load sustained by synthetic fiber ropes when deployed on many deep sea subsurface oceanographic moorings.
3. Saturated - To simulate situations where a line was removed from underwater service and shortly thereafter damaged in one way or another, "Saturated" rope samples were left in water for 24 hours and then damaged, still dripping wet.
4. Dry - Dry ropes designate new rope samples which were damaged under ambient conditions prevailing in the laboratory. These were needed as control samples for comparison against samples damaged under immersed and or saturated conditions. They could also be used to help identify damage which could fortuitously occur at the time of rope manufacturing, handling and/or service preparation.

Thus in all 14 combinations of damage causes and sample conditions were devised and systematically applied to four different ropes. Photographical and statistical results obtained from the failure analysis of the 48 samples are presented in pages 33 to 80.

Numbers in the percentage distribution listings (pg. 82 to 85) represent the percent of fiber ends out of all fibers included in the sample which show a specific appearance.

Example: Material: KEVLAR (pg. 85)

Cause of damage: Shear cut

Condition of sample: Saturated, no load

Percent of ends having a shear cut appearance = 75

Percent of ends having a fractured appearance = 2

Bold digits have been used to emphasize the most frequent appearances and thus call attention to these appearances which best associate with particular modes of failures.

The comparison standards just described are far from being comprehensive. They are tailored for specific needs of the Woods Hole Oceanographic Institution. They do not cover all types of rope material or construction. However, they are indicative of a methodology which can profitably be pursued to develop specific standards for other types of mooring components, other oceanic applications, or other modes of failure. The signatures of fiber optic cables failing under longitudinal and/or bending fatigue would be a good example.

STANDARDS

OF

COMPARISON

POLYESTER	PAGE 33 TO 44
NYLON	PAGE 45 TO 56
POLYPROPYLENE	PAGE 57 TO 68
KEVLAR	PAGE 69 TO 80

MACROSCOPIC

Yarn ends cleanly cut at differing lengths due to the location of teeth and release of tension.

Yarn end shown is typical of a cut with a very sharp blade.

Yarns sharply cut to varying lengths as tension releases with strokes of the knife.

MICROSCOPIC

Fiber ends shown are Sharp cut.

Predominant end types -
Ave. of 5 fiber samples
35% Sharp cut
63% Shear cut

Two fiber ends are Sharp cut at different angles.

Predominant end types -
Ave. of 5 fiber samples
29% Sharp cut
65% Shear cut

Yarn ends shown are Sharp cut.

Predominant end types -
Ave. of 5 fiber samples
25% Sharp cut
66% Shear cut

POLYESTER

MACROSCOPIC

MICROSCOPIC

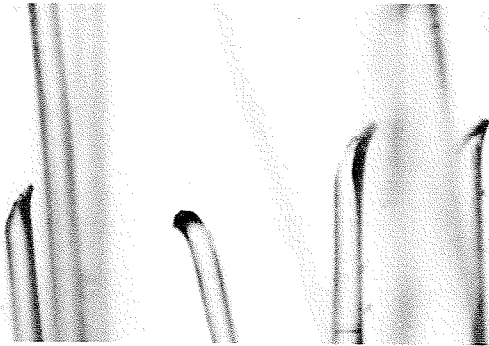
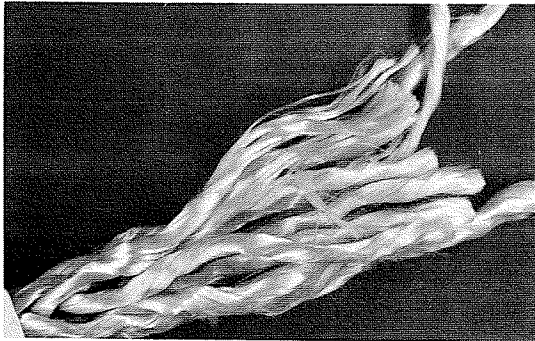

CAUSE OF DAMAGE — SHARK TEETH

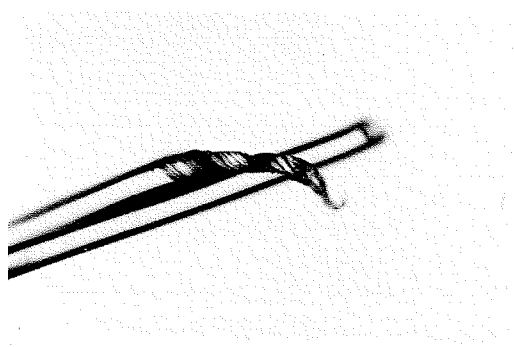
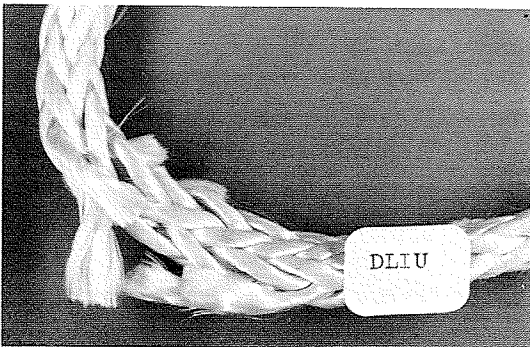

CAUSE OF DAMAGE — UTILITY KNIFE BLADE

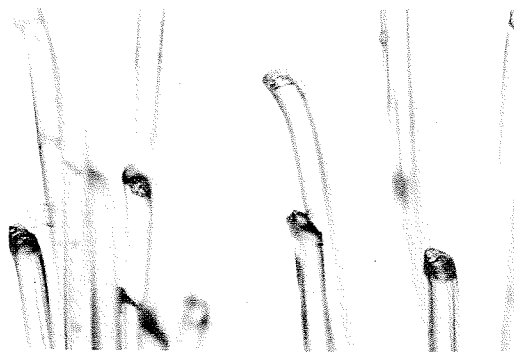
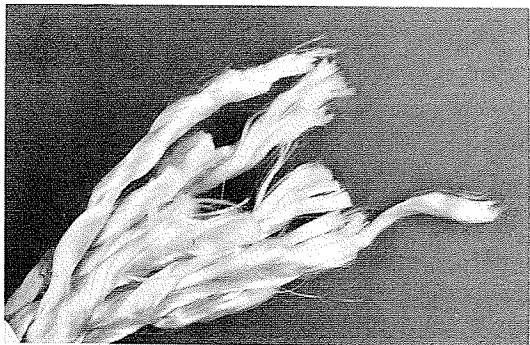

CAUSE OF DAMAGE — POCKET KNIFE

CONDITION OF ALL SAMPLES WHEN DAMAGED —
IMMERSED IN SEA WATER; 1,000 POUNDS OF TENSILE LOAD

Figure 2.12

MACROSCOPIC

Yarn ends squarely cut off at the same length.

Yarn ends squarely cut off.
They have a tendency to be fuzzy.

MICROSCOPIC

The fiber ends shown are cleanly cut but have some distortion which causes them to be classified as Shear cut.
Predominant end types -
Ave. of 5 fiber samples
91% Shear cut

Several kinds of fiber ends are shown. The ends of the fibers are contorted and tangled.
Predominant end types -
Ave. of 5 fiber samples
64% Shear cut
17% Fused
12% Torn

POLYESTER

MACROSCOPIC

MICROSCOPIC

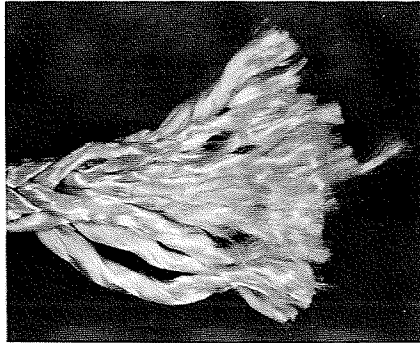

CAUSE OF DAMAGE — POCKET KNIFE

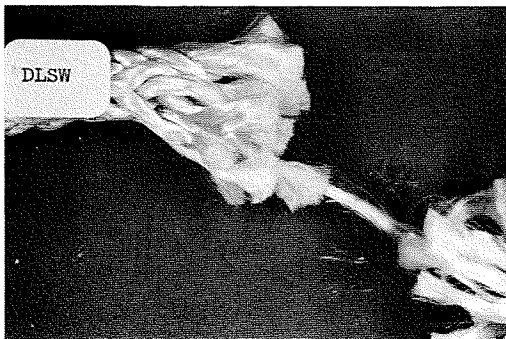

CAUSE OF DAMAGE — WIRE CUTTER

CONDITION OF ALL SAMPLES WHEN DAMAGED —
WATER SATURATED; 1,000 POUNDS OF TENSILE LOAD

Figure 2.13

MACROSCOPIC

Yarns squarely and cleanly cut.
All the same length.

Yarns all cut about the same
length and have fuzzy ends.

MICROSCOPIC

Fiber ends are largely Shear
cut.

Predominant end types -
Ave. of 5 fiber samples
10% Sharp cut
79% Shear cut

Ends of fibers are bent,
mashed, and many on the
borderline of being torn.
Predominant end types -
Ave. of 5 fiber samples
79% Shear cut

POLYESTER

MACROSCOPIC

MICROSCOPIC

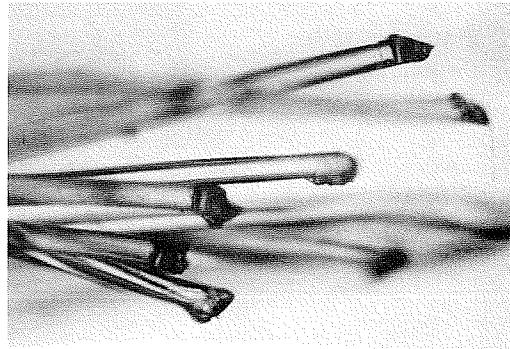
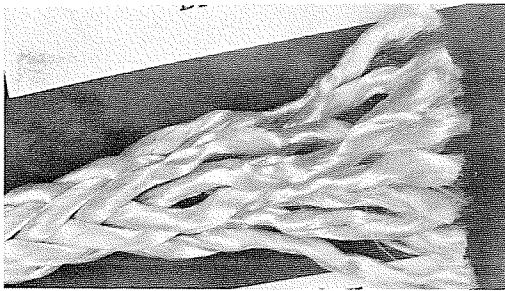

CAUSE OF DAMAGE — POCKET KNIFE

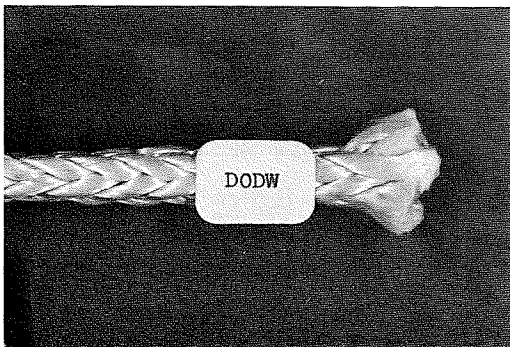

CAUSE OF DAMAGE — WIRE CUTTER

CONDITION OF ALL SAMPLES WHEN DAMAGED —
DRY; NO TENSILE LOAD

Figure 2.14

MACROSCOPIC

End of rope and ends of yarns
squarely and cleanly cut.

Ends of rope and yarns are
squarely cut off. In this case
there are dark marks near the
cut. They are rust stains often
found when a tool used near salt
water has been used to make the
cut.

MICROSCOPIC

Ends of fibers photographed
are Shear cut and at least
one has a Sharp cut end.
Predominant end types -
Ave. of 5 fiber samples
11% Sharp cut
88% Shear cut

Fiber ends shown are Shear
cut and distorted.

Predominant end types -
Ave. of 5 fiber samples
90% Shear cut (some almost
torn)

POLYESTER

MACROSCOPIC

MICROSCOPIC

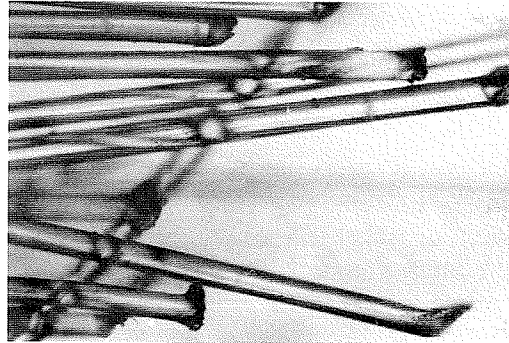
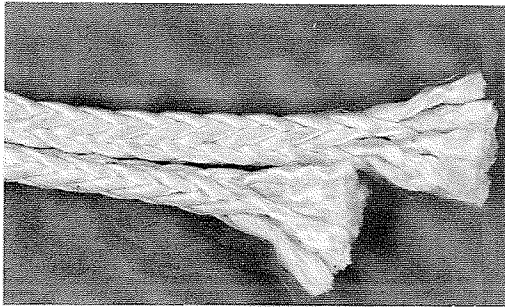

CAUSE OF DAMAGE — POCKET KNIFE

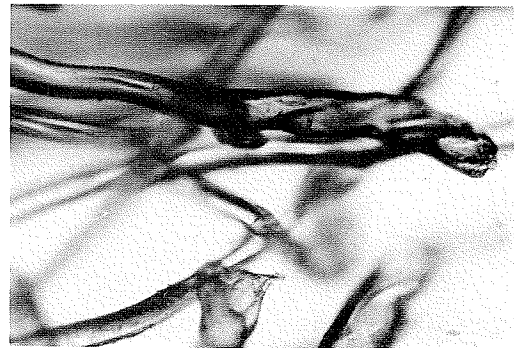
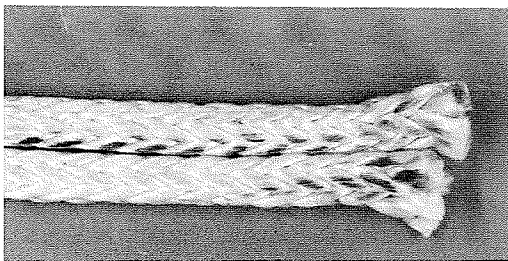

CAUSE OF DAMAGE — WIRE CUTTER

CONDITION OF ALL SAMPLES WHEN DAMAGED —
WATER SATURATED; NO TENSILE LOAD

Figure 2.15

MACROSCOPIC

Ends of yarns are fuzzy and rope structure destroyed at the site of damage.

Ends of yarns are uneven and tend to be fuzzy.

MICROSCOPIC

The fiber end shown is Torn.
Predominant end types -
Ave. of 5 fiber samples
66% Shear cut
27% Torn

The fiber ends shown are Fractured.

Predominant end types -
Ave. of 5 fiber samples
18% Sharp cut
36% Shear cut
15% Fractured
26% Torn

POLYESTER

MACROSCOPIC

MICROSCOPIC

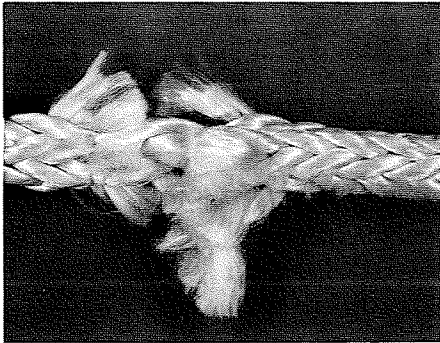

CAUSE OF DAMAGE — ABRASION WHEN DRY

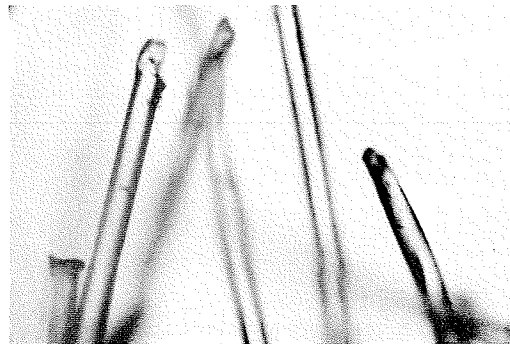

CAUSE OF DAMAGE — ABRASION WHEN IMMERSSED IN SEA WATER

CONDITION OF ALL SAMPLES WHEN DAMAGED —
1,000 POUNDS OF TENSILE LOAD

Figure 2.16

MACROSCOPIC

Rope end shows marked effect of recoil when broken. Yarns and strands are stuck together. Fiber ends are of uneven length.

Broken end is jagged due to uneven length of yarns and fibers.

Broken end is jagged due to uneven length of yarns and fibers. Adjacent rope structure has been disturbed by recoil.

MICROSCOPIC

The photograph shows a group of fiber ends which have fused and stuck together.

Predominant end types -

Ave. of 5 fiber samples
25% Shear cut
55% Fused

Fiber ends shown are Fused and tangled as a result of recoil when broken.

Predominant end types -

Ave. of 5 fiber samples
33% Shear cut
51% Fused

Fiber ends shown are Fused. Predominant end types -

Ave. of 5 fiber samples
14% Shear cut
32% Fused
37% Fractured
11% Torn

POLYESTER

MACROSCOPIC

MICROSCOPIC

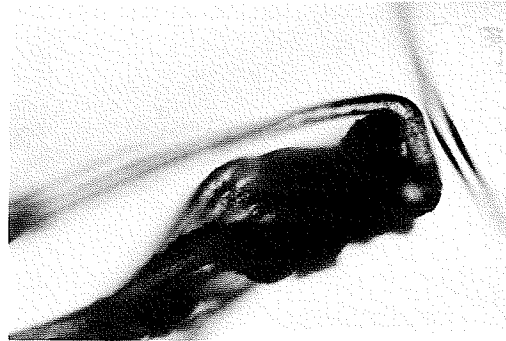
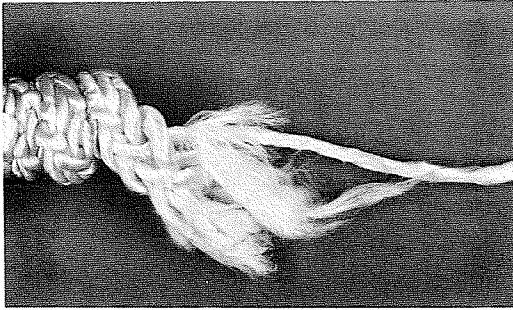

CAUSE OF DAMAGE — TENSION PULL WHEN DRY



CAUSE OF DAMAGE — TENSION PULL WHEN WATER SATURATED

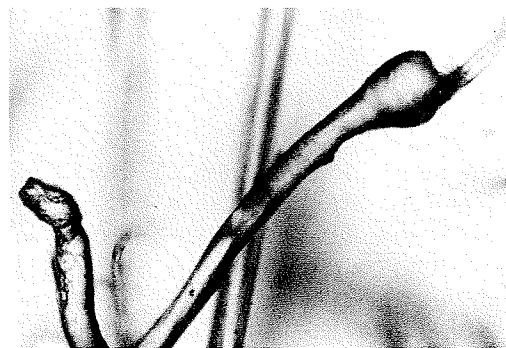

CAUSE OF DAMAGE — TENSION PULL WHEN IMMERSSED IN WATER

ALL SAMPLES PULLED UNTIL TOTAL FAILURE

Figure 2.17

MACROSCOPIC

A few cut yarns. Typical of a nibbling fishbite attack.

Yarns have clean cut, square ends.

Yarns have square, clean cut ends. Rope is partially cut through at several locations due to strokes of the knife and tension pulling away cut yarns.

MICROSCOPIC

Fiber ends characteristic of cutting by fish teeth; ends sharply cut with very little distortion.

Predominant end types -

Ave. of 5 fiber samples
64% Sharp cut
26% Shear cut

Fiber ends characteristic of cutting by a very sharp steel edge. Clean cut with little distortion of fiber ends.

Predominant end types -

Ave. of 5 fiber samples
48% Sharp cut
50% Shear cut

Ends of fibers are quite cleanly cut, but most of them show distortion in the direction of travel of the knife to blade.

Predominant end types -

Ave. of 5 fiber samples
24% Sharp cut
67% Shear cut

NYLON

MACROSCOPIC

MICROSCOPIC

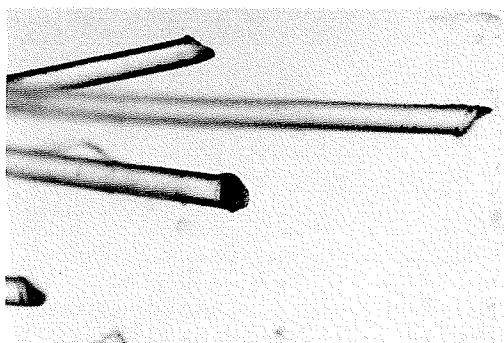
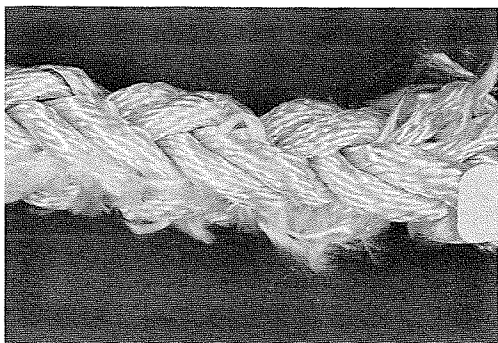

CAUSE OF DAMAGE — SHARK TEETH



CAUSE OF DAMAGE — UTILITY KNIFE BLADE

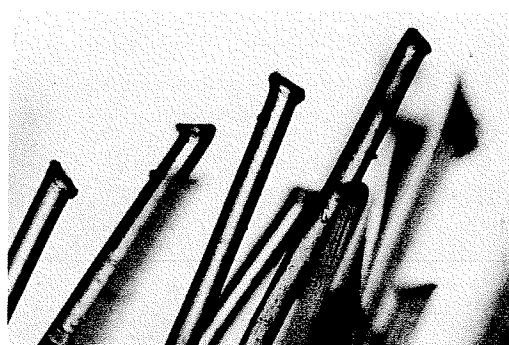
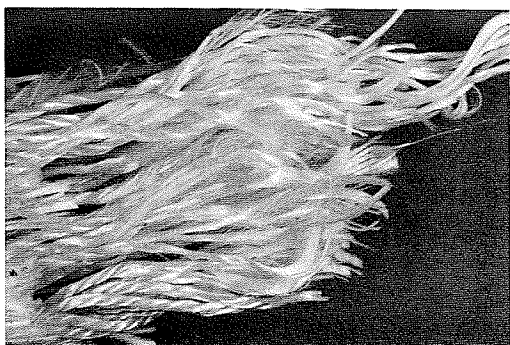

CAUSE OF DAMAGE — POCKET KNIFE

CONDITION OF ALL SAMPLES WHEN DAMAGED —
IMMERSED IN SEA WATER; 1,000 POUNDS OF TENSILE LOAD

Figure 2.18

MACROSCOPIC

Yarns have square, clean cut ends with some variation in length due to strokes of the knife cutting part way through the line and release of tension during cutting.

All yarns are cut off at the same length. Cut ends tend to be fuzzy.

MICROSCOPIC

Fiber ends are cleanly cut but show distortion in the direction of travel of the knife blade.

Predominant end types -
Ave. of 5 fiber samples
34% Sharp cut
61% Shear cut

Ends of fibers have marked distortion in the direction of shear and some Torn or Fused.

Sharp cut fiber ends are notably lacking.
Predominant end types -
Ave. of 5 fiber samples
70% Shear cut
9% Fused
9% Torn

NYLON

MACROSCOPIC

MICROSCOPIC



CAUSE OF DAMAGE — POCKET KNIFE



CAUSE OF DAMAGE — WIRE CUTTER

CONDITION OF ALL SAMPLES WHEN DAMAGED —
WATER SATURATED; 1,000 POUNDS OF TENSILE LOAD

Figure 2.19

MACROSCOPIC

Fiber ends are squarely and cleanly cut at the same length.

Yarns are cut to approximately the same length and tend to be fuzzy where cut.

MICROSCOPIC

Fiber ends show some tearing and are distorted somewhat in the direction of travel of the knife blade.

Predominant end types -

Ave. of 5 fiber samples

22% Sharp cut

72% Shear cut

The fiber ends shown reflect the shearing action of the relatively dull wire cutter blades. There is much contortion of the ends and almost all were Shear cut.

Predominant end types -

Ave. of 5 fiber samples

87% Shear cut

NYLON

MACROSCOPIC

MICROSCOPIC

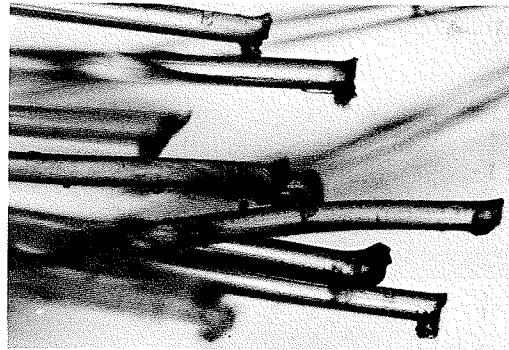
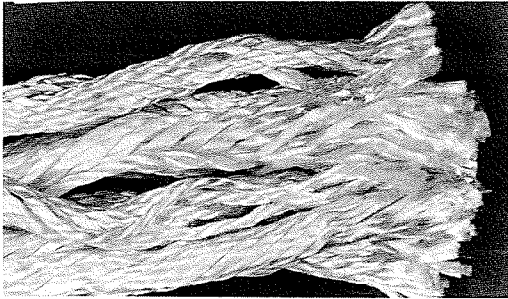

CAUSE OF DAMAGE — POCKET KNIFE

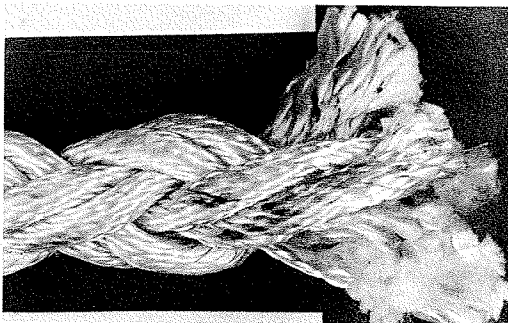

CAUSE OF DAMAGE — WIRE CUTTER

CONDITION OF ALL SAMPLES WHEN DAMAGED —
DRY; NO TENSILE LOAD

Figure 2.20

MACROSCOPIC

Yarn ends are cleanly cut to approximately the same length.

Rope end uneven. Ends of yarns tend to be fuzzy.

MICROSCOPIC

Most fiber ends show distortion in the direction of travel of the knife blade and appear to be Shear cut.

Predominant end types -

Ave. of 5 fiber samples

17% Sharp cut

82% Shear cut

Ends of fibers markedly distorted, bent in the direction of Shear, and many are Torn.

Predominant end types -

Ave. of 5 fiber samples

84% Shear cut

13% Torn

NYLON

MACROSCOPIC

MICROSCOPIC

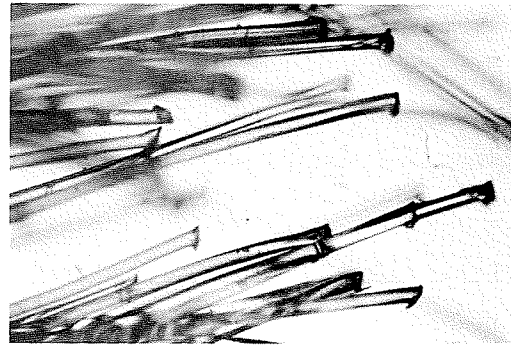
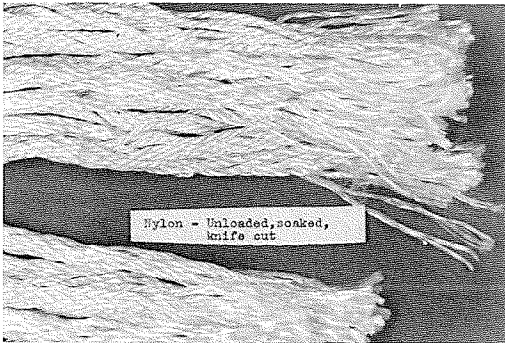

CAUSE OF DAMAGE — POCKET KNIFE

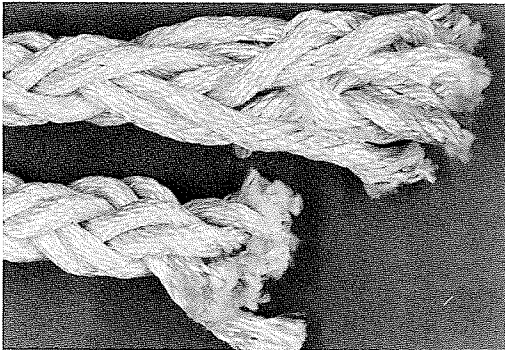

CAUSE OF DAMAGE — WIRE CUTTER

CONDITION OF ALL SAMPLES WHEN DAMAGED —
WATER SATURATED; NO TENSILE LOAD

Figure 2.21

MACROSCOPIC

Parted ends of yarn are of uneven lengths and fuzzy. Abraded lines may have discoloration, such as iron rust, from abrading surface.

Broken yarns of uneven length; ends fuzzy.

MICROSCOPIC

A mixture of Shear cut, Fractured, and Torn fiber ends.
Predominant end types -
Ave. of 5 fiber samples
66% Shear cut
23% Torn

Ends of fibers appear to be shear cut and torn.
Predominant end types -
Ave. of 5 fiber samples
23% Shear cut
65% Torn

NYLON

MACROSCOPIC

MICROSCOPIC

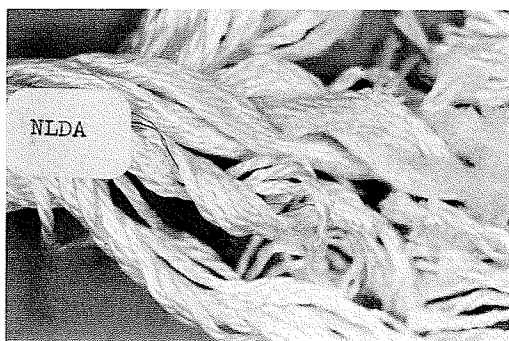

CAUSE OF DAMAGE — ABRASION WHEN DRY

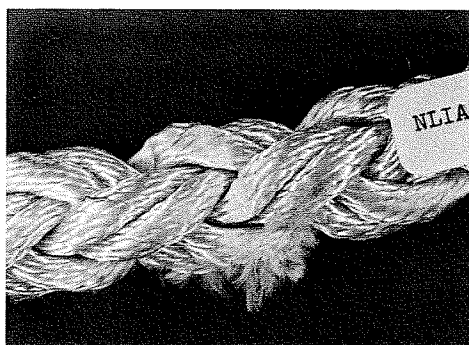

CAUSE OF DAMAGE — ABRASION WHEN IMMERSSED IN SEA WATER

CONDITION OF ALL SAMPLES WHEN DAMAGED —
1,000 POUNDS OF TENSILE LOAD

Figure 2.22

MACROSCOPIC

Broken end uneven. Evidence of recoil in line adjacent to the break. Yarn ends fuzzy.

Broken end is very uneven. Fibers in yarns tend to pull out to a "pony tail" appearance. Fibers and yarns may be stuck together.

Broken end very uneven and fuzzy. Fibers and yarns may be stuck together.

MICROSCOPIC

Fiber ends are contorted from recoil. Most appear to be fused.

Predominant end types -
Ave. of 5 fiber samples
13% Shear cut
72% Fused

Most fiber ends appear to be fused; some torn. The photograph shows four fibers with fused ends stuck together. Predominant end types -
Ave. of 5 fiber samples
66% Fused
16% Torn

Note round, fused fiber ends. Predominant end types -
Ave. of 5 fiber samples
15% Shear cut
70% Fused

NYLON

MACROSCOPIC

MICROSCOPIC

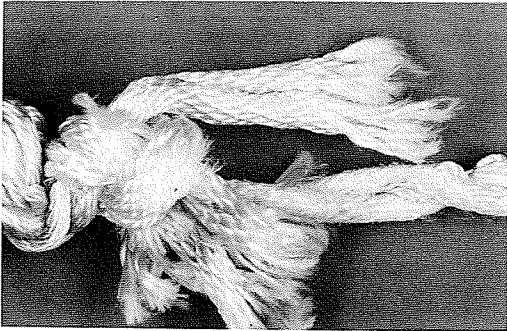

CAUSE OF DAMAGE — TENSION PULL WHEN DRY

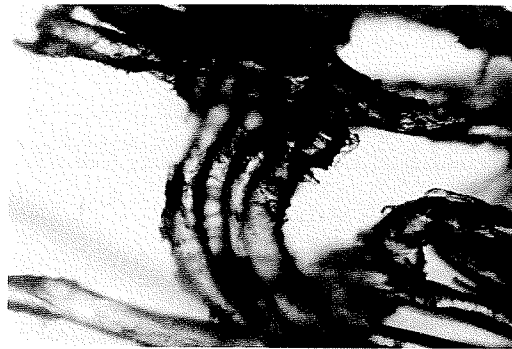
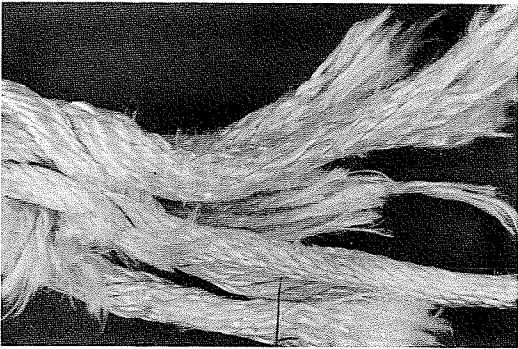

CAUSE OF DAMAGE — TENSION PULL WHEN WATER SATURATED

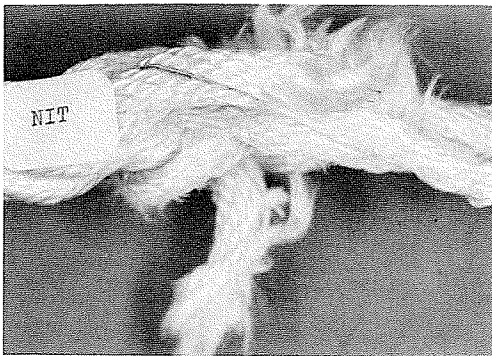

CAUSE OF DAMAGE — TENSION PULL WHEN IMMERSSED IN WATER

ALL SAMPLES PULLED UNTIL TOTAL FAILURE

Figure 2.23

MACROSCOPIC

Cut end of line is uneven and there are two principal sites of cutting due to spacing of teeth and disturbance of rope structure during cutting.

One strand cut has square end and is sharply cut.

Yarns are cleanly cut at two locations probably due to release of tension during cutting.

MICROSCOPIC

The fiber end shown is a Sharp cut end typical of fishbite.
Predominant end types -
Ave. of 5 fiber samples
70% Sharp cut
16% Shear cut

The fiber end shown is Sharp cut, typical of a cut with a very sharp edge.
Predominant end types -
Ave. of 5 fiber samples
71% Sharp cut
11% Shear cut
18% Split

The fiber end shown is Sharp cut and Split.
Predominant end types -
Ave. of 5 fiber samples
71% Sharp cut
13% Split

POLYPROPYLENE

MACROSCOPIC

MICROSCOPIC

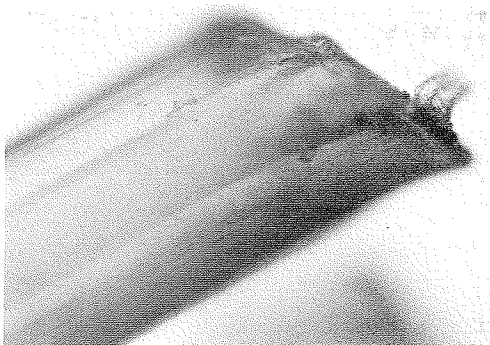
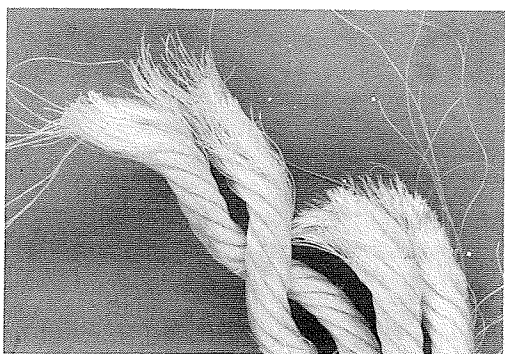

CAUSE OF DAMAGE — SHARK TEETH

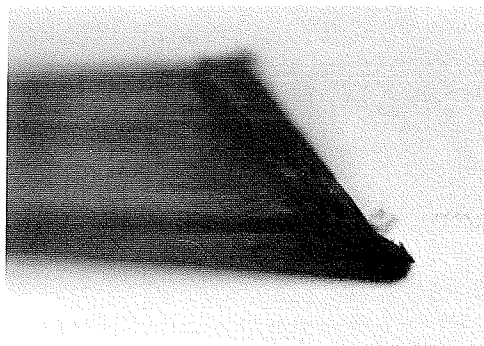

CAUSE OF DAMAGE — UTILITY KNIFE BLADE

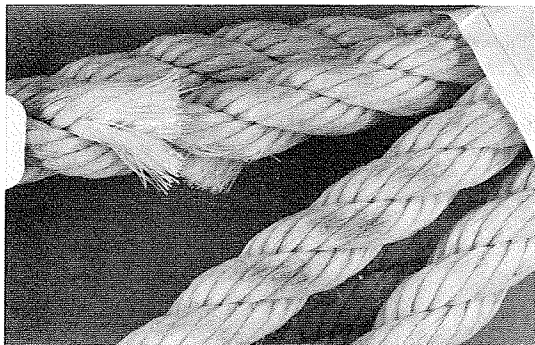

CAUSE OF DAMAGE — POCKET KNIFE

CONDITION OF ALL SAMPLES WHEN DAMAGED —
IMMERSED IN SEA WATER; 1,000 POUNDS OF TENSILE LOAD

Figure 2.24

MACROSCOPIC

End of line is squarely cut with the majority of fibers the same length.

Ends of strands squarely cut off. They tend to be fuzzy.

MICROSCOPIC

The fibers shown are sharply cut. One end is split due to friction or snagging of the knife blade.

Predominant end types -
Ave. of 5 fiber samples
44% Sharp cut
38% Shear cut
11% Split

The fiber ends shown are Shear cut.

Predominant end types -
Ave. of 5 fiber samples
57% Shear cut
14% Fractured
16% Torn

POLYPROPYLENE

MACROSCOPIC

MICROSCOPIC

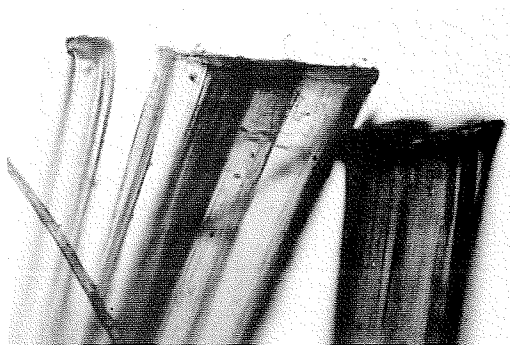
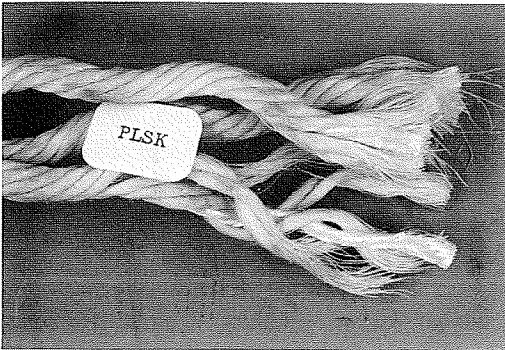

CAUSE OF DAMAGE — POCKET KNIFE

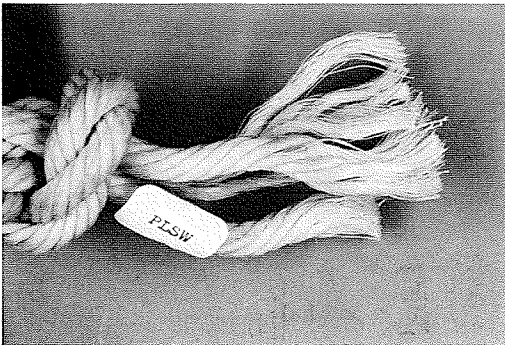

CAUSE OF DAMAGE — WIRE CUTTER

CONDITION OF ALL SAMPLES WHEN DAMAGED —
WATER SATURATED; 1,000 POUNDS OF TENSILE LOAD

Figure 2.25

MACROSCOPIC

Yarn ends contain fibers of slightly different lengths as are the strands.

The end of the rope is squarely cut with a tendency to be fuzzy.

MICROSCOPIC

Ends of fibers shown are quite sharply cut with some distortion and splitting in the direction of passage of the knife blade.

Predominant end types -
Ave. of 5 fiber samples
31% Sharp cut
65% Shear cut

Fiber ends shown are typically Shear cut.

Predominant end types -
Ave. of 5 fiber samples
72% Shear cut
11% Torn

POLYPROPYLENE

MACROSCOPIC

MICROSCOPIC

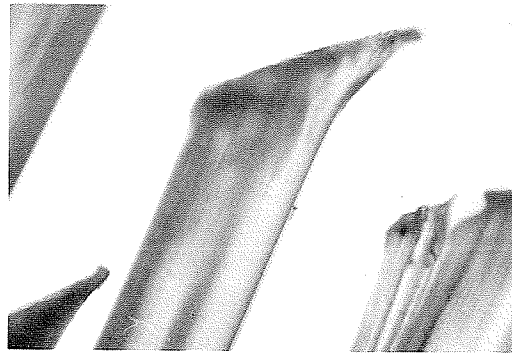
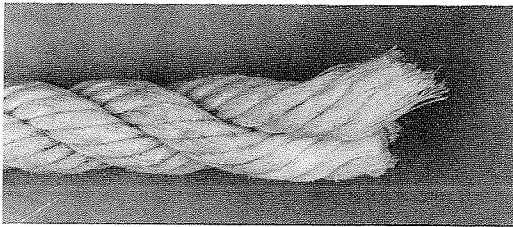

CAUSE OF DAMAGE — POCKET KNIFE

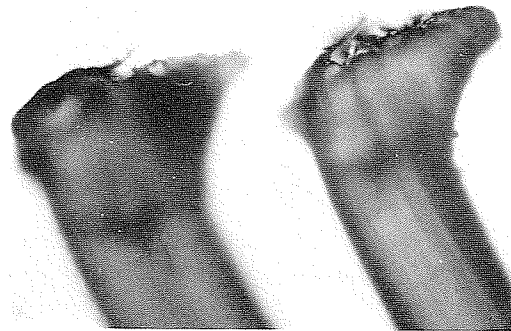
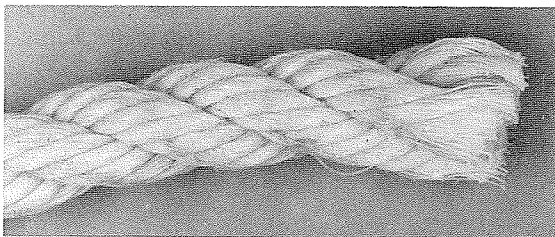

CAUSE OF DAMAGE — WIRE CUTTER

CONDITION OF ALL SAMPLES WHEN DAMAGED —
DRY; NO TENSILE LOAD

Figure 2.26

MACROSCOPIC

Ends of strands are cleanly cut but slightly uneven, probably due to untwisting of the severed end.

Cut ends of the line are squarely cut and slightly fuzzy.

MICROSCOPIC

The ends of the fibers shown are slightly distorted in the direction of travel of the knife blade and show a little roughness due to the condition of the blade edge.

Predominant end types -

Ave. of 5 fiber samples

42% Sharp cut

53% Shear cut

The one fiber end shown is a typically Shear cut end reflecting the relatively dull edge of the wire cutter cut blades.

Predominant end types -

Ave. of 5 fiber samples

86% Shear cut

POLYPROPYLENE

MACROSCOPIC

MICROSCOPIC

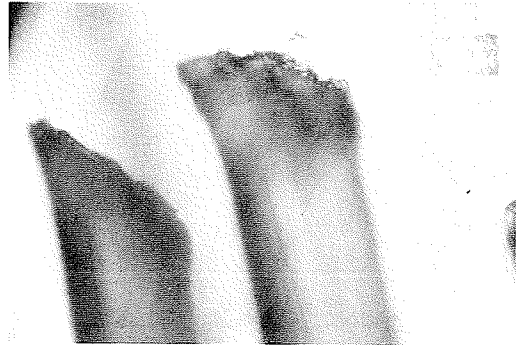
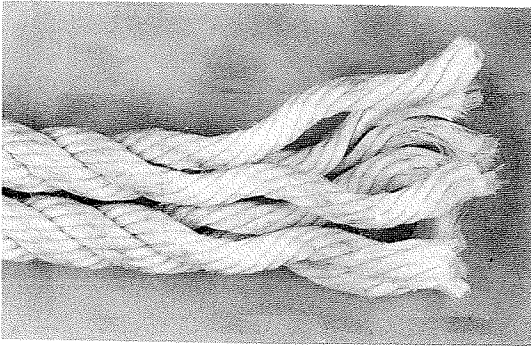

CAUSE OF DAMAGE — POCKET KNIFE

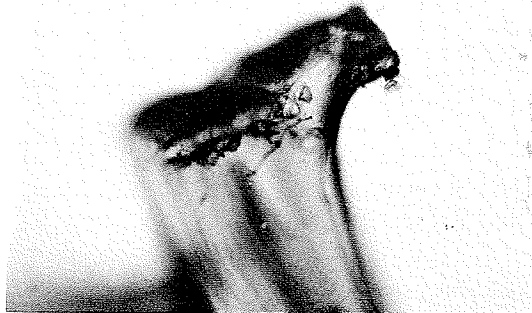
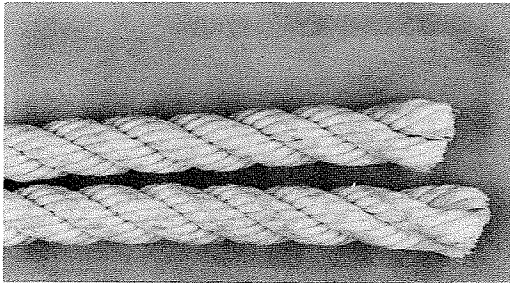

CAUSE OF DAMAGE — WIRE CUTTER

CONDITION OF ALL SAMPLES WHEN DAMAGED —
WATER SATURATED; NO TENSILE LOAD

Figure 2.27

MACROSCOPIC

Ends of fibers somewhat variable
in length and fuzzy.

Area of abrasion shows broken
yarns with fuzzy ends.

MICROSCOPIC

The fiber ends shown are Torn.
Predominant end types -

Ave. of 5 fiber samples
16% Shear cut
36% Fractured
16% Split
28% Torn

The fiber end shown is Torn.
Predominant end types -

Ave. of 5 fiber samples
91% Torn

POLYPROPYLENE

MACROSCOPIC

MICROSCOPIC

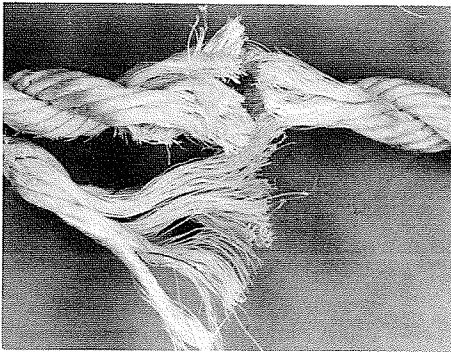

CAUSE OF DAMAGE — ABRASION WHEN DRY

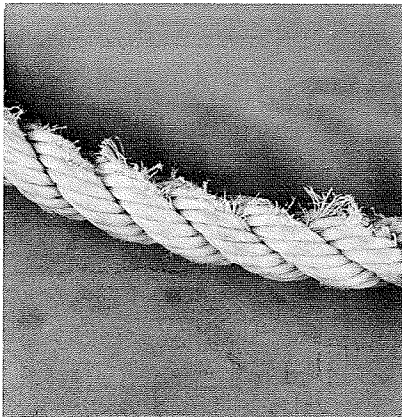

CAUSE OF DAMAGE — ABRASION WHEN IMMERSSED IN SEA WATER

CONDITION OF ALL SAMPLES WHEN DAMAGED —
1,000 POUNDS OF TENSILE LOAD

Figure 2.28

MACROSCOPIC

Broken end is uneven and rope structure shows recoil when broken.

Fiber and yarn ends are of varying lengths and rope structure disturbed by recoil.

Ends of yarns are variable in length and rope structure shows effects of recoil after break.

MICROSCOPIC

The end of the fiber shown is Fused and Fractured.

Predominant end types -

Ave. of 5 fiber samples

47% Fused

33% Fractured

The fiber end shown is Fractured.

Predominant end types -

Ave. of 5 fiber samples

28% Shear cut

33% Fractured

28% Split

Fiber end shown is Torn and Split.

Predominant end types -

Ave. of 5 fiber types

58% Fractured

22% Split

13% Torn

POLYPROPYLENE

MACROSCOPIC

MICROSCOPIC

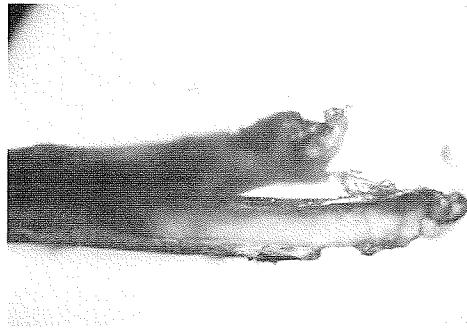
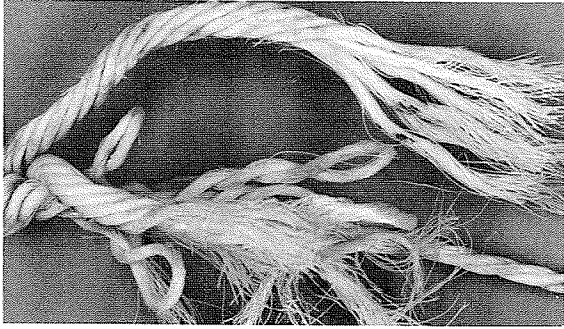

CAUSE OF DAMAGE - TENSION PULL WHEN DRY

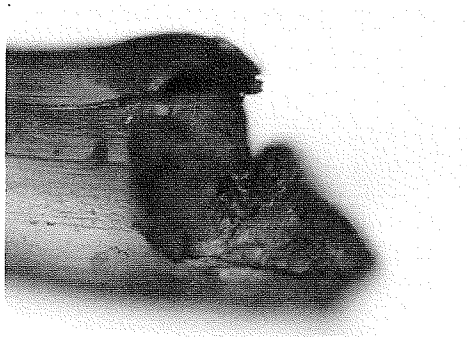
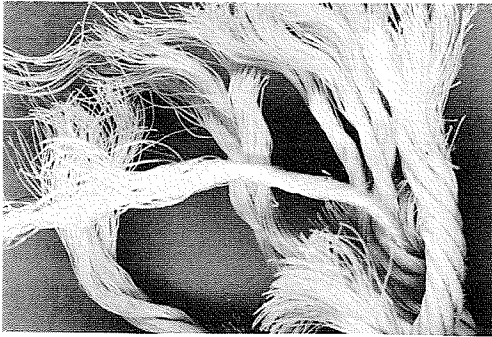

CAUSE OF DAMAGE - TENSION PULL WHEN WATER SATURATED

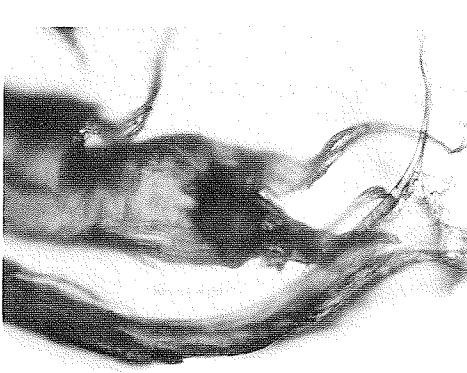
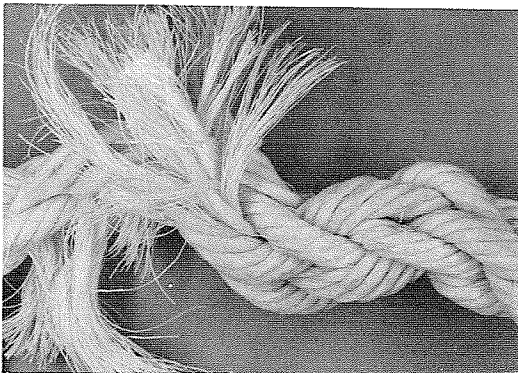

CAUSE OF DAMAGE - TENSION PULL WHEN IMMERSSED IN WATER

ALL SAMPLES PULLED UNTIL TOTAL FAILURE

Figure 2.29

MACROSCOPIC

Yarn ends are cleanly cut but of uneven length.

Yarns cleanly but only partially cut.

Yarns are squarely and cleanly cut and all about the same length.

MICROSCOPIC

Almost all of the fiber ends shown are Sharp cut. A few are slightly distorted in the direction of movement of the teeth which cut them.

Predominant end types -

Ave. of 5 fiber samples

48% Sharp cut

26% Shear cut

10% Split

The fiber ends shown are Torn.

Predominant end types -

Ave. of 5 fiber samples

43% Shear cut

49% Torn

Fiber ends shown in the photograph are Shear cut and Torn.

Predominant end types -

Ave. of 5 fiber samples

13% Sharp cut

65% Shear cut

17% Torn

KEVLAR

MACROSCOPIC

MICROSCOPIC

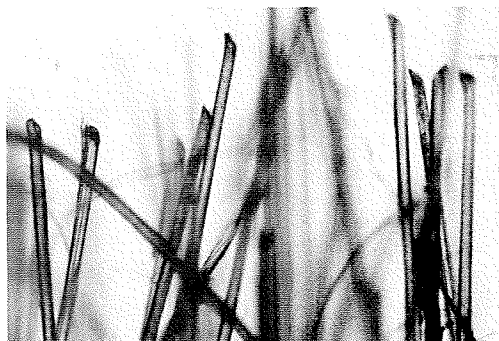
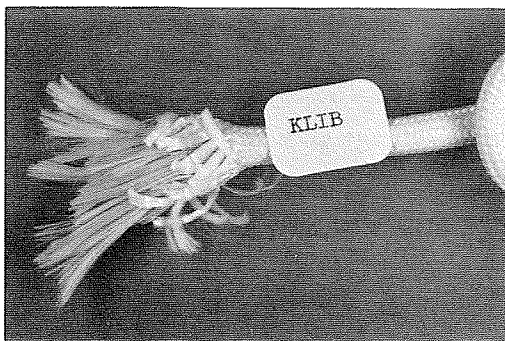

CAUSE OF DAMAGE — SHARK TEETH

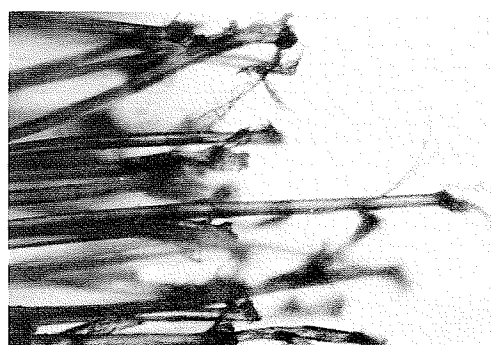
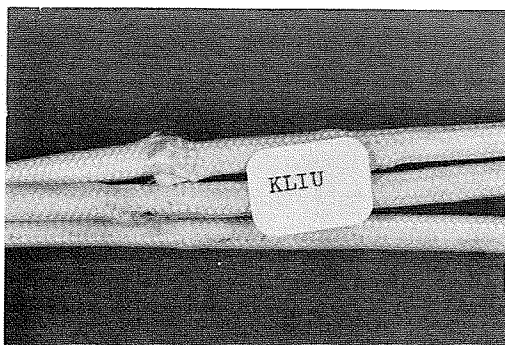

CAUSE OF DAMAGE — UTILITY KNIFE BLADE

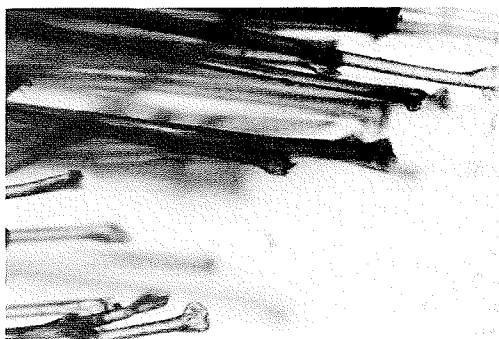
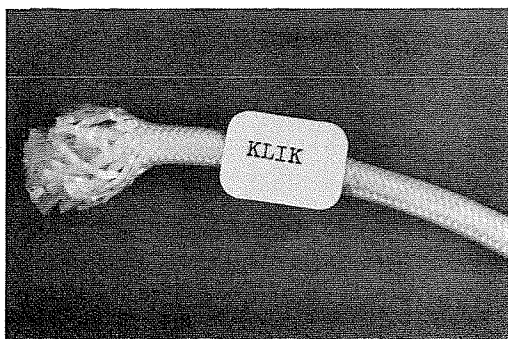

CAUSE OF DAMAGE — POCKET KNIFE

CONDITION OF ALL SAMPLES WHEN DAMAGED —
IMMERSED IN SEA WATER; 1,000 POUNDS OF TENSILE LOAD

Figure 2.30

MACROSCOPIC

End of rope cleanly and squarely cut off. A few fibers apparently broken by tension to produce a minute "pony tail."

Cut end of rope is fuzzy.

MICROSCOPIC

Fiber ends shown are mainly Shear cut.

Predominant end types -

Ave. of 5 fiber ends

56% Shear cut

12% Split

22% Torn

Ends of fibers shown are mangled and tangled.

Predominant end types -

Ave. of 5 fiber samples

20% Shear cut

51% Torn

KEVLAR

MACROSCOPIC

MICROSCOPIC

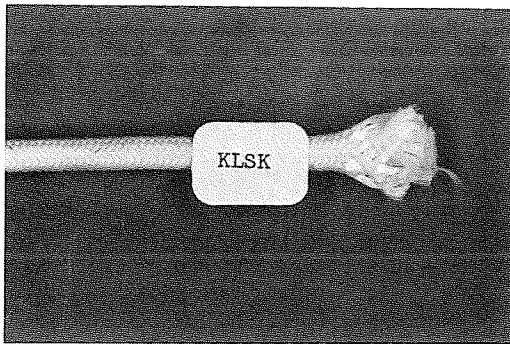

CAUSE OF DAMAGE - POCKET KNIFE

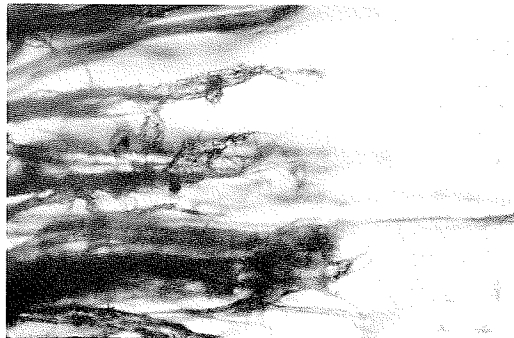
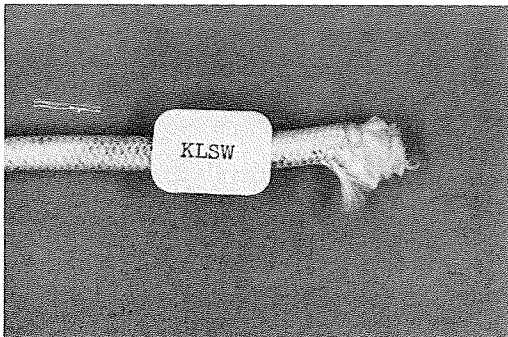

CAUSE OF DAMAGE - WIRE CUTTER

CONDITION OF ALL SAMPLES WHEN DAMAGED -
WATER SATURATED; 1,000 POUNDS OF TENSILE LOAD

Figure 2.31

MACROSCOPIC

Ends of yarns appear to be cut
off to slightly varying lengths.

End of line squarely cut off.

MICROSCOPIC

Fiber ends photographed are
Shear cut.

Predominant end types -
Ave. of 5 fiber samples
80% Shear cut

Ends of fibers shown are torn
and tangled.

Predominant end types -
Ave. of 5 fiber samples
72% Shear cut
9% Torn

KEVLAR

MACROSCOPIC

MICROSCOPIC

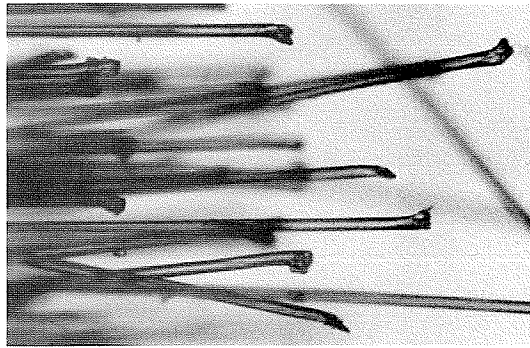
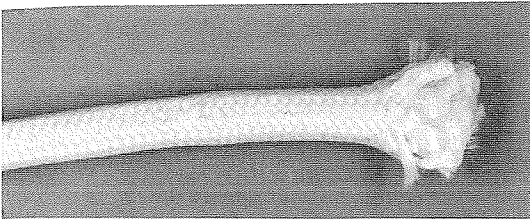

CAUSE OF DAMAGE — POCKET KNIFE

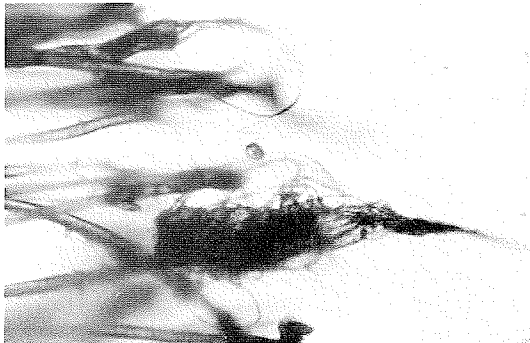
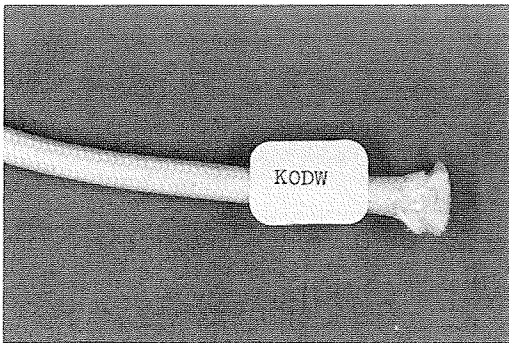

CAUSE OF DAMAGE — WIRE CUTTER

CONDITION OF ALL SAMPLES WHEN DAMAGED —
DRY; NO TENSILE LOAD

Figure 2.32

MACROSCOPIC

Rope squarely cut off.

Rope end squarely cut but with a tendency to be fuzzy. Rust marks near the cut end are characteristic of cut with a tool used around salt water.

MICROSCOPIC

Fiber ends in the photograph are all Shear cut.

Predominant end types -

Ave. of 5 fiber samples
96% Shear cut

Fiber ends are Shear cut and Torn.

Predominant end types -

Ave. of 5 fiber samples
75% Shear cut
15% Torn

KEVLAR

MACROSCOPIC

MICROSCOPIC

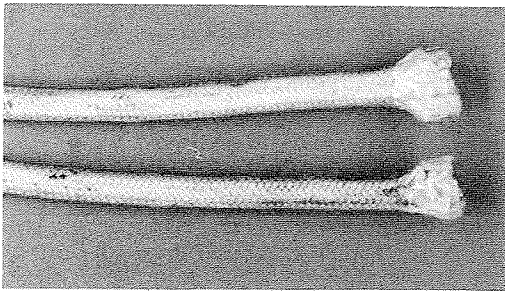

CAUSE OF DAMAGE — POCKET KNIFE

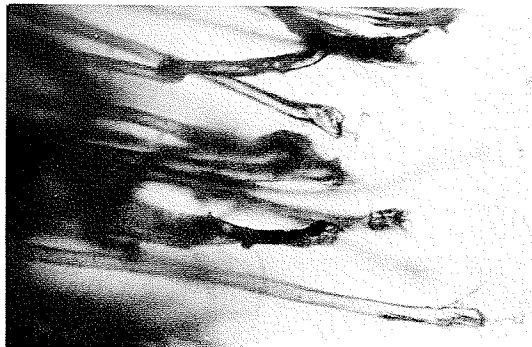
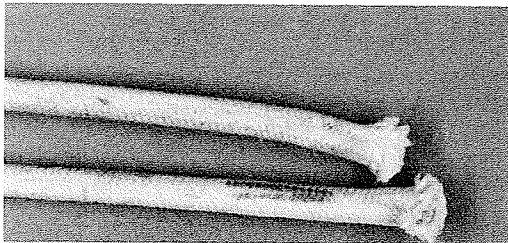

CAUSE OF DAMAGE — WIRE CUTTER

CONDITION OF ALL SAMPLES WHEN DAMAGED —
WATER SATURATED; NO TENSILE LOAD

Figure 2.33

MACROSCOPIC

The area of damage is rough and fuzzy.

The area of damage is rough and fuzzy.

MICROSCOPIC

Ends of fibers shown mostly Torn.

Predominant end types -

Ave. of 5 fiber samples

14% Fractured

15% Split

56% Torn

Ends of fibers shown are Torn and Split.

Predominant end types -

Ave. of 5 fiber samples

28% Shear cut

11% Fractured

23% Split

27% Torn

KEVLAR

MACROSCOPIC

MICROSCOPIC

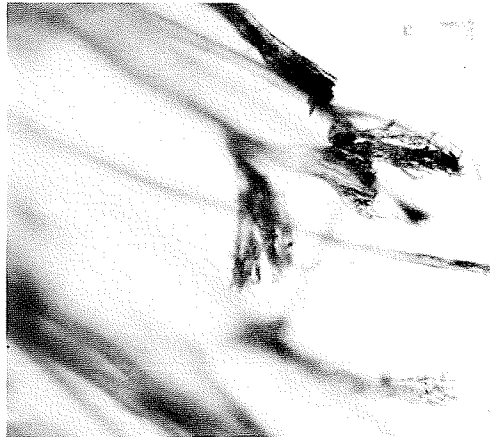
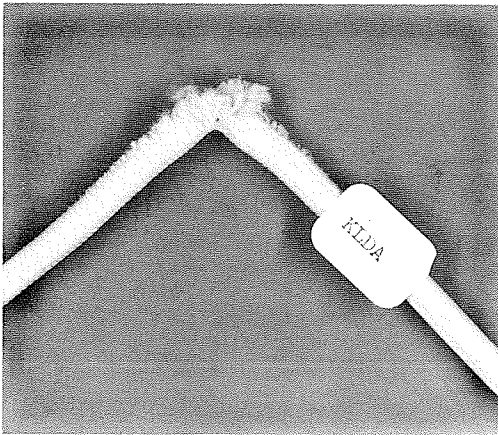

CAUSE OF DAMAGE — ABRASION WHEN DRY

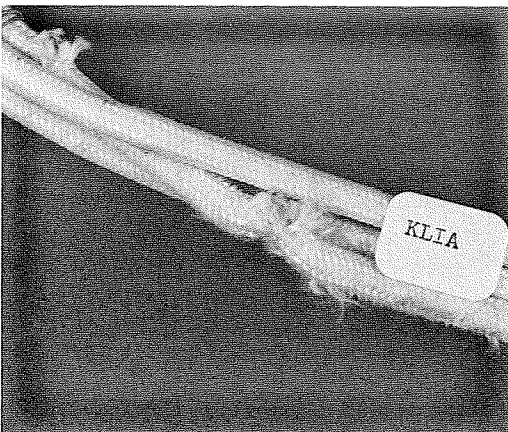

CAUSE OF DAMAGE — ABRASION WHEN IMMERSSED IN SEA WATER

CONDITION OF ALL SAMPLES WHEN DAMAGED —
1,000 POUNDS OF TENSILE LOAD

Figure 2.34

MACROSCOPIC

Ends of broken yarns are of uneven lengths and tend to be pulled out to a point.

Ends of broken yarns are of uneven length and drawn out to a point.

Some yarns have square ends, others have uneven ends.

MICROSCOPIC

Fiber ends are split and tangled.

Predominant end types -

Ave. of 5 fiber samples

11% Attenuated

81% Split

The photograph shows an Attenuated fiber.

Predominant end types -

Ave. of 5 fiber samples

22% Attenuated

66% Split

The fiber ends in the photograph are mostly Split with one or two Torn.

Predominant end types -

Ave. of 5 fiber samples

80% Split

9% Torn

KEVLAR

MACROSCOPIC

MICROSCOPIC

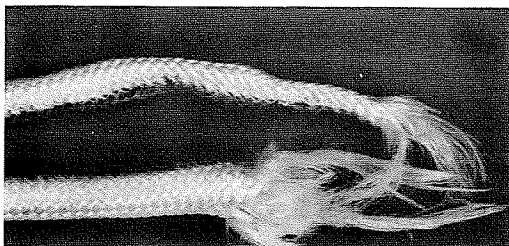

CAUSE OF DAMAGE — TENSION PULL WHEN DRY

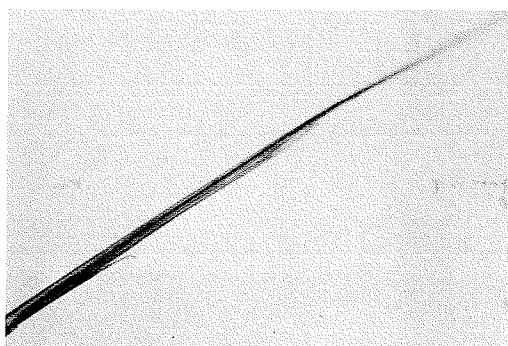
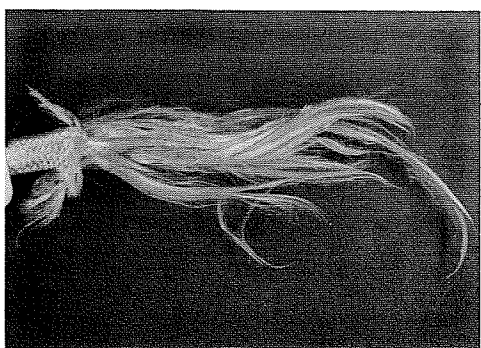

CAUSE OF DAMAGE — TENSION PULL WHEN WATER SATURATED

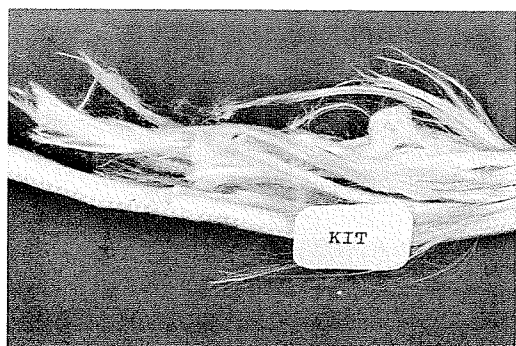

CAUSE OF DAMAGE — TENSION PULL WHEN IMMERSSED IN WATER

ALL SAMPLES PULLED UNTIL TOTAL FAILURE

Figure 2.35

PERCENTAGE DISTRIBUTION

OF

FIBER END APPEARANCES

POLYESTER	PAGE	82
NYLON	PAGE	83
POLYPROPYLENE	PAGE	84
KEVLAR	PAGE	85

ROPE MATERIAL : POLYESTER									
CAUSE OF DAMAGE	CONDITION OF SAMPLE	APPEARANCE OF FIBER ENDS							
		SHARP CUT	SHEAR CUT	FUSED	ATTEN- UATED	FRAC- TURED	SPLIT	TORN	OTHER
FISHBITE	IMMERSED (1000 lbs tension)	35	63	0	0	1	0	1	0
VERY SHARP CUT (utility knife, razor blade)	IMMERSED (1000 lbs tension)	29	65	1	0	2	0	3	0
CUT (pocket knife)	IMMERSED (1000 lbs tension)	25	66	3	0	2	0	3	1
	SATURATED (1000 lbs tension)	3	91	1	0	1	0	4	0
	SATURATED (no load)	11	88	0	0	0	0	0	0
	DRY (no load)	10	79	6	0	2	0	1	1
SHEAR CUT (wire cutter)	SATURATED (1000 lbs tension)	3	64	17	1	2	0	12	1
	SATURATED (no load)	3	90	1	1	1	0	4	1
	DRY (no load)	3	79	6	1	4	0	6	1
TENSION PULL TO BREAK	IMMERSED	4	14	32	1	37	0	11	1
	SATURATED	6	33	51	1	3	0	4	2
	DRY	3	25	55	1	9	0	4	2
ABRASION	IMMERSED (1000 lbs load)	18	36	4	2	15	0	26	4
	DRY (1000 lbs load)	0	66	2	1	3	0	27	1

Figure 2.36 Percentage distribution of fiber end appearances as a function of damage causes and sample conditions.

ROPE MATERIAL : NYLON									
CAUSE OF DAMAGE	CONDITION OF SAMPLE	APPEARANCE OF FIBER ENDS							
		SHARP CUT	SHEAR CUT	FUSED	ATTEN- UATED	FRAC- TURED	SPLIT	TORN	OTHER
FISHBITE	IMMERSED (1000 lbs tension)	64	26	2	0	2	0	4	1
VERY SHARP CUT (utility knife, razor blade)	IMMERSED (1000 lbs tension)	48	50	1	0	0	0	1	0
CUT (pocket knife)	IMMERSED (1000 lbs tension)	24	67	2	0	1	0	5	1
	SATURATED (1000 lbs tension)	34	61	1	0	0	2	2	0
	SATURATED (no load)	17	82	0	0	0	0	0	0
	DRY (no load)	22	72	2	0	2	0	1	1
SHEAR CUT (wire cutter)	SATURATED (1000 lbs tension)	3	70	9	3	4	1	9	1
	SATURATED (no load)	0	84	0	1	1	0	13	0
	DRY (no load)	3	87	1	1	2	0	6	1
TENSION PULL TO BREAK	IMMERSED	1	15	70	2	7	0	6	1
	SATURATED	0	8	66	3	4	0	16	2
	DRY	2	13	72	2	6	0	5	0
ABRASION	IMMERSED (1000 lbs load)	1	23	3	1	5	0	65	1
	DRY (1000 lbs load)	3	66	2	1	5	0	23	1

Figure 2.37 Percentage distribution of fiber end appearances as a function of damage causes and sample conditions.

ROPE MATERIAL : POLYPROPYLENE									
CAUSE OF DAMAGE	CONDITION OF SAMPLE	APPEARANCE OF FIBER ENDS							
		SHARP CUT	SHEAR CUT	FUSED	ATTEN- UATED	FRAC- TURED	SPLIT	TORN	OTHER
FISHBITE	IMMERSED (1000 lbs tension)	70	16	0	0	6	7	0	0
VERY SHARP CUT (utility knife, razor blade)	IMMERSED (1000 lbs tension)	71	11	0	0	0	18	0	0
CUT (pocket knife)	IMMERSED (1000 lbs tension)	71	9	0	0	5	13	0	1
	SATURATED (1000 lbs tension)	44	38	0	0	3	11	3	1
	SATURATED (no load)	42	53	0	0	2	4	0	0
	DRY (no load)	31	65	1	0	3	0	1	1
SHEAR CUT (wire cutter)	SATURATED (1000 lbs tension)	2	57	4	4	14	3	16	1
	SATURATED (no load)	3	86	1	1	2	1	7	0
	DRY (no load)	8	72	0	0	8	0	11	1
TENSION PULL TO BREAK	IMMERSED	0	7	0	0	58	22	13	0
	SATURATED	1	28	2	2	33	28	3	2
	DRY	3	6	47	1	33	3	6	1
ABRASION	IMMERSED (1000 lbs load)	0	4	0	1	0	4	91	0
	DRY (1000 lbs load)	2	16	0	1	36	16	28	1

Figure 2.38 Percentage distribution of fiber end appearances as a function of damage causes and sample conditions.

ROPE MATERIAL : KEVLAR									
CAUSE OF DAMAGE	CONDITION OF SAMPLE	APPEARANCE OF FIBER ENDS							
		SHARP CUT	SHEAR CUT	FUSED	ATTEN- UATED	FRAC- TURED	SPLIT	TORN	OTHER
FISHBITE	IMMERSED (1000 lbs tension)	48	26	0	2	6	10	7	1
VERY SHARP CUT (utility knife, razor blade)	IMMERSED (1000 lbs tension)	0	43	0	1	4	1	49	1
CUT (pocket knife)	IMMERSED (1000 lbs tension)	13	65	0	0	4	1	17	1
	SATURATED (1000 lbs tension)	0	56	1	3	5	12	22	1
	SATURATED (no load)	2	96	0	0	0	0	1	0
	DRY (no load)	6	80	5	1	4	0	4	1
SHEAR CUT (wire cutter)	SATURATED (1000 lbs tension)	2	20	2	8	6	8	51	3
	SATURATED (no load)	1	75	1	1	2	4	15	1
	DRY (no load)	5	72	4	2	5	2	9	1
TENSION PULL TO BREAK	IMMERSED	0	0	0	7	4	80	9	1
	SATURATED	0	1	0	22	3	66	8	1
	DRY	0	0	0	11	1	81	6	0
ABRASION	IMMERSED (1000 lbs load)	1	28	1	7	11	23	27	3
	DRY (1000 lbs load)	0	8	0	5	14	15	56	1

Figure 2.39 Percentage distribution of fiber end appearances as a function of damage causes and sample conditions.

2.3.3.4. Interpretation of results. Having obtained a good set of macroscopic and microscopic observations, now the question of interpretation must be addressed. To ascertain if fishbite was the most probable cause of the line failure, the best approach is perhaps to first isolate the mode of failure, that is the manner in which the mechanical damage was inflicted. If no cutting is evident then fishbite a priori should not be considered as causative. On the other hand any positive indication of cutting should prompt further investigation to identify the instrument, including fish teeth, which destroyed the line integrity. Let us review this "two steps" approach in some detail.

Basically, there are three kinds of mechanical abuse which can result in line failure: cutting, tensile over stress, and abrasion. Combinations of these three modes may be present in severely abused ropes. The indicators for these three modes vary with fiber material and rope construction. In general however, there are features which can reliably be used to identify each mode as indicated below.

. Damage due to cutting - Ropes which have been cut characteristically have yarns with truncated, even, square ends. The cut yarns are usually found at the same location along the rope. Fiber ends in a cut rope are predominantly Sharp Cut and/or Shear Cut. Cuts which have been made by a keen edge will contain mostly Sharp Cut fiber ends. As progressively duller and more uneven edges are encountered, the percentage of Shear Cut ends increases, and some Torn fiber ends may be produced. Kevlar fibers also develop Split ends.

. Damage due to tensile overstress - If a failed rope shows structural change due to recoil, a significant part of its failure may have been due to a tensile overload. However, some lines such as one with a tensile

member of Kevlar which has a high tensile modulus and a cover of braided polyester which holds the line together may show little evidence of recoil following a sudden break.

Ropes broken by tension usually have very uneven ends. The individual yarn ends may be pointed and have a fuzzy appearance. Fibers, yarns, and even strands may be stuck together from fusion at the time of breaking. In the present series, polyester, nylon, and polypropylene show this effect. Kevlar does not.

Under the microscope, the most characteristic feature of fibers broken by tension is fusion. Again, polyester, nylon, and polypropylene fibers have evidence of fusion which appears as rounded ends. The Kevlar fibers have split ends. In addition to fusion, it will be noted from Figures 2.36, 2.37, 2.38, and 2.39 that there is a scattering of other fiber end appearances produced from a tension break.

Inasmuch as the primary function of most ropes is to carry a tensile load, there is usually some indication of this type of failure in lines where the primary damage was cutting or abrasion followed by final parting due to tensile overload on the remaining yarns.

. Damage due to abrasion - Abrasive damage may be localized or it may be spread over a long stretch. The damage area appears fuzzy and contains many tangled fiber ends. Sometimes there is discoloration of the rope brought about by the abrading surface. Presence of iron rust, paint, grease is common. Microscopically, the outstanding feature is Torn and Sheared fiber ends. There is usually a variety of less abundant fiber end appearances including Fractured and Split ends. Sharp Cut fiber ends are notably absent from most lines damaged by abrasion.

Table 2.2 is a synopsis of laboratory observations for use in identifying these three kinds of mechanical damage.

Table 2.2
Identification of principal failure modes in
Synthetic fiber ropes

Observations		Indicated
Macroscopic	Microscopic	Mode of Failure
Most yarn ends are squarely and cleanly cut off at about the same length. Sometimes cut yarn ends may be seen sticking out the sides of a partially severed line.	Majority of Sharp Cut and Shear Cut fiber ends. Kevlar is likely to have some Split and Torn ends in addition. Split and Torn ends increase as cutting edge is dull or rough.	Cutting
Yarn ends of varied length, pointed, may be fuzzy. Rope structure shows evidence of recoil and sticking together of yarns and fibers.	Fiber end types mixed. Fused most characteristic except for Kevlar which has a majority of Split ends.	Tensile overstress
Rope structure disturbed at site of damage but no recoil. Damage area is fuzzy and in some cases strung out along the line. May have discoloration. Presence of rust or grease.	A mixture of end types Torn and Shear Cut ends most characteristic. Sharp Cut ends are absent.	Abrasion

If it has been determined that cutting, especially cutting by a very sharp edge, is an important factor in the failure of a mooring line, the possibility of fishbite should be considered next. If teeth or tooth fragments are found in the damaged area, then the cause of failure most probably is fishbite. Most of the time no teeth are to be found. The next step is then to see if the cut fiber end appearances are characteristic of fishbite.

Experience to date indicates that fish teeth can produce cuts which would be expected from only the sharpest of cutting edges. Hence a suspicion of fishbite is aroused when a large proportion of very neatly cut fiber ends are seen under the microscope. If the data from a cut line falls within the limits shown in Table 2.3, fishbite is a possibility.

Table 2.3
Probability that line cutting was due to Fishbite

Cut End Appearance	Percentage of Fiber Ends	
	Sharp Cut	35 % or more
Fused	None	10% or more
Torn	10% or less	25% or more
	Consistent with a finding of fishbite	Probably not fishbite

If the cut end appearances reveal that the cut is most likely NOT fishbite, then other causes of damage must be investigated using standards of comparison and any available circumstantial evidence. Because other forms of cutting (sharp blade, glass edge, etc...) may produce similar percentages of sharp cut appearances, the probability of fishbite attacks must be corroborated with additional findings. One confirming factor can be the manner in which cuts occur in the rope. A rope damaged by fishbites will show some of the following characteristic patterns:

- a) Paired cuts a few centimeters apart. Caused by teeth on opposite sides of a jaw.
- b) Cuts separated only by one or two centimeters due to adjacent teeth on one side of a jaw.

- c) Cuts on both sides of the rope due to upper and lower jaw teeth.
- d) Other cuts, meters away from the severed end, indicative of additional bites.

In short, if the cuts are very sharp and their spacing commensurate with known tooth arrangements and jaw dimensions, then the probability of fishbite is very good. On the other hand, the case of the "single" cut is more enigmatic.

If the "single" cut is clean across the rope then the probability of cuts other than fishbite exists. Perhaps the rope was deliberately hauled and cut, perhaps it was accidentally cut over a sharp edge, a broken glass float for example. Documentary evidence, records, depth at which cut was made would greatly help confirm the suspicion. Without this however, it may be impossible to differentiate between natural (fish attack) and artificial (man made) cause of failure.

If the "single" cut is a partial cut followed by a tensile break then chances are good that the line was damaged while in service, most likely while on station. In this case fishbite becomes the prime suspect again. Circumstantial evidence which reinforces this conviction would include noticeable fish activity at the time of deployment or recovery, and line breakage while on station which cannot be linked to severe environment conditions (storm, high currents, etc...).

Rope cuts occurring at depths or geographical locations (see Chapter 3) where fishbites are unlikely to occur are difficult to explain. In these cases the possibility of the rope being cut prior to deployment, or during deployment should seriously be considered. The quintessence of the interpretation process just reviewed is graphically represented in the flowchart shown in Figure 2.40.

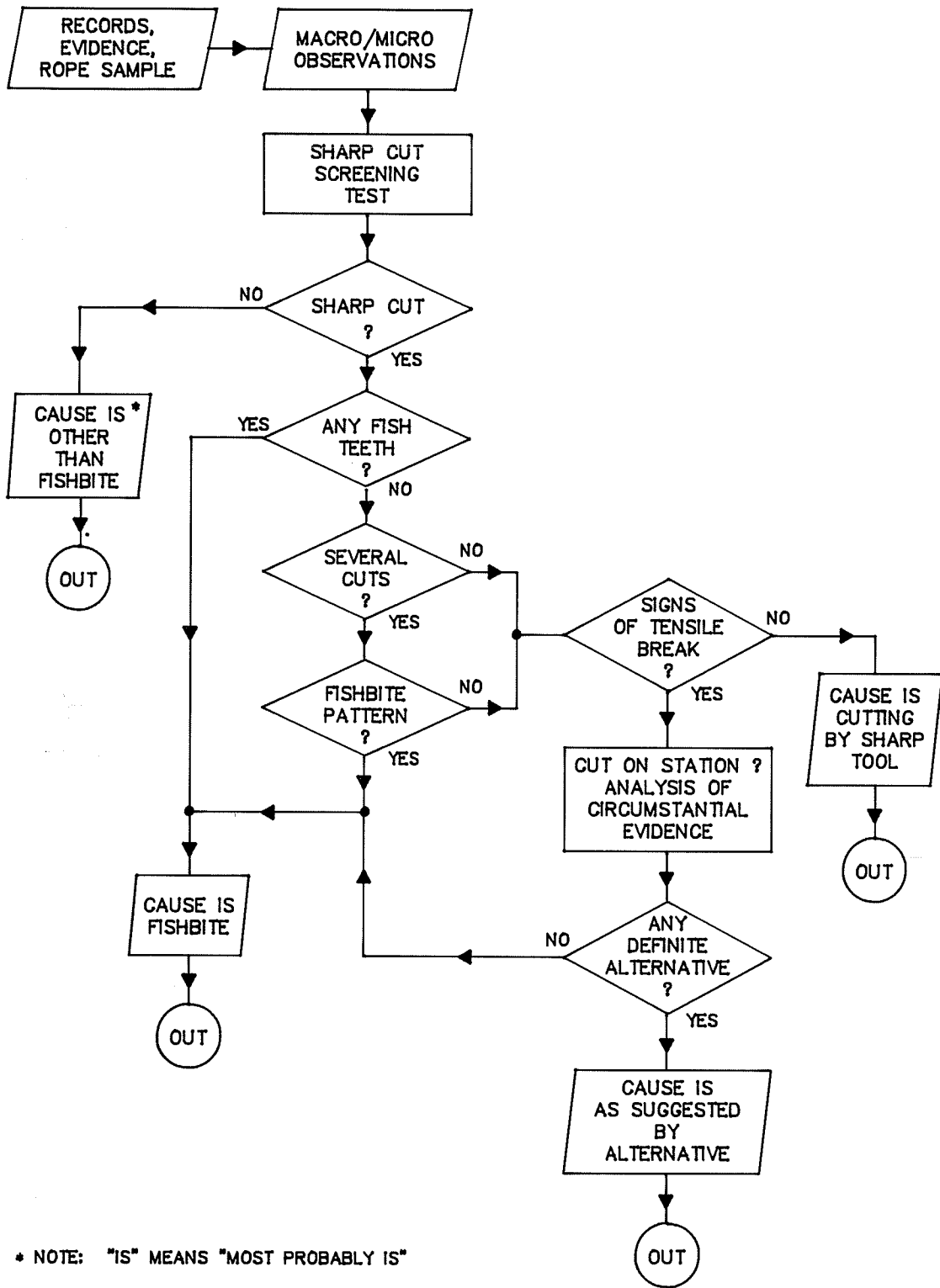

Figure 2.40 Fishbite Identification Flow Chart.

2.4. Conclusion.

To conclude, fishbites are relatively easy to locate and identify in plastic covered metallic and non-metallic cables and ropes. The traces or markings left by the teeth and sometimes the teeth or tooth fragments embedded in the jacket have been used to identify the aggressors and characterize the patterns of damage.

Fishbite damage in unprotected fiber ropes is more difficult to positively identify. A screening test must confirm that a sufficient percentage of the fibers have been "clean" cut. When this is the case the possibility of fishbites must be further confirmed by presence of teeth, or patterns of cuts, or direct evidence, or by elimination of other possible alternatives.

Fishbite identification still remains a patient art. Statistical evaluation of microscopic observations done on well prepared specimen is an essential tool for a rational interpretation of failure causes.

CHAPTER 3 - DIMENSION OF THE FISHBITE PROBLEM

Fishbite on deep sea lines is not uniformly encountered either in terms of space or time. With reference to the former, there appear to be places where risk is negligible. In other cases, it is a predictable phenomenon, and the purpose of this chapter of the Handbook is to provide a background for use in estimating fishbite hazard.

3.1. Study of fishbites on a large sample of oceanic moorings.

Given a number of moored stations, what percentage of mooring lines might one expect to be bitten? What are the relationships between fishbite and such factors as geographical location, depth of water, surface vs. subsurface floats, and the service life of a mooring?

In an attempt to find quantitative answers to such questions, data from 550 moored stations deployed by the Woods Hole Oceanographic Institution from 1967 to 1985 were assembled and analyzed, correlating incidence of fishbite with:

Depth of buoy

Geographical location (site)

Depth of water at the mooring site (bottom depth)

Duration of moored station

Depth of occurrence at a single location

Depth of occurrence worldwide

3.1.1. Procedure for establishing fishbite data.

Log sheets of WHOI's moored stations were reviewed and data relative to fishbite tabulated for the years since 1967. 1967 was chosen as the

starting year because it was the first year when fishbite observations were made on a routine basis. The dates given for moorings are the dates of deployment. Moorings set each year are grouped together regardless of date of recovery.

Fishbite data have been reduced to "+", line bitten or "0", line not bitten, regardless of the number of bites found on any individual mooring line. It has been assumed that all lines were examined for evidence of fishbite and that in each case where typical damage was found a record of fishbite was made. In the cases of all other station logs, whether the record indicated a search for fishbite with negative results, or where a log contained no reference to fishbite, it has been assumed that the line was not bitten. Such a method may not lead to working figures which contain a record of every contact between lines and fish teeth. However, it would seem to be in line with practical considerations which govern the use of obviously damaged lines.

The fishbite data were recorded by personnel who happened to be aboard ship at the time of hauling. Hence, many observers with varied experience in detecting fishbite and often under pressure of other duties were involved. In the writer's experience, observers working under shipboard conditions usually do not find as many bites as a later, detailed examination of a line in the laboratory will reveal. The number of fishbites reported in the log sheets is therefore regarded as conservative.

3.1.2. Ocean areas included in the study.

431 or 78% of all moored stations in the study were deployed in the North Atlantic Ocean. The rest were placed: 32 in the Pacific Ocean

between the Aleutian Islands and Hawaii, 4 in the Philippine Sea, 15 in the Indian Ocean, 21 in the North Pacific near Japan, 30 in the North Pacific near the United States, 10 in the South Atlantic, 5 near Gibraltar, and 1 in the Pacific Ocean near Panama. In terms of world ocean space, therefore, the representation of data is predominately from the Atlantic Ocean north of the Equator. What follows by way of interpretation of the data can be applied to that area with some degree of confidence. With reference to other parts of the world's oceans, conclusions can only be tentative until more uniform coverage has been obtained.

Of the total number of stations, 385 or 70% were located in what will hereinafter be designated as the "Fishbite Zone." It is an ocean space bounded by latitude and by depth. It lies between 40° north and 40° south latitude. The depth boundaries are between the water-air interface and 2000 meters below the surface. These boundaries are based upon experience gained from deep sea moorings observations as reported in "Deep-Sea Lines Fishbite Manual" (Prindle and Walden, 1975).

In the time period covered in the present report, 36 WHOI buoys were deployed outside the area bounded by the 40° north and south parallels. Data for these moorings are presented in Table 3.1. Of the 36 only 19 were recorded to be within the depth limit of the Fishbite Zone. Of these 19 only 2 did show signs of fish attacks. This result supports the use of 40° latitude as a boundary for the Fishbite Zone, but more information from the Southern Hemisphere is needed.

With reference to depth, 116 moored arrays were placed inside the 40° parallels but with all components at depths greater than 2000 meters. Of these, none were reported bitten.

Table 3.1

WHOI Stations Moored Above 40°N Latitude

Year Set	Station #	Buoy Depth Meters	Latitude	Longitude	Water Depth m	Duration Days	Bites
1967	257	0	43.00	70.43	104	1	none
1969	321	3	41.52	70.65	27	14	"
1970	337	7	41.43	70.77	26	1	"
1972	445	5107	40.06	49.84	5384	53	"
"	446	3966	40.56	49.75	4244	53	"
"	447	3405	41.00	49.77	3683	52	"
"	448	2741	41.50	49.73	3018	52	"
1975	560	3137	41.48	54.98	4774	215	"
"	561	2932	40.47	55.02	5171	217	"
"	570	4190	52.71	33.99	4288	272	"
"	571	970	52.90	39.52	2895	273	"
"	572	956	52.77	35.50	3398	273	"
"	573	3962	41.49	54.98	4758	306	"
"	574	3966	40.45	55.05	5177	307	"
1976	602	3953	41.47	54.92	4772	274	"
"	603	3966	40.45	55.02	5173	272	"
1978	651	70	59.03	12.53	1558	41	"
"	652	0	59.03	12.55	1551	39	"
"	653	0	59.02	12.57	1551	39	"
1979	675	505	40.37	45.35	4550	393	"
1980	695	214	40.99	152.02	5278	372	"
1981	728	258	41.25	152.01	5356	374	"
"	729		51.00	174.86	4711	419	"
"	730		50.55	174.83	7289	419	"
"	731		49.44	174.80	5608	420	"
"	732	1974	47.91	174.79	5606	419	"
"	734		45.98	174.80	5763	420	"
1983	775	479	41.20	60.04	4027	509	"
"	776	409	40.27	62.04	4886	509	"
"	777	3968	40.22	61.61	4970	509	"
"	779	3979	40.95	60.71	4798	508	"
"	795	129	41.06	174.92	5837	362	yes
"	801	152	41.12	165.04	5317	314	none
1984	820	144	41.06	165.09	5332	21	"
"	821	152	41.09	165.07	5350	384	yes
"	827	118	41.03	175.02	5795	359	none

For purposes of this report, it will be assumed that moored station components located outside 40° north or south latitudes and at depths greater than 2000 meters have been exposed to negligible risk of fishbite and will be considered to have been outside the Fishbite Zone.

Incidence of biting will be calculated upon the basis of number of deployments within the delineated zone (385 stations).

Biting appears to have been a significant hazard as 28% of the mooring lines from within that group were reported to have developed markings characteristic of fishbite. Data for this group of moorings are summarized in Table 3.2.

Table 3.2
Incidence of Fishbite
on
WHOI Moored Stations in the Fishbite Zone

Year Set	Stations Completed	Lines Bitten	
		No.	%
1967	5	2	40
1968	21	0	0
1969	22	6	27
1970	22	7	32
1971	29	8	28
1972	38	6	16
1973	30	5	17
1974	17	7	41
1975	25	2	8
1976	21	2	10
1977	18	5	28
1978	13	8	62
1979	17	10	59
1980	14	9	64
1981	32	1	3
1982	16	5	31
1983	25	10	40
1984	14	10	71
1985	6	3	50
Overall	385	106	28

3.1.3. Yearly variations in fishbite attack.

Fishbite attack appears to have been quite variable from one year to another as is given in Table 3.2 and illustrated in Figure 3.1. For example, in 1968 no lines were reported to have been bitten; next year, at

the same location (Site D, 39°N, 70°W), with a like number of lines exposed, the attack rate was 27%. From 1975 through 1978, the rate of attack at all stations appears to have been on the increase, rising from 8% to 62% of lines placed within the Fishbite Zone. Interesting, if true.

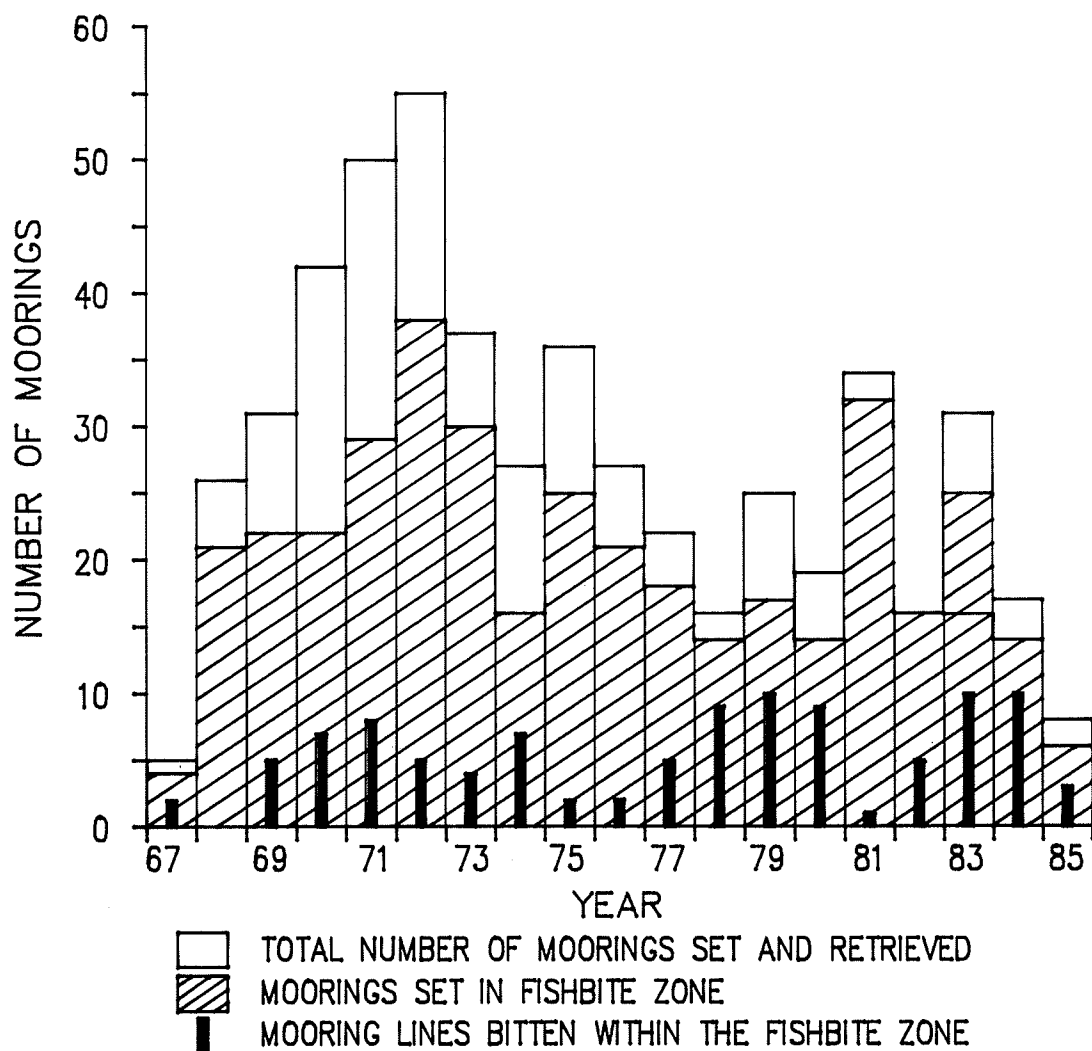

Figure 3.1 Yearly distribution of fishbites from WHOI mooring station logs (1967 - 1985).

Taking the data as they stand in the record, several possibilities appear. One is that fishbite hazard may vary from time to time at the same location, especially if it is near the boundary of the Fishbite Zone. Site D is such a location. In 1968, 21 stations with buoys above 2000 meters depth were completed at Site D, and the record indicates that none of them were bitten. Indeed, 19 of the mooring lines were unprotected synthetic fiber and only one array was lost. The rest were all on station and appeared unbitten after durations of up to 180 days. In 1969, 22 buoys were moored in the same manner at Site D. Six of them, or 27%, had bitten lines when they were recovered. The data suggested that there had been some change at Site D, and in fact it is possible that a meandering of the Gulf Stream put the edge of it over Site D in 1969 and that within the Stream came warm water with sharks, and perhaps other biting organisms.

3.1.4. Fishbite vs. conditions of deployment.

3.1.4.1. Fishbite vs. buoy depth.

In general, there has been a feeling that mooring lines with surface buoys might be more susceptible to fishbite than those whose top floats were submerged. The actual data presented in Table 3.3 and shown graphically in Figure 3.2 do not support such a conclusion. To be sure, a greater incidence of bites (31%) was found with surface buoys than when the line terminated between 1 and 100 meters below the surface (10%) but with increasing buoy depth the percentage of bitten lines increased and did not again reach such a low level until depth of the top buoy was in excess of 500 meters. From 600 meters down to 2000 meters, only 2 bites

were recorded, and incidence of 4%. No bites were found in the 116 mooring lines with a top buoy at 2000 meters or more.

Table 3.3

WHOI Moored Stations 256 through 849
All Stations between 40° N and S Latitude

Buoy Depth Meters	Mooring		
	Total Number Set	Number Bitten	% Bitten
0	112	35	31
1- 99	21	2	10
100- 199	61	31	51
200- 299	19	7	
300- 399	6	1	32
400- 499	71	25	35
500- 599	32	3	9
600- 699	3	1	
700- 799	2	0	
800- 899	2	0	4
900- 999	11	0	
1000-1099	5	0	
1100-1199	0	0	
1200-1299	1	0	
1300-1399	1	0	
1400-1499	9	1	
1500-1599	1	0	4
1600-1699	2	0	
1700-1799	1	0	
1800-1899	0	0	
1900-1999	11	0	
2000+	116	0	0

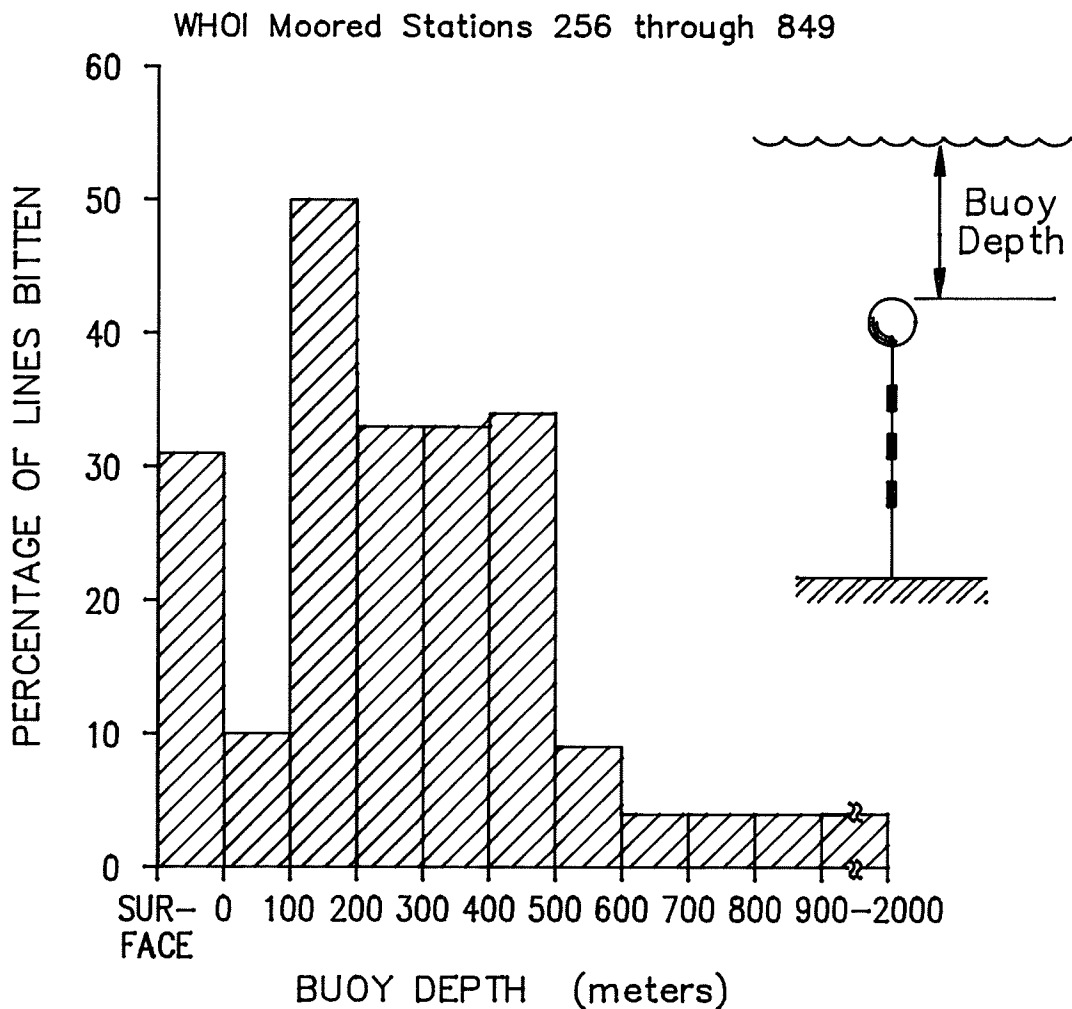

Figure 3.2 Percentage of lines bitten vs. buoy depth.

3.1.4.2. Fishbite vs. geographical location.

One may well ask whether risk of fishbite was found to be uniform throughout the Fishbite Zone as bounded by the 40° parallels. The data indicated that it was not. The risk rose as stations were established closer to the equator. Considering the data in Table 3.4 and shown graphically in Figure 3.3, an inverse relationship between biting and latitude is clearly indicated, but without more data points, it is difficult to establish the details of the relationship. Somewhere

Table 3.4

Fishbite vs. Latitude
WHOI Moored Stations 256 through 654
All lines wholly or partially at 0 to 2000 meters depth

Latitude Degrees	Moorings		
	Total Number Set	Number Bitten	% Bitten
0- 5	19	12	63
6-10	0	0	
11-15	2	0	
16-20	4	0	
21-25	3	0	
26-30	71	27	38
31-35	92	36	39
36-40	198	32	16
41-45	10	2	
46-50	1	0	
51-55	2	0	
56-60	3	0	
61-90	0	0	

within 10 degrees of the equator about 2/3 of all mooring lines were bitten. As latitude increased, the percentage fell off until the risk of biting became very small beyond 40°N latitude.

More data are needed for moored stations at latitudes greater than 40°.

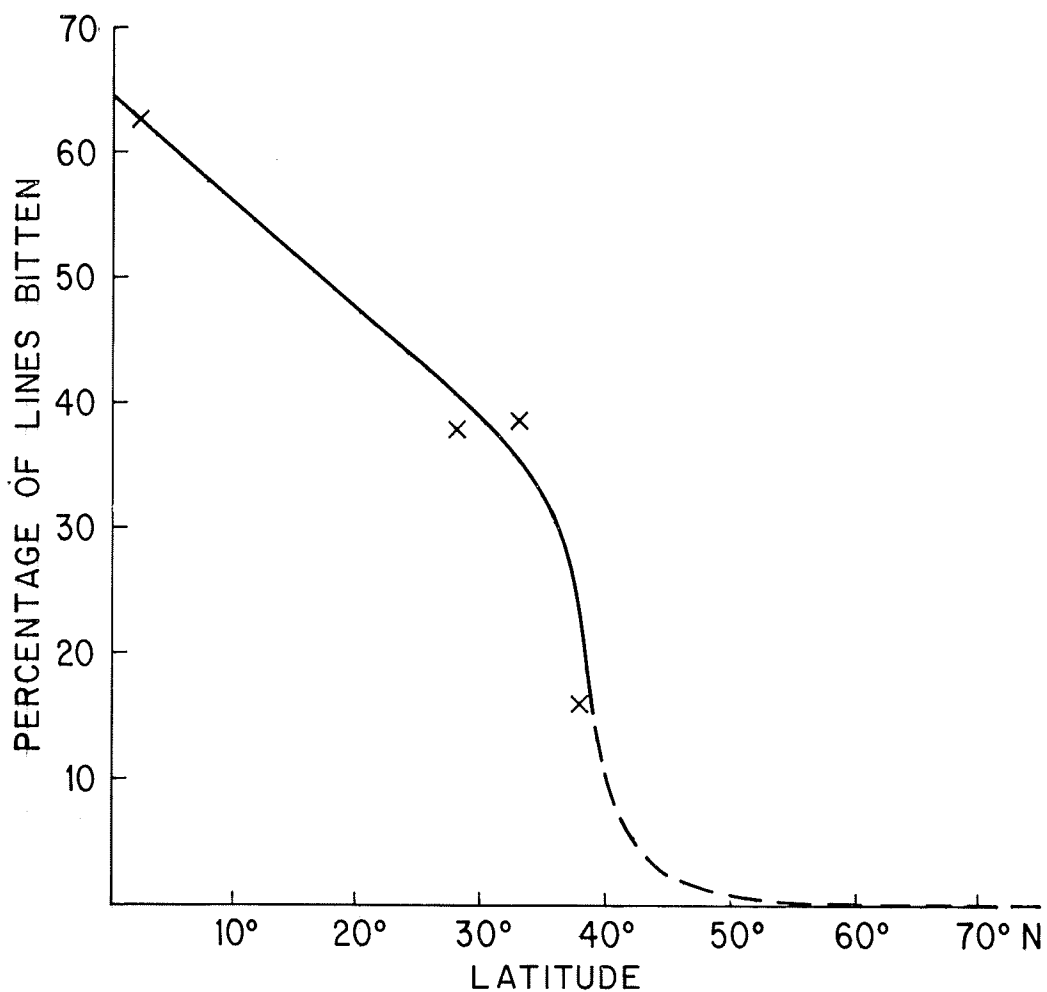

Figure 3.3 Percentage of lines bitten vs. latitude.

3.1.4.3. Fishbite vs. bottom depth.

To date, fishbite has been regarded as mostly a deep water phenomenon. The present data base confirms such a viewpoint (See Table 3.5). No fishbites were recorded at 61 stations in 2000 meters of water or less, though all were within latitudes where fishbite had been encountered in deeper water. Until more evidence becomes available, however, one should probably not write off the possibility that fishbite may occur in shallow water. There is a wide range of conditions in water less than 2000 meters deep.

Table 3.5

Fishbite vs. Bottom Depth
WHOI Moored Stations 256 through 849
All mooring lines within the Fishbite Zone

Bottom Depth Meters	Moorings		
	Total Number	Number Bitten	% Bitten
0- 500	37	0	0
501-1000	11	0	
1001-1500	6	0	
1501-2000	7	0	
2001-2500	4	3	
2501-3000	91	14	15
3001-3500	1	0	
3501-4000	11	5	
4001-4500	16	5	
4501-5000	28	10	36
5001-5500	133	52	39
5501-6000	28	14	50
6001+	13	4	20

3.1.4.4. Fishbite vs. duration of moored station.

One might surmise that the time a mooring line is in the water should have some correlation with the probability that it will be bitten. Does longer duration increase risk of fishbite? Is there a minimum time for bites to occur? Is the rate of biting constant over a period of time?

The record of bites vs. duration is given in Table 3.6 and shown graphically in Figure 3.4, which is a bar graph of mooring duration vs. percentage of lines bitten. Considerable variation is evident from one time interval to another. Overall, an upward trend in percentage of lines bitten seems indicated but fluctuations are so large that any closer analysis is difficult.

Obviously, factors other than time have important impacts on the incidence of fishbites and they should be eliminated by weeding out biased data points.

Table 3.6

Fishbite vs. Duration
WHOI Moored Stations 256 through 849
All mooring lines within the Fishbite Zone

Duration Days	Mooring		
	Total Number Set	Number Bitten	% Bitten
0- 10	42	5	12
11- 50	32	4	13
51-100	48	12	25
101-150	87	10	11
151-200	25	12	48
200-250	31	5	16
251-300	21	6	29
301-350	37	17	46
351-400	40	19	48
401-450	16	11	
451-500		0	
501-550	6	3	
551+	2	1	

Unfortunately, however, the number of moorings placed each year is too small to permit such a weeding out process without seriously weakening the usable data base. Another approach to the problem is to treat the data in such a way that in effect, short duration times are regarded as part of longer duration times. Table 3.7 and Figure 3.5 are presentations of the data from such a viewpoint.

In this approach not all possible environmental conditions are represented but the impact of conditions during any one time interval is lessened and, of course, as time intervals become larger and more

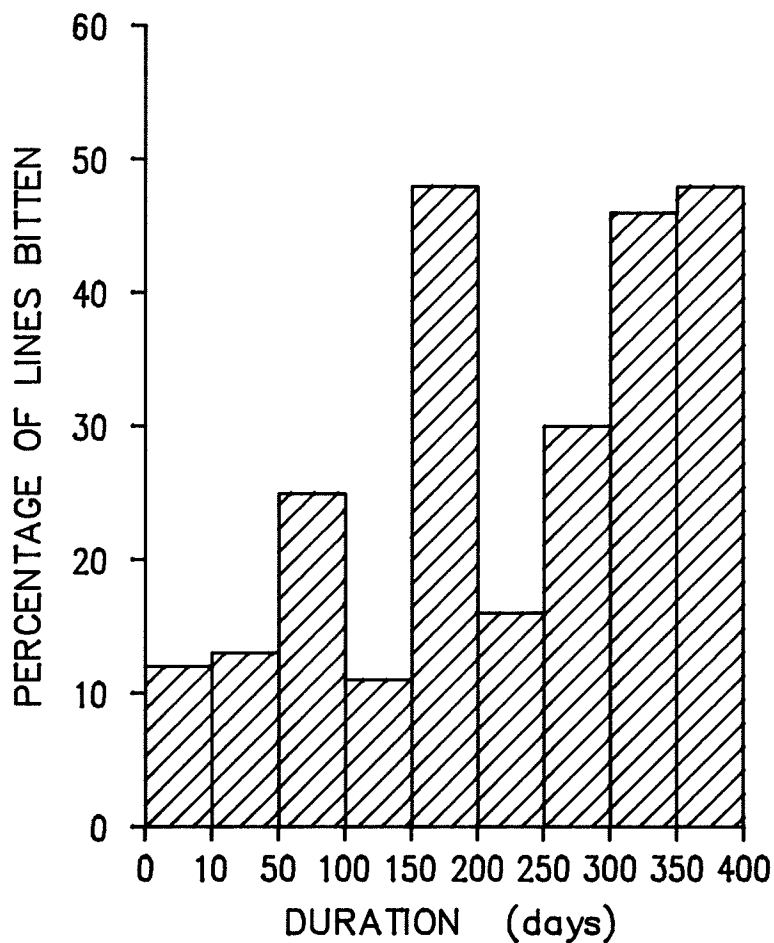

Figure 3.4 Percentage of lines bitten vs. duration.

moorings are deployed a limit is reached where all environmental factors are considered. Time then becomes the dominant variable.

The lack of continuity in earlier time intervals in Figure 3.4 shows the influence of variables other than time. In contrast, the steady increase in percentage of bites with time in later intervals

Table 3.7

Fishbite vs. Cumulative Duration
 WHOI Moored Stations 256 through 849
 All mooring lines within the Fishbite Zone

Duration up to - days	Mooring		
	Total Number	Number Bitten	% Bitten
-10	42	5	12
-50	74	9	12
-100	122	21	17
-150	209	31	15
-200	234	43	18
-250	265	48	18
-300	285	54	19
-350	322	71	22
-400	362	90	25
-450	378	101	27
-500	379	101	27
-550	385	104	27

indicates that time has become preponderant. Using the method of least squares to fit a straight line to the data points so derived, a biting rate of about 3%/100 days (correlation coefficient = 0.95) is indicated. The regression line begins at zero time at a level of 11.5% line bitten which indicate that some lines may be attacked during launch. Such attacks have been observed (O'Malley, 1976) on rare occasions. On the other hand, the data base showed a definite trend of increased risk as the exposure time increased. It is reasonable to expect that on an average one mooring out of four would be attacked if set within the Fishbite Zone for a period of up to 450 days.

3.1.4.5. Fishbite vs. depth of occurrence at a single location.

Several detailed studies of the relation between fishbite and depth

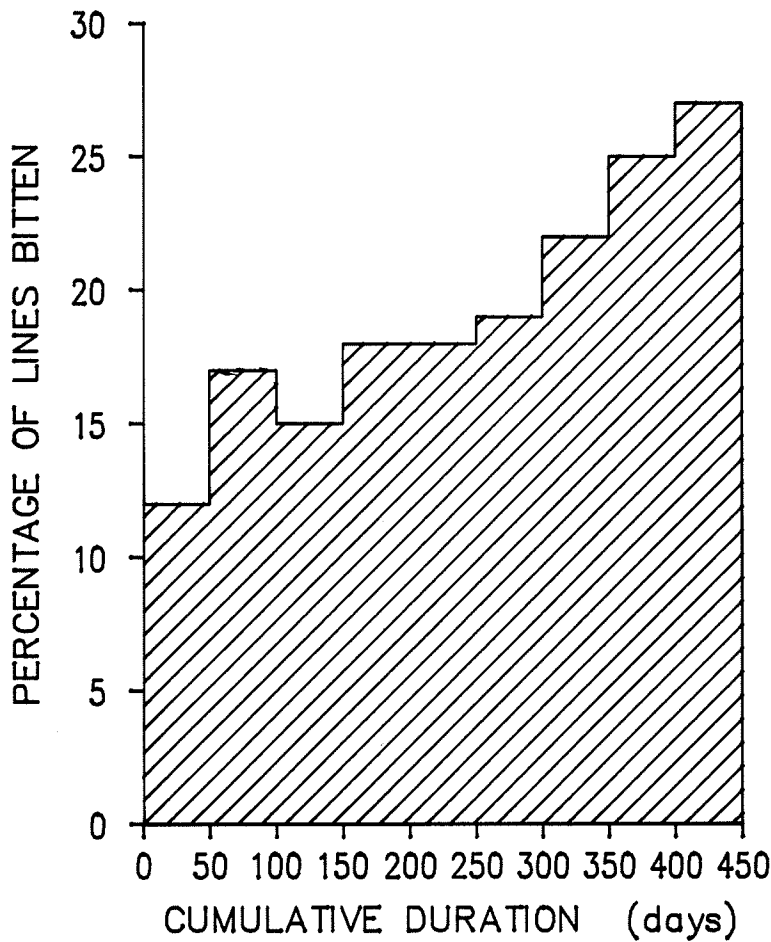

Figure 3.5 Percentage of lines bitten vs. cumulative duration.

at a single location were made in the past.

One (Turner and Prindle, 1968) was conducted on a mooring line which had been placed at $32^{\circ}23N$ and $64^{\circ}22W$ off the coast of Bermuda. It was in the water for a period of 82 days.

The mooring line was a 1 x 19 galvanized steel wire rope, 3.78 mm in diameter, coated with HD polyethylene to an outside diameter of 8.13 mm. The coating took excellent dental impressions and retained a few fragments of teeth. The recovered line was run through a metering device and records were made of the depths at which evidence of biting were found.

Frequency of bites as a function of depth is plotted in Figure 3.6. The mean thermal structure of the water in that locality is also shown (Fuglister, 1960). The major fraction of the bites occurred between 600 and 1000 meters in depth with the peak of activity between 900 and 1000 meters. This indicated that the population of biters was concentrated near the bottom of the permanent thermocline with a few stray individuals in the upper and lower waters.

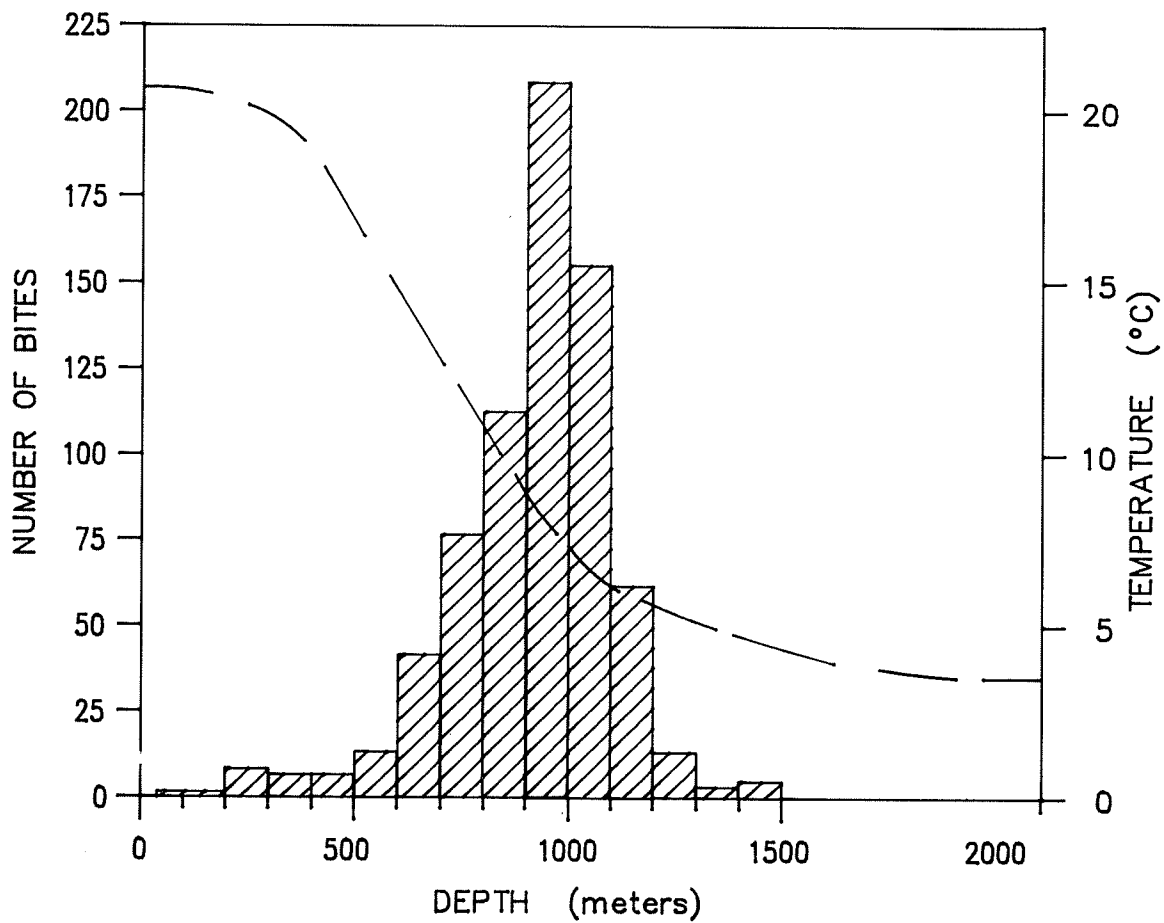

Figure 3.6 Frequency of bites as a function of depth (Prindle and Walden, 1975).

Most of the bites which occurred in the waters off Bermuda were a minor type and did not penetrate the polyethylene covering on the line. However, a few of them did puncture the coating and exposed the underlying wire to the action of sea water. It seemed evident that an unprotected synthetic fiber line would have suffered severe, if not catastrophic, damage under the same circumstances.

A similar pattern of bites was reported by LeGall (1972) at a site 40 nautical miles (74 km) south of Cap St. Vincent ($36^{\circ}30'N$, $09^{\circ}00'W$). He found tooth marks on nylon cables at depths of 700 to 1000 meters.

A second pattern of fishbite attack with a concentration of relatively severe bites near the surface has been observed (Stimson and Prindle, 1972). Typical examples are represented by the results obtained from the WHOI moored stations, #298 and #300 which were set at $39^{\circ}N$, $70^{\circ}W$ (WHOI Site D). The top 1500 meters of each line was steel wire rope covered with high density polyethylene. The duration of the stations and numbers of bites observed on the retrieved lines are shown graphically in Figures 3.7 and 3.8.

The total number of cuts in the moorings was 115, much less than in the previous (Bermuda) case. In terms of bites per day of exposure, a less concerted attack was noted. In addition, most of the bites were closer to the surface. A different species of biter seems indicated. A number of the bites were severe. Four gashes in the line on moored station #298 bared the wire; and in the case of moored station #300, one bite pierced the jacket.

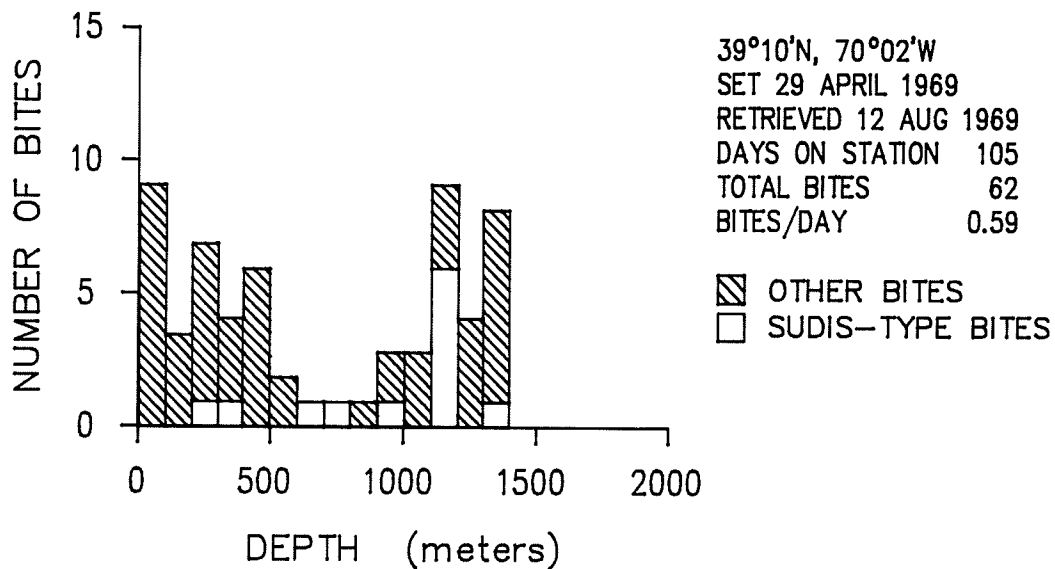

Figure 3.7 Number of bites vs. depth (Station #298).

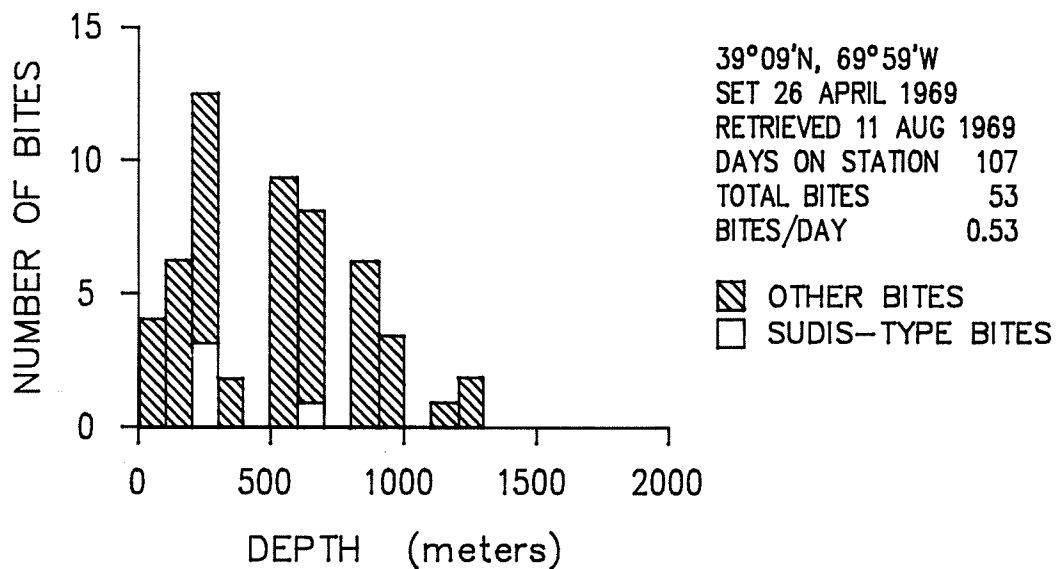

Figure 3.8 Number of bites vs. depth (Station #300).

3.1.4.6. Fishbite vs. depth of occurrence world wide.

The fishbite data in the station logs indicated a depth range within which the bites had occurred, The ranges were not consistent, varying from a few meters resolution to bites observed somewhere on a 1000 meter long cable. Within these ranges, the center point of each bite recorded was calculated and plotted by 100 meter intervals. The resulting histogram (Figure 3.9) provides statistical information, supplemented by the buoy depth data, which can be used for a risk analysis.

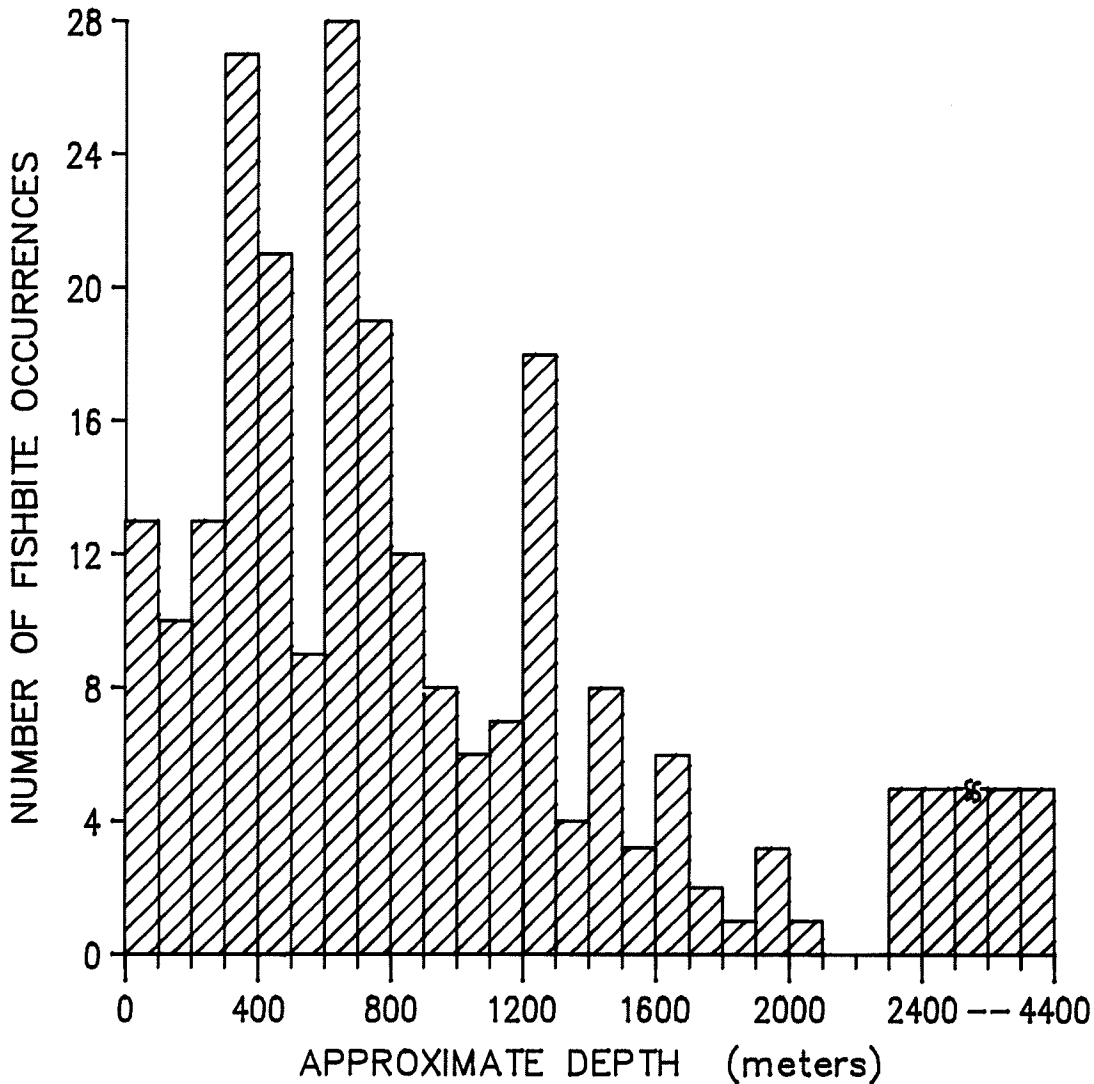

Figure 3.9 Number of fishbites vs. depth (Worldwide).

91% of the bites occurred at depths shallower than 1500 meters and 97% at depths shallower than 2000 meters (Table 3.8). Moreover, it may well be that the few bites recorded as great depth bites in fact occurred during launch or recovery. The great majority of fishbite incidence was between the surface and 1000 meters depth. The fishbite versus buoy depth data confirm these findings as no bites were observed on moorings with buoy depths greater than 2000 meters, and only 4% of the moorings deployed with buoy depth between 600 and 2000 meters were bitten.

Table 3.8
Fishbite vs. Depth of Occurrence
WHOI Moored Stations #246 through #849

Approximate Depth of Occurrence (Meters)	Number of Bites
0- 100	13
101- 200	10
201- 300	13
301- 400	27
401- 500	21
501- 600	9
601- 700	28
701- 800	19
801- 900	12
901-1000	8
1001-1100	6
1101-1200	7
1201-1300	18
1301-1400	4
1401-1500	8
1501-1600	3
1601-1700	6
1701-1800	2
1801-1900	1
1901-2000	3
2001-2100	1
2101-2200	0
2201-2300	0
2301-4400	5

3.1.5. Conclusions.

Analysis of the data from 550 WHOI moored stations, established in the years 1967 through 1985, leads to the following conclusions:

- . 99.3% of fishbites occurred within an ocean space designated as the Fishbite Zone which was bounded by 40° North and South parallels and depth levels of 0 and 2000 meters.
- . Fishbite is a significant hazard to deep sea mooring lines. It was reported to occur on 27% of all lines set within the Fishbite Zone.
- . Risk of fishbite was found to be inversely correlated with latitude from zero at approximately 42° North to 63% of the lines set within 5 degrees from the equator.
- . Within the Fishbite Zone, moorings with buoys between the surface and 500 meters depths are most susceptible to fishbite attacks. Below 500 meters fishbite hazard falls off and is zero at 2000 meters depth and deeper.
- . The data base shows a definite trend of increase of risk as exposure time increases. It is reasonable to expect that on an average, one mooring out of four will be attacked if set within the Fishbite Zone for a period of up to 450 days.

3.2. World wide distribution of fishbites.

In addition to the Woods Hole Oceanographic Institution other sources have reported fish attacks on mooring lines. A synopsis of these reports is shown in Table 3.9.

Table 3.9

Data for World Fishbite Chart
Non-WHOI Data

Site		Locality	Reference	
Lat.	Long.			
25°N	80°W	100 mi. E. Miami, FL	Banchero, L.B., 1966	
32°00'N	64°40'W		Brown, C.L., 1966	
43°N	57°W		Castelliz, H., 1974	
		Off St. Croix, V.I.	Collier, 1972	
17°54'N	64°45'W		General Electric Co., 1976	
17°50'N	64°45'W		General Electric Co., 1976	
32°00'N	64°40'W	Off Bermuda	Giuliano, D.F., 1968	
33°N	118°W		Hartman, P.L., 1972	
36°30'N	09°00'W		LeGall, J.Y., 1972	
36°31'N	09°01'W		Madelain, D.F., 1971	
17°52'N	64°42'W		Mosey, R.M., 1975	
39°01'N	73°36'W		O'Brien, T.F., 1981	
25°54'N	89°42'W		Prindle, B., 1980	
29°18'N	77°18'W		Prindle, B., 1983	
34°N	70°W		Prindle, B., 1983	
23°52'N	77°25'W		Prindle, B., 1985	
29°59'N	165°01'W		Sessions, M., et al., 1969	
43°00'N	164°00'W		Sessions, M., et al., 1969	
28°30'N	57°5.6'W		Skipp, P., 1975	
28°N	78°W		North of Bahamas SE of South Pacific	US Oceanogr. Office, 1965 Zahn, G.A., 1974

When the information from all sources is plotted on a world chart, the geographic distribution of fishbite incidence is as shown in Figure 3.10. The chart also shows solid and dashed lines north and south of the equator. The dashed lines indicate the highest latitude of shark activity during the summer seasons. The solid lines bound areas where sharks are active year round (Cousteau, 1970).

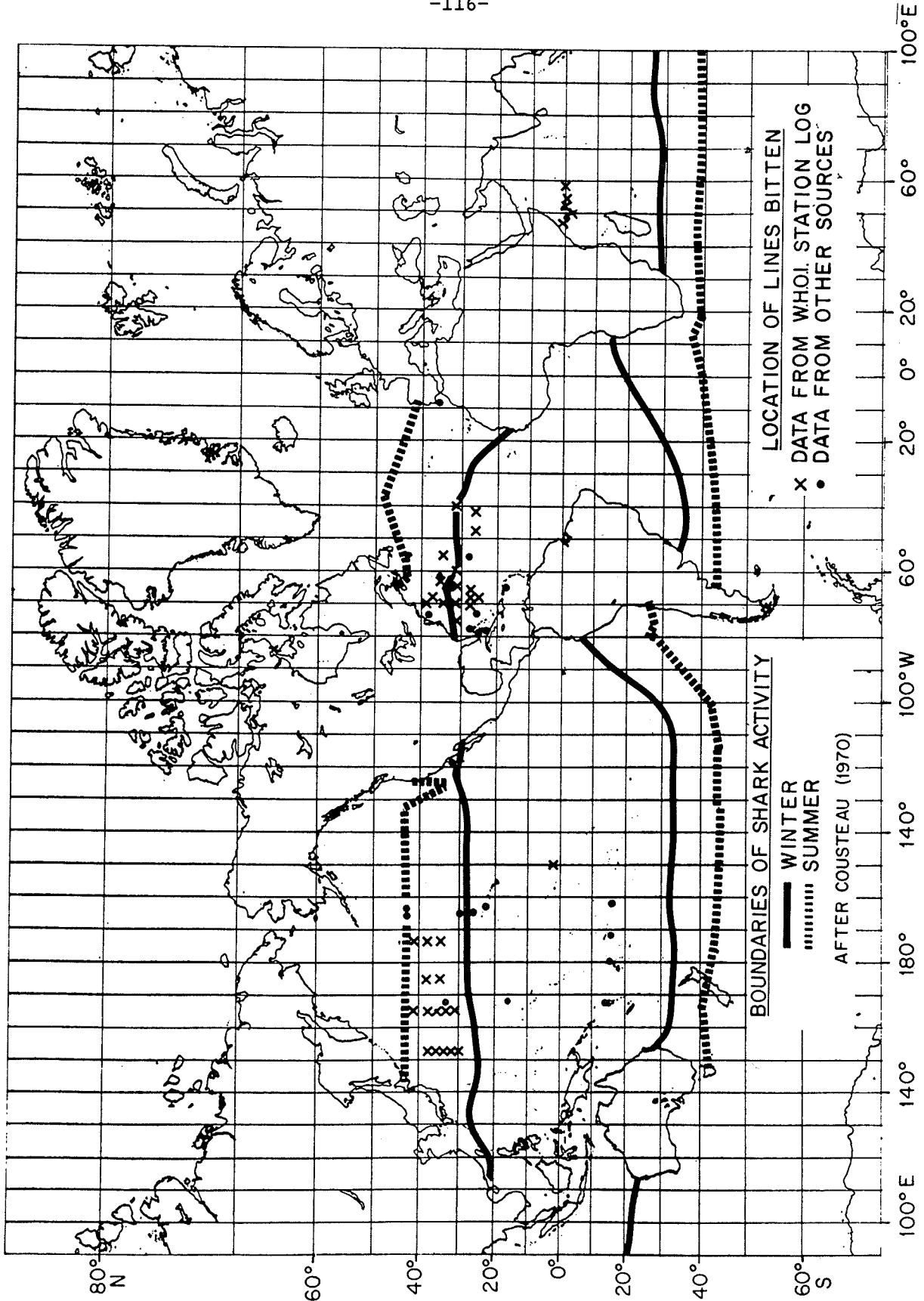

Figure 3.10 World geographic distribution of fishbite incidence.

This chart seems to indicate that a correlation exists between fishbite and warm surface water. In fact, no bites have been reported outside the shark activity boundaries shown, and only a few incidents occurred outside of the 40° latitude.

However, it must be noted that the present data base is strongly biased. Less than 4% of all the moorings included in this study were set at latitudes greater than 40° and there is practically no information from the Southern Hemisphere. More data are needed before all parts of the world oceans are properly represented.

The incidence of water temperature on fishbites is further discussed in Chapter 4.

CHAPTER 4 - BITING ORGANISMS AND PREDISPOSING FACTORS

4.1. The pelagic environment.

Let us brush in large strokes a succinct picture of the environment in which deep sea moorings must survive. As many sailors would attest, perhaps the characteristic which most aptly describes the vast extents of the open sea is emptiness. Presence of life, to the untrained eye, seems to limit itself to dolphins and whales, spotted as they come to breathe and play at the surface of the sea. Yet those sailors, fishermen and oceanographers which plough the seas at a slower pace and make frequent stops by day or night can enumerate and describe a large variety of open sea living organisms. Their concentration or abundance however seem to vary greatly from time to time and place to place.

For most of human history, little was known about the inhabitants of the deep, often depicted by wild and frightening images. Intensive research and exploration conducted in the last hundred years, with man finally reaching and observing the deepest ocean trenches, has tremendously increased our knowledge of the deep and its creatures. There again, from the warm and well lit boundary of the surface to the impenetrable blackness of the deep, life appears to be spotted and somewhat stratified with large layers of almost total emptiness.

These areas of life concentration, both at the surface and in the water column have obviously the most impact on mooring survival.

The great expanses of open oceanic waters constitute the pelagic realm or pelagic environment. This volume which accounts for most of the earth's water, is often divided for practical and didactic reasons in four zones: the epipelagic, the mesopelagic, the bathypelagic and, at the

bottom, the benthopelagic zone. Figure 4.1 shows the approximate depth limits of these zones.

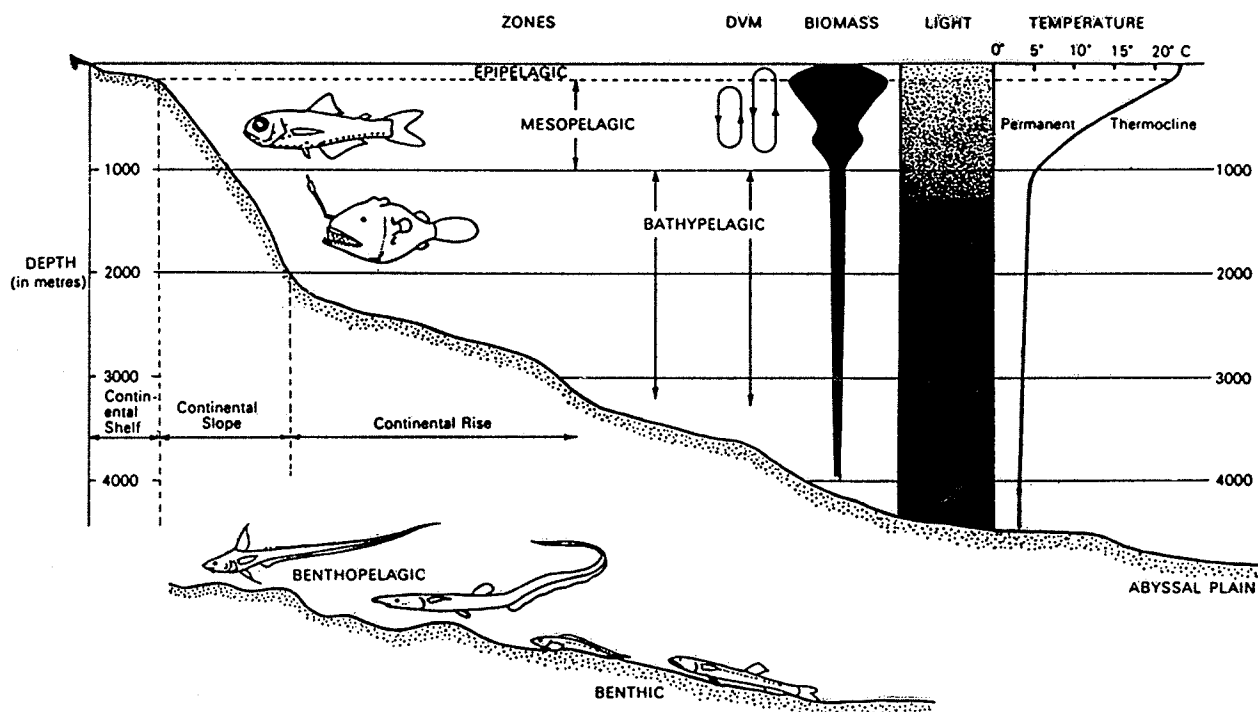

Figure 4.1 The pelagic environment.

(From: Exploration in the life of fishes, N.B. Marshall, 1971)

The epipelagic (or euphotic) zone is the thin, well mixed, upper layer of the ocean, often characterized by constant temperature. Its depth varies with seasons and locations from some 25 meters in the high latitudes to 200 meters and more in tropical waters where the average temperature of the layer reaches 20°C.

The epipelagic zone is the cradle of open sea life. It is within its well lit and warm layer that the multitude of small plant cells which constitute the phytoplankton grow and thrive. When bountiful, this supply is grazed by herbivorous small planktonic or drifting animals, including some small fish. The zooplankton in turn is prey to carnivorous

creatures, small and large, which also have their predators. The epipelagic is most productive when waters rich in mineral and organic nutrients are brought in by surface or upwelling currents. Great abundances of fish can be found in these areas. Much of the open ocean however remains a "wet desert."

About 70 families of fish are represented in the epipelagic (Bond, 1979). They range in sizes from the smaller gregarious fish such as anchovies, mackerels, and sardines, which conglomerate in large schools to the solitary, 18 meter, giant whale shark. The predominant fast swimmers such as tunas, marlins, swordfish, and pelagic sharks, often follow these schools or cross the far reaches of the sea in search of new prey. Drifting seaweeds, floating debris, and of course buoys attract small animals seeking food and shelter. Larger fish, blue dolphins for example, soon will lurk under these shelters, feeding on the smaller organisms.

Many epipelagic fish are capable of inflicting severe damage to mooring lines. Among them the most formidable and dangerous remain the pelagic sharks, particularly those of the Lamnidae and Carcharhinidae families.

Below the mixed layer comes a zone of rapidly falling temperature, the permanent thermocline. Rate of temperature drop can be as much as 1°C per 10 meters. Below this thermocline the temperature of the sea remains practically constant, a cold 2°C on an average. The mesopelagic zone is considered to extend down to 1000 meters, well below the thermocline in most places, and down to the very limit of light penetration.

Debris raining down from the active epipelagic form the food base for a sometimes abundant zooplankton community which includes species with the

habit of migrating to the surface or shallower waters during the night. An explanation for the strange behavior of these strong swimmers which must travel several hundreds of meters twice a day has been proposed by Isaacs (1969) who writes "This behavior is probably a tactic to enjoy the best of two worlds: To crop the richer food developing in the surface layers and to minimize mortality from predation by remaining always in the dark ..." These vertical migrations are followed by many mesopelagic fishes. Some can be found in the isothermic warm waters of the epipelagic. Others, probably constrained by temperature tolerances, barely penetrate the bottom of the thermocline where they remain in numbers large enough to create a "deep sea scattering layer" which scatters back the sound waves coming from the surface thus making submarine chasing that much more interesting.

There is a great diversity of life in the twilight mesopelagic zone. More than 1000 species of fish are represented, some of them interzonal. Predatory fish, with names as descriptive as California smooth tongue, Barreleye, Hatchetfish, Viperfish, Lancetfish, Lanternfish, and Swallower are abundant. Their sizes can reach one meter or more. They usually have large eyes, large mouths and formidable teeth. The swallower has a distensible stomach and routinely swallows preys larger than he is.

Excluding attacks occurring at or near the surface, the majority of fishbites on deep sea mooring lines can be traced back to mesopelagic fish. As evidenced by the histograms shown in Figures 3.6 and 3.9 their depth of maximum activity seems to range within the bottom layers of the permanent thermocline, from 600 to 1000 meters.

The bathypelagic zone starts when all light disappears. The circle of dark charcoal which outlined the ALVIN's top porthole is now

indiscernible. The environment is uniformly and totally black, remote, and cold. Yet in these Dantesque surroundings, flashes of light here and there attest to some form of life hard to comprehend. Well adapted creatures, fish and squids, still exist in these depths, sharing or rather competing for the meager food resources still falling from the top layers. Bioluminescence is omnipresent with two thirds of the species emitting some form of light for recognition, luring, or evasive purposes. As a group these Lilliputian monsters despite their capacious mouth and their impressive teeth do not constitute a demonstrated danger to mooring lines.

The benthopelagic and the benthic zones contain these species living near or on the bottom. Near the continental slopes cold water fish can be found to bottom depths of 1000 meters. Moving towards the abyssal plains however, larger bottom dwellers seem to disappear. Food particulates no longer falling through the water column concentrate on the deep bottom. This food supply supports a loose array of scavengers, filter feeding organisms including sponges, worms and bivalves, and some smaller fish such as the tripod fish.

Large grenadiers and even sharks have however, been photographed near the deep sea floor (Isaacs, 1969; Clark, 1986). These fish apparently survive on the occasional fall of large food fragments that are in excess of the local feeding capacity of the meso- and bathypelagic zones. Such falls would include dead sharks and whales or large remnants from predators attacking schools of surface fish and even garbage from passing ships. This activity being mostly localized at or near the floor, it remains prudent to well protect the lower end of deep sea moorings. Lengths of chain placed above the anchor may have so far accounted for the lack of recorded fishbites near the bottom.

4.2. Moorings as centers of biological activity.

It has been known for a long time that marine life becomes centered around lines moored at sea. A considerable variety of organisms may be found. Some are sedentary, such as barnacles, bryozoa, and algae fastened to items in the array. Others are pelagic and include squid, small and large fish and visiting porpoises. The aggregations of fish have attracted at least two varieties of fishermen. Off duty oceanographers have found sport fishing for "dolphin," Coryphaena hippurus to be both relaxing and a pleasant way to enhance the dinner menu. A more serious long term application of the fish aggregation properties of deep sea mooring lines has been developed in the South Pacific (Boy and Smith, 1984) where moored arrays have been found highly effective as Fish Aggregation Devices (FAD) in the tuna fishery. There, the use of FADs has resulted in larger catches, reduced fuel consumption, shorter time to market and improved safety. However, the immediate point of interest here is obviously not better fishing but rather the observation that moored arrays, especially those in warm waters, become centers of biological activity and encourage the proliferation of biters.

Like other problems, control of the fishbite problem depends ultimately upon understanding the cause. In the present case, there are two aspects to be considered:

1. Identification of marine organisms which have significant biting capabilities.
2. Environmental factors and processes which lead to fishbite damage.

4.3. Marine organisms with significant biting capabilities.

Considering possible biters in order of their phylogeny, the first candidates are found among the Mollusca.

4.3.1. Mollusca.

Snails and squid have received attention as possible causes of damage on deep sea lines. One unconfirmed report, based upon examination of an embedded tooth fragment (Sagstad, 1983) implicated a "rasp-toothed snail" as the cause of cuts in the plastic jacket of a thermistor chain.

Squid and perhaps octopus would seem to have biting capabilities worthy of consideration. The former are often found in large numbers when an oceanographic ship visits a buoy site. Can they and do they bite lines? There are few records which indicate that squid have been closely associated with mooring lines. Marra (1974) found squid parts including beaks inside the stranding of synthetic fiber ropes. Turner (1969) reports a squid bite on a cable placed in the Arabian Sea. The damaged area contained a notch of the sort produced by a squid beak.

The biting instrument of a squid is a chitinous beak, and although its edges are quite sharp, the material is not very hard. Although squid can cut notches in flesh and might make marks on a soft polyethylene, it seems doubtful that they could produce the clean cuts that one sees in synthetic fiber mooring lines made of nylon or polyester. Stimson (1964) has estimated that to have a beak large enough to encompass a 12.7 mm diameter line, a squid would have to have a size of 1.5 meters.

Fish, on the other hand, have been repeatedly implicated in attacks upon mooring lines and instruments.

4.3.2. Chondrichthyans (Cartilage fish).

In 1965, a magnetometer case made of polyvinyl chloride and about 15.24 cm in diameter was found upon recovery to have 30 shark teeth embedded in it (Willis, 1985). The instrument had been towed in the Indian Ocean at 09°06'S and 51°55'E at 8 to 10 knots and at a depth of 50 plus meters. The attacking shark was identified (Backus, 1984) as genus Carcharhinus, species probably falsiformis (silky shark).

The next year, sharks were again identified as a cause of fishbite in a mooring array when Schick and Marshall (1966) found the teeth of a mako shark (Isurus oxyrinchus) embedded in the wall of a polyethylene pipe used as armor on the line of a buoy moored in the Pacific Ocean at 30°N and 140°W. Banhero (1966) described a biting incident in which 30.5 meters of 25.4 mm diameter plastic covered cable was damaged at a depth of 365.8 meters in the Atlantic Ocean 644 kilometers due east of Miami. Eight temperature sensors were severely damaged, and the attacking shark left pieces of teeth, which though adequate for identification of the biter as a shark were not enough for species identification.

Two sharks of the Carcharhinid family, the white tip shark (Carcharhinus longimanus) and the great blue shark (Prionace glauca) have been most frequently encountered at buoy sites in the North Atlantic where fishbite has occurred. A record of 170 captures of sharks (Prindle and Walden, 1975) shows clearly that the ranges of oceanic white tip sharks and the blue sharks overlap, and indicates that white tip sharks are the more abundant in the open ocean within a zone bounded roughly by the 30° parallels north and south. Outside of that area, the blue sharks appear to be more prevalent than the white tips. Teeth of the white tip sharks

have not been recovered from bitten lines although they are admirably well constructed for cutting the same. Figures 4.2 and 4.3 are pictures of the jaws and teeth of two carcharhinus sharks.

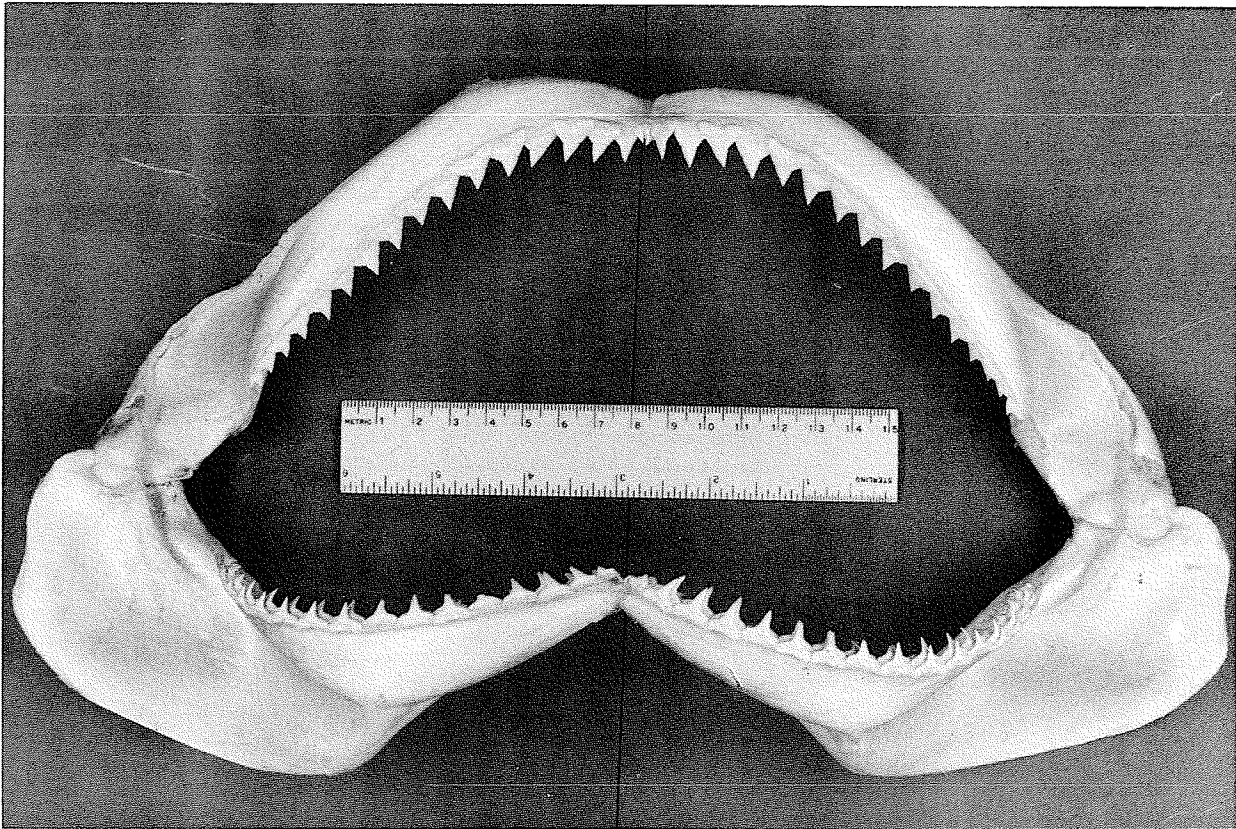

Figure 4.2 Jaw of *Carcharhinus falciformis* (silky shark).

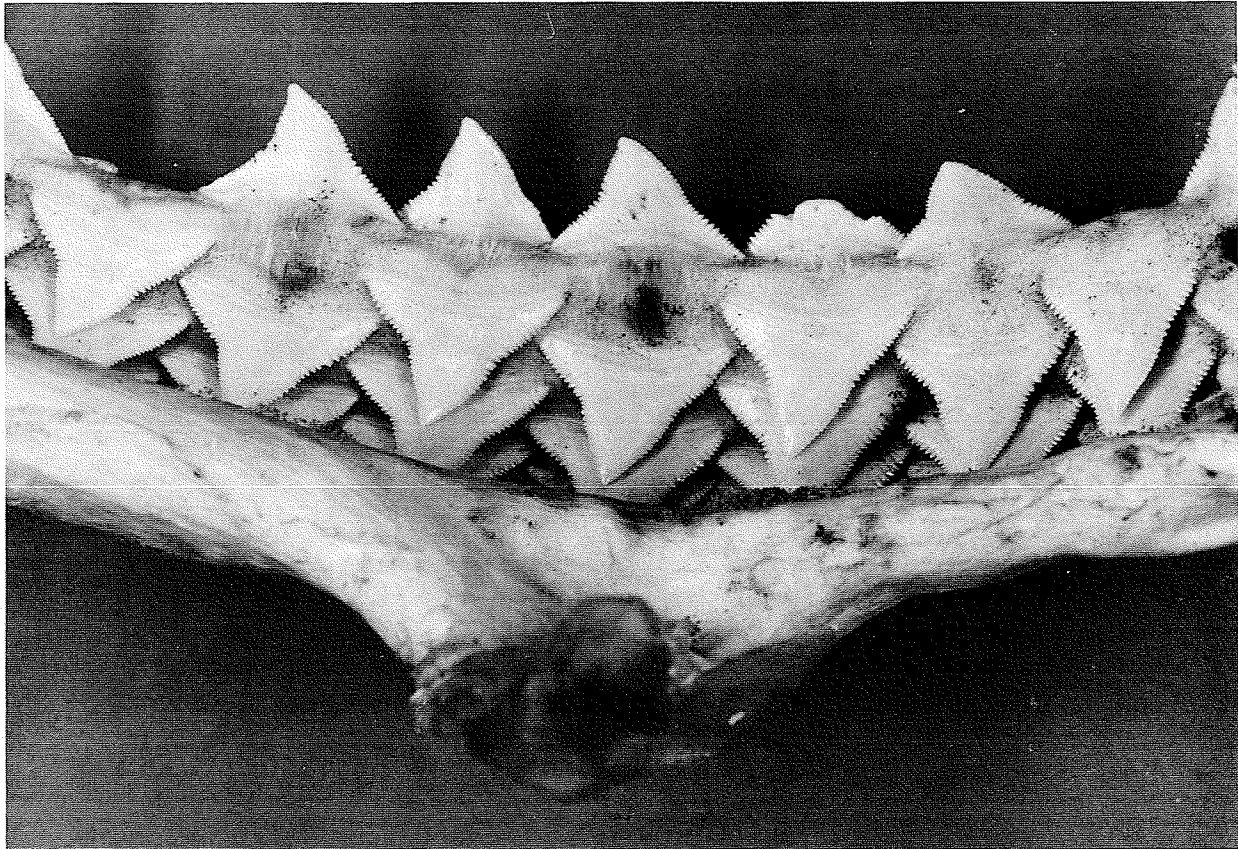

Figure 4.3 Teeth of Carcharhinus longimanus (white tip shark).

4.3.3. Osteichthyans (Bony fish).

At least three species of bony fish have been implicated in damage to deep sea moorings.

The first bony fish to be identified as a mooring line biter came to light as a result of an experimental mooring placed off the shore of Bermuda (Turner and Prindle, 1968) for the purpose of detecting activity.

Upon recovery, the mooring line was run through a metering device and closely examined for evidence of biting.

It was found that the polyethylene retained over 1000 cuts and impressions which could be attributed to biting. They were arranged in informative patterns. Most of the "bites" occurred in pairs indicating jaw widths of 25 to 60 mm. The line was cut on one side only indicating that the biter had well developed teeth on only one jaw. Recovery of tooth fragments proved that biting had in fact taken place. Most of the cuts did not penetrate the 1.8 mm polyethylene jacket, but four of them did. If the wire had been used as an electrical conductor, failure would certainly have resulted.

Frequency of bites plotted against depth has been previously shown in Figure 3.6. The major part of the bites occurred between 600 and 1000 meters depth with peak activity between 900 and 1000 meters. The latter was near the bottom of the thermocline as measured by Fuglister (1960) and shown also in Figure 3.6.

From the above evidence and a study of tooth fragments, Haedrich (1965) identified the biter as a bony fish, Sudis hyalina, Figure 4.4. It is a fish with strongly developed teeth in the lower jaw only. The teeth of S. hyalina are efficient stabbing tools. They have a crystalline structure which is found by means of an alizarine test to be calcareous. They have serrated edges and are very sharp (Figure 4.5).

A second bony fish which produces bites at considerable depth was found off the west coast of Spain, as described by LeGall (1972). In this case, damage occurred in two nylon mooring lines at 36°30'N, 09°00'W and at 37°00'N, 09°30'W off Cap Vincent at depths of 700 to 1000 meters.



Figure 4.4 Sudis hyalina (405 mm length).

Positive identification of the biter was again established from tooth fragments and habitat. It proved to be "sabre" or "espada", a well known food fish, scientific name Aphanopus carbo. It is captured commercially by long lining at depths of 550 to 1000 meters off the coast of Madeira. Experimental fishing off the west coast of Brittany resulted in 15 captures, 11 between depths of 1000 and 1100 meters. Off the coast of Scotland, the same fish is caught at depths of 250 to 740 meters. It has also been captured over the continental shelf off Newfoundland. LeGall suggests that the environmental factor which controls the distribution of A. carbo may well be temperature, and that is why it is found at greater depths where surface water is warm.

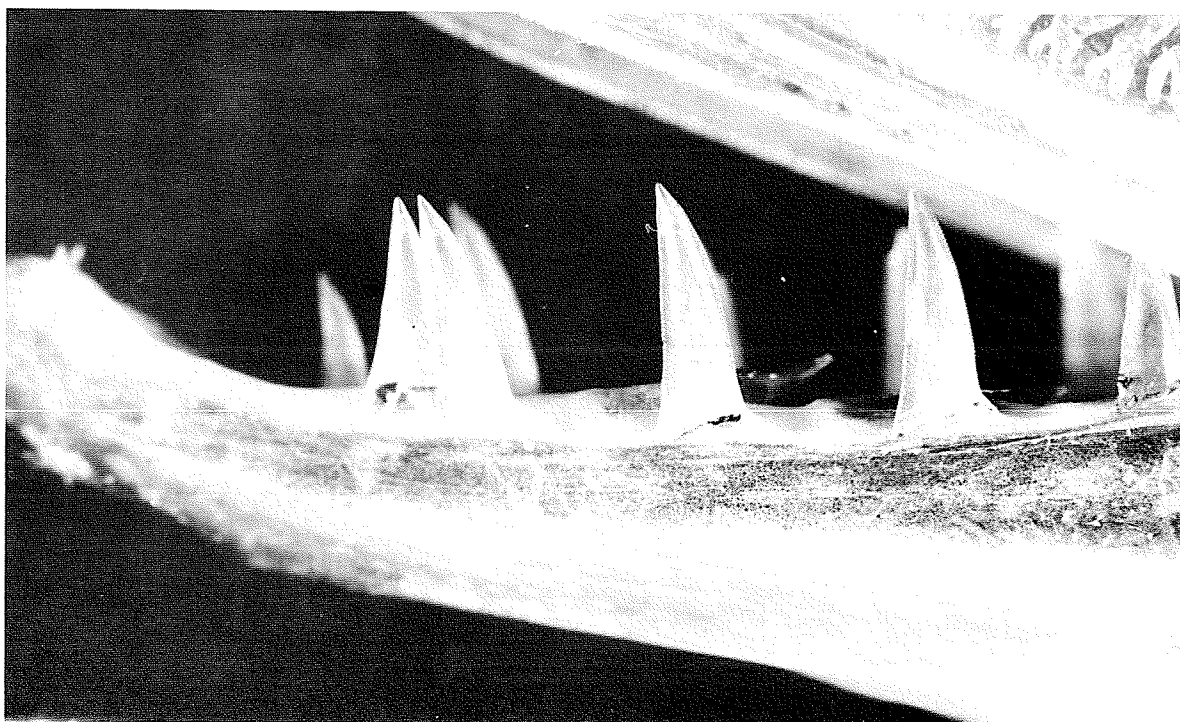

Figure 4.5 Lower jaw of Sudis hyalina.

Aphanopus carbo has teeth in both jaws as shown in Figure 4.6. They are smooth edged, slender, and pointed (Figure 4.7).

Bony fish have been involved in two other attacks on moored arrays, although not on lines per se. One was an attack on pine panels (Turner and Prindle, 1965). Five tooth points were found imbedded in a pine panel which had been moored at a depth of 150 meters off the coast of Bermuda.

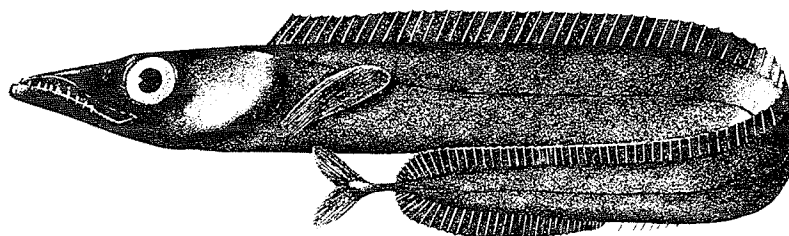

Figure 4.6 Aphanopus carbo (LeGall, 1972).

They were identified as teeth from a lancet fish, Alepisaurus ferox (Figure 4.8 and 4.9). The latter are slim, pointed, very sharp, and are well developed in both upper and lower jaws.

A. ferox was positively identified as a deep sea line biter when a tooth was found embedded in a thermistor cable at a depth of 270 meters. Numerous other clean cuts were found in the Dacron mooring line and in the waterproof covering of several thermistor leads. The thermistors were

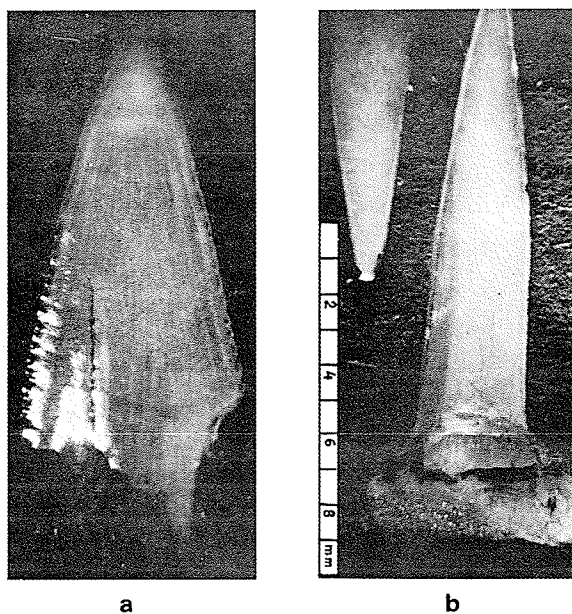

Figure 4.7 Teeth of Aphanopus carbo (LeGall, 1972).

disabled and the buoy went adrift in heavy seas and winds caused by a hurricane. Original site of the mooring was off Bermuda at $32^{\circ}00'N$ and $64^{\circ}40'W$ (Giuliano, 1968).

A second incident involved a swordfish which attacked a current meter and became trapped. In neither of these last two incidents was a line bitten, but stimulation of interest and attack on moored items was apparent.

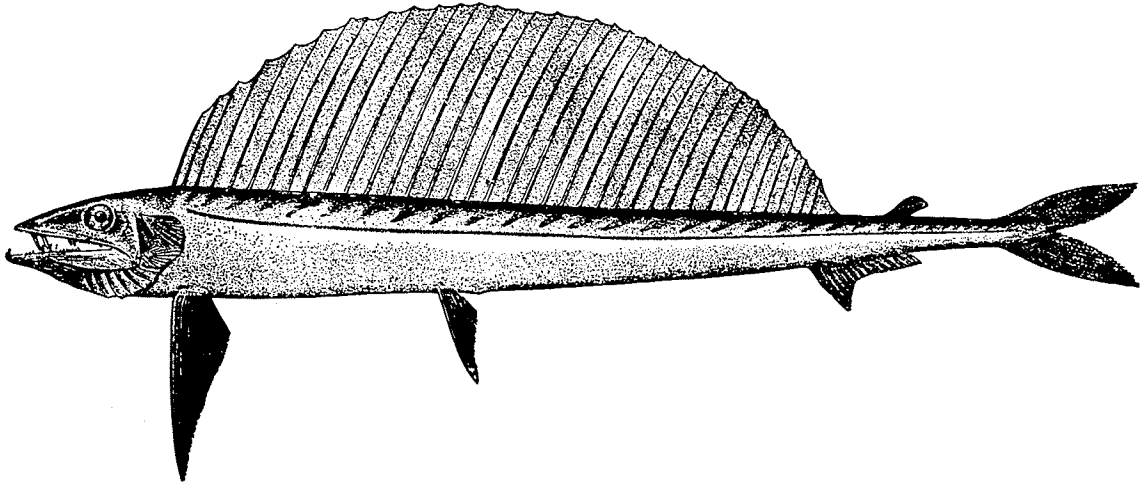

Figure 4.8 *Alepisaurus ferox* (lancet fish).



Figure 4.9 Skull of *Alepisaurus ferox*.

4.3.4. Sea turtles.

Sea turtles have been known to attack man made items. The leatherback (Dermochelys coriacea (Linne)), is completely marine and rarely seen in shallow water. It is a warm water species and its range corresponds well with areas of high fishbite activity. It has a record of attacking boats and oars (Ditmars, 1933 and Pope, 1939). The loggerhead turtle (Caretta caretta (Linne)) has a wider range which includes the fishbite zone. It can crunch conch shells with its beak and is reputed to be active and vicious (Carr, 1952). Its food is mainly conch and other shellfish but it also eats Portuguese Man O'War. Far at sea with no shellfish available, it may be possible that a buoy with its pendant line carrying some hydroids and entrapped siphonophores would look inviting to a loggerhead turtle.

In tests made for the Structures Division of NOL's Underwater Mechanical Engineering Department, fiberglass mine cables and electrical cables placed in a tank with captive sea turtles were bitten unless they were buried (Anonymous, 1968).

Turtle beaks are not the type of razor sharp cutting instrument which is indicated as the prevalent cause of fishbite damage to mooring lines. They are of a horny material whose edges become dull with use. They have a hardness of 3 to 4 on the Moh scale. These observations together with the rather poor occlusion of turtle beaks and the fact that sea turtles have rarely been seen in the vicinity of deep sea moorings place them low on the list of suspects.

4.4. Environmental factors and fishbite.

Two conditions must obviously be met if a deep sea line is to be bitten:

1. The line and the biter must get together.
2. The biter must be stimulated to attack, unless like Pac-Man it just takes a bite at everything that comes along.

4.4.1. Getting together.

At first thought, a small, black, inert plastic line may seem to be a sorry bait, but consider its history as part of a moored array. Before the line even gets into the water, the interest of marine organisms has been aroused on a massive scale. A 1000 ton ship ploughs its way to the mooring site expending energy in stirring up the water at the rate of 2000 horsepower. It is a mixture of steady tones, swishes, splashes, and thumps. Tastes and odors are strewn along the way as fouling on the ship's bottom is washed. If garbage is thrown overboard it adds to the chumming. By the time the mooring site has been reached, signals of sight, sound, and pressure fluctuation have heralded some unusual event and a trail of chemical clues may have been established for miles. If there are phosphorescent organisms in the area, the ship's wake may be lighted as well.

When the ship has reached its station, patterns change. Noise level may subside and turbulence is less. Instead of a long and narrow path of ship noise, such signals now radiate in all directions. Chemical concentrations build up under the ship, and if there is an appreciable current they will, of course, be carried some distance downstream. If fish have been following the ship's wake, there is a chance to catch up.

At night, working lights are an attraction to squid and small fish which in turn excite the interest of biting predators.

During deployment of a mooring, there are some additional attractions. If it is a buoy first mooring, there will be irregular noises as the buoy goes overboard, then a period when line and instruments are paid out. To keep the array from tangling, the ship will be moving slowly, at perhaps 3 knots. Biting fish which have been alerted may find targets at this time, especially if there are bright and/or light colored items in the line. Figure 1.5 shows the result of an attempt to bite a white spacer in a towed acoustical cable. Fishermen have long used a technique like this, which is called "trolling." Moving parts are also attractive. Savonius rotors, vanes, and small propellers become targets.

After deployment and while the moored array is on station, algae, goose barnacles, hydroids, and bryozoa grow on parts in the photic zone, down to 100 meters or more. Below, in the dark, gelatinous organisms, such as siphonophores, often become entangled on the line. If they are or become phosphorescent and if there is an appreciable current at the site, the line will be lighted. If the line strums, in a current, it may announce its presence.

When the line is hauled, conditions are similar to those at the time of setting with two added features. One is the presence of organisms on the line which add to the baiting process as they are dragged through the water. The other is the disturbance of a community of fish and other organisms which was an orderly establishment while the line was moored, but which now becomes a scramble of baits.

From the foregoing account, it must be evident that the process of operating a deep sea moored station gives rise to a lot of stimuli over an

area that can be miles long and many meters wide.

How effective are the various signals in attracting biters? A full understanding of the sensitivities of fish and their motives is still in the making, but some useful information has been developed. It is known that sharks and bony fish have in varying degree, capabilities for detecting and responding to sound, pressure gradients, light, odor, taste, mechanical touch, temperature, electric fields, and magnetic fields.

4.4.2. Attraction and attack stimuli.

4.4.2.1. Chemical attractants.

Taste and odor are important attractants with a variable range of effectiveness (Hodgson and Mathewson, 1978). Sharks are attracted to baits such as fish and lobster, especially if they are broken up to allow soluble materials to diffuse into the water. In attempts to identify exact substances which were effective, tertiary amines, and amino acid mixtures as well as TMAO-glycine mixture have been tried and found attractive to lemon, nurse, and sharpnose sharks.

The range of effectiveness of chemical attractants is governed by passage through the water or if the source is stationary, by the direction and speed of water currents streaming past it. Lemon, nurse, and sharpnose sharks have been observed to become oriented in the presence of a chemical stimulus and to follow it to its source.

4.4.2.2. Audio-mechanical signals.

Sharks and bony fish have several ways of sensing audio-mechanical disturbances in the water. One is hearing which enables them to detect

sound waves. A second is the lateral line organ which responds to displacements in the water, and a third involves the tactical sensors in the skin. The swim bladder, which is found in bony fish but not in sharks may also play a role. Researchers have had difficulty in clearly separating the roles of the different organs in sensing acoustic-mechanical signals. From the standpoint of biting risk to moored arrays, such a distinction is probably academic. Suffice it to say that overall fish seem to be well equipped to handle such environmental information. Answers are needed to the following questions:

1. What kinds of acoustic-mechanical signals elicit responses from biting organisms?
2. Over what range of distances are acoustic-mechanical signals effective?

Sounds with frequencies within the ranges 10 to 40 Hz and 800 to 1000 Hz have been found to cause reactions in sharks (Hodgson and Mathewson, 1978). Lower frequencies were more attractive than higher frequencies. Pure tones were not effective at any frequency, but pulsed tones caused attraction especially if irregularly pulsed. Several species of sharks, silky, oceanic white tip, tiger (Galeocerdo cuiveri), blue, and mako, which have been implicated in biting of mooring lines, were attracted to low frequencies of pulsed sound from an underwater speaker. On approach to the sound source, some sharks exhibited "hunching" behavior and several bit the sound source. However, they learned rapidly, within about one hour, to disregard stimuli which were unproductive.

To produce a response in both sharks and rays, sound level must be in the order of 15 to 25 dB above ambient noise. Both kinds of elasmobranchs

were able to orient themselves with reference to the sound source and go toward it. Changes in loudness were significant. Gradual increase was apparently interpreted by sharks as a normal phenomenon indicating approaching nearness to the source. Sudden increases of 15 to 20 dB, on the other hand, produced a startled reaction followed by flight in both sharks and bony fish. Both returned to normal activity within a short time, but the teleosts adjusted more rapidly. Repetition of a loud noise at 5 to 10 minute intervals resulted in attraction of sharks.

In addition to the above work with captive animals, there has been a lot of experience with free-ranging sharks, both on the part of people who wanted to catch sharks and people who did not want the sharks to catch them. From this source there is general agreement that sharks are attracted by sounds made by wounded, struggling fish or by splashing, struggling people in the water. South Sea islanders use this knowledge to lure sharks with rattles of broken coconut shells soused up and down at the water's surface. Sudden loud sounds such as shouts, banging on boat hulls, and explosion of cherry bombs have also been used. There is general agreement that sharks will respond to sudden loud noise, but there is a divergence of opinion as to which way they will go!

On the question of distance over which acoustic-mechanical signals are effective, more precise information is needed. As noted by Hodgson and Mathewson (1978), distance over which sharks either have been or are estimated to have been attracted by sound sources are as follows:

Sound	Effective distance (meters)
1. Pulsed sound, 1000 Hz	180
2. Low frequency sound	Several hundred
3. Biological sound of interest to sharks	less than 100
4. Cherry bomb M-80	"long distance"
5. Limit of lateral line sensitivity to pressure fluctuations	250
6. Underwater vision of human observer	15 to 25

Obviously more precise data would be helpful.

Many of the data on effective range of acoustic-mechanical signals have been derived using visual sightings of attracted fish. Because of back scattering, turbidity, and low light intensities, the range of human sight is sharply limited underwater. A common result is that sharks which have been attracted appear "suddenly" at close range. A telemetering device which would get a true measure of the whole distance over which a fish's response has taken place would be helpful.

4.4.2.3. Visual stimuli.

Eyes are well developed in sharks and in many bony fish, but the role of light in location and capture of prey is not completely understood. Sight in water varies in several respects from sight in air.

Consequently, one cannot transfer the usual human experience with seeing in air to understanding the sight of fish. From laboratory studies (Levine and MacNichol, 1982) it is known that fish eyes are far from primitive, and hence, must play an important role in the lives of their owners.

As a visual medium, water has limiting characteristics. One is selective absorption of wave lengths. Fresh or salt water containing little organic matter absorbs violet and red wave lengths more than the intermediate wave lengths. The remaining light appears to be blue. As a result, blue wave lengths of sun light may penetrate to a depth of 75 meters, whereas red and violet light are eliminated by the first 25 meters of water. Coastal waters containing yellow-green phytoplankton and dissolved organic matter absorb all wave lengths of light more strongly, and colors differentially. Such waters often look green due to strong absorption of the blue and violet components of sunlight. Below 100 meters, visual darkness prevails.

Absence of some wavelengths means that some objects may have colors that are not perceived in their natural habitat. For example, fish caught in deep, clear water and hauled out into the air may be seen to have a bright red color. At home, underwater, however, they would appear to be either black or very dark blue.

In addition to wave length absorption, light which passes through water is also subject to scattering by the water molecules and by suspended particles. As a result, the water itself appears to be a source of light, a phenomenon called "background space light." Fish must distinguish food, predators, and mates against this background space light. Visibility is determined by a match of color, and intensity as

seen by the eye of the fish. A close match results in "invisibility." Variations in either wave length or intensity should result in an object being seen. Another effect of back scattering is to limit the distance over which underwater vision is effective because the path which light must travel from object to eye is longer than the geometrically straight line from object to eye.

From records of practical experience, there is some uncertainty about the utility of visual stimuli in attracting or repelling fish. Bright objects, especially if they are moving erratically, are thought to be attractive. Black seems to have little attractiveness. Records indicate that sharks are either indifferent or somewhat repelled by black objects. On the other hand, international orange seems to be attractive to sharks. Another source (Hodgson and Mathewson, 1978) states that oceanic sharks were attracted to fluorescent orange and yellow survival gear, with the exception of silky sharks which avoided the orange.

4.4.2.4. Electromagnetic fields.

Sharks, rays, and catfish have an electromagnetic sense which causes them to attack and bite sources of minute electric currents. The phenomenon was first observed by Parker and van Heusen in 1917. They found that a catfish (Amiurus nebulosus) would bite a metal rod when it came near, but it was not affected by a glass rod unless it actually touched the catfish. The attraction was identified as an electric current of less than 1 microampere. Currents greater than 1 microampere were repellent. Later, Kalmijn (Hodgson and Mathewson, 1978) elicited a feeding response in both a shark (Scyliorhinus canicula) and a ray (Raja

clavata), with currents of 4 microamperes, which is the same order of magnitude as the current around a live fish (plaice). Both alternating and direct current were effective. Similar results were obtained with the lemon shark (Negaprion brevirostris) and the smooth dogfish (Mustelus canis).

The organs sensitive to electric currents were found to be the ampoules of Lorenzini. Range of effectiveness was measured up to 25 cm and estimated to have a working range of up to 2 meters. It is apparently a homing mechanism which causes attack and biting at a range too close for effective use of eye sight. It is not necessary to have an organic source for biting to take place. A metal rod in the earth's magnetic field and moving relative to a shark provides enough current to stimulate attack.

4.4.2.5. Temperature.

Present information indicates that with reference to temperature there are at least two distinct patterns of fishbite distribution.

Where sharks are the prevalent cause of fishbite, there is a temperature below which biting is unlikely to occur. Cousteau (1970) states that below 20°C lemon sharks stop feeding and therefor risk of biting is less. Schultz, Gilbert, and Springer (1964) place the limiting temperature at 18.3°C. The concern of these authors has been mainly with biting attacks on humans, but presumably the activity of sharks toward other targets would be similar.

The distribution of sharks is closely allied to temperature and in the case of white tip sharks with high salinity, 35.5% minimum. These factors are closely related to latitude and hence it is possible to

delineate regions of the world ocean with reference to fishbite hazard due to sharks. Backus, Springer and Arnold (1956) place the northernmost limit of the white tip shark's known range at $40^{\circ}43'N$ (at $66^{\circ}60'W$).

Where fish other than sharks are concerned, the same temperature limits do not apply. For example, Sudis hyalina at 900 to 1000 meters off the coast of Bermuda is at the bottom of the thermocline biting rope at a temperature of $7.5^{\circ} - 8.0^{\circ}C$. Aphanopus carbo, which was identified by LeGall (1972) as an organism which has bitten deep sea mooring lines, has a preferential temperature range of $8.5^{\circ} - 13^{\circ}C$. It has been caught at depths varying from 1000 to 1100 meters to 250 meters in more northerly waters. A. carbo, although it was originally discovered to be a line biter south of Cap St. Vincent, might also be encountered as far from the equator as the northwest coast of Scotland.

CHAPTER 5 - PREVENTION AND CONTROL OF FISHBITE DAMAGE

This chapter reviews the preventive methods which can be used to reduce the incidence and or the severity of fish attacks and the curative methods which hopefully can protect mooring lines from the mechanical damage inflicted by fish bite.

5.1. Preventive methods.

Preventive measures include selecting sites outside of the "danger zone," reducing the attractiveness or incentive mechanisms, and the use of repellents whenever practical.

5.1.1. Operational limits.

Common sense would dictate to stay out of the Fishbite Zone wherever possible. This approach of course is very restrictive. It should be followed cautiously given the lack of fishbite data in regions and depths other than those included in our definition of the Fishbite Zone. Even then, one should recognize that the zone boundaries are not static, as evidenced by the fluctuations of the Gulf Stream paths shown in Figure 5.1.

As it flows along the East Coast of America, thence turns east to cross the Atlantic, the Gulf Stream carries water of higher salinity and temperature than the surrounding water. It also contains marine organisms which follow the course of its erratic travels. Table 5.1 illustrates how the Gulf Stream's variable path may influence the incidence of fishbites at a given location.

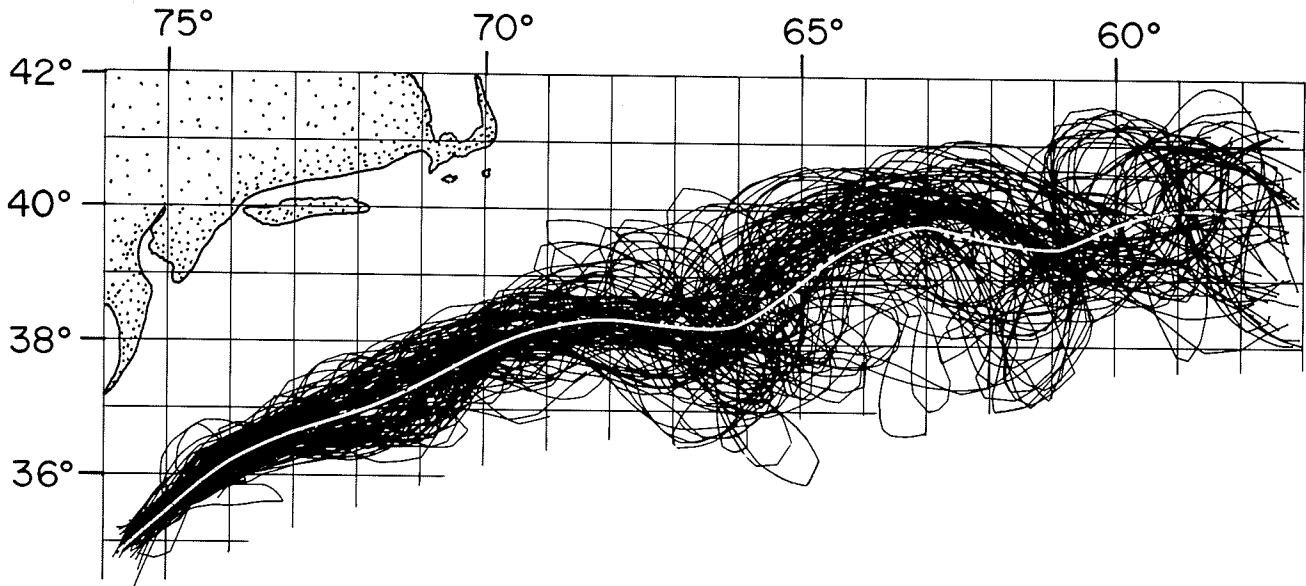

Figure 5.1 Gulf Stream northern edge superimposed on one another (April - December, 1982). The white line indicates the mean track (P. Cornillon, 1986).

Table 5.1

Yearly incidence of fishbite at Site D (40°N, 70°W)
(Northern boundary of the Fishbite Zone)

Year	Number of Moorings set	Number of Moorings bitten
1968	20	0
1969	14	6
1970	8	2
1971	11	1
1972	17	1
1973	6	1
1974	5	0

The well known summer migration of subtropical species, including biters such as sharks and bluefish, to the Coast of New England is another example of the permeability of the Fishbite Zone boundaries.

5.1.2. Reducing factors of attraction.

As previously mentioned, factors which attract predators and may increase the chances of fishbite include visual stimuli, vibrations, odors and taste.

The experience of fishermen who try to encourage fishbiting by the use of flashy lures is helpful if applied in reverse. Eliminating the metallic shine of mooring components such as cable connectors by taping or spray painting should be helpful. It probably would have prevented the damage on the acoustic array depicted in Figure 1.5, which occurred 20 meters below the surface.

During deployment, which may typically last several hours, the entire mooring line is slowly towed on the surface. During that time all mooring components, the deep ones as well as those who eventually end up in the photic zone, are exposed to the curiosity and possibly the attack of pelagic fish. Obviously mooring lines and their inserted instruments should have dull, unattractive colors with minimum contrast against the environment. Greenish grey, light blue, and black are indicated.

The low frequency vibration of small, taut mooring lines induced by currents is a well known and documented phenomenon. Vibrations in the range of 10 to 100 hertz has been reported to be attractive to sharks, especially if they are irregularly pulsed. Mooring line strumming can be effectively reduced or entirely suppressed by inserting tear drop shaped

fairings which orientate themselves downstream of the line and act as a separation plate, thus preventing the formation of vortex shedding. Ropes equipped with plastic ribbons or protruding "hairs" will also be free of flow induced vibration. The need exists for demonstrating through controlled experiments that fishbites indeed are reduced by inhibiting strumming.

As time passes, mooring lines and their instrumentation deployed in the photic zone will accumulate layers of marine growth and become fouled by marine organisms. This fouling process results in a sustained food chain that rapidly develops at the mooring site, thus increasing the possibility of fish attacks. Antifouling treatment of buoy hull and all mooring components down to at least 100 meters is the obvious remedy to the problem. Widely used copper base antifoulants, such as cuprous oxide or copper naphthenate, can be used effectively on buoy hulls. However, the small surface area of a mooring line immersed in the ocean makes it difficult to maintain an effective concentration of standard chemical repellents over any length of time. Slowly dissolving organo-tin compounds could be applied in coatings, or better yet, imbedded in a semiporous jacket extruded over the rope. Then again, their potential as long term antifoulants for mooring line applications should be investigated in controlled, deep sea experiments.

Another form of fouling occurs on deep sea lines way down past the photic zone. There, long and gelatinous organisms, mostly Siphonophores, drifting with the currents, become entangled with the mooring lines. Their taste, odor, and or phosphorescence entice deep sea predators to attack, and the line is often bitten and damaged in the process. There is little that can be done to prevent such random fouling.

As already noted, elasmobranch fish are stimulated to attack at close range by very weak electric currents. The standard practice of covering metallic ropes and cables with a plastic jacket is probably the most efficient way to reduce or suppress this incentive.

The fascinating behavior of sharks has been studied by many researchers and various means for repelling sharks or deterring them from attacking have been investigated and reported (Prindle and Walden, 1975). These means include chemical repellents, acoustical and electrical fields and physical barriers. All these techniques require chemical supplies and power resources which cannot be stored or provided by standard, state of the art mooring technology.

At present, practical methods for control of fishbite by repelling deep sea biting organisms are not available. Therefore, when lines are to be exposed to the ocean environment within the Fishbite Zone, they must have sufficient structural resistance to biting attack to survive their expected service life.

5.2. Curative methods.

Curative methods, that is these techniques which hopefully immunize and protect mooring lines from failure due to fishbites, include the use of metallic ropes, the use of large diameter non-metallic ropes, and barriers of metal or hard plastic placed over non-metallic ropes.

5.2.1. Use of metallic ropes.

Over the last two decades ropes made of steel wires have been extensively used to provide fishbite protection throughout the Fishbite Zone. Long term surface and subsurface moorings routinely use wire ropes

from the surface down to a depth of 2000 meters.

Wire ropes have excellent strength to drag ratio. They are easy to handle and their cost is relatively low. However, they are susceptible to corrosion and fatigue and their weight is a penalty. Jackets of plastic materials (polyurethane, polyethylene, polyester, etc.) are often extruded over wire ropes. These jackets provide a water barrier which greatly reduce the corrosion fatigue of wire ropes and substantially increase their useful service life (Morey, 1973).

Systematic endurance tests performed at sea with bare and jacketed wire rope specimen loaded to approximately 20% of their breaking strength have shown that bare ropes typically fail after a few months, whereas the jacketed version of the same specimen would invariably last five to six times longer. Jacketed specimen with simulated fishbite damage in the jacket would last only half as much as the undamaged specimen (Berteaux, 1969).

Figure 5.2 shows an interesting collection of metallic wire fracture faces which can be used by the readers to help identify the cause of a particular wire rope failure.

5.2.2. Use of large diameter syntactic fiber ropes.

Early experience with synthetic fiber mooring lines of large diameters (one inch or more) seemed to indicate that these larger ropes were less susceptible to failure from fishbites than the smaller ones.

However, as more and more ropes were sent to the laboratory for analysis, it became evident that large rope often had many bitten yarns. Some even had failed entirely due to repeated biting.

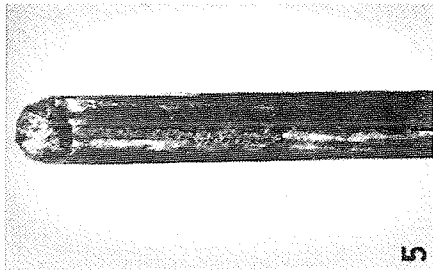

5
FATIGUE
(jagged type)



4
FATIGUE
(square type)

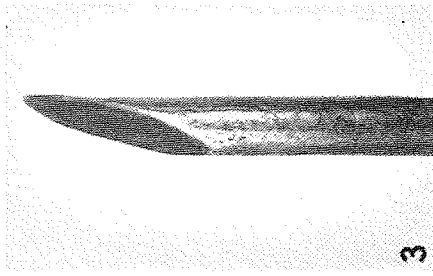

3
ABRASION

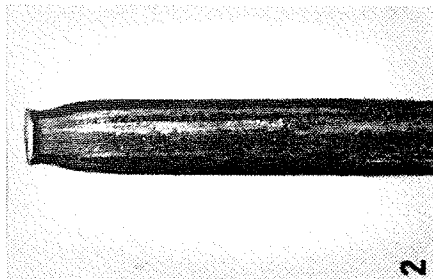

2
TENSION (cup)

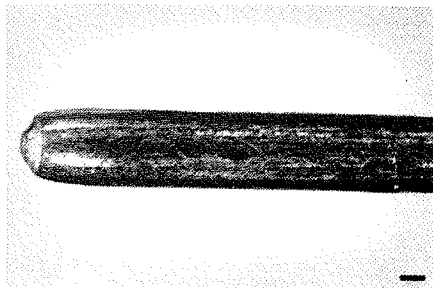

1
TENSION (cone)

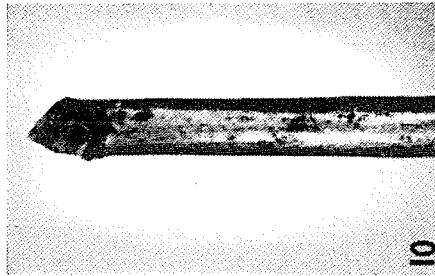

10
CUT or SHEAR

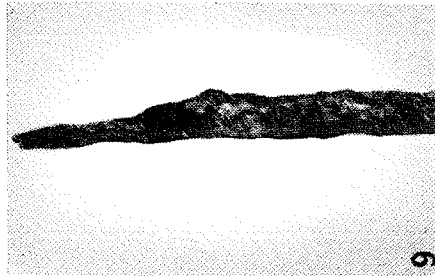

9
CORROSION

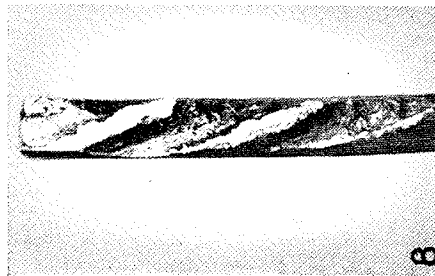

8
FATIGUE
and NICKING

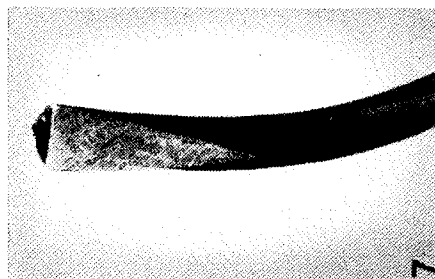

7
FATIGUE
and WEAR

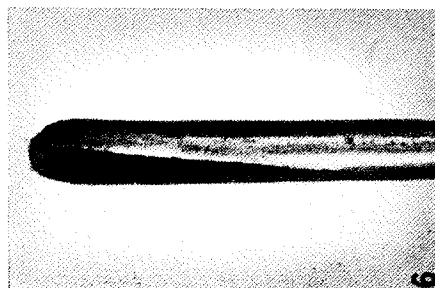

6
TENSION
and WEAR

Figure 5.2 Wire fracture faces.

The greater survival rates of larger ropes result simply from their bulk. A few cuts cannot diminish the rope strength to the point where it would fail in tension. Size does not deter biting but it certainly helps in keeping the moorings integrity.

However, the use of large ropes in long mooring lines remains impractical as bulk, drag, and cost increases and become prohibitive.

As a matter of fact, with the introduction of high tenacity fibers such as Kevlar, the trend is to use smaller rope sizes. If the smaller, lighter Kevlar lines, with a strength comparable to wire ropes of the same size, could be adequately protected from fish attacks then they certainly would take the place of wire ropes in most mooring applications.

5.2.3. Protecting non-metallic ropes.

As a group syntactic fiber ropes have attractive mechanical characteristics. They do not corrode nor deteriorate appreciably in sea water. Their strength to immersed weight ratio is excellent. They are easy to handle and terminate. However, to be useful within the Fishbite Zone they must be protected against fishbites.

Early attempts at providing a measure of protection with the help of metallic or plastic armors were unsuccessful. It soon became apparent that a need existed to better understand the fishbiting process. If it could be quantified then perhaps its effects could be reproduced in the laboratory. A test procedure could then be devised to systematically probe and compare protective candidate materials.

5.2.3.1. Early attempts.

Steel armoring in the form of tapes or meshes must remain of modest

weight, otherwise one may as well use a wire rope of the same strength as the fiber rope to be protected. Small wires have a tendency to corrode faster. When broken they tear and wear the fibers. Unless the braid is very tight, tooth points will slip between the wires and cut the underlying fibers. This form of protection did not appear very practical.

A second approach was to encase syntactic fiber lines in a tough envelope or tubing of plastic. Several hard, cut resistant materials were used. Lengths of plastic armored polyester and nylon ropes were then deployed on deep sea moorings and their performance evaluated. Polycarbonate, rigid polyvinyl chloride, and acetal copolymer have been tested in this way. Each has been found to have its particular shortcoming. Polycarbonate was destroyed by stress crazing. Rigid PVC broke up when handled on deck at winter temperatures. Acetal copolymer was notch sensitive, so its use was limited to one mooring because nicks produced by fish teeth led to a later cracking when the line was flexed. The outcome of such tests was valuable in pointing up characteristics which would be necessary in a good armor, but the method of testing at sea was very slow and expensive. These early efforts have been reported in detail in "Deep Sea Lines Fishbite Manual" (Prindle and Walden, 1975).

5.2.3.2. Fishbite process.

As previously mentioned, close observation reveals that fishbites appears as slanted or skew cuts produced by a very sharp and sometimes scalloped or serrated edge.

Factors operative in the process of cutting any given material are illustrated in Figure 5.3. Factors which increase the cutting force, that is the force required for the cutting tool to penetrate a given distance,

are a large edge radius (dull tool) and friction between the blade and the material being cut.

Factors which reduce the cutting force are a large clearance angle (ease of penetration, no binding), a small sharpness angle (fine blade), a small edge radius (sharp edge) and often the skew angle or the angle between the blade and the surface being cut. Fiber tension will reduce contact between the walls of the cut and result in less blade binding and an easier cut.

As cutting tools, fish teeth, notably those of sharks, compare favorably well with the sharpest man made blades such as the blades of razors and utility knives. They have similar hardness and comparable edge radii (0.025 mm). Shark teeth however, are more brittle than steel. The cutting force of fish jaws is not a well known quantity. However, a value as high as 300 lbs. has been measured for a medium size dusky shark (Carchairnus obscurus) and reported by Gilbert, et al., 1967.

Thus fish teeth have the sharpness and the hardness required to be highly efficient cutting tools. Fish jaws can develop large cutting forces which translate in large pressure stresses to puncture and cut fibers. Tension in the fibers and the curved surface of the ropes further facilitate skew cutting. These facts can and have been used to design tools and techniques for reproducing fish attacks in the laboratory.

5.2.3.3. Armor material test and evaluation procedure.

A sensible procedure to evaluate the fishbite resistance of armor materials should 1) reproduce the cutting mechanisms observed on damaged ropes 2) be easy to implement and 3) hopefully relate to the standards commonly used to describe the mechanical properties of plastics.

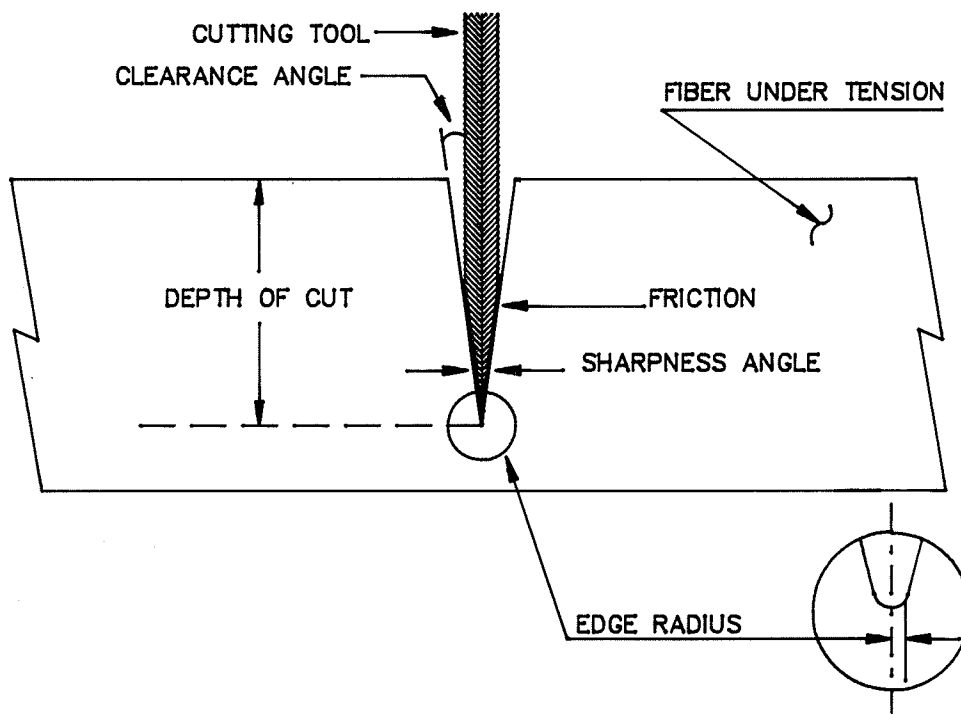

Figure 5.3 Mechanics of cutting (Barkas, et al., 1932).

The two main modes of fishbite damage are puncture and cutting, both often occurring simultaneously. A puncture test could give an idea of the force required for a triangular, natural or artificial tooth to penetrate a given distance into the material. A cutting test would yield the force required for a blade to partly or completely sever a given specimen. Puncturing and cutting tools could be used to impart the same type and amount of damage to different armors and rope specimen. The remaining strength of the specimen could then be established and compared.

Puncturing test equipment and procedures. The puncturing or stabbing tool presently used is shown in Figure 5.4. It consists of a frame holding the specimen, a stabbing rod with a knob and a tooth, and a dial

micrometer. Force is measured by the deflection of the frame as the knob is turned and the tooth forced into the specimen. The relation between force and deflection is obtained and periodically checked by weight calibration.

The stabbing point can be either shark teeth or teeth from saw blades. Shark teeth being brittle and difficult to obtain, teeth from bow saw blades are frequently used. With a small amount of filing to round off the point and some shaping of the sides a reasonable facsimile of a carcharhinid shark tooth can be produced. A penetration mark 1/8 in. away from the point is usually engraved on the tooth. The tooth is then cast in epoxy and mounted on the stabbing rod.

To perform a puncture test the sample is inserted in its holder, the tooth is brought close to the sample surface and the dial is set to zero. The tooth is then forced all the way to the engraved mark. The dial reading is then noted and translated to units of force using the instrument calibration data.

Cutting equipment and procedures. The force to completely sever armor materials and/or armored rope specimen is best measured using a Universal Testing Machine in the compression mode. As shown in Figure 5.5 a typical set up would include a blade holder mounted in the moving platten and a specimen holder fixed to the base of the machine. Because sample bending would cause the blade to bind, sample holders must be designed to provide strong support during cutting. The gap between the supporting blocks must be as small as possible, typically the width of the blade plus tolerances. Blades of utility knives (Stanley #1992) are routinely used.

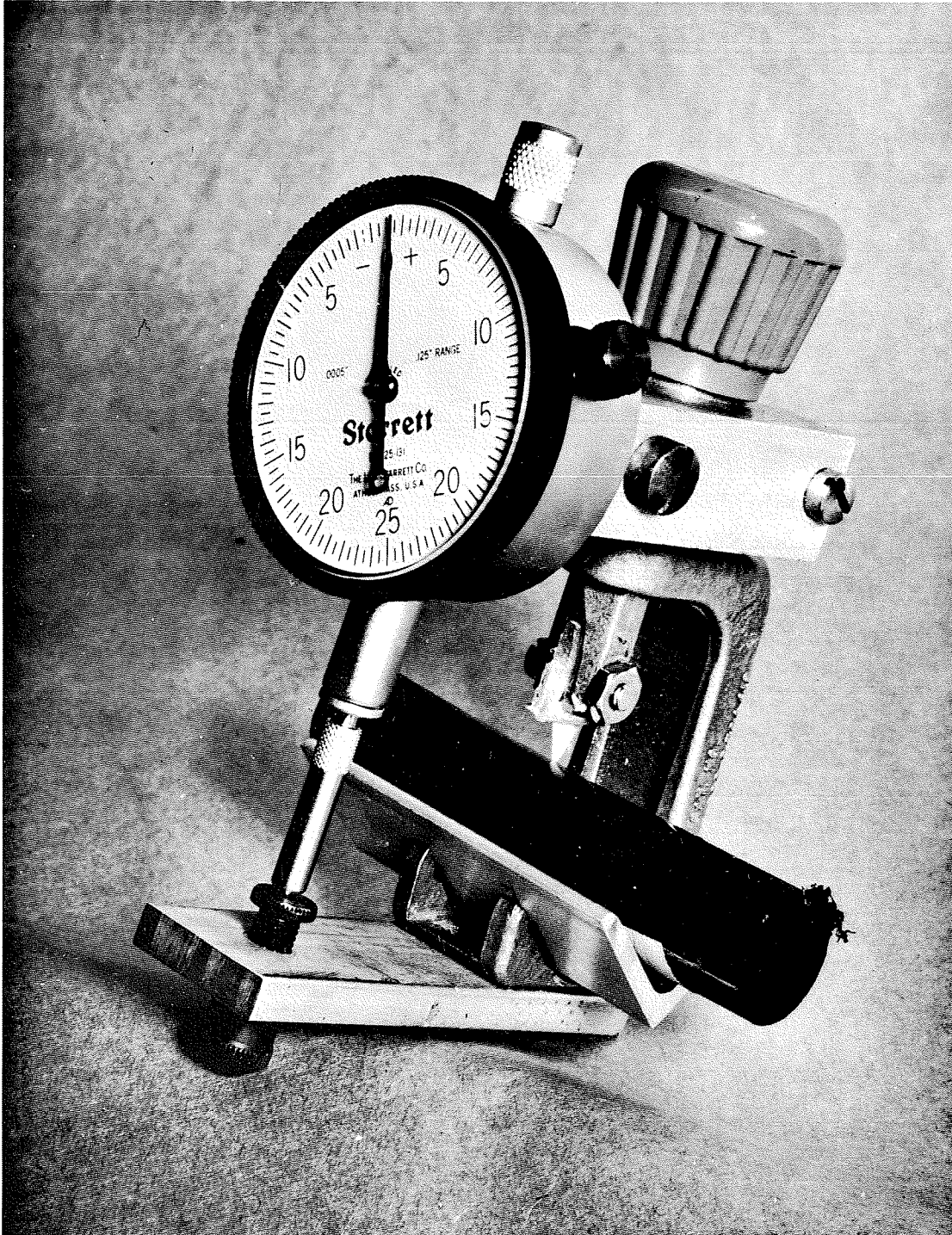

Figure 5.4 The Bitometer (Stimson and Prindle, 1972).

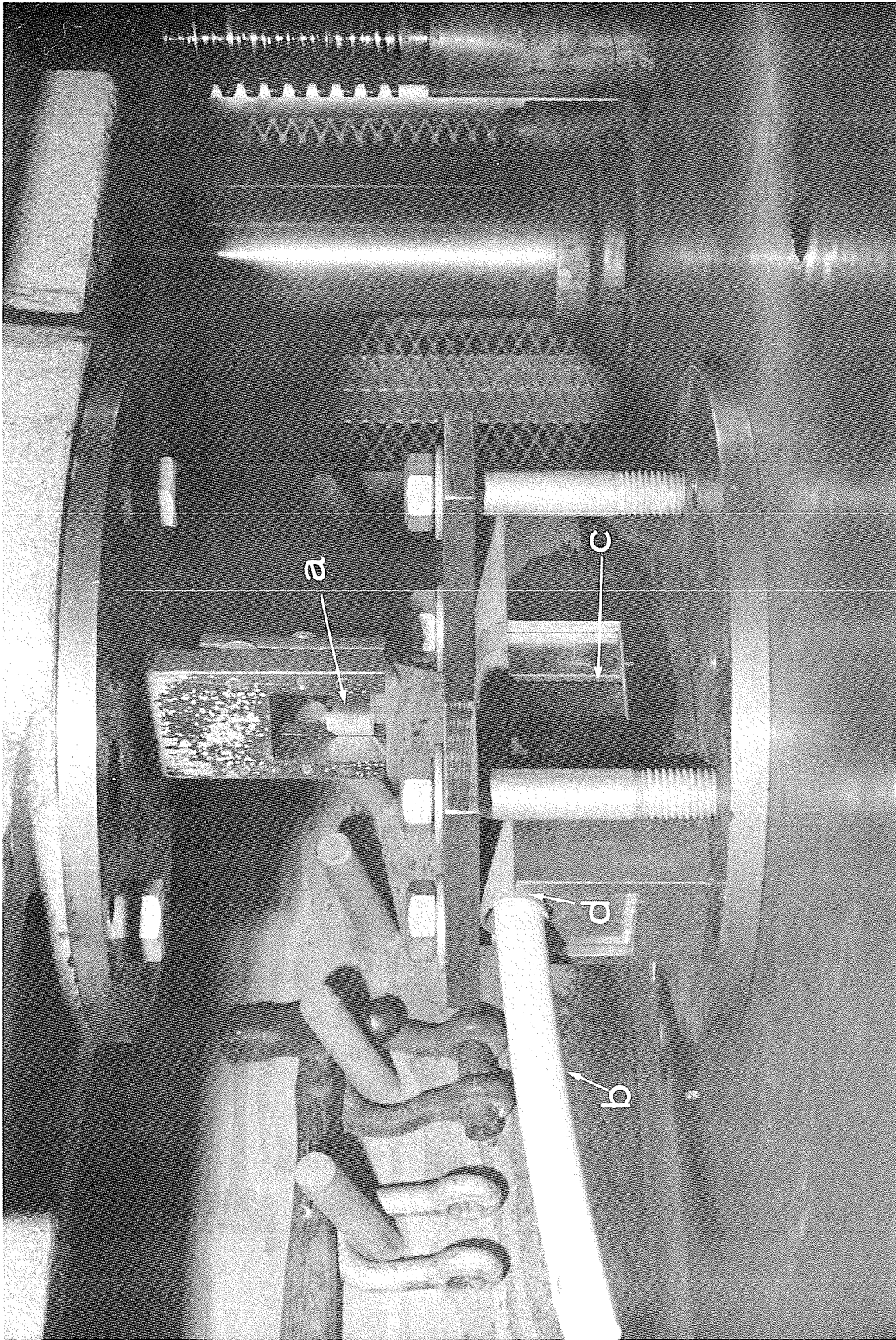

Figure 5.5 Armor specimen cutting set up. a: Cutting blade b: Sample holder
c: Gap between supporting blocks d: Sample holder

To perform a cutting test a new blade is inserted in the blade holder and the specimen supporting blocks are located and fastened to the base. The blade is then carefully lowered to check that the cutting path is free of obstacles. The gap is checked and adjusted as need be. The blade is then brought up, and the sample is placed into the 'V' grooves of the supporting blocks. The blade is then brought down again and forced to cut the sample at a speed of 20 inches/minute (0.508 m/min.). The maximum force occurring during the cutting operation is registered on the machine dial. Several samples (2 to 5) should be cut for statistical significance, using a new blade for each cut.

Durometer D tests. The stabbing and cutting tests just described are attempts to simulate the kinds of damage which mooring lines would encounter in service. These tests are not in general use in the plastic of the cordage industries. An attempt was therefore made to see whether a test which is more widely recognized could be related to these specialized procedures and so facilitate the screening of candidate armor materials. To this end the durometer test using the shore D scale was found useful. It, like the Bitemeter, measures the force required to drive a conical point of hardened steel into the surface of a specimen.

To determine the correlation between these test methods, standard test bars of plastic were subjected to stab, cut, and durometer D tests. Data obtained are shown in Table 5.2.

Table 5.2

Cut, Stab, and Durometer Data for Various Armor Candidate Materials

Generic name	Trade name	Cutting Force (lbs)	Stabbing Force (lbs)	Durometer Shore D
Acetal copolymer	Celcon M25-04	52	120	84
Acrylic/PVC alloy	DKE 450	62	147	83
Acrylic/PVC alloy	DKE 475	68	119	82
ABS*	Kralastic			
	SR-S 1801	39	73	77
Cellulose butyrate	Tenite butyrate	50	94	80
Fluoropolymer E-CTFE	Halar 300	56	79	76
Fluoropolymer	Tefzel 280	41	72	74
Ionomer	Surlyn 1801	23	46	62
Nylon	Capron 8207	59	139	85
Nylon	Zytel St 801	35	63	78
Polycarbonate	Lexan 101-111	73	149	85
Polyethylene	Super Dylan 5900	17	37	66
Polyphenylene oxide	Noryl SE 100	57	119	84
Polyterephthallate	6P50+EP-16-1(80-20)	45	98	75
Polyterephthallate	6P50+EP-16-1(60-40)	36	75	75

*Acrylonitrile-butadiene-styrene

This data clearly indicates that the three tests follow the same trend. To better visualize the relationship between the tests, two regression plots of Durometer D test data versus stab test and cut test data were made (Figure 5.6 and 5.7). In both plots the Durometer numbers cover a narrower range than the numerical values of the other test variables, but there appears to be a strong correlation. If one does not set the limits too rigidly, it seems that the Durometer shore D numbers can be used as a good indicator for the preliminary screening of plastics.

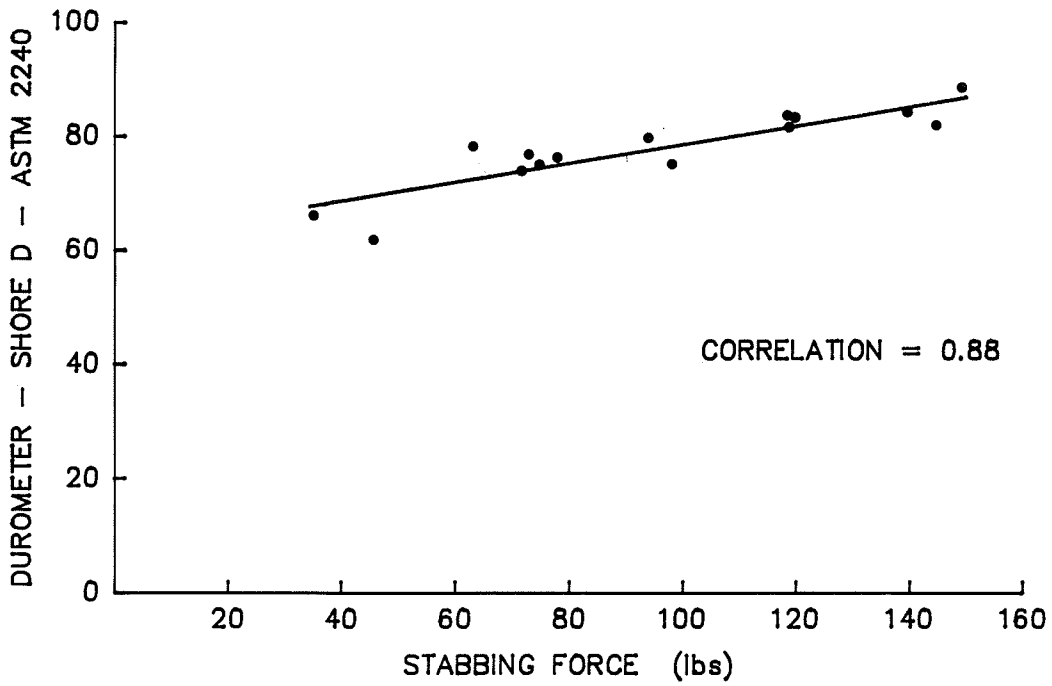

Figure 5.6 Durometer D versus stabbing force.

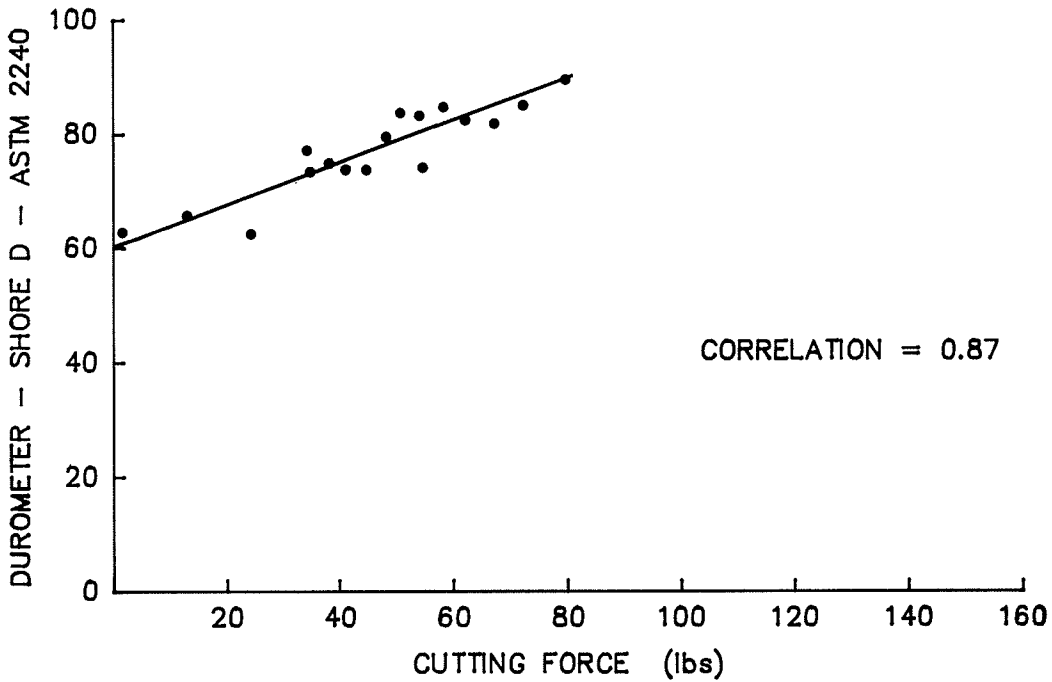

Figure 5.7 Durometer D versus cutting force.

In addition to penetration resistance, it is important that armor materials have resistance to propagation of cuts and cracks from the original site of damage. The Notched Izod test (ASTM test # D256) has been found to be a useful indicator of this property. A value less than 5 ft-lbs/in. generally indicates a material which is not tough enough for a good fishbite armor. If possible, a Notched Izod value of more than 10 ft-lbs/in. should be sought.

5.2.3.4. Physical and mechanical properties required for armoring materials.

Certainly no material exists today which can protect a fiber rope from the furious bites of a large shark in the throws of a feeding frenzy. Fortunately pelagic sharks spent most of their time near the surface with occasional deep sea dives. What is required is a jacket material, or armor which can reasonably protect the ropes in the majority of cases: inquisitive bites, nibbling, and the constant attack of the smaller and deeper benthic species. If the use of metallic mooring lines could be limited to the first few hundred meters of the water column, the weight saving would incite and permit the development of novel mooring applications.

The tools and test procedures just described were exercised on existing ropes and on common jacket materials such as high density polyethylene and polyurethane. The resistance of "hard to cut" plastics, either in tubular or standard test bar form was also investigated.

As a result of these numerous tests reasonable numbers emerged to quantify the penetration and cutting resistance requirements for "good" jacket and armor materials. These numbers are:

- . Resistance to penetration better than 75 lbs.
- . Resistance to cut better than 38 lbs.
- . ASTM Durometer Shore D 75 or better.

These numbers express a compromise between polyethylene which has been widely used but will not give enough protection under severe attack and some other materials which are tougher but tend to be unmanageable. Polycarbonate is an example of the latter. It successfully resisted biting (Stimson and Prindle, 1972) but was stiff and subject to stress cracking. The force to stab a test bar of polyethylene was measured as 37 lbs. and the force to stab polycarbonate, 149 lbs. The specified limit (75 lbs. to stab) is roughly twice the force required to penetrate polyethylene. The limits of 38 lbs. force to cut and 75 Shore D Durometer, are the corresponding values determined from the equations of the lines drawn in Figures 5.6 and 5.7 which relate stab and cut forces to the Durometer test. Conveniently, it turns out that the numbers for steel tooth stab and Durometer D are both 75 and force to cut is almost exactly 1/2 as large.

In addition to being difficult to cut, "good" armors should be easy to extrude over the ropes to be protected. They should not impair the usefulness and ease of handling of the original rope by undue stiffness, and they should resist the environmental conditions usually encountered in mooring line service.

No material tested to date possesses all properties to an ideal degree, but as progress has been made from one experimental armor to the next, a picture of the desired jacket material has begun to emerge. It must be more cut-resistant than polyurethane and high density polyethylene; less brittle than polyvinyl chloride (PVC); not subject to stress cracking like polycarbonate; and more resistant to cracking when notched than is acetal copolymer.

A set of requirements based on our present experiment and research of the field for candidate jacket materials is outlined in the data sheet shown in Table 5.3. This specification's primary purpose is to aid in the screening process of plausible plastics. It does not take into consideration all the information one should have before using a material on a line which is to be part of a deep sea mooring. In fact it would also be desirable to determine the properties of a candidate armor when saturated with water; to learn more of the effects of low temperature on its physical properties; and of course, to ascertain the probability of success in extruding it over a fiber rope. A material which satisfies the requirements of these armor specifications and then performs well under these latter considerations could certainly be considered for test and evaluation on a mooring line at sea.

The limits indicated in this fishbite armor specification represents what is thought to be reasonably ideal for armoring lines with diameters between 0.24 and 0.50 inch. Changes in size, particularly with larger diameter ropes, may yield somewhat different values. The properties listed are grouped into several categories. The first group relating to cut and stab forces is critical. Materials which fall below the indicated limits are not likely to make effective armors.

Table 5.3

Fishbite Armor Specification

PROPERTIES:	TEST	UNITS	DESIREABLE LIMITS	CANDIDATE ARMOR
<u>CUT RESISTANCE</u>				
FORCE TO CUT	DSLFM *	lbs.	38 min	
FORCE TO STAB: STEEL TOOTH	DSLFM *	lbs.	75 min	
DUROMETER	ASTM 2240	Shore D	75 min	
<u>TOUGHNESS</u>				
IMPACT, NOTCHED IZOD	ASTM D256	(ft)lbs/in	5 min	
TENSILE MODULUS	ASTM D638	(10 ⁵)lb/in ²	10 max	
ELONGATION TO YIELD	ASTM D638	%	10 min	
ELONGATION TO BREAK	ASTM D638	%	20 min	
FLEXURAL MODULUS	ASTM D790	(10 ⁵)lb/in ²	4 max	
<u>SPECIFIC GRAVITY</u>				
			1.50 max	
<u>THERMAL PROPERTIES</u>				
MELTING POINT		°F	**Varies	
EXTRUSION TEMPERATURE		°F	**Varies	
BRITTLENESS TEMPERATURE	ASTM D746	°F	0 max	
USE RANGE		°F	-40 to 120	
<u>ENVIRONMENTAL STABILITY</u>				
STRESS CRACKING			Excellent	
HYDROLYSIS			Excellent	
ULTRA-VIOLET RADIATION*			Excellent	
<u>RATING</u>				
* DSLFM = Deep-Sea Lines Fishbite Manual (Prindle & Walden, p.62, 1975) ** Related to thermal properties of other line constituents.				

The second group of tests under "Toughness" includes factors which bear on the capability of a material to absorb abuse and remain serviceable. In general, the higher the values the tougher the material, but difficulties are encountered if recommended values are exceeded. If tensile modulus is too high the armor will carry too much tensile stress as the line is loaded. Excessively high flexural modulus will make the line too stiff to handle. On the other hand, elongation should be sufficient so that the armor is not broken when the line is extended under load.

Specific gravity is a low priority item. From an ideal standpoint armor should not add to the weight of a line in sea water. Buoyancy might even be helpful. In terms of overall utility, specific gravity is not a limiting factor for most thermoplastics.

Under "Thermal Properties" melting and extrusion temperature limits are related to the thermal tolerance of the tensile fibers used particularly with reference to extrusion. "Brittleness temperature" and "Use range" govern the handleability of an armored line. In the water, deep sea lines are subjected to temperatures from -2°C to 27°C . However, they may be required to perform under a much wider range of temperatures when stored or handled on deck or on shore. Difficulties have been experienced when armored line were run over small diameter sheaves at low winter temperatures. A practical range of temperature requirements should span from a low of -40°C to a high of 50°C .

Environmental resistance is necessary if a line is to be used repeatedly. Resistance to stress cracking is essential. Hydrolysis and other effects due to water are significant in a material which is to be

used for long periods under water at considerable pressure.

Resistance to sunlight and oxidation are important if lines are stored outdoors, uncovered, or whenever they remain exposed to sun rays for prolonged periods. The susceptibility of polypropylene ropes to sunlight damage is well known. In general, carbon black has been successful as an ultra-violet light screen. It also has the added advantage of lowering visibility of lines used under water.

5.2.3.5. Candidate armor materials and techniques.

State of the art candidate materials which have been considered for use on fishbite armor include the following:

- . Acrylonitrile-Butadiene-Styrene (ABS)
- . Fluorocarbon
- . High density polyethylene
- . Polyester
- . Nylon 6/6 and nylon 6
- . Polyurethane
- . Acetal co-polymer
- . Polycarbonate

The relevant properties of these plastics are as shown in Table 5.4 together with their rating A, B, C as here defined:

- A. Good Passed all requirements; recommended for trial at sea.
- B. Fair Acceptance fell a little short of some requirements but
 have compensating properties and could be tried at sea.
- C. Poor Failed critical requirements; no further consideration.

In recent years a small number of syntactic fiber and wire ropes have been armored with thermoplastic jackets. Some of these materials are represented in Table 5.4. These ropes were tested in the laboratory and deployed at sea for varying lengths of time. Results from these tests are summarized in Table 5.5.

These results confirmed that the widely used softer materials i.e. polyethylene, polyurethane, and polyester are highly susceptible to fishbite damage.

Harder materials such as acetal copolymer and polycarbonate successfully protected lines from fishbites, but as already noted, they were rendered useless by their propensity to crack.

Nylons, with stabbing and cutting resistance somewhat less than those specified, appeared to provide adequate protection when deployed at sea.

In addition to these jacketing materials new metallic and non-metallic braids have been recently introduced and their laboratory evaluation is in progress.

Table 5.5
Fishbite resistance of some plastic jacketed mooring lines

MOORING LINE				LABORATORY TESTS				TESTS AT SEA			
MATERIAL	CONSTRUCTION	DIAMETER (inches)	ARMOR MATERIAL (THICKNESS)	LINE TENSION (lbs)	STAB (lbs)	CUT (lbs)	DUROMETER SHORE D	SITE	DURATION DAYS	RESULTS	
POLYESTER DACRON T68	PARALLEL YARN BRAIDED COVER	13/32"	NONE	0		14				ALMOST COMPLETELY SEVERED (SEE FIGURE 1.2)	
		(10.3 mm)		1200		2					
			ACETAL COPOLYMER (78 mils)	0	63	121	81	38°19'N 69°39'W	59	NO EVIDENCE OF BITES	
			NYLON 6/6 (63 mils)	1200	45						
KEVLAR	JETSTRAND	1/4" (6.4 mm)	NYLON II (RUFJN) (73 mils)	0	39	104				NOT TESTED AT SEA	
				1200	23	37	65	39°21'N 70°02'W	338	LIGHT FISHBITE ATTACK NO SIGNIFICANT DAMAGE	
NYLON	8 STRAND PLAITED	1/2" (12.7 mm)	POLYETHYLENE (WATER PIPE)				66	34°00'N 70°00'W	60	59 BITES ARMOR NOT PIERCED	
							75	35°00'N 70°00'W	45	178 BITES ARMOR NOT PIERCED	
								35°02'N 65°55'W	60	76 BITES ARMOR NOT PIERCED	
							64	40°12'N 66°35'W	(Towed at 4.5km)	SLASHES THROUGH POLYURETHANE	
GALVANIZED STEEL	3 X 19	3/16" (4.8 mm)	POLYURETHANE (88 mils)				66	39°09'N 69°59'W	106	50 BITES POLYETHYLENE ARMOR CUT THROUGH	
				POLYETHYLENE (70 mils)			78	38°03'N 68°54'W		MODERATE FISHBITE ATTACK NO SIGNIFICANT DAMAGE	
		3/16" (4.8 mm)	NYON ZYTEL ST801								

Based on the screening and test procedures just described, the candidate jacketing materials which exhibit the best potential as rope armors and deserve consideration for further evaluation at sea are the following:

Thermoplastics:

ABS - Uni-Royal, Kralastic SR-S-1801

Fluorocarbon - E.I. duPont de Nemours, Tefzel 280

- Allied Chemical Co., Halar 300 (Fluorocarbon E-CTFE)

Nylon 6 - Allied Chemical Co., Capron 8220

Nylon 6/6 - E.I. duPont de Nemours, Zytel ST-801

Polyester - E.I. duPont de Nemours, Hytrel 7246

PVC compound - Firestone, FPC 1442-143

- B.F. Goodrich Co., Geon 8700A

Other compounds which have favorable properties but which have yet to be screen tested are:

ABS alloys such as - Commercial Plastics Co., ABS polycarbonate alloy

- Borg-Warner, Cyclolac

Isocyanated based resins - Upjohn CPR Division, Isoplast

Nylon 6/6 - E.I. duPont de Nemours, Zytel ST900

Nylon 11 and 12 - Rilsan Corporation, Rilsan

Polycarbonate modified - General Electric, Xenoy; Elastomer modified

- Mobay, polyester modified

Polyphenylene oxide modified - General Electric, Noryl

Polyvinyl chloride (PVC) modified - Occidental Chemical, Oxytuf; Graft

co-polymer with vinyl; EPDM

- B.F. Goodrich Co., Geon

The thermoplastic industry is very dynamic and new materials appear in the market every year. Some may exhibit characteristics superior to those of the promising materials above mentioned. Readers interested in this fast evolving field should remain alert and cognizant of the new products and techniques as they become available.

5.2.3.6. Procedures for testing fishbite armors at sea.

Site selection. The test site must be in a location where biting probability is high. A good fishbite testing site should be well within the Fishbite Zone, close to the equator or at least within 30 degrees north or south of the equator. A bottom depth greater than 2000 meters is desirable.

Test mooring. Special moorings may be established for fishbite testing or test lines may be incorporated into mooring lines whose primary function is something else. The latter method is attractive from a cost standpoint but has the disadvantage that fishbite research must wait upon someone else's good will and timetable.

Two approaches can be followed to design fishbite test moorings. Ideally moorings with only one candidate armor could be deployed at the same site and their performance established over the same time interval. This approach is costly and should be reserved for the final stage of a rigorous evaluation program, for example to assess the endurance of the two best candidate armors.

The second approach is to simply insert a number of different armor specimen at regular intervals along the mooring line. Groups of samples can be inserted in series or mounted in parallel on fishbite resistant racks or frames. At present it is not known if such frames have been successfully

used. There are some indications that some biters, especially sharks, are shy about approaching large objects. In any case the placement of this group of samples as a function of depth is critical and should be selected to not only increase the probability of biting but also to cover the entire range of fishbiting activity, say down to at least 1500 meters.

When the samples are in series, due concern must be given to the integrity of the mooring. Alternatively, means of recovering a severed mooring from the bottom up could be incorporated in the mooring design (Berteaux and Heinmiller, 1973).

Test duration. The time needed to get a satisfactory fishbite attack varies from one location to another. As previously mentioned, the average expectancy for the Fishbite Zone as a whole is 25% of lines bitten in 400 days. Near the equator however, results can be obtained much faster. A good test mooring could be designed for a maximum exposure of 18 months with recovery, inspection, removal of some samples, and resetting at regular six month intervals.

Armor specimen preparation. Properties and resistance to stab and cut of the jacket and armor specimen should be obtained prior to their deployment at sea. They should again be measured after recovery. Lengths of wire ropes covered with soft jacket material (polyurethane, polyethylene) should be placed in every group of specimens under test for bite monitoring and damage comparison purposes. It is prudent, particularly when placed in series, to keep the core of the specimen immune to fishbites. Use of wire rope is again indicated.

Analysis of recovered specimens. Specimens recovered from a fishbite test mooring should be examined as recommended in Chapter 2. If the test has been a good one, the soft jacketed control samples should be liberally

bitten with armor pierced or stripped to the underlying wire rope. Broken teeth would be found here and there. Under the same circumstances a well armored line should have no structural damage and the armor should have only superficial tooth marks.

APPENDIX A

CONVERSION OF UNITS: METRIC TO U.S.

<u>LENGTH</u>	<u>Millimeters</u>	<u>Inches</u>	<u>Mils</u>
	1.0	0.039	39
	3.2	1/8	125
	6.4	1/4	250
	12.7	1/2	500
	25.4	1	1000

<u>Meters</u>	<u>Feet</u>
1	3.28
100	328
500	1640
1000	3281
2000	6562
3000	9843
4000	13123
5000	16404

FORCE 4.45 newtons = 1 pound

<u>TEMPERTURE</u>	<u>Celcius</u>	<u>Fahrenheit</u>
	-40	-40
	-18	0
	0	32
	49	120
	100	212

REFERENCES

- Anonymous. 1968. A fish (?) story. NOL gets lots of bites on its lines. The Oak Leaf 25(5).
- Associated Press. 1970. Australian invents a device said to keep sharks at bay. New York Times, 26 Jul.
- Backus, R.H. 1984. Private communication with author. Woods Hole Oceanogr. Inst., Woods Hole, MA.
- Backus, R.H., S. Springer and E.L. Arnold. 1956. A contribution to the natural history of the White tip shark, Pterolamiops longimanus (Poey). Deep Sea Research 3: 178-188.
- Banchero, L.A. 1966. Mooring cable attacked by sharks. Geo-Marine Technology 3(1): 5-6.
- Barkas, W.D., E.D. van Rest and W.E. Wilson. 1932. The principles of wood working. H.M. Stationary Office, London.
- Berteaux, H.O. 1969. Analysis and experimental evaluation of single point moored buoy systems. Woods Hole Oceanogr. Inst. Tech. Rept. WHOI-69-36.
- Berteaux, H.O. and R. Heinmiller. 1973. Back up recovery systems of deep-sea moorings. Marine Technology Society Journal 7(3).
- Bigelow, H.B. and W.C. Schroeder. 1948. Sharks. Memoirs of the Sears Foundation for Marine Research. Fishes of the North Atlantic 1(1): 59-546.
- Bonde, C.E. 1979. Biology of fishes. Saunders College Publ., Philadelphia, PA.
- Boy, R.L. and B.R. Smith. 1984. Design improvements to Fish Aggregation Device (FAD) mooring systems in general use in Pacific Island countries. South Pacific Commission Handbook No. 24.
- Bradbury, G.S. 1976. Private communication with author. General Electric Co., Philadelphia, PA.
- Brown, C.L. 1966. Private communication with author. NUSC, OTD, Newport, RI.
- Carr, A. 1952. Handbook of turtles. Cornell University Press, Ithica, NY.
- Castelliz, H. 1974. Private communication with author. Hermes Electronics, Ltd., Dartmouth, NS.
- Clark, E. 1986. Sharks at 2000 feet. National Geographic Magazine 170(5): 681-691.

- Cornillon, P. 1986. The effect of the New England seamounts on Gulf Stream meandering as observed from satellite IR imagery. Journal of Physical Oceanography 16(2): 386-389.
- Cousteau, J.I. and P. Cousteau. 1970. The shark. Doubleday & Co., Garden City, NY.
- Deuser, W.G. 1986. Private communication with author. Woods Hole Oceanogr. Inst., Woods Hole, MA.
- Ditmars, R.L. 1933. Reptiles of the world. The MacMillan Co., New York, NY.
- Fuglister, F.C. 1960. Atlantic atlas of temperature and salinity profiles and data. WHOI Atlas Series Vol. 1. Woods Hole Oceanogr. Inst., Woods Hole, MA.
- Gilbert, P.W., R.F. Mathewson and D.P. Hall. 1967. Sharks, skates, and rays. The Johns Hopkins Press, Baltimore, MD.
- Gilbert, P.W., A. Beulig, R. Legatti and P. Steiner. 1971. Reactions of sharks known to be dangerous to man, to the shark shield. Mote Marine Laboratory report to Electromagnetic Industries, Inc.
- Giuliano, D.F. 1968. Fishbite occurrence on a deep sea mooring cable. USL Tech. Memo. No. 2213-259-68.
- Goode, G.B. and T.H. Bean. 1895. Oceanic ichthyology. Government Printing Office, Washington, DC.
- Gray, S. and C.S. Johnson. 1979. Solution to AN/BQR-19 hydrophone boot problem. NOSC, OSD, San Diego, CA.
- Haedrich, R.L. 1965. Identification of a deep sea mooring cable biter. Deep Sea Research 12: 773-776.
- Hartman, P.L. 1972. Examination of mooring line samples containing fishbites. NDBC, MSD, Rept. No. WBS6221.
- Hodgson, E.S. and R.F. Mathewson. 1978. Sensory biology of sharks, skates, and rays. ONR, Arlington, VA.
- Isaacs, J.D. 1969. The nature of oceanic life. Scientific American 221(3): 146-162.
- LeGall, J.Y. 1972. Cisaillement d'une ligne de Mouillage profond par un Poisson Sabre: Aphanopus carbo (Poisson Trichiuridae). Bulletin de la Societe Scientifique de Bretagne 47: 25-31.
- Levine, J.S. and E.F. MacNichol, Jr. 1982. Color vision in fishes. Scientific American 246(2): 140-149, 170.
- Madelain, D.F. 1971. Rapport de mission PHYGIB (CNEXO-COB) du 24/9 au 10/11/1971. Doc. Int. CNEXO-COB GS/71-34/FM, 1971.

- Marra, D.E. 1974. Private communication with author. Clinton, MD.
- Marshall, N.B. 1971. Exploration in the life of fishes. Harvard Univ. Press, Cambridge, MA.
- Modern Plastics Encyclopedia. Yearly edition. Modern Plastics, Hightstown, NJ.
- Morey, R. and H.O. Berteaux. 1973. Alleviation of corrosion problems in deep-sea moorings. Proceedings of the Third International Congress of Marine Corrosion and Fouling. Northwestern Univ., IL.
- Mosey, R.M. 1975. Private communication with author. St. Croix, VI.
- Nelson, J.S. 1983. Fishes of the world. Wiley & Sons, Inc., New York, NY.
- O'Brien, T.F. 1981. Fishbites on towed acoustical array. Oceanus Magazine 99: 8.
- O'Malley, P. 1976. Private communication with author. Woods Hole Oceanogr. Inst., Woods Hole, MA.
- Pope, C.H. 1939. Turtles of the United States and Canada. Alfred A. Knopf, New York, NY.
- Prindle, B. 1977. Improved fishbite armor for deep sea mooring lines. Woods Hole Oceanogr. Inst. Tech. Rept. WHOI-77-54.
- Prindle, B. 1980. Fishbite analysis of National Data Buoy Center mooring 42001 10D9. Woods Hole Oceanogr. Inst., Woods Hole, MA.
- Prindle, B. 1983. Report of fishbite analysis on National Data Buoy Center No. CC;83 06608 (6N02) mooring. Woods Hole Oceanogr. Inst., Woods Hole, MA.
- Prindle, B. 1983. Report of fishbite analysis on ST REX drifter buoys. Woods Hole Oceanogr. Inst., Woods Hole, MA.
- Prindle, B. 1985. Report on fishbite analysis of Westinghouse Buoy No. 3. Westinghouse Oceanic Div., Annapolis, MD.
- Prindle, B. and R.G. Walden. 1975. Deep-sea lines fishbite manual. NDBC, NOAA, Bay St. Louis, MS.
- Sagstad, G. 1983. Private communication with author. Aanderaa Instruments, Norway.
- Schick, G.B. and P.M. Marshall. 1966. Jacketed deep sea mooring line. Geo-Technology 2(8): V294-V297.
- Schultz, L.P., P.W. Gilbert and S. Springer. 1964. Shark attacks. Science 134: 87-88.

- Sessions, M.H. and D.M. Brown. 1969. Design of deep-moored instrument stations. Scripps Institution of Oceanography, La Jolla, CA.
- Skipp, P.B. 1974. Private communication with author. Univ. of Miami, FL.
- Smith, E.D. 1966. Electrical shark barrier research. Geo-Marine Technology 2(10): 10-14.
- Stimson, P.B. 1964. Synthetic fiber deep-sea mooring cables: Their life expectancy and susceptibility to biological attack. Deep Sea Research 12: 1-8.
- Stimson, P.B. 1964. Performance record of moored buoy stations. Woods Hole Oceanogr. Inst. Tech. Rept. WHOI-64-14.
- Stimson, P.B. and B. Prindle. 1972. Armoring of deep-sea mooring lines against fishbite. Woods Hole Oceanogr. Inst. Tech. Rept. WHOI-72-75.
- Turner, H.J. and B. Prindle. 1965. Some characteristics of 'fishbite' damage on deep-sea mooring lines. Limnology and Oceanography 10: R259-R264.
- Turner, H.J. and B. Prindle. 1968. The vertical distribution of fishbites on deep-sea mooring lines in the vicinity of Bermuda. Deep Sea Research 15: 377-379.
- Turner, R.D. 1969. Private communication with author. MCZ, Harvard Univ., Cambridge, MA.
- U.S. Naval Oceanographic Office. 1969. The Gulf Stream. NOO, Washington, DC.
- Wiebe, P. 1978. Gulf Stream rings. Woods Hole Notes 10(4): 1-4.
- Willis, P.R. 1985. Shark attack on an instrument case in the Indian Ocean. Private communication with author. Salem, MA.
- Zahn, G.A. 1974. Deep sea ventures. Private communication with author. Gloucester Point, VA.

DOCUMENT LIBRARY

November 21, 1986

Distribution List for Technical Report Exchange

Institute of Marine Sciences Library
University of Alaska
O'Neill Building
905 Koyukuk Ave., North
Fairbanks, AK

Attn: Stella Sanchez-Wade
Documents Section
Scripps Institution of Oceanography
Library, Mail Code C-075C
La Jolla, CA 92093

Hancock Library of Biology & Oceanography
Alan Hancock Laboratory
University of Southern California
University Park
Los Angeles, CA 90089-0371

Gifts & Exchanges
Library
Bedford Institute of Oceanography
P.O. Box 1006
Dartmouth, NS, B2Y 4A2, CANADA

Office of the International
Ice Patrol
c/o Coast Guard R & D Center
Avery Point
Groton, CT 06340

Library
Physical Oceanographic Laboratory
Nova University
8000 N. Ocean Drive
Dania, FL 33304

NOAA/EDIS Miami Library Center
4301 Rickenbacker Causeway
Miami, FL 33149

Library
Skidaway Institute of Oceanography
P.O. Box 13687
Savannah, GA 31416

Institute of Geophysics
University of Hawaii
Library Room 252
2525 Correa Road
Honolulu, HI 96822

Library
Chesapeake Bay Institute
4800 Atwell Road
Shady Side, MD 20876

MIT Libraries
Serial Journal Room 14E-210
Cambridge, MA 02139

Director, Ralph M. Parsons Laboratory
Room 48-311
MIT
Cambridge, MA 02139

Marine Resources Information Center
Bldg. E38-320
MIT
Cambridge, MA 02139

Library
Lamont-Doherty Geological Observatory
Columbia University
Palisades, NY 10964

Library
Serials Department
Oregon State University
Corvallis, OR 97331

Pell Marine Science Library
University of Rhode Island
Narragansett Bay Campus
Narragansett, RI 02882

Working Collection
Texas A&M University
Dept. of Oceanography
College Station, TX 77843

Library
Virginia Institute of Marine Science
Gloucester Point, VA 23062

Fisheries-Oceanography Library
151 Oceanography Teaching Bldg.
University of Washington
Seattle, WA 98195

Library
R.S.M.A.S.
University of Miami
4600 Rickenbacker Causeway
Miami, FL 33149

Maury Oceanographic Library
Naval Oceanographic Office
Bay St. Louis
NSTL, MS 39522-5001
ATTN: Code 4601

REPORT DOCUMENTATION PAGE	1. REPORT NO. WHOI-87-8	2.	3. Recipient's Accession No.
4. Title and Subtitle Deep Sea Moorings Fishbite Handbook		5. Report Date March 1987	
7. Author(s) H.O. Berteaux and Bryce Prindle		6.	
9. Performing Organization Name and Address Woods Hole Oceanographic Institution Woods Hole, Massachusetts 02543		8. Performing Organization Rept. No. WHOI-87-8	
12. Sponsoring Organization Name and Address Office of Naval Research Environmental Sciences Directorate Arlington, VA 22217		10. Project/Task/Work Unit No.	
15. Supplementary Notes This report should be cited as: Woods Hole Oceanog. Inst. Tech. Rept., WHOI-87-8.		11. Contract(C) or Grant(G) No. (C) N00014-84-C-0134, (G) NR 083-400	
16. Abstract (Limit: 200 words) The purpose of this handbook is to bring awareness and a degree of expertise to the problem of fish attacks on mooring lines and cables deployed in the open seas. A short introduction retraces the early suspicions which soon translated into confirmed fish attacks. The next two chapters cover the recognition and the extent of the fishbite problem. Chapter 2 presents the techniques which can be used to determine how a rope was damaged while in service. The analysis of a data base which spans over twenty years and encompasses close to a thousand moorings is presented in Chapter 3 with valuable information for use in estimating fishbite hazard. Chapter 4 identifies the marine organisms which have significant biting capabilities and outlines some of the environmental factors and processes which incite and result in fishbite damage. The last chapter reviews the preventive methods used to reduce the incidence or the severity of fish attacks and the curative methods--including up-to-date techniques for jacketing metallic and non-metallic ropes and cables--which hopefully will protect mooring lines from the mechanical damage inflicted by fish teeth.		13. Type of Report & Period Covered Technical	
17. Document Analysis a. Descriptors 1. Fishbite 2. Fish attack 3. Mooring lines b. Identifiers/Open-Ended Terms c. COSATI Field/Group		14.	
18. Availability Statement: Approved for publication; distribution unlimited.	19. Security Class (This Report) UNCLASSIFIED	21. No. of Pages 180	
	20. Security Class (This Page)	22. Price	

WHOI-87-8

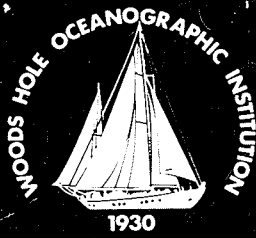

Woods Hole Oceanographic Institution

DEEP SEA MOORINGS FISHBITE HANDBOOK



March 1987

Henri O. Berteaux

Dr. Bryce Prindle