

GC
7.1
M79
1973

ASPECTS OF THE BIOGEOCHEMISTRY
OF CARBOHYDRATES IN
AQUATIC ENVIRONMENTS

by

KENNETH MOPPER

B.S., Queens College, New York
(1968)

M.S., Massachusetts Institute of Technology
(1971)

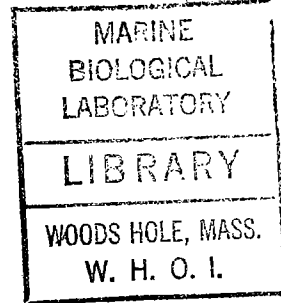

SUBMITTED IN PARTIAL FULFILLMENT OF THE
REQUIREMENTS FOR THE DEGREE OF
DOCTOR OF PHILOSOPHY

at the

MASSACHUSETTS INSTITUTE OF TECHNOLOGY

and the

WOODS HOLE OCEANOGRAPHIC INSTITUTION

June, 1973

Signature of Author *Kenneth Mopper*
Joint Program in Oceanography, Massachusetts Institute of
Technology - Woods Hole Oceanographic Institution, and
Department of Earth and Planetary Sciences, and Department
of Meteorology, Massachusetts Institute of Technology,
June, 1973

Certified by *Egon T. Degens*
Thesis Supervisor

Accepted by *James D. Brown*
Chairman, Joint Oceanography Committee in the Earth
Sciences, Massachusetts Institute of Technology - Woods
Hole Oceanographic Institution

ABSTRACT

Aspects of the Biogeochemistry of Carbohydrates
in Aquatic Environments

Kenneth Mopper

LIB
2155
Submitted to the Department of Earth and Planetary Sciences in June, 1973,
in partial fulfillment of the requirements for the degree of Doctor of
Philosophy.

The goal of this thesis is to examine the distribution and diagenesis of carbohydrates in aquatic environments. The following questions are studied: what is the carbohydrate composition of sediment in different environments (e.g., deep-sea oxic; shallow-sea oxic; deep-sea anoxic; fresh-water anoxic; brackish-water anoxic, etc.)? How does the environment at the sediment-water interface affect the composition of the carbohydrate input? How do sedimentary carbohydrates compare to plankton carbohydrates? How do metal-carbohydrate interactions and biological degradation affect the diagenesis of carbohydrates in recent sediments? Can fossil carbohydrates be used as a means to elucidate paleo-environments?

In order to investigate these questions in a quantitative manner, a liquid chromatographic sugar analyzer sensitive to 10^{-10} moles was constructed. Various extraction techniques, involving acid hydrolysis and EDTA treatment, were thoroughly examined to determine lability of sugars, sources of contamination, maximum yields, and reproducibility. Furthermore, several experiments were performed to show that sugars extracted from sediment by EDTA were originally associated with in situ metal ion organic complexes.

1977-00401
Although the carbohydrate compositions of sediment from different aquatic environments are remarkably similar, the degree of metal binding of carbohydrates varies between oxidizing and reducing sediments and appears to be related to the degree of biological degradation at the sediment-water interface. In an oxic environment, biological degradation produces a highly metal-bound carbohydrate residue. In a reducing environment, the degree of biological activity is low (relative to oxic environments) and hence the degree of metal binding of the resulting carbohydrate residue is low. There is no evidence for further abiotic alteration after burial in

either environment.

Sewage material dumped into a shallow oxic environment is degraded rapidly despite the high content of potentially toxic metals; these metals are probably tied-up in the metal bound carbohydrate residue.

Metal binding appears to fix potentially soluble carbohydrates in situ, thereby inhibiting diffusion. This finding undercuts the previous belief that chromatographic separation of organic molecules along mineral surfaces is a significant diagenetic process.

The relative abundances of sugars in acid extracts of sediment and plankton from different aquatic environments are similar; this similarity suggests that plankton is the main source of sedimentary carbohydrates.

Carbohydrates in sediment may be used to interpret paleo-environmental fluctuations. For example, the degree of metal binding is indicative of the Eh at the sediment-water interface. The glucose and ribose contents of sediment may be used to estimate relative terrigenous and marine organic inputs, respectively. Paleo-eutrophication conditions in the surface waters also may be discerned.

Thesis Supervisor, Egon T. Degens

Title: Senior Scientist, Department
of Chemistry, Woods Hole
Oceanographic Institution,
Woods Hole, Massachusetts

ACKNOWLEDGEMENTS

I wish to express my warmest and deepest appreciation to Egon T. Degens, whose invaluable advice and criticism and unwavering guidance has made this research effort both enjoyable and enlightening.

Stimulating discussions of the data with John M. Hunt, Holger W. Jannasch, K. O. Emery, and Anne Boersma were greatly helpful.

Critical reviews of the preliminary manuscript by Paul Mangelsdorf, George Harvey, Robert Gagorian, Max Blumer, and John Edmond are also appreciated.

I also wish to acknowledge the helpful advice of H. Burr Steinbach and A. Lawrence Peirson of the Education Department at the Woods Hole Oceanographic Institution.

The typing assistance of Gay Mosier and Christine Johnson is also appreciated.

Drafting of the illustrations was carefully conducted by Dorothy Meinert.

The research was sponsored by a grant from the Petroleum Research Fund PRF-1943A, administered by the American Chemical Society, by grants from the National Science Foundation 20-25234 and 20-30641, and by a grant from the Woods Hole Oceanographic Institution Education Office ED-1100.

BIOGRAPHICAL NOTE

I received a B.A. in chemistry from Queens College (N. Y.) in 1968. During my junior and senior years I participated in a research program at the Lamont-Doherty Geological Observatory, where I worked with Dr. G. D. Garlick on problems pertaining to oxygen isotope fractionation in biogenic silica.

Between 1968 and 1969 I attended the M.I.T. Graduate School, Department of Earth and Planetary Sciences. During the fall semester I instructed the laboratory for the undergraduate mineralogy course. At the end of the first year I transferred to the joint program in oceanography between M.I.T. and the Woods Hole Oceanographic Institution. Based on research conducted at W.H.O.I., I received a M.S. degree from M.I.T. in 1971; the thesis title is "A new micro-analytical system for reducing sugars — applications to sediment and seawater".

My contributions to the literature are:

- i) Mopper K. and Garlick G. D. (1971) Oxygen isotope fractionation between biogenic silica and ocean water. *Geochim. Cosmochim. Acta* 35, 1185-1187.
- ii) Mopper K. (1971) Some considerations of the effects of natural and man-made anoxic conditions on the environment. In Papers on National Land Use Policy Issues, Committee on Interior and Insular Affairs (chairman H. M. Jackson), Senate, 92nd Congress.

- iii) Harvey G. R., Degens E. T., and Mopper K. (1971) Synthesis of nitrogen heterocycles on kaolinite from CO₂ and NH₃. *Naturwissenschaften* 12, 624-625.
- iv) Mopper K. and Degens E. T. (1972) A new chromatographic sugar auto-analyzer with a sensitivity of 10⁻¹⁰ moles. *Anal. Biochem.* 45, 147-153.
- v) Harvey G. R., Mopper K., and Degens E. T. (1972) Synthesis of carbohydrates and lipids on kaolinite. *Chem. Geol.* 9, 79-87.
- vi) Mopper K. and Degens E. T. (1972) Aspects of the biogeochemistry of carbohydrates and proteins in aquatic environments. *Techn. Rep. Woods Hole Oceanogr. Inst. Ref. No. 72-68.*
- vii) Hecky R. E., Mopper K., Kilham P. and Degens E. T. (1973) The amino acid and sugar composition of diatom cell walls. *Mar. Biol.* 18, in press.
- viii) Mopper K. and Degens E. T. (1974) Distribution and diagenesis of amino acids and sugars in sediments. *Geochim. Cosmochim. Acta*, submitted for publication.
- ix) Degens E. T. and Mopper K. (1974) Factors controlling the distribution and early diagenesis of organic material in marine sediments. In *Chemical Oceanography* (editors R. Chester and J. P. Riley), in press.

TABLE OF CONTENTS

	Page
INTRODUCTION	15
CHAPTER I	17
1. HISTORICAL REVIEW OF CARBOHYDRATE GEOCHEMISTRY	17
2. GOALS OF THE RESEARCH	33
CHAPTER II: ANALYTICAL PROCEDURES	34
1. AUTOMATIC SUGAR CHROMATOGRAPHY	34
a. Type of Eluent	40
b. Eluent Flow Rate	40
c. Resins	40
d. Dimensions of Resin Bed	41
e. Column Temperature	41
f. Dye Reagent	41
2. APPLICATION OF SUGAR ANALYZER TO SEDIMENT	43
a. Clean-up Procedure	43
b. Co-chromatography	43
c. Absolute Identification of Sugars by Gas Chromatography-Mass Spectrometry	45
3. EXTRACTION OF CARBOHYDRATES FROM SEDIMENT: ACID HYDROLYSIS	49
a. Sample Drying Procedure	50
b. HF Pretreatment	52
c. Acid Hydrolyses	54
d. Deionization Techniques	62
e. Volume Reduction	63
4. EXTRACTION OF CARBOHYDRATES FROM SEDIMENT: EDTA TREATMENT	64
a. Optimal Time of Extraction	64
b. Temperature Effects	68

c. Stability of Sugars in EDTA Solution	68
d. Hydrolysis Effects	70
e. pH and CaCO ₃ Effects	72
5. GENERAL SAMPLE WORK-UP	75
CHAPTER III: SIGNIFICANCE OF THE EDTA EXTRACTS AND CARBOHYDRATE-METAL ION INTERACTIONS IN SEDIMENT AND SOIL	77
1. SOIL SCIENCE LITERATURE	77
2. METAL-CARBOHYDRATE COMPLEXES	86
3. CHEMISTRY OF EDTA	90
4. EXTRACTION OF METAL-BOUND CARBOHYDRATES FROM SEDIMENT	94
CHAPTER IV: PRESENTATION AND DISCUSSION OF DATA	98
1. PRESENTATION OF DATA	98
2. DISCUSSION OF SAMPLE TYPES	99
a. Plankton	99
b. Organic Waste Products	101
c. New York Bight and Hudson Canyon	105
d. Argentine Basin	107
e. Cariaco Trench	113
f. Santa Barbara Basin	118
g. Walvis Bay	119
h. Black Sea	120
i. Oyster Pond	125
j. Lake Kivu	126
CHAPTER V	128
1. DISCUSSION OF GENERAL TRENDS	128
2. PALEOENVIRONMENTAL CRITERIA	147
CHAPTER VI: SUMMARY AND CONCLUSIONS.	148
REFERENCES	154

APPENDIX I: DISCUSSION OF SAMPLE MATERIAL	164
a. Plankton	165
b. Organic Waste Products	166
c. Argentine Basin	167
d. New York Bight and Hudson Canyon	170
e. Cariaco Trench	172
f. Santa Barbara Basin	174
g. Walvis Bay	174
h. Black Sea	175
i. Oyster Pond	177
j. Lake Kivu	178
k. C/N Ratios of Various Sediments	179
APPENDIX II: BACKGROUND DATA	182
APPENDIX III: DATA FILE OF CARBOHYDRATE ANALYSES	187
APPENDIX IV: GLOSSARY	216

LIST OF FIGURES

Figure		Page
1	Schematic of automatic sugar analyzer	36
2	Chromatogram of a standard sugar solution	38
3	Quantification of sugar analyzer by peak area	39
4	Intercalibration between two laboratories of sugar analytical techniques	46-47
5	Intercalibration study continued	48
6	Tests of extraction techniques with standards	51
7	Determination of hydrolysis efficiencies of various acids	53
8	Determination of hydrolysis time and acid concentration parameters for the hydrolysis of a sediment with H_2SO_4	55
9	Determination of hydrolysis time and acid concentration parameters for the hydrolysis of a sediment with HCl	56
10	Comparison of hydrolysis efficiencies of 1.85 M and 0.35 M H_2SO_4 for a sediment	59
11	Comparison of the hydrolyzed EDTA extract and the total acid extract of a sediment	65
12	Determination of optimal time of EDTA, and H_2O extractions of a sediment	67
13	Determination of optimal temperature of EDTA, and H_2O extractions of a sediment	69
14	Schematic of carbohydrate extraction techniques	76
15	Coordination complex of EDTA and Mn^{+2}	91

Figure		Page
16	Coordination polyhedron: AB_7 of the $Mn(EDTA)^{-2}$ complex	93
17	Ribose and glucose fluctuations in Argentine Basin sediments	108
18	Depth changes in carbohydrate carbon relative to total organic carbon in Lake Kivu, Cariaco Trench, and Argentine Basin sediments	110
19	Comparison of the temporal changes in the degree of metal binding of carbohydrates in Cariaco Trench and Argentine Basin sediments	112
20	Relationship between the total organic carbon and total sugars in Cariaco Trench sediments	114
21	Ribose and glucose fluctuations in Cariaco Trench sediments	115
22	Electron micrographs of organic matter in a Black Sea sediment	123-124
23	Relationship between glucose and ribose in samples analyzed	131
24	Relationship between sediment carbohydrate extracts and plankton	135
25	Relationship between EDTA extractable monomers and polymers in different sediment samples	138
26	Comparison of the degree of metal binding of carbohydrates from various sedimentary environments	139
27	Relationship between sugar carbon and hydrolyzed EDTA extracts of samples studied	142
28	Relationship between C-N ratios and hydrolyzed EDTA extracts of various samples	145
29	Hypothetical schematic of the biogeochemical cycle in the ocean	149

Figure

Page

30	A highly hypothetical schematic of the carbohydrate residue of sediment	153
----	--------------------------------------------------------------------------------------	-----

Appendix I:

I-1	Fluctuations of organic carbon in cores from the Black Sea, Lake Kivu, and Argentine Basin	168
I-2	Seasonal positions of the subtropical convergence in the Argentine Basin	171
I-3	C-N ratios in cores from areas studied	180

LIST OF TABLES

Table		Page
1	Spiking of Argentine Basin sediment with a standard sugar solution	44
2	Extraction of carbohydrates by acid hydrolysis of aliquots of a Black Sea sediment core	57
3	Spiking of Argentine Basin sediment with CaCO_3	61
4	Effects of EDTA and Chelex 100 on sugar standards	71
5	pH values of EDTA extracts of sediment	73
6	Log of the equilibrium constants of metal-soil organic matter complexes	82
7	Log of the equilibrium constants of metal chelator complexes	83
8	Comparison of major oxygen-containing functional groups and elemental compositions of organic extracts of soils and sediments	87
9	Chelex experiment	96
10	Metal analyses of nitric acid digested, and EDTA extracted sewage sludges	104
11	Comparison of the carbohydrate composition of true land-derived marine sediment and possible land-derived sediment	122
12	Summary of mole % composition of carbohydrates in sediment and plankton: HCl hydrolysis	129
13	Summary of mole % composition of carbohydrates in sediment: hydrolyzed EDTA extract	132
14	Summary of mole % composition of carbohydrates in sediment: unhydrolyzed EDTA extract	133

Table

Page

III-1-17 Data file of carbohydrate analyses in Appendix III . . . 188-215

INTRODUCTION

The bulk of organic carbon in the crust of the Earth is present in sedimentary rocks as a highly dispersed inert material called kerogen¹ (e.g., Breger and Brown, 1962). Since most of this carbon has been cycled through the biosphere, biomolecules such as carbohydrates¹ are the starting materials from which kerogen is formed.

During early diagenesis in sediment, decay and metabolic degradation of these biomolecules results in randomization of the original well-defined structural order of living matter. The various organic molecules present in sediment may not only interact among themselves but may also interact with metal ions and mineral surfaces. As a result, the complexity of reaction schemes and resultant organic products becomes immense.

Dayhoff et al. (1964) demonstrated that biomolecules are far removed from thermodynamic equilibrium. Therefore, diagenesis of organic matter in sediment is expected to proceed in a direction of increasing thermodynamic stability; i.e.:

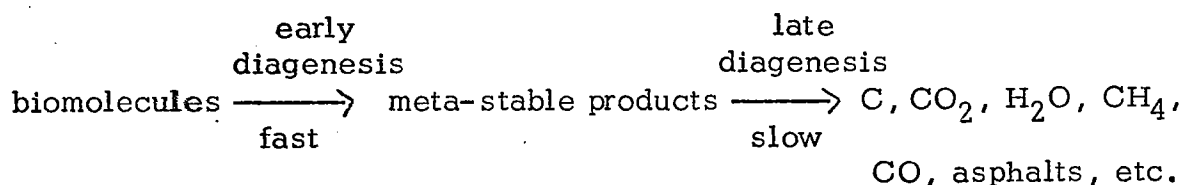

The approach to thermodynamic stability, however, is extremely slow and for most organic matter it is never reached (Blumer, 1967). The

¹ See glossary, Appendix IV.

transformation of biomolecules appears to be kinetically inhibited by the formation of meta-stable associations during the early stages of diagenesis. In fact, fragile biomolecules such as carbohydrates (Swain, 1969) and amino acids (Hare, 1969) have been extracted from rocks of Paleozoic and Precambrian ages. The usefulness of organic geochemistry for understanding the origin of kerogen² and humus² and for discerning paleoenvironments has been limited by a lack of knowledge of the factors affecting the transformation of biomolecules during early diagenesis.

The advent of sophisticated instrumentation (i.e., high resolution gas chromatography-mass spectroscopy) has facilitated the compilation of an inventory of molecular species present in sediment (Simoneit and Burlingame, 1972).

The object of the present thesis research has been to elucidate some of the processes affecting the diagenesis of organic matter in recent sediments from different depositional environments. Insights into these processes can be gained by the detailed study even of only a few organic compounds.

I have chosen to investigate the problems of diagenesis in terms of in situ variations of carbohydrates. Carbohydrates represent a large fraction of the organic matter of many organisms (e.g., zooplankton - 5%, diatoms - 30%, phytoplankton - 60%). Therefore, a significant fraction of the organic input of sediments is carbohydrates.

²See glossary, Appendix IV.

CHAPTER I

1. HISTORICAL REVIEW OF CARBOHYDRATE GEOCHEMISTRY

Waksman (1933) proposed that sedimentary marine humus consists of two major fractions. One fraction is allochthonous (foreign origin) and is composed of land-derived lignin³-protein complexes, which are of similar nature to terrigenous field soil humus. The other fraction is autochthonous (indigenous) and consists of carbohydrate-protein complexes. The source of the second fraction was postulated to be marine algae. The relative abundance of these fractions was found to vary from location to location with the former being more important close to shore. A short distance from shore (~1 km), however, the autochthonous fraction dominated. Although the actual composition of the carbohydrates within the extracted humus was not determined by Waksman (1933), I suggest in a later section that the carbohydrate compositions of various sediments also reflect terrigenous and marine (algal) sources. The relative proportion of the terrigenous and marine carbohydrate fractions is reflected in the relative proportion of acid-extracted glucose and ribose (e.g., p. 107).

ZoBell and Grant (1943) showed that fresh water and marine microorganisms are capable of utilizing even the slightest traces of sugars (and other organics) from dilute nutrient solutions. Therefore, it was proposed that the concentration of free sugars in natural environments would be

³ See glossary, Appendix IV.

extremely low. This belief has been tested by Vallentyne and Bidwell (1956) who established a semi-quantitative method for the extraction and identification of free sugars in lake muds.

Their sediments, dredged from various Connecticut lakes, were extracted several times with water and 70% aqueous ethanol. The combined extracts were deionized with strong cation and anion exchange resins. Losses up to 50% occurred when ribose and xylose⁴ standards were passed through the resins; other sugars were unaffected. (The sediment results were not corrected for these losses.) I encountered similar destructive effects when I tested various ion exchange resins (e.g., p. 62). I found that the high basicity of the anion resin was mainly responsible for this destruction. Converting the anion resin from the hydroxide form to either the formate or bicarbonate form eliminates this problem.

Vallentyne and Bidwell (1956) separated and estimated sugars by means of paper chromatography; identification of sugars was achieved by co-chromatography with sugar standards. A few of the extracts were hydrolyzed in 3N HCl at 100°C for five minutes prior to deionization; the sediment residues were hydrolyzed in 0.25N HCl at 100°C for one hour. The authors claimed an accuracy of 20%, however, the reproducibility of the extractions were not determined. The following sugars were identified: sucrose, glucose, galactose, fructose, arabinose, xylose, and ribose⁴. Glucose was the most abundant free sugar and was present in concentrations of 100 to 250 mg per kg sediment ignitable matter. The ignition

⁴See glossary, Appendix IV

procedure was not described, therefore, it can only be assumed that the ignitable matter represents the total organic matter.

The authors speculated that the source of the free sugars is either from free sugars of higher plants (terrigenous) or from the in situ breakdown of polysaccharides of algae and higher plants. They also proposed that if free sugars are unstable in the sedimentary environment (e.g., a half-life ranging from a few hours to a few weeks), their presence in sediment suggests a steady-state condition in which the input rate of sugars derived from plankton and in situ polysaccharide hydrolysis is balanced by the rate of microbial decomposition. If free sugars are stable in sediment (e.g., half-life of five years or more), then the authors proposed that they may be present in meta-stable sugar-mud associations which are inaccessible to microbial or free-enzyme degradation. In a later section I argue that incorporation of sugars into metal ion-organic complexes enhances their stability in sediment (e.g., pp. 150-151).

Whittaker and Vallentyne (1957) also conducted a study of free sugars in lake muds (Ontario lakes). The analytical techniques employed were similar to those of Vallentyne and Bidwell (1956). Similar losses on ion exchange resins were reported. The sugars detected were: maltose, sucrose, glucose, fructose, galactose, arabinose, ribose, xylose, and two unknowns. Maltose and glucose were dominant. The total quantity of free sugars detected ranged from traces up to 2.9 g/kg of sediment ignitable matter (the ignitable matter was 40 to 50% of the sediment on a dry weight

basis; the ignition technique was not described).

Analyses of cores revealed that the concentration of free sugars decreased by two orders of magnitude between the surface and 20 cm; the % ignitable matter only decreased slightly in this interval (~ 20% decrease), which suggested that sugars are gradually eliminated until a small amount is left below 20 cm; in the interval of 0 to 20 cm a balance exists between the supply and decomposition of sugars. The authors estimated the decomposition period to be on the order of 20-120 years.

The authors presented evidence to show that tendipedid larvae (two-winged flies) and living bacteria are negligible sources for sedimentary free sugars. They considered seston (dominantly algae) to be the main source; the seston samples examined contained 2.3 to 42.2 g sugar per kg dry weight, with glucose and maltose dominant. They speculated that seston could contribute free sugars either directly or indirectly by in situ hydrolysis of polysaccharides. Hydrolysis could be achieved through autolytic enzymes within the plankton cells, through microbial decomposition, and through free enzymes in the mud liberated from dead cells. Evidence for the existence of sedimentary free enzymes was presented by ZoBell (1939).

The seasonal carbohydrate compositions of sediments and associated aquatic plants from several Minnesota lakes were studied by Rogers (1965). The samples were hydrolyzed in 0.5 N H_2SO_4 for 8 to 10 hours. (The extracts were neutralized with $BaCO_3$ and desalted by "ethanolic precipitation"

and "electronic desalting.") Amounts of sugars were determined by paper chromatography. The total⁵ carbohydrate content was determined by conversion of carbohydrates to furfural with hot 72% sulfuric acid. It is important to note that the 0.5 N acid hydrolysis yields are only 20-30% of the total carbohydrates determined by the furfural test. On pp. 54-58 of the present thesis, I show that the acid hydrolysis yields and the relative proportions of constituent sugars released varies strongly with the concentration of acid used. For example, the yield of the 2.0 N H₂SO₄ hydrolysis is about four times larger than the yield of the 0.5 N H₂SO₄ hydrolysis. In the latter extraction [pentoses] ~ [hexoses], while in the former extraction [hexoses] > [pentoses]. Rogers' results, which are summarized below, must be viewed in light of these findings.

The major sugars detected in the sediments were ribose, mannose, rhamnose, glucuronic acid, galactose, glucose, arabinose, and xylose. The major sugars detected in the plants were glucose, galactose, xylose, arabinose, and glucuronic acid. The sediment extracts obtained by 0.5 N H₂SO₄ contained on the average 9 mg sugar per g dry weight of sediment. The plant extracts contained 400-500 mg sugar per g dry weight of plant material. In the plants the concentration of total hexoses (glucose, galactose, and mannose) was greater than the concentration of total pentoses (arabinose, xylose, and ribose). The reverse was observed for the sediments. No seasonal shifts in composition were observed for either plants or sediments.

⁵Total refers to all carbohydrates detected by a concentrated sulfuric acid method.

The author states that surface sediments contain less than 1% of the total carbohydrates in the standing crop of aquatic plants, although no biomass measurements are mentioned.

In core samples a sharp break in the total sugars (extracted with 0.5 N H_2SO_4) with depth, of the sort observed by Whittaker and Vallentyne (1957), was not found. An irregular temporal variation was observed. The author hypothesized that this variation was due to changes in the rate of contribution, changes in the composition of the organic input, and changes in the conditions of preservation (Eh and pH). The results of the present thesis research support Rogers' hypothesis (e.g., pp. 113-118).

A relative increase in glucose and decrease in arabinose with depth was observed by Rogers (1965). He suggested that this pattern may reflect relative stabilities rather than a long-term change in the input.

The author proposed three mechanisms for the preservation of sedimentary carbohydrates: (1) decreased biological consumption in reducing environments; (2) adsorption onto and into clays; and (3) formation of large molecular or colloidal complexes with lignin, humus, kerogen, and chitin.⁶

Swain and Bratt (1972) compared the carbohydrate geochemistry of sediments from Delaware Bay, Broadkill Marsh (Delaware), and Gulf of California. Free sugars were extracted by refluxing with boiling water for 8 hours. Polysaccharides were hydrolyzed with cold 72% H_2SO_4 followed by refluxing at 100°C with 0.5 N H_2SO_4 for 8 to 10 hours. The 72% H_2SO_4 treatment breaks up resistant polysaccharides (Degens and Reuter, 1964).

⁶ See glossary, Appendix IV.

Sugars were separated by paper chromatography and quantified with a recording densitometer. A few polysaccharides were characterized by enzymatic analyses; the enzymes employed were α and β amylase, cellulase, and laminarase. Polysaccharides of sufficient molecular weight to be detected were present in very low concentrations (< 10 ug/g sediment dry weight); cellulose and laminarose were the polysaccharides most commonly observed.

The sugars detected in all three environments after hydrolysis were: galactose, glucose, mannose, arabinose, xylose, ribose, and rhamnose. In the marsh environment 0.2 to 6.8 mg sugar/g dry weight of sediment were detected after acid hydrolysis; the bay sediments released 0.06 to 0.26 mg/g and the gulf sediments released 1.8 to 3.4 mg/g. Free sugars constituted about 5% of the total (determined by acid hydrolysis) in the marsh sediment, 20-50% of the total in the bay sediments, and 1 to 2% of the total in the gulf sediments.

The authors classified the marsh sedimentary environment as high-energy oxic, and the bay environment as low-energy oxic. Carbohydrate material originating in the marsh was not detected to any great extent in the bay sediment, therefore, it was concluded that this material had undergone degradative oxidation before reaching the bay. The authors do not explain what is meant by degradative oxidation and furthermore they make the untested assumption that carbohydrates are transported out of the marsh.

The gulf environment was classified as low-energy anoxic; it was concluded that carbohydrates were well preserved in this environment due to the lower biological consumption rate. The results of the present thesis (e.g., p. 140) support the conclusion that consumption rates are lower in anoxic environments.

The study of carbohydrates in ancient sediments has been largely conducted by Swain and his associates (e.g., Palacas et al., 1960; Swain, 1963; Swain and Rogers, 1966; Swain et al., 1967; Swain et al., 1968; Swain, 1969).

Swain and Rogers (1966) examined the stratigraphic distribution of carbohydrates in Middle Devonian Onondaga beds of Pennsylvania and New York. The total carbohydrate content of 5 to 10 g of crushed rock sample, was determined by a phenol-sulfuric acid method in which carbohydrates were converted to furfural with 50% H_2SO_4 and detected spectrophotometrically after reaction with phenol. The average total carbohydrate content was 50 mg/kg of rock. Significant variations were attributed to differences in source material, proximity to the cratonic land mass, and conditions of deposition.

Polysaccharides were hydrolyzed in 0.5 N H_2SO_4 for 8 to 10 hours under reflux. Thus, the results of Swain and Rogers (1966) are subject to the same limitations as those of Rogers (1965). The samples were neutralized with $BaCO_3$ and desalted by "ethanolic precipitation" and ion exchange resins; sugars were identified and measured by paper chromatography.

Generally less than 10% of the total (phenol-sulfuric acid) were extracted by this method. Mannose, glucose, and xylose were the dominant sugars detected.

The authors concluded that the pentoses in the Onondaga rocks were dominantly land-derived while hexoses were dominantly marine-derived. This conclusion, however, is not well-established since post-depositional effects of ground water action and metamorphism were not considered.

Analysis of present-day sediments might more clearly define the natural variations in carbohydrate contents in different sedimentary environments; this is one of the goals of the present thesis research.

Swain et al. (1967) examined the distribution of carbohydrates in marine fossils and associated rock matrices. The goals of that research were to discern paleo-environmental factors and evolutionary changes. Extraction techniques were similar to those of Rogers (1965) and Swain and Rogers (1966) above and, hence, were subject to the same limitations. Again, less than 10% of the total was extracted with the $0.5 \text{ N H}_2\text{SO}_4$ treatment.

The range of total carbohydrate content was 4 to 900 mg/kg of sample for the fossils and 15 to 660 mg/kg of rock for the matrices. Hexoses generally predominated in most of the samples. No clear-cut relationship was found between the sugar contents of the fossils and of their associated matrices. Generally, the total carbohydrate concentrations in neritic fossils were approximately equal to those in littoral fossils. The

carbohydrate content in littoral matrices, however, was about 30% greater than in neritic matrices. The authors stated that littoral sediments received land-derived particulate organics and are therefore relatively enriched in carbohydrates.

The effects of weathering and percolating ground-water were not assessed. The effect of metamorphism was considered for one sample; a Devonian shale was heated ('metamorphosed') for two hours at 150-225°C; the total carbohydrate yield increased up to a point and then decreased. The effect of this treatment on the relative abundances was not determined.

In light of the errors arising from contamination, metamorphism, and incomplete extraction, conclusions drawn from the above studies of sedimentary rocks must be considered highly speculative.

Prashnowsky *et al.* (1961) studied the distribution of sugars in 4 m sediment core from the Santa Barbara Basin (off California). The core contained grey-green, sulfide-rich, laminated sediment; interspersed turbidite and oxic sediment bands were noted. Although the water above the sea floor is presently anoxic, bottom oxygen values must occasionally have been high enough to support benthic life to produce the oxic layers. The carbohydrate analyses were made with no selection according to sediment type.

Sugars were extracted with an unspecified H_2SO_4 technique, followed by desalting on ion exchange resins. Separation and quantification was accomplished by paper chromatography. The total sugars detected ranged

from 0.2 to 2.2 mg/g dry weight; the percent of the total organic matter represented by extracted sugars was 0.6 to 4.3% (usually 2-4%). No apparent correlations between sugar concentration, grain size, moisture and CaCO_3 contents were observed.

Galactose and mannose were most abundant, followed by glucose and rhamnose; the pentoses, ribose, xylose, and arabinose, were least abundant. Four different temporal patterns were discerned: (1) one followed by galactose and mannose; (2) one followed by glucose and rhamnose; (3) one followed by xylose and arabinose; and (4) one followed by ribose. The authors speculated that these patterns were probably caused by variations in the supply of organic matter and by changes in Eh either at the time of deposition or during early diagenesis. An alternative explanation, involving the natural chromatographic separation of organic molecules along clay surfaces during compaction, was also suggested. In view of the variations in the sediment types (anoxic, oxic, turbidite) and the indiscriminant sampling, this latter explanation is probably unnecessary. In fact, in a later section I argue that the mobility of potentially soluble carbohydrates in sediment is strongly inhibited by binding with metals (p. 118).

From the low relative abundance of glucose in the sediment, compared to continental plants, the authors concluded that allochthonous (land-derived) carbohydrates were insignificant sources for sedimentary carbohydrates. Marine algae was thought to be the most probable source.

A study of carbohydrates in marine oxic sediments from the San Diego Trough was presented by Degens *et al.* (1963). The core was approximately 3 m long (\sim 35,000 years B.P. at the bottom) and consisted of hemipelagic light green mud. A positive Eh (+200 to +300) was observed throughout.

The extraction methods involve treatment of sediment in cold 72% H_2SO_4 and further hydrolysis in 1 N H_2SO_4 followed by desalting and detection by paper chromatography. The concentration of total acid extractable sugars decreased from 850 mg/kg (dry weight) in surface sediments to 110 mg/kg at 3 m. In surface sediments extracted sugars plus amino acids were approximately 15% of the total organic matter; at 3 m they represented less than 2%.

The authors pointed out that differences in relative abundances and concentrations of individual sugars between an oxidizing environment (San Diego Trough) and a reducing environment (Santa Barbara Basin) are not very strong. It was suggested that in both environments sugars are consumed as an energy source and are not otherwise metabolically altered or transformed to any great extent. The results of the present thesis research (Chapter V) confirm that the relative abundances of sugars in oxidizing and reducing environments are similar. However, relative to total organic carbon, sugars are enriched in reducing environments and depleted in oxidizing environments, which suggests that the degree of consumption of carbohydrates in oxidizing environments is considerably higher.

Degens et al. (1963) observed that total hexoses and total pentoses followed similar depth distribution patterns. However, a linear decrease in cellulose-glucose was also observed which suggests that even when sugars are in this stable combined form, they are biologically consumed in oxic environments.

From the presence of phenolic compounds (lignin derivatives), a δC^{13} value of -21.8 for the humic fraction, and an amino acid pattern within the humic fraction similar to that found in soils, the authors deduced a terrigenous source for the organic matter in the San Diego Trough. This conclusion contradicts that of Waksman (1933) and Prashnowsky (1961).

Degens et al. (1964) proposed the existence of labile and refractory carbohydrate inputs to sediment. The labile input is thought to consist of indigenous algal material which is consumed rapidly in oxic sediments. The refractory input is attributed to clay-sugar complexes and humic-sugar complexes which the authors considered to be principally derived from terrigenous sources. This proposed bimodal organic input is similar to that presented by Waksman (1933).

Carbohydrate analyses of sediment from the experimental Mohole were presented by Rittenberg et al. (1963). The coring device penetrated 2.5 m of red clay and 173 m of calcareous and siliceous hemipelagic ooze. The oldest sediments were Middle Miocene in age. The sediments were oxic throughout ($Eh \sim +300$). The organic carbon varied between 0.2 and 2%, which are typical values for oceanic sediment (Bordovskiy, 1965).

Sugars were extracted as follows: 5-10 g of dried sediment were treated in 72% H_2SO_4 for one hour at 4°C followed by dilution to 1 N and further hydrolysis for 8 hours. BaCO_3 was added for acid neutralization and ion-exchange resins were used to desalt the samples. Sugars were identified and measured by paper chromatography. The sugars detected were galactose, glucose, mannose, rhamnose, arabinose, xylose, and ribose. Total hexoses always exceeded total pentoses; the depth distribution patterns of the two groups of sugars were nearly identical.

The acid extractable sugars represented about 4% of the organic matter in the surface sediments and about 0.1% at a depth of 50 m. Below 50 m the value fluctuated around 0.1%. Free sugars (ethanol-extractable) were detected only in the upper meter of the core and represented less than 1% of the total acid extractable sugars.

Modzeleski et al. (1971) employed gas chromatographic-mass spectrometric (g.c.-m.s.) analysis of trimethylsilyl derivatives to determine the carbohydrate composition of Santa Barbara Basin sediment. Carbohydrates were extracted from exhaustively washed sediment (p. 119) by a sulfuric acid hydrolysis method followed by neutralization with $\text{Ba}(\text{OH})_2$ and desalting on ion exchangers.

Identification and quantification of sugars by g.c.-m.s. is not only more accurate and sensitive than paper chromatographic methods used by previous investigators, it also permits independent identification of sugar

peaks. Prior to the study of Modzeleski et al. (1971) no absolute identification of sedimentary sugars had been performed. This lack of positive identification probably resulted in either mis-identification or lack of detection of certain sugars. For example, Modzeleski et al. (1971) determined that fucose (an important algal sugar) is present in their samples in concentrations comparable to that of glucose; Prashnowsky et al. (1961) detected only traces of this 'sugar' in Santa Barbara Basin sediments. In other investigations this sugar has remained completely undetected.

In addition to the problem of sugar identification, none of the above investigators thoroughly ~~examined their~~ extraction techniques for errors arising from contamination, incomplete extraction, and poor reproducibility. Furthermore, direct comparison of the results of different investigators has proved difficult because of the variations in extraction techniques and means of identification. For example, free sugars were extracted in either boiling or cold 70% ethanol for 5 minutes to eight hours; in a few instances distilled water alone was used as the extractant (Vallentyne and Bidwell, 1956; Whittaker and Vallentyne, 1957; Swain, 1969). Hydrolysis techniques varied widely; e.g., Vallentyne and Bidwell (1956) used .25 N HCl for one hour at 100°C; Rogers (1965) used .5 N H₂SO₄ for 8-10 hours at 100°C; Swain and Bratt (1972) used the technique of Rogers (1965) but treated the sediment in cold concentrated H₂SO₄ for one hour prior to hydrolysis in .5 N H₂SO₄; Degens et al. (1963) treated sediment in cold concentrated H₂SO₄ for 2-4 hours with further hydrolysis in 1.0 N H₂SO₄

for 8 hours. Modzeleski et al. (1971) extracted sediment in 2 N H_2SO_4 for 90 minutes at 100°C followed by centrifugation and re-extraction in 2 N H_2SO_4 for an additional 60 minutes.

Neutralization was usually accomplished by addition of either BaCO_3 or Ba(OH)_2 . A variety of desalting techniques were employed: "ethanolic precipitation", ion exchange resins (different types), and "electronic desalting".

Different eluents and different sugar location reagents of varying sensitivities were employed in the paper chromatographic methods.

If the state of the art of sugar extraction from sediment had to be summarized briefly, that summary would have to be: crude, primitive, and uncertain.

2. GOALS OF THE RESEARCH

The goals of the present thesis have been oriented toward elucidation of the following questions:

- (i) What is the carbohydrate composition of sediment in different environments (e.g., deep-sea oxic; shallow-sea oxic; deep-sea anoxic; fresh-water anoxic; brackish-water anoxic, etc.)?
- (ii) How does the environment at the sediment-water interface affect the composition of the carbohydrate input?
- (iii) How do sedimentary carbohydrates compare to plankton carbohydrates?
- (iv) How do metal-carbohydrate interactions and biological degradation affect the diagenesis of carbohydrates in recent sediments?
- (v) Can fossil carbohydrates be used as a means to elucidate paleoenvironments?

From the previous section ('Historical Review') it is evident that before investigating these problems it is first necessary to establish reliable extraction procedures. Therefore, in the following chapter the various extraction techniques will be thoroughly examined in order to determine lability of sugars, sources of contamination, maximum yields, and reproducibility.

Establishment of a chromatographic sugar analyzer system and the positive identification of sedimentary sugars are also described.

CHAPTER II

ANALYTICAL PROCEDURES

1. AUTOMATIC SUGAR CHROMATOGRAPHY

The distribution and diagenesis of carbohydrates in sediments has been largely ignored by investigators in the field of organic geochemistry. The primary hindrance to this research has been the lack of appropriate analytical techniques to: i) quantitatively extract sugars from sediment and ii) separate and identify the component sugars.

The latter difficulty has been resolved through the advent of automatic sugar analyzer systems which are based on the design of the liquid chromatographic amino acid analyzer (Moore and Stein, 1951). However, in contrast to the ion exchange technique used in amino acid analyzers, the sugar analyzer employs a partition chromatographic technique. Other sugar instrumentation techniques, such as gas chromatography-mass spectrometry, paper chromatography, and thin layer chromatography are less satisfactory; a review of sugar instrumentation is presented in my Master's Thesis (Mopper, 1970).

The automatic sugar analyzer described in this section was constructed as part of my Master's Thesis research. Therefore, only a summary will be presented here.

Several investigators have constructed automatic sugar analyzers (Larsson and Samuelson, 1965; Kesler, 1967) and a system is available

from Technicon Corporation. These systems suffer from three flaws: (1) concentrated sulfuric acid is employed in the dye reaction (e.g., p. 41); (2) the detection limit is only 10^{-8} to 10^{-9} moles; and (3) the use of multi-channel peristaltic pumps results in poor reproducibility due to rapid exhaustion of pump tubing. The above difficulties have been avoided in the present system (Mopper and Degens, 1971).

A schematic diagram of the sugar analyzer is depicted in Figure 1. A 200 cm nylon column (i.d. 0.28 cm) filled to 180 cm with Technicon type S resin (8% cross-linked, ion-exchange styrene-divinylbenzene beads, $20\ \mu$ in diameter) is placed in a glass heating jacket through which water at 76°C is circulated by a Haake type F constant-temperature circulator. The resin bed is recessed several cm in the heating jacket to heat the eluent to the temperature of the column. Another Haake circulator is employed in the reaction bath. A Gilford 2000 spectrophotometer with a 5 mm flow-through cuvette is used for all color recognition and recording. A 3 meter reaction coil of Teflon spaghetti tubing (0.0027 cc/cm capacity) is placed between column exit and cuvette exit. Tube fittings are stainless steel (Swagelok). The eluent and dye are pumped with Beckman Accu-Flo piston pumps.

The column was filled according to techniques described by Samuelson (1963). The resin, initially in the borate form, was converted to the sulfate form by pumping 200 ml 0.5 M Na_2SO_4 through the resin bed. The column was washed with water and conditioned for 8 hr by pumping the

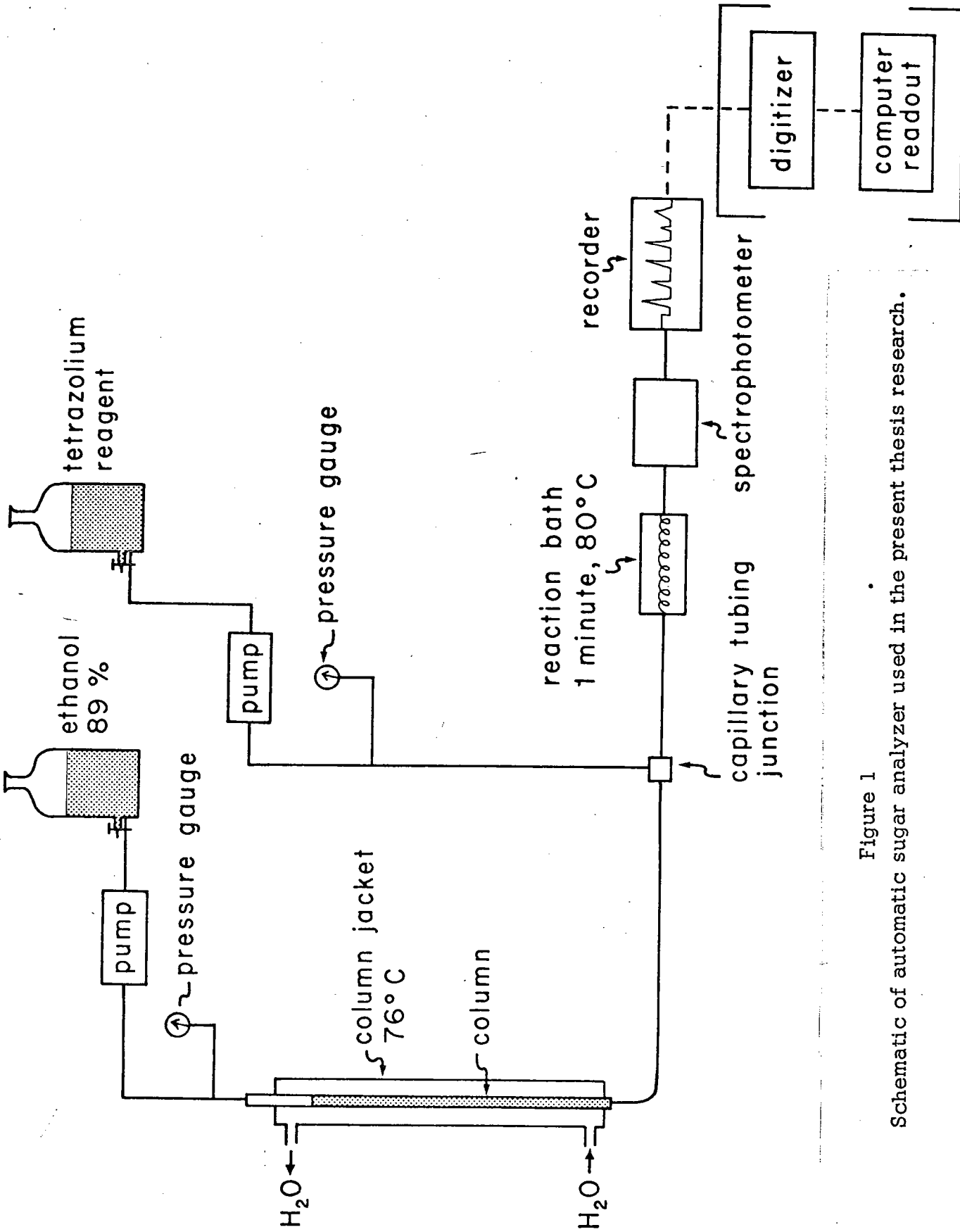

Figure 1
Schematic of automatic sugar analyzer used in the present thesis research.

eluent at the flow rate and temperature used during analyses.

The eluent is made by diluting 95% ethanol (not denatured) to 88% with distilled water.

A 0.50 M solution of Na_2SO_4 is employed for column regeneration.

The column is repacked and regenerated about every 50 samples.

Reagent grade sugars were purchased from Mann Research Laboratories.

A standard was prepared by dissolving 0.1 gm each of the following sugars in 100 ml H_2O : deoxyribose (d-Ri), rhamnose (Rh), ribose (Ri), arabinose (A), xylose (X), mannose (M), galactose (Ga), and glucose (Gl).

The dye consists of 2.0 gm tetrazolium blue (p-anisyltetrazolium chloride, K & K Laboratories) in 1 liter of 0.18 M NaOH. The tetrazolium blue is recrystallized several times from methanol until the melting point (with decomposition) is 239-240°C (Cheronis and Zymaris, 1957).

Samples are injected with a micro-syringe into the top of the resin bed. The eluent pump (set at .36 ml/min) is connected to the top of the column and the dye pump (set at .12 ml/min) is connected to the column eluate via a mixing chamber. Figure 2 depicts a chromatogram of a standard sugar solution containing 15 μg of each sugar.

The elution order and retention time of individual monosaccharides were determined by spiking one sugar at a time into the standard. The system was calibrated by measuring peak areas. Aliquots of the standard solution (5, 10, 15, 20, 25 μl) were analyzed. Figure 3 suggests that most sugars react in a similar manner with the tetrazolium dye.

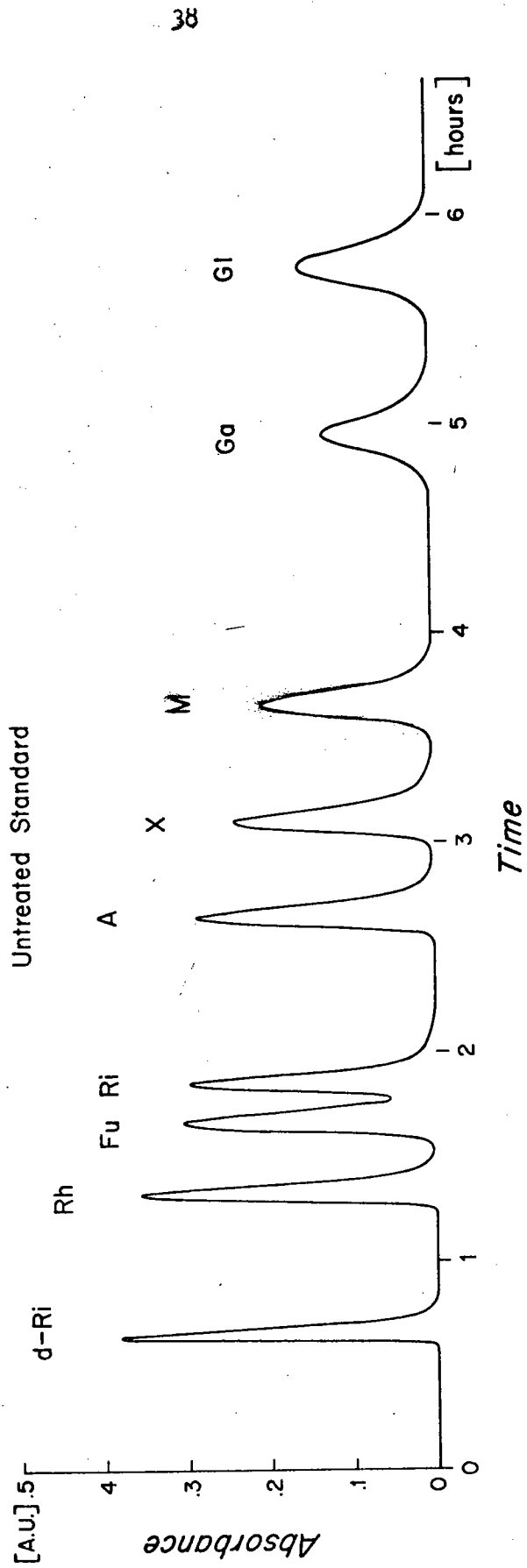

Figure 2

Chromatogram of a standard sugar solution. The concentration of each sugar in the solution is 1000 $\mu\text{g/ml}$. Each peak represents 15 μg of d-Ri: deoxyribose, Rh: rhamnose, Fu: fucose, Ri: ribose, A: arabinose, X: xylose, M: mannose, Ga: Galactose, and Gl: glucose.

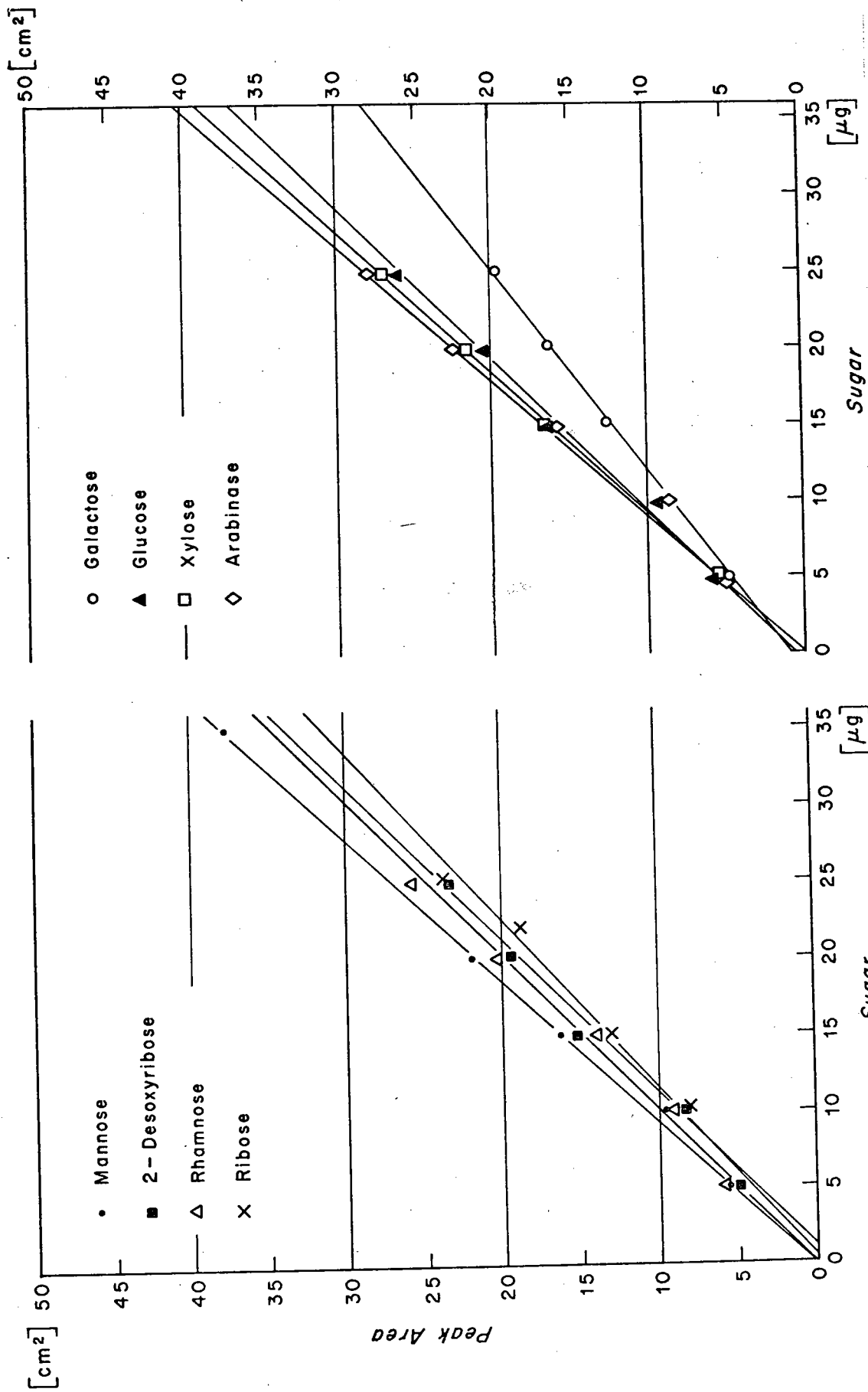

Figure 3

Quantification of sugar analyzer by peak areas. Slopes of most sugars are nearly identical, which indicates that most sugars react in a similar manner with the tetrazolium dye. A full-scale absorbance of .4 absorbance units was employed.

All absorbances are read at 520 m μ . Beer's Law holds for sugar concentrations of less than 50 $\mu\text{g/ml}$. The detection limit is 10^{-10} moles of sugar at a full-scale absorbance of 0.10 absorbance units. This system gives reproducible results of better than $\pm 5\%$ at the 10^{-8} mole level.

The following parameters were investigated during the construction of the sugar analyzer:

a. Type of Eluent

Two elution methods are in common use: NaCl/borate eluent and ethanol/water eluent. The ethanol eluent is employed in the present system because the tetrazolium blue-sugar reaction fails to give reproducible results in the presence of NaCl/borate solutions.

Ethanol concentrations greater than 92% results in excessive elution volumes and peak broadening. At concentrations under 85%, peaks are insufficiently resolved to permit quantitative evaluation.

b. Eluent Flow Rate

High flow rates lead to decreased elution times and poor resolution. Xylose and mannose are poorly resolved at a flow rate of 1.2 ml/min, but are completely resolved at < 0.6 ml/min. Further, at the faster flow rate a higher pressure drop across the column is measured (~ 700 psi). In the present system the pressure drop is about 500 psi.

c. Resins

Several strong anion- or cation-exchange resin can be used; fine-grained resins of uniform particle size gave the best resolution

(Mopper, 1970). For this reason Technicon resin (type S, 20 μ) is employed, although Dowex 21-K (1-16 μ) in chloride and sulfate forms and Dowex 50 W-X8 (14-17 μ) in potassium, sodium, and lithium forms have also been applied with success (Jonsson and Samuelson, 1967; Samuelson and Stromberg, 1968).

Separation of sugars is attributable to their partition between water held in the resin beads and water in the exterior solution. The more polar sugar molecules are held more strongly by the resin. The general order of elution is: deoxypentoses, deoxyhexoses, pentoses, hexoses, and disaccharides.

d. Dimensions of Resin Bed

Long columns (>100 cm) with narrow diameters (<0.3 cm) yield the greatest sensitivity and resolution.

e. Column Temperature

Increasing the column temperature increases the rate of diffusion into and within the resin beads and: (i) reduces the time for analysis, (ii) reduces the pressure drop across the column, and (iii) increases the resolution. A temperature of 76°C, which is just below the boiling point of ethanol, is used.

f. Dye Reagent

The usual dyes employed in automatic sugar analyzers are corrosive and dangerous to manipulate (i.e., orcinol-sulfuric acid, anthrone-sulfuric acid, and phenol-sulfuric acid). To avoid these difficulties a noncorrosive,

yet highly sensitive, dye was developed: an alkaline 0.2% solution of tetrazolium blue (Cheronis and Zymaris, 1957). Until now this dye was inapplicable in automatic sugar analyzers because of the precipitation of diformazan which clogs the capillary tubing:

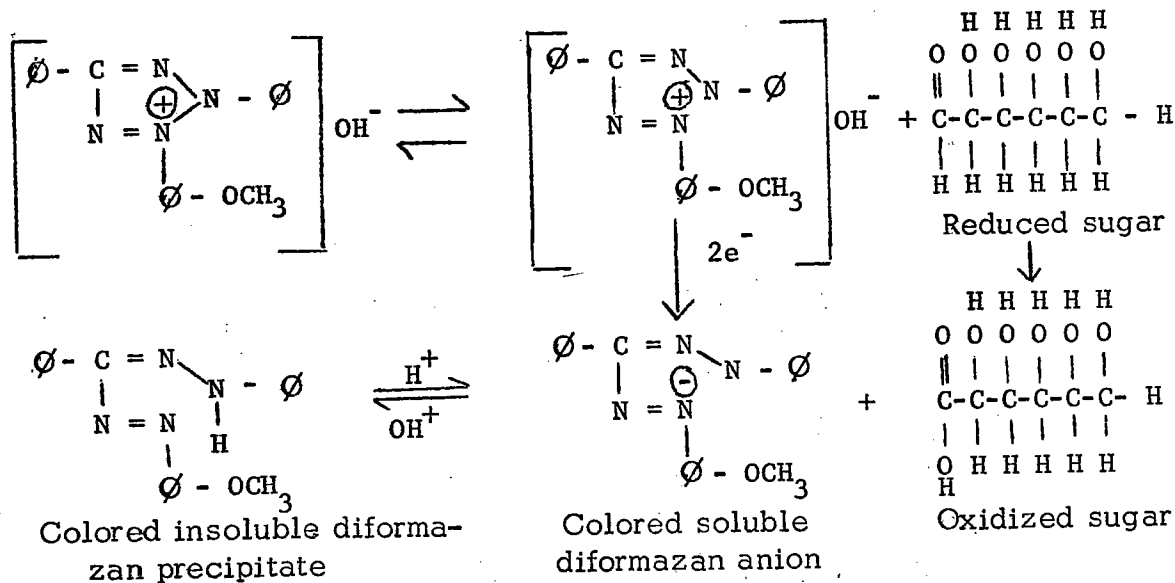

To overcome these difficulties solvents such as dioxane, acetone, and ethanol were added to the tetrazolium blue solution to test their effectiveness in preventing the precipitation of diformazan. Success was achieved only with ethanol; fortunately ethanol is a good eluent for the separation of sugars. By adjusting eluent and dye flow rates maximum dye sensitivity was achieved.

2. APPLICATION OF SUGAR ANALYZER TO SEDIMENT

Presented in this section are various lines of evidence which show that the compounds isolated from sediment and recorded spectrophotometrically are indeed sugars.

a. Clean-up Procedure

Both the sediment extraction procedure and the sugar analyzer system are highly selective for reducing sugars. For example, hydrolysis in 1.8 N HCl eliminates all acid-labile compounds; the ion exchange resins used for desalting eliminates all compounds which are highly polar such as amino acids, fatty acids, uronic acids, glyconic acids, hexose amines, etc. Only compounds capable of reducing the tetrazolium reagent are detected on the sugar analyzer, hence sugar alcohols (mannitol, sorbitol, etc.) and glycaric acids elute undetected. Furthermore, only those reducing compounds which are eluted between a half hour and five hours are examined; compounds which are held weakly by the resin, such as furfural and furfural derivatives, are eluted early in the chromatogram; compounds which are held strongly by the resin, such as disaccharides and aromatic aldehydes (lignin derivatives), are eluted as very broad, almost imperceptible peaks many hours after the monosaccharides.

b. Co-chromatography

Argentine Basin sediment was spiked with the standard prior to extraction in order to determine the destructive effects of different extraction techniques. The peaks from both the sediment and spiked sugars co-chromatograph

TABLE 1
 Spiking of Argentine Basin sediment (2g) with a standard sugar solution
 (numbers represent peak areas in cm²)

A. HCl Hydrolysis

Sugars:	Rh	Fu*	Ri	A*	X	M	Ga*	G1
unspiked sample	6.6	7.8	2.7	7.0	6.8	10.9	14.0	14.8
spike added	9.1	--	8.3	--	9.1	9.0	--	9.0
spiked sediment	15.6	8.2	7.7	7.4	15.4	19.4	13.9	22.9
spike found	9.0	+4	5.0	+4	8.6	8.5	-1	8.1
% of spike destroyed	1	--	40	--	5	6	--	10

% average deviation for spiked sugars: 12%

B. Hydrolyzed EDTA Extraction

unspiked sample	5.0	5.6	2.8	3.8	5.9	5.2	9.0	7.2
spike added	9.1	--	8.3	--	9.1	9.0	--	9.0
spiked sediment	13.5	5.5	9.4	3.8	14.1	14.3	8.7	16.3
spike found	8.5	-1	6.6	0	8.2	9.1	-3	9.1
% of spike destroyed	7	--	20	--	10	0	--	0

* not spiked

% average deviation for spiked sugars 7%

exactly. Table 1⁷ shows the results of this experiment. Changes in various parameters of the sugar analyzer system, e.g., column flow rate and column temperature, do not alter this exact correspondence of peaks.

c. Absolute Identification of Sugars by Gas Chromatography-Mass Spectrometry

Figure 4 shows the results of an intercalibration experiment between my liquid chromatography system and the gas chromatography-mass spectrometry system described and operated by Modzeleski et al. (1971). It is important to note that all the gas chromatographic peaks were identified by comparing their mass spectral patterns with those of standard sugars; thus, an absolute identification was obtained.

In Figure 4a analyses of the same Santa Barbara Basin sediment sample ("50 years") were performed in both laboratories with the identical extraction procedure (Modzeleski et al., 1971). The linear correlation between the results as shown in the figure conclusively demonstrates that the sediment peak_λ^s recorded spectrophotometrically are sugars. In Figure 4b, the yields of the Modzeleski extraction procedure are plotted against the yields of the extraction procedure employed in the thesis research. From this figure it can be seen that my hydrolysis technique is more efficient for the extraction of glucose, galactose, and mannose.

A similar correlation of results is observed for another sediment sample (Santa Barbara Basin "750 years"), as shown in Figure 5a,b.

⁷Table 1 is discussed in the next section.

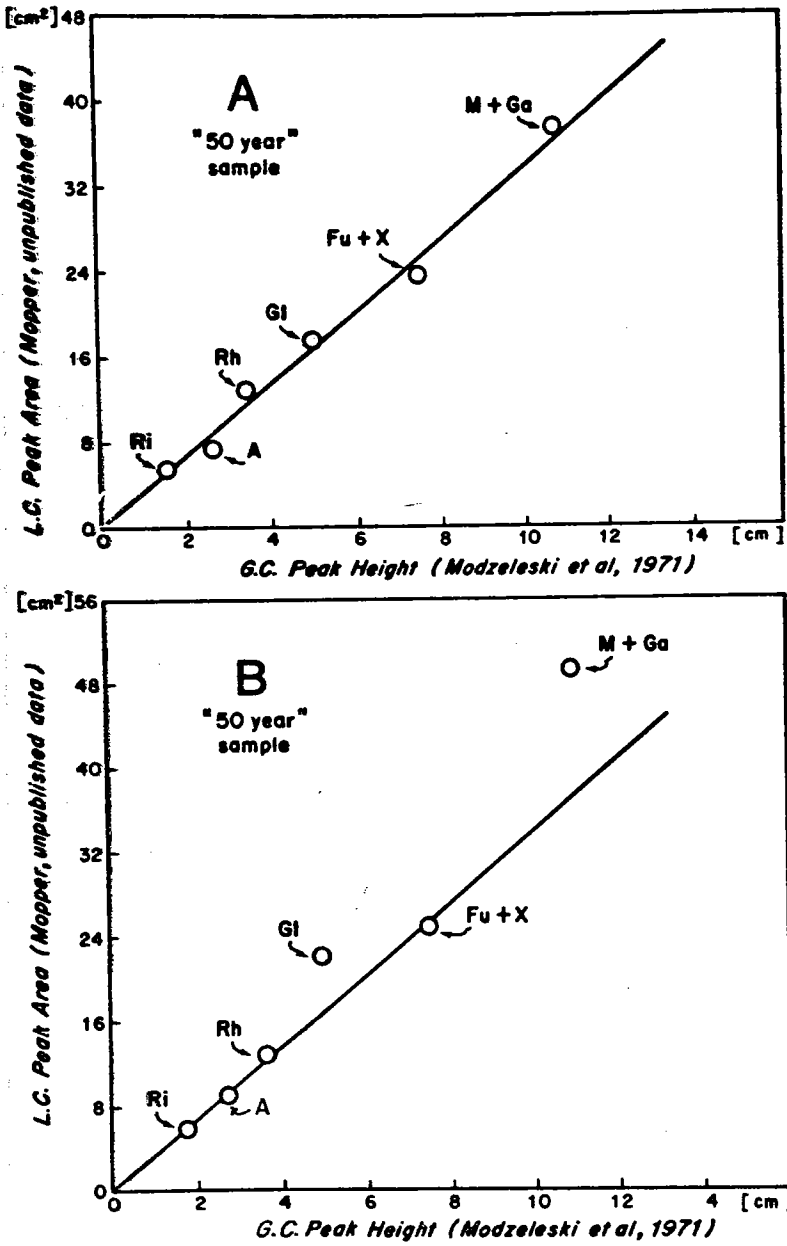

Figure 4

Caption on following page.

Figure 4

(a) Intercalibration between two laboratories of sugar analytical techniques. An identical extraction procedure was employed in both laboratories: 1 g of exhaustively washed Santa Barbara Basin sediment ("50 years") was hydrolyzed at 100°C for 90 minutes in 2.0 N H₂SO₄; the sample was centrifuged and re-hydrolyzed for 60 minutes in 2.0 N H₂SO₄ and then centrifuged again; the combined liquid fractions were deionized and analyzed by G.C.-M.S. (Modzeleski et al., 1971) and by the present liquid chromatographic system.

(b) The results of the Modzeleski et al. (1971) extraction procedure (above) are plotted against the results of the extraction procedure used in the present thesis research: 1 g of sediment was hydrolyzed at 100°C for 180 minutes in 1.8 N HCl followed by centrifugation and deionization (see the following section for details). The extraction procedure used in the present thesis research releases larger quantities of glucose, mannose and galactose. The slope of the line in this figure is the same as in (a). Notation as in Figure 2.

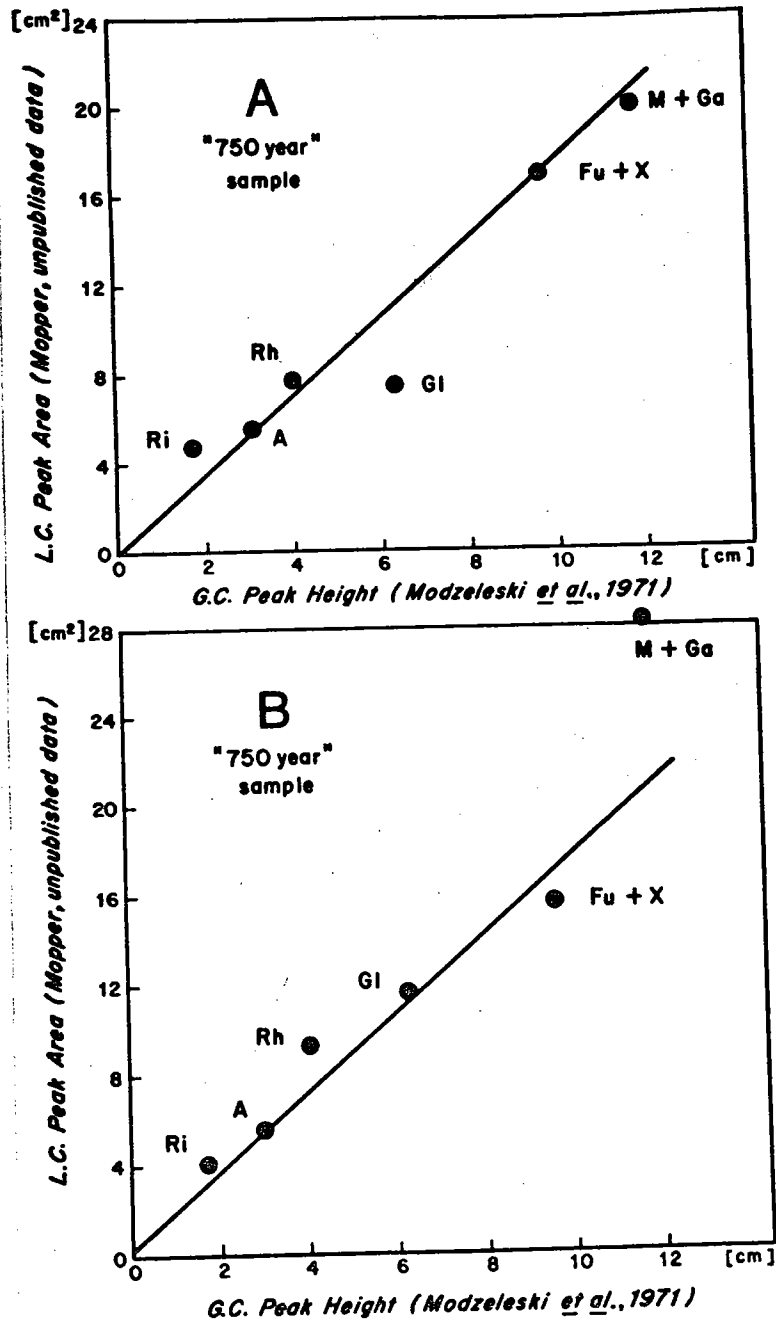
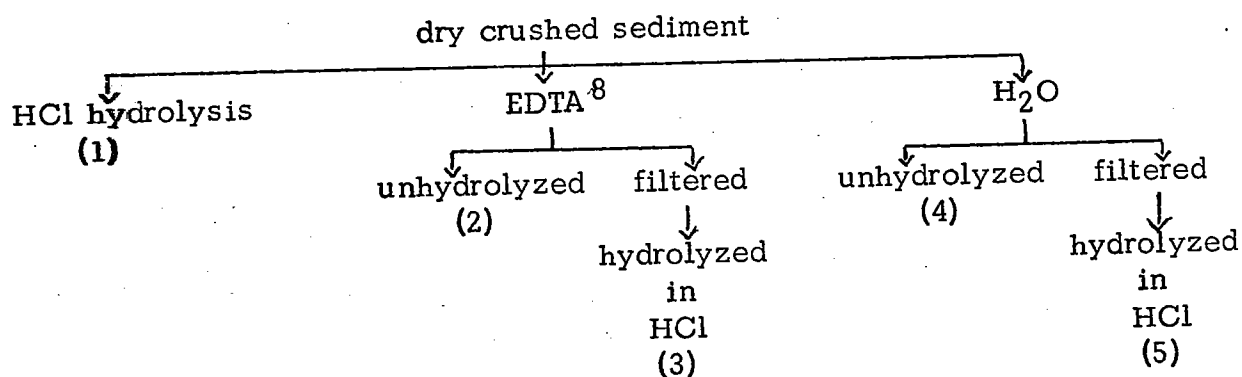

Figure 5

(a) and (b) Intercalibration results for Santa Barbara Basin sediment sample "750 years". See caption of Figure 4 for details. Notation as in Figure 2.

3. EXTRACTION OF CARBOHYDRATES FROM SEDIMENT: ACID HYDROLYSIS

In the previous section it was demonstrated that the compounds extracted from sediment and detected spectrophotometrically are, indeed, sugars. In the following sections, the various extraction techniques employed in the research are presented in detail. The following extraction methods are used:



Most of the sediment samples were analyzed by methods 1, 2, and 3. The H₂O extracts (methods 4 and 5) were used less frequently since these extracts yielded less information. Therefore, the extracts obtained by methods 1, 2, and 3 will be examined in greater detail in the following sections.

A hypothetical acid extraction procedure was devised in order to delineate sources of error arising from contamination, destruction and incomplete extraction. Standard monomeric sugar solutions, aliquots of a Black Sea sediment (core 1474K, 120-130 cm) and aliquots of Argentine Basin sediments (AII 60, leg 2, st. 21, 20-50 cm and 30 cm) were used to test the following extraction procedure:

⁸EDTA = ethylenediaminetetraacetic acid

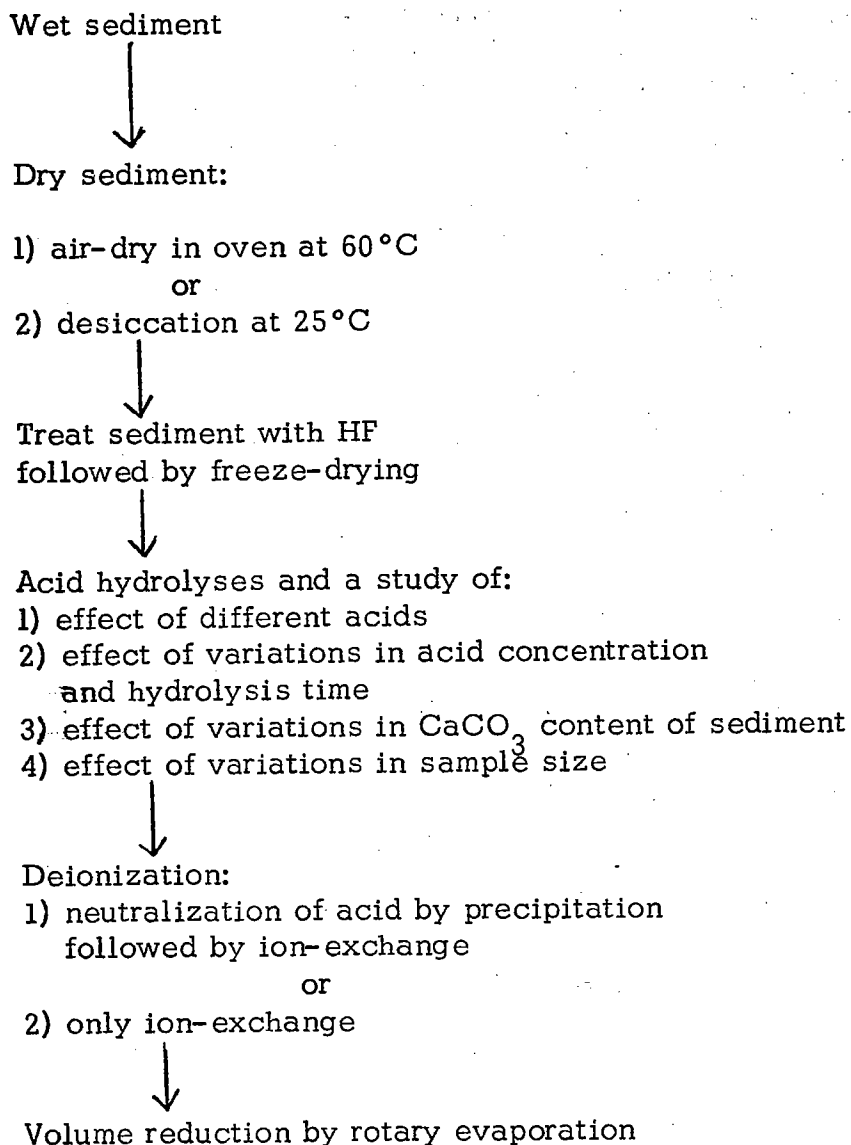

a. Sample Drying Procedure

Two sediment drying techniques were examined: i) desiccation in a mild vacuum (~5 torr) for 20 hours at room temperature and ii) oven drying at 60°C for 20 hours. Each technique was tested with an identical standard mixture of monomeric sugars (1 mg/ml) and organic-free kaolinite. Figures 6a, b, and c indicate that oven drying induces losses of 40 to 90% of

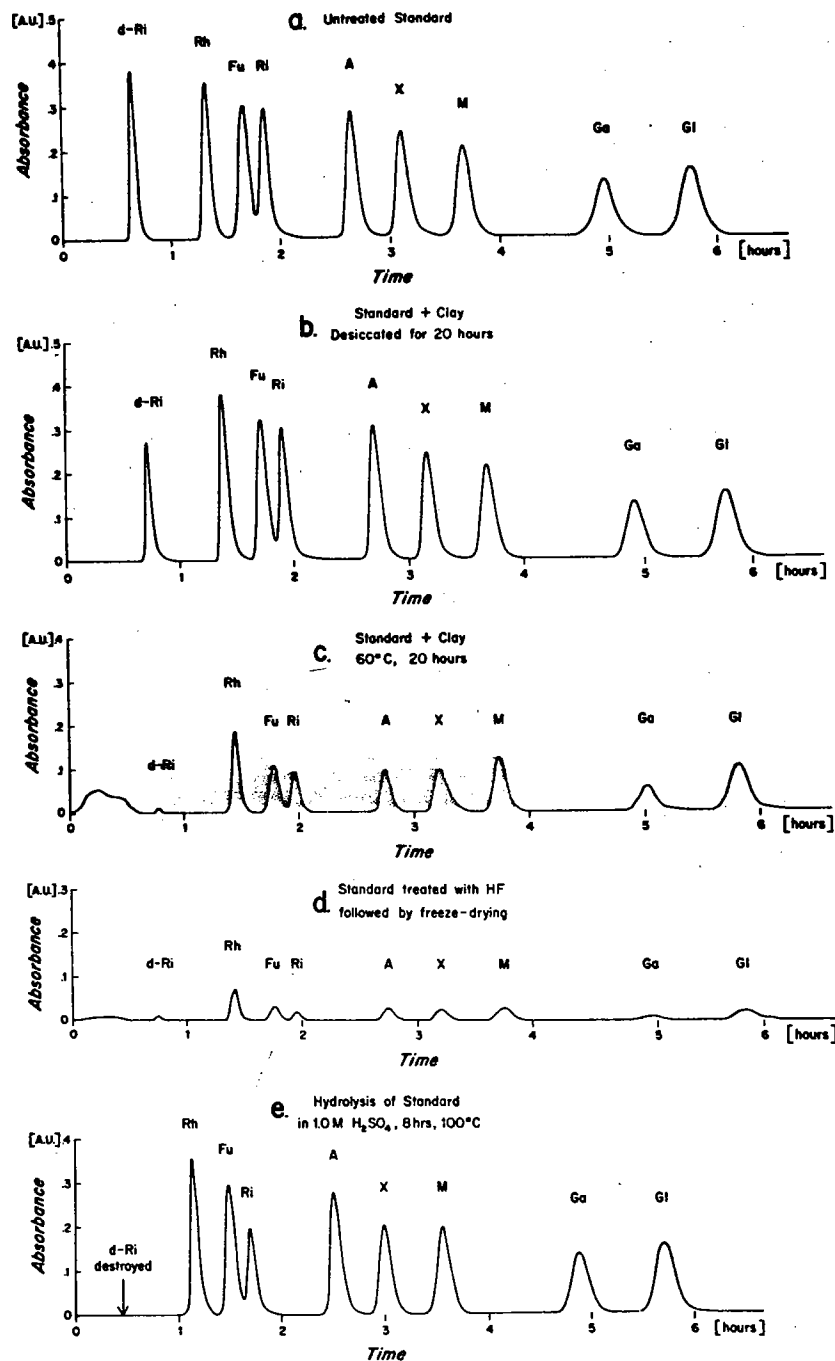

Figure 6

Tests of carbohydrate extraction procedures using a standard solution (the concentration of each sugar in this solution was 1000 $\mu\text{g}/\text{ml}$). Initially 1 ml of the standard was used for each experiment; an amount equal to 15 μg of each sugar (assuming no loss occurred) was analyzed. Comparison of chromatograms 'b' through 'e' to the untreated standard 'a' reveals relative losses due to the experimental treatments; notation as in Figure 2.

monomeric sugars. These losses are probably less significant for sediment samples because most carbohydrates are not present as free monomers (the unhydrolyzed H₂O extraction releases <2% of the sugars released by acid hydrolysis as shown in Chapter IV), but are either insoluble polymers (cellulose, etc.) or are incorporated in humic-type complexes. Since the vacuum desiccation technique is milder, it is employed in the present research.

b. HF Pretreatment

Stevenson and Cheng (e.g., 1970) determined that amino acid yields are increased ~~when~~ sediment is treated at room temperature with a 5 N HF-0.1 N HCl solution prior to hydrolysis. This method was tested in order to determine its applicability to carbohydrate extraction procedures. One ml of a standard monosaccharide solution (9 sugars, 1 mg/ml each) was added to 4 ml of a 5 N HF-0.1 N HCl solution and sealed under nitrogen. The solution was placed on a vibrator (as were the samples containing sediments) for 24 hours at room temperature and then freeze-dried. Figures 6a and d indicate that approximately 80% of the sugar standards were eliminated by these operations. Most of this destruction was probably the result of sugar condensations which were induced by the high vacuum (<.5 torr) of the freeze-drying apparatus. Therefore, until the analytical difficulties encountered during HF pretreatment are resolved, this method is inapplicable to carbohydrate extractions of sediment. I assume, however, that for most sediments the quantity of carbohydrates incorporated into the clay

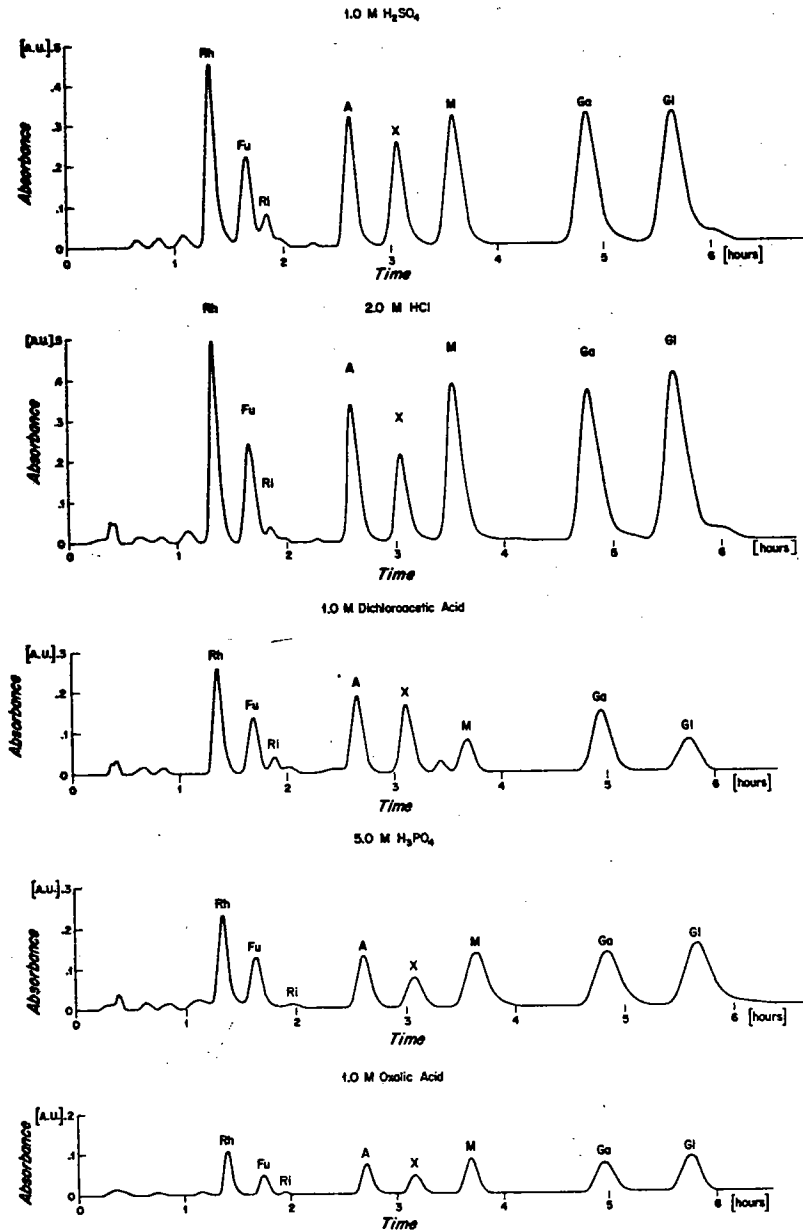

Figure 7

Extraction of carbohydrates from equal aliquots of a Black Sea sediment sample (core 1474K, 120-130 cm). The identical extraction procedure was employed for each chromatogram, therefore, the difference in sugar recoveries is directly related to the hydrolysis efficiency of the acids tested. Notation as in Figure 2.

fraction is negligible as was demonstrated for the amino acids by Mopper and Degens (1972).

c. Acid Hydrolyses

The following acids were tested for their hydrolysis efficiency:

1 M H_2SO_4 , 2 M HCl, 5 M H_3PO_4 , 1 M oxalic acid, and 1 M dichloroacetic acid. One gram aliquots of sediment from Black Sea core 1474 K (120-130 cm, dried in a vacuum desiccator and crushed to less than .25 mm) were hydrolyzed under nitrogen in 10 ml of the above acids at 100°C for eight hours. The samples were then centrifuged, deionized, and reduced to a standard volume. Figure 7 indicates that the order of sugar recovery for the different acids is: sulfuric acid \approx hydrochloric acid > dichloroacetic acid \approx phosphoric acid > oxalic acid.

Figures 8 and 9 show the effect of variations in hydrolysis time and acid concentration of H_2SO_4 and HCl on the sugar yield from the above Black Sea sediment. Optimal extraction parameters are either 1.5-1.8 M HCl for 2-3 hours or 1.1-1.3 M H_2SO_4 for 4-5 hours. Thus, reproducible extractions are achievable if the acid concentrations and hydrolysis times are within the plateau regions of the figures as shown in Table 2. From this table can be seen that individual sugars demonstrate different reproducibilities. These differences appear to be related to differences in sugar lability. For example ribose, which is very labile, shows a \pm 30% reproducibility; glucose, on the other hand, shows only a \pm 2% reproducibility. The overall reproducibility is about \pm 10%. Considering the general

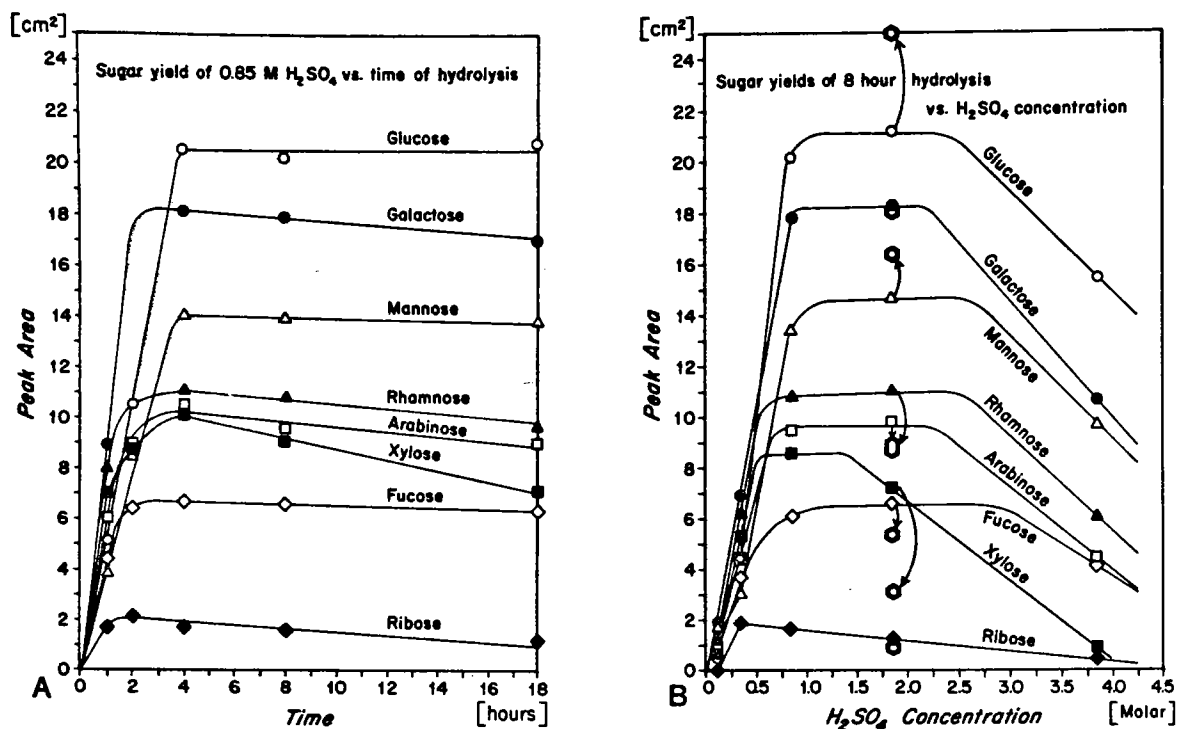

Figure 8

(a) Determination of the optimal hydrolysis time for 0.85 M H₂SO₄. Equal aliquots of a Black Sea sediment sample (core 1474K, 120-130 cm) were extracted for varying time intervals. A minimum of 4 hours is required for optimal extraction.

(b) Determination of the optimal H₂SO₄ concentration for the extraction of the above Black Sea sediment. Hydrolysis time was 8 hours for each test. The \odot notation depicts a sample which was hydrolyzed with 98% H₂SO₄ at 0°C for 2 hours and then diluted to 1.85 M for further hydrolysis. (Plateau regions are somewhat exaggerated for clarity.)

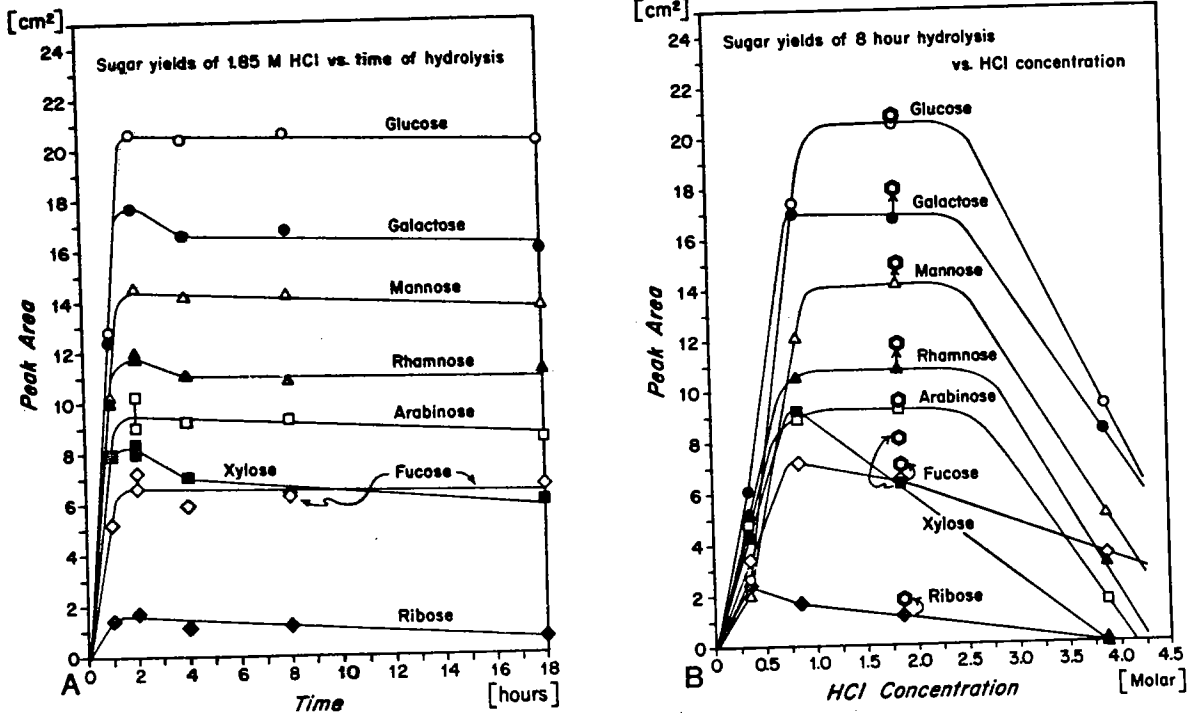

Figure 9

(a) Determination of the optimal hydrolysis time for 1.85 M HCl. Equal aliquots of the above Black Sea sediment were employed for each test. A minimum of 2 hours is required for optimal extraction.

(b) Determination of the optimal HCl concentration for the extraction of the above Black Sea sediment. Hydrolysis time was 8 hours for each test. The \odot notation depicts a sample which was hydrolyzed with 12 M HCl at 0°C for 2 hours and then diluted to 1.85 M for further hydrolysis. (Plateau regions are somewhat exaggerated for clarity.)

TABLE 2
EXTRACTION OF CARBOHYDRATES BY ACID HYDROLYSIS OF 1 g ALIQUOTS OF BLACK SEA CORE 1474 K (120-130 cm)
(peak areas in cm²)

Extraction Parameters	Rh	Fu	Rl	A	X	M	Ga	G1
1.85 M HCl 2 Hours	11.9	6.6	1.7	10.2	8.4	14.9	18.0	21.7
1.85 M HCl 2 Hours	11.7	7.2	1.7	9.0	7.9	14.1	17.4	19.6
1.85 M HCl 2 Hours	11.7	6.5	1.7	9.5	8.4	n.d.	n.d.	n.d.
1.85 M HCl 4 Hours	11.0	5.9	1.1	9.2	7.0	14.1	16.6	20.4
1.85 M HCl 8 Hours	10.8	6.4	1.2	9.3	6.3	14.2	16.8	20.6
1.85 M HCl 18 Hours	11.1	6.6	.7	8.4	6.0	13.6	16.8	20.1
0.85 M H ₂ SO ₄ 4 Hours	11.1	6.6	1.7	10.5	10.1	14.0	18.2	20.6
0.85 M H ₂ SO ₄ 8 Hours	10.6	6.6	2.0	9.9	9.1	14.0	17.9	20.2
0.85 M H ₂ SO ₄ 13 Hours	9.6	6.3	1.1	9.1	7.1	13.8	16.9	20.8
1.85 M H ₂ SO ₄ 8 Hours	11.0	6.6	1.3	9.8	7.1	14.7	18.3	21.2
Average Peak Areas For HCl Extractions ± Average Devia- tion	11.4 ± .40	6.5 ± .26	1.4 ± .38	9.3 ± .40	7.3 ± .90	14.2 ± .30	17.1 ± .46	20.5 ± .54
% Average Deviation for HCl Extractions	± 3.5%	± 4.0%	± 27%	± 4.3%	± 12.3%	± 2.1%	± 2.7%	± 2.6%
Average Peak Areas for HCl and H ₂ SO ₄ Extractions ± Aver- age Deviation	11.1 ± .35	6.5 ± .21	1.4 ± .34	9.5 ± .49	7.7 ± 1.04	14.2 ± .31	17.4 ± .58	20.6 ± .42
% Average Deviation for HCl and H ₂ SO ₄ Extractions	± 3.2%	± 3.2%	± 24%	± 5.2%	± 13.5%	± 2.2%	± 3.3%	± 2.0%

lack of knowledge in the field of carbohydrate geochemistry, a $\pm 10\%$ reproducibility is more than sufficient to discern general trends. Therefore, in the experiments with standard solutions an overall $\pm 10\%$ deviation is considered acceptable.

On the non-plateau regions of Figures 8 and 9 small changes in either hydrolysis time or acid concentration result in large variations in sugar yield. For example, Swain (1969) performs hydrolyses with 0.25 M H_2SO_4 (100°C) for 8-10 hours. Figure 10 compares a 0.35 M hydrolysis (8 hours) with a 1.85 M hydrolysis (8 hours) of the above Black Sea sample. The differences in yields and relative proportions of the sugars between the two methods are evident.

Several investigators (e.g., Degens and Reuter, 1964; and Swain, 1969) treated sediment with cold concentrated H_2SO_4 for 2-4 hours followed by dilution and further hydrolysis at 100°C. This method was tested on the above Black Sea sediment; the results are shown in Figure 8b. Glucose and mannose yields were increased by 20 and 10% respectively, however, comparable decreases in some of the other sugars occurred (especially the pentoses). This method has proven to be advantageous only when large quantities of cellulose are present in the sample, e.g., sewage sludge and land derived plant material. Polymers of lower molecular weight, such as amylose (starch cellulose), are completely hydrolyzed and recovered as glucose with the 1.8 N HCl method.

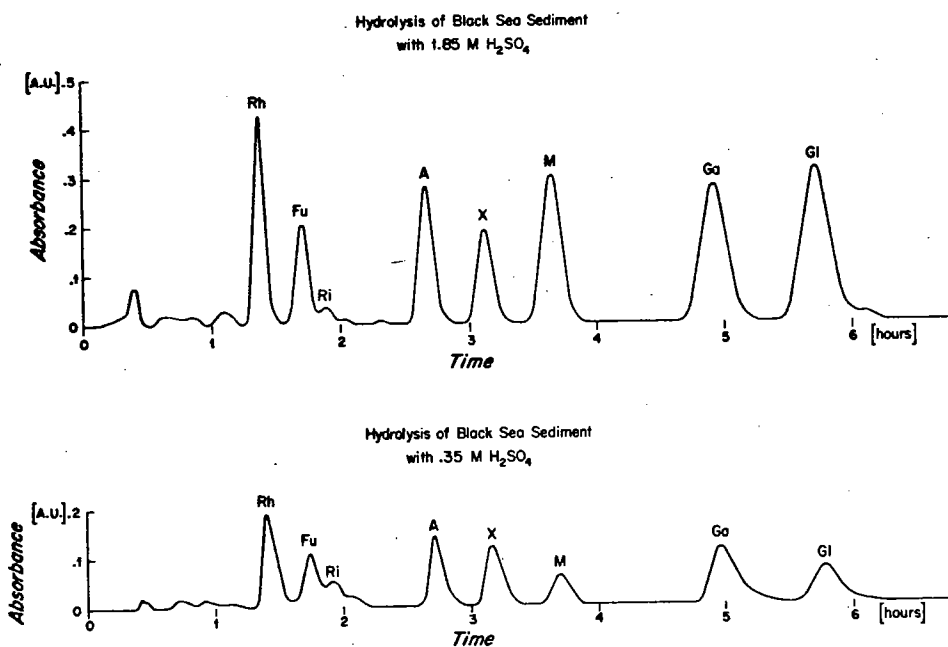

Figure 10

Extraction of carbohydrates from a Black Sea sediment sample with 1.85 M and 0.35 M H₂SO₄. A hydrolysis time of 8 hours was used for each test. These chromatograms show that not only is the total yield lower for the 0.35 M extraction, but the relative abundances are significantly different; mannose and glucose are especially reduced. Notation as in Figure 2.

In addition to determining the optimal hydrolysis parameters, the destructive effect of HCl and H_2SO_4 on the released monomeric sugars was also examined. Figure 6e depicts a chromatogram of a standard monosaccharide solution (9 sugars, 1 mg/ml each) after treatment under nitrogen with 1 M H_2SO_4 at 100°C for eight hours. Deoxyribose was destroyed 100%, ribose 30%, and xylose 15%. One M HCl gave the same results. Destruction of these sugars during hydrolysis of sediment may be less significant because: i) most sugars are initially either in polymeric form or are bound in humus-type residues and are released as monosaccharides gradually throughout the hydrolysis (Figures 8b, 9b), and ii) 2 to 3 hour hydrolysis times (for 1.8N HCl) are used with sediment as opposed to 8 hours used with the standard solution.

The destructive effects of acid hydrolysis were further examined by various spiking experiments. Argentine Basin sediment was spiked with a standard solution prior to hydrolysis. The results are presented in Table 1a (fucose, arabinose and galactose were not spiked in order to serve as checks against the untreated sediment). Again, ribose was destroyed to a large extent while the other sugars (including xylose) remained virtually unaffected within the experimental error ($\pm 10\%$). A fourfold change in the amount of sediment used (the amount of acid was constant) did not significantly alter these results.

The effect of $CaCO_3$ on acid hydrolysis yields was determined for Argentine Basin sediment which is free of $CaCO_3$. Table 3 reveals that the

TABLE 3

Spiking of Argentine Basin Sediment (2 gm) with CaCO_3 (0.6 gm);
 numbers represent peak areas in cm^2

A. HCl Hydrolysis

SUGARS	Rh	Fu	Ri	A	X	M	Ga	G1
Unspiked	6.6	7.8	2.7	7.0	6.8	10.9	14.0	14.8
CaCO_3 Spiked	7.0	8.4	3.6	7.2	7.9	11.6	16.7	17.2
% Difference	-6	-8	-33	-3	-16	-6	-19	-16

% average deviation 13%

B. Hydrolyzed EDTA xt.

Unspiked	5.0	5.6	2.8	3.8	5.9	5.2	9.0	7.2
CaCO_3 Spiked	4.8	5.6	2.4	3.5	4.7	4.5	8.4	7.8
% Difference	4	0	14	8	20	13	7	8

% average deviation 9%

CaCO₃-spiked sample (~30% by weight CaCO₃), when compared to the unspiked sample, shows no significant losses, but rather a slight gain is recorded (the gain is fairly close to the experimental error). The relatively large increase in ribose is further evidence that that sugar is particularly sensitive to changes in the extraction procedure. (The initial acid concentration in this experiment was adjusted to compensate for the CaCO₃.)

d. Deionization Techniques

(i) Precipitation of the acid: Swain (1969) eliminates H₂SO₄ by addition of barium carbonate to the reaction mixture; this procedure results in the precipitation barium sulfate. After neutralization the mixture is centrifuged and then desalted on ion-exchange resins. In the case of hydrochloric acid, silver carbonate may be substituted for barium carbonate.

Neutralization by precipitation is tedious, especially when large quantities of acid are involved. Furthermore, impurities in the salt will contaminate the sample.

(ii) Ion-exchange resins: Neutralization and desalting may be accomplished in one step with ion-exchange resins. The centrifuged or filtered sample is eluted with 250 ml of triple distilled water⁹ through a pair of columns containing excess cation exchange resin, AG 50-X8 in the hydrogen form (50-100 mesh), and excess anion exchange resin, AG 3-X4 in the formate form (20-50 mesh). Initially the anion exchange resin was used in the hydroxyl form; however, the high basicity of the resin caused total destruction of deoxyribose and partial destruction of ribose and xylose in a

⁹Distilled from permanganate.

solution of standard sugars (Mopper, 1970). Formate and bicarbonate forms of the resin caused no destruction.

The order of elution through the columns is important only when large quantities of salts are present in the sample. For example, when a standard sugar solution containing 0.5 M NaCl was first passed through the anion exchange resin (formate form), a 60% destruction of deoxyribose was observed (all other sugars were unaffected). The destruction is attributed to the formation of sodium formate, which in the dissociated form is moderately basic (a condition which is destructive to sugars). Passing the solution through the cation exchange resin first prevents the percolating solution from becoming basic.

e. Volume Reduction

After elution through the ion-exchange resins the volume of sample is gently reduced (~ 30 minutes, 60°C) from about 300 ml to about 5 ml on a rotary evaporator. This volume is then reduced further by blowing a stream of high purity nitrogen over the surface. Standard sugar solutions diluted to 250 ml are quantitatively recovered after volume reduction on a rotary evaporator at temperatures of 70 and 90°C .

Throughout the extraction procedure, the sample is never allowed to go to dryness, since this may cause the condensation of sugars and other organic compounds.

4. EXTRACTION OF CARBOHYDRATES FROM SEDIMENT: EDTA TREATMENT

Carbohydrates may be extracted from sediment by EDTA, either followed by acid hydrolysis (the hydrolyzed EDTA extract) or by itself (unhydrolyzed EDTA extract). A comparison of the hydrolyzed EDTA extract and the HCl extract for a Black Sea sediment is shown in Figure 11. The significance of the EDTA extracts will be discussed in the next chapter. Various questions arise concerning the use of EDTA in the extraction techniques. For example, what is the optimal time for treating the sediment with EDTA? What is the effect of temperature? Since metal ions displace hydrogen ions from EDTA, what pH variations occur? Do these variations in pH affect the yields? What is the effect of varying quantities of CaCO_3 ? Since EDTA is a weak acid ($\text{pK}_{a_1} = 2.18$), can it hydrolyze glycosidic bonds? Do varying sediment to EDTA ratios have any effect on the yields? How stable are sugars in the presence of EDTA?

In this section the results of various experiments are presented in order to answer the above questions.

a. Optimal Time of Extraction

In order to determine the optimal time of extraction, 2 g of Argentine Basin sediment (30 cm, CaCO_3 -free) were mixed with 1 g of EDTA and 10 ml of triple distilled H_2O and sealed in an ampoule under nitrogen. After heating for varying lengths of time at 100°C with constant stirring, the sample was centrifuged (10,000 rpm, 10 minutes), the liquid fraction was

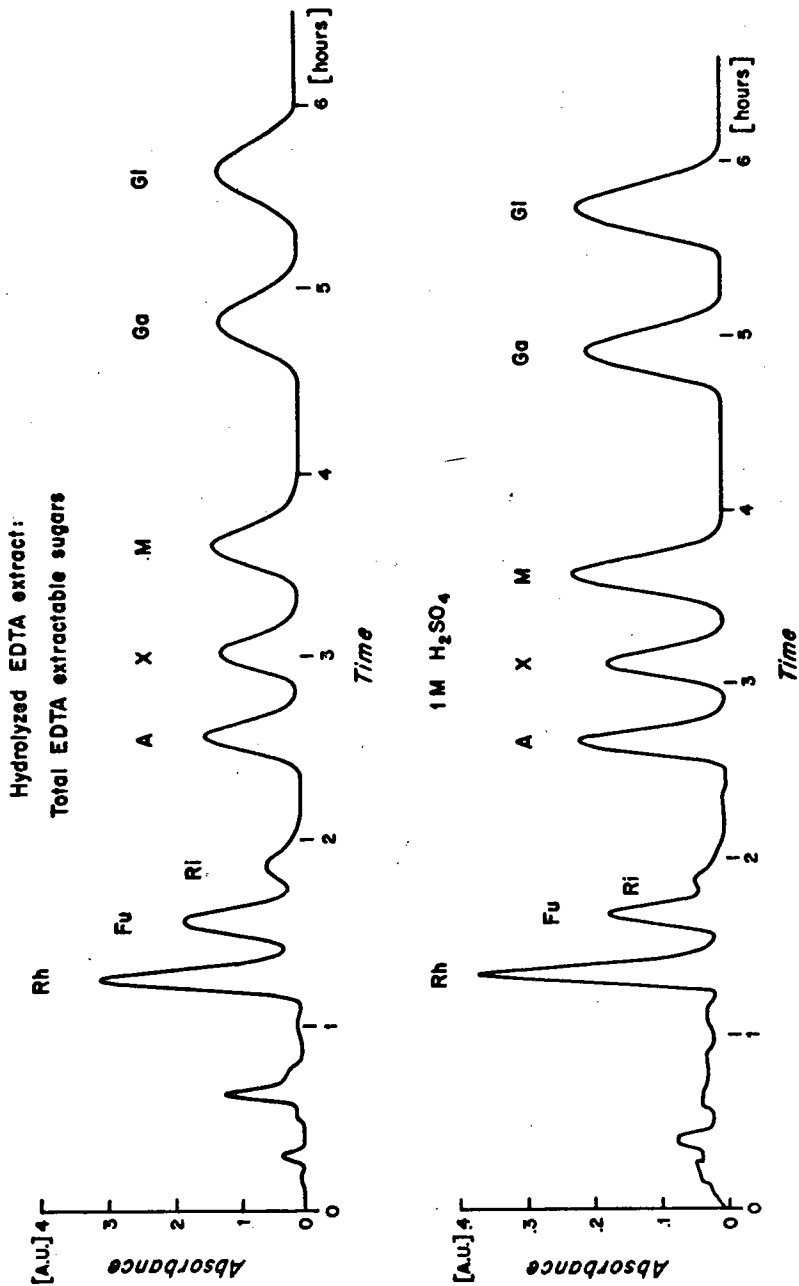

Figure 11

Comparison between total EDTA extracted carbohydrates and total acid extracted carbohydrates from a Black Sea sediment sample (1474K, 120-130_m). The hydrolyzed EDTA extract represents about 70% of the 'total' acid-extractable sugars. Notation as in Figure 2.

decanted and the mixture was again centrifuged. Concentrated HCl (36-38%) was added to the combined supernatant solutions to yield a final acid concentration of 1.8 N. The liquid was then hydrolyzed at 100°C for 3 hours followed by deionization and rotary evaporation. The results are presented in Figure 12a. With the exception of glucose, galactose, and mannose, sugars give a constant and maximum recovery after four hours of EDTA treatment. Glucose, galactose, and mannose continue to be extracted and these yields do not level off within the time span examined; however, this does not seriously affect the reproducibility. For example, a ± 2 hour deviation results in only a $\pm 5\%$ deviation in the amount of glucose released at 8 hours. An eight hour period is presently used for the EDTA treatment.

Similar trends and yields were obtained for a one-to-one mixture of EDTA and sediment. Thus, it appears that the sediment-EDTA ratio can be varied considerably without significant effects on the yields (this precludes the presence of CaCO_3 which reacts with EDTA). This constancy of sugar yields is probably related to the low solubility (0.5 ppt at 25°C) of EDTA. Thus regardless of the quantity of EDTA added, the concentration of EDTA will remain fairly constant.

The question arises: what is the effect of water alone? Figure 12b shows the time dependence of the yields of the hydrolyzed H_2O extract for the above sample. The figure shows that the recovery of 4 of 8 sugars do not level off within the time span examined; in general the trends are similar to those obtained for EDTA even though the yields of the hydrolyzed

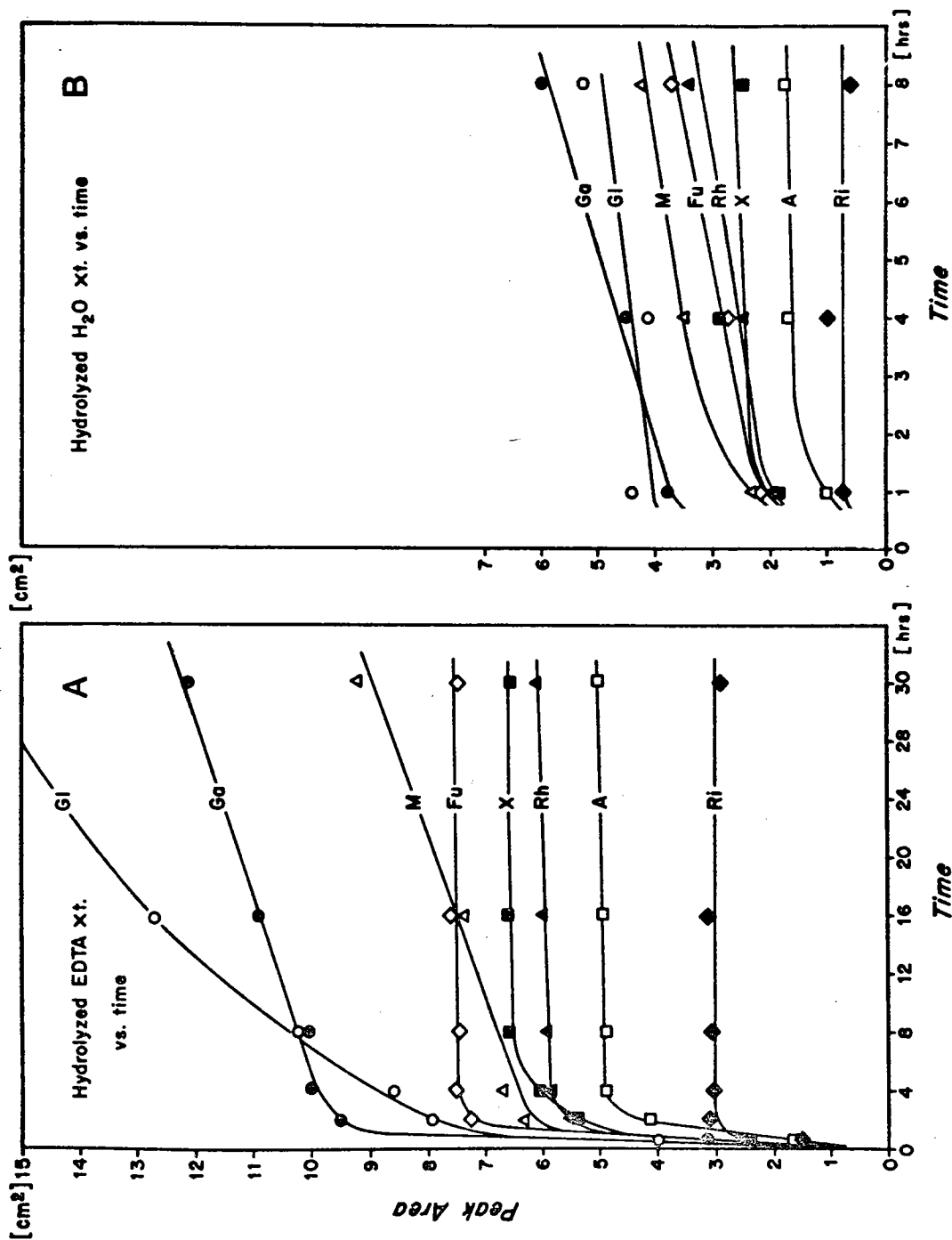

Figure 12

(a) Determination of the optimal EDTA extraction time. Equal aliquots (2 g) of an Argentine Basin sediment sample (st. 21, 30 cm) were extracted at 100°C with 1 g of EDTA for varying time intervals; the soluble fraction was then hydrolyzed. An extraction time of 8 hours was chosen.

(b) Determination of the optimal H₂O extraction time for the above Argentine Basin sediment. An extraction time of 8 hours at 100°C was chosen.

H₂O extract are less in comparison.

b. Temperature Effects

The effect of temperature on EDTA extraction efficiency was determined with Argentine Basin sediment (30 cm, CaCO₃-free). The same procedure as described in the previous section was employed, however, the time of EDTA treatment was fixed at eight hours and the temperature was varied between 40°C and 100°C. The results are plotted in Figure 13a. The results of the hydrolyzed H₂O extract for the same sediment are shown in Figure 13b. Temperature effects are considerably more pronounced for the EDTA extractions than for the H₂O extractions. This greater temperature dependence appears to be related to the increase in solubility of EDTA (and the decrease in pH) with temperature.

The present extraction temperature used is 100°C. At this temperature a $\pm 5^\circ\text{C}$ deviation will result in a 7% deviation in the quantity of glucose extracted.

c. Stability of Sugars in EDTA Solution

In one experiment a sediment sample (Argentine Basin 20-50 cm, CaCO₃ free) was spiked with a mixture of sugar standards prior to extraction with EDTA, followed by hydrolysis. Comparison of the spiked and unspiked samples is shown in Table 1b. Within the analytical error no destruction of the standards occurs.

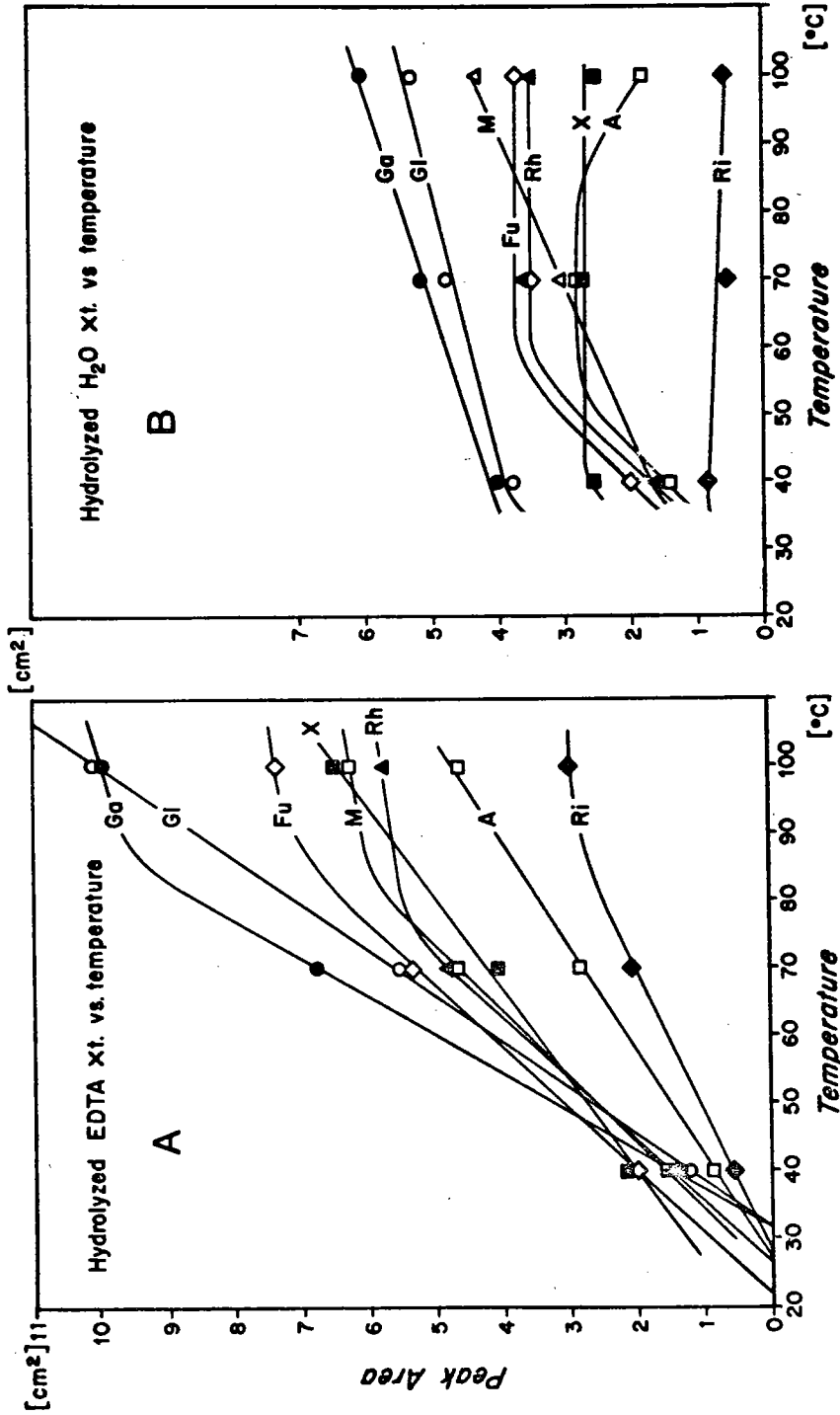

Figure 13

(a) and (b) Effects of temperature on the extraction efficiencies of EDTA and H₂O. The extraction time was 8 hours for each test. An extraction temperature of 100°C is used in the present thesis research.

Figure 12a indicates that sugars extracted from sediment by prolonged EDTA treatment are not significantly degraded; in fact either a levelling-off or an actual increase in recovery is observed. With the use of sugar standards, the stability of monosaccharides in the presence of EDTA (or Chelex 100, a chelating resin with EDTA-like functional groups) was determined. The results of these experiments are shown in Table 4. Within the analytical error ($\pm 10\%$) only the EDTA treatment, followed by acid hydrolysis, yielded results which indicated that some destruction had occurred ($\sim 30\%$ of xylose). This destruction, however, is primarily due to the acid treatment as explained in a previous section.

From these experiments it can be concluded that sugars are stable in the presence of EDTA (and Chelex 100) within the experimental parameters employed in the present research.

d. Hydrolysis Effects

EDTA is a weak acid ($\text{pK}_{a1} = 2.18$). Therefore, it seems possible that EDTA may promote the hydrolysis of glycosidic bonds; this might account for part or all the monosaccharides released in excess of the simple H_2O extract.

This hypothesis was tested with a disaccharide, lactose, and a polysaccharide, amylose. In one experiment 200 μg of lactose and 1 g of EDTA in 10 ml of H_2O were kept at 100°C for 8 hours. The quantity of glucose and galactose was then measured; approximately 9% of the disaccharide was hydrolyzed. This result suggests that, under the worst (and least

TABLE 4

Effects of EDTA and Chelex 100 on Sugar Standards
(peak areas in cm^2)

Sugar:	Rh	Fu	Ri	A	X	M	Ga	G1
untreated std.	14.1	15.9	15.0	16.5	16.0	15.4	12.6	16.1
std. A* + 10ml H_2O , 100°C, 8 hours, deionized	off- scale	16.9	15.5	16.7	18.6	15.4	12.5	15.9
std. A* + 6ml Chelex + 10ml H_2O , 100°C, 8 hours, deionized	off- scale	off- scale	15.6	17.3	16.4	17.2	13.8	17.9
std. B* + 1g EDTA + 10ml H_2O , 100°C, 8 hours, deionized	14.6	--	--	--	16.3	15.6	--	16.5
std. B* + 1g EDTA + 10 ml H_2O , 100°C, 8 hours followed by 1.8 N HCl, 100°C, 3 hours, deionized	13.6	--	--	--	10.9	14.6	--	19.6

* 500mg of each sugar was initially added; an equivalent of 25 mg of each sugar was analyzed.

probable) condition when all the carbohydrates in a sediment are present in the form of soluble disaccharides, ~9% will be hydrolyzed by EDTA.

In the second, more realistic experiment, 10 mg of amylose, a partially soluble polysaccharide, and 1 g of EDTA were mixed in 10 ml of H₂O and maintained at 100°C for 8 hours. An equivalent of 0.31 μ moles (56 μ g) of 'glucose' (e.g., assuming that amylose was totally converted to glucose) was injected and analyzed at high recorder sensitivity. No glucose was detected. Similar results were obtained when 0.3 g of CaCO₃ was added to the above system. Therefore, EDTA and its Ca salts exert no detectable hydrolysis effects on amylose.

It can be concluded from the above experiments that the extent of hydrolysis of sedimentary carbohydrates by EDTA is probably minor or negligible.

e. pH and CaCO₃ Effects

When EDTA forms chelates with metal ions, hydrogen ions are displaced from its structure and, therefore, a decrease in the pH is expected. However, since small quantities of sediment are employed (0.5-2.0 g) and since available metal ions constitute a minor fraction of sediment, one would expect that the pH effect might be negligible. Table 5 shows pH values of various EDTA extracts of sediment prior to hydrolysis. The pH values of the sediment extracts are similar to that of EDTA alone. Furthermore, the presence of varying quantities of CaCO₃ does not affect the pH because the hydrogen ions released are incorporated into carbonic

TABLE 5
pH Values of EDTA Extracts* of Sediment and Plankton

Sample	Weight of Sample (g)	CaCO ₃ content (%)	Quantity of EDTA used (g)	pH value of extract
Argentine Basin (100 cm)	2	0	1	4.4
N.Y. Bight (Buoy Station)	.2	.6	1	4.5
Lake Kivu (240 cm)	.4	15.2	1	4.4
Black Sea (120-130 cm)	1	27.0	2	4.3
Cariaco Trench (.15 cm)	.5	41.1	1.5	4.3
Oyster Pond (Surface)	.2	1.4	1	4.5
Walvis Bay (Surface sediment)	.5	.8	1	4.5
Distilled H ₂ O	--	--	1	2.7
Distilled H ₂ O	--	--	--	4.7
Plankton: Cariaco Trench	.05	2.1	1	2.7

* Sediment and EDTA and 10 ml H₂O; 100°C, 8 hrs; centrifuged

acid which rapidly decomposes into CO_2 and H_2O :

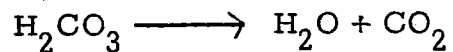
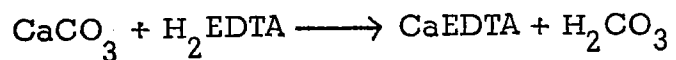

When CaCO_3 constitutes a large percentage of the sediment ($> 10\%$), excess EDTA is added to compensate for the above neutralization reaction. Table 3b shows the results of a spiking experiment where CaCO_3 was added to carbonate-free Argentine Basin sediment (20-50 cm) prior to EDTA treatment. The differences between the spiked and unspiked sample are generally within experimental error ($\pm 10\%$). Therefore, the presence of CaCO_3 in sediment apparently does not significantly alter the sugar yields.

5. GENERAL SAMPLE WORK-UP

A diagram of the sample work-up is presented in Figure 14. It must be emphasized that the ratio of sediment to the various reagents is largely determined by the organic and CaCO_3 contents of the sediment. Thus, a large percentage of CaCO_3 necessitates the addition of a sufficient quantity of acid (or EDTA) to compensate. As shown in this and previous sections, this excess reagent does not significantly affect the yields. The quantities of ion exchange resin varied in accordance to the quantity of sediment and reagents employed; basically, 30 ml of each resin (wet) is sufficient to de-ionize 10 ml of a 1.8 N NaCl solution. The actual amounts of sediment and reagents employed in the research are listed in Appendix II.

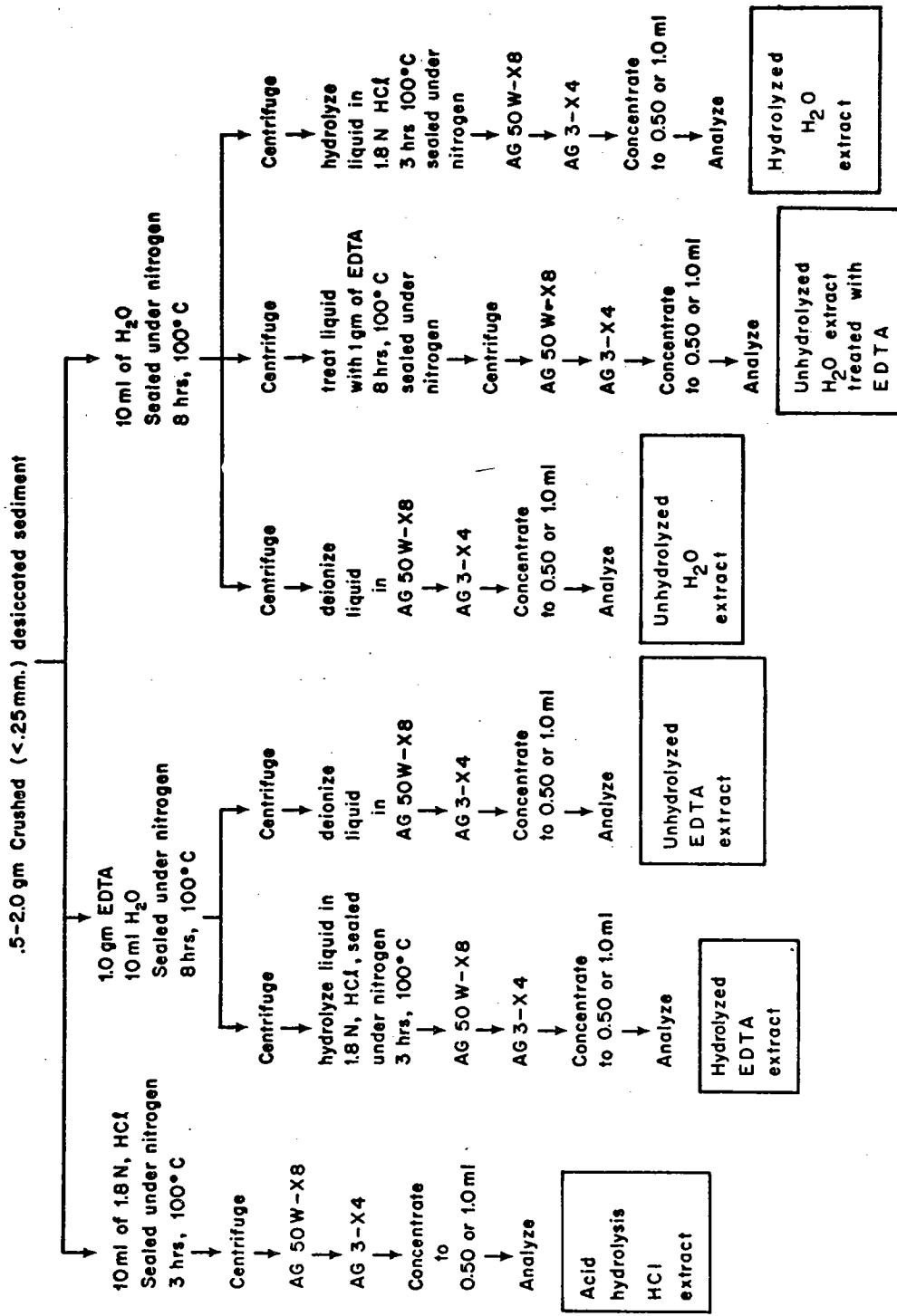

Figure 14

Schematic of carbohydrate extraction techniques. AG 50 W-X8 = cation exchange resin (H^+ form) and AG 3-X4 = anion exchange resin (formate form). The concentration step is done on a rotary evaporator.

CHAPTER III

SIGNIFICANCE OF THE EDTA EXTRACTS AND CARBOHYDRATE-METAL ION
INTERACTIONS IN SEDIMENT AND SOIL

In this chapter I present various lines of evidence to show that organic compounds (carbohydrates in particular) in soils and sediments are complexed with metals to a high degree.

1. SOIL SCIENCE LITERATURE: HUMIC AND FULVIC - METAL ION INTERACTIONS.

Since no literature exists on sediment organic matter - metal complexes, I review here soil literature which deals with the study of metal complexation of humic and fulvic substances. The soil results can probably be extended to marine sediments which have also been shown to contain humic and fulvic acids (e.g., Rashid and King, 1970). Reviews of the nature of humic and fulvic acids can be found elsewhere (e.g., Stevenson and Butler, 1969).

Complexation of metals by soil organic matter is probably responsible for the movement of these metals, especially iron, aluminum and manganese, from one horizon to another with their eventual precipitation (Wright and Schnitzer, 1963 and Schnitzer, 1971). Maksimov et al. (1972) demonstrated that humic acids extracted from soils and fossil organic deposits (coals) leach metals from various minerals and that the formation of soluble

Fe and Al complexes with aromatic hydroxy-acids facilitates their migration and redeposition.

Coleman et al. (1956), with the use of a titration method, studied the complexation capacity of peat; various amounts of Cu^{+2} were added to peat followed by titration of displaced H^+ with a base. A modified Bjerrum equation (Bjerrum, 1941; also see Martell and Calvin, 1952) was used to calculate the formation constants of the Cu^{+2} - peat complexes; the constants obtained were similar to those of polymeric acids. Beckwith (1959), also employing a titration technique, determined that 1 to 2 hydrogen ions were released per Cu^{+2} complexed. This investigator concluded that the binding sites were carboxyl and phenolic or alcoholic OH groups. The results of Beckwith (1959) were verified by Khanna and Stevenson (1961) who also employed potentiometric titration techniques; .6 to 1.5 hydrogen ions were released per Cu^{+2} ion bound to either soil fulvic acids or synthetic melanoidins (sugar and amine condensation products). During the formation of a one-to-one complex, two hydrogen ions are theoretically displaced from ligands (Martell and Calvin, 1952) by one Cu^{+2} ion. The low yields obtained by Khanna and Stevenson (1961) are explained as follows: (1) Cu^{+2} may be largely bound to functional groups (e.g., carboxyl groups) which are normally ionized in aqueous media (this explanation appears to violate electroneutrality); and (2) chelation sites may be partially masked by entrained metals.

Khanna and Stevenson (1961) also showed that the chelation ability of the transition metals varied but in all cases closely followed the Irving-Williams stability series. According to Irving and Williams (1948), the stability of divalent metal ion chelates, regardless of the chelating agent, follows the order: $\text{Pd} > \text{Cu} > \text{Ni} > \text{Co} > \text{Zn} > \text{Cd} > \text{Fe} > \text{Mn} > \text{Mg}$. Khanna and Stevenson (1961) used the fact that this series is followed by soil extraction results as evidence of some chelation despite the low hydrogen ion yields.

Schnitzer and Skinner (1965) employed methylation, acetylation, and esterification techniques, respectively, to selectively block alcoholic OH, phenolic OH and COOH groups on fulvic acid. The modified fulvic acids were then reacted with various metal ions. These authors concluded that the most active coordination sites involved: (1) the simultaneous reaction of metals with both phenolic hydroxyl and the more acidic of the carboxyl groups as shown below:

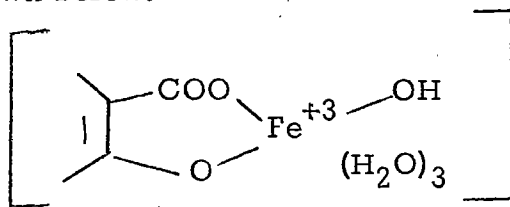

and (2) a minor reaction involving only the less acidic carboxyl groups. It was concluded that alcoholic OH groups participate in complexes to a negligible extent. Tan *et al.* (1971) by the use of IR studies on the interaction of Zn^{+2} with sewage sludge fulvic acid, concluded that aliphatic OH^- and COO^- groups are mainly responsible for the coordination. His fulvic acid samples showed IR characteristics similar to those of polysaccharides.

De Datta et al. (1967), by the use of IR methods, were able to isolate and characterize soil-polysaccharide - strontium 90, and yttrium 90 complexes. Wright and Schnitzer (1963) also studied soil organic extracts with IR techniques; they concluded that carboxyl, hydroxyl, and carbonyl groups are mainly responsible for complexation.¹⁰

Various methods have been employed to determine thermodynamic stability constants of metal complexes with soluble soil organic matter. These techniques involved partition of complexed and uncomplexed forms by solvent extraction (Hodgson et al., 1965, 1966); a resin exchange method (Miller and Ohlogge, 1958; ~~Randhawa and Broadbent~~, 1965; Schnitzer and Skinner, 1966, 1967; Schnitzer and Hansen, 1970; and Ardakani and Stevenson, 1972); and the method of continuous variations (Schnitzer and Hansen, 1970; and Schnitzer, 1971). The latter two techniques appear to give more reliable results, therefore, they are discussed in detail below.

The resin exchange method was first described by Schubert (1948) and was later discussed in detail by Martell and Calvin (1952). The equilibrium reaction for chelate or complex formation can be expressed as:

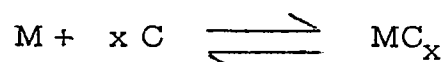

The formation constant is then:

$$K = \frac{(MC_x)}{(M) (C)^x}$$

¹⁰ Coordination of metals by nitrogen-containing functional groups is probably also significant, however, the IR methods of these investigators are insensitive to nitrogen-metal ion linkages.

where M = metal ion, C = complexing agent, and x = number of molecules.

Essentially the method depends on the fact that the quantity of cation bound to a definite amount of cation-exchange resin (MR) at equilibrium is proportional to the concentration of the cation in solution (M). λ_0 is defined as the distribution constant, (MR)/(M), for exchange in the absence of a chelating (or complexing) agent; λ is the distribution constant, (MR)/ $[(M) + (MC_x)]$, in the presence of a chelating agent. By rearranging the above terms K can be expressed as $[(\lambda_0/\lambda) - 1]/(C)^x$ or $\log [(\lambda_0/\lambda) - 1] = \log K + x \log (C)$. The slope and intercept of a plot of $\log [(\lambda_0/\lambda) - 1]$ vs $\log (C)$ are the values of x and $\log K$ respectively. The relationships hold only for soluble mononuclear complexes which do not bind to the resin. The cation concentration must be small compared to the complexing agent concentration. Temperature, volume, pH, and ionic strength must be held constant. Extrapolation of the formation constant, K, to zero ionic strength yields the thermodynamic constant. The results of various investigators are presented in Table 6. For all metal ions studied, the K values are several orders of magnitude less than those of EDTA (Table 7).

The restriction of the method to mononuclear complexes is not serious in acid solutions, since Geering and Hodgson (1969), Schnitzer and Hansen (1970), and Schnitzer (1971) demonstrated that at pH values < 4.5 and I = 0 - 0.1, molar divalent metal-fulvic acid ratios are about unity. In the pH range of 4.5 to 10, the ratios gradually increase from 1 to 2.

TABLE 6

Log of the Equilibrium Constants of Metal-Soil Organic Matter Complexes

Metal	Fulvic Acid*		Humic Acid**	
	pH 3	pH 5	pH 3.6	pH 7.0
Cu ⁺²	3.3	4.0	---	---
Co ⁺²	2.9	3.7	---	---
Ni ⁺²	3.1	4.2	---	---
Pb ⁺²	2.6	4.0	---	---
Mn ⁺²	2.5	3.7	---	---
Zn ⁺²	2.3	3.6	4.4	6.8 3.1-5.1(pH=6.5)
Fe ⁺³	6.1 (pH=2)	--	---	---
Al ⁺³	3.7 (pH=2)	--	---	---
Ca ⁺²	2.0 (pH=3.5)	3.3	---	---
Mg ⁺²	1.9	2.1	---	---

* after Schutzer and Skinner (1966, 1967); Schnitzer and Hansen (1970); and Schnitzer (1971)

** after Randhawa and Broadlent (1965) and Ardabani and Stevenson (1972)

TABLE 7
LOG OF THE EQUILIBRIUM CONSTANTS (K_1)* OF METAL CHELATOR COMPLEXES
 (Sillen and Martell, 1964)

Metal	EDTA	Glycine	Aspartic Acid	Gluconic Acid
Ba ²⁺	9.9	-	-	1.0
Ca ²⁺	10.6	1.4	1.6	1.2
Cu ²⁺	18.4	8.2	8.4	-
Fe ³⁺	25.0	10.0	11.4	5.5**
Mg ²⁺	8.7	3.0	2.4	.7
Pb ²⁺	18.2	5.5	-	2.6
Sr ²⁺	8.6	0.9	1.5	1.0
Zn ²⁺	16.6	5.0	5.8	1.7

$$*K_1 = \frac{[ML]}{[M][L]} [L]$$

$$**K_{Fe^{3+}} \text{ (gluconic acid)} = \frac{[FeL(OH)_3^-] [H^+]^3}{[Fe^{3+}] [L^-]}$$

Modifications of the resin exchange technique to include polynuclear complexes are described by Clark and Turner (1969), Ardakani and Stevenson (1972), and Zunino et al. (1972). The results obtained by these modifications, however, are not significantly different from those obtained by the simplified method of Schubert (1948).

The method of continuous variations was first described by Job (1928) and was later discussed in detail by Martell and Calvin (1952). Color is one of the more characteristic properties of chelate compounds; in fact, a change in color often accompanies a change in the extent of chelation. The method of Job depends on ~~variations of optical~~ densities of solutions containing different ratios of M (metal ion) and C (chelating agent) while keeping their total concentration constant. By imposing the condition $(M) + (C) = \text{constant}$, it can be shown that at the maximum chelate concentration (when $d(MC)/d(M) = 0$), $(Ke)/(M) = x$ (Martell and Calvin, 1952). Thus, the concentration of the chelate is highest when metal and chelating agent are reacted in the ratio they exist in the complex. A plot of optical density vs. solution composition yields a curve with a maximum at the composition of the complex. The restriction of mononuclear complexes also applies to this method.

Schnitzer and Hansen (1970) and Schnitzer (1971) compared this technique with the resin exchange method and found that the two methods yielded nearly identical stability constants for all metal - fulvic acid complexes examined.

For further information, general reviews of the complexing of metals by soil organic matter can be found elsewhere (Mortensen, 1963; Schnitzer, 1971).

2. METAL-CARBOHYDRATE COMPLEXES

The decay and metabolic degradation of cellular material results in the formation of heterogenous aggregates called humic and fulvic substances. In the previous section it is shown that functional groups in humic and fulvic substances of soil interact with metal ions to form stable complexes. It is also implicit that the degree of interaction is largely dependent on the total of functionality of the constituent molecules in the humic and fulvic substances. Rashid and King (1970) studied the functional groups and cation-exchange capacity of soil and sediment humic and fulvic acids. Comparison of the functional group and elemental compositions of soil and sediment organic extracts, as shown in Table 8, reveal many underlying similarities¹¹ which suggests that the results of soil researchers summarized in the previous section are largely applicable to sediment organic extracts.

Carbohydrates have a high degree of functionality and, therefore, may participate in complexes directly through coordination with metals and indirectly through both hydrogen bond formation and condensation with organic ligands. Several investigators have shown that reducing sugars and sugar alcohols form stable, soluble chelates with a wide variety of metals. For example, Bourne et al. (1959) show that soluble chelates form with Co^{+2} , Ti^{+3} , Zr^{+4} , Pb^{+2} , Sb^{+3} , Bi^{+3} , Fe^{+2} , Fe^{+3} , Co^{+2} , Ni^{+2} , Th^{+4} and VO_2^{+2} ; the sugars employed were d-glucitol, d-mannitol, dulcitol, pentaerythritol, d-glucose, and d-fructose. The formation of chelates

¹¹ I do not wish to imply that these extracts are exactly the same; e.g., sediment extracts have lower total acidity, lower concentration of phenolic

TABLE 8

A. COMPARISON OF MAJOR OXYGEN-CONTAINING FUNCTIONAL GROUPS

IN ORGANIC EXTRACTS OF SOILS AND SEDIMENTS

(After Rashid and King, 1970; and Wright and Schnitzer, 1963)

(meq/g, ash and moisture-free)

	Total acidity	COOH	Phenolic OH	Alcoholic OH	Total OH	C=O
Soil H.A.*	5.5	3.0	2.5	1.0	3.5	3.0
Soil F.A.	9.0	3.5	5.5	4.0	9.5	2.0
Sediment H.A.	3.0	2.5	1.0	1.5	2.5	4.0
Sediment F.A.	2.5	2.0	.5	N.D.**	N.D.	5.0

B. COMPARISON OF THE ELEMENTAL COMPOSITION OF ORGANIC EXTRACTS

OF SOILS AND SEDIMENTS

(After Rashid and King, 1970)

(% , ash and moisture-free)

	Ash	Carbon	Hydrogen	Nitrogen	Oxygen	C/N
Soil H.A.	6.1	52.3	5.6	3.7	38.4	14.1
Soil F.A.	8.5	49.2	3.2	1.7	45.9	28.9
Sediment H.A.	5.9	52.8	6.6	5.6	35.0	9.4
Sediment F.A.	10.6	46.2	6.6	4.5	42.7	10.3

* H.A. = humic acid; F.A. = fulvic acid.

** N.D. = not determined.

greatly inhibited the precipitation of metal hydroxides even under highly alkaline conditions (pH 12). Charley et al. (1963) presented spectral, titrimetric, and potentiometric evidence for complex formation. Their titrimetry revealed that 2 and 3 hydrogen ions were displaced from fructose by the formation of complexes with Fe^{+2} and Fe^{+3} respectively. These investigators showed that sugar-metal complexes are stable over wide ranges of pH, and metal ion and sugar concentrations. Using the elemental composition of the precipitated ferric-fructose complex, these authors deduced the following model:

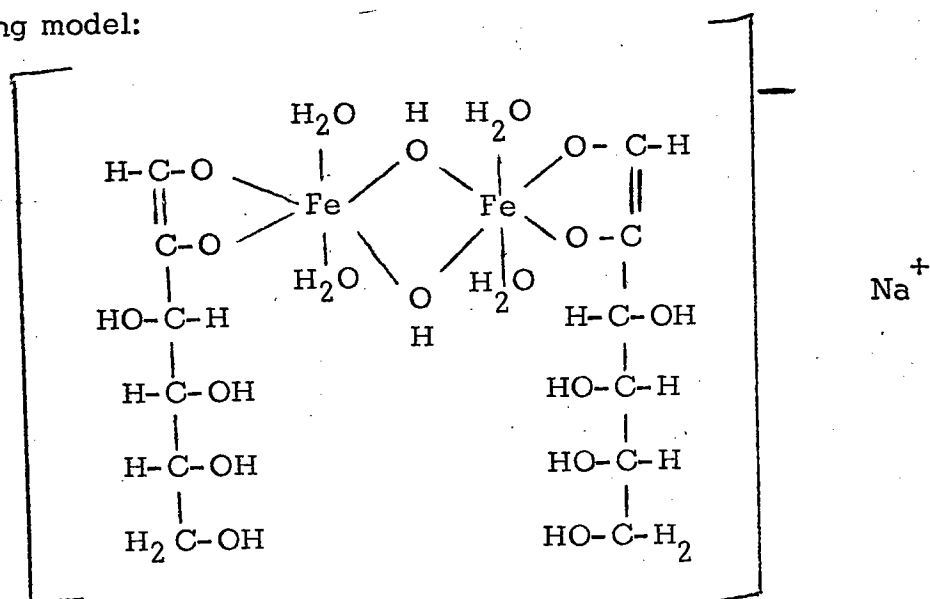

The presence of two iron atoms was determined by studies of electron spin and nuclear magnetic resonance.

Infrared studies of zinc complexes of sewage extracts indicated that in the lower molecular weight fulvic acid fraction polysaccharide-appearing substances accounted for most of the complexing activity (Tan et al., 1971). The following reaction was proposed:

OH groups, and lower C/N ratios than soil extracts.

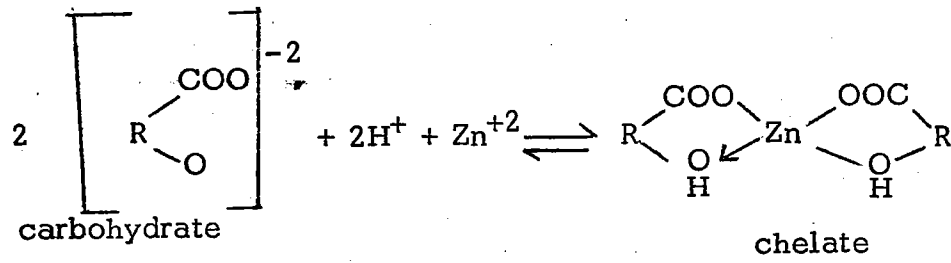

Infrared analyses have been used to characterize soil polysaccharide complexes of strontium 90 and yttrium 90 (De Datta et al., 1967).

3. CHEMISTRY OF EDTA

Aspects of the chemistry of EDTA relevant to EDTA - carbohydrate interactions (e.g., stability of sugars in the presence of EDTA, hydrolysis effects of EDTA, pH effects, CaCO_3 - sugar - EDTA interactions, effects of time and temperature on EDTA extraction, etc.) are presented in the previous chapter. In this section I discuss the general chemistry of EDTA.

Although EDTA is classified as a weak acid ($\text{pK}_a = 2.18$), its major characteristic is its ability to form extremely stable chelates with polyvalent metal ions.

An EDTA molecule coordinates metal ions through six possible sites (4 carboxyl and 2 amino):

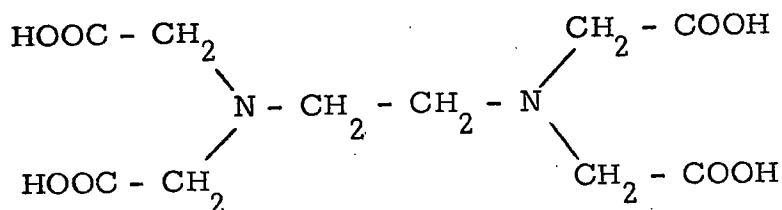

and, thereby, gives rise to a claw-like structure. In basic solutions the oxygens in the 4 carboxyl groups are identical because of resonance.

The structure of the EDTA-manganese complex (as derived from X-ray studies) is shown in Figure 15. The coordination results in formation of an ionic AB_7^{-2} sphere-like complex with a diameter of approximately 6 to 6.5 Å. EDTA complexes are able to form strong inter- and intramolecular hydrogen bridges. In the $(\text{EDTA} - \text{Mn})^{-2}$ complex all four coordinated oxygens possess a charge of $-1/2$; this residual charge increases the solubility of such

OH₂

Figure 15

Coordination complex of EDTA and Mn⁺² (after Richards *et al.*, 1964). The coordination AB₇ of the manganese: Mn (N₂O₅) is shown. The water molecule participating in this manganese complex is incorporated for reasons of coordination. The mean distances for the individual bond types are listed below:

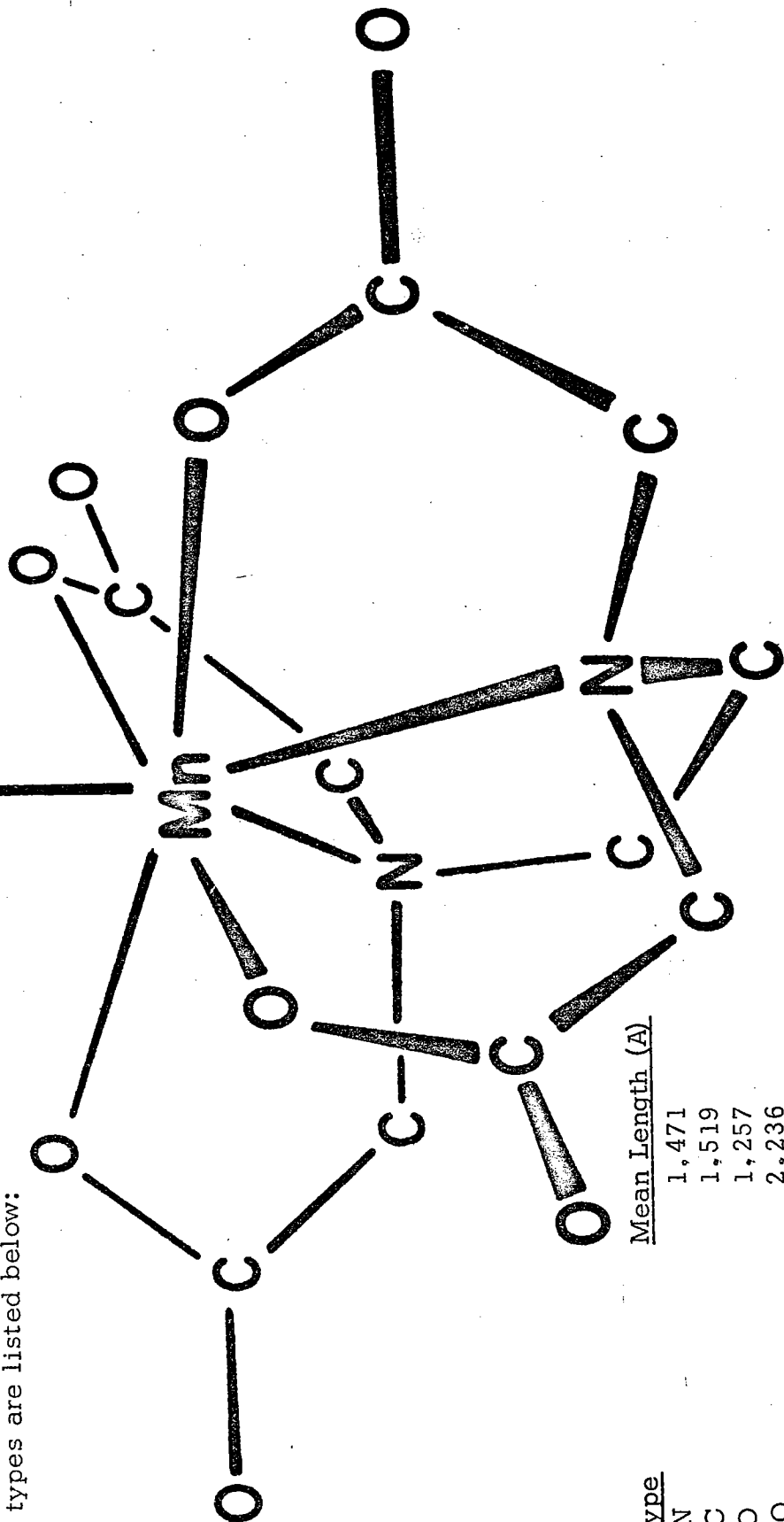

Bond Type	Mean Length (Å)
C-N	1,471
C-C	1,519
C-O	1,257
Mn ⁺² -O	2,236
Mn ⁺² -N	2,377
Mn ⁺² -OH ₂	2,155

complexes in polar solvents. Figure 16 represents the idealized structure of the $(\text{EDTA} - \text{Mn})^{-2}$ complex in solution. Comparing Figure 15 with Figure 16 shows the usefulness of constructing a coordination polyhedron for description of crystallo-chemical relationships exhibited by a complex. The asymmetry of the complex, which is difficult to represent in Figure 15, is easily seen in the coordination polyhedron (Figure 16).

Further details of the chemistry of EDTA can be found elsewhere (Martell and Calvin, 1952; Reilley et al., 1959; and Martell, 1971).

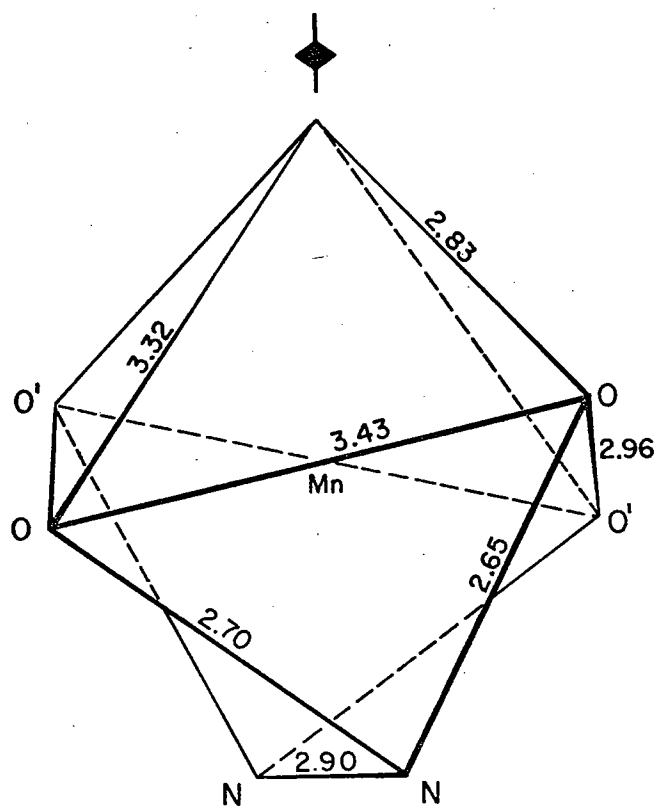

Mn-O=2.236 Å ; Mn-N=2.377 Å

Figure 16

The coordination polyhedron: AB₇ of the Mn(EDTA)⁻² complex as revealed by X-ray structure determinations. The numbers refer to the length of the edges in Å units (after Richards et al., 1964).

4. EXTRACTION OF METAL-BOUND CARBOHYDRATES FROM SEDIMENT

Bremner et al. (1946) extracted acid-washed soil with several strong chelating agents (e.g., pyrophosphate, sodium citrate, and sodium tartrate). They observed that the quantity of organic matter solubilized correlated with the quantity of metal extracted (exchangeable metal ions were removed by the preliminary acid washing). Dialysis of the extracts removed most of the metals and chelating agents leaving the solubilized organic matter still in solution; addition of manganese, copper, or iron to this solution induced precipitation. These authors found that these newly formed precipitates displayed the same solubility characteristics as shown by the compounds originally present in the soil. In this study it was concluded that some of the organic matter in soil exists as insoluble polyvalent metal ion-organic complexes, and that if the metal ions are removed from the complexes by a strong chelating agent, the organic matter becomes soluble.

This release of bound organic matter by chelating agents is known as the "chelate effect". This effect has been partially attributed to positive entropy changes in the solvent-solute system (Martell and Calvin, 1952). For example, since one EDTA molecule can displace as many as six ligand molecules from a complex, the additional freedom of movement (rotational, translational, etc.) of these displaced molecules increases the entropy of the system. The kinds and numbers of coordination bonds of the metal ion need not change during the displacement of the ligands.

Table 7 gives the stability constants for EDTA and sugar complexes with various metals. Comparison of the values indicates that the EDTA complexes are many orders of magnitude more stable than the sugar complexes, which suggests that sugar-metal associations can be effectively broken up by EDTA.

The question arises as to whether all the carbohydrates solubilized from sediment (or soil) by EDTA are originally metal-bound. Can EDTA, with its high mobility and claw-like structure, strip carbohydrates from humic and fulvic substances? If this effect is operative what fraction of the released carbohydrates is 'stripped' and what fraction is metal-bound?

In order to answer these questions I substituted Chelex 100, a strong chelating resin with EDTA-like functional groups, for EDTA in the hydrolyzed EDTA extraction of Argentine Basin sediment. The solid phase resin, Chelex 100, was chosen because of its lack of mobility; hence, the stripping effect mentioned above for EDTA does not apply to this system. The results of this experiment are presented in Table 9. It can be seen from this table that approximately 80% of the sugars solubilized by EDTA are also solubilized by Chelex 100. The remaining 20% probably represents the combined effects of stripping and minor hydrolysis (as mentioned in Chapter II). Therefore, I conclude that most of the carbohydrates solubilized from sediment by EDTA are originally bound by metals, though whether directly through coordination with metals or indirectly through either hydrogen bond formation or condensation with organic ligands has not been determined.

TABLE 9

CHELEX EXPERIMENT

(2 gm Argentine Basin sediment; numbers represent peak areas in cm^2)

SUGARS	Rh	Fu	Ri	A	X	M	Ga	Gl	Total
Hydrolyzed Chelex xt.	3.7	4.1	1.6	2.7	3.8	3.2	5.6	4.6	29.3
Hydrolyzed Resin	.5	.4	.1	.3	.7	.6	.7	1.7	5.0
Sum of Above	4.2	4.5	1.7	3.0	4.6	3.8	6.3	6.3	34.3
Hydrolyzed EDTA xt.	5.0	5.6	2.8	3.8	5.9	5.2	9.0	7.2	44.5
% of Hydro- lyzed EDTA xt. Released by Chelex Resin	84	80	61	79	78	73	70	88	77
Hydrolyzed H ₂ O xt.	1.8	2.2	.6	1.2	1.9	1.6	2.8	2.9	15.0
% of Hydrolyzed EDTA xt. Released by H ₂ O	36	39	21	32	32	31	31	40	34

In the following chapters the sugars observed in the unhydrolyzed EDTA extract will be equated with the metal-bound monosaccharides. Additional sugars observed in the hydrolyzed EDTA extract will be equated with the metal-bound polymers. Total sugars observed in the hydrolyzed EDTA extract will be identified with the total metal-bound carbohydrates (monomers and polymers).

EDTA is a sufficiently strong chelating agent to scavenge metals from carbohydrate-containing associations present in sediments and soils. It is conceivable, however, that some naturally occurring organic associations, such as quinone or sulfhydryl complexes, have a stronger affinity to metals than EDTA or other chelating agents. For example, EDTA extracts Cu from sewage sludges to a negligible extent compared to the EDTA recoveries of other transition metals (see discussion centered around Table 10, p. 104). Furthermore, since EDTA can effectively scavenge only polyvalent cations, natural complexes involving monovalent cations may be unaffected by the EDTA treatment (the abundance of monovalent cation complexes is probably low since these cations are readily displaced by polyvalent cations [Martell and Calvin, 1972]). Therefore, in the present study it is assumed that the EDTA extraction represents only a low first estimate of the metal-bound carbohydrates in sediment.

CHAPTER IV

PRESENTATION AND DISCUSSION OF DATA

1. PRESENTATION OF DATA

A general discussion of the sample material is presented in Appendices I and II. The data are presented in terms of mole % and $\mu\text{moles/g}$ dry weight in Tables III-1 to III-17 in Appendix III. In these tables the following notations are used:

Notation	Definition
'HCl'	HCl extract; considered to reflect total carbohydrates; referred to as 'total' in the following discussion.
'EDTA + HCl'	hydrolyzed EDTA extract; an estimate of the total metal-bound carbohydrates.
'EDTA'	unhydrolyzed EDTA extract; an estimate of the total metal-bound monosaccharides.
'H ₂ O'	unhydrolyzed H ₂ O extract; an estimate of the uncomplexed monosaccharides.

In the following section data for the reducing sugars only are discussed since the non-reducing sugars (e.g., sugar alcohols and acids) are not detected in the present analytical system.

2. DISCUSSION OF SAMPLE TYPES

a. Plankton

The carbohydrate compositions of plankton from various regions are shown in Tables III-2 and III-3 in Appendix III. The total carbohydrate content ranges from $< .5\%$ to 5% on a dry weight basis (100% would correspond to about 6000 umoles/g). The carbohydrate composition is variable. The general order of abundance in the HCl extracts is as follows: Ga > Gl > M > Ri > X > Fu \approx Rh > A (hexoses > pentoses). The function of galactose in plankton is unknown, however, the high variability of glucose is probably related to the biochemical function of this sugar since β -glucans are the commonest food storage products of algae (Meeuse, 1962; Handa and Yanagi, 1969).

The plankton from the Cariaco Trench and Oyster Pond were also partially extracted in the same manner as sediment: 'EDTA + HCl', 'EDTA', 'H₂O'. The Oyster Pond sample was treated in the wet state immediately after collection in order to minimize microbial degradation. The results are presented in Table III-1, III-2 and III-3. The unhydrolyzed H₂O extraction releases 4 to 5% of the 'total' while the unhydrolyzed EDTA extraction releases about 25% of the 'total' (it will be recalled from Chapter II that EDTA hydrolyzes $< 10\%$ of simple disaccharides). These analyzes suggest that some monosaccharides present in these plankton samples are metal-bound. ¹²

¹² It must be emphasized that hydrolysis effects of EDTA are probably more significant for plankton than for sediment. Sediments appear to be buffered (probably by inorganic phases) while plankton samples are not, as shown in

Approximately half of the 'total' is extracted by EDTA; about half of the EDTA extract is present as monomers (Table III-1, line a). EDTA-extracted pentoses (ribose, arabinose, and xylose) occur principally as monosaccharides (line a); EDTA-extracted hexoses (mannose, galactose, and fucose) occur principally as polysaccharides (line b). Line c (Table III-1) shows that hexoses are dominantly present as EDTA-inextractable sugars; deoxyhexoses (rhamnose and fucose) and pentoses are dominantly present as EDTA-extractable sugars (lines a + b).

The EDTA-insoluble sugars are probably present as long-chained structural polysaccharides (hemicellulose). It is of interest to note that Handa and Yanagi (1969) observed that the sugars usually found in such long-chained structural polysaccharides, xylose, mannose, galactose, and glucose, are the dominant sugars in the water-insoluble carbohydrate fraction of particulate organic matter at the surface of the ocean (0-50 m). From Table III-3 it can be calculated that mannose, galactose, and glucose constitute about 75% of EDTA-nonextracted residue. These sugars constitute only 65% of the 'total' (Table III-2).

The most significant findings are as follows: (1) sugars released by hydrolysis are similar in abundance to those found in sediment and aquatic plants by previous investigators (see Chapter I); (2) although a general order of abundance exists (hexoses > pentoses), no one sugar is present in overwhelming abundance; (3) a large percentage (40-60%) of the sugars released by acid hydrolysis are also extracted by EDTA and Table 5 (p. 73). EDTA extraction of plankton in a buffered system would eliminate interference of hydrolysis.

therefore this fraction appears to have been originally present as metal-bound monomers and polymers.

A review of the literature of marine algal carbohydrates is given by Percival (1968).

b. Organic Waste Products

(i) Sewage Sludge and Cow Manure: Since organic matter generally represents a small fraction of the total sediment (Bordovskiy, 1965) it is difficult to distinguish alterations that arise from biological degradation from those which may arise from non-biological diagenetic processes. Therefore, in order to clearly discern between these mechanisms, two systems in which microbial degradation is principally involved were studied: sewage sludge treatment and rumination in a cow. The data are presented in Tables III-1, III-4, and III-5 in Appendix III. The following trends are recognized:

1) The degree of metal association (hydrolyzed EDTA xt.) increases from 17% in the Deer Island primary sludge to about 77% in the Deer Island secondary sludge (Table III-1). This trend is not as pronounced in the Cranston data because cellulose determinations, which involve concentrated sulfuric acid treatment, were not performed.

2) Table III-1 shows that rhamnose, fucose, ribose, arabinose, and galactose are principally present as metal-bound sugars. Ribose and arabinose are dominantly metal-bound monomers. All the other metal-bound sugars are dominantly present as polymers. Line c (Table III-1) shows that glucose, xylose, and mannose are dominantly

present as EDTA-in extractable sugars. Table III-4 shows that arabinose is the dominant metal-bound monomer.

3) The unhydrolyzed water extractions release $<0.3\%$ of the 'total' while the unhydrolyzed EDTA extractions release about 5% in the primary sludge and about 15% in the secondary sludge (Table III-5).

4) Glucose shows the largest change in concentration after digestion. This trend is expected since cellulose is the major carbohydrate component of the primary sludge.

5) Cow manure is also the product of microbial digestion. Rumination in a cow can be considered analogous to a secondary sludge tank of a sewage treatment plant. The carbohydrate patterns of cow manure (Tables III-1, III-4, and III-5) are very similar to those of sewage sludge. For example, the material is highly metal-bound ($\sim 40\%$). Rhamnose, arabinose and galactose (ribose was not detected) are principally present as metal-bound species (Table III-1). Line c shows that glucose, xylose, and mannose are dominantly present as EDTA-in extractable sugars. Arabinose is the dominant metal-bound monomer (Table III-4).

The unhydrolyzed water extraction releases $<0.2\%$ of the 'total', while the unhydrolyzed EDTA extraction releases 8%. The relative abundance of glucose is reduced in comparison to other sugars in this sample and especially to the straw feed (not shown). The high abundance of xylose (Table III-5) is noteworthy and probably represents an undigested structural fraction of the straw.

From the above trends it can be concluded that microbial degradation

of organic matter, such as sewage sludge and straw, results in a large increase in the degree of metal association. This increase during microbial degradation of sewage strongly suggests that metal-bound carbohydrates are biologically inaccessible, even though they include a large fraction of easily degradable monosaccharides (up to 15% of 'total'). Such inaccessibility could be due simply to the low solution levels of free carbohydrates as shown by the unhydrolyzed water extraction, or could be due to inhibitory effects of the metal content of the bound carbohydrates (see discussion of Figures 25 and 26, p. 137).

Concurrent with an increase in metal association after degradation is a large decrease in carbohydrate carbon relative to total organic carbon which suggests that carbohydrates are utilized preferentially to other organic compounds (such as humic and fulvic acids). These trends are further discussed in Chapter V and Figure 27.

(ii) Heavy Metals Extracted from Sewage Sludge: Table 10 compares heavy metal analyses of EDTA extracts, and nitric acid extracts of sewage sludge. Metals constitute up to 10% of the total (dry weight); most of the metals appear to be almost totally extracted with EDTA. The metal recoveries for the EDTA extraction of the Deer Island secondary sludge are generally higher than for the Deer Island primary sludge. This trend indicates that digestion of sewage sludge renders metal ions more available for extraction with EDTA. The reason for this greater availability is

TABLE 10

METAL ANALYSES OF NITRIC ACID DIGESTED, AND EDTA EXTRACTED SEWAGE SLUDGES
($\mu\text{g/g}$ dry wt.)

Metal		Nitric Acid Digestion	EDTA* Extracted	%Extractable with EDTA
Lead	Cranston (s)***	365 **	345	95
	Deer Is (p)	868	975	112
	Deer Is (s)	722	750	104
Cadmium	Cranston (s)	12	5	42
	Deer Is (p)	36	28	78
	Deer Is (s)	55	55	100
Nickel	Cranston (s)	1,490	480	32
	Deer Is (p)	153	115	75
	Deer Is (s)	197	170	86
Chromium	Cranston (s)	280	103	37
	Deer Is (p)	895	900	101
	Deer Is (s)	1,376	1,675	123
Cobalt	Cranston (s)	19	---	---
	Deer Is (p)	11	---	---
	Deer Is (s)	12	---	---
Zinc	Cranston (s)	6,704	4,700	70
	Deer Is (p)	1,747	1,950	112
	Deer Is (s)	2,537	3,200	126
Copper	Cranston (s)	2,860	70	2
	Deer Is (p)	870	15	2
	Deer Is (s)	1,200	15	1

*Analysis of the EDTA reagent revealed only trace quantities of heavy metals. A water extraction (8 hrs, 100°C) of the Deer Is (s) sample released negligible amounts of heavy metals relative to the nitric acid digestion; e.g., 0.25% Cu, .70% Cd, .34% Zn, and 22% Ni. Metal analyses were run by Andy Jacobs.

** Metal analyses performed by Andy Jacobs by atomic absorption.

***s = secondary treated sludge
p = primary treated sludge

unknown, although it seems possible that the by-products of microbial degradation (e.g., humic and fulvic substances) may extract heavy metals from any inorganic phases present, as shown by Maksimov (1972) for soil humic acids.

The low Cu recovery of the EDTA extractions (Table 10) is not clearly understood. It is possible that the Cu is bound in in situ complexes which have a stronger affinity for that metal (e.g., sulfhydryl complexes) than EDTA. Further research is necessary to clarify this point.

Despite the high concentrations of potentially toxic heavy metals, they do not appear to interfere with microbial degradation. This suggests that these metals are bound with organic matter which in turn greatly reduces their activity (and hence their toxicity). Tan et al. (1971) measured a stability constant of 6.8 (at pH7) for zinc-sewage sludge extract complexes (see Table 7 for other stability constants).

c. New York Bight and Hudson Canyon: Oxic, Shallow Oceanic Shelf

The data is listed in Tables III-1, III-4 and III-5 in Appendix III. The sample labelled 'Buoy Station' was collected from the periphery of the sewage disposal area. Control samples, labelled Mid Gully and Deep Gully, were collected from the uncontaminated nearby Hudson Canyon. In almost all aspects the carbohydrate composition (Table III-4) of the sewage-containing sediment ('Buoy Station') is identical to that of the control sediments.¹³ For example the relative abundances in the HCl

¹³The carbohydrate content at 'Buoy Station' is the greatest found for any non-reducing sediment analyzed.

extracts are similar, although xylose and glucose may be slightly enriched in the sewage-containing sediment. The degree of metal binding is 60-70%. Hexoses are less bound than both deoxyhexoses and pentoses. The total sugar content relative to total organic carbon is about 5% for the 'Buoy Station' sample and 7-8% for the Hudson Canyon samples.

Thus, despite the differences in types (plankton debris vs. sewage sludge) and rates of organic input of these two shallow oxygenated marine environments, the end-product of biological degradation at these sediment-water interfaces is remarkably similar.

Furthermore, the results imply that in oxic environments the rate of benthic consumption is able to match even a large rate of organic input which further suggests that benthic consumption is limited by the rate of organic input. Thus, the high organic input rate at the 'Buoy Station' is matched by an equally high consumption rate (Smith *et al.*, 1973).

The treatment of raw sewage on land prior to shallow ocean dumping may be unnecessary because the rate of biological degradation of this substance at the sediment-water interface in shallow oxic environments may be comparable to and perhaps more efficient than primary and secondary sewage treatment. However, care should be taken to maintain a dumping rate which does not overload the environment since this may lead to the formation of anoxic conditions and death of benthic metazoan life (Mopper, 1971).

d. Argentine Basin: Oxic, Deep Oceanic Basin

The carbohydrate results of seven sediment samples from the Argentine Basin ranging in age from 0 to 90,000 years B.P. are shown in Tables III-1, III-8, and III-9. The compositions of various extracts are remarkably uniform for the time span sampled, although a diagenetic relationship between arabinose and xylose in the HCl xt. may exist: at the top of the core arabinose > xylose, in the middle arabinose ~ xylose, and at the bottom arabinose < xylose. Furthermore, an inverse relationship between glucose and ribose exists as shown in Figure 17. This inverse relationship may have resulted from changes in terrigenous and marine organic inputs.

Figure 23 (Chapter V) shows that terrigenous materials such as wood, peat, and sewage sludge are depleted in ribose and enriched in glucose; plankton material, on the other hand, is depleted in glucose and enriched in ribose.

The relative abundance of the sugars in the HCl extract of Argentine Basin sediment is: Ga > Gl > M > X ~ A > Rh ~ Fu > Ri; hexoses > pentoses (Table III-8). In the unhydrolyzed EDTA extract (EDTA extracted monomers; ~30% of the 'total') the reverse trend is observed: pentoses > hexoses, which suggests that hexoses are dominantly present as polysaccharides (an alternative explanation for this trend is that hexoses are preferentially adsorbed by clays; this possibility is discussed further in the next chapter). Fucose, ribose, arabinose, and xylose are dominantly present as metal-bound monomers (Table III-1). In the hydrolyzed EDTA extract the order of abundance is Ga > Gl > M ~ X ~ Fu > Rh > A > Ri. No one sugar in any of the

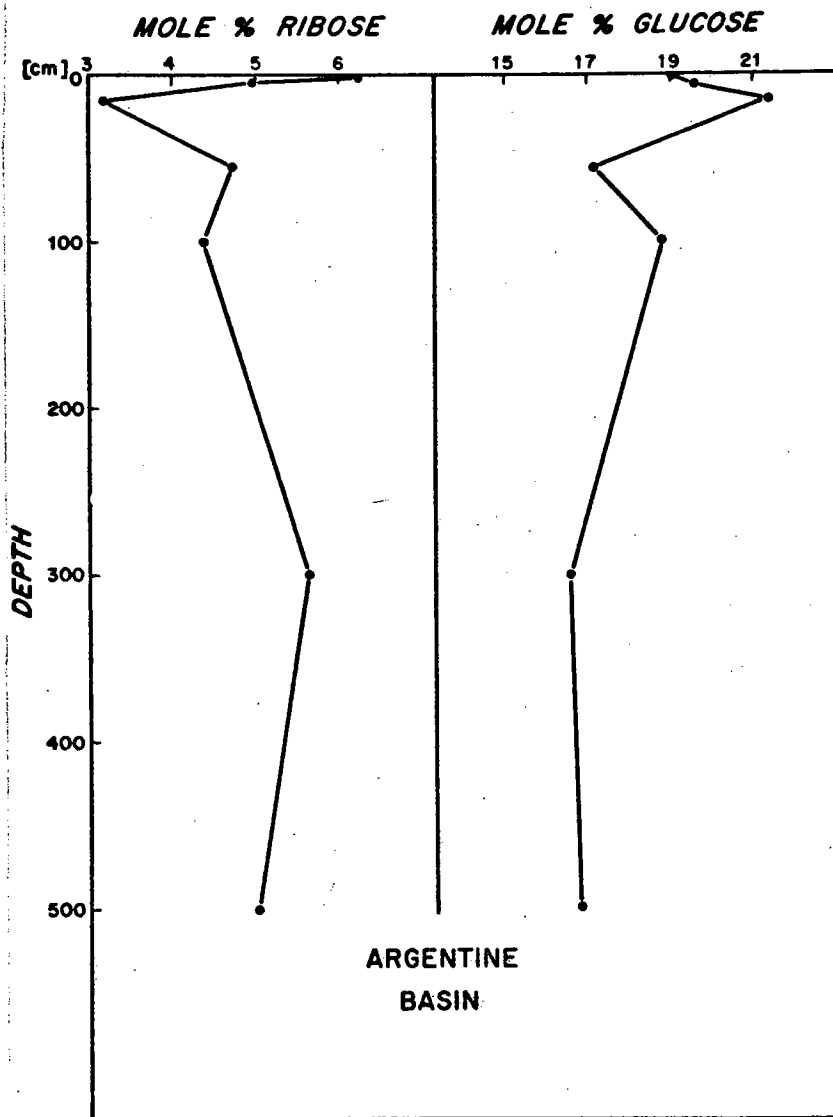

Figure 17

Ribose and glucose fluctuations in Argentine Basin sediments. The inverse relationship between these sugars is noteworthy. The glucose to ribose ratio in sediment may reflect relative changes in the terrigenous and marine organic inputs.

extracts is present in overwhelming abundance.

Comparison of the Argentine Basin data with the New York Bight and Hudson Canyon data reveals many underlying similarities. For example, the relative abundance of sugars in the extracts are almost identical. The degree of metal binding is 60-70%; about 25% of the 'total' is present as metal bound monosaccharides. Fucose, ribose, arabinose, and xylose are dominantly present as metal-bound monomers (Table III-1). These similarities suggest that in deep and shallow-sea oxygenated environments the end-product of biological degradation at the sediment-water interface is remarkably similar.

Figure 18 indicates that the total sugar content relative to the total organic carbon content¹⁴ is fairly uniform with depth with the exception of the surface samples, which show a slight enrichment. This enrichment may simply reflect time-dependent changes in benthic consumption and sedimentation rates. At high sedimentation rates carbohydrates may be buried at a faster rate than the biological consumption rate at the sediment-water interface. Thus, the enrichment of sugar at the surface may be the result of a recent change in the balance between consumption and sedimentation. Alternatively, the surface enrichment may reflect the breakdown period of readily consumable carbohydrates; the residue, which is presumably resistant to further consumption, is buried.

The results of section b for sewage sludge and cow manure strongly suggest that metal-bound organic matter is largely inert to and also

¹⁴

Which fluctuates; see Appendix Figure I-1.

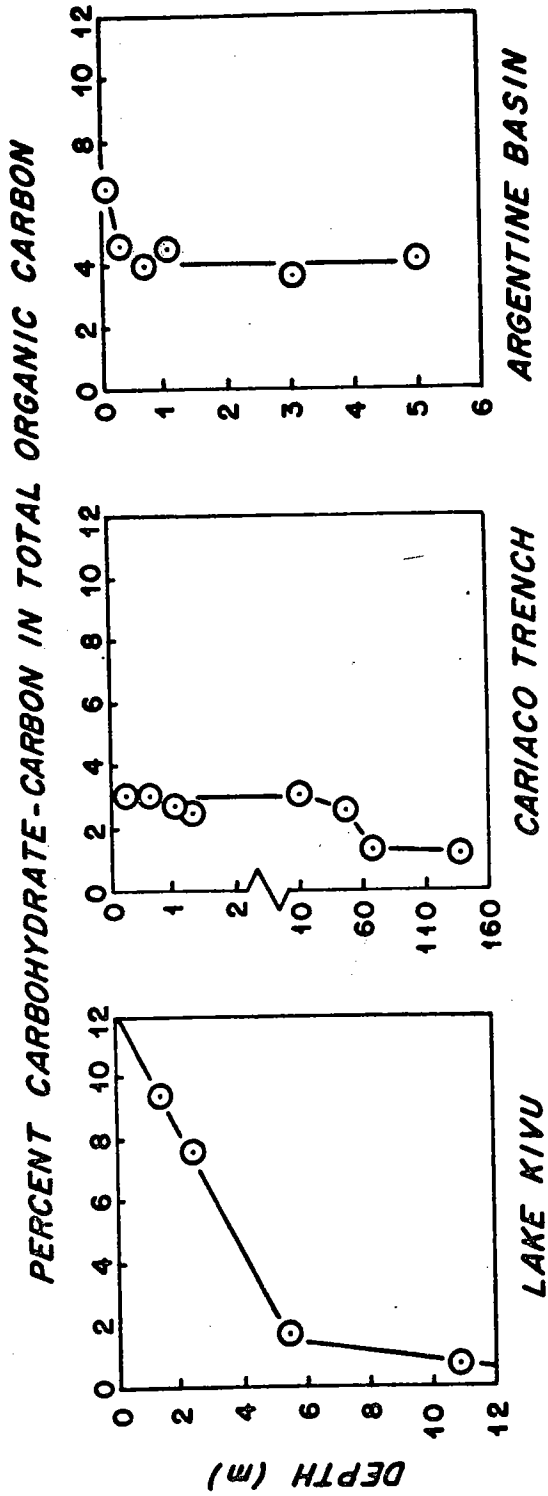

Figure 18

Depth changes in carbohydrate carbon relative to total organic carbon. Lake Kivu sediments show the largest change with depth. This change is probably the result of thermal degradation of sugars. The change in the Cariaco Trench sediments at 40-60 m is probably due to a change in the composition of the organic input. The reason for the change in the Argentine Basin surface sediments is presently unknown.

the residue of biological degradation. Along with an increase in metal binding with degradation, a decrease in sugar carbon (relative to total organic carbon) is observed. Thus, if either of the explanations mentioned in the previous paragraph is true, then one would expect to observe in the Argentine Basin an inverse relationship between the degree of metal association and the percent sugar carbon (in the total organic carbon). That is, as the sugar carbon (as % of total) decreases with depth (Figure 18), an increase in metal association is expected.

Figure 19 shows the temporal change of the hydrolyzed EDTA extraction (as % of the total). Although the average value is 63%, an actual decrease with depth of EDTA extracted sugars occurs. This unexpected decrease may be explained by any of the following:

- (1) the assumption that an inverse relationship exists between % sugar carbon and EDTA-extractable sugars only applies to recent degradation in surface sediments;
- (2) the enrichment in sugar carbon and EDTA-extractable sugars at the surface may reflect a recent change in nature of the organic input;
- (3) a diagenetic decrease in metal binding with depth occurred; metal ions may have been extracted from organic associations by diagenetic incorporation into clays; and
- (4) the diagenetic formation of H_2O and EDTA insoluble organic condensation products occurred; thus, although the degree of binding may not have decreased, the degree of intermolecular cross-linking

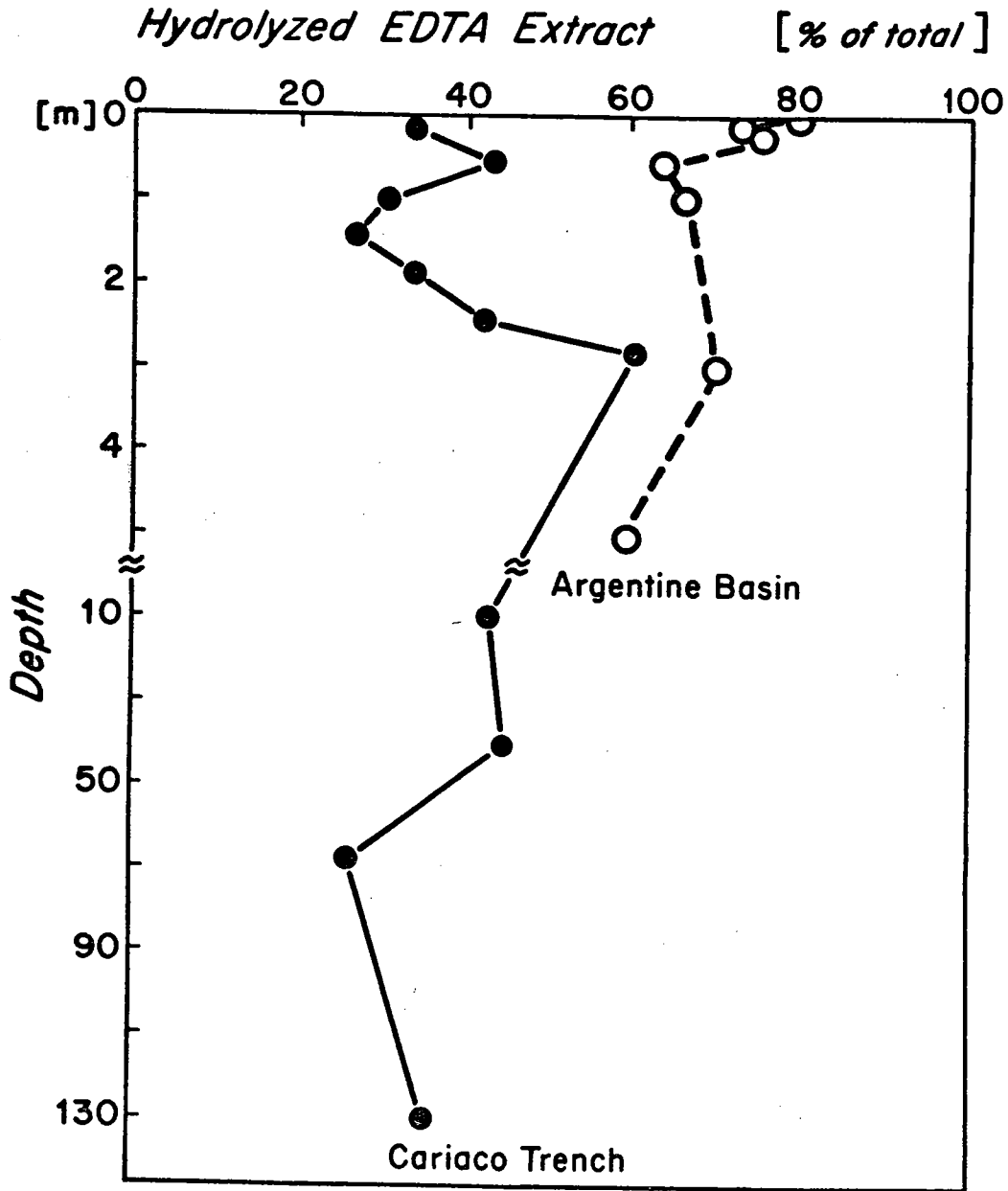

Figure 19

Comparison of the temporal changes in the degree of metal binding of carbohydrates in Cariaco Trench (reducing) and Argentine Basin (oxidizing). The peak at 2.65 m in the Cariaco Trench represents a band of oxic sediment. The degree of binding of carbohydrates in these sediments appears to be related to the Eh at the time of deposition.

between organic molecules may have increased (since EDTA is a weak acid, it is probably not capable of hydrolyzing these cross-linkages; see Chapter II).

At present, the data is insufficient to determine which ones (or one) of the above explanations are (is) correct.

e. Cariaco Trench: Anoxic Oceanic Trench

The carbohydrate results of twelve core samples from the reducing zone of the Cariaco Trench are listed in Tables III-1, III-6, and III-7. Omitting the wood sample (.64-.68 m), which is discussed below, the carbohydrate compositions for all three extracts (HCl, EDTA + HCl, and EDTA) are remarkably uniform down to 40 m even though the organic carbon content of the sediment drops from 6% to 1.9%. Figures 18 and 20 indicate that the total sugar concentration correlates well with the drop in organic carbon. These results suggest that the effects of diagenesis down to 40 m is either negligible (variations in the total carbon being due to variations of organic input rates) or remarkably nonselective.

The break in the sugar composition between 40 m and 67 m (Table III-6) along with the depletion of sugars relative to total organic carbon below 40 m (Figures 18 and 20) may be explained by one of the following: i) a sudden diagenetic change; ii) a change in the composition of the organic input; and iii) a change in the sediment surface microbial population. The inverse correlation in glucose and ribose shown in Figure 21 strongly suggests a change in the composition of the organic input occurred below

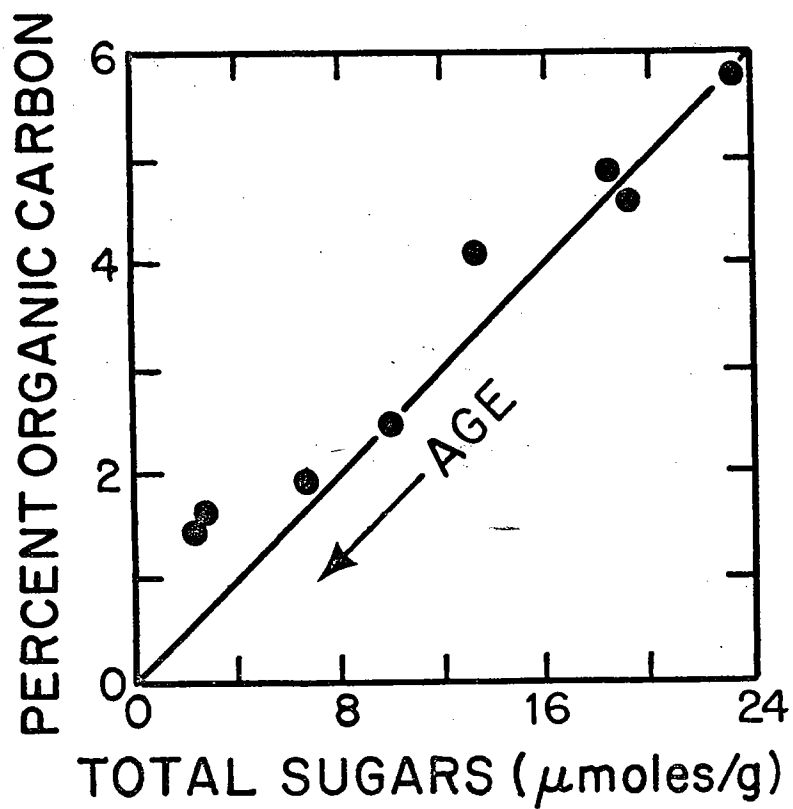

Figure 20

Relationship between total organic carbon and total sugars in Cariaco Trench sediments.

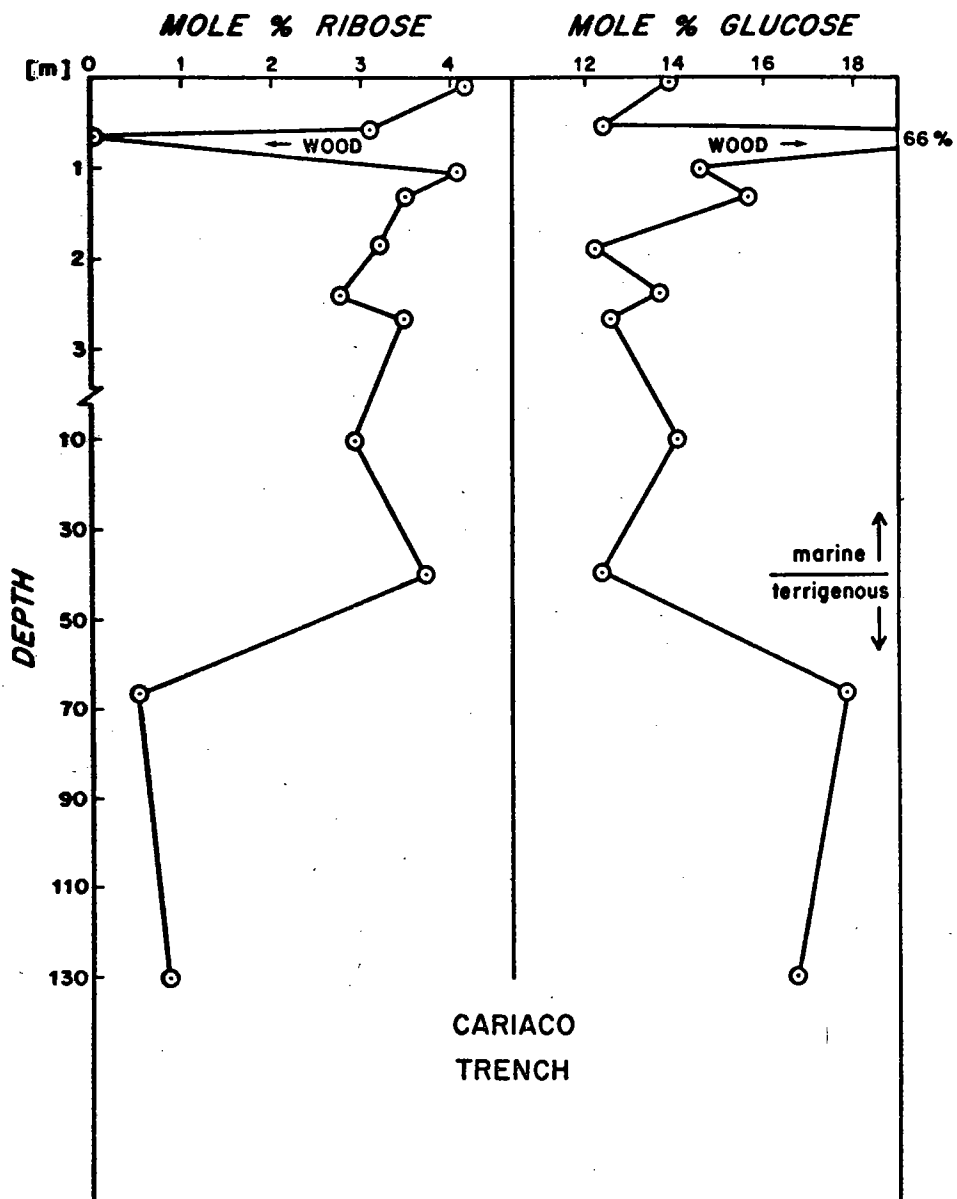

Figure 21

Ribose and glucose fluctuations in Cariaco Trench sediments. The inverse relationship between these sugars is striking. The lower sediments (> 40 m) probably reflect an increased terrigenous organic input.

40 m; these sediments appear to have a larger terrigenous input as evidenced by the increased glucose and decreased ribose contents.¹⁵

The relative abundance of the sugars in the HCl extract at all depths down to 40 m is invariant: Ga > M > Gl > X ~ Rh > Fu > A > Ri. The order of abundance is similar to that of the Argentine Basin from which it differs only in the inversion of mannose and glucose and the lower abundance of arabinose. The order of abundance is less similar to that of the plankton sample immediately above the trench. The orders of abundance within the unhydrolyzed and hydrolyzed EDTA extracts also more closely resemble that of the Argentine Basin than the Cariaco plankton. Fucose, ribose, arabinose, xylose, and galactose are the dominant metal-bound monomers (Table III-6).

The relative abundance in the HCl extract below 40 m is somewhat different from that of the overlying sediment: M > Ga > Gl > X > A > Rh > Fu > Ri, which again suggests a change in the source material and/or a change in the sediment surface microbial population.

The 2.65 m sample represents sediment deposited under oxidizing conditions as shown by metal analyses (Brian Price, pers. comm.). Relative abundances within the HCl extract and the hydrolyzed EDTA extract (Table III-6) are nearly identical to the overlying and underlying reducing sediment. If it is assumed that the carbohydrate composition of the organic input during this interval (reducing-oxidizing-reducing) remained fairly constant, then these results imply that a change in the sedimentary

¹⁵ Fluctuations in the glucose-ribose ratio appear to correlate with δC^{13}

environment from reducing to oxidizing, with the concomitant change in micro- and macrofauna, has little or no effect upon the composition of the sedimented carbohydrates.

The main difference in the carbohydrates extracts between the oxic and reducing zones lies in their degree of metal-binding. Figure 19 shows that for the reducing sediments the hydrolyzed EDTA extraction (metal-complexed monomers and polymers) releases about 40% of the 'total'; for the oxidizing band at 2.65 m the hydrolyzed EDTA extraction releases about 60%, a value which is similar to that of other oxidizing sediments, such as the Argentine Basin, New York Bight, and Hudson Canyon. These results first suggested that a correlation exists between the degree of metal-binding of sedimentary carbohydrates and the Eh at the sediment-water interface at the time of deposition.

The wood at .64-.68 cm is over 5000 years old, however, it is in remarkably good preservation; structural details such as intact cell walls still exist. However, this structure is actually very fragile and is easily destroyed in the dried specimen. An increase in the glucose yield by only 30 mole % after concentrated sulfuric acid treatment (Table III-6) suggests that the original cellulose has undergone some in situ hydrolysis (the Deer Island sewage sludge shows about a 60 mole % increase in glucose yield after sulfuric acid treatment, as shown in Table III-4).

In the wood sample, 14% of the 'total' is released by the unhydrolyzed EDTA extraction; hydrolysis of this extract released an additional 2% of the

fluctuations (Werner Deuser, pers. comm.).

'total'. Arabinose is the dominant metal-bound monomer (Table III-6). Although 16% of the wood carbohydrates can be brought into solution by removal of the metals by EDTA, no equivalent process appears to have occurred in situ; the carbohydrate composition of the surrounding sediment is completely unaffected by the presence of this carbohydrate-rich wood (Table III-6)¹⁶. These observations indicate that metal binding of soluble carbohydrates in the wood fixes that fraction in situ, thereby, inhibiting its diffusion. This conclusion contrasts with previous work by Prashnowsky et al. (1961) and Degens (1965) who hypothesized the chromatographic separation of carbohydrates along mineral surfaces.

f. Santa Barbara Basin: Anoxic Oceanic Basin

Two samples, dated at ~ 50 years and ~ 750 years B.P., are presented in Tables III-14 and III-15. The carbohydrate compositions of these samples are remarkably similar. In the HCl extracts the order of abundance is: Ga > Gl \approx M > X > Rh > Fu \approx A > Ri, which is almost identical to that obtained for the Cariaco Trench sediments. There does appear to be a slight enrichment of mannose and xylose and a slight depletion of arabinose with age. However, the data is insufficient to conclude whether these trends are diagenetic in origin or simply the result of secular changes in the composition of the input. As in the case of the Cariaco data, I lean to the latter.

The hydrolyzed EDTA extraction releases 43% of the 'total', a value which is similar to that of the reducing Cariaco Trench sediments; this

¹⁶The wood actually extended from .64 to 1.0 m, and presumably had a horizontal extension greater than the core diameter (~ 8 cm). The overlying and underlying sediment samples approached the wood within a centimeter.

result further suggests that carbohydrates have a lower degree of metal association in reducing sediments than in oxidizing sediments. The order of abundance within this extract is also similar to that of Cariaco Trench sediments (hexoses > pentoses).

The hydrolyzed H₂O extract represents the difference between the 'total' (H₂O insoluble + soluble extract) and the H₂O insoluble extract (2nd and 3rd lines in Tables III-14 and III-15).¹⁷ The hydrolyzed H₂O extract is similar in composition to the HCl extracts with minor exceptions: rhamnose and fucose are slightly enriched, while arabinose and glucose are slightly depleted.

Again, no one sugar in any of the above extracts is present in overwhelming abundance.

g. Walvis Bay: Anoxic, Shallow Oceanic Shelf

The carbohydrate data for the Walvis Bay surface sediment are shown in Tables III-1 and III-10. Walvis Bay sediments, like Cariaco Trench sediments, are also deposited under reducing conditions. Tables III-1 and III-10 show that the carbohydrate composition of surface sediment from these areas are remarkably similar with the exception of

¹⁷

The extraction techniques used for the Santa Barbara Basin sediments were different from those used for other sediments in this thesis because of an intercalibration study (see Chapter II). The H₂O insoluble + soluble extract = 'total'; the H₂O insoluble extract = hydrolysis of the H₂O insoluble sediment residue (sediments were washed 4 times with 25 ml of H₂O); and the hydrolyzed H₂O extract = hydrolysis of the combined washings.

mannose which is somewhat reduced in the Walvis Bay sediment. The hydrolyzed EDTA extraction releases 39% and 42% of the 'total' in these reducing sediments, respectively. The content of metal-bound monosaccharides is about 15% for both areas; fucose, ribose, arabinose, xylose, and galactose are again the dominant metal-bound monomers (Table III-10).

h. Black Sea: Restricted Inland Basin

The carbohydrate data of three samples, representing the three major sedimentary units of Black Sea core 1474 (see Appendix I for details), are presented in Tables III-1, III-12 and III-13. The deepest sample (120-130 cm, B.S. fresh) represents the freshwater, oxic period of the Black Sea. The order of abundance in the HCl extract (Table III-12) is: Ga > Gl > M > Rh > X~A > Fu > Ri. This order is similar to that of Argentine Basin and Cariaco sediments. Table III-1 indicates that about 65% of the 'total' sugars are metal-bound (EDTA + HCl), a value which compares well with sediment from other oxic environments (e.g., Argentine Basin, New York Bight); 14% of the 'total' is extracted as metal-bound monosaccharides. Ribose, fucose, rhamnose, arabinose, and xylose are predominantly metal-bound (Table III-1).

The 65-70 cm sample (B.S. transition) is from the organic-rich unit and represents the transition period from oxic fresh water to anoxic marine (4000-7000 B.P.). The hydrolyzed EDTA extraction releases 54% of the 'total', a value which is between oxic and anoxic sediments. The

high organic content of this sample (30-40% as shown in Figure I-1, Appendix I) suggests a terrigenous source. However, δC^{13} values of -24 to -26 for the organic matter are between that of marine and terrigenous organic matter (Deuser, 1972; Degens, 1969). Furthermore, a 'normal' order of sugar abundance in the HCl extract, $Ga \sim Gl > Rh > X > M \sim Fu > A > Ri$, and the low glucose concentration indicate an indigenous source for the organic matter.

Table 11 compares the Black Sea organic-rich sample with a marine peat deposit from George's Bank dated at about 10,000 years B.P. The contrast in sugar compositions is striking. Glucose accounts for only about 20-25% of the total sugars of the Black Sea sample (even after concentrated sulfuric acid treatment), while in the true peat deposit glucose represents 70% of the total sugars. Furthermore, the peat sample contains only traces of rhamnose, fucose and ribose while in the Black Sea sample these sugars constitute 25-30% of the total. The relatively high abundance of these latter sugars suggests an algal source for the organic matter in the Black Sea, which, in turn, implies that the primary marine productivity must have been extremely high in order to yield a 30-40% organic content in the sediment.

Electron micrographs of the organic matter in the organic-rich zone, Figures 22 a, b, c, and d, reveal intact membranes and cell wall fragments (Degens et al., 1970). No terrigenous plant detritus are observed. It is interesting to note that the organic matter shown in these figures did not

TABLE 11

COMPARISON OF THE CARBOHYDRATE COMPOSITION OF TRUE LAND-DERIVED
MARINE SEDIMENT AND POSSIBLE LAND-DERIVED SEDIMENT

Sample (Conc. H ₂ SO ₄ Treatment)	MOLE%										Total μ moles/g
	Rh	Fu	Ri	A	X	M	Ga	Gl			
Peat, George's Bank 10,000 years B.P.	3.1	1.0	0	2.3	7.3	8.4	8.9	68.9			354.8
Wood, Cariaco Trench 5000 years B.P.	3.9	.73	0	7.0	12.5	2.6	7.6	65.7			422.2
Black Sea Sapropel Layer 7000 years B.P.	14.9	8.9	4.5	6.1	12.4	9.2	19.5	24.5			246.1
Sample (1.8 N HCl Treatment)											
Peat, George's Bank 10,000 years B.P.	4.8	1.6	0	3.0	8.7	12.3	17.0	52.6			253.5
Wood, Cariaco Trench 5000 years B.P.	6.5	1.8	0	15.1	23.1	4.4	13.7	35.4			258.9
Black Sea Sapropel Layer 7000 years B.P.	15.1	10.9	5.5	8.9	12.6	10.0	18.3	18.8			250.8
Lake Kivu, Top Sediment 2000 years B.P.	5.3	3.0	.5	2.9	3.7	5.3	36.9	42.5			195.9

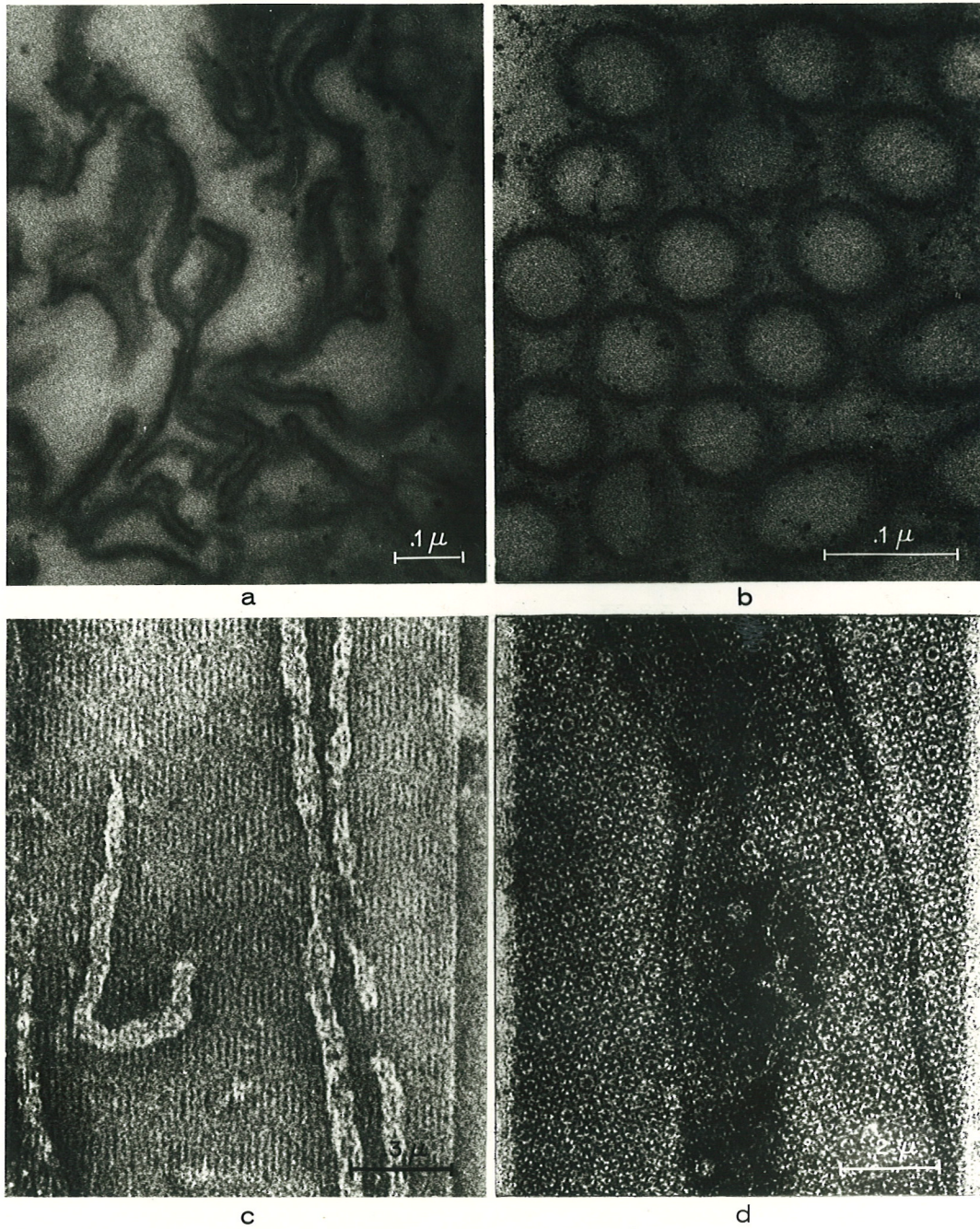

Figure 22. Caption on following page.

Figure 22

- (a) Branched, tubular membranes.
- (b) Large tubular membranes having a diameter of 700-800 Å and consisting of unit-membranes having a width of 80 Å.
- (c) Organic substance resembling a bacterial cell wall and showing a unique pattern of subunits which have a 40 Å periodicity.
- (d) Portion of an organic substance resembling a bacterial cell wall and consisting of a crystalline arrangement of subunits.

All four electron micrographs were taken of Black Sea sediment (core 1474K, 20-70 cm) in the sapropel layer. The samples did not need to be stained prior to microscopy because in situ heavy metal staining made visualization possible (after Degens et al., 1970).

need to be stained with a heavy metal (e.g., Os or Au) prior to microscopy. In situ heavy metal 'staining' made visualization possible (Degens et al., 1970). Thus, electron microscopy provides direct evidence for existence of some kind of metal-organic matter association in this sediment.

The third sample (15 cm, B.S. marine) represents the marine anoxic coccolith-rich zone. The hydrolyzed EDTA extract releases 40% of the 'total', a value which compares well with that of anoxic sediment from the Cariaco Trench and Walvis Bay. Rhamnose, fucose, arabinose, and galactose are dominantly metal-bound (Table III-1). The order of abundance within the HCl extract is somewhat different from that of other sediments: M > Ga > X > Gl > Ri > Fu > Rh ~ A. The particularly high abundance of ribose and xylose is noteworthy (Table III-12). This unusual distribution may be related to the dominant coccolith input which contrasts with the dominant algal input for sediments in other areas.

i. Oyster Pond: Anoxic Coastal Pond (Brackish)

Carbohydrate data for the Oyster Pond surface sample are shown in Tables III-1, III-10, and III-11. The order of abundance within the HCl extract is: Gl > Ga > M > X ~ Rh > A > Fu > Ri. The high abundance of glucose in this sample (Table III-10) relative to Oyster Pond plankton (III-2) and to sediment from other areas suggests the presence of a small terrigenous organic input. Considering that Oyster Pond is almost completely land-locked and is only 1100 m long and 300 m wide (Emery, 1969), this is a reasonable possibility.

The hydrolyzed EDTA extraction releases 44% of the 'total', a figure which is similar to that of other anoxic sediments. Metal-bound monomers account for 11% of the 'total' with arabinose, ribose, fucose, xylose, and rhamnose being principally metal-bound (Table III-1).

j. Lake Kivu: Anoxic Fresh Water Lake

The carbohydrate data of four Lake Kivu samples are listed in Tables III-1, III-10, and III-11. The relative abundance of sugars in the HCl extract is generally: Gl > Ga > M > X ~ Rh > Fu > A > Ri (hexoses > pentoses). Glucose exhibits the highest fluctuations which range from 43 mole % at the top to 25 mole % at the bottom of the core. The high glucose content of these sediments (especially the upper sample) may reflect a terrigenous organic input. Geochemical and paleontological evidence (Degens *et al.*, 1973) indicates that during certain periods the lake level rose dramatically due to high pluvial activity and discharges of hydrothermal waters. Flooding of nearshore swamps and increased run-off of humic materials from surrounding forests contributed substantially to the terrigenous organic input of the sediments, as reflected in the unusually high glucose content and low ribose content (Figure 23, Chapter V).

On the average, the hydrolyzed EDTA extract releases about 37% of the 'total', which is a value similar to that found for other anoxic sediments. The unhydrolyzed EDTA extraction releases 10-20% of the total; the monomers principally metal-bound in this extract are: rhamnose, fucose, arabinose, and xylose (Table III-1).

The high geothermal input in this area is expected to have profound effects on diagenetic patterns. Figure 18 demonstrates that total sugar carbon drops dramatically with depth relative to total organic carbon. The rapid decrease in sugar carbon stops at about 15,000 years B.P., after which further decrease occurs much more slowly. These trends are probably the result of the high temperatures ($>26^{\circ}\text{C}$). The initial rapid decrease may be due to preferential destruction of carbohydrates either by oxidation to CO_2 and H_2O or by conversion to furfural derivatives (the latter compounds did not show up in significant quantities in these chromatograms). The second and slower decrease might be due to formation of highly condensed, inextractable humic substances.

If these variations in sugar carbon are due instead to secular changes of the carbohydrate composition of the organic input, these changes must be more complicated than for other sediments studied. For example, if the terrigenous input increased gradually from 15,000 years B.P. to present, then the carbohydrate fraction of the total organic matter also increased gradually with time, thereby, giving rise to the trends in Figure 18. However, Table III-10 shows that the glucose contents of samples 530, 240, and 125 cm do not show a gradual increase, but rather a sharp increase between 240 and 125 cm. Furthermore, the percent sugar in the organic carbon for the 530 cm and 930 cm samples is significantly lower than that of sediment from all other areas sampled, which suggests that factors other than a change in composition of the input, such as geothermal energy, are operative.

CHAPTER V

1. DISCUSSION OF GENERAL TRENDS

Table 12 presents a summary of the mole % composition of HCl extracts of sediment and plankton from different environments. Generally, no one sugar in any of these extracts is present in an overwhelming concentration. The general order of abundance in sediment is: Ga > Gl > M > X \approx Rh > Fu > A > Ri; the order in plankton is: Ga > Gl > M > Ri > X > Fu \approx Rh > A. The orders of abundance are almost identical with the exception of ribose which shows a considerable depletion in sediment. This relative loss is probably attributable to the instability of ribose-containing organo-phosphate compounds, such as the adenosine phosphates and nucleic acids. Harvey (1960) observes that these compounds hydrolyze rapidly after cell lysis. Thus, the loss of ribose may have occurred in the water column shortly after the death of the organisms.

The above observations are consistent with the simple hypothesis that plankton is the source material for sedimentary carbohydrates. This hypothesis is further supported by stable carbon isotope analyses. In temperate regions marine plankton has a δC^{13} value of about -20 per mil (relative to PDB standard) with no apparent differences for zoo- and phytoplankton populations. Common land plants are 5 to 10 per mil lighter (Craig, 1953; Degens, 1969). In a number of studies it has been shown that the isotopic composition of organic matter in recent marine sediments

SUMMARY OF MOLE % COMPOSITION OF CARBOHYDRATES IN SEDIMENT AND PLANKTON
(HCT HYDROLYSIS)

TABLE 12

Sugar	Rh	Fu	Ri	A	X	M	Ga	G1
Argentine Basin <5 m (7)*	8.4	9.6	4.8	10.2	10.5	13.7	24.2	18.4
Bermuda Surface	10.7	9.8	4.1	8.9	12.6	16.8	23.8	13.1
N.Y. Bight Surface	9.1	8.1	1.6	8.6	12.9	15.1	21.5	23.1
Black Sea Marine. 15 cm	4.8	7.6	9.6	4.6	16.3	23.7	20.0	13.3
Black Sea Transition 65- 70 cm	15.1	10.9	5.5	8.9	12.6	10.0	18.3	18.8
Black Sea Fresh 1.30 cm	12.5	6.3	1.8	10.4	10.0	14.6	22.9	21.9
Cariaco Trench <40m (7)	11.0	9.2	3.5	5.5	9.7	19.3	28.0	13.6
Cariaco Trench 67-130m (2)	8.9	4.8	.7	9.9	12.3	23.9	23.2	17.2
Lake Kivu 2.0-9.3 m (3)	11.3	8.0	1.0	7.0	12.0	15.6	20.3	25.1
Oyster Pond Surface	11.1	6.8	.9	10.2	11.3	13.3	20.2	26.1
Malvis Bay, Surface	15.7	12.7	2.3	6.1	9.4	8.2	26.9	18.6
Santa Barbara Basin (2)	11.7	8.3	4.5	6.8	11.2	15.2	25.9	16.3
Average of above	10.4	8.1	3.1	7.7	11.1	15.0	24.0	20.6
Average of plankton (5)	5.4	6.7	10.0	2.7	8.2	14.5	29.5	22.9

* No. of samples represented

is identical to that of marine plankton (e.g. Sackett and Thompson, 1963; Hunt, 1968). In fact, local variations in δC^{13} values of plankton due to temperature and respiration effects are reflected in δC^{13} values of the underlying sediment. Only sediments deposited in river estuaries and close to shorelines reveal a terrigenous isotopic influence. The bulk of the organic debris contained in recent marine deposits seems to be derived from the local biomass.

The glucose and ribose concentrations in marine sediments also may be used to determine the relative terrigenous organic input of sediment. Table 11 and Figures 17, 21, and 23 reveal that terrigenous material contains a high percentage of glucose and a low percentage of ribose; in marine plankton the reverse is true. Thus, in sediment where glucose > galactose (or where glucose is > 20 mole % [Table 12]) and ribose is negligible, a major terrigenous fraction should be suspected.

Figure 23 shows that the relative abundances of glucose and ribose in most sediments are greatly reduced in comparison to terrigenous and marine sources respectively. The glucose-ribose relationship in sediment was not uncovered in the work of previous investigators in the field of carbohydrate geochemistry.

From the viewpoint of characterizing sedimentary environments the uniformity of the results in Table 12 is rather disappointing. Even when one examines sedimentary carbohydrates in terms of apparent metal ~~complexes~~^{bind-}tion (Tables 13 and 14), few underlying trends become apparent. A summary

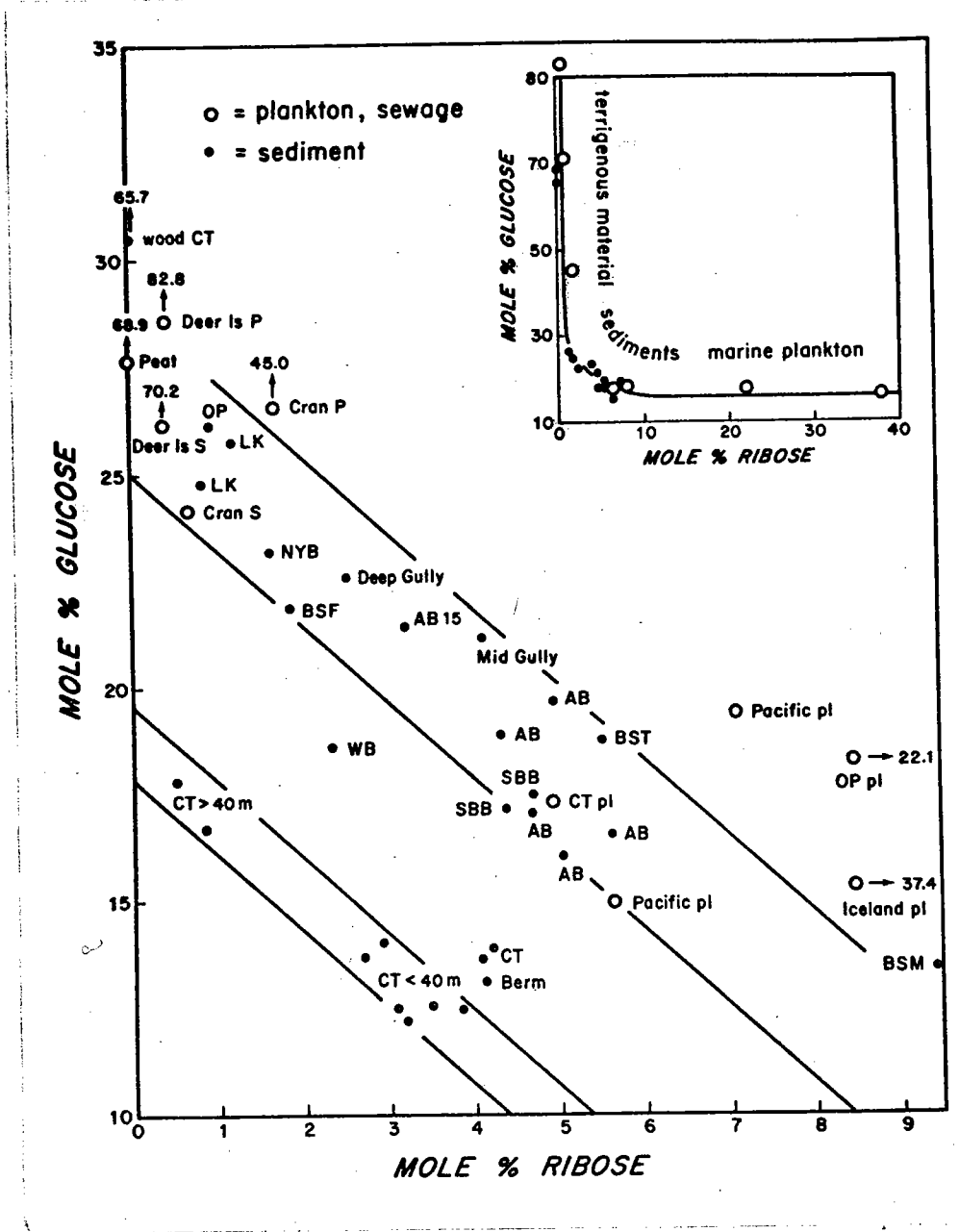

Figure 23

Relationship between glucose and ribose in samples studied in this thesis. An inverse relation exists: terrigenous material is enriched in glucose and depleted in ribose; marine plankton shows the reverse trend. The following notations are used: AB = Argentine Basin; CT = Cariaco Trench; NYB = New York Bight; OP = Oyster Pond; BSF, T, M = Black Sea fresh, transition, and marine; Berm = Bermuda; WB = Walvis Bay; SBB = Santa Barbara Basin; LK = Lake Kivu; Cran = Cranston sewage sludge; Deer Is = Deer Island sewage sludge; P = primary sludge; S = secondary sludge; and pl = plankton.

TABLE 13
SUMMARY OF MOLE % COMPOSITION OF CARBOHYDRATES IN SEDIMENTS
(HYDROLYZED EDTA EXTRACT)

Sugar:	Rh	Fu	Ri	A	X	M	Ga	G1
Argentine Basin <5m (7)	10.2	12.0	5.7	8.7	11.6	12.3	25.1	14.6
N.Y. Bight Buoy St. Surface	10.8	10.8	2.5	10.8	12.5	12.5	22.5	17.5
Hudson Canyon Deep Gully Surface	12.4	12.9	6.1	8.3	12.2	10.4	22.6	15.1
Black Sea Marine .15 cm	11.9	12.4	10.3	7.0	10.3	10.8	26.5	10.8
Black Sea Transition .65-.70 cm	19.3	13.0	5.5	6.8	14.0	8.7	15.6	17.0
Black Sea Fresh 1.3 cm	15.5	11.8	4.3	11.2	11.2	12.6	18.5	15.4
Cariaco Trench <40m (9)	13.2	13.9	5.6	7.4	11.3	10.9	26.8	11.3
Cariaco Trench 67-130m (2)	12.6	6.7	1.7	7.4	14.9	18.9	22.5	15.5
Lake Kivu 2.0-9.3m (3)	14.3	12.3	3.8	7.9	9.4	13.4	20.6	18.3
Oyster Pond, surface	13.6	10.3	2.0	15.0	12.5	9.5	21.4	15.6
Malvis Bay, surface	16.6	10.8	3.8	5.4	11.5	12.4	24.5	15.0
Santa Barbara Basin (50years)	13.3	12.5	7.8	7.8	14.1	10.2	24.2	10.2
Average of the above	13.6	11.6	4.9	8.6	12.1	11.9	22.6	14.7

TABLE 14

SUMMARY OF MOLE % COMPOSITION OF CARBOHYDRATES IN SEDIMENT
(UNHYDROLYZED EDTA EXTRACT)

Sugar:	Rh	Fu	Ri	A	X	M	Ga	GI
Argentine Basin <5 m (2)	8.7	15.8	15.3	14.3	15.3	4.8	17.4	8.4
N.Y. Bight Buoy St. Surface	6.7	14.4	9.2	21.5	21.5	3.5	17.8	5.4
Black Sea Marine 1.5 cm	3.5	14.2	33.3	9.6	19.3	1.5	17.5	1.2
Black Sea Transition .65-.70 cm	14.9	15.9	21.1	9.6	19.2	1.4	15.9	2.2
Black Sea Fresh 1.3 cm	12.3	11.5	10.0	24.6	10.8	3.4	18.5	5.5
Cariaco Trench <40m (5)	8.0	16.6	21.2	12.3	13.3	3.3	22.7	3.7
Cariaco Trench 67-130m (2)	9.3	11.8	3.7	9.9	24.7	11.1	19.8	11.0
Lake Kivu 2.0-9.3m	13.8	17.3	5.8	14.0	15.2	5.8	20.4	7.2
Oyster Pond Surface	9.9	15.6	5.2	32.3	16.2	2.7	15.0	3.7
Malvis Bay Surface	11.3	18.1	15.9	12.5	17.0	3.6	19.3	2.4
Average of the above	9.8	15.1	14.1	16.1	17.3	4.1	18.4	5.1

of the mole % composition of hydrolyzed EDTA extracts of sediment from different environments is presented in Table 13. The general order of abundance is: Ga > Gl > Rh > M ~ X ~ Fu > A > Ri. This order is similar to that observed for the HCl extract (Table 12) with a few differences. Mannose, glucose, and galactose decrease in relative abundance (galactose decreases by a lesser extent); this decrease is compensated for by a relative increase in the other sugars.

The general order of abundance in the unhydrolyzed EDTA extract (Table 14) is: Ga > X ~ A ~ Fu ~ Ri > Rh > Gl ~ M. Comparison of this extract with the HCl extract reveals that the relative compositional changes are similar to but more exaggerated than those found for the hydrolyzed EDTA extract (discussed above).

Figure 24 illustrates the compositional changes in the averages of the different extracts from Tables 12, 13, and 14. With each extraction (HCl, HCl + EDTA, EDTA) the compositions generally become progressively different from that of plankton (presumably the source of sedimentary carbohydrates). The hexoses, glucose, mannose, and galactose, decrease in relative abundances, with galactose decreasing to a lesser extent. These decreases appear to be compensated for by increases in the pentoses and deoxyhexoses. The initially high value of ribose in plankton relative to sediments was explained previously. The reason for the drop in rhamnose between the EDTA + HCl and EDTA extracts is presently unclear. The trends mentioned above appear to hold for nearly every sediment sample analyzed.

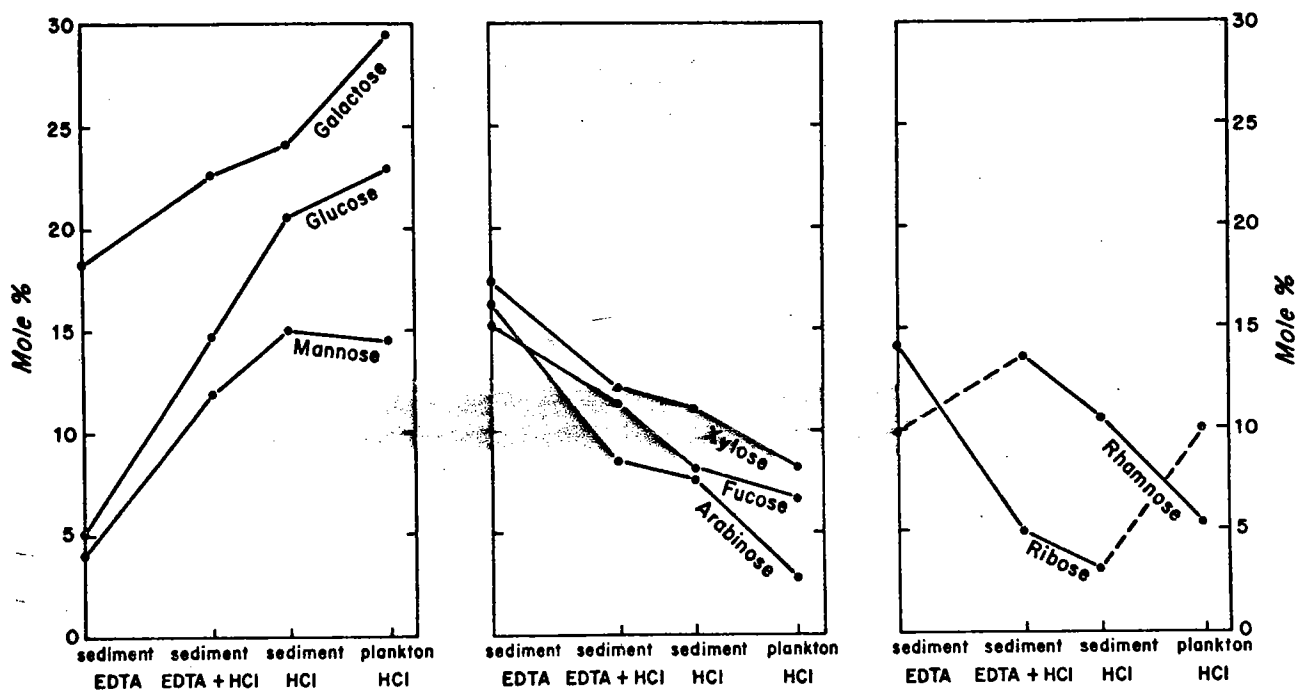

Figure 24

Relationships among the relative sugar compositions in different sediment and plankton extracts; data was drawn from the averages in Tables 12, 13, and 14 in the text; these relations hold for individual samples as well as the averages; EDTA = unhydrolyzed EDTA extract, EDTA + HCl = hydrolyzed EDTA extract, and HCl = 'total' hydrolyzable carbohydrates.

The trends in Figure 24 might be explained in terms of differences in metal ion affinities; thus pentoses and deoxyhexoses would have a greater affinity than hexoses for metals. However, in light of the fact that hexoses have more functional groups than the other sugars, this explanation is unlikely.

Alternatively, it might be argued that hexoses are more strongly bound to mineral phases than are pentoses. The validity of this argument was tested with the following experiment: 0.1 ml of a solution of nine sugar standards (1000 $\mu\text{g}/\text{ml}$ of each sugar) was mixed with 10 ml H_2O and 1 g of organic-free kaolinite; after standing 20 hours in a desiccator at 25°C the sugars were extracted from the mixture with 20 ml of H_2O and analyzed.

The results, which are shown in Figure 6 a, b (Chapter II), indicate that within the analytical error ($\pm 10\%$) only deoxyribose is absorbed by the clay (or eliminated by condensation reactions). From this experiment I conclude that preferential absorption of sugars by mineral phases in sediment is probably negligible.

The reasons for the compositional changes shown in Figure 24 may be related to differences in the molecular weight distribution of the carbohydrates. For example, it seems probable that mannose, glucose, and galactose are more associated with high molecular weight water-insoluble polysaccharides than other sugars. Thus, after EDTA treatment these polysaccharides are centrifuged down along with the sediment residue. Table III-1 shows that glucose, galactose, and mannose are indeed dominantly

associated with the EDTA-insoluble residue.

Since the composition of the unhydrolyzed EDTA extract is furthest removed from that of plankton (Figure 24), the size of this extract (relative to 'total') is probably related to the degree of degradation in sediments. Thus, one would expect to find that metal-bound monomers represent a larger fraction in oxic sediments than in reducing sediments. Figure 25, which is drawn from data in Table III-1, shows that for total sugars in oxic sediments the concentration of EDTA extracted monomers is indeed greater than the concentration of EDTA extracted polymers; in reducing sediment the reverse trend holds. Furthermore, Figure 25 shows that reducing sediments cluster closer to the origins of the graphs than oxic sediments, which indicates that the concentrations of sugars extracted with EDTA for reducing sediments are lower than that for oxic sediments.

In Figure 26, which is also drawn from data in Table III-1, the percent of the 'total' released by the hydrolyzed EDTA extraction is plotted against the different sample types. EDTA extracts 60-70% of the 'total' for oxidizing sediments and 35-45% of the 'total' for reducing sediments. These trends again suggest that carbohydrates are considerably more metal bound in oxidizing sediments than in reducing sediments.

The difference in metal binding of carbohydrates between oxidizing and reducing environments may be explained in terms of differences in:

(i) degree of biological activity, and (ii) degree of metal ion availability.

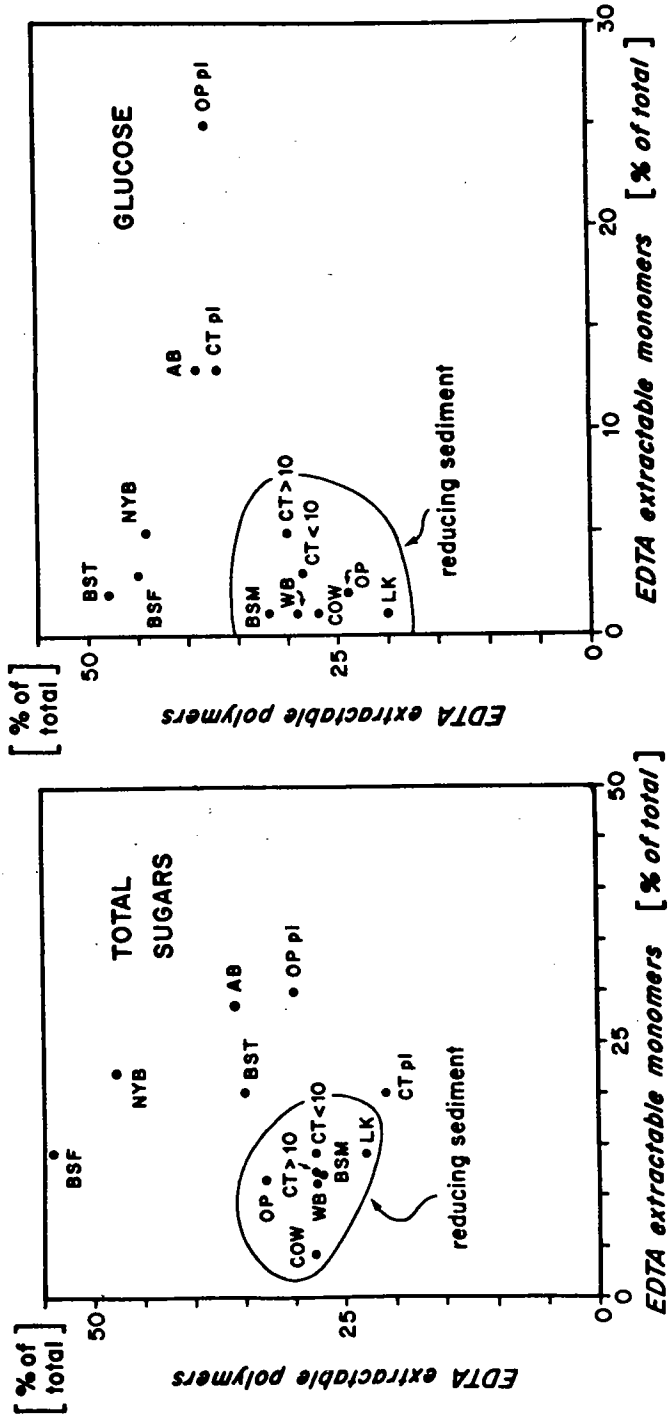

Figure 25

Relationship between EDTA extractable monomers and polymers in different sediment samples; data was drawn from Table III-1 in Appendix III; notation as in Figure 23.

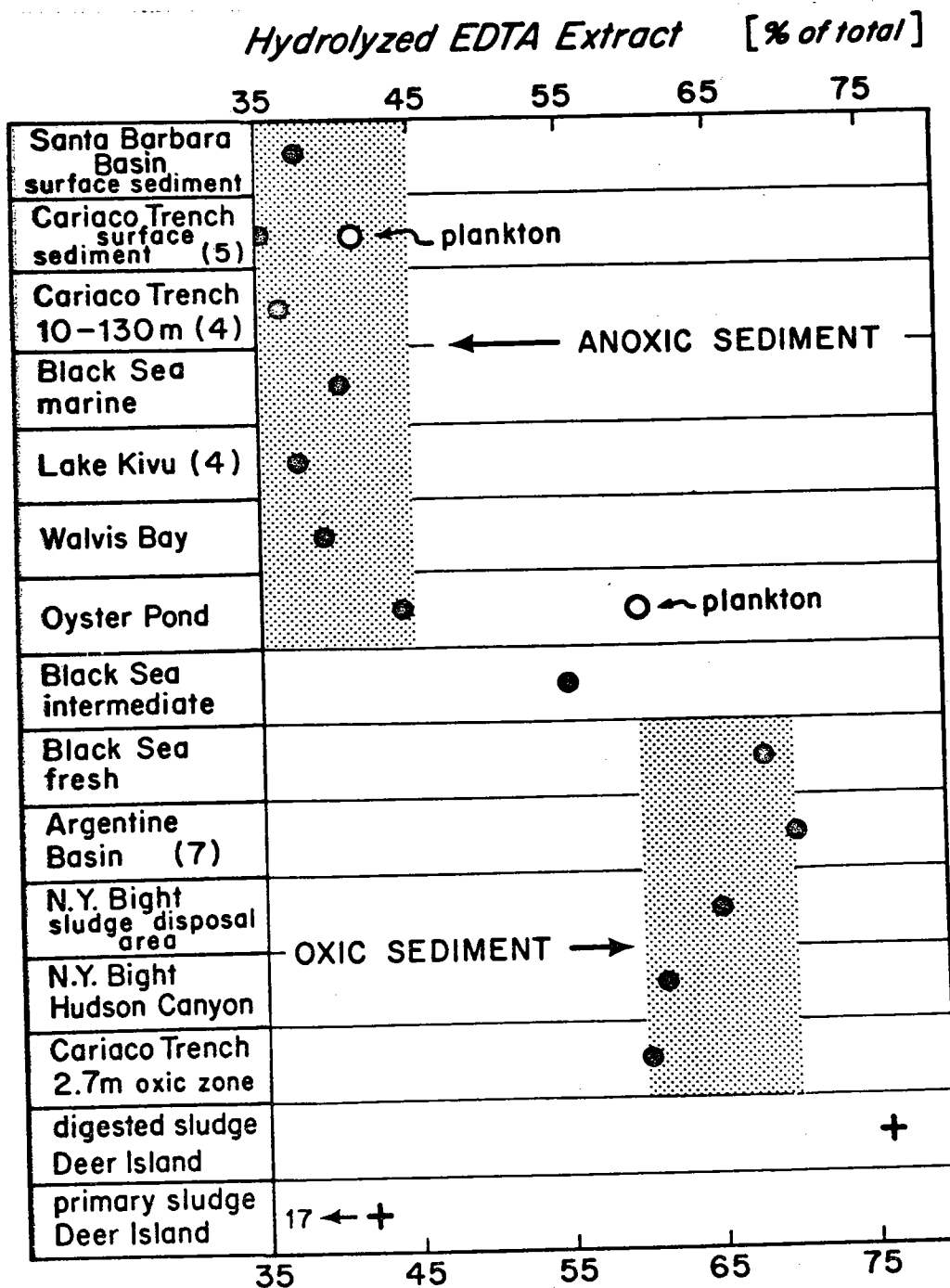

Figure 26

Comparison of the degree of metal binding of carbohydrates from various sedimentary environments. The % of HCl extractable sugars which is released by EDTA is 25-45% for reducing sediments and 55-75% for oxidizing sediments. The 'Black Sea Intermediate' sample represents the transition period from oxidizing to reducing. Digestion of primary sewage sludge has the effect of drastically increasing the degree of metal binding of the carbohydrate residue. The symbol () represents number of samples averaged.

(i) Degree of biological activity: Analyses of primary and digested sewage sludges suggest that metal-bound carbohydrates are refractory since they are the end-product of biological degradation. For example, Figure 26 shows that the percent of metal-bound (EDTA-extracted) sugars in the total acid extracted sugars increases from 17% in Deer Island primary sludge to 77% in the microbially digested Deer Island secondary sludge. The degree of metal binding induced by digestion of sewage sludge is similar to that of organic matter in oxic sediments. Thus, by analogy, the high degree of metal binding of organic matter in oxic sediments is probably attributable to intensive biological consumption.

The low degree of metal binding in reducing sediments implies that a large fraction of the carbohydrate residue of these sediments is potentially degradable, and hence, has been consumed to a lesser degree than in oxidizing sediments. The low rate of consumption in reducing environments reflects the low biological activity associated with the presence of an anaerobic population and with the absence of a metazoan biomass. Foree and McCarty (1970) demonstrated that anaerobic and aerobic microbial consumption rates are nearly identical under laboratory conditions, which suggests that the intensive consumption at oxic sediment-water interfaces is the result of the metazoan population, not the microbial population. (It is possible, however, that an active microbial community within the digestive tracts of the metazoan population is largely responsible for the degradation

(Allen and Sanders, 1966), as in the rumen of a cow.) This conclusion contradicts the frequently expressed opinion that free microorganisms rapidly degrade sedimentary organic matter even in deep-sea environments. This has seemed plausible because microbial counts may yield up to several million bacteria per gram of deep-sea surface sediment (e.g., Rittenberg et al., 1963). Based on the work of Jannasch et al. (1971) and Jannasch and Wirsen (1973), who examined in situ microbial degradation of organic substrates at the sediment-water interface, this viewpoint no longer seems tenable. Food stored at a water depth of 1500 m for several months showed negligible bacterial degradation. Organic substrates (e.g., agar, polysaccharides) inoculated at depth and embedded for several months in deep-sea sediment were utilized at rates up to several hundred times lower than control samples kept under refrigeration. In contrast, organic substrates placed in shallow water sediments were utilized at comparable or slightly lower rates than the controls. When clay was added to the substrates, decomposition rates did not increase even though the number of bacteria increased by a factor of 100 to 1000 relative to clay-free samples.

Thus, the absence of a metazoan population can explain the low rate of biological degradation in reducing environments and, hence, the low degree of metal binding.

Figure 27 shows that a relationship exists between the degree of metal binding, the total sugar carbon as % of the total organic carbon, and the degree of biological degradation. At the extremes of this plot are

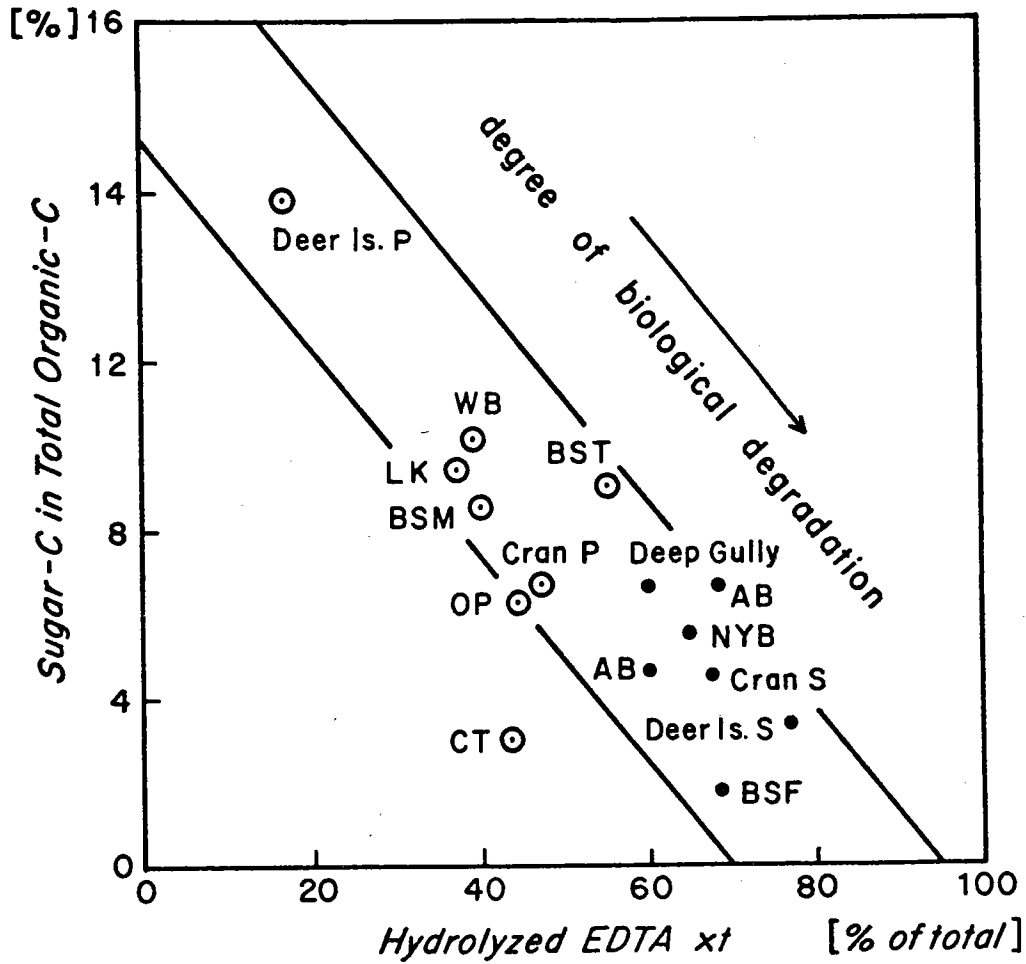

Figure 27

Relationship between sugar carbon (as % of total carbon) and hydrolyzed EDTA extracts of samples studied in this thesis. An inverse relationship exists: reducing sediments have high sugar carbon values and low degrees of metal binding; oxic sediments show the reverse trends; the degree of metal binding appears to be related to the degree of biological degradation; notation as in Figure 23; ⊙ = reducing sediments and primary sewage sludges; ● = oxic sediments and secondary sewage sludges.

the Deer Island primary and secondary sewage sludges. The primary sludge has a high sugar carbon value which corresponds to its large cellulose content; the degree of metal binding is low. After intensive microbial degradation (secondary treatment) the sugar carbon has greatly decreased and the degree of metal binding has correspondingly increased. Most sediments lie in between these extremes; reducing sediments lie closer to the undigested sludge while oxidizing sediments lie closer to the digested sludge.

(ii) Degree of metal ion availability: On the basis of K_{sp} data and the known concentrations of heavy metals in sulfide-free and sulfide-bearing seawater, one can calculate that the thermodynamic solubility of heavy metals in reducing environments is exceedingly low in comparison to that of oxidizing environments. The results of Presley *et al.* (1972), who analyzed heavy metals in the interstitial waters of reducing and oxidizing Saanich Inlet sediments, contradicts this expected trend. Very little difference in heavy metal concentrations exists between oxidizing and reducing sediment (with the exception of manganese which shows a 10-fold higher concentration in the reducing sediment). Generally, heavy metals show a 2 to 5-fold enrichment relative to seawater (Fe, Mn, and Zn demonstrate even higher enrichments). Thus, thermodynamic equilibria apparently do not control heavy metal concentrations in interstitial solutions. The authors attribute the enrichments to: (1) complexation by soluble organic matter; and/or (2) equilibration with unidentified mineral phases. No evidence was

given in support of either hypothesis. The former explanation is more consistent with the conclusions of this thesis.

It appears that the degree of metal binding of carbohydrates in sediments is primarily dependent upon the degree of biological degradation at the sediment-water interface. This conclusion is supported by the temporal distribution of bound carbohydrates in Argentine Basin (oxic) and Cariaco Trench (reducing) sediments shown in Figure 19. If it is assumed for the moment that continuing abiotic processes control the degree of binding of carbohydrates, then a diagenetic increase of metal binding with depth is expected, especially in Cariaco Trench sediments where carbohydrates are dominantly unassociated with metals. A temporal increase, however, is not apparent (it will be recalled that the peak of 2.65 m in the Cariaco Trench represents a band of oxic sediment). Thus, the degree of binding established at the zone of biological activity (0-10 cm) is maintained after burial within the time span sampled.

No correlation exists between the total sugar carbon (as % of the total organic carbon) and the C/N values of the sediments (Appendix II). Therefore it appears that carbohydrates are not preferentially consumed relative to nitrogenous organic compounds. However, a relationship does appear to exist between the degree of biological activity (expressed as the degree of metal binding of carbohydrates) and the C/N values as shown in Figure 28. Reducing sediments appear to have higher C/N values than oxidizing sediments, which suggests: (1) non-nitrogenous compounds,

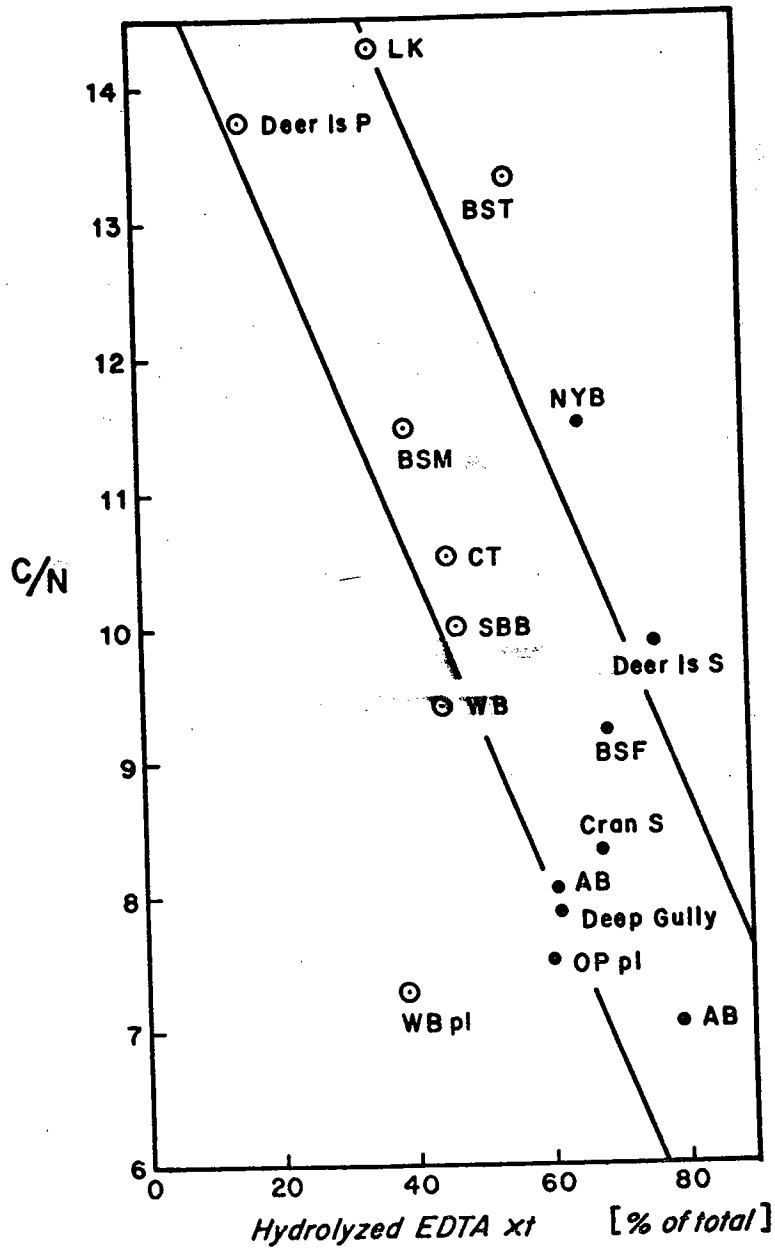

Figure 28

Relationship between C-N ratios (Appendix II) and hydrolyzed EDTA extracts of samples studied in this thesis. Reducing sediments and primary sewage sludges (○), which are characterized by a low degree of biological degradation, have higher C-N ratios than oxic sediments and secondary sludges (●), which are characterized by a high degree of biological degradation. Notation as in Figure 23.

with the exception of carbohydrates, are consumed preferentially in oxidizing environments, or (2) nitrogenous compounds are consumed preferentially in reducing environments.

2. PALEOENVIRONMENTAL CRITERIA

Figure 26 indicates that the degree of metal binding of sedimentary carbohydrates is related to the Eh at the sediment-water interface. Furthermore, Figure 19 shows that the degree of metal binding appears to remain fairly unaltered after burial; therefore, changes in environment at the sediment-water interface from oxidizing to reducing may be discerned as shown for the Cariaco Trench. In reducing environments the percent of the 'total' extracted with EDTA ranges from 30-45%; and in oxidizing environments the range is 60-75%.

Figures 17, 21, and 23 indicate that the glucose and ribose contents of sediment may be used to estimate the terrigenous input. Normal marine sediment generally contains about 20% glucose, and 3-6% ribose (Table 12) while sediment of a purely terrigenous origin (i.e., wood, peat, etc.) contains about 70% glucose and only traces of ribose. Sediment in which glucose represents $> 20\%$ of the total (or where glucose $>$ galactose) and where ribose represents $< 1\%$ of the total should be examined for a terrigenous organic input. Changes in the glucose to ribose ratios in sediment may correspond to changes in land run-off; this hypothesis is presently under examination.

Paleo-eutrophication conditions also may be discerned from carbohydrate analyses. For example, organic-rich sediments (such as the Black Sea sapropel layer) which contain a 'normal' algal sugar distribution (galactose dominant) probably reflect eutrophication in the surface waters.

CHAPTER VI

SUMMARY AND CONCLUSIONS

Aspects of the biogeochemical cycle in the ocean are shown in Figure 29. Two major organic inputs to sediment are emphasized: (i) labile particulate organic matter (P.O.M.) or seston, and (ii) inert P.O.M. The organic input of shallow water sediments is probably dominated by labile P.O.M. due to the high primary productivity and the low degree of degradation in the short water column. The organic input of deep-sea sediments is probably dominated by inert P.O.M. since the organic input from labile seston is probably less significant due to extensive degradation in the long water column and also to lower surface water productivity (for further details see Mopper and Degens, 1972; and Degens and Mopper, 1974).

Despite the differences in the organic inputs of shallow-sea and deep-sea oxic environments, carbohydrate compositions of surface sediments from these environments are almost identical (in terms of relative abundance of sugars, degree of metal binding, and % of total organic matter represented by carbohydrates) as shown for the Argentine Basin (deep), New York Bight (shallow), and Hudson Canyon (shallow). This uniformity is probably attributable to benthic bio-activity, which is high in shallow regions where 'edible' organics (seston) are abundant, and low in deep regions where 'edible' organics are probably scarce (Sanders and Hessler, 1969; Jannasch et al., 1971; Rowe, 1971; and Smith and Teal, 1973).

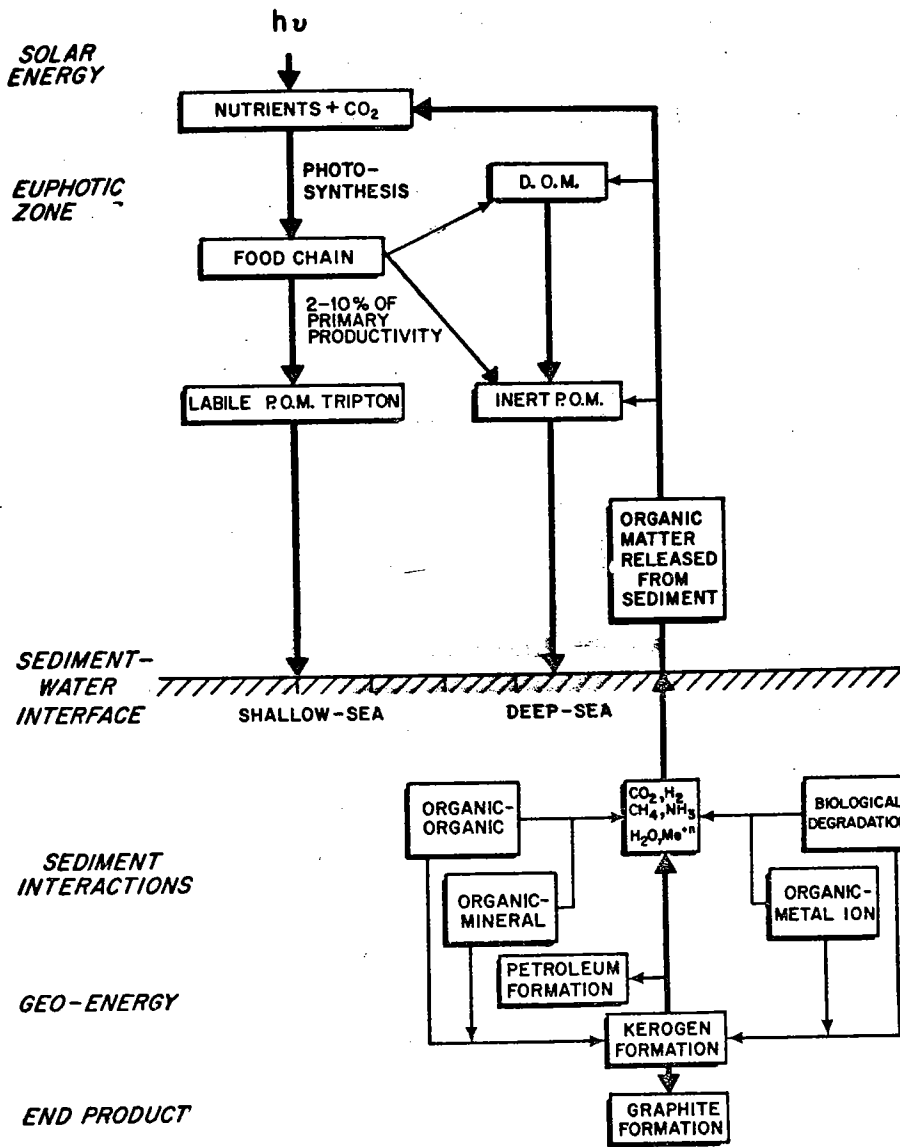

Figure 29

Hypothetical schematic of the biogeochemical cycle in the ocean; in this diagram the organic input of shallow-sea sediments is dominantly labile tripton derived from the local biomass; the organic input of deep-sea sediments is dominantly refractory particulate organic matter derived from both the degradation of tripton and the condensation of dissolved organic matter.

Thus, the carbohydrate composition of the end-products of metazoan degradation appears to be uniform, regardless of water depth. Surprisingly the orders of abundance of sugars extracted from sediment from reducing environments are also very similar to those of oxic environments (e.g., Table 12). Furthermore, for most sediments the orders of sugar abundance are similar to that of plankton, the ultimate source material. No one sugar is present in an overwhelming abundance, except for samples for which the organic input is dominantly terrigenous (glucose then dominates). The major difference between carbohydrates extracted from sediment from different depositional environments lies in their degree of metal binding.

In an oxic environment, biological degradation produces a highly-metal-bound (60-75%), water-insoluble carbohydrate residue. In a reducing environment, the degree of biological activity is low (relative to oxic environments) and hence the degree of metal binding of the resulting carbohydrate residue is low (30-45%). There is no evidence for further abiotic alteration after burial in either environment.

Sewage material dumped into a shallow-water oxic environment is degraded rapidly despite the high content of potentially toxic metals. It seems likely that those metals are tied-up in the ultimate metal bound carbohydrate residue. If sewage were dumped into a reducing or deep-sea environment, degradation would probably proceed very slowly.

Metal binding appears to fix potentially soluble carbohydrates (e.g., monosaccharides) in situ, thereby inhibiting diffusion (as shown

for the wood sample in Cariaco Trench sediments). This finding undercuts the previous belief that chromatographic separation of organic molecules along mineral surfaces is a significant early diagenetic process. Organic matter containing no (or low) functionality, such as hydrocarbons, would not be immobilized by such metal complexes.

Carbohydrates in sediment may be used to interpret paleo-environmental fluctuations. The degree of metal-organic interaction appears to reflect the Eh at the sediment-water interface. The cellulose content of the sediment may be used to estimate the terrigenous organic input. Paleo-eutrophic conditions in the surface waters may be discerned from organic-rich sediments by determining the relative proportions of algal and terrigenous sugars.

In conclusion, organic molecules in a living cell have a very complex structural order and are also far removed from thermodynamic equilibrium. Diagenesis of organic matter in sediment is expected to proceed in the direction of increasing thermodynamic stability. Initially, the organic input of sediment might be characterized as a loosely-structured conglomeration of various biomolecules in different states of preservation. Diagenesis probably leads to higher degrees of cross-linking of various kinds. The final product of late diagenesis, graphite, has achieved a very simple structural order. This order was obtained by the elimination of functional groups through condensation, deamination, decarboxylation, etc.; CO_2 , CH_4 , NH_3 , H_2O , and small organic molecules are released as by-products.

Although the structural nature of the carbohydrate containing residue of recent sediment has not been examined in this thesis, I present in Figure 30 an 'imagined' schematic model of this residue. I realize that at the present stage of research this model is highly hypothetical, however, I think that this type of model is useful in depicting possible interactions among organic molecules, metal ions, and minerals in sediment. Shown in Figure 30 are: (i) organic-organic condensations among carbohydrate, protein, lipid and lignin substances (the hashed lines represent hydrogen bonds); (ii) organic-mineral interactions such as condensation and adsorption of organic compounds onto the surface of a kaolinite-type mineral; (iii) organic-metal ion interactions; this type of interaction might help simplify the structural order of the residue through the formation metal-ion coordination polyhedra; the functional groups of different organic molecules might participate in the coordination; in one of the polyhedra shown a sulfide group (from cysteine) coordinates with a metal ion, and the larger ionic radius of the sulfide ion distorts the polyhedron; (iv) mineral-metal ion-organic interactions; oxygens on the mineral surface might also participate in metal-ion coordination polyhedra; (v) micelle formation; molecules which contain both hydrophobic and hydrophilic portions (e.g., fatty acids) might tend to aggregate so that the hydrophilic portion interacts with the aqueous environment and the hydrophobic portion is protected from the aqueous environment; indirect proof of the existence of micelles in sediment fulvic acid is given by Ogner and Schnitzer (1970).

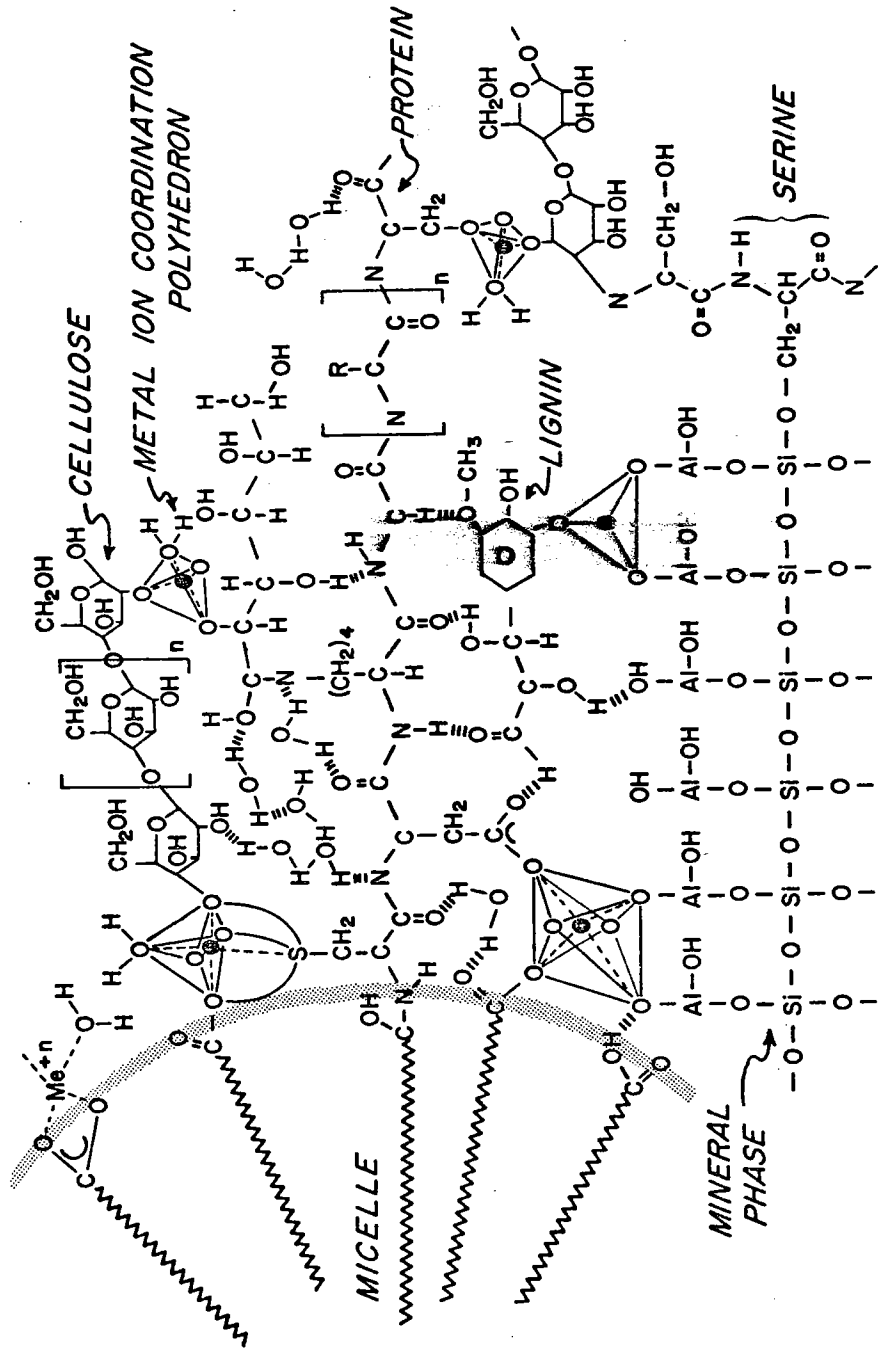

Figure 30

A highly hypothetical schematic of the carbohydrate-containing residue of sediment. Various possible interactions among organic molecules, metal ions, and minerals are shown.

REFERENCES

- Allen J. A., and Sanders H. L. (1966) Adaptations to abyssal life as shown by the bivalve Abra profundorum (Smith). *Deep-Sea Res.* 13, 1175-1184.
- Ardakani M. S. and Stevenson F. J. (1972) A modified ion-exchange technique for the determination of stability constants of metal-soil organic matter complexes. *Soil Sci. Soc. Amer. Proc.* 36, 884-890.
- Atlas of Pilot Charts (1955) Central American waters and South Atlantic Ocean. 2nd Ed, U.S. Navy Hydrographic Office, H.O. Pub. No. 576, Washington, D.C.
- Beckwith R. S. (1959) Titration curves of soil organic matter. *Nature* 184, 745-746.
- Bjerrum J. (1941) Metal Ammine Formation in Aqueous Solution, P. Haase and Son, Copenhagen.
- Blumer M. (1967) Equilibria and nonequilibria in organic geochemistry. In Equilibrium Concepts in Natural Water Systems. *Advances in Chemistry Series 67* (editor R. F. Gould). American Chemical Society Publications, Washington D. C., pp. 312-318.
- Bordovskiy O. K. (1965) Accumulation and transformation of organic substances in marine sediments. 2. Sources of organic matter in marine basins. *Mar. Geol.* 3, 5-31.
- Bourne, E. J., Nery R., and Weigel H. (1959) Metal chelates of polyhydroxy compounds. *Chem. Ind.*, 998-999.
- Breger I. A. and Brown A. (1962) Kerogen in the Chattanooga Shale. *Science* 137, 221-224.
- Bremner J. M., Heintze S. G., Mann P. J. G., and Lees H. (1946) Metallo-organic complexes in soil. *Nature* 158, 790-791.
- Broecker W. S., Turekian K. K. and Heezen B. C. (1958) The relation of deep-sea sedimentation rates to variations in climate. *Amer. J. Sci.* 256, 503-517.
- Charley P. J., Sarka B., Stitt C. F., and Saltman P. (1963) Chelation of iron by sugars. *Biochim. Biophys. Acta* 69, 313-321.

- Cheronis N. D. and Zymaris M. C. (1957) The microdetermination of reducing sugars in blood by means of p-anisyl tetrazolium blue. *Mikrochim. Acta* 6, 769-783.
- Clark J. S. and Turner R. C. (1969) An examination of the resin exchange method for the determination of stability constants of metal-soil organic matter complexes. *Soil Sci.* 107, 8-11.
- Coleman N. T., McClung A. C., and Moore D. P. (1956) Formation constants for copper-peat complexes. *Science* 123, 330-331.
- Corwin N. (1969) Reduced data reports for Atlantis II 31, 42, and 48: Appendix I. Techn. Rep. Woods Hole Oceanogr. Inst. Ref. No. 69-20, 1-4.
- Craig H. (1953) The geochemistry of stable carbon isotopes. *Geochim. Cosmochim. Acta* 3, 53-92.
- Dayhoff M. O., Lippincott E. R. and Eck R. V. (1964) Thermodynamic equilibrium in prebiological atmospheres. *Science* 146, 1461-1464.
- De Datta S. K., Franklin R. E., and Himes F. L. (1967) Partial characterization of soil polysaccharide-strontium 90-yttrium 90 complexes. *Soil Sci.* 103, 47-55.
- Deacon G. E. R. (1963) The southern ocean. In The Sea (editor M. N. Hill), Interscience Publishers, New York, pp. 281-296.
- Degens E. T. (1965) Geochemistry of Sediments: A Brief Survey. Prentice-Hall, New Jersey.
- Degens E. T., Emergy K. O., and Reuter J. H. (1963) Organic materials in recent and ancient sediments: III Biochemical compounds in San Diego Trough, California. *N. Jb. Geol. Paläont., Mh.* 5, 231-248.
- Degens E. T. and Reuter J. H. (1964) Analytical techniques in the field of organic geochemistry. In Advances in Organic Geochemistry (editors U. Colombo and G. O. Hobson), Pergamon Press, Oxford, pp. 377-402.
- Degens E. T., Reuter J. H., and Shaw N. F. (1964) Biochemical compounds in offshore California sediments and sea waters. *Geochim. Cosmochim. Acta* 28, 45-66.

- Degens E. T. (1969) Biogeochemistry of stable carbon isotopes. In Organic Geochemistry (editors G. Eglinton and M. T. J. Murphy), Springer-Verlag, New York, pp. 304-329.
- Degens E. T. and Ross D. A. (1970) Oceanographic expedition in the Black Sea: A preliminary report. *Naturwissenschaften* 57, 349-353.
- Degens E. T., Watson S. W. and Remsen C. C. (1970) Fossil membranes and cell wall fragments from a 7000-year old Black sea sediment. *Science* 168, 1207-1208.
- Degens E. T., Deuser W. G., von Herzen R. P., Wong H. K., Jannasch H. W., and Kanwisher J. W. (1971) Lake Kivu expedition: geophysics, hydrography, sedimentology (a preliminary report). Techn. Rep. Woods Hole Oceanogr. Inst. Ref. No. 71-52, 1-20.
- Degens E. T. and Ross D. A. (1972) Chronology of the Black Sea over the last 25,000 years. *Chem. Geol.* 10, 1-16.
- Degens E. T. and Ross D. A. (1973) (editors) The Black Sea: Its Geology, Chemistry, and Biology. Mem. Amer. Assoc. Petrol. Geol. (in press).
- Degens E. T., von Herzen R. P., Wong H. K., Deuser W. G., and Jannasch H. W. (1973) Lake Kivu: Structure, chemistry, and biology of an East African rift lake. *Geol. Rdsch.* 62, 245-277.
- Deuser W. G. (1972) Late-Pleistocene and Holocene history of the Black Sea as indicated by stable-isotope studies. *J. Geophys. Res.* 77, 1071-1077.
- Deuser W. G. (1973) Cariaco Trench: Oxidation of organic matter and residence time of the anoxic water. *Nature*, in press.
- Deuser W. G., Degens E. T., Harvey G. R. and Rubin M. (1973) Methane in Lake Kivu: New data bearing on its origin. *Science*, in press.
- Ebeling A. W. (1962) Melamphaidae I. Systematics and zoogeography of the species in the bathypelagic fish genus Melamphaes Günther. In Dana Report of the Carlsberg Foundation's Oceanographical Expedition Vol. XI no. 58, pp. 164.
- Emery K. O. (1969) A Coastal Pond: Studied by Oceanographic Methods, Elsevier, New York, pp. 1-80.
- Foree E. G. and McCarty P. L. (1970) Anaerobic decomposition of algae. *Environ. Sci. Techn.* 4, 842-849.

- Geering H. R. and Hodgson J. F. (1969) Micronutrient cation complexes in soil solution: 3. Characterization of soil solution ligands and their complexes with Zn^{++} and Cu^{++} . *Soil Sci. Amer. Proc.* 33, 54-59.
- Halvorson A. D. and Lindsay W. L. (1972) Equilibrium relationships of metal chelates in hydroponic solutions. *Soil Sci. Amer. Proc.* 36, 755-761.
- Handa N. and Yanagi K. (1969) Studies on the water-extractable carbohydrates of the particulate matter from the northwest Pacific Ocean. *Mar. Biol.* 4, 197-207.
- Hare P. E. (1969) Geochemistry of proteins, peptides, and amino acids. In *Organic Geochemistry: Methods and Results* (editors G. Eglinton and M. T. J. Murphy), Springer-Verlag, New York, pp. 438-463.
- Harvey H. W. (1960) *The Chemistry and Fertility of Sea Waters*. University Press, Cambridge, pp. 1-240.
- Hodgson J. F., Geering H. R., Norvell W. A. (1965) Micronutrient cation complexes in soil solution: Partition between complexed and uncomplexed forms by solvent extraction. *Soil Sci. Soc. Amer. Proc.* 29, 665-669.
- Hodgson J. F., Lindsay W. L., and Trierweiler J. F. (1966) Micronutrient cation complexes in soil solution: II. Complexing of zinc and copper in displaced solution from calcareous soils. *Soil Sci. Soc. Amer. Proc.* 30, 723-726.
- Hunt J. M. (1968) The significance of carbon isotope variations in marine sediments. In *Adv. in Org. Geochem. 1966* (editor G. D. Hobson), Pergamon Press, Oxford, pp. 461-483.
- Irving H. and Williams R. J. P. (1948) Order of stability of metal complexes. *Nature* 162, 746-747.
- Jannasch H. W., Eimhjellen K., Wirsen C. O. and Farmanfarmaian A. (1971) Microbial degradation of organic matter in the deep sea. *Science* 171, 672-275.
- Jannasch H. W. and Wirsen C. O. (1973) *In situ* response of deep-sea microorganisms to nutrient enrichment. *Science*, in press.
- Job P. (1928) Recherches sur la formation de complexes minéraux en solution, et sur leur stabilité. *Ann. Chim.* 9, 113-134.

- Jonsson P. and Samuelson O. (1967) Automated chromatography of monosaccharides on anion exchange resins. *J. Chromatogr.* 26, 194-201.
- Kesler R. B. (1967) Rapid quantitative anion-exchange chromatography of carbohydrates. *Anal. Chem.* 39, 1416-1422.
- Khanna S. S., and Stevenson F. J. (1962) Metallo-organic complexes in soil: I. Potentiometric titration of some soil organic matter isolates in the presence of transition metals. *Soil Sci.* 93, 298-305.
- Larsson L. and Samuelson O. (1965) An automated procedure for separation of monosaccharides on ion exchange resins. *Acta Chem. Scand.* 19, 1357-1364.
- Maksimov O. B., Prishchepo R. S., and Shvets T. V. (1972) The geochemical role of humic acid oxidation products. *Geochem. Intl.* 9, 135-141.
- Martell A. E. (1971) Principles of complex formation. In Organic Compounds in Aquatic Environments (editors S. J. Faust and J. V. Hunter), Marcel Dekker, New York, pp. 239-263.
- Martell E. A. and Calvin M. (1952) Chemistry of Metal Chelate Compounds, Prentice-Hall Inc., New York.
- Meeuse B. J. D. (1962) Storage products. In Physiology and Biochemistry of Algae (editor R. A. Lewin), Academic Press, New York.
- Miller M. H. and Ohlrogge A. J. (1958) Water-soluble chelating agents in organic materials: I. Characterization of chelating agents and their reactions with trace metals in soils. *Soil Sci. Soc. Amer. Proc.* 22, 225-228.
- Modzeleski J. E., Laurie W. A., and Nagy B. (1971) Carbohydrates from Santa Barbara Basin sediments: Gas chromatographic-mass spectrometric analysis of trimethylsilyl derivatives. *Geochim. Cosmochim. Acta* 35, 825-838.
- Moore S. and Stein W. H. (1951) Chromatography of amino acids on sulfonated polystyrene resins. *J. Biol. Chem.* 192, 663.
- Mopper K. (1970) A New Micro-Analytical System for Reducing Sugars. Masters Thesis, Mass. Inst. Technol.

- Mopper K. (1971) Some considerations of the effects of natural and man-made anoxic conditions on the surrounding environment. In Papers on National Land Use Policy Issues (Chairman H. M. Jackson), Senate, 92d Congress, pp. 189-198.
- Mopper K. and Degens E. T. (1972) Aspects of the biogeochemistry of carbohydrates and proteins in aquatic environments. Techn. Rep. Woods Hole Oceanogr. Inst. Ref. No. 72-68.
- Mopper K. and Degens E. T. (1972) A new chromatographic sugar auto-analyzer with a sensitivity of 10^{-10} moles. Anal. Biochem. 45, 147-153.
- Mopper K. and Degens E. T. (1974) Distribution and diagenesis of amino acids and sugars in sediments. Geochim. Cosmochim. Acta, submitted for publication.
- Mortensen J. L. (1963) Complexing of metals by soil organic matter. Soil Sci. Soc. Proc. 27, 179-186.
- Ogner G. and Schnitzer M. (1970) Humic substances: fulvic acid-dialkyl phthalate complexes and their role in pollution. Science 170, 317-318.
- Palacas J. G., Swain F. M. and Smith F. (1960) Presence of carbohydrates and other organic compounds in ancient sedimentary rocks. Nature 185, 234.
- Percival E. (1968) Marine algal carbohydrates. Oceanogr. Mar. Biol. Ann. Rev. 6, 137-161.
- Prashnowsky A., Degens E. T., Emery K. O., and Pimenta J. (1961) Organic materials in recent and ancient sediments: I. Sugars in marine sediment of Santa Barbara Basin, California. N. Jb. Geol. Paläont., Mh. 8, 400-413.
- Presley B. J., Kolodny Y., Nissenbaum A., and Kaplan I. R. (1972) Early diagenesis in a reducing fjord, Saanich Inlet, British Columbia - II. Trace element distribution in interstitial water and sediment. Geochim. Cosmochim. Acta 36, 1073-1090.
- Randhawa N. S. and Broadbent F. E. (1965) Soil organic matter - metal complexes: 6. Stability constants of zinc-humic acid complexes at different pH values. Soil Sci. 99, 362-366.

- Rashid M. A. and King L. H. (1970) Major oxygen-containing functional groups present in humic and fulvic fractions isolated from contrasting environments. *Geochim. Cosmochim. Acta* 34, 193-201.
- Reilley C. N., Schmid R. W., and Sadek F. S. (1959) Chelon approach to analysis (I): Survey of theory and application. *J. Chem. Ed.* 36, 555-564.
- Richards F. A. and Vaccaro R. F. (1956) The Cariaco Trench, an anaerobic basin in the Caribbean Sea. *Deep-Sea Res.* 3, 214-228.
- Richards F. A. (1965) Anoxic basins and fjords. In *Chemical Oceanography*, (editors J. P. Riley and G. Skirrow), Academic Press, London, pp. 611-645.
- Richards S., Pedersen B., Silvertown J. V., and Hoard J. L. (1964) Stereochemistry of ethylenediamine-tetraacetate complexes. *Inorg. Chem.* 3, 27-33.
- Rittenberg S. C., Emery K. O., Hulsemann J., Degens E. T., Fay C., Reuter J. H., Grady J. R., Richardson S. H. and Bray E. E. (1963) Biogeochemistry of sediments in experimental moxhole. *J. Sed. Petr.* 33, 140-172.
- Rogers M. A. (1965) Carbohydrates in aquatic plants and associated sediments from two Minnesota lakes. *Geochim. Cosmochim. Acta* 29, 183-200.
- Ross D. A., Degens E. T., and MacIlvaine J. (1970) Black Sea: Recent sedimentary history. *Science* 170, 163-165.
- Rowe G. T. (1971) Benthic biomass and surface productivity. In *Fertility of the Sea* (editor J. D. Costlow), Gordon and Breach Science Publ., New York-London-Paris, pp. 441-454.
- Ryther J. H. (1963) Geographic variations in productivity. In *The Sea* (editor M. N. Hill), Interscience Publishers, New York, pp. 347-380.
- Sackett W. M. and Thompson R. R. (1963) Isotopic organic carbon composition of recent continental derived clastic sediments of eastern Gulf Coast, Gulf of Mexico. *Bull. Am. Assoc. Petrol. Geol.* 47, 525-528.
- Samuelson O. (1963) *Ion Exchange Separations in Analytical Chemistry*, Almquist & Wiksell, Stockholm; Wiley, New York.

- Samuelson O. and Strömberg H. (1968) Partition chromatography of mono-, di- and trisaccharides on ion-exchange resins. *Z. Anal. Chem.* 236, 506-513.
- Sanders H. L. and Hessler R. R. (1969) Ecology of the deep-sea benthos. *Science* 163, 1419-1424.
- Schnitzer M. and Skinner S. I. M. (1965) Organo-metallic interactions in soils: 4. Carboxyl and hydroxyl groups in organic matter and metal retention. *Soil Sci.* 99, 278-284.
- Schnitzer M. and Skinner S. I. M. (1966) Organo-metallic interactions in soils: 5. Stability constants of Cu^{++} -, Fe^{++} -, and Zn^{++} - fulvic acid complexes. *Soil Sci.* 102, 361-365.
- Schnitzer M. and Skinner S. I. M. (1967) Organo-metallic interactions in soils: 7. Stability constants of Pb^{++} -, Ni^{++} -, Mn^{++} -, Co^{++} -, Ca^{++} -, and Mg^{++} - fulvic acid complexes. *Soil Sci.* 103, 247-252.
- Schnitzer M. and Hansen E. H. (1970) Organo-metallic interactions in soils: 8. An evaluation of methods for the determination of stability constants of metal-fulvic acid complexes. *Soil Sci.* 109, 333-340.
- Schnitzer M. (1971) Metal-organic interactions in soils and waters. In Organic Compounds in Aquatic Environments (editors S. J. Faust and J. V. Hunter), Marcel Dekker, New York, pp. 297-315.
- Schubert J. (1948) Use of ion exchangers for the determination of physical-chemical properties of substances, particularly radiotracers: I. *J. Phys. Coll. Chem.* 52, 340-350.
- Sillen L. G. and Martell A. E. (1964) Stability constants of metal-ion complexes. Special Publication #17, The Chemical Society, London.
- Simoneit B. R. and Burlingame A. L. (1972) Preliminary organic analyses of the DSDP (JOIDES) cores, Legs V-IX. In Advances in Organic Geochemistry 1971 (editors H. R. v Gaertner and H. Wehner), Pergamon Press, Oxford, pp. 189-228.
- Smith K. L. and Teal J. M. (1973) Deep-sea benthic community respiration: An in situ study of 1850 meters. *Science* 179, 282-283.
- Smith K. L., Rowe G. T. and Clifford C. H. (1973) New York Bight sludge dumping area: In-situ measurements of benthic oxygen demand. *Science*, submitted for publication.

- Stevenson F. J. and Butler J. H. A. (1969) Chemistry of humic acids and related pigments. In Organic Geochemistry: Methods and Results (editors G. Eglinton and M. T. J. Murphy), Springer-Verlag, New York, pp. 334-357.
- Stevenson F. J. and Cheng C.-N. (1970) Amino acids in sediments: Recovery by acid hydrolysis and quantitative estimation by a colorimetric procedure. *Geochim. Cosmochim. Acta* 34, 77-88.
- Stevenson F. J. and Cheng C.-N. (1972) Organic geochemistry of the Argentine Basin sediments: Carbon-nitrogen relationships and Quaternary correlations. *Geochim. Cosmochim. Acta* 36, 653-671.
- Swain F. M. (1958) Organic materials of early Middle Devonian, Mt. Union area Pennsylvania. *Bull. Amer. Ass. Petrol. Geol.* 42, 2858-2891.
- Swain F. M. (1963) Stratigraphic distribution of some residual organic compounds in Upper Jurassic. *Bull. Amer. Ass. Petrol. Geol.* 47, 777-803.
- Swain F. M. and Rogers M. A. (1966) Stratigraphic distribution of carbohydrate residues in Middle Devonian Onondaga beds of Pennsylvania and western New York. *Geochim. Cosmochim. Acta* 30, 497-509.
- Swain F. M., Rogers M. A., Evans R. D. and Wolfe R. W. (1967). Distribution of carbohydrate residues in some fossil specimens and associated sedimentary matrix and other geologic samples. *J. Sed. Petr.* 37, 12-24.
- Swain F. M., Pakalns G. V. and Brett J. G. (1968) Possible taxonomic interpretation of some Paleozoic and Precambrian carbohydrate residues. In Advances in Organic Geochemistry 1966 (editor G. D. Hobson), Pergamon Press, Oxford, pp. 461-483.
- Swain F. M. (1969) Fossil carbohydrates. In Organic Geochemistry: Methods and Results (editors G. Eglinton and M. T. J. Murphy), Springer-Verlag, New York, pp. 374-401.
- Swain F. M. and Bratt J. M. (1972) Comparative carbohydrate geochemistry of bay, salt marsh, and deep gulf sediments. In Advances in Organic Geochemistry 1971 (editors H. R. v. Gaertner and H. Wehner), Pergamon Press, Oxford, pp. 415-425.
- Tan K. H., King L. D., and Morris H. D. (1971) Complex reactions of zinc with organic matter extracted from sewage sludge. *Soil Sci. Soc. Amer. Proc.* 35, 748-752.

- Vallentyne J. R. and Bidwell R. G. S. (1956) The relation between free sugars and sedimentary chlorophyll in lake muds. *Ecology* 37, 495-500.
- Waksman S. A. (1933) The distribution of organic matter on the sea bottom and the chemical nature of humic acid. *Soil Sci.* 36, 125-147.
- Whittaker J. R. and Vallentyne J. R. (1957) On the occurrence of free sugars in lake sediment extracts. *Limnol. Oceanogr.* 2, 98-110.
- Wright J. R., and Schnitzer M. (1963) Metallo-organic interactions associated with podzolization. *Soil Sci. Soc. Proc.* 27, 171-176.
- ZoBell C. E. (1939) Occurrence and activity of bacteria in marine sediment. In Recent Marine Sediments (editor P. D. Trask), Amer. Ass. Petr. Geol., Tulsa, Oklahoma.
- ZoBell C. E. and Grant C. W. (1943) Bacterial utilization of low concentrations of organic matter. *J. Bact.* 45, 555-564.
- Zunino H., Galindo G., Peirano P., and Aguilera M. (1972) Use of the resin exchange method for the determination of stability constants of metal-soil organic matter complexes. *Soil Sci.* 114, 229-233.

APPENDIX I

DISCUSSION OF SAMPLE MATERIAL

APPENDIX I

DISCUSSION OF SAMPLE MATERIAL

Details of the organic carbon, organic nitrogen, organic hydrogen, water and CaCO_3 content of the samples discussed here are listed in Appendix II. Standard analytical techniques were employed to measure these parameters (Mopper and Degens, 1972).

a. Plankton

Plankton samples were obtained from different parts of the world; i.e., Cariaco Trench, Walvis Bay, off Iceland, off Bermuda, Humboldt Current, Lake Kivu and Oyster Pond (near Woods Hole). All samples (except Oyster Pond) were collected by an oblique tow from 200 meters to the surface with a #10 net. The samples represented a mixture of phytoplankton and zooplankton. No attempt was made to separate the two types prior to analysis.

b. Organic Waste Products

(i) Sewage Sludge: Primary and secondary sludges were obtained from treatment plants at Deer Island (Deer Island Treatment Plant, Winthrop, Massachusetts) and Cranston, Rhode Island (Water Pollution Control Facility). Briefly, screened and degrittied raw sewage is pumped into a sedimentation tank (primary) after which the settled sludge is pumped into a series of digestion tanks (secondary) where it is aerobically and anaerobically consumed. The efficiency of digestion is 60 to 70%. CH_4 ,

CO_2 , N_2 , and H_2 are released as by-products of the digestion processes.

Dried primary sludge has a fibrous texture which made crushing in a mortar difficult. Examination of the material through an optical microscope revealed the presence of such artifacts as hairs, cellulose fibers and glass fragments. Dried secondary sludge has a more amorphous texture and was easily crushed and homogenized in a mortar; no fibers or hairs were observed. The organic carbon contents of the Deer Island primary and secondary sludges are 36.0% and 35.9% respectively. The C/N ratio changes from 13.7 for the primary sludge to 9.9 for the secondary sludge. The δC^{13} values for the primary and secondary sludges are -24.2 and -23.3, respectively. The gross chemical and isotopic compositions apparently reveal little about structural changes and biochemical processes active in sludge digestion.

The sludges contain several percent heavy metals; secondary sludges have a 30-40% higher metal content than primary sludges.

(ii) Cow Manure: The manure sample was collected fresh from a local farm (Cape Cod). The sample was dried and analyzed immediately after collection. The sample had a fibrous appearance but was crushed easily after drying. The ease of crushing and homogenization suggested that structural components of the straw feed had been broken down by digestive processes in the cow. The material is almost exclusively organic as revealed by an organic carbon content of 43%. The C/N ratio is about 18.

c. Argentine Basin (ATLANTIS II Cruise #60, Leg 2, Station 21,
February-March 1971)

A 5 m gravity core in the northern part of the Argentine Basin (latitude $33^{\circ}50.09'S$, longitude $47^{\circ}48.62'W$) was taken at a water depth of approximately 3500 meters. Two distinct sedimentary units exist and their geological ages were determined by carbon-14 dating.

The upper unit, approximately 15 cm in length, consists of a light red-brown homogeneous clay. This unit approximately represents the present sediment-water interface because the gravity coring technique used does not severely disturb top sediments, as opposed to piston coring techniques where the top 10-50 cm may be lost. The organic carbon content of this unit is about 0.35%, which is the lowest value in the core. The low organic content of the surface sediment is probably due to the present-day low primary productivity in the region of the core as discussed below. The base of the unit was dated at 2000-3000 years B.P.

The lower unit (15 cm to 500 cm) is a grey-green clay. This unit is dominantly homogeneous, however, an occasional layer (1-2 mm thick) of sand and gravel is present. The source of these layers is probably ice-rafting or turbidity currents. The organic carbon content is variable but generally clusters between 0.6 to 0.7%. The age at the base of the core is approximately 90,000 years B.P.

The source of the inorganic fraction (clay) is probably the Rio de la Plata River, which drains the southern part of South America. No carbonates

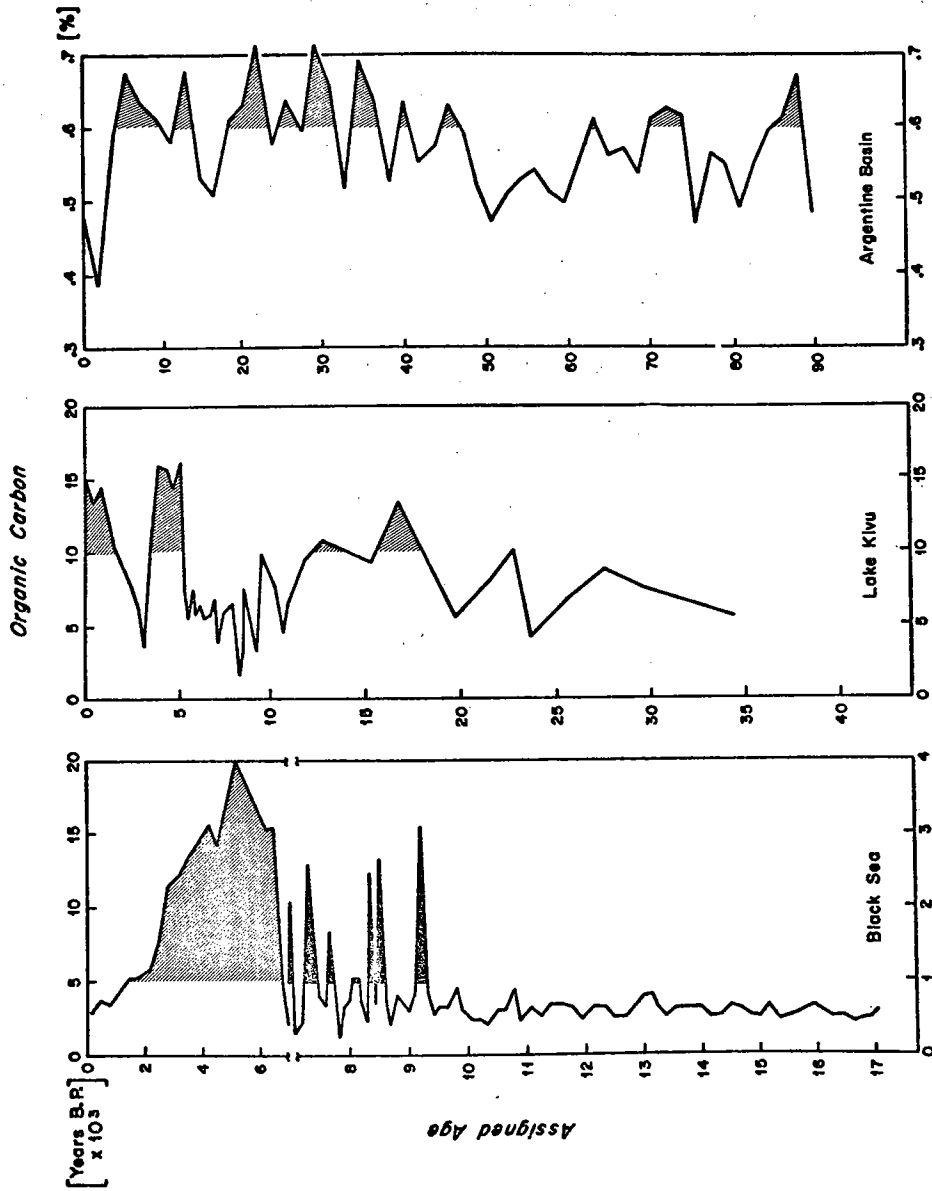

Figure I - 1

Fluctuations of organic carbon in cores from three different sedimentary environments: i) Black Sea - inland sea; ii) Lake Kivu - fresh lake; and iii) Argentine Basin - open ocean. Note that the lower portion of the Black Sea curve (> 6000 years) is plotted on an expanded scale in order to enhance the fluctuations.

were detected in the core.

Argentine Basin sediments are low in organic carbon relative to inland seas and lakes, such as the Black Sea and Lake Kivu (Figure I-1); however, in comparison to 'normal' open ocean sediments which generally contain 0.1-0.5% organic carbon (Bordovskiy, 1965), Argentine Basin sediments are enriched in organic carbon (0.5-1.0%). This relatively high organic content is probably related to high primary productivity in the surface water which, in turn, is probably related to upwelling in the area of the subtropical convergence near the edge of the continent (Ryther, 1963; Deacon, 1963). The subtropical convergence separates northward moving, nutrient-rich sub-Antarctic water from southward moving, nutrient-poor subtropical water. The productivity of the sub-Antarctic water is 150-250 g C/m²/yr, while the productivity of the subtropical water is about 50 g C/m²/yr (Ebling, 1962).

The distinct temporal variations of organic carbon shown in Figure I-1 for the Argentine Basin are not correlative with sea level fluctuations or glacial periods as found by Stevenson and Cheng (1972). The organic carbon fluctuations in the present core may be attributed to the following:

i) variations in surface productivity as a result of shifts in the subtropical convergence; these shifts may be initiated by changes in mean surface water temperature during glacial and interglacial periods; i.e., during glacial periods the mean position of the subtropical convergence moves northward in response to colder surface temperatures; seasonal shifts of several

hundred kilometers are well documented (Atlas of Pilot Charts, 1955) and are shown in Figure I-2 along with core positions; and ii) variations in land run-off due to eustatic changes in sea level; i.e., during glacial periods land run-off increases which results in higher sedimentation rates in the ocean (Broecker et al., 1958) which, in turn, results in dilution of the organic input of sediment. Therefore, fluctuations in the organic carbon content of the present Argentine Basin sediment appear to represent a resolution of two factors: sedimentation rate and primary productivity.

The water column in the area of the core has the following characteristics (Corwin, 1969): i) temperature and salinity vary from 21°C and 36.0‰ at the surface to 0.8°C and 34.7‰ at the sediment-water interface; and ii) the oxygen content is 5.1 ml/liter at the surface, 4.5 ml/liter at about 2000 m, and 5.1 ml/liter near the sediment-water interface (3500 m); the average oxygen content for the water column is 5.2 ml/liter.

d. New York Bight and Hudson Canyon (GOSNOLD Cruise 187, April 1972)

Three surface samples were collected in the vicinity of the New York Bight sewage disposal area. The samples were frozen immediately after collection. The sediment was placed through a 0.5 mm screen prior to extraction to remove large animals.

One sample (labelled 'Buoy Station') is from the periphery of the disposal area (water depth ~30 m). Raw, primary and secondary treated sewage are dumped in this area. The water is oxic down to the

Figure I-2

Seasonal positions of the subtropical convergence in the Argentine Basin (Atlas of Pilot Charts, 1955). The productivity south of the con-

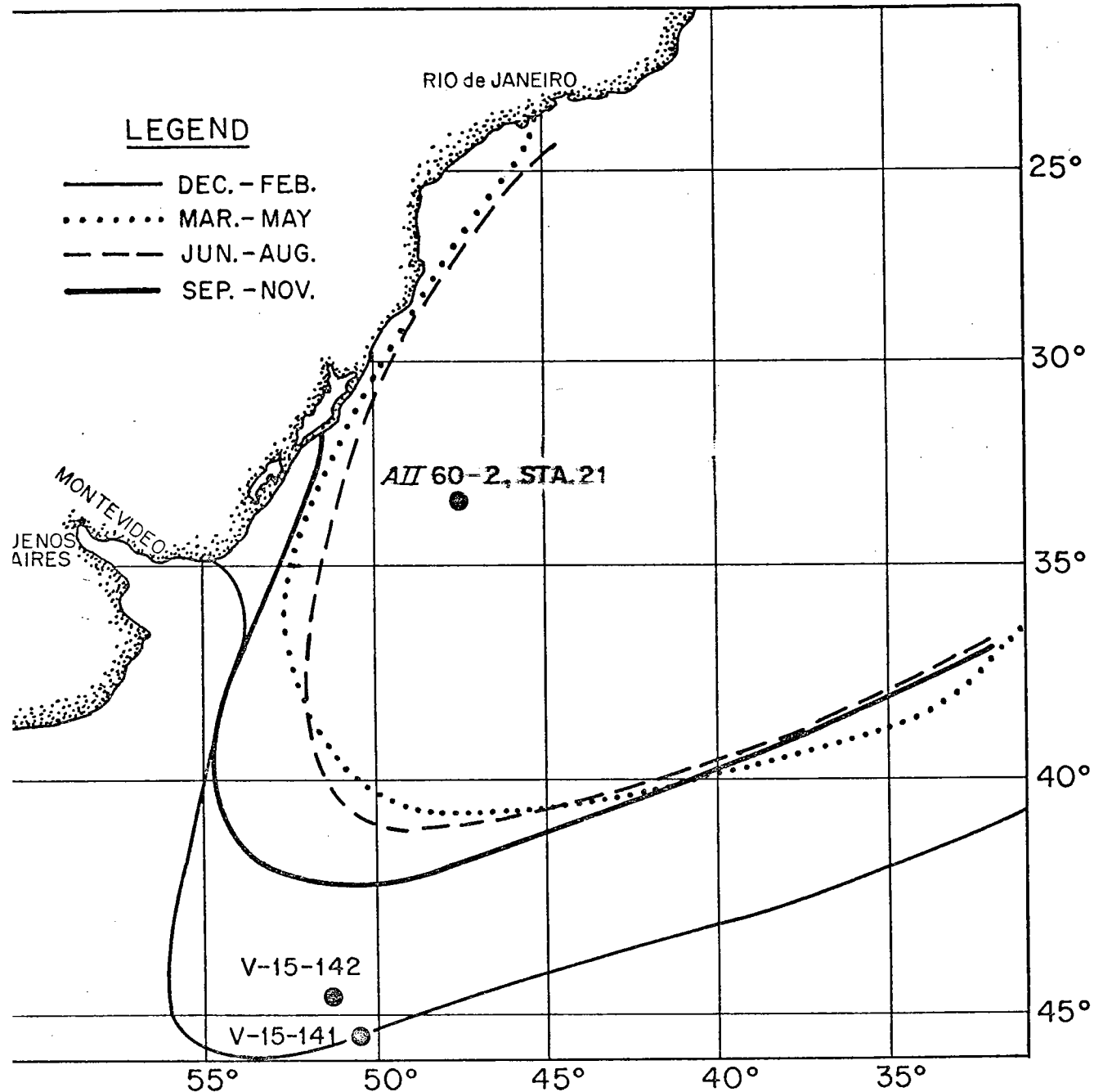

vergence is high ($\sim 150-250 \text{ g C/m}^2/\text{yr.}$) while the productivity north of the convergence is low ($\sim 50 \text{ g C/m}^2/\text{yr.}$). Movements of the subtropical convergence may affect the organic carbon content of the sediment. The AII-60 station is described in this thesis; V-15 stations are described in Stevenson and Cheng (1972).

sediment-water interface. The surface sediments at the Buoy Station are characterized by having one of the highest biological consumption rates in the world's oceans (Smith et al., 1973).

The other samples (Mid-Gully and Deep Gully) are from the Hudson Canyon near the disposal area. These samples are more characteristic of normal shallow-sea sediments with respect to organic carbon contents and biological consumption rates.

- e. Cariaco Trench (ATLANTIS II Cruise #60, Stations 1788P and 1798P₂, July-August 1971; J.O.I.D.E.S. Leg 15, Drilling Site 147, January 1971)

The Cariaco Trench is a marine anoxic basin off the coast of Venezuela. It measures 180 km long in the east-west direction and up to 60 km wide in the north-south direction. The trench has a maximum depth of 1400 m and is separated from the rest of the Caribbean Sea by a sill which has a maximum depth of 140 m. The residence time for the deep water is about 100-200 years (Deuser, 1973). The O₂-H₂S interface occurs at about 300 m. The maximum H₂S concentration is about 0.03 mg A sulfide - S/l. For details, see Richards and Vaccaro (1956) and Richards (1965).

A piston core at station 1788P was taken at water depth of 435 m in the eastern portion of the trench; 315 cm of sediment were recovered. Two sedimentary units exist; the top unit (0-120 cm) is a dark green-grey H₂S-rich laminated sediment. Wood is encountered at a sediment depth of about

60-80 cm; evidently a log buried in the sediment was penetrated by the coring device. The age of the wood as determined by C-14 methods is 5400 years B.P.; based on this date, a sedimentation of 10-20 cm/1000 years was estimated.

This sedimentation rate is low since it is not known how long the log floated before settling to the bottom. J.O.I.D.E.S. results indicate a sedimentation rate of 50 cm/1000 years is more appropriate. Omitting the wood, the average organic carbon content of this unit is 5% and the CaCO_3 content is about 35%.

The second unit (120-315 cm) is also laminated and H_2S -rich; however, the color is generally a lighter green-grey. The laminated sediment is interspersed with three 10-20 cm gelatinous water-rich bands. The average organic carbon content of the unit is 4% and the CaCO_3 content is about 15%.

The core at Station 1798P₂ resembles the above core (but with no wood); a third unit consisting of oxidized sediment is encountered 255 cm below the top of the core. This unit is uniformly light grey with no apparent laminations. The organic carbon content is 1-2% and the CaCO_3 content is 25%. Metal analyses indicated that this unit was deposited under oxidizing conditions (Price, pers. comm.).

The J.O.I.D.E.S. core at drilling site 147 in the western portion of the Cariaco Trench is described in detail in the Initial Report #15 (1973, in preparation). The core length is 189 m. Four distinct sedimentary rhythms

are observed. Briefly, each rhythm is composed of: i) greyish olive-green calcareous clay; ii) grey and brown calcareous clays; and iii) vari-colored calcareous and dolomitic clays. The first rhythm is 13 m long; the second, 90 m long; the third, 16 m long; and the fourth, 70+ m long.

Pyrite is abundant throughout the length of the core (except in the oxic zones). The detrital minerals, such as plagioclase, orthoclase, hornblende and zoisite, indicate a metamorphic province as the source of the inorganic fraction. Clay and CaCO_3 (predominately nanno-fossils and foraminifera) abundances appear to be inversely related; this trend may reflect changes in land run-off.

f. Santa Barbara Basin ($34^{\circ}17'N$, $120^{\circ}05'W$)

Two marine sediment samples were collected and described by Modzeleski et al. (1971). The samples were taken at depths of 35 and 160 cm below the sediment-water interface and were dated at 50 ± 10 years and 750 ± 50 years, respectively. Dating was accomplished by counting seasonal varves with an X-ray technique. The samples consist of dark brown-green H_2S -rich mud. The samples were frozen immediately after collection. Prior to analyses the frozen samples were washed with distilled water and freeze-dried for storage. For details of the Santa Barbara Basin see Emery (1960).

g. Walvis Bay (ATLANTIS II Cruise #42, Station 187, May 1968)

An anchor dredge (surface sediment) sample was collected at a water depth of about 600 m. The sample was frozen immediately after preliminary

examination of the indigenous fauna. The sample is a dark green-grey H_2S -rich mud. The organic carbon content is 6-7% and the C/N ratio is about 7. The high organic content probably reflects high primary productivity at the surface waters ($\sim 400 \text{ g C/m}^2/\text{yr}$). Examination of the oxygen profile in the overlying water (Corwin, 1969) indicates that oxygen concentrations decrease rapidly from a normal value of about 5 ml/liter at the surface to > 1 ml/liter near the bottom. The oxygen concentration just above the sediment-water interface is zero. The bottom temperature is about 5°C .

h. Black Sea (ATLANTIS II Cruise #49, Station 1474, April-May 1969)

Two cores in the eastern basin were taken at a water depth of about 2,200 m. A square box core (15 x 15 cm) 6 m long, and a piston core 12 m long were examined. The upper 50 cm of the piston core were lost during the coring operation. Three distinct sedimentary units were defined and their geologic ages were determined by radiocarbon methods.

The uppermost unit, 30 cm thick, is composed of alternating black and white layers, 50 to 100 per cm. The white layers are calcitic and are composed almost entirely of the coccolithophorid Emiliana huxleyi, and the darker layers are composed of organic-rich material. The base of the unit is about 3000 years B.P.

The second unit, about 40 cm thick, is dark brown and has a jelly-like appearance. On the dry weight basis, the content of organic matter is as high as 40%. Microlaminae are still recognizable, but because of lower

color contrast, they are less pronounced than in the uppermost unit. The second unit is further characterized by the occurrence of three distinct white bands, a millimeter or less thick and consisting dominantly of various species of coccolithophorid and aragonite grains. The base of the unit corresponds to a C^{14} age of 7000 years.

The third unit consists of a sequence of alternating light and dark lutite bands. The upper meter of the unit is marked by a drop in organic carbon from about 2 percent to 0.3 percent. These changes take place in the time interval between 7000 and 10,000 years B.P. The indigenous coccoliths of the upper two units are absent in the basal section. Only a few fragments of Eocene and Cretaceous coccoliths are found and are probably of terrigenous origin. The base of the piston core has a carbon-14 age of about 25,000 years B.P.

It is of interest to note that not only can these three sedimentary units be traced along the entire length of the Black Sea, but layers as thin as 1 mm are correlative over 1000 km. This ubiquity of distinct layers suggests that uniform environmental conditions prevailed over most of the basin at any one time.

In the Black Sea the environment at the sediment-water interface has changed several times from oxic fresh water to anoxic marine during the last 25,000 years (Degens and Ross, 1972). The frequency of marine spills and fresh water dominance is recorded by the fossils assemblages; the redox conditions at the sediment-water interface is reflected in the mineralogy of

the sediments. The organic carbon content also mirrors these changes as shown in Figure I-1.

The interpretation was offered (Degens and Ross, 1970) that between 17,000 and 9300 B.P. the Black Sea constituted an oxygenated fresh water body for its entire depth. Around 9300 years B.P. the first invasion of Mediterranean water occurred, which produced reducing conditions at the sediment-water interface for about 200 years. The frequency of saline spills with concurrent reducing conditions at the sea bottom over the next 2000 years was reflected in the sedimentary organic carbon fluctuations (Figure I-1). Finally, at 7300 years B.P. the influx of Mediterranean water became so pronounced that saline (brackish) and reducing conditions were permanently established at the sediment-water interface. The shape of the organic carbon curve from 7000 years B.P. to present was principally the result of changes in the rate of deposition which, in turn, was controlled by variations in the productivity of calcareous organisms (coccoliths).

For further information see Ross et al. (1970), Degens and Ross (1970, 1973).

i. Oyster Pond, Woods Hole (May 1972)

Oyster Pond is a coastal pond, 1100 m long in the north-south direction and up to 300 m wide. The maximum water depth is 6 m. A strong halocline exists for most of the year in the southern portion of the pond; in the upper 4 m the chlorinity is 1.0-2.0‰ while in the lower meter the chlorinity is 5.0-6.0‰. The presence of this halocline gives rise to

anoxic conditions at the sediment-water interface (infrequent overturns have been observed).

A surface sediment sample was taken in the southern central portion of the pond. The sediment-water interface at the time of sampling was anoxic. The sediment is a dark brown H_2S -rich clay. The $CaCO_3$ content is less than 1%. The organic carbon content is 11% and the C/N ratio is 10.

The high organic content reflects high primary productivity at the surface ($100-200 \text{ g C/m}^2/\text{yr}$). Although land-derived organic input is more important near the shore than at the center of the pond, as revealed by normal marine C/N ratios and δC^{13} values. A complete description of Oyster Pond is given by Emery (1969).

j. Lake Kivu (D-4 Cruise, February-March 1971 and March 1972)

Lake Kivu is situated at the highest point along the East African Rift Valley and is surrounded by active volcanos and geothermal springs. The lake measures 100 km in north-south and up to 40 km in east-west directions. The maximum water depth is 500 m. Two cores were studied in the present investigation. On the basis of radiocarbon dates and estimated sedimentation rates, the base of the longest core, 930 cm, was assigned an age of approximately 35,000 years.

In the deep basins (350 m) four distinct sedimentary units are defined. The upper unit, about 150 cm thick, is composed of alternating dark brown gel-like bands and white layers, about 50 layers per cm. This

varve-like pattern is enhanced due to the high water content of the sediment (90-95%). The second unit is also finely laminated and contains up to 100 layers per cm; however, the dark brown gel-like bands which are dominant in the top unit are missing. Ash layers occur frequently at the base of this unit. The third unit is characterized by reappearance of brown sapropelic layers at a depth of approximately 300 to 400 cm in deep basin cores. The basal unit of the longest core (930 cm) consists dominantly of micro-laminations.

Diatoms are the principal fossils in all units. In the three lower units (35,000 to 6000 years B.P.), sediments alternate between Stephanodiscus astrea dominance and Nitzschia fonticola dominance. In the upper unit, various uncommon species of Nitzschia are dominant.

The organic carbon pattern in Lake Kivu sediments reveals three major peaks at 15,000, 5000, and zero years B.P. (Fig. I-1). Paleontological and geochemical evidence indicate that the lake level was high at these periods due to increased pluvial activity and an increased discharge of hydrothermal waters as a result of volcanic activity (for further details see Degens et al., 1971, 1973; and Deuser et al., 1973).

k. C/N Ratios of Various Sediments

The C/N ratios of the Black Sea, Cariaco Trench, Argentine Basin, Santa Barbara Basin and Lake Kivu sediments are plotted in Fig. I-1. Lake Kivu shows a systematic increase in C/N ratios with time, while the other areas show constant ratios with time. Lake Kivu is in an area of active

There is no page 180

volcanism and hydrothermal activity; emissions of volcanic gasses and hydrothermal waters from the lake floor have been observed. Therefore, nitrogen-containing compounds in the sediment probably undergo thermal decomposition. The ammonia produced is flushed from the sediment by percolating hydrothermal solutions (Degens et al., 1973).

APPENDIX II

BACKGROUND DATA

Appendix II
Background Data

Sample	Organic C (%)	Organic N (%)	Organic H (%)	C/N	CaCO ₃ (%)	H ₂ O (%)	dry wt. analyzed (g)	1.8N HCl (ml)	EDTA (g)
<u>Plankton:</u> Cariaco	43.9	7.3	6.2	6.0	2.1	N.D.	.05	10	1
off Iceland	54.4	6.0	7.7	9.1	--	N.D.	.05	10	N.D.
Malvis Bay	N.D.*	N.D.	N.D.	N.D.	N.D.	N.D.	.05	10	N.D.
Humboldt Current 1a	45.3	7.7	6.2	5.9	15.0	N.D.	.05	10	N.D.
7a	48.5	7.3	7.0	6.6	2.6	N.D.	.05	10	N.D.
15a	41.1	5.4	5.9	7.7	8.0	N.D.	.05	10	N.D.
Lake Kivu	N.D.	N.D.	N.D.	N.D.	N.D.	N.D.	~.005	10	N.D.
Off Bermuda	50.0	5.9	7.0	8.4	1.0	N.D.	.05	10	N.D.
Oyster Pond	54.5	7.3	7.5	7.5	2.0	90	.53(wet)	10	1
<u>Sewage Sludge:</u> Deer Is. Prim.	36.0	2.6	4.9	13.7	--	~99	.1	10	1
Deer Is. Sec.	35.9	3.6	5.1	9.9	--	~99	.1	10	1
Cranston Prim.	39.5	3.8	5.5	10.4	--	~99	.1	10	1
Cranston Sec.	30.3	3.7	4.2	8.2	--	~99	.1	10	1
COW manure	42.8	2.3	5.4	18.4	--	~99	.5	10	2

* N.D. = not determined

Background Data (cont.)

Sample	Organic C (%)	Organic N (%)	Organic H (%)	C/N	CaCO ₃ (%)	H ₂ O (%)	dry wt. analyzed (g)	1.8N HCl (ml)	EDTA (g)
<u>N.Y. Bight:</u>									
Buoy St.	2.5	.22	.37	11.5	.59	55	.2	10	1
Mid Gully	1.3	.15	.27	8.9	1.0	43	.4	10	N.D.
Deep Gully	1.0	.13	.22	7.9	.60	45	.4	10	1
<u>Argentine Basin (cm):</u>									
0	.48	.070	N.D.	6.9	--	44	2	10	1
5	.23	.063	.09	2.7	--	42	2	10	1
15	.60	.062	.09	7.3	--	44	2	10	1
20-50	.64	.063	.08	8.0	--	46	.5-2	10	1
60	.58	.075	N.D.	7.7	--	45	2	10	1
100	.61	.073	N.D.	8.3	--	45	2	10	1
300	.52	.062	N.D.	8.5	--	42	2	10	1
500	.48	.044	N.D.	10.9	--	45	2	10	1
<u>Black Sea (cm):</u>									
15	3.9	.34	.72	11.5	61.0	44	.4	10	1.5
65-70	20.0	1.5	3.3	13.3	6.0	45	.2-.4	10	1
120-130	1.2	.13	.57	9.2	26.3	46	1	10	1-2

Background Data (Cont.)

Sample	Organic C (%)	Organic N (%)	Organic H (%)	C/N	CaCO ₃ (%)	H ₂ O 2 (%)	dry wt. analyzed (g)	1.8N HCl (ml)	EDTA (g)
<u>Lake Kivu</u>									
(cm):									
125	15.0	1.1	N.D.	14.3	--	91	.4	10	1
(st. 10)									
240	6.7	.33	N.D.	18.6	15.2	76	.4	10	1
530	5.8	.29	1.2	20.1	1.1	81	.2	10	1
(st. 4)									
930	4.8	.30	1.3	15.6	1.1	N.D.	.2	10	1

Cariaco Trench

(m):									
.15	5.8	.57	N.D.	10.2	41.1	61	.5	10	1.5
.60	4.6	.45	N.D.	10.2	35.6	59	.5	10	1.5
.64 (wood)	36.1	.27	N.D.	134.0	--	87	.2	10	1
1.0	4.9	.48	N.D.	10.2	23.2	59	.5	10	1
1.3	4.1	.36	N.D.	11.4	2.4	84	.5	10	1
1.8	4.3	.34	N.D.	12.5	19.1	81	.5	10	1
2.4	4.3	.42	1.1	10.3	19.3	N.D.	.5	10	1
2.7 (oxic)	.9	.14	.73	6.3	25.7	N.D.	1.0	10	1.5
10	2.5	.25	N.D.	9.9	32.2	66	.5	10	1.5
40	1.9	.17	N.D.	11.2	10.6	42	1.0	10	1
67	1.6	.17	N.D.	9.7	33.8	28	1.0	10	2
130	1.5	.14	N.D.	10.2	21.0	29	1.0	10	1.5

Background Data (cont.)

Sample	Organic C (%)	Organic N (%)	Organic H (%)	C/N	CaCO ₃ (%)	H ₂ O (%)	dry wt. analyzed (g)	1.8N HCl (ml)	EDTA (g)
Walvis Bay	5.9	.81	N.D.	7.3	.82	79	.5	10	1
Bermuda	.57	.05	N.D.	11.1	24.9	41	2	10	N.D.
Oyster Pond	9.4	1.0	N.D.	9.4	1.4	N.D.	.2	10	1
Santa Barbara (~50 years)	11.6	N.D.	N.D.	N.D.	10.0	N.D.	1	10	1
(~750 years)	12.3	N.D.	N.D.	N.D.	13.8	N.D.	1	10	N.D.
Peat:									
Georges Bank	46.8	1.1	4.6	43.0	--	N.D.	.1	10	N.D.

APPENDIX III

DATA FILE OF CARBOHYDRATE ANALYSES

TABLE III-1

TOTAL PERCENTAGES OF SUGARS EXTRACTABLE BY EDTA - TREATMENT
OF SEDIMENTS AND ORGANIC WASTE PRODUCTS

Sugar:		Rh	Fu	Ri	A	X	M	Ga	G1	Total
Cariaco Trench										
<10 m	a*	9	25	93	30	19	2	10	3	14
(6)	b	34	34	--***	21	23	20	28	28	28
	c	57	41	7	49	58	78	62	69	58
Cariaco Trench										
>10 m	a	12	25	49	19	20	5	10	5	12
(3)	b	48	34	--	19	25	24	29	30	28
	c	40	41	51	62	55	71	61	64	60
Plankton above										
Cariaco Trench										
	a	15	54	93	97	31	4	7	13	20
	b	31	19	--	9	21	27	20	37	21
	c	54	27	7	--	48	69	73	50	59
Black Sea										
(Marine) 15 cm										
	a	9	23	43	26	15	1	11	1	12
	b	91	43	0	36	10	17	42	32	28
	c	0	34	57	38	75	82	47	67	60
Black Sea (Transition)										
65 cm	a	20	30	79	22	31	3	18	2	20
	b	50	35	--	20	30	45	29	48	35
	c	30	35	21	58	39	52	53	50	45
Black Sea (Fresh)										
125 cm	a	13	25	76	32	15	3	11	3	14
	b	71	103	89	41	61	56	44	45	54
	c	16	---	--	27	24	41	45	52	32
Walvis Bay, Sediment										
Surface										
	a	8	15	74	22	19	5	8	1	11
	b	33	18	--	12	28	48	27	29	28
	c	59	67	26	66	53	47	65	70	61
Lake Kivu,										
130 cm										
	a	19	38	53	51	32	2	23	1	14
	b	52	31	--	26	36	48	16	20	23
	c	29	31	47	23	31	50	61	79	63
Argentine Basin										
5 m (2)	a	30	43	94	39	38	9	20	13	28
	b	52	37	--	14	30	44	50	39	36
	c	19	20	6	47	32	47	30	48	36

TABLE III-1 continued

TOTAL PERCENTAGES OF SUGARS EXTRACTABLE BY EDTA - TREATMENTOF SEDIMENTS AND ORGANIC WASTE PRODUCTS

Sugar:	Rh	Fu	Ri	A	X	M	Ga	G1	Total	
Oyster Pond, Sediment										
Surface	a	10	24	63	34	15	2	8	2	11
	b	44	43	37	31	34	29	39	24	33
	c	46	33	0	35	51	69	53	74	56
Oyster Pond, Plankton										
	a	12	46	48	5	19	5	37	25	30
	b	58	39	28	40	18	35	20	38	30
	c	30	15	24	55	63	60	43	37	40
N.Y. Bight, Sediment										
Surface	a	16	39	123	54	36	5	18	5	22
	b	60	48	---	27	27	49	50	44	43
	c	24	13	---	19	37	46	32	51	35
Wood in Cariaco Trench Sediment, .64 m										
	a	16	63	0	88	23	5	19	1	15
	b	26	7	100	--	--	6	9	0	1
	c**	58	30	0	12	77	89	72	99	84
Cow Manure										
	a	5	33	---	44	2	3	9	1	8
	b	53	--	---	25	26	11	57	27	28
	c	42	67	---	31	72	86	34	72	64
Deer Island Sewage Sludge Primary										
	a	19	52	120	102	8	2	13	1	6
	b	54	27	----	----	17	17	56	4	11
	c**	27	21	---	---	75	81	31	95	83
Deer Island Sewage Sludge Digested										
	a	23	71	194	101	12	3	14	2	17
	b	128	119	45	55	52	52	107	16	60
	c**	----	----	----	----	36	45	---	82	23
Cranston Sewage Sludge Primary (1972)										
	a	6	19	45	61	2	1	4	2	6
	b	70	51	36	22	6	22	67	46	41
	c	24	30	19	17	92	77	29	52	53

TABLE III-1 continued

TOTAL PERCENTAGES OF SUGARS EXTRACTABLE BY EDTA - TREATMENTOF SEDIMENTS AND ORGANIC WASTE PRODUCTS

Sugar:	Rh	Fu	Ri	A	X	M	Ga	G1	Total
Cranston Sewage Sludge									
Digested (1972)									
a	7	37	93	60	2	2	7	1	11
b	76	56	--	36	11	28	76	58	45
c	17	7	7	4	87	70	17	41	44
Cranston Sewage Sludge									
Digested (1971)									
a	11	22	150	45	4	1	5	1	8
b	97	87	0	67	40	52	65	53	60
c	--	--	---	--	56	47	30	46	32

* $a = (\text{EDTA}/\text{total}) \times 100\% = \text{EDTA extracted monomers as \% of total.}$

b = $(\text{EDTA} + \text{HCl})/\text{total} \times 100\% - a = \text{EDTA extracted polymers as \% of total.}$

c = $100\% - (a + b) = \text{EDTA-nonextracted residue as \% of total.}$

** = treated with cold conc. H_2SO_4 followed by dilution to 1.3 M for further hydrolysis.

*** --- = Concentration is less than other extracts.

() = No. of samples represented.

TABLE III-2

CARBOHYDRATE COMPOSITION OF PLANKTON

(MOLE %)

Sugar:	Rh	Fu	Ri	A	X	M	Ga	Gl	Total (μ moles/g)
<u>Cariaco Trench</u>									
HCl	7.4	7.8	4.9	2.1	5.7	15.0	39.7	17.3	144.9
EDTA + HCl	8.3	13.9	6.8	5.6	7.3	11.3	25.8	21.1	59.2
EDTA	5.7	21.6	23.3	10.6	9.2	3.4	14.5	11.7	28.3
<u>Off Iceland</u>									
HCl	2.7	6.2	37.4	2.5	3.2	16.0	16.8	15.3	113.1
<u>Walvis Bay</u>									
HCl	3.0	4.2	2.8	.5	4.3	7.5	12.2	65.6*	217.9
<u>Pacific, Humboldt Current</u>									
1a HCl	4.0	3.0	14.8	3.0	3.7	13.1	18.0	40.5	40.5
7a HCl	5.1	7.1	7.1	6.0	19.4	13.2	22.5	19.4	44.8
15a HCl	5.9	9.7	5.6	2.9	9.0	16.0	35.9	14.9	44.3
<u>Lake Kivu</u>									
HCl	7.1	5.4	-	5.7	9.1	15.6	14.6	42.5	269.7
<u>Off Bermuda, 32N, 64W</u>									
HCl	4.6	6.4	5.6	1.1	5.5	11.9	37.3	27.6	86.9
<u>Oyster Pond, Woods Hole</u>									
HCl	5.4	6.3	22.1	.8	6.0	18.0	23.8	17.7	113.2
EDTA, HCl	6.3	8.8	28.0	.6	3.7	11.9	22.4	18.3	68.2
EDTA	2.2	9.9	35.9	.1	3.9	3.3	29.9	14.7	33.4
H ₂ O	-	-	25.9	-	9.3	5.7	-	59.3	5.4

* Cellulose fiber contamination present.

TABLE III-3

CARBOHYDRATE COMPOSITION OF PLANKTON(μ moles/g)

Sugar :	Rh	Fu	Ri	A	X	M	Ga	Gl	Total
<u>Cariaco Trench</u>									
HCl	10.7	11.3	7.1	3.1	8.3	21.8	57.5	25.1	144.9
EDTA + HCl	4.9	8.2	4.0	3.3	4.3	6.7	15.3	12.5	59.2
EDTA	1.6	6.1	6.6	3.0	2.6	1.0	4.1	3.3	28.3
<u>Off Iceland</u>									
HCl	.4	.8	4.9	.33	.42	2.1	2.2	2.0	13.1
<u>Walvis Bay</u>									
HCl	6.5	9.1	6.0	1.1	9.3	16.3	26.6	143.0*	217.9
<u>Pacific, Humboldt Current</u>									
1a HCl	1.6	1.2	6.0	1.2	1.5	5.3	7.3	16.4	40.5
7a HCl	2.3	3.2	3.2	2.7	8.7	5.9	10.1	8.7	44.8
15a HCl	2.6	4.3	2.5	1.3	4.0	7.1	15.9	6.6	44.3
<u>Lake Kivu</u>									
HCl	19.1	14.5	Tr	15.3	24.6	42.2	39.3	114.7	269.7
<u>Off Bermuda, 32N, 64W</u>									
HCl	4.0	5.6	4.9	.9	4.8	10.3	32.4	24.0	86.9
<u>Oyster Pond, Woods Hole</u>									
HCl	6.1	7.1	25.0	.9	6.8	20.4	26.9	20.0	113.2
EDTA + HCl	4.3	6.0	19.1	.4	2.5	8.1	15.3	12.5	68.2
EDTA	.73	3.3	12.0	.04	1.3	1.1	10.0	4.9	33.4
H ₂ O xt.	Tr	Tr	1.4	Tr	.5	.3	Tr	3.2	5.4

* Cellulose fiber contamination present

TABLE III-4

CARBOHYDRATE COMPOSITION OF ORGANIC WASTE MATERIALS

(MOLE %)

Sugar :	Rh	Fu	Ri	A	X	M	Ga	Gl	Total (μ moles/g)
Cranston, R.I. Sewage Sludge <u>Primary</u> (1972) HCl	7.3	2.5	1.7	4.7	10.3	17.0	11.5	45.0	271.1
EDTA + HCl	11.7	3.7	3.0	8.3	1.8	8.2	17.5	45.9	127.1
EDTA	7.1	7.7	12.5	45.8	2.8	2.6	6.5	14.9	16.8
Cranston, R.I. Sewage Sludge <u>Digested</u> (1972) HCl	12.1	3.2	2.4	7.2	14.0	24.3	14.5	22.2	187.1
EDTA + HCl	18.2	5.4	2.6	12.4	3.2	13.2	21.6	23.5	104.0
EDTA	8.5	11.0	20.6	40.7	2.7	4.5	9.5	2.2	19.9
Cranston, R.I. Sewage Sludge <u>Digested</u> (1971) HCl	11.2	2.9	.7	6.6	11.6	24.4	18.6	24.0	258.0
EDTA + HCl	17.7	4.7	1.5	10.9	7.8	19.0	19.3	19.0	175.4
EDTA	16.2	8.6	13.6	38.4	5.4	3.4	11.1	3.4	19.8
Deer Island, MA. Sewage Sludge <u>Primary</u> , HCl	3.1	1.0	.4	6.9	26.5	25.3	13.6	23.3	276.7
Conc. H_2SO_4	-	-	-	.7	7.7	8.6	.8	82.2	695.8
EDTA + HCl	5.3	2.0	1.1	16.3	15.4	11.3	22.3	26.5	117.3
EDTA	4.0	3.8	3.0	48.3	15.5	3.3	12.3	10.0	40.0
H_2O	-	-	6.6	6.6	-	-	-	87.3	1.0
Deer Island, MA. Sewage Sludge <u>Digested</u> , HCl	5.1	1.4	.4	9.1	21.7	20.3	15.9	26.1	152.7
Conc. H_2SO_4	3.2	.5	-	3.3	4.8	11.9	6.0	70.2	167.7

TABLE III-4 continued

CARBOHYDRATE COMPOSITION OF ORGANIC WASTE MATERIALS

Sugar:	<u>(MOLE %)</u>								Total (μ moles/g)
	Rh	Fu	Ri	A	X	M	Ga	Gl	
EDTA + HCl	9.2	3.1	1.2	16.9	16.6	13.2	22.9	16.9	128.5
EDTA	6.1	5.1	4.3	48.3	13.4	3.0	11.3	8.2	29.2
H ₂ O	-	-	25.5	52.9	-	21.6	-	-	.5

TABLE III-4 continued

CARBOHYDRATE COMPOSITION OF ORGANIC WASTE MATERIALS

Sugar	<u>(MOLE PERCENT)</u>								Total (μ moles/g)
	Rh	Fu	Ri	A	X	M	Ga	GI	
N. Y. Bight Buoy Sta. HCl	9.1	8.1	1.6	8.6	12.9	15.1	21.5	23.1	18.6
EDTA + HCl	10.8	10.8	2.5	10.8	12.5	12.5	22.5	17.5	12.0
EDTA	6.7	14.4	9.2	21.5	21.5	3.5	17.8	5.4	4.04
N. Y. Bight Mid-Gully HCl	9.5	8.3	4.1	7.3	10.3	16.7	22.7	21.2	6.6
N. Y. Bight, Deep Gully HCl	10.0	8.0	2.5	7.3	10.8	15.1	23.7	22.6	9.3
EDTA + HCl	12.4	12.9	6.1	8.3	12.2	10.4	22.6	15.1	5.9
Cow Manure: HCl	2.7	.4	-	13.6	61.0	2.3	5.5	14.5	1376.4
EDTA + HCl	4.4	.3	-	25.7	47.6	.9	10.0	11.1	499.5
EDTA	1.8	1.8	-	75.0	12.8	.8	6.1	1.6	110.1
H ₂ O	-	-	16.5	13.5	70.0	-	-	-	2.0

TABLE III-5

CARBOHYDRATE COMPOSITION OF ORGANIC WASTE MATERIALS(μ moles/g)

Sugar	Rh	Fu	Ri	A	X	M	Ga	Gl	Total
Cranston, R.I. Sewage Sludge Primary (1972) HCl	19.7	6.7	4.7	12.7	28.0	46.1	31.1	122.1	271.1
EDTA + HCl	14.9	4.7	3.8	10.5	2.3	10.4	22.2	58.3	127.1
EDTA	1.2	1.3	2.1	7.7	.5	.5	1.1	2.5	16.8
Cranston, R.I. Sewage Sludge Digested (1972) HCl	22.7	6.0	4.4	13.5	26.2	45.5	27.2	41.6	187.1
EDTA + HCl	18.9	5.6	2.7	12.9	3.3	13.7	22.5	24.4	104.0
EDTA	1.7	2.2	4.1	8.1	.5	.9	1.9	.4	19.9
Cranston, R.I. Sewage Sludge Digested (1971) HCl	28.8	7.6	1.8	17.0	29.8	62.9	48.1	62.0	258.0
EDTA + HCl	31.1	8.3	2.7	19.1	13.1	33.3	33.9	33.3	175.4
EDTA	3.2	1.7	2.7	7.6	1.1	.7	2.2	.7	19.8
Deer Island, MA. Sewage Sludge Primary HCl	8.5	2.9	1.0	19.0	73.3	69.9	37.7	64.4	276.7
Conc. H ₂ SO ₄	Tr	Tr	Tr	5.0	53.3	60.0	5.8	571.7	695.8
EDTA + HCl	6.2	2.3	1.3	19.1	18.1	13.2	26.1	31.1	117.3
EDTA	1.6	1.5	1.2	19.3	6.2	1.3	4.9	4.0	40.0
H ₂ O	Tr	Tr	.07	.07	Tr	Tr	Tr	Tr	1.0

TABLE III-5 continued

CARBOHYDRATE COMPOSITION OF ORGANIC WASTE MATERIALS(μ moles/g)

Sugar	Rh	Fu	Rf	A	X	M	Ga	GI	Total
Deer Island, MA. Sewage Sludge Digested HCl	7.8	2.1	.67	13.9	33.1	31.0	24.3	39.8	152.7
Conc. H ₂ SO ₄	5.4	.85	Tr	5.6	8.1	20.0	10.0	117.7	167.7
EDTA + HCl	11.8	4.0	1.6	21.7	21.3	17.0	29.4	21.7	128.5
EDTA	1.8	1.5	1.3	14.1	3.9	.89	3.3	2.4	29.2
H ₂ O	Tr	Tr	.13	.27	Tr	.11	Tr	Tr	.51
N. Y. Bight Byoy Sta. HCl	1.7	1.5	.30	1.6	2.4	2.8	4.0	4.3	18.6
EDTA + HCl	1.3	1.3	.30	1.3	1.5	1.5	2.7	2.1	12.0
EDTA	.27	.58	.37	.87	.87	.14	.72	.22	4.04
N. Y. Bight Mid-Gully HCl	.63	.55	.27	.48	.68	1.1	1.5	1.4	6.6
N. Y. Bight Deep Gully HCl	.93	.74	.23	.68	1.0	1.4	2.2	2.1	9.3
EDTA + HCl	.73	.76	.36	.49	.72	.61	1.33	.89	5.9

Cont.....

TABLE III-5 (Cont.)

Sugar	Rh	Fu	Ri	A	X	M	Ga	GI	Total
Cow Manure: HCl	37.5	6.0	Tr	187.4	839.3	31.1	75.4	199.7	1376.4
EDTA + HCl	21.9	1.3	Tr	128.6	237.8	4.4	50.0	55.5	499.5
EDTA	2.0	2.0	Tr	82.6	14.1	.89	6.7	1.8	110.1
H ₂ O	Tr	Tr	.33	.27	1.4	Tr	Tr	Tr	2.0

TABLE III-6
CARBOHYDRATE COMPOSITION OF CARIACO TRENCH SEDIMENT:

Sugar	Rh	Fu	MOLE % HCl xt.					Ga	GI	Total (μ moles/g)
			R1	A	X	M				
.15-.20 m	11.0	8.0	4.2	5.9	10.1	19.4	27.0	13.9	23.7	
.60-.64 m	10.9	12.4	3.1	4.9	9.8	18.1	27.9	12.4	19.3	
.64-.68 m Wood-HCl	6.5	1.8	Tr	15.1	23.1	4.4	13.7	35.4	258.9	
.64-.68 m Wood Conc. H ₂ SO ₄	3.9	.73	Tr	7.0	12.5	2.6	7.6	65.7	422.2	
1.0-1.05 m	10.3	8.2	4.1	5.2	10.3	17.9	29.3	14.6	18.4	
1.30-1.35 m	11.8	8.9	3.5	5.1	6.1	20.0	28.9	15.6	13.5	
1.75-1.80 m	12.0	9.5	3.2	4.9	10.2	21.9	26.4	12.1	9.1	
2.40 m	11.2	8.7	2.7	5.2	10.6	18.6	29.2	13.7	16.1	
2.65 m	10.8	7.6	2.8	7.3	11.7	18.7	28.1	12.9	6.4	
2.65 m (repeat)	11.4	8.0	3.3	5.2	12.1	16.7	27.3	12.5	6.2	
10 m	11.0	8.8	2.9	5.7	11.0	20.0	27.0	14.0	10.0	
40 m	10.1	8.5	3.7	7.0	10.4	17.9	29.8	12.4	6.7	
67 m	8.9	4.4	.5	10.0	12.2	25.6	22.2	17.8	2.7	
130 m	8.9	5.1	.8	9.8	12.3	22.1	24.3	16.6	2.4	

Sugar	Rh	Fu	HYDROLYZED EDTA XT.					Ga	GI	Total (μ moles/g)
			R1	A	X	M				
.15-.20 m	12.2	14.6	7.4	7.3	9.6	10.9	28.0	10.1	8.2	
.60-.64 m	12.0	13.3	7.7	7.3	11.2	10.7	26.5	11.8	8.3	
.64-.68 m Wood-EDTA	10.8	4.9	.6	44.9	18.8	2.0	15.1	2.9	65.5	
1.0-1.05 m	13.3	16.9	3.3	7.1	10.4	12.2	29.1	8.0	5.5	
1.30-1.35 m	13.6	16.1	4.2	7.5	6.9	7.2	27.8	16.9	3.6	
1.75-1.80 m	15.2	15.5	7.1	6.7	13.1	9.8	22.6	10.1	3.0	
2.40 m	12.4	12.7	7.9	7.9	12.4	10.0	27.0	9.4	6.7	
2.65 m	13.3	10.7	4.5	7.5	13.6	13.6	24.3	12.5	3.8	
10 m	11.4	13.7	5.6	7.4	12.8	11.4	27.9	10.9	4.3	
40 m	15.2	11.9	2.4	8.1	11.6	12.6	28.1	11.6	3.1	
67 m	11.6	5.1	1.8	6.4	15.1	21.9	23.3	15.1	.73	
130 m	13.6	8.3	1.5	8.3	14.8	15.9	21.6	15.9	.88	

TABLE III-6 continued

CARBOHYDRATE COMPOSITION OF CARIACO TRENCH SEDIMENT(MOLE %)UNHYDROLYZED EDTA XT

Sugar	Rh	Fu	Ri	A	X	M	Ga	Gl	Total (μ moles/g)
.15-.20 m	6.4	15.8	30.3	12.4	12.1	2.7	19.4	.7	3.3
.60-.64 m	7.0	20.0	28.3	10.4	14.3	1.4	17.4	1.0	2.3
.64-.68 m Wood-EDTA ext.	4.3	4.6	-	54.9	21.7	.9	11.0	2.5	63.0
.64-.68 m Wood-H ₂ O ext.	-	-	-	-	-	-	-	-	0
1.0-1.05 m	n.d.	n.d.	n.d.	n.d.	n.d.	n.d.	n.d.	n.d.	n.d.
1.30-1.35 m	7.9	13.6	16.4	11.4	9.3	2.4	27.9	8.6	1.4
1.75-1.80 m	n.d.	n.d.	n.d.	n.d.	n.d.	n.d.	n.d.	n.d.	n.d.
10 m	8.5	18.3	17.6	13.1	16.3	4.4	24.8	5.1	1.5
40 m	10.0	15.4	13.2	14.3	14.3	5.5	24.2	3.1	.91
67 m	10.9	13.6	3.2	9.1	21.4	7.7	20.0	15.0	.22
130 m	7.7	10.0	4.2	10.6	28.1	14.2	19.7	7.1	.31

TABLE III-7

CARBOHYDRATE COMPOSITION OF CARIACO TRENCH SEDIMENT: ($\mu\text{moles/g}$)

Sugars	HCl XT.								Total
	Rh	Fu	Rl	A	X	M	Ga	G1	
.15-.20 m	2.6	1.9	1.1	1.4	2.4	4.6	6.4	3.3	23.7
.60-.64 m	2.1	2.4	.60	.95	1.9	3.5	5.4	2.4	19.3
.64-.68 m Wood - HCl	16.8	4.6	tr	39.2	59.9	11.4	35.4	91.6	258.9
.64-.68 m Wood-Conc. H ₂ SO ₄	16.3	3.1	-	29.5	52.8	11.1	31.9	277.5	422.2
1.00-1.05 m	1.9	1.5	.75	.96	1.9	3.3	5.4	2.7	18.4
1.30-1.35 m	1.6	1.2	.47	.69	.83	2.7	3.9	2.1	13.5
1.75-1.80 m	1.1	.87	.29	.45	.93	2.0	2.4	1.1	9.1
2.40 m	1.8	1.4	.34	.57	1.7	3.0	4.7	2.2	16.1
2.65 m	.69	.49	.18	.47	.75	1.2	1.8	.83	6.4
2.65 m (repeat)	.71	.50	.27	.51	.75	1.0	1.7	.78	6.2
10 m	1.1	.88	.29	.57	1.1	2.0	2.7	1.4	10.0
40 m	.68	.57	.25	.47	.70	1.2	2.0	.83	6.7
67 m	.24	.12	.013	.27	.33	.69	.60	.48	2.7
130 m	.21	.12	.020	.23	.29	.52	.57	.39	2.35
HYDROLYZED EDTA XT.									
.15-.20 m	1.0	1.2	.61	.60	.79	.89	2.3	.83	8.2
.60-.64 m	1.0	1.1	.64	.61	.93	.89	2.2	.98	8.3
.64-.68 m Wood	7.1	3.2	.39	29.4	12.3	1.3	9.9	1.9	65.5
1.00-1.05 m	.73	.93	.18	.39	.57	.67	1.6	.44	5.5
1.30-1.35 m	.49	.58	.15	.27	.25	.26	1.0	.61	3.6
1.75-1.80 m	.45	.46	.21	.20	.39	.29	.67	.30	3.0
2.40 m	.83	.85	.53	.53	.83	.67	1.8	.63	6.7
2.65 m	.50	.40	.17	.28	.51	.51	.91	.47	3.8
10 m	.49	.56	.24	.32	.55	.49	1.2	.47	4.3
40 m	.47	.37	.073	.25	.36	.39	.87	.36	3.1
67 m	.085	.037	.013	.047	.11	.16	.17	.11	.73
130 m	.12	.073	.013	.073	.13	.14	.19	.14	.88

TABLE III-7 continued

CARBOHYDRATE COMPOSITION OF CARIACO TRENCH SEDIMENT: (μ moles/g)UNHYDROLYZED EDTA XT

Sugar:	Rh	Fu	Ri	A	X	M	Ga	Gl	Total
.15-.20 m	.21	.52	1.0	.41	.40	.09	.64	.02	3.3
.60-.64 m	.16	.46	.65	.24	.33	.03	.40	.02	2.3
.64-.68 m Wood	2.7	2.9	-	34.6	13.7	.56	6.9	1.6	63.0
.64-.68 m Wood H ₂ O extract	-	-	-	-	-	-	-	-	0
1.00-1.05 m	n.d.	n.d.	n.d.	n.d.	n.d.	n.d.	n.d.	n.d.	n.d.
1.30-1.35 m	.11	.19	.23	.16	.13	.03	.39	.12	1.4
1.75-1.80 m	n.d.	n.d.	n.d.	n.d.	n.d.	n.d.	n.d.	n.d.	n.d.
10 m	.13	.28	.27	.20	.25	.07	.38	.08	1.53
40 m	.091	.14	.12	.13	.13	.05	.22	.03	.91
67 m	.02	.03	.01	.02	.05	.02	.04	.03	.22
130 m	.02	.03	.01	.03	.09	.04	.06	.02	.31

TABLE III-8

CARBOHYDRATE COMPOSITION OF SEDIMENT FROM ARGENTINE BASIN,
BERMUDA AND BLAKE PLATEAU (MANGANESE NODULE)

(MOLE %)

Sugar:	Rh	Fu	Ri	A	X	M	Ga	Gl	Total (μ moles/g)
<u>ARGENTINE BASIN</u>									
0 cm HCl	8.8	8.1	6.2	10.2	9.5	13.7	23.7	19.9	4.2
0 cm EDTA + HCl	10.1	9.5	8.9	8.9	13.1	12.5	24.3	12.8	3.4
5 cm HCl	8.1	10.1	4.9	11.5	10.1	12.2	23.6	19.6	1.5
5 cm EDTA + HCl	8.3	11.9	6.7	10.1	11.0	11.9	23.8	16.5	1.1
15 cm HCl	8.5	9.1	3.2	9.1	9.8	13.9	24.9	21.4	3.2
15 cm EDTA + HCl	10.7	12.0	5.4	8.7	10.7	12.0	25.2	15.3	2.4
60 cm HCl	9.0	9.7	4.7	10.3	11.2	13.7	24.3	17.1	3.2
60 cm EDTA + HCl	11.6	12.6	6.3	8.7	12.6	11.6	23.2	13.5	2.1
100 cm HCl	8.7	9.3	4.3	10.6	10.3	14.1	23.9	18.8	3.7
100 cm EDTA + HCl	10.4	11.6	2.7	8.4	11.6	11.6	26.9	16.5	2.5
100 cm EDTA	7.9	15.0	15.0	15.0	16.0	4.4	18.0	8.3	1.0
300 cm HCl	9.0	10.2	5.6	9.8	10.9	13.5	23.3	16.5	2.6
300 cm EDTA + HCl	10.2	12.9	3.6	8.1	9.7	14.5	25.3	16.7	1.9
500 cm HCl	6.7	10.5	5.0	9.6	12.0	14.9	25.4	15.8	3.4
500 cm EDTA + HCl	10.2	13.2	6.3	8.3	12.2	12.2	26.8	10.7	2.1
500 cm EDTA	9.5	16.7	15.6	13.5	14.6	5.2	16.7	8.6	1.0

TABLE III-8 continued

CARBOHYDRATE COMPOSITION OF SEDIMENT FROM ARGENTINE BASIN,
BERMUDA AND BLAKE PLATEAU (MANGANESE NODULE)

(MOLE %)

<u>Bermuda, Surface HCl</u>	10.7	9.8	4.1	8.9	12.6	16.8	23.8	13.1	2.1
<u>Mn Nodule EDTA, HCl</u>	9.5	10.7	-	6.2	12.9	9.8	18.8	31.8	.085

TABLE III-9

CARBOHYDRATE COMPOSITION OF SEDIMENT FROM ARGENTINE BASIN,
BERMUDA, AND BLAKE PLATEAU (MANGANESE NODULE)

(μ moles/g)

Sugars:	Rh	Fu	Ri	A	X	M	Ga	Gl	Total
<u>ARGENTINE BASIN</u>									
0 HCl	.37	.34	.26	.43	.40	.58	1.0	.84	4.22
0 EDTA + HCl	.34	.32	.30	.30	.44	.42	.82	.43	3.37
5 HCl	.12	.15	.07	.17	.15	.18	.35	.29	1.48
5 EDTA + HCl	.09	.13	.07	.11	.12	.13	.26	.18	1.09
15 HCl	.27	.29	.10	.29	.31	.44	.79	.68	3.17
15 EDTA + HCl	.26	.29	.13	.21	.26	.29	.61	.37	2.42
60 HCl	.29	.31	.15	.33	.36	.44	.78	.55	3.21
60 EDTA + HCl	.24	.26	.13	.18	.26	.24	.48	.28	2.07
100 HCl	.32	.34	.16	.39	.38	.52	.88	.69	3.68
100 EDTA + HCl	.26	.29	.07	.21	.29	.29	.67	.41	2.49
100 EDTA	.08	.15	.15	.15	.16	.04	.18	.08	1.00
300 HCl	.24	.27	.15	.26	.29	.36	.62	.44	2.63
300 EDTA + HCl	.19	.24	.07	.15	.18	.23	.47	.31	1.86
500 HCl	.23	.36	.17	.33	.41	.51	.87	.54	3.42
500 EDTA + HCl	.21	.27	.13	.17	.25	.25	.55	.22	2.05
500 EDTA	.09	.16	.15	.13	.14	.05	.16	.08	.96
<u>Bermuda</u> HCl	.23	.21	.09	.19	.27	.36	.51	.28	2.14
<u>Mn Nodule, Blake Plateau</u>									
EDTA + HCl	.008	.009	-	.005	.011	.008	.016	.027	.085

TABLE III-10

CARBOHYDRATE COMPOSITION OF SEDIMENT FROM LAKE KIVU,
WALVIS BAY AND OYSTER POND

(MOLE %)

Sugar	Rh	Fu	Ri	A	X	M	Ga	Gl	Total (μ moles/g)
<u>Lake Kivu</u>									
125 cm HCl St. 10, 1971	5.3	3.0	.5	2.9	3.7	5.3	36.9	42.5	195.9
125 cm EDTA + HCl	10.0	5.5	.7	6.1	6.9	7.2	38.8	24.7	72.2
125 cm EDTA	7.1	7.8	1.9	10.3	8.5	.8	59.2	4.3	28.2
240 cm HCl St. 10, 1971	13.0	11.1	-	7.7	12.6	13.5	17.3	24.8	63.7
240 cm EDTA + HCl	18.6	12.8	-	9.5	10.7	11.9	13.7	22.9	32.8
240 cm EDTA	19.6	22.9	3.5	19.4	15.2	2.0	13.5	2.9	4.8
530 cm HCl St. 4, 1972	11.1	5.6	1.2	6.5	12.9	15.7	21.2	25.8	10.8
530 cm EDTA + HCl	14.1	9.2	9.8	7.3	8.2	14.4	21.7	15.2	3.7
530 cm EDTA	11.7	13.3	9.4	13.3	14.8	6.2	21.9	9.4	1.3
930 cm HCl St. 4, 1972	9.7	7.2	.8	6.7	10.6	17.7	22.4	24.8	8.5
930 cm EDTA + HCl	10.1	14.9	1.7	6.9	9.4	13.8	26.4	16.7	2.8
930 EDTA	10.2	15.7	4.6	9.3	15.7	9.3	25.9	9.3	1.1

TABLE III-10 continued

CARBOHYDRATE COMPOSITION OF SEDIMENT FROM LAKE KIVU,
WALVIS BAY AND OYSTER POND
(MOLE %)

Walvis Bay

HCl	15.7	12.7	2.3	6.1	9.4	8.2	26.9	18.6	81.7
EDTA + HCl	16.6	10.8	3.8	5.4	11.5	12.4	24.5	15.0	31.4
EDTA	11.3	18.1	15.9	12.5	17.0	3.6	19.3	2.4	8.8

Oyster Pond

HCl	11.1	6.8	.9	10.2	11.3	13.3	20.2	26.1	81.1
EDTA + HCl	13.6	10.3	2.0	15.0	12.5	9.5	21.4	15.6	35.9
EDTA	9.9	15.6	5.2	32.3	16.2	2.7	15.0	3.7	8.7

TABLE III-11

CARBOHYDRATE COMPOSITION OF SEDIMENT FROM LAKE KIVU,
WALVIS BAY AND OYSTER POND

(μ moles/g)

Sugars:	Rh	Fu	Ri	A	X	M	Ga	Gl	Total
<u>Lake Kivu</u>									
125 cm HCl St. 10, 1971	10.3	5.8	1.0	5.7	7.2	10.4	72.2	83.3	195.9
125 cm EDTA + HCl	7.3	4.0	.5	4.4	5.0	5.2	28.0	17.8	72.2
125 cm EDTA	2.0	2.2	.5	2.9	2.4	.2	16.7	1.2	28.2
240 cm HCl St. 10, 1971	8.3	7.1	Tr	4.9	8.0	8.6	11.0	15.8	63.7
240 cm EDTA + HCl	6.1	4.2	Tr	3.1	3.5	3.9	4.5	7.5	32.8
240 EDTA	.94	1.1	.17	.93	.73	.10	.65	.14	4.8
530 cm HCl St. 4, 1972	1.2	.61	.13	.70	1.4	1.7	2.3	2.8	10.8
530 cm EDTA + HCl	.52	.34	.36	.27	.30	.53	.80	.56	3.68
530 cm EDTA	.15	.17	.12	.17	.19	.08	.28	.12	1.28
930 cm HCl St. 4, 1972	.82	.61	.07	.57	.90	1.5	1.9	2.1	8.47
930 cm EDTA + HCl	.28	.41	.05	.19	.26	.38	.73	.46	2.76
930 cm EDTA	.11	.17	.05	.10	.17	.10	.28	.10	1.08
<u>Walvis Bay: Surface</u>									
HCl	12.8	10.4	1.9	5.0	7.7	6.7	22.0	15.2	81.7
EDTA + HCl	5.2	3.4	1.2	1.7	3.6	3.9	7.7	4.7	31.4
EDTA	1.0	1.6	1.4	1.1	1.5	.3	1.7	.2	8.8

TABLE III-11 continued

CARBOHYDRATE COMPOSITION OF SEDIMENT FROM LAKE KIVU,
WALVIS BY AND OYSTER POND

(μ moles/g)

Oyster Pond: Surface

HCl	9.0	5.5	.72	8.3	9.2	10.8	16.4	21.2	81.1
EDTA + HCl	4.9	3.7	.72	5.4	4.5	3.4	7.7	5.6	35.9
EDTA	.86	1.3	.45	2.8	1.4	.23	1.3	.32	8.7

TABLE III-12

CARBOHYDRATE COMPOSITION OF BLACK SEA SEDIMENT(MOLE %)

Sugar	Rh	Fu	Ri	A	X	M	Ga	Gl	Total (μ moles/g)
15 cm HCl	4.8	7.6	9.6	4.6	16.3	23.7	20.0	13.3	45.9
15 cm EDTA + HCl	11.9	12.4	10.3	7.0	10.3	10.8	26.5	10.8	18.5
15 cm EDTA	3.5	14.2	33.3	9.6	19.3	1.5	17.5	1.2	5.7
65-70 cm HCl	15.1	10.9	5.5	8.9	12.6	10.0	18.3	18.8	250.8
65-70 cm EDTA + HCl	19.3	13.0	5.5	6.8	14.0	8.7	15.6	17.0	137.5
65-70 cm EDTA	14.9	15.9	21.1	9.6	19.2	1.4	15.9	2.2	51.1
120-130 cm HCl	12.5	6.3	1.8	10.4	10.0	14.6	22.9	21.9	9.6
120-130 cm EDTA + HCl	15.5	11.8	4.3	11.2	11.2	12.6	18.5	15.4	6.5
120-130 cm EDTA	12.3	11.5	10.0	24.6	10.8	3.4	18.5	5.5	1.3
120-130 H ₂ O	-	-	-	-	-	-	-	-	-
120-130 cm H ₂ O + HCl	19.7	16.7	2.0	7.1	8.0	6.7	13.5	27.8	.66
120-130 cm H ₂ O + EDTA	23.9	16.7	-	33.3	7.2	-	6.1	12.2	.18

TABLE III-13

CARBOHYDRATE COMPOSITION OF BLACK SEA SEDIMENT(μ moles/g)

Sugars:	Rh	Fu	Ri	A	X	M	Ga	Gl	Total
15 cm HCl	2.2	3.5	4.4	2.1	7.5	10.9	9.2	6.1	45.9
15 cm EDTA + HCl Extract	2.2	2.3	1.9	1.3	1.9	2.0	4.9	2.0	18.5
15 cm EDTA extract	.2	.81	1.9	.55	1.1	.08	1.0	.07	5.7
65-70 cm HCl	37.9	27.4	13.7	22.2	31.6	25.0	45.8	47.2	250.8
65-70 EDTA + HCl Extract	26.5	17.9	7.5	9.4	19.3	11.9	21.5	23.4	137.5
65-70 EDTA Extract	7.6	8.1	10.8	4.9	9.8	.72	8.1	1.1	51.1
120-130 HCl	1.2	.60	.17	1.0	.96	1.4	2.2	2.1	9.6
120-130 EDTA + HCl Extract	1.0	.77	.28	.73	.73	.82	1.2	1.0	6.5
120-130 EDTA Extract	.16	.15	.13	.32	.14	.04	.24	.07	1.3
120-130 H ₂ O Extract	tr.	-	-	-	-	-	-	-	-
120-130 H ₂ O + HCl Extract	.13	.11	.01	.05	.05	.04	.09	.17	.66
120-130 H ₂ O + EDTA	.04	.03	-	.06	.01	-	.01	.02	.18

TABLE III-14

CARBOHYDRATE COMPOSITION OF SEDIMENT FROM SANTA BARBARA BASIN

(Off California)

SUGARS	Mole %								Total (umoles/g)
	Rh	Fu	Ri	A	X	M	Ga	G1	
~50 yrs., H ₂ SO ₄ after Modzeleski et al. (1971) H ₂ O insoluble	11.8	8.7	5.2	7.0	12.7	12.7	26.2	15.7	22.9
~50 yrs., HCl, H ₂ O in- soluble	10.2	8.0	4.9	6.8	11.7	15.9	25.8	16.7	26.4
~50 yrs., HCl, H ₂ O in- soluble + soluble	11.7	8.4	4.7	8.4	10.7	13.8	25.8	16.4	29.8
~50 yrs., EDTA + HCl	13.3	12.5	7.8	7.8	14.1	10.2	24.2	10.2	12.8
~50 yrs., H ₂ O soluble (Hydrolyzed)	16.6	12.2	2.2	4.4	10.5	14.9	28.2	11.0	3.6
~750 yrs., H ₂ SO ₄ after Modzeleski et al. (1971) H ₂ O insoluble	11.7	9.4	8.6	8.6	18.0	10.2	24.2	10.2	12.8
~750 yrs., HCl, H ₂ O insoluble	12.6	8.2	5.7	6.9	12.6	17.0	22.6	14.5	15.9
~750 yrs., HCl, H ₂ O insoluble + soluble	11.8	8.1	4.3	5.2	11.8	16.6	26.1	16.1	21.1
~750 yrs., H ₂ O soluble (Hydrolyzed)	16.3	14.0	3.9	3.9	10.1	14.7	24.8	12.4	2.6

TABLE III-15

CARBOHYDRATE COMPOSITION OF SEDIMENT FROM SANTA BARBARA BASIN

(Off California)

SUGARS	<u>μ moles/g</u>								
	Rh	Fu	Ri	A	X	M	Ga	GI	Total
~50 yrs., H ₂ SO ₄ after Modzeleski et al. (1971) H ₂ O insoluble	2.7	2.0	1.2	1.6	2.9	2.9	6.0	3.6	22.9
~50 yrs., HCl, H ₂ O insoluble	2.7	2.1	1.3	1.8	3.1	4.2	6.8	4.4	26.4
~50 yrs., HCl, H ₂ O insoluble + soluble	3.5	2.5	1.4	2.5	3.2	4.1	7.7	4.9	29.8
~50 yrs., EDTA + HCl	1.7	1.6	1.0	1.0	1.8	1.3	3.1	1.3	12.8
~50 yrs., H ₂ O Soluble (Hydrolyzed)	.60	.44	.08	.16	.38	.54	1.02	.40	3.6
~750 yrs., H ₂ SO ₄ after Modzeleski et al. (1971) H ₂ O insoluble	1.5	1.2	1.1	1.1	2.3	1.3	3.1	1.3	12.8
~750 yrs., HCl, H ₂ O insoluble	2.0	1.3	.9	1.1	2.0	2.7	3.6	2.3	15.9
~750 yrs., HCl, H ₂ O insoluble + soluble	2.5	1.7	.9	1.1	2.5	3.5	5.5	3.4	21.1
~750 yrs., H ₂ O in- soluble (Hydrolyzed)	.41	.36	.10	.10	.26	.39	.64	.32	2.6

TABLE III-16

CARBOHYDRATE COMPOSITION OF ARGENTINE BASIN, LAKE KIVU,AND CARIACO TRENCH SEDIMENTS

Hydrolyzed EDTA xt.
(% of HCl xt.)

SUGAR	Rh	Fu	Ri	A	X	M	Ga	G1	Total (%)
Argentine Basin (cm)									
0	91	94	100	70	100	72	82	51	80
5	76	87	100	65	80	72	74	62	74
15	96	100	100	72	84	66	77	54	76
60	92	84	87	55	72	55	62	51	64
100	81	85	42	54	76	56	76	59	68
300	79	89	45	56	62	64	76	70	71
500	91	75	76	52	61	49	63	41	60
Average	85	87	72	60	75	61	72	54	70
Lake Kivu (cm)									
125	71	69	47	77	69	50	39	21	37
240	73	59	-	63	44	45	41	47	51
530	43	56	100	39	21	31	35	20	34
930	34	67	72	33	29	25	38	22	33
Average	50	63	77	48	33	36	38	24	37
Cariaco Trench (m)									
.15	38	63	56	43	33	19	36	25	34
.60	48	45	100	63	50	26	40	42	43
(wood) .64	42	71	-	77	20	11	28	24	16
1.00	38	63	24	40	30	20	29	16	30
1.30	30	48	32	38	30	19	26	29	26
1.80	41	53	72	44	42	15	28	27	33
2.40	46	61	100	63	49	22	38	29	42
(oxic) 2.65	72	82	100	57	68	46	52	59	60
10.0	45	63	83	56	50	24	43	33	43
40.0	71	67	29	53	53	32	43	43	45
67.0	36	31	100	18	33	23	29	23	27
130.0	56	63	67	31	45	27	33	34	37

TABLE III-17

CARBOHYDRATE COMPOSITION OF ARGENTINE BASIN, LAKE KIVU,AND CARIACO TRENCH SEDIMENTS

Unhydrolyzed EDTA xt.
(% of Hydrolyzed EDTA xt.)

SUGAR	Rh	Fu	Ri	A	X	M	Ga	G1	Total (%)
Argentine Basin (cm)									
100	30	52	100	71	55	15	27	20	40
500	43	59	100	76	56	20	29	38	47
Lake Kivu (cm)									
125	27	55	100	56	48	4	60	7	39
240	15	26	-	30	21	2	14	2	15
530	29	50	33	63	63	15	28	21	35
930	39	41	100	53	65	26	38	22	39
Cariaco Trench (m)									
.15	21	43	100	68	51	10	28	3	40
.60	16	42	100	39	35	4	18	2	28
(wood) .64	38	91	-	100	100	43	70	84	96
1.3	22	33	100	59	52	13	39	20	39
10	26	50	100	63	45	14	32	17	36
40	19	38	100	52	36	13	25	8	29
67	28	81	54	43	43	11	26	30	30
130	20	41	100	45	67	31	32	16	35

APPENDIX IV

GLOSSARY

APPENDIX IV

GLOSSARY

Carbohydrates: polyhydroxy aldehydes or polyhydroxy ketones, or substances that yield such compounds on hydrolysis.

Chitin: a polysaccharide similar in structure to cellulose except that an acetylamine group replaces a hydroxyl group:

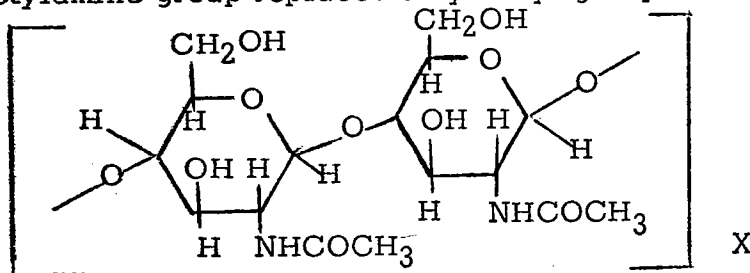

Chitin is found in the shells of crustacea and is the structural substance of insects and fungi; chitin is extremely resistant to biological and chemical degradation.

Disaccharides: carbohydrates which yield two molecules of monosaccharides on hydrolysis; e.g., maltose = 2 glucose; lactose = 1 glucose and 1 galactose; and sucrose = 1 glucose and 1 fructose.

Fulvic acid: derived from humus; alkali-soluble, acid-soluble fraction; it is composed of heterogeneous molecules and contains a high degree of functionality.

Humic acids: derived from humus; alkali-soluble, acid-insoluble fraction; it contains a lower degree of functionality and higher molecular weight range than fulvic acids.

Humus (or humic substances): acidic, yellow-to black-colored, moderately high molecular weight polymers which are composed of extremely heterogeneous mixtures of molecules (presumably of biological origin); the molecular weight range of humus in soils or sediments usually varies between 2000 and 300,000; humus has a considerably higher degree of functionality than kerogen, especially with respect to COOH and OH groups; humus is the major organic constituent of soils and sediments.

Kerogen: the major organic component of sedimentary rocks; kerogen is probably derived from the metamorphism of humus; kerogen contains a high degree of aromaticity and a low degree of functionality; this

high molecular weight polymeric substance is relatively inert and therefore requires drastic chemical means for its extraction and degradation.

Lignin: a polymeric structural constituent of woody tissue in vascular plants; it is not found in marine plants; lignin-related substances are major components of soil humus; alkaline hydrolysis of lignin dominantly yields various aromatic hydroxy-acids and aldehydes such as p-hydroxybenzaldehyde and vanillin.

Monosaccharides: carbohydrates that do not hydrolyze; the following monosaccharides have been discussed in the thesis:

1. pentoses: five-carbon sugars; hexoses: six-carbon sugars;
 - a. L - arabinose =

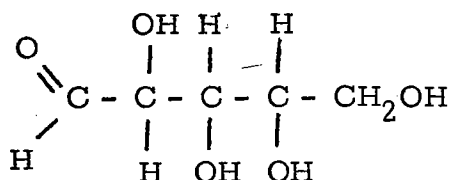

occurs widely in plants in both free and combined (in gums) forms; its function marine algae is unknown.

- b. D - xylose =

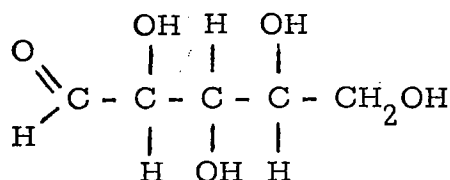

an all trans sugar; found in a combined form in woody materials; probably a component of structural polysaccharides; function in marine algae is unknown but might also be partial structural; xylose always appears fourth or fifth in the orders of abundance of sugars in sediments and plankton.

- c. D - ribose =

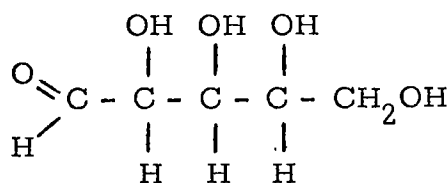

an all cis sugar; glycosidically linked to nitrogen compounds in nucleotides, several vitamins and coenzymes; this sugar may account for up to 40% of the total sugars in marine plankton; it is probably a much smaller fraction of the total sugars of terrigenous plants.

d. D - galactose =

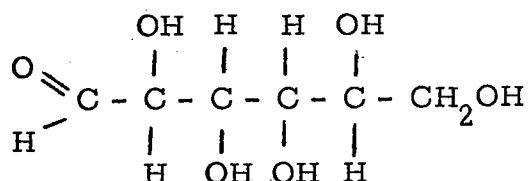

constituent of oligosaccharides (e.g., lactose and raffinose); also a major constituent of polysaccharides (e.g., agar and plant germs); the function in marine plankton is unknown, however, it is probably not incorporated into structural polysaccharides to any great degree.

e. D - fructose:

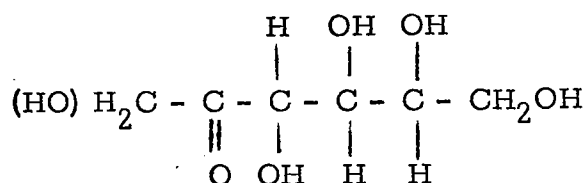

this keto sugar is principally found in terrigenous plants as a food storage product; it is called 'fruit sugar'; it is a constituent of the disaccharide, sucrose; fructose is not detected in either marine algae or marine sediment.

f. D - glucose =

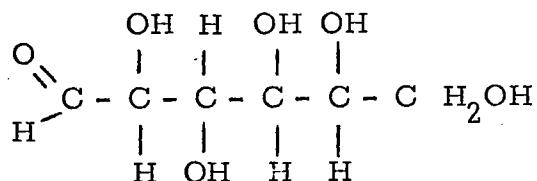

the commonest sugar of terrigenous plants; occurs in both free and combined forms; cellulose, the most important structural polysaccharide, is composed only of this sugar; starch, the major food storage polysaccharide, is also composed only of

Polysaccharides: carbohydrates that yield a large number of molecules of monosaccharides on hydrolysis; polysaccharides made up of only a single type of building unit are known as homopolysaccharides; cellulose is a good example of this type:

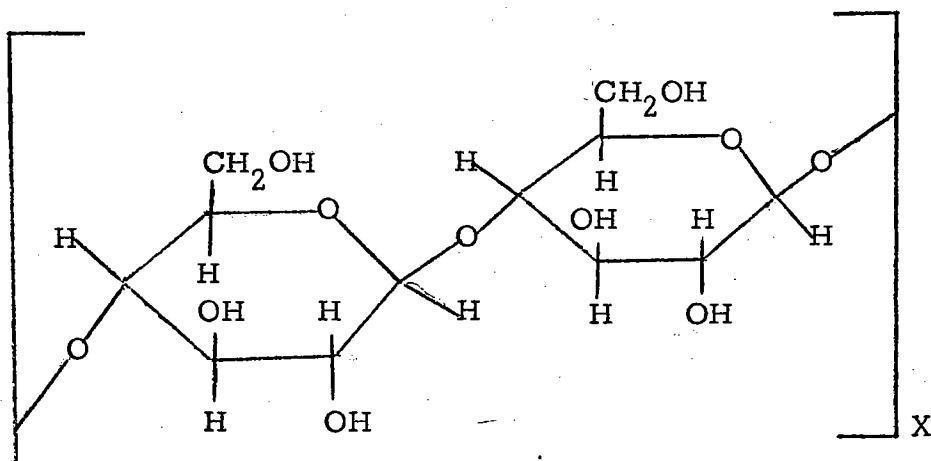

cellulose (β -glycosidic linkages in 1-4 positions)

polysaccharides that yield more than one kind of sugar on hydrolysis are called glycans; e.g., mannans (mostly mannose) and xylans (mostly xylose).