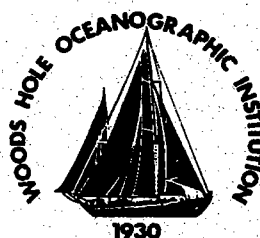


**WHOI-93-03**

*C.1*

# **Woods Hole Oceanographic Institution**



---

## **Feasibility Study of Non-Invasive Telemetry Techniques for Use With Submarine Telephone Cables**

by

Neil L. Brown, Daniel E. Frye and John Proakis

January 1993

## **Technical Report**

Funding was provided by the IRIS Consortium under sub-award agreement No. 0169 and by the W.M. Keck Foundation through their Technology Innovation Awards.

---

WHOI-93-03

**Feasibility Study of Non-Invasive Telemetry Techniques  
for  
Use With Submarine Telephone Cables**

by

Neil L. Brown and Daniel E. Frye  
Woods Hole Oceanographic Institution  
Woods Hole, Massachusetts 02543

and

John Proakis  
Northeastern University  
Boston, Massachusetts

January 1993

**Technical Report**



Funding was provided by the IRIS Consortium under sub-award agreement No. 0169 and by the W.M. Keck Foundation through their Technology Innovation Awards.

Reproduction in whole or in part is permitted for any purpose of the United States Government. This report should be cited as:  
Woods Hole Oceanog. Inst. Tech. Rept., WHOI-93-03.

Approved for publication; distribution unlimited.

**Approved for Distribution:**

A handwritten signature in cursive script that reads "George V. Frisk".

**George V. Frisk, Chairman**  
Department of Applied Ocean Physics  
and Engineering

## ***ABSTRACT***

The feasibility of using inductive coupling with existing submarine telephone cables for telemetry of data from ocean sensors was investigated. The submarine telephone cable was simulated with a computer model and the model results were tested experimentally by deploying 600 meters of coax cable in Woods Hole Harbor. In parallel a study of the optimum access methods and modulation and techniques was performed.

Results of the feasibility study showed that a non-invasive technique for inductive coupling is not feasible for use with existing SF and SD coaxial cable designs. Signals induced in both conductors by a toroid encircling the cable remain identical as they propagate along the cable as a result of mutual inductance. Thus, no signals are apparent at the repeaters. Optimal use of cable bandwidth combines time division multiple access with trellis-coded QAM modulation.

## **TABLE OF CONTENTS**

<b>EXECUTIVE SUMMARY</b> . . . . .	5
<b>1.0 INTRODUCTION</b> . . . . .	7
<b>2.0 COMPUTER MODEL OF SUBMARINE CABLE SYSTEM</b> . . . . .	8
<b>2.1 Effect of Skin Depth</b> . . . . .	10
<b>2.2 Computer Simulation</b> . . . . .	12
<b>3.0 EXPERIMENTAL VERIFICATION</b> . . . . .	13
<b>3.1 Experimental Results</b> . . . . .	13
<b>3.2 Additional Tests</b> . . . . .	17
<b>3.3 Conclusions</b> . . . . .	22
<b>4.0 BANDWIDTH UTILIZATION</b> . . . . .	22
<b>4.1 System Parameters for the SF Submarine Cable System</b> . . . . .	23
<b>4.2 Objectives of the System Design</b> . . . . .	25
<b>4.3 Multiple-Access Methods</b> . . . . .	25
<b>4.4 Modulation and Coding</b> . . . . .	28
<b>5.0 CONCLUSIONS AND RECOMMENDATIONS</b> . . . . .	36
<b>6.0 REFERENCES</b> . . . . .	38
<b>7.0 APPENDIX</b> . . . . .	39

## *LIST OF FIGURES*

<b>Figure 1</b>	Proposed inductive telemetry system . . . . .	9
<b>Figure 2</b>	Electrical model of SF cable system . . . . .	9
<b>Figure 3</b>	Experimental setup for testing skin depth hypothesis . . . . .	11
<b>Figure 4</b>	SF cable construction . . . . .	12
<b>Figure 5</b>	Experimental model of system . . . . .	14
<b>Figure 6a</b>	Simple model of a transmission line element . . . . .	16
<b>Figure 6b</b>	Model representation including mutual inductance effects . . . . .	16
<b>Figure 7</b>	Experimental configuration for inducing signal in the outer conductor only . . . . .	18
<b>Figure 8</b>	Experimental setup for the "dipole antenna" configuration . . . . .	20
<b>Figure 9</b>	Experimental setup for directly driving the outer conductor . . . . .	20
<b>Figure 10a</b>	Signal induced in a simple loop . . . . .	21
<b>Figure 10b</b>	Loop test with coaxial conductor . . . . .	21
<b>Figure 11</b>	M=8 PSK and QAM signal constellations . . . . .	29
<b>Figure 12</b>	Raised-cosine spectra . . . . .	30
<b>Figure 13</b>	Rectangular QAM signal constellations . . . . .	32
<b>Figure 14</b>	Block diagram of modulator for generating trellis-coded modulation signals . . . . .	34
<b>Figure 15</b>	Block diagram of demodulator for trellis-coded modulation signals . . . . .	34

## *LIST OF TABLES*

<b>Table 1</b>	Results of simulation for the in-water experiment .	14
<b>Table 2</b>	Attenuation as a function of frequency for a signal injected directly into the test cable (600m) . . . . .	15
<b>Table 3</b>	Attenuation of signals induced in the outer conductor after propagating 300m . . . . .	18

## *EXECUTIVE SUMMARY*

A feasibility study has been performed to investigate using non-invasive inductive telemetry techniques to couple ocean sensors to existing analog submarine telephone cables. The attraction of the idea is that "clamp-on" inductive modems (and associated ocean sensors) could be installed at points along the cable without the need for expensive cable ship operations which involve cable retrieval and re-deployment. The key questions to be answered by the study were:

- 1) Can signals be induced in the cable with sufficient SNR so that the existing repeater network can be used to transmit the signals to shore?
- 2) What level of power is required by the inductive device to generate these signals?
- 3) What communication techniques are best for using the bandwidth available in existing submarine cables?

To answer these questions a computer model simulating submarine cable performance was developed and a series of in-water experiments to test the model predictions was performed. In parallel, an analysis of bandwidth utilization was conducted. Unfortunately, the feasibility study provided a negative answer to question one. The in-water tests showed that it was not possible to induce (non-invasively) a signal between the inner and outer conductors of a submarine cable. A signal with respect to seawater ground could be induced in both the inner and outer conductors, but no difference between the conductors developed as the signal propagated; thus there is no signal for the repeater to amplify. In short, the non-invasive technique is not feasible. If, through other techniques, signals are injected into the cable, the results determined for questions 2 and 3 suggest that very high data rates are possible using very low power transmitters. Data rates for an SF cable system of 6 Mbps could be maintained with an energy input into the line of the

order of one watt per modem. Optimal use of the cable bandwidth uses a system which combines time division multiple access (TDMA) with trellis-coded QAM modulation.

The recommendation of the authors is that further investigation into in situ techniques for connecting subsea instrumentation to submarine cables should be undertaken. Several potential techniques which may have merit have been identified and would be far less costly than the normal cable ship operations. These techniques, however, are considerably more complicated than the non-invasive inductive technique and would require significant development.



## ***1.0 INTRODUCTION***

The feasibility of using non-invasive inductive telemetry techniques to couple oceanographic data onto existing submarine telephone cables has been investigated. A computer model of the transmission line was developed and tested against known analytical solutions. A series of in-water experiments using a coaxial cable to simulate the submarine cable with appropriately scaled frequencies and length was performed to verify the model's predictions. In parallel with this activity, an analysis of optimal bandwidth utilization, including system protocols, modulation techniques, and coding options was conducted to quantify the data rates and power levels achievable on existing submarine telephone cables.

Following the negative results obtained during the in-water tests, a design review was held to evaluate the procedures used during the experiments and to discuss the underlying physics behind the problem. Discussions concerning other possible techniques for non-invasive and invasive signal telemetry were also held. Participants at this review were senior engineering staff at WHOI. A summary of the design review is included as an Appendix. Opinions from members of the Northeastern University staff and Margus Telecommunications International staff were also solicited.

Results of the feasibility study can be summarized as follows:

1. The non-invasive inductive telemetry technique failed to generate a signal between the inner and outer conductors of an immersed (or non-immersed) cable due to mutual inductance between the two conductors. The inner and outer conductors, in essence, act as a single transmission line. Since no difference between the signals on the inner and outer conductors develops as the signals propagate along the cable, the repeaters have nothing to amplify.

2. The power requirement to transmit signals on an SF type cable are quite low and at the required frequencies could be inductively coupled very efficiently if the circumstances were right.

3. The optimal access method for an SF type cable system for ocean data telemetry uses TDMA (Time Division Multiple Access). System throughput of the order of 6 Mbits per second in each direction is possible using very low power transmitters. This approach requires simple system protocols and simple subsea instrumentation with relatively sophisticated processing at the shore end. It is applicable to non-invasive or invasive signalling techniques, and is optimized for low power applications.

The work performed in this study was funded by a grant from IRIS with matching funds provided by WHOI. Neil Brown was Principal Investigator for the cable modeling and in-water experiments and John Proakis performed the bandwidth utilization studies. Dan Frye provided project management.

## ***2.0 COMPUTER MODEL OF SUBMARINE CABLE SYSTEM***

Figure 1 shows the general arrangement of the proposed inductive telemetry system whose purpose is to enable two-way communication between oceanographic instruments on the bottom of the ocean and shore-based researchers using existing submarine telephone cables as a transmission line. The idea that was investigated was to use inductive coupling to transfer signals to and from the cable. The original premise was that the submarine cable differed from a normal cable in that the shield, outer polyethylene jacket and the highly conducting seawater formed a secondary coaxial cable as shown in Figure 2.  $R_i$ ,  $L_i$ ,  $C_i$  and  $G_i$  (Figure 2) were the lumped constants representing each element of the "inner" coaxial cable, and  $R_o$ ,  $L_o$ ,  $C_o$ ,  $G_o$  were the lumped constants for the "outer" coaxial cable. The premise was that

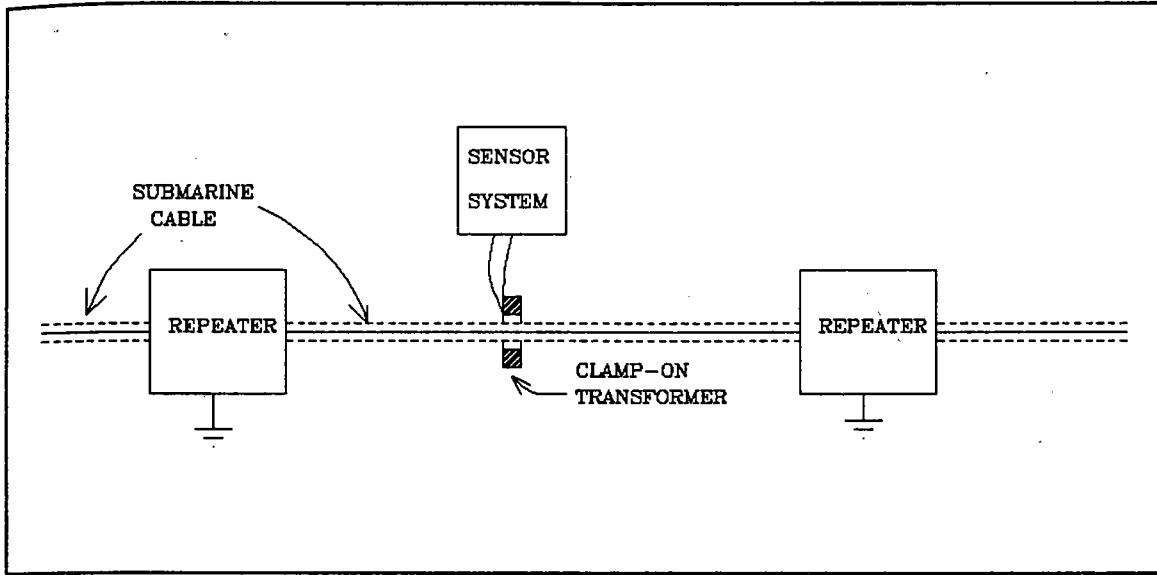


Figure 1 Proposed inductive telemetry system

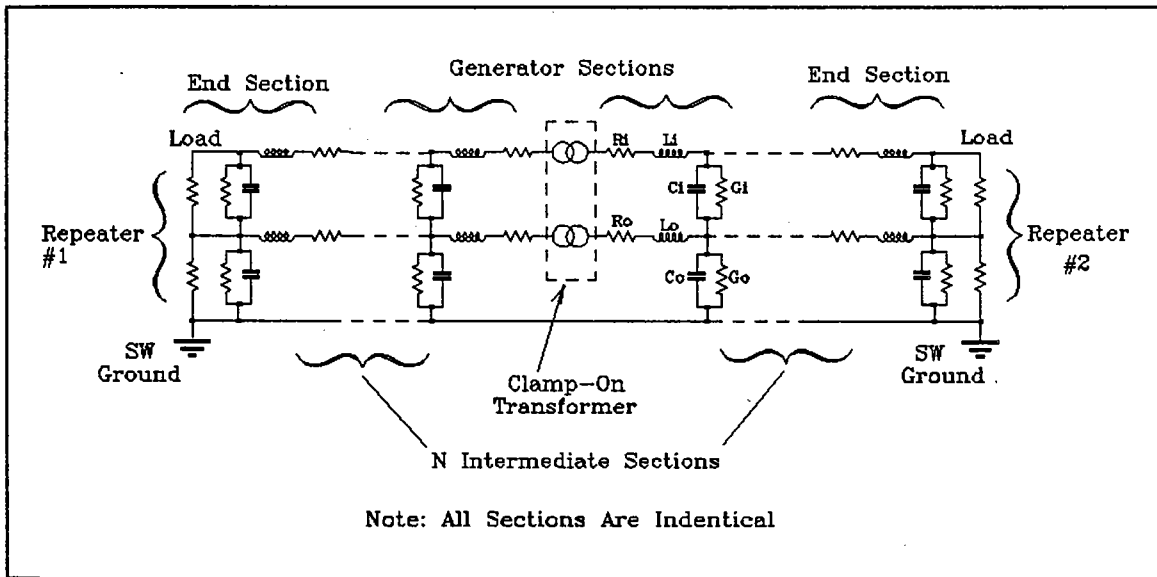


Figure 2 Electrical model of SF cable system

signals induced on the shield would be attenuated more rapidly than signals induced on the inner conductor due to the interaction between the outer conductor and the seawater. It was thought that the relatively low conductivity of seawater, compared to copper, would result in much more rapid loss of signal on the outer conductor, and that the two identical signals induced on the inner and outer conductors would differ significantly as they progressed along the cable, thus resulting in a net signal at the repeater.

## *2.1 Effect of Skin Depth*

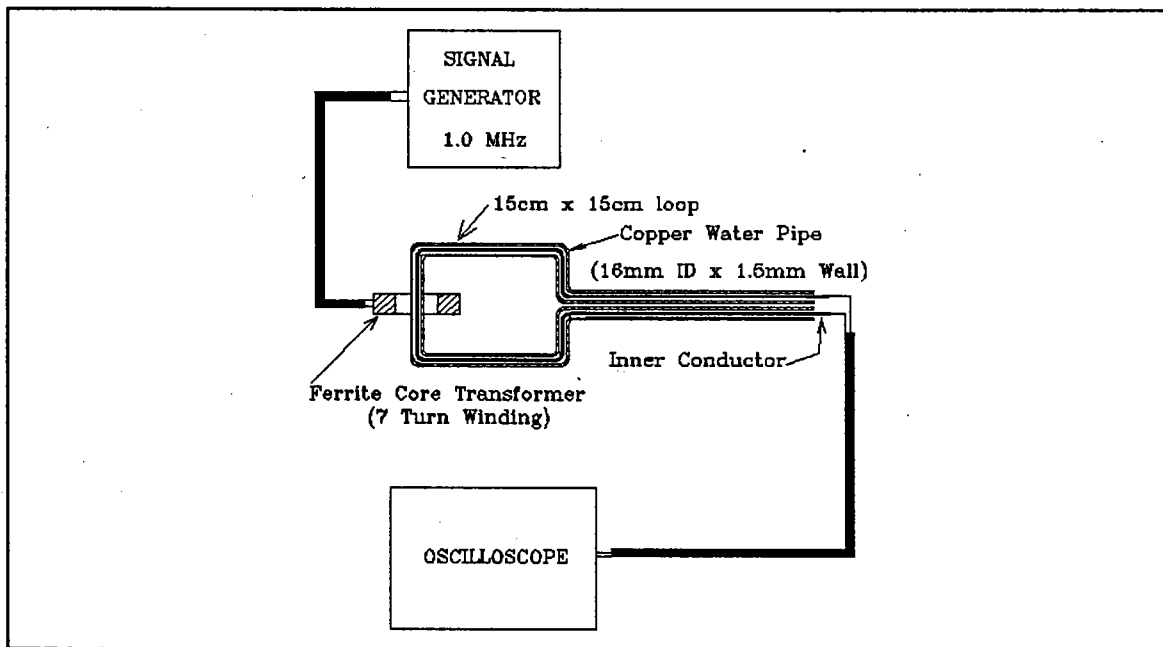
It was suggested by several reviewers of our original proposal that the outer conductor would effectively shield the inner conductor from the magnetic field produced by an encircling ferrite core (AC driver). We investigated this premise and proved that skin depth is not relevant in this situation.

At 1 MHz the skin depth in copper conductors is .0066 cm (.0026"), decreasing as the square root of frequency. However, skin depth is not relevant to this situation for the following reason. Since most of the magnetic field is contained within the ferrite core (permeability = 2700), the magnetic field encircles both the inner and outer conductors and induces a signal in them without impinging on them. According to Faraday's Law, the voltage induced in a circuit is given by

$$V = N * \frac{\delta\phi}{\delta t}$$

where V is the induced voltage and  $\phi$  is the total flux linking the circuit. It should be noted that a conductor does not have to be in a magnetic field to have a voltage induced in it. A voltage can be induced by passing a magnetic field through a space enclosed by the conductor.

A simple experiment was performed to show that skin depth is not a relevant factor. Figure 3 shows the details of the experimental setup. A square loop of copper pipe (15 cm x 15 cm) was assembled using standard water pipe and "elbows". The "legs" were 60 cm long to keep the output well away from the input winding of the transformer to eliminate the possibility of parasitic coupling. A 5-volt signal was applied to the 7-turn input winding of the toroidal transformer, and the voltage on the conductor inside the pipe was measured using an oscilloscope. The measured voltage was exactly one seventh of the input, clearly showing that skin depth was not a relevant factor even though the wall thickness was nine times the skin depth. The experiment was repeated with a 4-ohm resistor connecting the ends of the water pipe together with the same result, i.e., the anticipated signal was measured in both the inner and outer copper conductors.



**Figure 3** Experimental setup for testing skin depth hypothesis

## 2.2 Computer Simulation

A computer program was written to simulate the model shown in Figure 2. Two tests were performed on the model to verify its performance in known circumstances. In all cases 10,000 elements were used for the computations where each element represented a very small part of a wavelength. Figure 4 shows the SF cable characteristics used in the model. The two test cases are described below.

1. The thickness of the outer polyethylene jacket was reduced to almost zero thickness, thus simulating a normal coaxial cable. The model predicted exactly the same behavior for signals injected between the inner conductor and the outer conductor as the traditional transmission line equations for a short-circuited quarter wave section, an open-circuited quarter wave section, a short-circuited half wave section, an open-circuited half wave section and sections of various lengths terminated in the cable characteristic impedance (60 ohms).

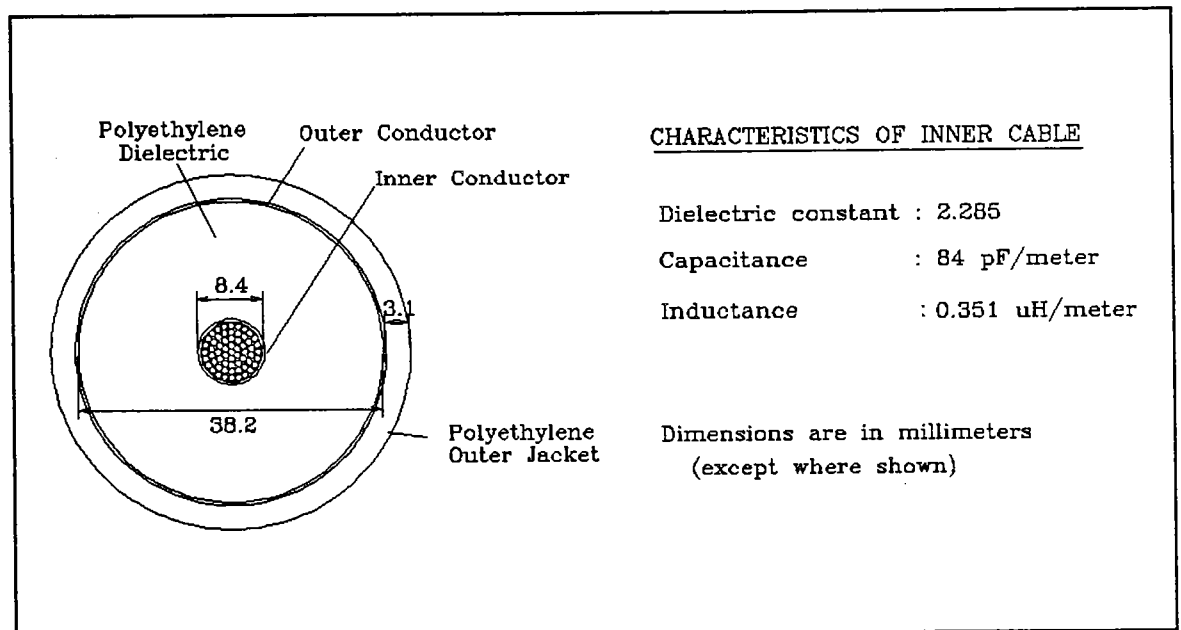


Figure 4 SF cable construction

2. The thickness of the outer polyethylene jacket was increased so that the overall diameter was three times the diameter of the shield, and the polyethylene dielectric was reduced to almost zero thickness so that the inner and outer conductors behaved essentially as one. When signals were injected between the outer conductor and the seawater and the same tests as described above were performed, the model predicted similar results except that the attenuation was considerably higher, as one would expect.

The results of these tests on the model showed that the computer program was accurately simulating the model, and it was felt that it would correctly predict the cable behavior when signals were simultaneously induced on both the inner and outer conductors by a "clamp-on transformer" at any point between the repeaters (Figure 2).

### ***3.0 EXPERIMENTAL VERIFICATION***

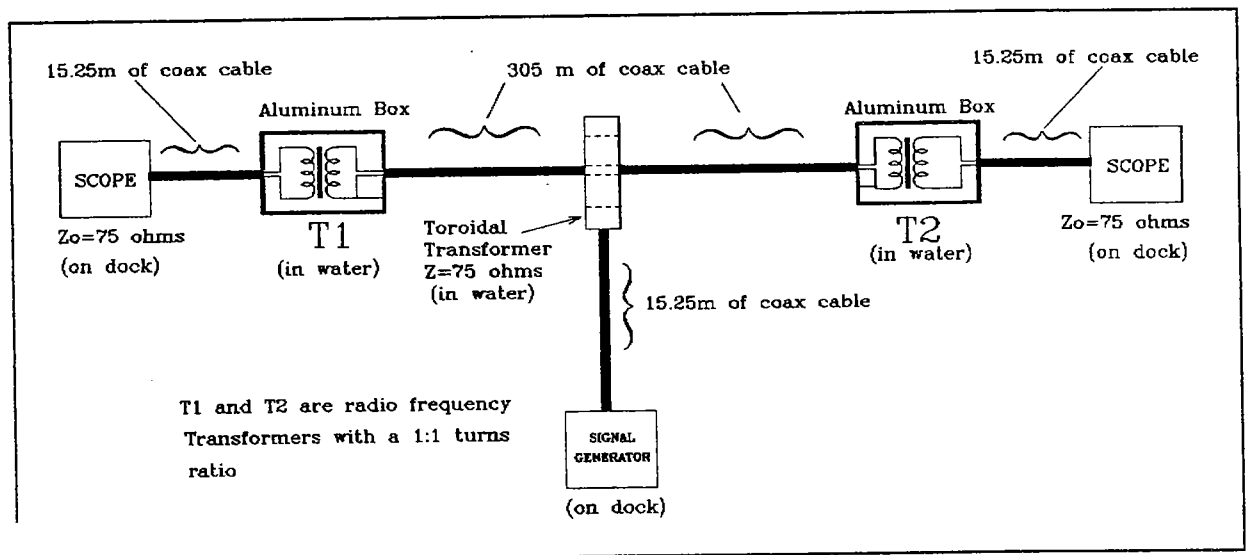
#### ***3.1 Experimental Results***

To test the validity of the computer simulation an experiment was performed at dockside at WHOI. Figure 5 shows the circuit details of the experimental setup. The 300 m lengths of coax cable were made up of 1 cm diameter 75 ohm "TV" cable. The tests were done at frequencies of 10 to 60 MHz. This combination of cable, cable length and frequency was designed to give the same attenuation as the submarine cable where the repeaters are 10 nautical miles apart and operate at frequencies of 0.5 to 6MHz. Table 1 shows the attenuation predicted by the computer simulation for the test cable as a function of frequency. The simulated "repeater" boxes were made of aluminum and were in direct contact with the water. The outer shields of the two 300 m lengths of cable were connected to the boxes to simulate the real situation. All exposed connections in the water were insulated with "SCOTCHFILL" insulating putty and self-vulcanizing tape. The transformers (T1 and T2) were used to allow the differential

voltage across the end of each 300 m length to be observed and to separate the "local" ground at the dock and seawater ground at the repeater boxes. Care was taken to insure that the impedance at all points was 75 ohms to avoid the possibility of standing waves.

FREQUENCY (MHz)	ATTENUATION (dB)
10	12.0
20	20.8
30	21.1
40	26.9
50	28.4
60	30.4

**Table 1** Results of simulation for the in-water experiment



**Figure 5** Experimental model of system



The experimental results showed that there was no detectable signal at any frequency at the repeaters even with 5 volts (rms) at the clamp-on transformer 7-turn primary winding (.71 volts on the cable). The experimental setup was checked and rebuilt with the same result. As a further check, a signal generator was connected to one of the repeaters and the signal measured at the other repeater with the following results.

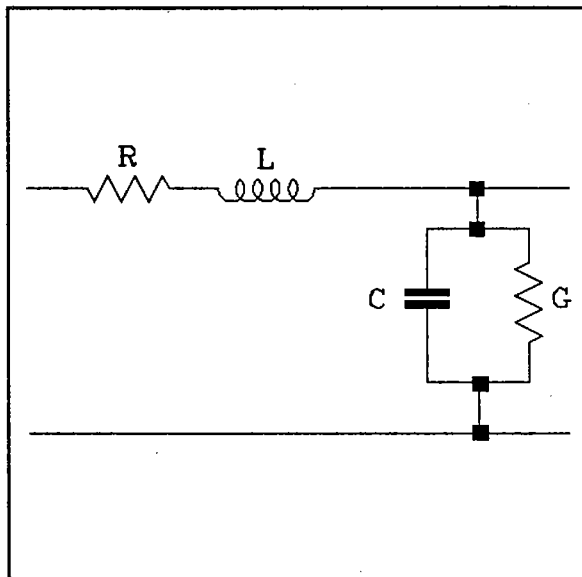
FREQUENCY (MHz)	ATTENUATION (dB)
10	17.3
20	26.0
30	30.5
40	33.9
50	34.2
60	38.8

**Table 2** Attenuation as a function of frequency for a signal injected directly into the test cable (600m)

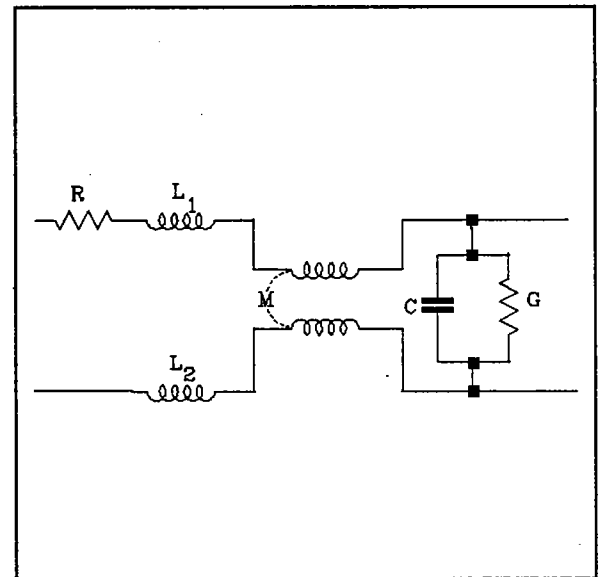
The above values agreed reasonably well with the calculated attenuation for the 600 m length of this cable. This showed that the cable, repeater boxes and all the connections were working correctly.

This left the question of why the predicted values in Table 1 and the experimental result showing no detectable signal were in complete disagreement. The conclusion was that the electrical model shown in Figure 2 was seriously in error, notwithstanding the tests done on the simulation program. After further investigation, it was recognized that the error in the model was that it did not take into account the mutual inductance between the inner conductor, outer conductor and the seawater ground. Even

though the simple model for a transmission line (twin lead or coaxial) shown in Figure 6a does not show the series and mutual inductances, it gives the correct result for a simple transmission line with a generator directly connected between the two conductors. The more complete representation (Figure 6b) including the mutual inductance effects is essential for the more complex case where we are inducing the same signal into both inductors, particularly when we include the third inductor formed by the seawater conductor.



**Figure 6a** Simple model of transmission line element



**Figure 6b** Model representation including mutual inductance effects

Frederick W. Grover [1] in his book (page 280 of Inductance Calculations published by ISA) states the following.

*For a coaxial cable in which the current flows in opposite directions in the two conductors, the inductance of the cable is equal to self inductance of the inner conductor plus the inductance of the outer conductor minus twice their mutual inductance. The mutual inductance of the two conductors is equal to self inductance  $L_2$  of the outer conductor. If,*

therefore,  $L_1$  denotes the inductance of the inner conductor, the inductance of the return circuit is

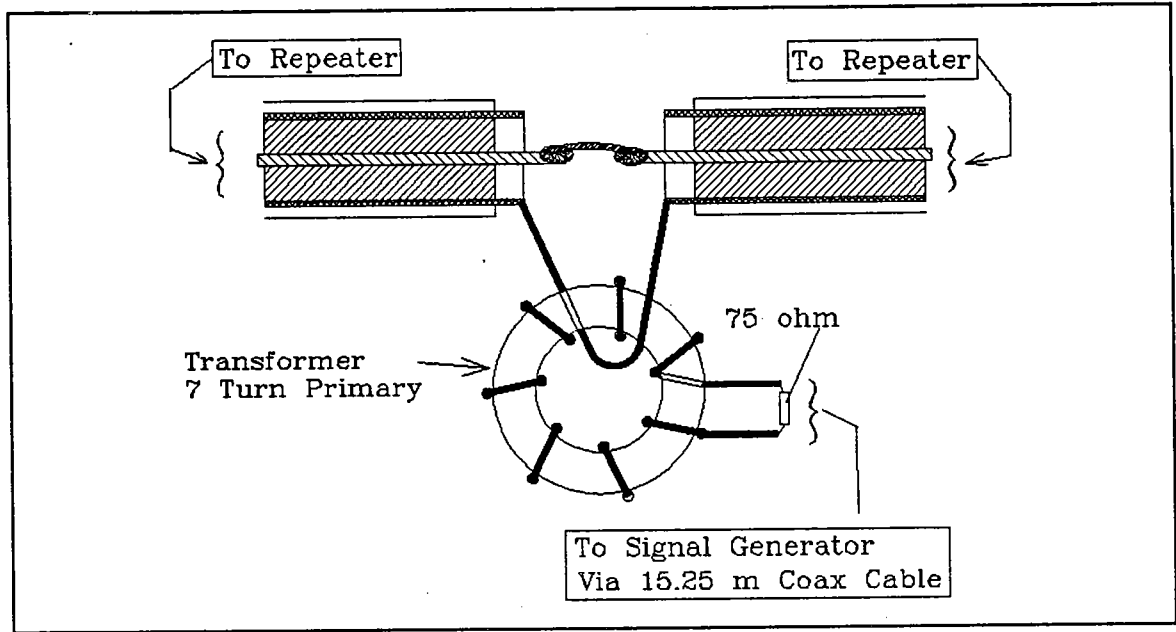
$$\begin{aligned} L &= L_1 + L_2 - 2L_2 \\ &= L_1 - L_2 \end{aligned}$$

Since the phase of the voltage induced in series with one conductor by the mutual inductance is at  $90^\circ$  to the current in the other conductor, the effect of the mutual inductance would be completely different when the currents in the inner and outer conductors were flowing in the same direction; this is the case when identical signals are induced in both conductors by a clamp-on transformer. These mutual inductance effects explain the discrepancy between the computer simulation and the in-water tests. Further, unless the voltages induced in the inner and outer conductors are different at the injection point (i.e., the clamp-on transformer), the response at the repeaters will inherently be zero.

### ***3.2 Additional Tests***

By the time we recognized the reason for the discrepancy between the computer model and the experimental results, we felt fairly certain that the results of the next three tests described below would be negative. However, they were very easy to perform and confirmed our conclusions that there is no non-invasive method of inducing high frequency signals into a submarine cable.

Additional tests were performed at dockside to better understand the initial results and to investigate other methods which could be used to couple signals into a submarine cable. The first test was to cut the 600 m cable at the center and to rewire it as shown in Figure 7. In this case the clamp-on transformer induced a signal into the outer conductor only when the inner conductors were directly connected. The transformer was the same one as used before. Figure 7 does not show the insulation used to protect the transformer and the exposed ends of the cable. Table 3 shows the result of measurements of signals received at the repeaters for the frequencies shown. The results were essentially



**Figure 7** Experimental configuration for inducing signal in the outer conductor only

FREQUENCY (MHz)	ATTENUATION
10	31.3
20	36.0
30	40.0
40	42.1
50	42.2
60	42.8

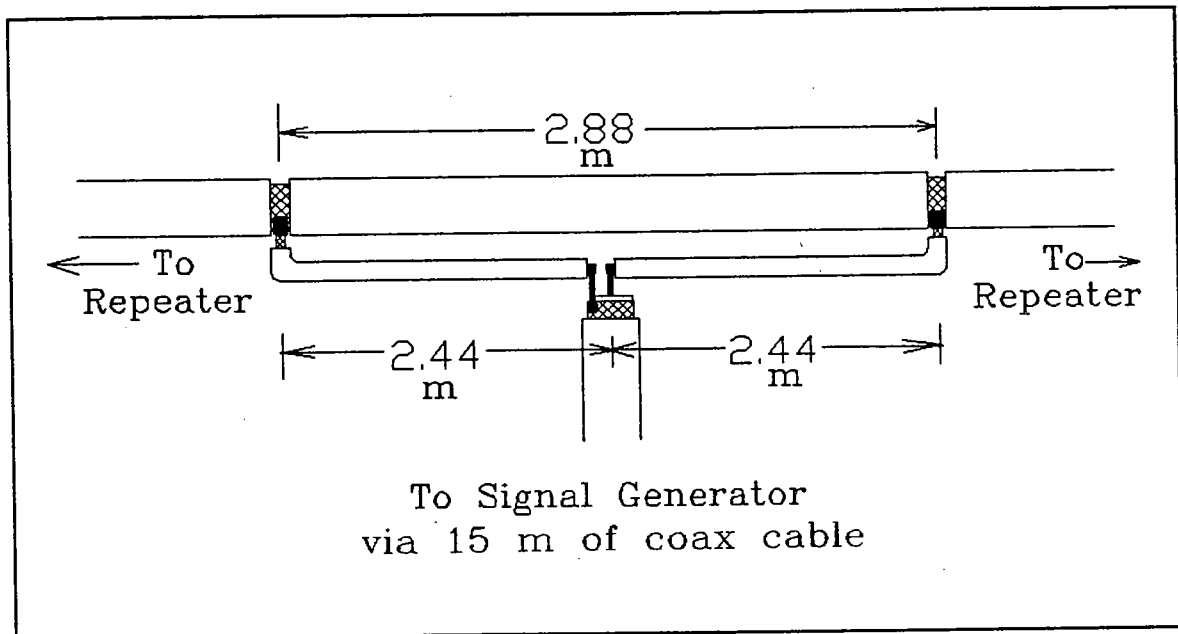
**Table 3** Attenuation of signals induced in the outer conductor after propagating 300m

the same for the signals received at both repeaters. The same test was repeated with the inner conductors coupled to the transformer and the outer conductors directly connected, thus inducing a signal into the inner conductor only. The results at both repeaters were the same as those shown in Table 3. The figures agree reasonably well ( $\pm 1.5$  db) with the calculated

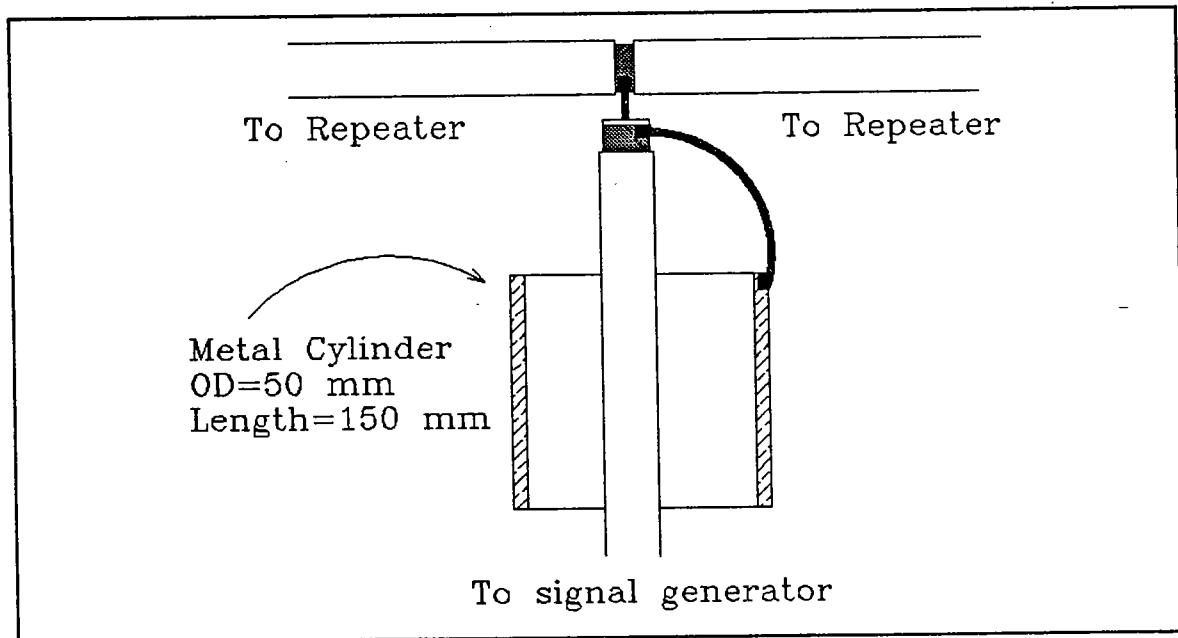
values and are consistent with the values in Table 2 if one allows for the 2-to-1 difference in length and for the fact that a signal injected into a conductor at the center travels in both directions, producing an amplitude in either direction that is one half of the injected signal.

Two other tests were performed at dockside. The first is shown in Figure 8. This method was intended to induce a signal into a half wave section of the outer conductor by driving it with two quarter wave sections connected as shown in Figure 8. This is the same method used to drive a half wave dipole antenna. Obviously the presence of the 300 m lengths of cable to each repeater would modify the voltage induced in the outer conductor. Insulation was stripped from the outer conductor in two places, 2.4 m apart, at the center of the 600 m length. The 2.4 m distance is equal to one half wavelength at 30 MHz. The exposed sections were connected to a 15 m length of coax via two quarter wave lengths of 26 gauge hook-up wire, all of which were insulated. The other end of the 15 m length was connected to a signal generator on the dock. When a 5 volt signal was applied to the cable, no signal was detected at the repeaters. The absence of any detectable signal was due to the fact that in a very short distance along the cable in either direction the same signal induced in the outer conductor is induced in the inner conductor by the mutual inductances shown in Figure 6b, resulting in a zero net difference between the two signals.

The second test is shown in Figure 9. Once again this was another attempt to generate a signal in the outer conductor by directly applying a signal between the outer conductor and seawater ground. The outer conductor was exposed at the center point and connected at one end to the center conductor of a 15 m length of coax, and the other end to the signal generator. The metal cylinder forms a connection to the seawater ground. When a 5 volt signal was applied to the cable, no signal was detected at the repeaters. Once again the effect of the mutual inductances mentioned above resulted in zero net signal at the repeaters.

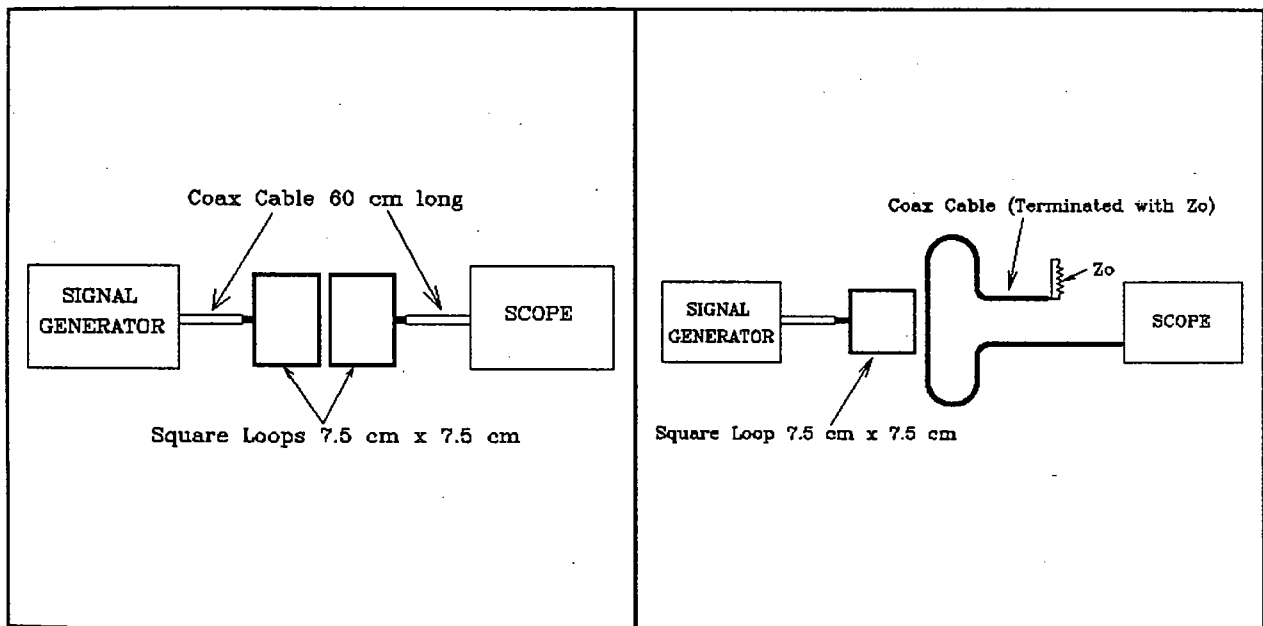


**Figure 8** Experimental setup for the "dipole antenna" configuration



**Figure 9** Experimental setup for directly driving the outer conductor

A final test was done in the lab to determine if magnetic induction from a nearby conductor could be used to generate a detectable signal at the repeaters. Figure 10 shows the details of this test. It involved two setups. The first (Figure 10a) established the relationship between the signal induced in a simple loop of insulated wire from a nearby loop connected to a generator. When the loops were essentially touching but not in electrical contact, the induced signal in the right-hand loop (see Figure 10a) was about 25% of the signal applied to the left-hand loop. In the second setup (Figure 10b) the right-hand loop was replaced by a loop made up of 75 ohm coaxial cable terminated at one end with a 75 ohm resistor and connected to a scope having an input impedance of 75 ohms. Even at closest approach there was no detectable signal.



**Figure 10a** Signal induced in a simple loop

**Figure 10b** Loop test with coaxial conductor

In this case the skin depth effect would prevent the magnetic field from the driven loop from penetrating the coax, i.e., it would remain entirely outside the outer conductor. The presence of the outer conductor would distort the magnetic field produced by the driven loop so that it passed around the loop (one side or the other). Thus identical voltages were induced in both the inner and outer conductors with no net signal at the detector.

### ***3.3 Conclusions***

The conclusions drawn from these results is that the only way to obtain any signal at the repeaters is to generate (or induce) a signal in either the inner or the outer conductor but not both. This fact effectively rules out the non-invasive inductive technique for gaining access to submarine cable bandwidths. Since the inductive method requires an encircling magnetic field, which by definition produces an identical signal in both inner and outer conductors, it cannot generate a differential input. Ironically, if skin depth did truly shield the inner conductor from the induced field, the technique would work as was originally predicted.

### ***4.0 BANDWIDTH UTILIZATION***

This section presents an analysis of the optimal methods for using submarine telephone cables for ocean data telemetry. In this analysis it has been assumed that the telephone cable will be used to transmit data from a variety of different sensors or sources. Some sources may generate data on a continuous basis, while others may generate and transmit data intermittently, perhaps, when polled via commands from shore. An important task is to design a bandwidth allocation method in conjunction with a bandwidth efficient modulation method that accommodates such diverse types of data sources. Below, we consider multiple access methods and modulation and coding methods based on a given



set of system design objectives. These results are applicable to the cable system analyzed regardless of the methods used to gain access to the cable.

#### *4.1 System Parameters for the SF Submarine Cable System*

The characteristics of the SF submarine cable system are described in the *Bell System Technical Journal*, May-June 1970. (The analysis presented here is for the SF system; a similar analysis for the SD system is feasible, but has been postponed due to funding restraints). In brief, the cable bandwidth is subdivided into two frequency bands, the low band, which covers the range of 564 kHz to 2788 kHz, and the high band, which covers the range of 3660 kHz to 5884 kHz. Hence, each band has a bandwidth of about 2.22 MHz. The low band is used for transmitting signals in one direction, and the high band is used to transmit signals in the other direction. Each band is comprised of about 720 3kHz telephone channels.

Repeaters are used at 10 nm intervals to boost the signal level. The output power from each repeater is 20 dBm. The cable has a loss of approximately 4dB/nm at a nominal frequency of 6 MHz. The noise figure  $F$  for each repeater is a little less than 8 dB, i.e.,  $F \leq 8$  dB. The cable also includes equalizers at spacing intervals of about 190 nm to correct for channel (linear) distortion.

To illustrate the value of the signal-to-noise ratio at the repeaters, let  $P_T$  denote the transmitted power level and let  $N_0 = kT_0$  be the power spectral density of the thermal noise corrupting the signal, where  $k$  is Boltzmann's constant ( $1.37 \times 10^{-23}$  joules/degree) and  $T_0$  is room temperature ( $290^\circ$  K). Hence,  $N_0 \approx 4 \times 10^{-21}$  watts/Hz and the noise power in a bandwidth  $B_N$  is  $P_N = N_0 B_N$ . For example, if  $B_N = 2.22$  MHz, then  $P_N = 8.88 \times 10^{-15}$  watts. If the

signal is transmitted at a power level of 20 dBm, then  $P_T = 0.1$  watts and

$$10 \log_{10} \left( \frac{P_T}{P_N} \right) = 10 \log \frac{10^{-1}}{8.88 \times 10^{-15}} = 130.5 \text{ dB}$$

For a cable transmission loss of 4 dB/nm, the loss of a single hop is 40 dB and the noise figure of the repeater after the first hop is 8 dB. Therefore, the received SNR at the first repeater is

$$\begin{aligned} \left( \frac{S}{N} \right)_1 &= \left( \frac{P_T}{P_N} \right)_{dB} - L_{dB} - F_{dB} \\ &= 130.5 - 40 - 8 = 82.5 \text{ dB} \end{aligned}$$

where  $L_{dB}$  is the single hop loss of the cable and  $F_{dB}$  is the noise figure of the repeater. If we have a cable length of 4,000 nm and, hence, 400 repeaters, the SNR at the receiver is (approximately) the SNR at the first repeater minus the additional noise power introduced by the 400 repeaters in the channel. Hence, the SNR at the receiver is (approximately)

$$\begin{aligned} \left( \frac{S}{N} \right)_R &= \left( \frac{S}{N} \right)_1 - 10 \log 400 \\ &= 82.5 - 26 = 56.5 \text{ dB} \end{aligned}$$

This is the received SNR for a signal that is transmitted at a power level of 20 dBm and occupies a bandwidth of 2.22 MHz. It is sufficiently high to support high level modulation methods.

## ***4.2 Objectives of the System Design***

As a design specification, we postulate having between 8 and 16 data sources (modems) coupled to the cable in each direction. We also anticipate a maximum bit rate (uncoded) of 400 kbps generated by sensors located in the vicinity of each modem. For example, we may have 6 high data rate sources, each generating data at a rate of 60 kbps. In addition, we may have about 20 low data rate sources, each generating data at a rate of 1200 bps. Hence, these sources will generate a total bit rate of 384 kbps. Therefore, a nominal bit rate of 400 kbps is a reasonable benchmark. With 8 modems, the total bit rate is 3.2 Mbps, while with 16 modems, the total bit rate becomes 6.4 Mbps. Consequently, the bit rate-to-bandwidth ratio will range from 1.5 bits/Hz to 3 bits/Hz for an uncoded system. These bit rates can be achieved with the use of phase coherent modulation techniques, such as phase-shift keying (PSK), amplitude-shift keying (ASK), or quadrature amplitude-shift keying (QASK or QAM).

An extremely important factor in the design of the modem is the amount of power required to transmit the signal. Since the modem is presumed to be battery powered, we have assumed that the power of the signal transmitted by the modem is to be minimized. A power level of one watt per modem appears to be a practical limit assuming about 5% efficiency in the transfer of power to the transmission line. This power constraint influences our choice of a multiple access scheme as well as the choice of modulation and coding techniques.

## ***4.3 Multiple-Access Methods***

We considered three methods for allocating the available bandwidth to the various users. One is frequency division multiple access (FDMA) in which a part (or all) of the available cable bandwidth is subdivided into distinct frequency channels and each data source is assigned a frequency band. FDMA is particularly suitable as an access method if the data sources

generate and transmit data continuously. However, FDMA is not a suitable access method when there are many data sources that are low duty cycle, i.e., they transmit intermittently. Another major limitation in FDMA is the loss in transmitter power inherent in transmitting multiple signals that have a large peak-to-average power.

Time-division multiple access (TDMA) is one alternative to FDMA. In TDMA each data source is assigned a time slot for transmitting the data; data are usually transmitted in packets. A TDMA protocol must be designed for assigning time slots to the various sources. A command channel that is monitored by all sources may be employed for time-slot assignment.

Code division multiple access (CDMA) is another potential multiple access method. In CDMA each data source is assigned its own signature signal, usually called a pseudo-noise (PN) code sequence. All data sources share a common wide bandwidth, and their transmissions are distinguished from one another at the receiver by means of cross-correlation by the respective PN code sequences. Hence, the various sources may transmit data via CDMA over the common allocated bandwidth either when polled or when an event triggers the collection and transmission of data. CDMA more easily accommodates the introduction of additional data sources into the system and requires a relatively simple protocol for channel access.

A major problem with CDMA is the need to maintain power control of all the users sharing the common bandwidth. Since the signals of other users appear as additive noise in the demodulation of a desired signal, the noise level increases significantly when one or more users transmit at a higher power level than the desired signal. Consequently it is important to maintain relatively tight control of power levels for the users of the common channel bandwidth. Usually power control involves monitoring the transmitter power levels of each user at the receiver and signaling back to the user if its power level is to

be increased or decreased. Such information can flow along a common command channel that is monitored by all users.

Of the three access methods that we considered, FDMA appears to have a distinct disadvantage. This is due to the need to back off or reduce the gain in the transmitter power amplifier in order to accommodate the large peak-to-average values of the composite signal from all users. Therefore, the choice of access method reduces to either TDMA or CDMA.

If we wish to accommodate many high data rate users transmitting at 60 kbps via CDMA, we should allocate the entire 2.22 MHz bandwidth as the common bandwidth for all users transmitting in one direction. This bandwidth allocation is necessary to provide sufficient processing gain (ratio of channel bandwidth to information signal bandwidth) to the high data rate users. It makes no sense to subdivide the 2.22 MHz bandwidth among the 8 to 16 modems connected to the cable. This means that all modems that transmit in the same direction will share the common wide bandwidth. The problem of power control at the modems now becomes serious because some modems are closer to the receiver than other modems. This is usually called the **near-far problem** in a CDMA system. Therefore, the receiver must now exercise power control not only among users sharing a single modem, but also among all users that transmit data in the same direction. The near-far problem will definitely require precise power control of the transmissions from all users in a CDMA system. Although the problem of power control presents a serious difficulty in the design of a CDMA system, we feel that an adequate power control algorithm can be designed and implemented.

As the alternative, the implementation of a TDMA system appears to pose fewer problems. Specifically, the modems attached to the cable can be designed to transmit in non-overlapping frequency bands. For example, if we wish to design a system that employs 10 modems for transmitting data in each direction, the 2.22 MHz can be subdivided into 10 non-overlapping frequency bands, each of which is about 220 kHz wide. Then, a

common modulation and coding method can be designed for all the modems, each of which will provide a throughput of about 400 kbps (uncoded), and a somewhat higher throughput for coded data. Thus, all users being served by a single modem will be assigned time-slots for their transmissions. A common command channel that is monitored by all data sources would be used for time-slot assignment.

In considering the choice between TDMA and CDMA, we have decided in favor of a TDMA system. Its implementation poses fewer problems than CDMA, which has the distinct problem with power control over all the users.

#### 4.4 Modulation and Coding

In this section we consider the design of modulation and coding that will be used in conjunction with TDMA to achieve the overall design objectives specified in Section 4.2.

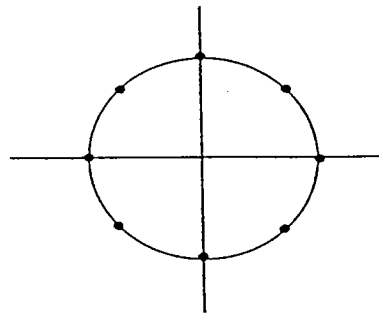
First, we determine the bandwidth requirements and then we will specify the type of modulation. We assume that the lowpass equivalent transmitted signal has the form (1)

$$v(t) = \sum_{n=-\infty}^{\infty} a_n g_T(t-nT)$$

where  $g_T(t)$  is a basic pulse that is bandlimited to  $W$  Hz,  $1/T$  is the symbol rate, and  $\{a_n\}$  is a sequence of complex-valued signal points selected from a two-dimensional (PSK or QAM) signal constellation. Figure 11 illustrates  $M = 8$  PSK and  $M = 8$  QAM signal constellations. The number of bits per transmitted symbol is defined as  $k = \log_2 M$ .

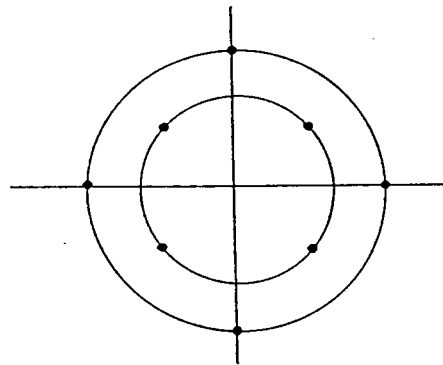
The average power spectral density of the lowpass equivalent transmitted signal is (2)

$$S_v(f) = \frac{\sigma_a^2}{T} |G_T(f)|^2$$



(a)

M=8 PSK



M=8

(b)

M=8 QAM

Figure 11 M=8 PSK and QAM signal constellations

where  $G_T(f)$  is the Fourier transform of  $g_T(t)$  and  $\sigma_a^2$  is the variance of the information symbols  $\{a_m, m = 1, 2, \dots, M\}$ . We select  $g_T(t)$  to be a pulse having a raised cosine spectrum with a roll-off parameter  $\alpha$ , as shown in Figure 12. Then, the channel bandwidth required to transmit such a signal is  $(1 + \alpha)/T$ . But  $T = k/R_b$ , where  $R_b$  is the desired bit rate of the modem. (Recall that the nominal bit rate of 400 kbps was specified in Section

4.2.) Then, the channel bandwidth required to transmit the (uncoded) signal is

$$B_c = \frac{1+\alpha}{T} = \frac{R_b(1+\alpha)}{k} \quad \text{(uncoded) (3)}$$

If additional redundancy is introduced via error correcting coding, the required channel bandwidth is increased by the factor  $1/R_c$ , where  $R_c$  is the code rate. Hence,

$$B_c = \frac{R_b(1+\alpha)}{kR_c} \quad \text{(coded) (4)}$$

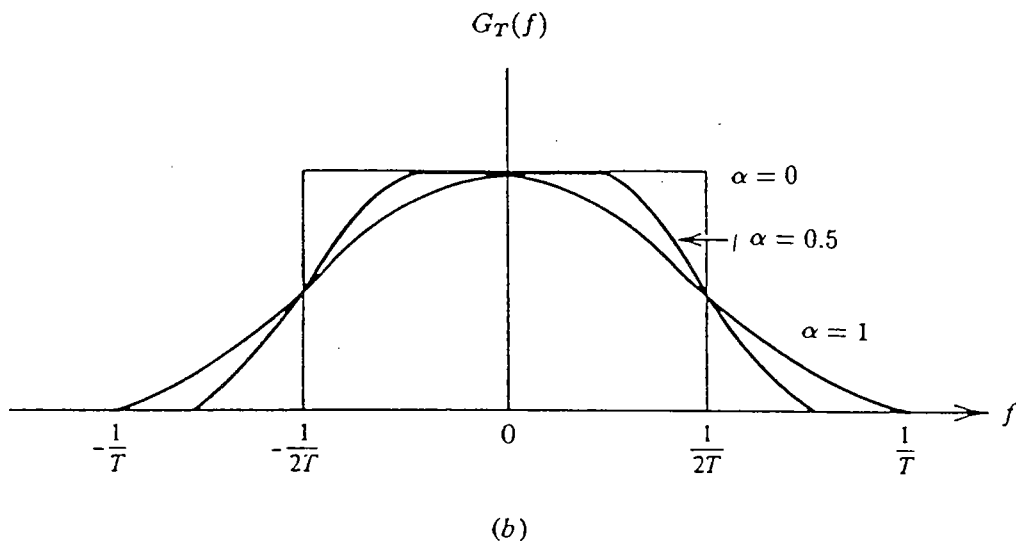


Figure 12 Raised-cosine spectra



The available bandwidth for each modem in a TDMA system is simply the total channel bandwidth for transmitting in one direction divided by the number of modems, i.e.,

$$B_a = \frac{2.22 \times 10^6}{N_m} \quad (5)$$

where  $N_m$  is the number of modems. Clearly, we must have  $B_c \leq B_a$ . Therefore,

$$\frac{R_b(1+\alpha)}{kR_c} \leq \frac{2.22 \times 10^6}{N_m} \quad (6)$$

or, equivalently,

$$k = \log_2 M \geq \frac{R_b N_m (1+\alpha)}{2.22 \times 10^6 R_c} \quad (7)$$

**Example:**

Determine the size  $M$  of the signal constellation when

$$R_b = 400 \text{ kbps}, N_m = 10, \alpha = 0.30, R_c = 1/2.$$

**Solution:**

From these parameters, we use (7) to obtain the value of  $k$ . Thus, we obtain  $k \geq 4.7$ . Since  $k = \log_2 M$  must be an integer, we select  $k = 5$  and, hence,  $M = 32$ .

The choice of the type of modulation is an important issue. If  $k = 2$ , the best choice for a two-dimensional constellation is  $M = 4$  PSK. If  $k \geq 3$ , we select a signal constellation from the class of QAM signal constellations, which require less average transmitter power compared with PSK signal constellations. For example, the  $M = 8$  QAM signal constellation shown in Figure 11 provides a 1.43 dB power advantage compared with  $M = 8$  PSK. The  $M = 16, 32, \text{ and } 64$  rectangular signal constellations shown in Figure 13 yield gains of 4.14 dB, 7.01 dB and 9.95 dB,

respectively, relative to PSK signal constellations of the same size (see Proakis [2], Chapter 4).

A gain of 3 dB to 4 dB in power savings can be easily achieved by the use of trellis-coded modulation at the modem and Viterbi detection at the receiving terminal. This is a significant performance gain which allows us to reduce the power consumption and thus to increase battery life at the modem. Consequently, we propose to use trellis-coded QAM modulation in all modems. An Ungerboeck-type trellis code of rate  $k/(k + 1)$  is recommended (see Proakis [2], Chapter 5 and Ungerboeck [3], [4]).

The modulator and demodulator are illustrated in block diagram form in Figures 14 and 15, respectively. We note that the modulated signal is digitally synthesized at the modem and digitally demodulated at the receiver.

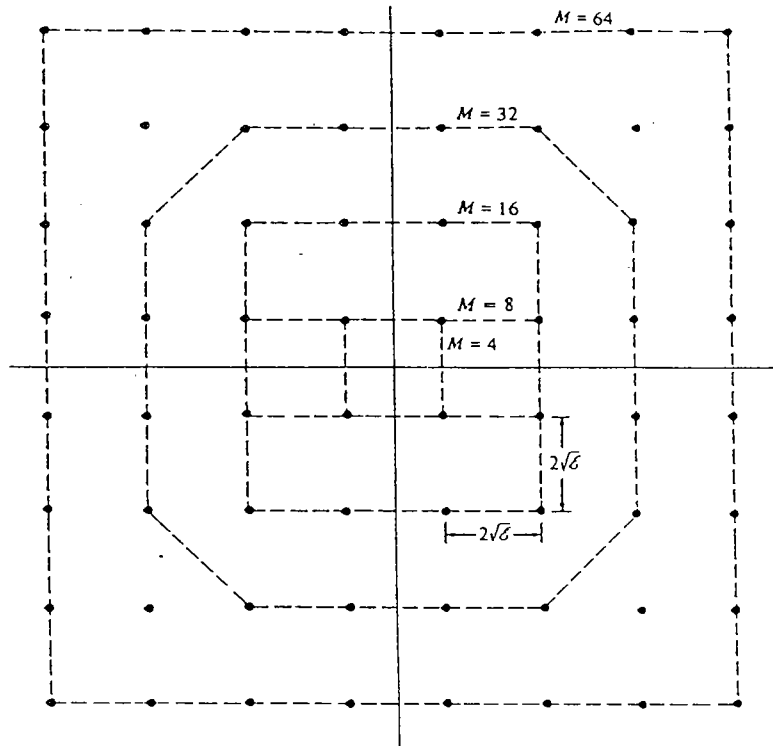


Figure 13 Rectangular QAM signal constellations

The signal-to-noise ratio (SNR) required to achieve a given level of performance can now be determined. As a reference point, we may use binary ( $k = 1$ ) PSK at an error probability of  $10^{-6}$ , which requires a received SNR

$$\left( \frac{\epsilon_b}{N_0} \right)_{dB} = 10.8 \text{ dB/bit} \quad (8)$$

Then,

$$\frac{\epsilon_b}{N_0} = \frac{P_R T_b}{N_0} = \frac{P_{av}}{R_b N_0} = 12 \quad (9)$$

or, equivalently,

$$P_R = 12 R_b N_0 \quad (10)$$

where  $N_0 = 4 \times 10^{-21}$  watts / Hz. Therefore, with  $R_b = 400$  kbps, we find that  $P_R = 1.92 \times 10^{-14}$ . Hence,

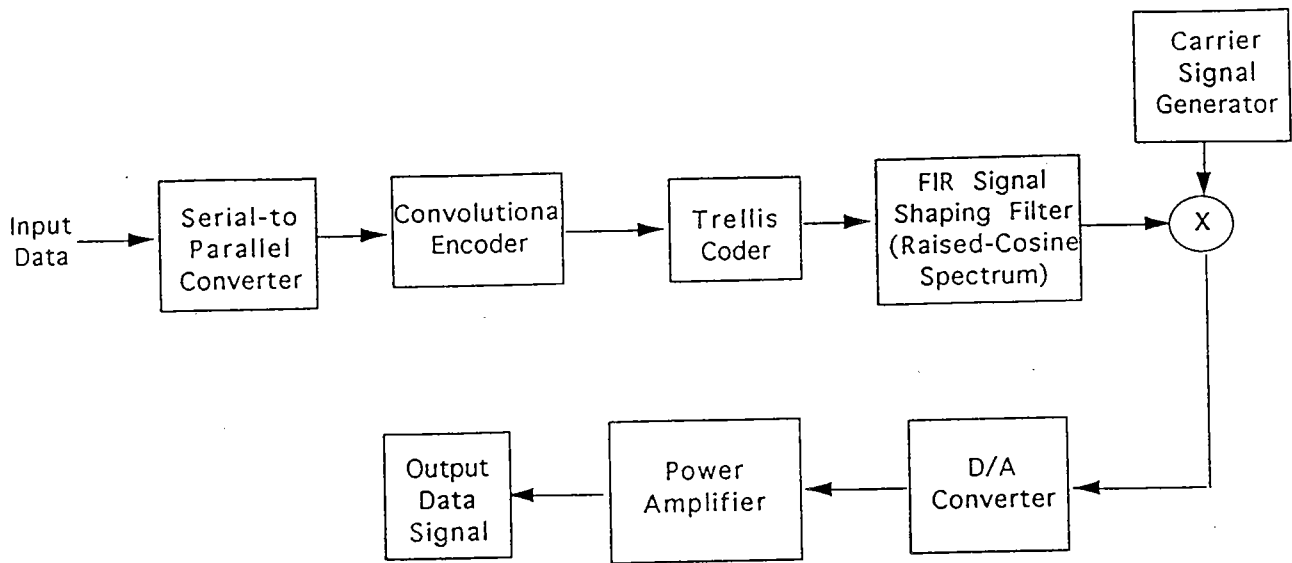
$$10 \log_{10} P_R = -107.2 \text{ dBm}. \quad (11)$$

If we employ a QAM signal constellation with  $M = 2^k$  signal points, every additional bit per symbol (increase of  $k$  by one) requires an additional power of 3 dB. On the other hand, the use of trellis code reduces the power requirements by  $G_c$  dB. Finally, if we employ error-correcting coding, we may achieve a further reduction in transmitter power by the coding gain  $C_g$  dB.

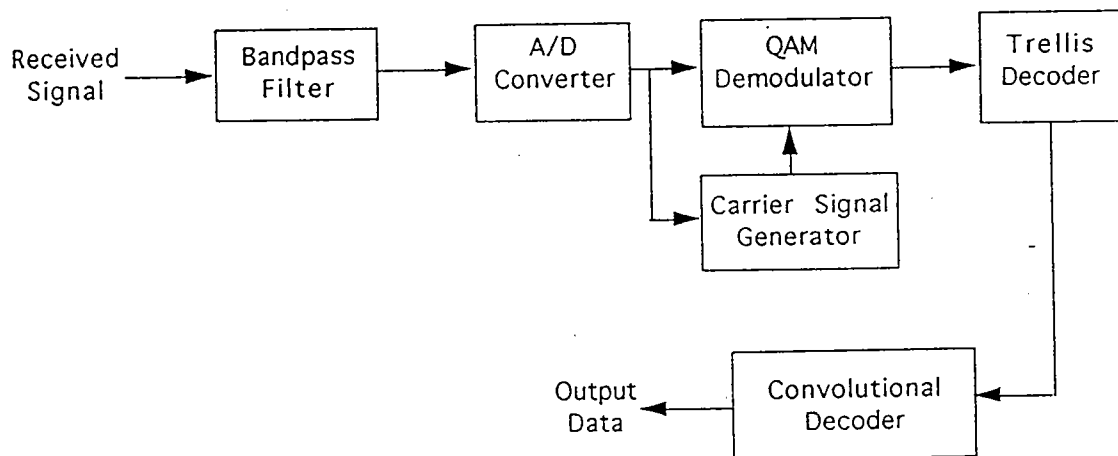
Therefore, the average transmitted power is

$$10 \log P_R = 10 \log(12 R_b N_0) + 3k - G_c - C_g \quad (12)$$

Typical coding gains that can be achieved by rate  $R_c = 1/2$  convolutional codes range from 4 dB to 8 dB. For example, a rate  $1/2$ , constraint length  $K=7$  convolutional code with hard-decision



**Figure 14** Block diagram of modulator for generating trellis-coded modulation signals



**Figure 15** Block diagram of demodulator for trellis-coded modulation signals

Viterbi decoding yields a gain of 4 dB relative to uncoded modulation (see Proakis [2], Chapter 5).

As indicated in Section 2, the transmitted power level is greater than the received power level by an amount equal to the sum of the single hop transmission loss  $L_{dB}$  and the cumulative noise figure from the chain of repeaters. Therefore,

$$\begin{aligned} 10\log P_T &= 10\log P_R + L_{dB} + N_p F \\ &= 10\log P_R + L_{dB} + F_{dB} + 10\log N_p \end{aligned} \quad (13)$$

where  $N_p$  is the number of repeaters. If we combine (12) with (13), we obtain

$$10\log P_T = 10\log(12R_b N_0) + 3k - G_c - C_g + L_{dB} + F_{dB} + 10\log N_p \quad (14)$$

**Example:**

Determine the transmitted power when  $R_b = 400$  kbps,  $N_0 = 4 \times 10^{-21}$ ,  $k = 5$ ,  $G_c = 4$  dB,  $C_g = 4$  dB,  $L_{dB} = 40$  dB,  $F_{dB} = 8$  dB,  $N_p = 400$

**Solution:**

If we substitute the values of the parameters into (14), we find that the transmitted power is

$$\begin{aligned} 10\log P_T &= -107.2 + 15 - 4 - 4 + 40 + 8 + 26 \\ &= -26.2 \text{ dBm} \end{aligned}$$

Hence, the average transmitted power is extremely small.

In conclusion, (14) may be used to determine the average transmitted power at the modem. The value of  $k$  and, hence, the signal constellation size  $M$  is determined from (7).

## 5.0 CONCLUSIONS AND RECOMMENDATIONS

The conclusions of the feasibility study are:

1. Non-invasive inductive coupling is not feasible on a submarine cable of coaxial construction where the repeaters amplify the signal difference between the inner and outer conductors.

2. In order to successfully propagate signals in the cable, a differential signal between the inner and outer conductors must be generated. This could be done by connecting the signal source in series with the outer conductor. To do this in situ would mean designing a device to cut around and through the outer jacket and the outer conductor. The two ends of the outer conductor would then be connected in series to a signal source. The cutting operation would have to be done carefully so that the insulation around the inner conductor could withstand the high DC voltage (typically as much as 4,000 V) on the inner conductor. This cutting/connection device would have to be designed so that it first clamped onto the cable and formed a leak proof seal. Ideally, it would support the cable to compensate for any weakening due to the cutting operation. Inductive techniques could be used efficiently in this process once the inner and outer conductors were separated so that a magnetic field could be devised that would encircle only one of the conductors. Whether this provides any advantage over a hard-wired connection depends on the design of the cutting operation.

3. Low power transmitters could be used to generate signals of sufficient SNR to be transmitted successfully across the ocean. Data throughput rates of  $6 \times 10^6$  bps in each direction are feasible, using of the order of one watt per signal source.

4. A large number of data sources could be accommodated on a typical SF type cable using TDMA techniques in conjunction with trellis-coded QAM modulation. These techniques make optimal use of the available bandwidth, power, and other system constraints. Minimum system complexity and power is required at each data source, with the sophisticated processing done on shore. This model would accommodate both a number of continuous high data rate instruments such as ocean bottom seismometers, as well as many low data rate devices. Provision is made for two-way communication where low bit rates are available from shore to each remote modem on a single command channel shared by all modems.

Based on these conclusions, the following recommendations are made.

1. Techniques for in situ connection between ocean instrumentation and submarine cables should be investigated. Those techniques that minimize the possibility of cable damage and that can be performed without lifting the cable to the surface should be given first priority. Installation techniques using ROVs should be investigated.

2. If the in situ connection problem can be solved economically, continued investigation of methods to acoustically and inductively interface sensors to transmitters should be performed.

3. If the re-use of submarine cables proceeds, a system architecture based on the conclusions of this report should be developed to take full advantage of the cable bandwidth.

## 6.0 REFERENCES

- [1] F. Grover, Inductant Calculations, ISA, p. 280.
- [2] J. G. Proakis, Digital Communications, Second Edition, McGraw-Hill, New York, 1989.
- [3] G. Ungerboeck, "Channel coding with multilevel/phase signals," IEEE Trans. Information Theory, vol. IT-28, pp 55-67, January 1982.
- [4] G. Ungerboeck, "Trellis-coded modulation with redundant signal sets, parts I and II," IEEE Communication Magazine, Vol. 25, pp 5-21, February 1987.



## 7.0 APPENDIX

Date: November 3, 1992  
To: Submarine Cable Project File  
From: Dan Frye  
Subject: Design Review Summary

A design review for the submarine cable project was held on 9 October 1992. Participants included Neil Brown, Dan Frye, Tom Austin, Ned Forrester, Sandy Williams, Steve Merriam, Al Bradley, Dick Koehler, and David Herold. The meeting was held from 10 a.m. to approximately 12:30.

To start the meeting I briefly outlined the purpose of the project and the purpose of the design review. Neil then described the analytical model he developed, the results it predicted and where he thought it was deficient. Neil then described the various experiments performed to first confirm the model (negative results) and then try and determine what the right physics are.

Questions were raised on a number of issues concerning the experimental set up, whether the tests were performed with and without inductive coupling (yes), how the measurements were made, etc.

A general discussion then ensued. The "skin effect" was discussed without complete agreement. While it was generally agreed that the skin effect did not shield the inner conductor, various arguments seemed to assume that skin effect was important. The results of these discussions were that Neil's experiments did conclusively show that inductive coupling would not work with a submerged coaxial cable. I tried to get a consensus on whether it made any difference if the cable were not submerged, but could not get a clear "no". I also tried to get a consensus on the statement that it is possible to induce a signal on the inner conductor - just not a differential signal between the inner and outer conductor, but no one felt that this question was posed with sufficient detail to answer.

We next discussed what we knew about the results of similar experiments at the University of Hawaii and concluded that these experiments ultimately corroborated ours.

Several suggestions were made to discuss the basic issue with MIT professors who had a profound understanding of the physics. Ned Forrester agreed to make some inquiries.

The discussion then turned to how it would be possible to use submarine cables for ocean data telemetry. Capacitive coupling was discussed and rejected. Microphonic coupling was suggested and rejected. Finally various techniques to cut through the outer insulating layer were discussed. Neil presented his idea to cut the outer jacket in two places and insert a signal generator in series between the two cuts. This approach was considered as reasonable as any since it did not require breaching the inner conductor and its 4000 V level nor did it require complete water sealing, since the outer shield is assumed to have some contact with the seawater. Various problems such as shield corrosion and loss of electrical contact between the two cuts were discussed with the conclusion that any loss of continuity in the outer shield could have disastrous consequences in the cable's ability to transfer data.

The overall conclusions of the design review were:

1. Neil's conclusion about why the model failed to predict the behavior of the in-water test is correct.

2. There is no way to use inductive coupling to gain access to the existing submarine cable bandwidth without an electrical connection to the inner or outer conductor.

3. In situ operations to develop and seal a direct electrical connection to the outer conductor are possible, but will require extensive development and testing of the tools and procedures needed for reliable operation.

4. There may be individuals at MIT (or elsewhere) who could provide more insight into the problem.

DEF/wwl

## DOCUMENT LIBRARY

March 11, 1991

### *Distribution List for Technical Report Exchange*

Attn: Stella Sanchez-Wade  
Documents Section  
Scripps Institution of Oceanography  
Library, Mail Code C-075C  
La Jolla, CA 92093

Hancock Library of Biology &  
Oceanography  
Alan Hancock Laboratory  
University of Southern California  
University Park  
Los Angeles, CA 90089-0371

Gifts & Exchanges  
Library  
Bedford Institute of Oceanography  
P.O. Box 1006  
Dartmouth, NS, B2Y 4A2, CANADA

Office of the International  
Ice Patrol  
c/o Coast Guard R & D Center  
Avery Point  
Groton, CT 06340

NOAA/EDIS Miami Library Center  
4301 Rickenbacker Causeway  
Miami, FL 33149

Library  
Skidaway Institute of Oceanography  
P.O. Box 13687  
Savannah, GA 31416

Institute of Geophysics  
University of Hawaii  
Library Room 252  
2525 Correa Road  
Honolulu, HI 96822

Marine Resources Information Center  
Building E38-320  
MIT  
Cambridge, MA 02139

Library  
Lamont-Doherty Geological  
Observatory  
Columbia University  
Palisades, NY 10964

Library  
Serials Department  
Oregon State University  
Corvallis, OR 97331

Pell Marine Science Library  
University of Rhode Island  
Narragansett Bay Campus  
Narragansett, RI 02882

Working Collection  
Texas A&M University  
Dept. of Oceanography  
College Station, TX 77843

Library  
Virginia Institute of Marine Science  
Gloucester Point, VA 23062

Fisheries-Oceanography Library  
151 Oceanography Teaching Bldg.  
University of Washington  
Seattle, WA 98195

Library  
R.S.M.A.S.  
University of Miami  
4600 Rickenbacker Causeway  
Miami, FL 33149

Maury Oceanographic Library  
Naval Oceanographic Office  
Stennis Space Center  
NSTL, MS 39522-5001

Marine Sciences Collection  
Mayaguez Campus Library  
University of Puerto Rico  
Mayaguez, Puerto Rico 00708

Library  
Institute of Oceanographic Sciences  
Deacon Laboratory  
Wormley, Godalming  
Surrey GU8 5UB  
UNITED KINGDOM

The Librarian  
CSIRO Marine Laboratories  
G.P.O. Box 1538  
Hobart, Tasmania  
AUSTRALIA 7001

Library  
Proudman Oceanographic Laboratory  
Bidston Observatory  
Birkenhead  
Merseyside L43 7 RA  
UNITED KINGDOM

<b>REPORT DOCUMENTATION PAGE</b>	<b>1. REPORT NO.</b> WHOI-93-03	<b>2.</b>	<b>3. Recipient's Accession No.</b>
<b>4. Title and Subtitle</b> Feasibility Study of Non-Invasive Telemetry Techniques for Use With Submarine Telephone Cables		<b>5. Report Date</b> January, 1993	
<b>7. Author(s)</b> Neil L. Brown, Daniel E. Frye and John Proakis		<b>8. Performing Organization Rept. No.</b> WHOI 93-03	
<b>9. Performing Organization Name and Address</b>  The Woods Hole Oceanographic Institution Woods Hole, Massachusetts 02543		<b>10. Project/Task/Work Unit No.</b>	
		<b>11. Contract(C) or Grant(G) No.</b> (C) (G)	
<b>12. Sponsoring Organization Name and Address</b>  Funding was provided by the IRIS Consortium under sub-award agreement No. 0169 and by the W.M. Keck Foundation through their Technology Innovation Awards.		<b>13. Type of Report &amp; Period Covered</b>  Technical Report	
		<b>14.</b>	
<b>15. Supplementary Notes</b>  This report should be cited as: Woods Hole Oceanog. Inst. Tech. Rept., WHOI-93-03.			
<b>16. Abstract (Limit: 200 words)</b>  The feasibility of using inductive coupling with existing submarine telephone cables for telemetry of data from ocean sensors was investigated. The submarine telephone cable was simulated with a computer model and the model results were tested experimentally by deploying 600 meters of coax cable in Woods Hole Harbor. In parallel a study of the optimum access methods and modulation and techniques was performed.  Results of the feasibility study showed that a non-invasive technique for inductive coupling is not feasible for use with existing SF and SD coaxial cable designs. Signals induced in both conductors by a toroid encircling the cable remain identical as they propagate along the cable as a result of mutual inductance. Thus, no signals are apparent at the repeaters. Optimal use of cable bandwidth combines time division multiple access with trellis-coded QAM modulation.			
<b>17. Document Analysis a. Descriptors</b>  1. ocean data telemetry 2. undersea cables 3. inductive coupling  <b>b. Identifiers/Open-Ended Terms</b>    <b>c. COSATI Field/Group</b>			
<b>18. Availability Statement</b>  Approved for publication; distribution unlimited.		<b>19. Security Class (This Report)</b> <b>UNCLASSIFIED</b>	<b>21. No. of Pages</b> 44
		<b>20. Security Class (This Page)</b>	<b>22. Price</b>