

Woods Hole Oceanographic Institution

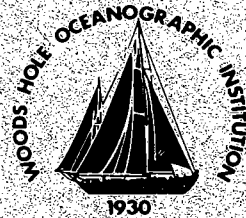

Effects of Solar Ultraviolet Radiation on Biogeochemical Dynamics in Aquatic Environments

Edited by

N.V. Blough and R.G. Zepp

January 1990

Technical Report

Funding was provided by the Environmental Protection Agency through an Assistance Agreement (CR-816171-01-0) and the Office of Naval Research through Grant Number N00014-90-J-1154.

Approved for public release; distribution unlimited.

DOCUMENT
LIBRARY
Woods Hole Oceanographic
Institution

WHOI-90-09

**Effects of Solar Ultraviolet Radiation
on Biogeochemical Dynamics in
Aquatic Environments**

Report of a Workshop
Marine Biological Laboratory
Woods Hole, Massachusetts
October 23-26, 1989

Edited by

N.V. Blough and R.G. Zepp

Woods Hole Oceanographic Institution
Woods Hole, Massachusetts 02543

January 1990

Technical Report

Funding was provided by the Environmental Protection Agency through an Assistance Agreement (CR-816171-01-0) and the Office of Naval Research through Grant Number N00014-90-J-1154.

Reproduction in whole or in part is permitted for any purpose of the United States Government. This report should be cited as:
Woods Hole Oceanog. Inst. Tech. Rept., WHOI-90-09.

Approved for publication; distribution unlimited.

Approved for Distribution:

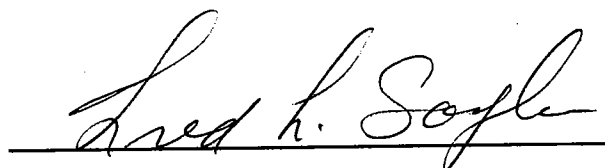

Frederick L. Sayles, Chairman
Department of Chemistry



Effects of Solar Ultraviolet Radiation on Biogeochemical Dynamics in Aquatic Environments

**Report of a Workshop
Marine Biological Laboratory
Woods Hole, Massachusetts
October 23-26, 1989**

Edited by N.V. Blough and R.G. Zepp

Co-Chairman:

Neil V. Blough	Richard G. Zepp
Department of Chemistry	Environmental Research Laboratory
Woods Hole Oceanographic Institution	Environmental Protection Agency
Woods Hole, Massachusetts 02543	Athens, Georgia 30613

Poster Co-Chairman:

Wayne Munns	Henry Lee
Environmental Research Laboratory	Environmental Research Laboratory
Environmental Protection Agency	Environmental Protection Agency
Narragansett, Rhode Island 02882	Narragansett, Rhode Island 02882

Support was provided by the Environmental Protection Agency through an Assistance Agreement (CR-816171-01-0) and the Office of Naval Research through Grant Number N00014-90-J-1154.



Contents

1	Introduction	1
2	Rapporteurs Reports	3
2.1	UV Radiative Transfer, Modeling, and Remote Sensing Anne Thompson	3
2.2	UV Effects on Atmospheric Chemistry in Condensed Phases T.E. Graedel	5
2.3	Field Observations of UV Effects on Chemical Processes in Natural Waters R.H. Gammon	7
2.4	UV Effects on Homogeneous Chemical Processes James W. Moffett	10
2.5	UV Effects on Heterogeneous Chemical Processes T. David Waite	12
2.6	UV Effects on Biological Processes Richard A. Larson	16
	Abstracts	17
3	UV Radiative Transfer, Modeling, and Remote Sensing	19
3.1	The Distribution of Ozone in the Atmosphere Paul D. Guthrie	19
3.2	Perturbations to UV Incident on Southern Hemisphere Oceans Following the Breakup of the Antarctic Ozone Hole Anne M. Thompson	22
3.3	How Might the Distribution of Cloudiness Change in Response to Global Warming? David A. Randall	28
3.4	Changes in Biologically Damaging Ultraviolet (UV) Radiation: Effect of Overhead Ozone and Cloud Amount Sasha Madronich	30
3.5	Remote Sensing of Marine Humus K.L. Carder, S.K. Hawes and R.G. Steward, K.A. Baker and R.C. Smith ..	33
3.6	Calculation of UV-B in Aquatic Systems and Possible Influence on Phytoplankton Communities R.C. Smith and K.S. Baker	36
4	UV Effects on Atmospheric Chemistry in Condensed Phases	39
4.1	Influences of Cloud Photochemical Processes on Tropospheric Ozone P.J. Crutzen and J. Lelieveld	39
4.2	Laboratory Investigations of Atmospheric Dimethylsulfide Oxidation P.H. Wine	42
4.3	Laboratory Studies Related to the Aqueous Chemistry of Clouds P. Warneck, H.-J Benkelberg and U. Deister	45
4.4	Aqueous-Phase Photochemical Sources of Oxidants in Clouds Bruce C. Faust and John M. Allen	48
4.5	Heterogeneous Photocatalysis on the Surface of Metal Oxides Michael R. Hoffmann	51

5	Field Observations of UV Effects on Chemical Processes in Natural Waters	56
5.1	Photochemical Production of Carbonyl Sulfide in Coastal and Open Ocean Waters Meinrat O. Andreae	56
5.2	Photochemical Production of Carbon Monoxide in Surface Waters of the Pacific and Indian Oceans R.H. Gammon and K.C. Kelly	58
5.3	Hydrogen Peroxide as a Relative Indicator of the Photochemical Reactivity of Natural Waters R.G. Zika	61
5.4	Effects of Solar Ultraviolet Radiation on Geochemical Dynamics: State-of-the-art in Molecular Probes for Reactive Transients Oliver C. Zafiriou	64
5.5	The Role of Photochemical Processes and Hydrogen Peroxide in Iron Redox Marine Chemistry Dana R. Kester	66
5.6	Chemical Reactions Affected by UV Irradiation in the Oceans and their Influence on Primary Productivity: Some General Considerations James W. Moffett	68
5.7	Phototransformation of Chemicals in Rice Paddies Donald D. Crosby	70
6	UV Effects on Homogeneous Chemical Processes	72
6.1	Effects of Solar Ultraviolet Radiation on Photochemical Processes in Natural Waters Richard G. Zepp	72
6.2	Optical Detection of Photogenerated Free Radical Intermediates in Natural Waters Neil V. Blough	77
6.3	Photochemistry of Dissolved Organic Matter: An Organic Geochemical Perspective John R. Ertel	79
6.4	Survey of Sunlight-Produced Transient Reactants in Surface Waters Werner R. Haag and Theodore Mill	82
6.5	Estimated Effects of Indirect Photolysis on Marine Organisms Theodore Mill, Werner Haag and Deneb Karentz	89
6.6	Photoreduction of Chromium in Natural Waters George R. Helz and Robert J. Kieber, Jr.	94
6.7	Effects of Solar UV-radiation on Hydrogen Peroxide Content and Radical Self-purification Processes in Surface Natural Waters Y. Skurlatov	96
7	UV Effects on Heterogeneous Chemical Processes	97
7.1	Photoprocesses Involving Colloidal Iron and Manganese Oxides in Aquatic Environments T.D. Waite	97
7.2	Photolysis of Contaminants on Soils and Sediments Glenn C. Miller	102
7.3	Effects of Sunlight and Anthropogenic Alterations in Atmospheric Solar Attenuation on Manganese Redox Cycles in Surface Seawater William G. Sunda and Susan A. Huntsman	104

7.4 Sunlight-dependent Changes in the Pigment Content and Spectral Characteristics of Particulate Organic Material Derived from Phytoplankton James R. Nelson	108
7.5 Indirect Effects of UV Radiation on Phytoplankton F.M.M. Morel and N.M. Price	110
8 UV Effects on Biological Processes	113
8.1 Biological Action Spectroscopy - Role in Estimating Effects Due to Stratospheric Ozone Depletion Thomas P. Coohill	113
8.2 UV-B Effects on Plants, Herbivores, and Phytopathogens Richard A. Larson	116
8.3 Photosensitization and Singlet Oxygen Toxicity Thomas A. Dahl	121
8.4 Bromoform Production by Marine Macroalgae; the Role of Vanadium Bromoperoxidases R. Wever, B.E. Krenn, M.G.M. Tromp and G. Olafsson	126
8.5 Dimethylsulfide Production - Effects of UV-B and PAR on Heterogeneous Phytoplankton Populations H. Gucinski, T.S. Bates, A.G. Wones and M. Behrenfeld	129
8.6 Impact of UV-B (290-320 nm) Radiation on Metabolic Processes of Marine Phytoplankton G. Döhler	133
8.7 Ultraviolet Radiation in Antarctic Waters: Particulate Absorption and Effects on Photosynthesis B.G. Mitchell, M. Vernet and O. Holm-Hansen	135
8.8 Ecological Considerations of the Antarctic Ozone Hole in the Marine Environment Deneb Karentz	137
8.9 Potential Effects of Solar Ultraviolet Radiation on Antarctic Phytoplankton S.Z. El-Sayed, F.C. Stephens, R.R. Bidigare and M.E. Ondrusek	141
9 Presented in Absentia	143
9.1 Ozone Depletion and Greenhouse Warming Alex E.S. Green	143
9.2 Laser Thermo-optical Methodologies for Environmental Analysis J.F. Power	148
9.3 Photoproduction of Hydroxy Radicals at the Sea Surface and its Potential Impact on Marine Processes Kenneth Mopper and Xianliang Zhou	151
10 Posters	158
10.1 Primary Productivity in the Southeast Pacific Ocean: Effect of Enhanced Ultraviolet-B Radiation Michael Behrenfeld, John Hardy, Hermann Gucinski and Andrew Wones	158
10.2 Mechanistic Investigations of the Novel, <i>Non Heme</i> Vanadium Bromoperoxidases: Evidence for Singlet Oxygen Formation Alison Butler, R.R. Everett and J.R. Kanofsky	159
10.3 Pure Singlet Oxygen Toxicity in Mammalian Cells Thomas A. Dahl, W. Rogert Midden, James E. Klaunig and Randall Ruch	162

10.4	Effect of UV-B Irradiance on ¹⁵ N-Nitrate Utilization by Synchronized <i>Synedra planctonica</i> G. Döhler and I. Biermann	163
10.5	A Biological Dosimeter to Evaluate the Transmission of Ultraviolet Radiation in Aquatic Environments Deneb Karentz and Louise H. Lutz	164
10.6	Fluorescence Detection of Carbon-Centered Radicals in Aqueous Solution David J. Kieber and Neil V. Blough	165
10.7	Photochemical Source of Biological Substrates in Seawater: Implications for Carbon Cycling David J. Kieber, Julie McDaniel and Kenneth Mopper	166
10.8	Variations of Peroxide in the Sargasso Sea William L. Miller and Dana R. Kester	167
10.9	Abiotic Formation of Formaldehyde, Acetaldehyde and Glyoxylate from UV-B Induced Photodegradation of Humic Substances in Natural Waters Kenneth Mopper and Robert J. Kieber	169
10.10	Light-Dependent Degradation of Phytoplankton Pigments James R. Nelson	176
10.11	EPR Studies of Hydroxyl Radical Formation from Photolysis of Aqueous Solutions of Humic and Fulvic Acids Barrie M. Peake and Neil V. Blough	177
10.12	Biological Effects of Ozone Depletion on Antarctic Aquatic Environments Mary A. Voytek	178
10.13	Photochemistry of the Eastern Caribbean Oliver C. Zafriou	179
10.14	Photosensitized Formation of Carbonyl Sulfide in Sea Water R.G. Zepp and M.O. Andreae	180
Appendix I - Program		181
Appendix II - List of Attendees		189

List of Figures

3.1.1	A typical vertical profile of ozone density.	19
3.1.2	The distribution of total ozone in time and space.	20
3.1.3	Halley Bay Ozonesondes.	21
3.2.1	Tropospheric oxidant changes corresponding to a 10% loss in stratospheric ozone.	23
3.2.2	December Southern Hemisphere ozone.	24
3.2.3	Polar-centric contour plot of Southern Hemisphere ozone from TOMS, for 4 December 1985.	25
3.2.4	Difference between oxidant levels and reduced sulfur species at 48°S with uv exposure 179 DU (4 Dec. 1985) and 278 DU (Dec. 1979–1982 mean).	26
3.4.1	Percent change in daily dose for DNA damage.	32
5.1.1	Means and standard errors for COS and average light intensity data from the North Atlantic cruise.	57
5.2.1	Cruise tracks in the North and South Pacific and Indian oceans during the period 1986–1989.	59
6.1.1	Action spectra for oxygenation (singlet oxygen formation) and diene isomerization (triplet formation) in natural water sample.	74
6.1.2	Wavelength dependence for the photochemical formation of hydrogen peroxide in natural water samples.	74
6.4.1	Photochemical pathways for transient formation in surface waters.	84
8.5.1	DMS incubation experiments.	130
8.5.2	Treatment (DMS) vs. dark (DMS)	130
8.5.3	DMS and phytoplankton AITS 89 cruise.	131
8.7.1	The spectral absorption coefficient of marine particulates ($a_p \text{ m}^{-1}$) from 300–700 nm for a station with a high $a_p(330)$ and a low $a_p(330)$ relative to the absorption of photosynthetic pigments from 400–700 nm.	136
9.1.1	Anthropogenic emission problems to atmosphere.	144
9.1.2	Greenhouse spectral region.	146
9.3.1	Steady-state $\cdot\text{OH}$ concentrations in sunlight irradiated Sargasso Sea water plotted against sampling depth, and profile of DOM fluorescence at the same station.	154
10.9.1	Sunlight-induced photoproduction of formaldehyde, acetaldehyde and glyoxylate as a function of initial fluorescence (excitation 360, emission 460) in a variety of natural waters.	171
10.9.2	Apparent quantum yield for formaldehyde and hydroxy radical production in natural waters as a function of irradiation wavelength.	172
10.9.3	(A) Apparent quantum yield for photobleaching of absorbance in Everglades water (mixed 1:1 with Sargasso seawater) as a function of irradiation wavelength (5 nm bandwidth). (B) Difference in absorption spectra before and after irradiation of Orinoco River water.	173

List of Tables

3.2.1	Unperturbed Composition of Model Marine Regions.	23
3.2.2	Parameters for Ozone Hole Perturbed UV Calculation	25
5.1.1	Average COS Concentrations and Fluxes for the World Oceans.	57
6.4.1	Kinetic and Concentration Data for Transients in Surface Water	83
9.3.1	Measured and Estimated OH Steady-State Concentrations and Fluxes in Sunlight Irradiated Seawater and Freshwater.	153
10.9.1	Net Photochemical Production Rates (\pm SD) of Formaldehyde, Acetaldehyde and Glyoxylate in Natural Water Samples.	170

1 Introduction

Anthropogenic activities are producing global increases in the atmospheric concentrations of various trace gases, including carbon dioxide, methane, nitrous oxide, chlorofluorocarbons, and carbon monoxide. These increases are likely to cause regional changes in the stratospheric ozone layer and in cloud cover that will affect the exposure of ecosystems to solar ultraviolet radiation. The dramatic decrease in stratospheric ozone over the antarctic during the austral spring provides a striking example of the impact that release of anthropogenic trace gases (in this case, chlorofluorocarbons) can have on Earth's atmospheric chemistry. The changes in ground-level UV radiation that accompany changing cloud cover and stratospheric ozone levels may have serious consequences for numerous biological and geochemical cycles that are critically important to the well-being of the biosphere. Moreover, because carbon dioxide, nitrous oxide, methane, halocarbons, carbon monoxide and carbonyl sulfide all have natural sources and sinks in the biosphere, alterations of the biogeochemical cycles could introduce significant positive or negative feedbacks to the atmospheric concentrations of these important trace gases.

To better assess the possible ramifications of changing UV levels on biogeochemical dynamics, this workshop assembled a diverse group of experts, including atmospheric chemists and physicists and aquatic chemists, biochemists and biologists. Participants were asked to help identify and more clearly define: (i) the potential effects of climate change on ground level solar UV (and visible) radiation, (ii) the impacts of solar UV radiation on geochemical processes in aquatic systems and (iii) the effects of solar UV radiation on biological processes, with emphasis on the possible effects of enhanced UV-B (280–320 nm) radiation. Participants were asked to discuss experimental and theoretical approaches to better characterize and model these processes on both regional and global scales. Questions that were addressed at the workshop included:

1. What factors affect the transmission of solar ultraviolet radiation through the atmosphere and aquatic environments?
2. How are chemical processes in the troposphere and in clouds affected by increases in solar ultraviolet radiation?
3. How does ultraviolet light affect aquatic biogeochemical sources and sinks of gases important in global change?
4. What do field studies indicate about which geochemical processes in the hydrosphere are most influenced by present levels of solar ultraviolet radiation? How will these processes be affected by projected changes in the ground level solar UV flux that accompany changes in stratospheric ozone and cloud cover?
5. How can remote sensing be used to help evaluate large scale oceanic phenomena affected by solar ultraviolet radiation?
6. How does solar ultraviolet radiation change the spectral properties of marine organic matter? What are the implications of such changes for remote sensing and penetration of biologically-damaging UV-B into the sea?

7. What (abiotic) photochemical processes are important in the hydrosphere and how significantly will these processes be influenced by changing UV-B fluxes?
8. What are the impacts of UV and UV-induced geochemical processes on aquatic biota?

To address the questions, the workshop was organized around six sessions of oral presentations:

- I. UV Radiative Transfer, Modeling and Remote Sensing
- II. UV Effects on Atmospheric Chemistry in Condensed Phases
- III. Field Observations of UV Effects on Chemical Processes in Natural Waters
- IV. UV Effects on Homogeneous Chemical Processes
- V. UV Effects on Heterogeneous Chemical Processes
- VI. UV Effects on Biological Processes

In addition, a poster session allowed participants an opportunity to present their results in more detail. After completion of the presentations, the participants in each of these six sessions separated into working groups. Rapporteurs assigned to each of these groups were asked to summarize the evidence and recommendations of their group and report their findings before the entire workshop. This report presents the written summaries of the Rapporteurs as well as the extended abstracts of the oral and poster presentations, which provided the basis for the Rapporteurs' conclusions. A concise summary of this diverse workshop is difficult, but perhaps useful. As with most situations in biogeochemistry, a change in one of the major driving forces, in this case the flux of ultraviolet light, will inevitably result in a transformation into a new regime. Some processes will be enhanced, some will be constrained. Some organisms will be favored, others will not. Hence, there is no simple answer to the question of whether enhanced UV radiation will produce good or bad results. What is certain is that it will produce a different global ecosystem, one that is responding not only to changing UV, but to changes in many other parameters of its environment as well. The interlocking puzzles involved are many, and bright, energetic people are working hard to sort out the pieces. A preliminary account of the proceedings of this workshop has been published by T.E. Graedel (*Nature*, **342**: 621-622, 1989).

Neil V. Blough
Richard G. Zepp

January 1990

2 Rapporteurs Reports

2.1 UV Radiative Transfer, Modeling, and Remote Sensing

Anne M. Thompson
National Atmospheric and Space Administration
Goddard Space Flight Center, Code 916
Atmospheric Chemistry and Dynamics Branch
Greenbelt, MD 20771

Paul Guthrie reviewed information on the distribution of ozone in the atmosphere. Seasonal and latitudinal patterns of total ozone were presented and the roles of photochemistry and dynamics in determining the distributions were explained. The highest total ozone values occur in the Northern Hemisphere springtime. Much lower ozone depths are seen in the Southern Hemisphere at high latitudes.

This basic ozone climatology can be seen in observations from the Total Ozone Mapping Spectrometer (TOMS), an instrument on the NIMBUS-7 satellite, that has been orbiting since 1979. Averaging 1979 and 1980 ozone over a two-year period eliminates most traces of a dynamical "quasi-biennial oscillation", and gives a reference point for ozone changes during the past decade.

A comparison of ozone maps taken from 1986 and 1987 TOMS shows a 4–10% loss in Northern Hemisphere ozone north of 70° in the winter. The pronounced Antarctic "ozone hole" maximizes in October south of 70° S, but a negative ozone trend in 1986–1987 relative to 1979–1980 (10% or more) is evident during all months south of 50°.

Two-dimensional photochemical dynamic models are able to capture the basic latitudinal and seasonal distributions of total ozone, but so far do not resolve interannual variability and cannot simulate the "ozone hole" with only gas-phase chemical reactions. Current projections of global mean ozone depletions 50–75 years from now vary from -9% (current CFC emissions, no controls) to -5% (Montreal protocol, 50% cutback in CFC production) to a -3% (95% cutback).

Anne Thompson calculated changes in UV and visible radiation in the troposphere, assuming 10% ozone depletion in the stratosphere. The perturbed and unperturbed radiation fields are used to calculate photodissociation rates (and chemical composition) in a model which gives vertical profiles of tropospheric trace gases. At the low ozone, low NO_x and CO environments typical of the marine boundary layer, a stratospheric ozone depletion of 10% would lead to 5–10% decreases of tropospheric ozone because of enhanced UV destruction in the process. $O_3 + hv(300 \text{ nm}) \rightarrow O_2 + O(^1D)$. At the same time concentrations of the highly reactive oxidants OH and H₂O₂ would be increased 5–10%.

A 10% loss in stratospheric ozone has actually been observed throughout the Southern Hemisphere in December since 1985 relative to ozone in the Decembers of 1979–1982. This is after the breakup of the "ozone hole" over Antarctica, but represents a lingering "imprint" of ozone loss. During 1985, however, post "ozone-hole" air masses of low ozone (<275 D.U.), moved out from Antarctica and exposed large sections of the Southern Hemisphere oceans to twice the amount of UV they experienced in 1979–1982. This UV perturbation would give rise to a tropospheric ozone loss of 20–30%, after several weeks, and OH and H₂O₂

increases of 20–30% in a few days. The oxidation rate of sulfur compounds (DMS, SO₂, H₂S) would be enhanced by a buildup of OH and H₂O₂.

Sasha Madronich computed UV fields on a climatological basis and also calculated the daily DNA damage dosage. For one set of scenarios of ozone depletion (corresponding to a 10% global ozone loss from 1980–2060) the ozone-induced changes in DNA daily dose were as follows:

Tropics	-5% to +10%
Mid-Latitudes	-5% to +20%
Northern Polar Region	+10% to +30%
Southern Polar Region	+100% to +1000%

Madronich also considered the perturbations that climate-perturbed cloud changes would induce in the UV-radiation field. Assuming a globally uniform + 2K change in SST (sea surface temperature), the effects would be as follows:

Tropics and Mid-Latitudes	0 to +5%
Summer Mid-to-High Latitudes	0 to -30%

The results are strongly sensitive to how aerosol effects are treated and are strongly model-dependent. Given sets of CFC scenarios were specified in two 2D photochemical models (WISCAR + GSFC2). So far climate perturbations have been incorporated into two climate GCM's. Additional models are being used for the same scenarios and this study is producing model intercomparison for these cases.

K. Carder discussed the possibility of quantifying aquatic humus by remote sensing as a possible means to examine the mesoscale variability of dissolved organic constituents, which may covary with aquatic humus within certain oceanic regimes. In the past, absorption effects attributable to chlorophyll *a* could not be de-convolved from those due to pigment degradation products, phaeophytin *a* and aquatic humus, because the wavelengths monitored by the Coastal Zone Color Scanner were not in the range where significant differences existed between the spectral absorption curves for chl *a* and the degradation products. Carder presented a new algorithm employing spectral bands at 410, 440 and 560 nm to separately quantify chl *a* and the degradation products. Initial results in irradiance reflectance data from California Current waters indicates that this algorithm reduces the error in estimating chl *a* from more than 200% to less than ±50%.

R.C. Smith reviewed the information required to calculate 1) the levels of spectral irradiance reaching the earth's surface, 2) the changes in these levels that result from alterations to the earth's atmosphere, 3) the downward spectral irradiance at any underwater depth and 4) the biological weighting function for damage, $\epsilon(\lambda)$. Estimates of the biological consequences of increased UV for aquatic organisms can be calculated with knowledge of these factors. However, a key uncertainty remains in the choice of the biological weighting function to be used in a particular situation. (The difficulties in obtaining appropriate weighting functions is discussed by T.P. Coohill (*vide infra*).) Direct determination of effects on natural populations have not been made although estimates range from insignificant to catastrophic.

2.2 UV Effects on Atmospheric Chemistry in Condensed Phases

T.E. Graedel
AT&T Bell Laboratories
Murray Hill
New Jersey 07974

Atmospheric chemistry is driven by absorbed solar radiation, and especially by photons in the ultraviolet spectral region. Concentrations of chemical species are changing, and the ultraviolet spectrum to which they are exposed is changing as well. Models (paper by Madronich) predict that UV at the surface and in the lower troposphere will change significantly in the future. For mid and low latitudes, UV-B changes are predicted to be -5% to 10%, depending on the model and on the assumed scenario. For southern polar regions, much larger increases in springtime UV are expected (as much as a factor of 10 in the year 2060), and a doubling of springtime UV is believed to have already occurred in recent years (see the ozone measurements presented by Guthrie).

The past decade has produced significant advances in the knowledge of the chemistry of condensed phases in the atmosphere. These advances were exemplified by the four papers presented in the condensed phase chemistry session of the workshop. Crutzen reported that the addition of condensed phase processes to a gas phase atmospheric chemical model caused significant changes in the computed concentrations of gas phase ozone and other species. It appears obvious that when condensed phases are present, their direct chemical influence on gas phase chemistry should be considered in any atmospheric chemical calculation. Warneck reported on laboratory experiments involving the reactions of sulfur oxyanion radicals in aqueous solution and the photosensitivity of iron (III) solution complexes to solar ultraviolet radiation. His paper made it clear that free radical chemistry is crucial to solution processes, both in the presence and absence of ultraviolet radiation. Faust discussed his photochemical experiments with authentic cloud waters, the experiments being designed to establish the aqueous phase photochemical sources and concentrations of free radicals and excited state molecules in cloud droplets. His results imply a much more vigorous and diverse chemistry than has traditionally been considered. Hoffmann presented laboratory results on the generation of free radicals in solution as a consequence of heterogeneous catalysis on the surface of solid metal oxides, a type of material common in atmospheric condensed phases. It seems likely that the processes are occurring in the atmosphere, and assessments of their importance are desirable.

Among the recent rapid advances in condensed phase chemistry, some of which were mentioned in the panel discussions following the workshop presentations, are the following:

- The atmospheric radiation budget is now known to rather good accuracy on a global basis, as is the wavelength distribution of the radiation entering and leaving the atmosphere at various altitudes. However, at any one location and any specific time the radiation input is relatively uncertain, as a consequence of uncertainties and lack of measurements dealing with the presence and physical properties of clouds.
- Condensed phase chemistry is important to gas phase atmospheric chemistry. Examples include (1) the widely recognized fact that sulfur dioxide is oxidized predominantly in the aqueous phase, where it is generally the principal determinant in

precipitation acidity, (2) the recent theoretical evidence (see Crutzen, this report) of significant ozone loss to the condensed phase, and (3) model results and experimental evidence that the cycling of polar organics is controlled by condensed phase processes. Thus, atmospheric chemical analyses that do not include condensed phase processes have the potential for being inherently inaccurate.

- Condensed phase chemical processes in the atmosphere are quite sensitive to oxidizing species supplied from the gas phase (see the papers by Crutzen and Warneck), as well as to species formed from the interactions of solar ultraviolet photons with constituents of the condensed phase (see the papers by Faust and Hoffmann).
- Changes in the concentration of gas phase ozone will change the atmospheric radiation budget (see the paper by Madronich), a process that has dramatic effects for the concentrations of atmospheric oxidizing constituents (see the paper by Thompson). Both of these changes will significantly affect condensed phase atmospheric chemistry. Our understanding of that chemistry is too sketchy at the present time to predict how the changes will manifest themselves, however.

In order to become more quantitative in anticipating changes to condensed phase chemistry as a consequence of changes in atmospheric UV, we have identified three major needs for the atmospheric science community to address:

- Defining with precision the current UV flux (both horizontal flat plate, and "spherically integrated" actinic flux) as a function of time and location. Present atmospheric chemical models are constrained in specifying ultraviolet flux levels by uncertainty associated with cloud effects on the UV flux. The models would benefit markedly from a long term UV monitoring network, which could usefully be implemented by augmenting current instrument and site capabilities.
- Because clouds are so important in gas and condensed phase atmospheric chemistry, cloud parameter information beyond that related to the ultraviolet radiation flux is also badly needed. Among the parameters that are poorly defined are cloud vertical distributions, cloud morphology, liquid water content, chemical makeup, opacity, formation and dissolution cycling, and ventilation capacity. Much of this information is either not available or not well specified by orbiting satellite observations. A few well-designed and continuing field study programs are needed to better define cloud physical and chemical properties in the first several kilometers above the Earth's surface.
- Among the uncertainties in condensed phase atmospheric chemistry, perhaps the greatest is the content of free radicals. The uncertainties include the degree to which free radicals are supplied to the condensed phase from the gas phase and the degree to which free radicals are generated *in situ* from photochemical and thermal processes. Determining free radical concentrations in authentic samples will probably involve innovative chemical probe techniques. A few well-chosen programs in this area of research would be well worth the investment.

2.3 Field Observations of UV Effects on Chemical Processes in Natural Waters

Richard H. Gammon
School of Oceanography
University of Washington
Seattle, Washington, 98195

The first two papers summarized the field data for the abiotic, photochemical production of carbonyl sulfide and carbon monoxide and the importance of the global average flux of these gases from the sea to the atmosphere.

M. Andreae presented a new budget for the abiotic, photochemical production of OCS from the global ocean ($0.35 \text{ Tg S yr}^{-1}$), dominated by coastal waters. In a related poster presentation by Zepp and Andreae, the process of photosensitized oxidation of dissolved organic sulfur to produce OCS was explored as a function of wavelength, particular organic sulfur compounds and DOM of marine and riverine origin.

R. Gammon reviewed the process and flux estimate for the abiotic, photochemical production of carbon monoxide from DOM in the surface waters of the world ocean. Measured supersaturation as high as $\times 50$ were observed in productive upwelling areas in the eastern equatorial Pacific and in frontal regions ($35\text{--}40^\circ$ latitude) in both the North and South Pacific and Indian oceans. The diel cycle for CO in the surface waters is similar to that presented for OCS by Andreae, with increasing concentration during sunlit hours with a peak in mid to late afternoon. The global CO flux to the atmosphere may be $200 \text{ Tg CO yr}^{-1}$ or higher, and could account for a major fraction of the apparent loss rate of refractory DOM from the global ocean.

The following three presentations focussed on aspects of the process of photochemical production and subsequent reaction of high energy transients in natural, sunlit waters. R. Zika stressed the value of hydrogen peroxide as a relative indicator of the photochemical reactivity of natural waters. Although the local surface water concentration of H_2O_2 has been observed to vary over the range 0–1000 nm, the highest levels and highest formation rates occur in coastal waters where the poorly characterized photosensitizing components of the dissolved organic matter are more likely to originate from terrestrial humic sources. H_2O_2 is a dominant product in the reaction of the key photochemical intermediate O_2^- , and more easily tracked as an indication of the local photochemical reactivity than excited state molecular oxygen ($^1\Delta_g \text{O}_2$), which has a lifetime of only microseconds in water. Measurements of the spatial and temporal variations of H_2O_2 must be combined with concurrent determinations of spectral irradiance as a function of depth and wavelength and interpreted within the context of a realistic model of the dynamics of the mixed layer.

O. Zafiriou reviewed the molecular probe approach to determining the rates of photochemical reaction in natural waters involving a range of reactive transients (singlet oxygen, high energy triplets, primary radicals, alkyl, acyl, OH, and O_2^-). While focussing the discussion on photochemical processes in natural waters and the changes in these processes in response to changing UV-B flux, Zafiriou suggested that more significant changes are to be expected within cloud water droplets and at exposed surfaces of vegetation and soil, which have received less attention and are less well characterized. Field data for the tem-

perate/tropical marine environment suggested a rate of total radical formation for full noon insolation conditions in the range $0.2\text{--}20\text{ nM min}^{-1}$ (or $20\text{--}2000\text{ }\mu\text{M yr}^{-1}$ on an annual basis). The low resolution action spectrum for this radical formation resembles the absorption spectrum for "Gelbstoffe", with strong absorbance in the UV-B but still significant at longer wavelength. To make quantitative progress in this field, improved standardization and cross-calibration of methods employed by different investigators is required, as well as more convenient light sources for monochromatic UV and sun simulations.

D. Kester presented evidence for photochemical reduction of Fe(III) in upwelled sunlit waters and for concurrent oxidation of Fe(II) by oxygen and hydrogen peroxide. Fe(II) in natural waters is apparently stabilized in some unknown manner against rapid oxidation to Fe(III), relative to measured oxidation rates for added Fe(II) in laboratory studies. Given the importance of iron as a limiting nutrient in many eutrophic marine environments, the continual cycling of Fe(II)/Fe(III) mediated by sunlight and O_2 , H_2O_2 may provide a mechanism for maintaining iron in a form available for uptake by phytoplankton. Clearly, changes in the UV flux at the surface of the global ocean will alter the steady-state iron redox cycling and may well affect marine productivity.

J. Moffett discussed the bio-availability of photochemically reduced trace metals (Fe, Cu, Mn) in the marine environment in relation to primary production, and the changes which might occur in production and relative populations of phytoplankton species as a result of changing UV-B at the sea surface from a changing atmospheric ozone column. For stratified environments in which surface nutrients have been depleted by the marine biota, biologically important chemical reactions mediated by UV-B in the surface waters will only seriously impact the primary productivity peaking deeper in the water column if long term chemical perturbations are mixed to the lower photic zone. Under well mixed conditions (such as apply over much of the Southern Ocean currently subjected to increased UV-B in austral springtime due to the Antarctic "ozone hole") nutrient levels and primary productivity are high in the surface waters, and changing photochemical effects, including direct photo-inhibition of photosynthesis, promptly impact the biota and have greater impact on primary production. This may be especially true in regions where photoreduction of iron in surface waters limits local productivity. Smaller, prokaryotic phytoplankton have been shown to be more sensitive to their (trace metal) chemical environment than larger eukaryotic phytoplankton expected from changes in the photo-mediated trace metal concentrations in surface water which will accompany shifts in the UV-B reaching the surface of the Southern Ocean.

D. Crosby summarized the pathways and products for the direct and indirect photochemical degradation of synthetic organic molecules, such as herbicides often present at 10^{-4} M levels in rice fields. Direct photolysis leads to ring and sidechain oxidation of phenoxy herbicides such as MCPA, as well as reduction and photonucleophilic substitution. Indirect oxidation occurs via OH photochemically generated from natural solutes (e.g., NO_2^- , NO_3^- , H_2O_2). Since most pesticides used on rice have broad UV absorptions in the 290 nm range, any increase in the flux of such UV-B radiation reaching the ground, or shift of the solar spectrum toward shorter wavelengths, will directly increase the photochemical degradation rate of these herbicides, implying a decreased persistence in the environment and the need to increase the application rate to maintain the nominal effective field concentrations.

In a general review of this session on field measurements of UV effects on chemical processes in natural waters, the speakers addressed the question posed by the session chair, P. Brewer, namely, how can the results of a local photochemical, process-oriented field study be generalized and reliably extended to the global ocean. Before such extrapolations can be attempted, more detailed and comprehensive field experiments must be carried out in marine settings spanning a broad range of biological productivity to characterize the critical photochemical processes and intermediates. Such studies must bring together interdisciplinary teams currently working on photochemical processes on only one or the other side of the air-water interface through major national/international programs (JGOFS, IGAC, SCOR, IGBP). Important consequences of changing UV flux at the sea surface will include changes in primary production, species composition, and the climatically important fluxes of biogeochemically and photochemically generated trace gases from the sea to the atmosphere. The discussion and presentations clearly neglected the important microbial dark consumption of chemical species generated by daytime photochemical processes, but did suggest possible non-linear chemical responses to changing UV-B in the water column relating to changing UV penetration depths, thresholds for photochemical chain reactions, and photo-bleaching of poorly characterized chromophores. The highest experimental priority is for improved definition of the UV radiance within the water column as a function of depth and wavelength.

2.4 UV Effects on Homogeneous Chemical Processes

James W. Moffett
Department of Chemistry
Woods Hole Oceanographic Institution
Woods Hole, Massachusetts 02543

This session focused on three areas; an overview of our current knowledge of homogeneous photochemistry, particularly the production of transient species, recent advances in specific topics and speculation about how these processes might be biogeochemically important. The session consisted of 7 speakers; R. Zepp, N. Blough, J. Ertel, W. Haag, T. Mill, G. Helz and V. Skurlatov.

Zepp discussed experimental approaches to studying photochemically produced transients in natural waters. He focused on time resolved techniques for the direct spectroscopic detection of transients and contrasted this approach with continuous photolysis techniques involving chemical "probes" which react with transients via well defined, selective pathways. He showed data for solvated electron production obtained using time resolved and continuous photolysis techniques. There was a large discrepancy in the data, with production rate estimates several times greater for the time resolved measurements. Zepp pointed out that UV light is primarily involved in most transient photoproduction, providing impetus for evaluating how changes in UV irradiation will affect transient distributions.

Blough focused on the application of nitroxides as chemical probes for photochemically produced transients such as carbon-centered radicals. He described recent advances in optical detection of the resultant adducts, through linking the nitroxide covalently to fluorophores. These new methodologies make it possible to study transient species at low formation fluxes and steady state levels typical of most marine waters.

Ertel summarized his recent investigation of lignin photochemistry and its implications for the use of lignin as a tracer of terrigenous organic matter in seawater. Lignin is derived uniquely from terrestrial plants and is regarded as a good tracer, but Ertel showed that it may be preferentially photodegraded compared with riverine total dissolved organic matter. He discussed the implications of this observation for using lignin and its degradation products as tools of humic material photooxidation processes.

Haag presented a survey of photochemically produced transients, focusing on data obtained using chemical probes. He discussed techniques to calculate formation fluxes and steady state conditions and also some of the limitations of such probes because of lack of selectivity. For example furans, which are used as singlet oxygen traps, are also oxidized by radicals.

Mill evaluated the effects that production of photochemical transients would have on marine organisms using a simple model. He calculated the surface area for a "generic" organism and calculated a rate of oxidation of the organism's surface using steady state concentrations of strong oxidants such as OH and its immediate reaction products in seawater (such as the carbonate radical). He concluded that the production of radicals in bulk solution could contribute to the observed effects of UV light on aquatic organisms, but cautioned that the model was extremely simplistic at this stage.

Helz discussed observations on the photoreduction of soluble Cr(VI) to insoluble Cr(III) in estuarine waters. The reaction is particle dependent and may be mediated by Fe(II) produced photochemically. Helz suggested that this reaction could account for the relatively short residence time of Cr in natural waters and is an important reaction environmentally because Cr is highly toxic.

Skurlatov summarized much of the work being carried out in the USSR in this area, primarily by his group. Research has focused on H_2O_2 interactions with the biota and with transition metals. He observed that massive fishkills in Russian rivers were associated with low or negligible H_2O_2 levels, suggesting that some toxic component in the water was also reactive with peroxide. He also presented data showing how Cu catalyzes the autoxidation of H donor compounds in natural waters.

In the discussion that followed, the principal concern was how the processes would be affected by changes in UV flux, where the processes were likely to occur and how they might affect the biota. This revealed the major limitations of this primarily laboratory based data set. More data on action spectra are needed so that the variation of rate with depth and changes in UV flux can be established. Currently this is well known only for H_2O_2 generation. For photosensitized reactions, more information is required on the sources of the unknown chromophores, i.e., terrestrial vs. authigenic sources. Currently it is impossible to say how changes in oceanic productivity or input of riverine organic matter to the oceans affected by climate change would affect overall chromophore distributions. It was pointed out that in the current funding climate, emphasis is placed on field observations with the consequence that adequate laboratory studies to quantify these processes are not carried out. Many reactions involving photosensitization by organic matter (including the production of 1O_2 and most of the radicals discussed in this session) probably have action spectra which resemble the absorption spectra of DOM in seawater. If so, then the models for H_2O_2 production and distribution developed by Zika and coworkers should give useful insight into how increases in UV flux would change steady state levels of transients derived from DOM photosensitization.

Discussion of effects on the biota used the model presented by Mill as a springboard. The model placed severe constraints on how important photoprocesses in bulk solution could be. However, Mill focused on short lived highly reactive, nonselective radicals such as OH. The ultimate products of such species may influence specific processes in organisms in a much more selective way. Alternatively, such reactions may ultimately result in production or destruction of metabolites or other compounds which are actively taken up by organisms. Two examples cited were the photodecomposition of vitamin B12 and Cu chelators, destruction of the latter enhancing Cu uptake by organisms.

In the environment, as opposed to the photochemistry lab, photochemical and biologically mediated reactions are probably coupled, e.g., photolysis of a biologically refractory compound and subsequent microbial decomposition of the product. This complicates efforts to study the processes experimentally.

Validation of predictions based on laboratory measurements of UV effects will require more extensive field measurements than are currently available. Ultimately, satellite imagery may become a useful tool if relationships between potentially measurable parameters, such as DOM fluorescence and photochemically important properties such as the concentration of photosensitizers can be established.

2.5 UV Effects on Heterogeneous Chemical Processes

T. David Waite
Australian Nuclear Science & Technology Organisation
Lucas Heights Research Laboratories
New Illawarra Road
Lucas Heights, New South Wales
Australia

Summary of Presentations

Field and laboratory evidence for the involvement of light in dynamic changes in the speciation of iron and manganese in both marine and fresh waters was presented by T.D. Waite. Significant increases in the filterable manganese concentration present in surface waters in response to light input are observed because of the ability of light to both enhance the reductive dissolution of particulate manganese oxides and to retard the bacterially mediated oxidation of Mn(II). While similar diurnal cycling is evident for iron in low pH freshwaters where the abiotic oxidation of Fe(II) back to the oxidized particulate state is relatively slow, consistent evidence that measureable concentrations of Fe(II) in bulk seawaters are produced as a result of light is not available — presumably because of the rapid rate of oxidation of Fe(II) at such pH and, possibly more importantly, the tendency of reduced iron to remain sorbed to particulate iron oxide surfaces.

Despite the apparent lack of increase in “soluble” iron as a result of light-assisted dissolution of naturally occurring iron oxides in seawaters, UV light may induce a change in reactivity of iron oxides through the continual reformation of fresh ferric oxyhydroxides as a result of Fe(II) oxidation at the particle surface. Such transformations may have significance to the pollutant scavenging ability of colloidal iron oxides and to the availability of iron to phytoplankton because of the increased solubility of the oxyhydroxide. While light-assisted charge transfer within surface-located metal-organic complexes appears the most reasonable explanation for the ability of light to enhance colloid dissolution, much remains unknown concerning the mechanistic detail of light influenced heterogeneous redox transformations.

G.C. Miller described how a variety of chemical and physical effects could mediate photolysis of contaminants on particulate matter. These effects include light screening, energy transfer from the contaminant to underlying substrate, yield and product alteration due to surface effects and movement of contaminant into a light exposed area. Major issues surrounding these effects are noted below:

- Suspended sediments cause significant *light attenuation* with an average attenuation coefficient of 2.6×10^{-3} /mg found for a variety of sediment types.
- Humic substances — typically adsorbed to other particulate matter — have been shown to be *effective quenchers* of excited state molecules and, for example, may account for the stability of polyaromatic hydrocarbons on particulates such as fly ash.
- Inorganic and organic components of particulate matter may have a significant effect on the photochemistry of sorbed molecules with potentially significant effects

on the *product distribution*. For example, irradiation of octachlorodibenzo-p-dioxin (OCDD) on thin layers of soil resulted in formation of 2,3,7,8-tetrachlorodibenzo-p-dioxin (2,3,7,8-TCDD) — a toxic product not found on photolysis of OCDD in solution.

- Movement of photosensitive compounds into light exposed areas of the substrate will modify the rate and extent of photolysis. Such an effect is of particular importance in soil environments.

W.G. Sunda summarized the results of experiments indicating that both the photoinhibition of microbial Mn(II) oxidation and the photoreductive dissolution of Mn oxides decreases the accumulation of Mn oxide particles in near-surface seawater leading to a decrease in the removal of manganese from these waters due to particulate scavenging processes.

It is suggested that any anthropogenic alterations in the atmosphere leading to increased cloud cover (such as greenhouse warming or the release of cloud nuclei) should decrease the magnitude of these two photoeffects, resulting in a decrease in Mn retention in surface waters. Such effects may have an adverse effect on phytoplankton which require Mn for photosynthetic electron transport and for dismutation of toxic superoxide radicals. Increases in UV-B radiation due to anthropogenic ozone depletion, on the other hand, may have the opposite effect. Given the potentially opposing effects of increased cloud cover and ozone depletion, the overall effect of anthropogenic changes in atmospheric solar attenuation on Mn concentrations and biological availability in surface seawaters remains uncertain.

J.R. Nelson reported on the effects of near-UV and visible light on the pigment composition and on the spectral characteristic of organic detritus derived from phytoplankton. Examination of light-dependent rates of pigment photodegradation in laboratory studies indicated that the photooxidative degradation of phytoplankton chlorophylls, pheopigments and carotenoids contained in detrital particles would occur fairly rapidly in near-surface waters with the pigment photooxidations most likely occurring by a photosensitized mechanism. It is considered likely that such sensitized reactions might be enhanced due to the localization of the hydrophobic pigments within hydrophobic microenvironments in detrital particles.

Interestingly, it appears that algal pigment-derived chromophores dominate particulate absorption in many different waters including shallow, continental shelf waters and at least some open ocean waters. Assessing the potential effects of UV radiation on this "detrital" class of organic chromophores requires a better understanding of the chemical composition and photochemical activity of its constituents.

F.M.M. Morel suggested that, given the current knowledge base, one could argue that an increase in UV radiation would result in (a) an increase in new primary production, (b) a decrease in primary production, or (c) no discernible effect on primary production. The rationale behind each of these arguments is summarized below.

Increase in primary production: It may be argued that an increase in UV will enhance new production by making the limiting nutrient iron more available. In addition,

increased light may increase the availability and decrease the toxicity of other trace elements (particularly Mn, Cu, Co, Ni and Zn) through photoredox and complexation effects.

Decrease in primary production: It may equally be argued that increased UV will inhibit primary productivity because detoxification effects (for reactive intermediates) are trace element limited (for example, by selenium or iron). The direct photochemical effects on primary producers also cannot be ignored in this context.

No effect on primary production: Again, it may be argued that increased UV will have no effect on marine biota because the organisms are already adapted. In addition, the chemistry of the oceans is intrinsically self correcting (chemostatic). The real controls on primary productivity are fundamental physical (mixing) and chemical (reaction rates) processes.

Summary of Discussion

While the discussion of these papers was not lengthy, a number of points were highlighted or re-emphasized:

- While laboratory investigations of the photo-assisted dissolution of colloidal manganese oxides have been undertaken and models of this process developed, both the experimental arrangement and the model proposed have been far too simplistic. More specifically, synthetic colloidal oxides are an inadequate model of the dominant type of manganese containing particles found in natural waters, i.e., bacterial cells coated with amorphous manganese oxides.
- While the results of laboratory investigations suggest that measureable amounts of reduced iron will not be released to bulk solution at seawater pH as a result of photoredox processes, a number of workers have observed a diurnal increase in the concentration of either "filterable" iron or, in some cases, what has been termed "Fe(II)". While additional intercomparison studies and technique development are needed, it is likely that the observed diurnal cycling of iron reflects a light driven change in the "reactivity" of iron (i.e., it is proposed that light induces a continuing dissolution and reprecipitation of fresh amorphous iron oxide at the particle surface which will be more readily complexed by reagents such as ferrozine or 8-hydroxyquinoline).
- The lack of knowledge about the potential impact of increased UV on the primary producers represents a serious gap in our understanding.

Summary/Recommendations

Three major summary points/recommendations were made in connection with heterogeneous photoprocesses:

- While most reactive intermediates that are present in natural waters are both (a) too short lived, and (b) present at too low a concentration to induce major transformations in solution, the production of such species in heterogeneous environments,

where the diffusion length between reactants is typically short, may have significant consequences.

- Additional attention should be given to investigations into the nature and properties of particulates more typical of natural systems than the synthetic solids commonly used.
- In order to properly assess the effect of light on iron chemistry in seawaters, methods suitable for the assessment of particulate iron "reactivity" in marine systems need to be developed. In addition, intercomparison of the various methods available for measurement of "Fe(II)" in seawaters should be undertaken.

2.6 UV Effects on Biological Processes

**Richard A. Larson
Environmental Research Laboratory
University of Illinois
1005 Western Avenue
Urbana, Illinois 61801**

During the past decade we have learned a great deal concerning the interactions of UV-B radiation with living organisms. Perhaps surprisingly, there is much species specificity; some marine algae, for example, are rather susceptible even to current levels of UV-B, whereas other species show little apparent effect even at levels several times the current dose. The same sort of phenomenon is observed with terrestrial plants; in general among crop plants, corn is rather resistant, barley is of intermediate sensitivity, and beans are quite susceptible.

The mechanisms of genetic and phototoxic change to cells are beginning to be sorted out. Nucleic acids can be damaged by UV-B, either directly or indirectly by sensitizing mechanisms. Proteins also absorb UV-B, principally due to their content of tryptophan. Indirect damage can be caused by hydroxyl radicals, superoxide, and other reactive, oxygen derived transient forms generated by sunlight photolysis.

Obviously, these pathways of cell injury are also of concern to human health. Increases in UV-B have been calculated to lead to increased incidences of skin cancer, cataract development, and immune system damage.

The defensive responses of organisms exposed to increased UV-B have been examined in a few cases. The formation of defensive enzymes such as superoxide dismutase and catalase has been shown to be enhanced in some organisms, and antioxidant levels also increase in a number of cases.

Nevertheless, much research in this area is needed in the future. First of all, good data are required at the physicochemical level of study; what is actually happening to UV-B levels on a global level as ozone depletion proceeds, how does the UV-B actually penetrate into the waters where aquatic organisms live, what are the effects of UV-B on the chemical concentrations of vital nutrients such as vitamins and trace metals?

Biochemical knowledge needed includes an understanding of the importance of various possible cellular targets, the metabolic consequences of defense and repair strategies, and the relative importance of particular regions of the UV-B (and UV-A) spectrum to cellular response.

Studies of UV-B effects on whole organisms, whether microorganisms, plants, or animal species, are needed; these include lethal-versus-sublethal responses, the reasons for differences in species response, and the occurrence of mutations as related to other effects.

Finally, difficult but important studies on ecosystems or global effects need to be undertaken to answer questions such as latitudinal effects (is damage going to be mostly confined to the arctic regions?), effects on community structure and function, and whether UV-B stress will interact with other environmental changes such as global warming.

ABSTRACTS

3 UV Radiative Transfer, Modeling, and Remote Sensing

3.1 The Distribution of Ozone in the Atmosphere

Paul D. Guthrie
NASA/Goddard Space Flight Center
Atmospheric Chemistry and Dynamics Branch
Greenbelt, MD 20771

We normally speak of an ozone "layer" because the majority of atmospheric ozone molecules are located between roughly 20 and 35 km altitude. A typical vertical profile is shown in Figure 3.1.1 (from Watson et al., 1988). The vertical thickness and the altitude of the peak vary with latitude, and the tropospheric portion is highly variable in time and space.

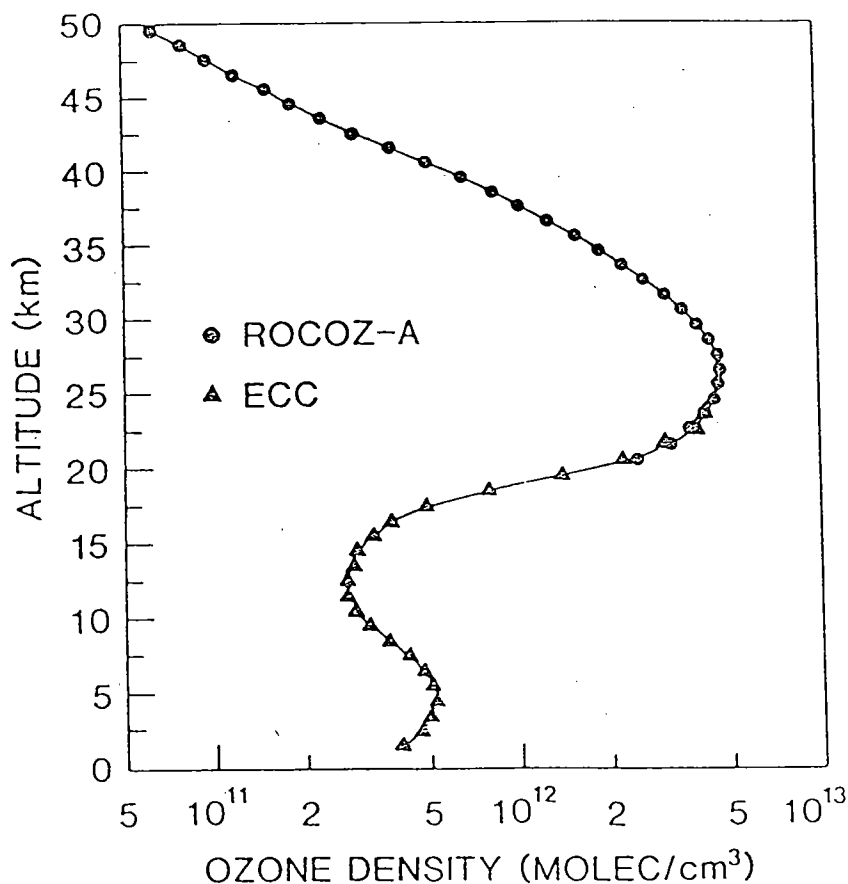

Figure 3.1.1: A typical vertical profile of ozone density.

The vertical integral of such a profile is termed column, or total, ozone. It is typically measured in dobsons, where 1 dobson = 1 milliatmosphere - cm. The global average ozone

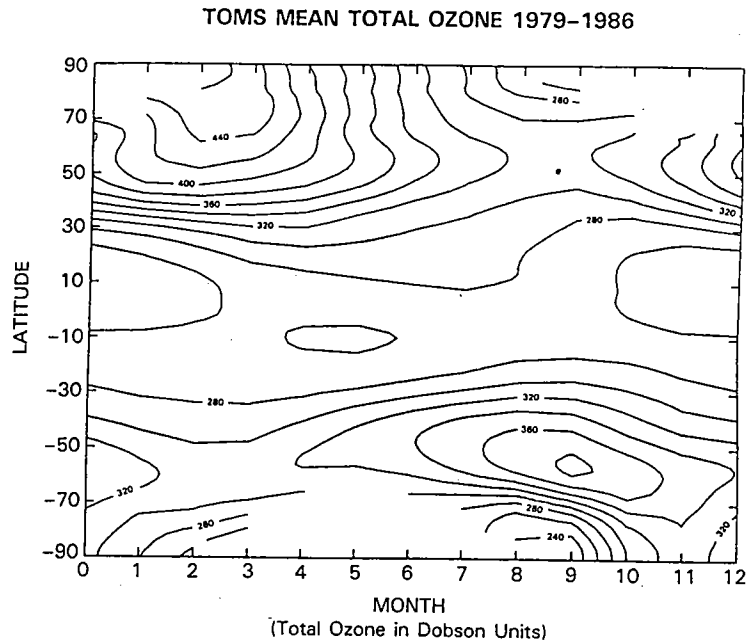

Figure 3.1.2: The distribution of total ozone in time and space.

column is roughly 300 dobsons, equivalent to a layer of pure ozone 3 mm thick at STP. The distribution of total ozone in time and space is illustrated in Figure 3.1.2. This represents the ozone column averaged around latitude bands over intervals of several days, as obtained from the Total Ozone Mapping Spectrometer (TOMS) aboard the Nimbus 7 satellite. The figure shows the average of seven years as a function of latitude and season. The pattern is one of minimal ozone with essentially no seasonal variation in the tropics, and maximum ozone with substantial seasonal variation at high latitudes.

Total ozone is known to be decreasing, as measured during the interval 1979-1988. The decrease is small ($\sim 1-3\%$), and of marginal statistical significance at low- and mid-latitudes, increasing poleward. Spectacular depletion of ozone takes place during the austral spring in the phenomenon known as the Antarctic ozone hole.

The ozone hole was first reported by Farman et al. (1985) and has since been the subject of intense investigation (see special issues: *Geophysical Research Letters*, **13**, 1986, and *Journal of Geophysical Research*, **24**, 1989). It occurs during September and October within a region confined by the meteorological Antarctic vortex. It is almost certainly related to heterogeneous chlorine chemistry enabled by the formation of polar stratospheric ice clouds. The destruction of ozone is confined to the layer between 17 and 25 km, in which ozone may be almost entirely removed during years when the hole reaches maximum depth (Figure 3.1.3). In December, when the vortex breaks up, the ozone distribution recovers to its normal shape. The degree of depletion varies from year to year, with a roughly biennial cycle, and has increased from 1979 to 1987. The depletion in 1989 appears to be identical to that in 1987, while 1988 was a year of moderate depletion, presumably due to meteorological conditions.

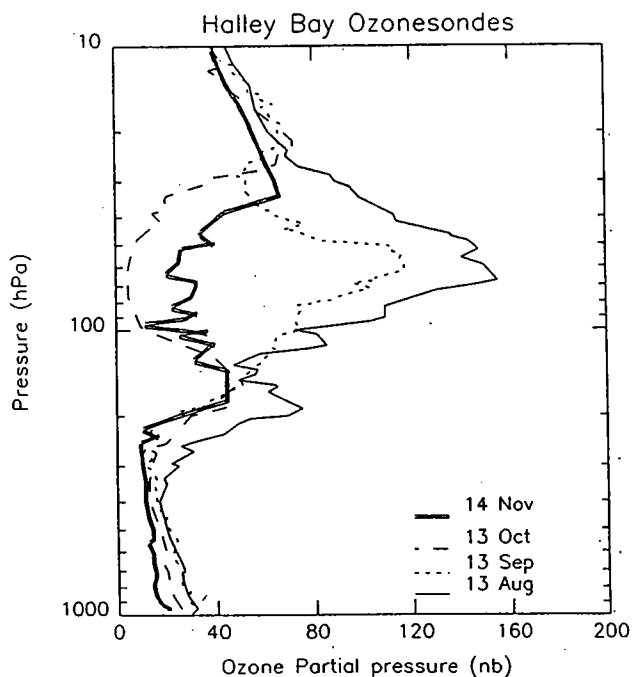

Figure 3.1.3: Halley Bay Ozonesondes. (Provided by P.A. Newman, based on data conveyed by B.G. Gardiner.)

Overall, for the regions of the earth not influenced by the ozone hole and barring other effects due to heterogeneous chemistry, we expect global ozone depletion to increase to levels ranging from 2% to 8% in global average. This range represents uncertainty in the future rate of emission of chlorine to the atmosphere, and does not include possible feedback effects due to climatic perturbations.

References

- Farman, J.C., B.G. Gardiner and J.D. Shanklin (1985). Large losses of total ozone in Antarctica reveal seasonal ClO_x/NO_x interaction. *Nature*, **315**: 207–210.
- Watson, R.T., M.J. Prather, M.J. Kurylo and panel members (1988). *Present State of Knowledge of the Atmosphere 1988: An Assessment Report*, NASA Reference Publication 1208.

3.2 Perturbations to UV Incident on Southern Hemisphere Oceans Following the Breakup of the Antarctic Ozone Hole

Anne M. Thompson
 National Atmospheric and Space Administration
 Goddard Space Flight Center, Code 916
 Atmospheric Chemistry and Dynamics Branch
 Greenbelt, MD 20771

Changes in ultraviolet radiation in the troposphere affect the rate of photodissociation reactions in the troposphere and can alter the equilibrium concentrations of the oxidants in the marine atmosphere: O₃, OH, HO₂, and H₂O₂ (hydrogen peroxide). These oxidants determine the photochemical lifetimes of trace gases emitted from sea to atmosphere (e.g., DMS, H₂S, CO) and the photochemical equilibrium among various species within the nitrogen, carbon and sulfur families. DMS (dimethylsulfide) may be a source of marine aerosol and a component in climate (Charlson et al., 1987).

We have used a one-dimensional model of tropospheric trace gas chemistry to evaluate potential changes in O₃, OH and H₂O₂ (and 26 other transients and trace gases) for specified depletions of stratospheric O₃ (Thompson et al., 1989). The perturbations are simulated by parameterizing the above-troposphere O₃ column in the computation of the uv and visible radiation field and photodissociation rates for 15 of the species in the model (Thompson and Cicerone, 1982; Thompson, 1984).

The calculations are performed with boundary condition representing several types of marine environments because the degree of chemical perturbation depends on the initial composition of a given region. Initial conditions for three regions, Northern Hemisphere marine mid-latitude, marine low-latitude and Southern Hemisphere mid-latitude, are given in Table 3.2.1. The sensitivities for O₃ and OH in the three regions are expressed in terms of coefficients of the form

$$\partial \ln[\text{O}_3(\text{trop.})] / \partial \ln[\text{O}_3(\text{strat.})] \text{ and } \partial \ln[\text{OH}(\text{trop.})] / \partial \ln[\text{O}_3(\text{strat.})].$$

The coefficient for tropospheric O₃ is negative and that for OH is positive because additional uv photolyzes O₃ and OH is formed:

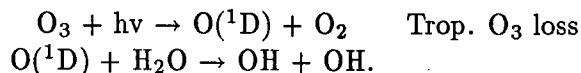

The changes in O₃, OH, and H₂O₂ corresponding to a 10% loss in stratospheric ozone are illustrated in Figure 3.2.1.

The scenario for a 10% stratospheric ozone depletion is not out of line with changes that have taken place over the Southern Hemisphere oceans over the past decade, judging from the December ozone record. Figure 3.2.2 shows zonal mean O₃ (taken from the NASA TOMS, Total Ozone Mapping Spectrometer, total column in Dobson units, DU) averaged over a month of December, after the ozone hole has broken up over the Antarctic continent. The years 1979–1982 have been averaged to give a baseline with which the subsequent years can be compared. In all but the most dynamically active years (e.g., 1988) there is 5–10% less ozone throughout the Southern Hemisphere in December 1985–1988 than the 1979–1982 average.

Table 3.2.1: Unperturbed Composition of Model Marine Regions.

Region	% Area (63°N-63°S)	Mixing Ratios (ppbv, 0 km)					Density	Sensitivity Coefficient ^a	
		NO _x	CO	O ₃	H ₂ O ₂	OH	$\frac{\partial \ln[\text{Trop. O}_3]}{\partial \ln[\text{Strat. O}_3]}$	$\frac{\partial \ln[\text{Trop. OH}]}{\partial \ln[\text{Strat. O}_3]}$	
Marine Mid-Lat. (45°N)	7.7	0.020	110	24	0.22	3.0 (5) ^b	-0.11	+0.86	
Marine Low-Lat. (15°N/S)	32.9	0.023	86	17	0.61	1.1 (6)	-0.34	+0.62	
Southern Hemis. (45°S)	21.1	0.021	66	25	0.22	5.2 (5)	-0.18	+0.85	

^aRef: Thompson et al., 1989.
^b3.0 (5) signifies 3.0×10⁵.

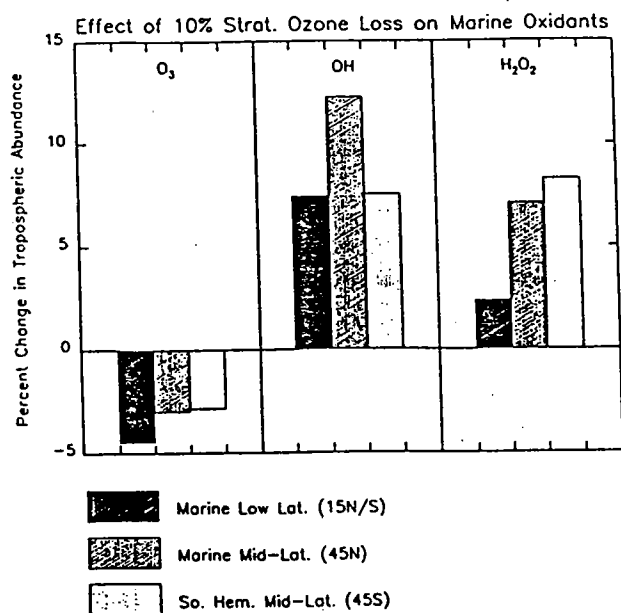

Figure 3.2.1: Tropospheric oxidant changes corresponding to a 10% loss in stratospheric ozone. Ozone loss is simulated in model with 10% loss of stratospheric column used in calculation of ozone photolysis rates.

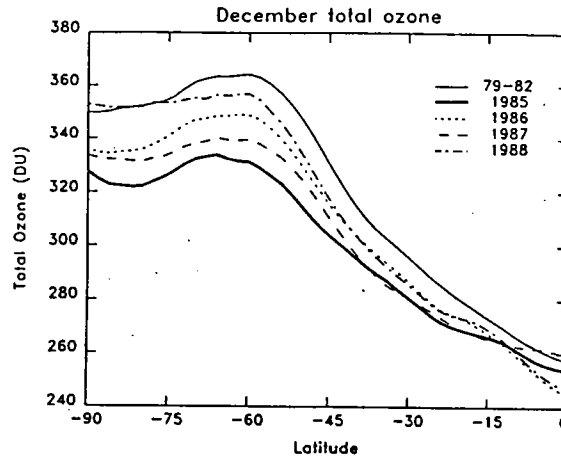

Figure 3.2.2: December Southern Hemisphere ozone. Zonally averaged ozone abundance (in Dobson Units) from TOMS satellite instrument.

A more extreme case of perturbed uv over the Southern Hemisphere oceans occurred in December 1985 during the Antarctic ozone hole break-up. An air mass of extremely low ozone (minimum <240 DU) moved northward to mid-latitudes and persisted into early December for several weeks, slowly moving eastward in the $0-90^{\circ}\text{E}$ region (Figure 3.2.3). We used the stratospheric O_3 column deduced from the TOMS satellite instrument to calculate uv (and chemical composition) at 48°S for December 4, 1985, where 234 DU were observed (Table 3.2.2). These results were compared to uv and chemical composition at the same latitude calculated from the more typical ozone column represented by the December 1979–1982 mean. The surface uv (as indicated by a comparison of $\text{O}_3 \rightarrow \text{O}(^1\text{D})$ photolysis rates) was 98% higher on December 4, 1985, than for the reference ozone column. Tropospheric ozone was calculated self-consistently by the model, with the profile obtained for December 4, 1985, similar to observed profiles at Halley Bay and Palmer Station.

The differences in O_3 , OH, and H_2O_2 abundances between December 3, 1985, and the December 1979–1982 reference amounts are shown in Figure 3.2.4. The changes are for an equilibrium composition, which in the case of ozone would take several weeks to achieve. For the more transient oxidants (OH and H_2O_2) the changes would occur on the time scale of hours–days. The photochemical lifetimes of sulfur gases in equilibrium with the perturbed oxidants would be decreased and lead to losses of DMS, SO_2 , and H_2S , assuming no change in the sea-to-air fluxes of these gases. The changes illustrated in Figure 3.2.4b show decreases in column abundance: DMS, -14%; SO_2 , -16%; H_2S , -24%.

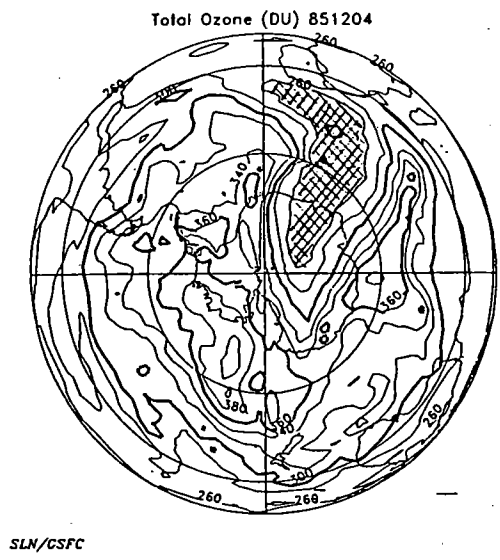

Figure 3.2.3: Polar-centric contour plot of Southern Hemisphere ozone from TOMS, for 4 December 1985. Cocontour interval, 20 DU. Shaded region is <260 DU.

Table 3.2.2: Parameters for Ozone Hole Perturbed UV Calculation^a

Year	Total O ₃ Column (TOMS)	O ₃ Column Above 15 km (Used in Model)	O ₃ (0 km) (From Model)
Dec. 1979–1982 (Mean)	333 DU	7.459×10^{18}	22.4 ppbv
Dec. 4, 1985	234 DU	4.809×10^{18}	15.8 ppbv

^aO₃ column above 15 km obtained from TOMS value less 55 DU, scaled with $2.6868 \times 10^6 \text{ cm}^{-2}$. Model uses solar zenith angle for 15 Dec., 48°S.

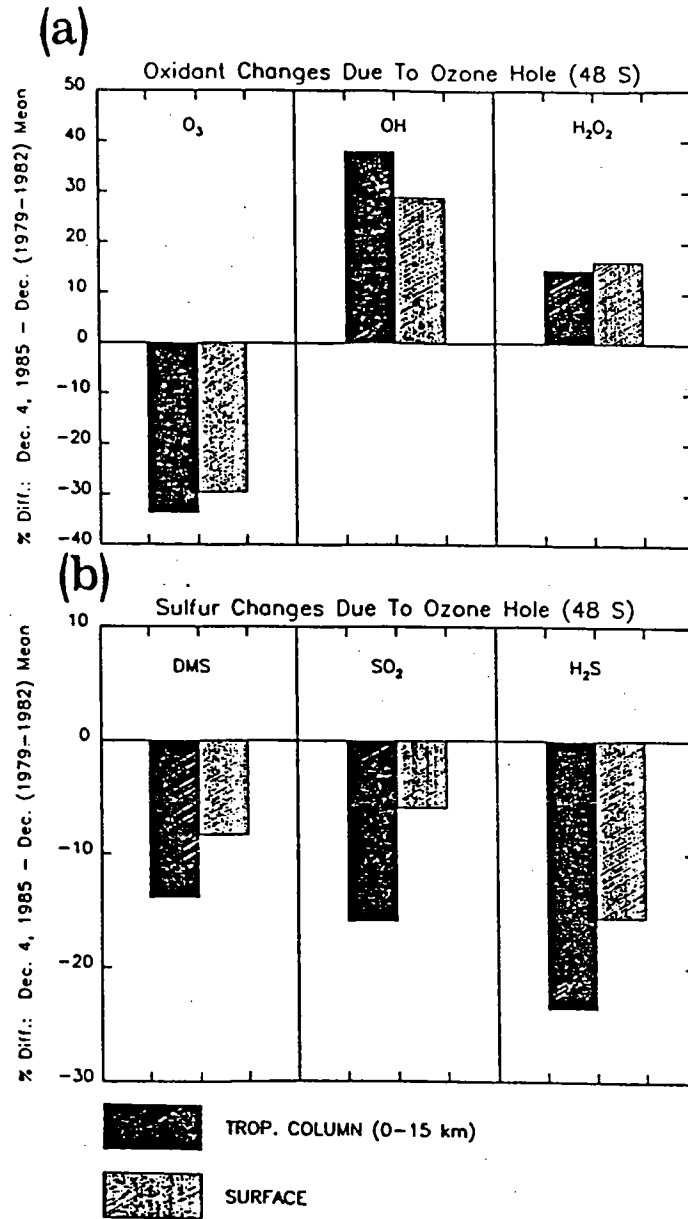

Figure 3.2.4: Difference between oxidant levels (a) and reduced sulfur species (b) at 48°S with uv exposure 179 DU (4 Dec. 1985), and 278 DU (Dec. 1979-1982 mean).

Acknowledgment

Thanks to Goddard colleagues Paul Newman and Mark Schoeberl for suggesting the model calculations and for providing the TOMS data. Mary Ann Huntley provided graphic assistance.

References

- Atkinson, R.J., W.A. Matthews, P.A. Newman and R.A. Plumb (1989). Evidence for the mid-latitude importance of Antarctic ozone depletion. *Nature*, **340**: 290-293.
- Charlson, R., J. Lovelock, M. Andreae and S. Warren (1987). Oceanic phytoplankton, atmospheric sulfur and climate. *Nature*, **326**: 655-661.
- Thompson, A.M. (1984). The effect of clouds on photolysis rates and ozone production in the unpolluted troposphere. *J. Geophys. Res.*, **89**: 1341-1349.
- Thompson, A.M. and R.J. Cicerone (1982). Wet and dry removal as causes of variability in the trace-gas composition of the marine troposphere. *J. Geophys. Res.*, **87**: 8811-8826.
- Thompson, A.M., R.W. Stewart, M.A. Owens and J.A. Herwehe (1989). Sensitivity of tropospheric oxidants to global chemical and climate change. *Atmos. Environ.*, **23**: 519-532.

3.3 How Might the Distribution of Cloudiness Change in Response to Global Warming?

David A. Randall
Department of Atmospheric Science
Colorado State University
Fort Collins, Colorado 80523

It is well known that the climatological distribution of cloudiness can change significantly in a global warming event (Charney, 1979; Smagorinsky, 1982). Of the numerous studies addressing this point, virtually all have emphasized the problem of determining the positive or negative feedback that cloudiness changes would exert on the warming itself (e.g., Hansen et al., 1984; Schlesinger and Mitchell, 1987).

A prospective change in the climatological distribution of cloudiness is also of interest for its own sake, however. Changes in cloudiness would be an important component of any climate change scenario, in part because of the important role of clouds in regulating radiation, including ultraviolet radiation, at the Earth's surface.

Unfortunately, the most definite statement that we can make about the projected change in cloudiness is that it is highly uncertain (Cess and Potter, 1987; Cess et al., 1989a, b). In fact, even simulations of the current distribution of cloudiness are less than satisfactory (Randall et al., 1985; Harshvardhan et al., 1989). Current modeling studies of the effects of increased CO₂ concentrations suggest that tropical cloudiness will decrease, while high-latitude cloudiness will increase (Schlesinger and Mitchell, 1987). There is some evidence that overall cloud amount tends to decrease as the Earth warms up (Cess et al., 1989). This is contradicted, however, by observational studies based on the assumption that cloudiness changes accompanying future global warming will parallel those that have occurred in anomalously warm past years (Henderson-Sellers, 1986).

Overall cloud amount is not the issue, however, since it is primarily the integrated liquid water path that determines the effects of the clouds on the radiation field (Stephens, 1978). It has been suggested that the effective liquid water path might increase in a warmer world, even if the overall cloud amount simultaneously decreased (Somerville and Remer, 1984).

It appears, therefore, that large changes in cloud amounts and cloud optical properties could accompany a global warming. These cloudiness changes would produce major perturbations in the global distribution of the surface ultraviolet radiation from the sun. The exact nature of these perturbations is impossible to predict with confidence at this time, but should be investigated in the future.

References

- Cess, R.D. and G.L. Potter (1987). Exploratory studies of cloud radiative forcing with a general circulation model. *Tellus*, **39A**: 460-473.
- Cess, R.D., G.L. Potter, J.P. Blanchet, G. Boer, S.J. Ghan, J.T. Kiehl, X.-Z. Liang, J.F.B. Mitchell, J.-J. Morcrette, D.A. Randall, M.R. Riches, E. Roeckner, U. Schlese, A. Slingo, K.E. Taylor, W.M. Washington, R.T. Wetherald and I. Yagai (1989a). In-

- tercomparison and interpretation of cloud-climate feedback as produced by fourteen atmospheric general circulation models. *Science*, **245**: 513-516.
- Cess, R.D., G.L. Potter, G. Boer, J.P. Blanchet, S.J. Ghan, K.E. Taylor, J.F.B. Mitchell, D.A. Randall, E. Roeckner, U. Schlese, M.E. Schlesinger, W.M. Washington, R.T. Wetherald and I. Yagai (1989b). Intercomparison and interpretation of climate feedback processes in ten atmospheric general circulation models. *J. Geophys. Res.*, submitted.
- Charney, J.G. (1979). *Carbon Dioxide and Climate: A Scientific Assessment*. National Academy Press, Washington, D.C., 33 pp.
- Hansen, J., A. Lacis, D. Rind, G. Russell, P. Stone, I. Fung, R. Ruedy and J. Lerner (1984). Climate sensitivity: Analysis of feedback mechanisms. In: J.E. Hansen and T. Takahashi (eds.), *Climate Process and Climate Sensitivity, Maurice Ewing Series (5)*, American Geophysical Union, pp. 130-163.
- Harshvardhan, D., A. Randall, T.G. Corsetti and D.A. Dazlich (1989). Earth radiation budget and cloudiness simulations with a general circulation model. *J. Atmos. Sci.*, **46**: 1922-1942.
- Henderson-Sellers, A. (1986). Increasing clouds in a warming world. *Climatic Change*, **9**: 267-309.
- Randall, D.A., J.A. Abeles and T.G. Corsetti (1985). Seasonal simulations of the planetary boundary layer and boundary-layer stratocumulus clouds with a general circulation model. *J. Atmos. Sci.*, **42**: 641-676.
- Schlesinger, M.E. and J.F.B. Mitchell (1987). Climate model simulations of the equilibrium climatic response to increased carbon dioxide. *Rev. Geophys.*, **25**: 760-798.
- Smagorinsky, J. (1982). *Carbon Dioxide and Climate: A Second Assessment*. National Academy Press, Washington, D.C., 239 pp.
- Somerville, R.C.J. and L.A. Remer (1984). Cloud optical thickness feedbacks in the CO₂ climate problem. *J. Geophys. Res.*, **89**: 9668-9672.
- Stephens, G.L. (1978). Radiation profiles in extended water clouds II: Parameterization schemes. *J. Atmos. Sci.*, **35**: 2123-2132.

3.4 Changes in Biologically Damaging Ultraviolet (UV) Radiation: Effect of Overhead Ozone and Cloud Amount

Sasha Madronich
Atmospheric Chemistry Division
National Center for Atmospheric Research
P.O. Box 3000
Boulder, Colorado 80303

The ultraviolet radiation field reaching the Earth's surface is a complex function of atmospheric optical parameters such as stratospheric and tropospheric ozone concentrations, aerosol loading, and cloud amount. These optical parameters are expected to change in the future (and may already be changing) as a result of the release of anthropogenic pollutants to the atmosphere. Chlorofluorocarbons (CFCs) emissions are believed to reduce the concentration of stratospheric ozone, while emissions of nitrogen oxides (NO_x) and hydrocarbons may lead to increases in tropospheric ozone. Methane, ozone, and CFCs are also effective infrared absorbers, and may combine with CO_2 to produce an overall increase in surface temperatures (the "greenhouse" effect), with concomitant changes in climatological cloud cover.

In this study, the total (direct and diffuse) surface UV radiation is calculated using a fast and reasonably accurate radiative transfer code which includes detail representations of the temperature dependent ozone absorption, Rayleigh scattering by air molecules, Mie absorption and scattering by aerosol and cloud particles, surface albedo, correction for atmospheric sphericity, and variation in the Earth-Sun distance. Calculations are performed at high spectral resolution over the UV region of biological interest (280–400 nm, with ~ 1 nm increments). Biological dose rates (spectral irradiance convoluted with the action spectra for DNA damage, plant damage, and erythema) are calculated as a function latitude and time of day, and are integrated to give daily, monthly, or yearly doses.

Figure 3.4.1 shows the percentage changes in the daily dose of DNA-damaging radiation which result from changes in ozone column amounts. In panel (a), the ozone column changes were obtained from satellite measurements (drift-corrected TOMS data, from R. Stolarski, private communication). The other panels are based on theoretical predictions for the year 2060, using the University of Wisconsin-NCAR model (WISCAR, from G. Brasseur, private communication) and the Goddard Space Flight Center model (GSFC2, from C. Jackman, private communication). Both are two-dimensional (height, latitude) coupled dynamics-chemistry models, but differ in several respects such as the CO_2 temperature feedback on stratospheric ozone, and the details of tropospheric methane and NO_x chemistry. The cases A1, A2 and D1 represent different scenarios for the emission of those CFCs which were regulated by the Montreal protocol: A1 assumes that the Montreal CFCs remain constant at 1986 levels, with tropospheric methane increasing linearly at the current rate; A2 also assumes the above CFCs emissions, but methane is maintained fixed at current levels; D1 assumes increasing methane, but CFC emissions are reduced by 95%, with the reductions becoming effective over the years 1996–2000. Clearly DNA damage doses are strongly affected by the choice of scenario, and significant inter-model differences are observed. Neither model has a description of the heterogeneous chemistry which is believed to be responsible

for the well-documented Antarctic springtime depletion of ozone (Figure 3.4.1a, which is based on measurements, clearly shows this "ozone hole"). Qualitatively similar results are obtained for erythema and plant damage dose changes.

The results in Figure 3.4.1 assume that the distribution of clouds has remained unchanged over the time period of the calculation. However, it has been noted that clouds may have a large effect on the UV radiation reaching the ground (Frederick and Lubin, *J. Geophys. Res.*, **93**: 3825, 1988). The possibility of a change in the cloud distribution is considered in a separate calculation. Projected changes in average cloud distribution were calculated as a function of latitude for July using two different general circulation models (GCMs), in response to a 2 K increase in sea surface temperature which may nominally occur as a result of climate warming (D. Randall, private communication). For one model (CSU) the cloud cover increased by 1–5% at high latitudes and decreased by 10–15% at low latitudes, while the other model (CCC) predicted 1–30% increases in the polar regions, and as much as 20% reductions at low latitudes. The consequent changes in biological dose rates will be discussed and compared to the changes due to ozone column changes.

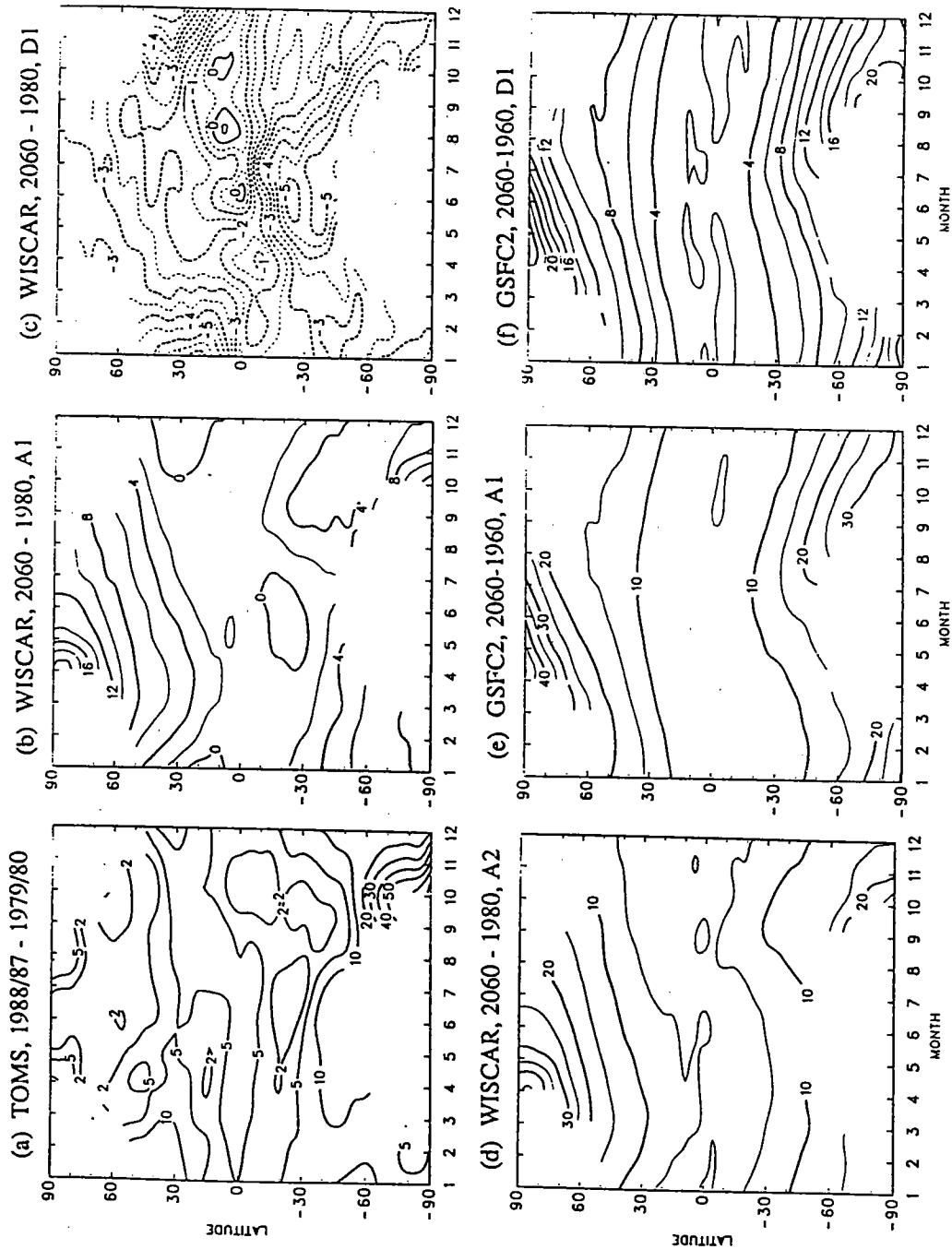

Figure 3.4.1: Percent change in daily dose for DNA damage.

3.5 Remote Sensing of Marine Humus

K.L. Carder¹, S.K. Hawes¹, R.G. Steward¹, K.A. Baker² and R.C. Smith³

¹Marine Science Department
University of Southern Florida
140 Seventh Avenue
St. Petersburg, Florida 33701

²Scripps Institution of Oceanography, A-018
University of California, San Diego
La Jolla, California 92093

³Department of Geography
University of California, Santa Barbara
Santa Barbara, California 93106

Of all the dissolved constituents typically found in seawater, only gelbstoffe or aquatic humus provides a spectral absorption effect large enough for remote quantification from space. Quantification from space of the absorption coefficient of aquatic humus will not be easy. Interpretation of those coefficients in terms of the chemical constituents present may be just as difficult, however. For this reason we have confined our initial studies to regions where the local impact of terrigenous sources of aquatic humus is minimal. In these offshore regions where typical molecular weights were less than 1000, most of the measured absorption was accounted for by absorption due to humic and fulvic acids.

If aquatic humus can eventually be quantified from space, then the mesoscale variability of other dissolved organic constituents can perhaps be inferred as well. To the extent that total dissolved organic matter (DOM) covaries with aquatic humus within the confines of certain oceanic domains, then the variability of total DOM may be inferred. While the sensors to be used from space will be passive instruments that are sensitive to visible and infrared wavelengths, it is expected that absorption coefficients at ultraviolet wavelengths can be extrapolated from the visible. This would rely on the typically logarithmic behavior of spectral absorption curves. We recognize that photolysis may degrade and change the absorption/fluorescence characteristics of aquatic humus, so great care must be taken in making such extrapolations.

The algorithms that have been developed for quantifying ocean chlorophyll *a* plus pheophytin *a* [chl] from space using the Coastal Zone Color Scanner (CZCS) on Nimbus 7 used the spectral ratio of water-leaving radiance values $L_w(433)/L_w(550)$ for [chl] < 1.5 mg/m³. This approach works well for Morel Case 1 waters, where the effects of ocean color constituents covary with [chl]. The absorption effects of chlorophyll *a*, however, cannot be measured separately from effects due to pigment degradation products, pheophytin *a* and aquatic humus. The wavelength range (443–750 nm) for the CZCS was not short enough for exploitation of the range (410–440 nm) where significant differences exist between the spectral absorption curves for phytoplankton and their degradation products.

An algorithm which separately quantifies chlorophyll *a* concentrations and degradation product effects is presented. This algorithm is tested using irradiance reflectance data from California Current waters where $0.05 \leq \text{chl } a \leq 1.5 \text{ mg/m}^3$. It uses spectral bands at 410, 440 and 560 nm, and it reduces the error in estimating chlorophyll *a* for this region from more than 200% to less than $\pm 50\%$.

The algorithm is based upon a model of irradiance reflectance that is directly dependent upon the backscattering coefficient and inversely dependent upon the absorption coefficient for seawater. Instead of tying the absorption coefficients of all absorbing constituents into one term that "covaries" with chlorophyll, they are separated into a phytoplankton term and a degradation product term. The latter consists of absorption due to humic and fulvic acids and phaeophytin/detritus, each of which decreases exponentially with wavelength between 410 nm and 560 nm. The phytoplankton contribution to absorption for any wavelength in this range varies with chlorophyll concentration in a nonlinear manner because of self-shading or the "package effect" and because of changes in the pigment complement.

A curve describing the spectral variation in phytoplankton absorption is presented for each of two oceanic domains: subtropical and temperate. Since phytoplankton tend to be of smaller cell size in warmer waters, and they are typically high-light-adapted (e.g., lower pigment concentration within the cell is required for photosynthesis), the self-shading effect for pigments within the cells is less severe than for temperate and boreal species. Also, within each of these regimes smaller cell sizes are typically found in regions with low nutrients. Thus, the self-shading factor decreases in moving from nutrient-replete waters with large cells to oligotrophic waters with smaller cells. Each of the curves is developed empirically by fitting field data trends, but only the temperate curve has been tested so far in the model used to generate marine humus and chlorophyll concentration algorithms. These tests in California Current waters in late autumn are presented and discussed.

References

- Bricaud, A, A. Morel and L. Prieur (1981). Absorption by dissolved organic matter in the sea (yellow substance) in the UV and visible domains. *Limnol. Oceanogr.*, **26**: 43-53.
- Bricaud, A, A. Morel and L. Prieur (1983). Optical efficiency factors of some phytoplankters. *Limnol. Oceanogr.*, **28**: 816-832.
- Carder, K.L., R.G. Steward, J.H. Paul and G.A. Vargo (1986a). Relationships between chlorophyll and ocean color constituents as they affect remote-sensing reflectance models. *Limnol. Oceanogr.*, **31**: 403-413.
- Carder, K.L., R.G. Steward, G.R. Harvey and P.B. Ortner (1989). Marine humic and fulvic acids: Their effects on remote sensing of ocean chlorophyll. *Limnol. Oceanogr.*, **34**: 68-81.
- Gordon, H.R. and A.Y. Morel (1983). *Remote Assessment of Ocean Color for Interpretation of Satellite Visible Imagery: A Review*. Springer, N.Y.

Harvey, G.R., D.A. Boran, L.A. Chesal and J.M. Tokar (1983). The structure of marine fulvic and humic acids. *Mar. Chem.*, **12**: 119-132.

Hayase, K. and H. Tsubuta (1985). Sedimentary humic acid and fulvic acid as fluorescent organic materials. *Geochim. Cosmochim. Acta*, **49**: 159-163.

Stuermer, R.H. (1975). *The Characterization of Humic Substances in Sea Water*, Ph.D. thesis, Massachusetts Institute of Technology/Woods Hole Oceanographic Institution, 163 pp.

3.6 Calculation of UV-B in Aquatic Systems and Possible Influence on Phytoplankton Communities

¹R.C. Smith and ²K.S. Baker

¹CSL, Center for Remote Sensing and Environmental Optics
University of California, Santa Barbara
Santa Barbara, California 93106

²Institute of Marine Resources, A-018
Scripps Institution of Oceanography
University of California, San Diego
La Jolla, California 92093

Phytoplankton in the upper layers of the sea may be adversely influenced by increased ultraviolet radiation resulting from declines in the thickness of stratospheric ozone (Smith et al., 1980; Smith and Baker, 1980; Worrest, 1986). Evidence supporting this hypothesis includes the fact that wavelengths of potentially damaging ultraviolet radiation can penetrate to ecologically significant depths (Jerlov, 1950; Smith and Tyler, 1976; Smith and Baker, 1981), laboratory findings that many marine organisms are extremely sensitive to this radiation (Nachtwey and Caldwell, 1975; Calkins, 1982; Worrest, 1986; Smith, 1989), and numerous field observations that suggest a role of UV in the photoinhibition of phytoplankton (Harris, 1978; Smith et al., 1980). With a knowledge of ultraviolet radiation at the earth's surface and in the oceans, biochemically weighted dose-rates in aquatic systems can be calculated (Smith and Baker, 1970; Baker and Smith, 1982). Quantitative modeling permits estimation of biological dose rates as a function of ozone concentration, latitude, time and in-water optical and biological properties (Smith and Baker, 1982).

Atmospheric models have been developed in order to characterize the present levels of spectral irradiance reaching the ocean surface and to permit prediction due to changes in the earth's atmosphere (Green et al., 1980; Baker et al., 1980, 1982; Frederick and Lubin, 1988). These models accommodate variation in wavelength, solar zenith angle, ozone thickness, aerosol thickness and surface albedo. Appropriate atmospheric models allow extrapolation of limited surface measurements and can be used as an analytic input to in-water bio-optical models for the assessment of UV penetration to depth in natural waters when propagated through the air-water interface.

The downward spectral irradiance at any depth Z underwater, $E_d(Z, \lambda)$, can be calculated from the spectral irradiance just beneath the ocean surface, $E_d(0^-, \lambda)$, by

$$E_d(Z, \lambda) = E_d(0^-, \lambda) e^{-K_T(\lambda) \cdot Z} \quad (1)$$

where $K_T(\lambda)$ is the total diffuse attenuation coefficient for irradiance. A biologically effective fluence rate is defined

$$E_B(Z, \theta) \left[W \cdot m^{-2} \right]_{\epsilon(\lambda)} = \int E_d(Z, \theta, \lambda) \left[W \cdot m^{-2} \cdot nm^{-1} \right] \cdot \epsilon(\lambda) \cdot d\lambda [nm] \quad (2)$$

where $\epsilon(\lambda)$ is the relative biological efficiency for the biological effect under study. The total daily biologically effective fluence rate can be calculated by integrating $E_B(Z, \theta)$ for all sun angles over the course of a day (Smith and Baker, 1979; Baker and Smith, 1982).

The biological weighting function or relative biological efficiency for damage, $\epsilon(\lambda)$, takes account of the wavelength dependency of biological or chemical action and must be determined for the organisms or populations of interest. It is a critical parameter in the assessment of the potential biological effects of enhanced ultraviolet radiation.

The amplification factor, A , describes that a 1% decrease in ozone may cause an $A\%$ increase in biological effect. This amplification factor may be subdivided into two components: (i) the ratio of the percentage change in biological effective dose, $\Delta\omega/\omega$; i.e., the radiation amplification factor,

$$R = [(\Delta E_{B_e}/E_{B_e})]/[(\Delta\omega/\omega)] \quad (3)$$

and (ii) the ratio of the percentage change in biological effect, $\Delta P/P$, to the percentage change in biologically effective dose, $\Delta E_{B_e}/E_{B_e}$; i.e., the biological amplification factor,

$$B = [(\Delta P/P)]/[(\Delta E_{B_e}/E_{B_e})] \quad (4)$$

so that the total amplification factor is

$$A = R \times B = [(\Delta P/P)]/[(\Delta\omega/\omega)]. \quad (5)$$

Published values of R (Smith and Baker, 1979; Rundel, 1983) range over an order of magnitude (From 0.1 to 4).

Direct determination of effects on natural populations have not been made although estimates range from insignificant to catastrophic. Calculations may be made as described above for estimating possible damage but a key uncertainty remains in knowledge of the correct effective biological weighting function to use in any particular situation. There are serious difficulties in extrapolating laboratory findings to the field (Smith, 1989; Smith and Baker, 1989). Currently there are extreme changes in the ozone layer documented (i.e., in the Antarctic) which emphasizes the need to devise methods to make direct measures of ultraviolet radiation effects on natural communities.

References

- Baker, K.S. and R.C. Smith (1982). Spectral irradiance penetration in natural waters. In: *The Role of Solar Ultraviolet Radiation in Marine Ecosystems*, J. Calkins (ed.), Plenum Press, New York, pp. 233-246.
- Baker, K.S., R.C. Smith and A.E.S. Green (1980). Middle ultraviolet radiation reaching the ocean surface. *Photochem. Photobiol.*, **32**(3): 367-374.
- Baker, K.S., R.C. Smith and A.E.S. Green (1982). Middle ultraviolet irradiance at the ocean surface: measurements and models. In: *The Role of Solar Ultraviolet Radiation in Marine Ecosystems*, J. Calkins (ed.), Plenum Press, New York, pp. 79-91.
- Calkins, J. (ed.) (1982). *The Role of Solar Ultraviolet Radiation in Marine Ecosystems*, Plenum Press, New York.
- Frederick, J.E. and D. Lubin (1988). The budget of biologically active ultraviolet radiation in the earth-atmosphere system. *J. Geophys. Res.*, **93**: 3825-3832.

- Green A.E.S., K.R. Cross, L.-A. Smith (1980). Improved analytic characterization of ultraviolet skylight. *Photochem. Photobiol.*, **31**: 59-65.
- Harris, G.P. (1978). Photosynthesis, productivity and growth: the physiological ecology of phytoplankton. *Arch. Hydrobiol. Beit. Limnol.*, **10**: 1-171.
- Jerlov, N.G. (1950). Ultraviolet radiation in the sea. *Nature*, **166**: 111.
- Nachtwey, D.C. and M.M. Caldwell (eds.) (1975). *Impacts of Climatic Change on the Biosphere, Climatic Impact Assessment Program Monograph 5, Part I, Ultraviolet Radiation Effects*. Department of Transportation, Washington, D.C.: PB 247 724, NTIS, Springfield, Virginia, 674 pp.
- Rundel, R.D. (1983). Action spectra and estimation of biologically effective UV radiation. *Physiol. Plant.*, **58**: 360-366.
- Smith, R.C. (1989). Ozone, middle ultraviolet radiation and the aquatic environment. *Photochem. Photobiol.*, **50**: 459-468.
- Smith, R.C. and K.S. Baker (1979). Penetration of UV-B and biologically effective dose-rates in natural waters. *Photochem. Photobiol.*, **29**: 311-323.
- Smith, R.C. and K.S. Baker (1980). Stratospheric ozone, middle ultraviolet radiation and ¹⁴C measurements of marine productivity. *Science*, **208**(444): 592-593.
- Smith, R.C. and K.S. Baker (1981). Optical properties of the clearest natural waters (200-800 nm). *Applied Optics*, **20**: 177-184.
- Smith, R.C. and K.S. Baker (1982). Spectral irradiance penetration in natural waters. In: *The Role of Solar Ultraviolet Radiation in Marine Ecosystems*, J. Calkins (ed.), Plenum Press, New York, pp. 509-537.
- Smith, R.C. and K.S. Baker (1989). Stratospheric ozone, middle ultraviolet radiation and phytoplankton productivity. *Oceanography*, **2**(2): 4-10.
- Smith, R.C. and J.E. Tyler (1976). *Transmission of Solar Radiation into Natural Waters*, Photobiology Reviews 1, Plenum Press, New York, pp. 117-155.
- Smith, R.C., K.S. Baker, O. Holm-Hansen and R. Olson (1980). Photoinhibition of photosynthesis and middle ultraviolet radiation in natural waters. *Photochem. Photobiol.*, **31**(6): 585-592.
- Worrest, R.C. (1986). The effect of solar UV-B radiation on aquatic systems: an overview. In: *Effects of Changes in Stratospheric Ozone and Global Climate: Overview*, J.G. Titus (ed.), U.S. Environmental Protection Agency and United Nations Environmental Program **1**: 175-191.

4 UV Effects on Atmospheric Chemistry in Condensed Phases

4.1 Influences of Cloud Photochemical Processes on Tropospheric Ozone

P.J. Crutzen and J. Lelieveld
Max-Planck Institute for Chemistry
Division of Atmospheric Chemistry
P.O. Box 3060, D-6500 Mainz
Federal Republic of Germany

Clouds are of great importance in tropospheric chemistry. For instance, upward transport of surface emitted trace gases mostly takes place in clouds. Further, whenever clouds precipitate, they return particulate matter and water-soluble gases to the earth's surface, thus cleaning the troposphere. Clouds also considerably influence the budget of photochemically active radiation, since they scatter ultraviolet solar radiation. Finally, important chemical reactions occur in clouds. Regarding the latter, much emphasis has been given to aqueous phase oxidation processes of SO_2 to sulfuric acid, the major constituent of acid rain (e.g., Calvert et al., 1985). However, studies which treat the over-all role of clouds on the photochemistry of background air are not available, although the basis for such studies was laid in Graedel and Weschler (1981) and Chameides and Davis (1982). In the current study we use a simple chemistry model to investigate the potential effects of clouds on ozone production and destruction rates.

Photochemical processes in an air parcel are drastically altered once the air parcel is cooled and condensation occurs. Although the volume fraction of liquid water in clouds is very small (between 10^{-7} and 10^{-6}), some atmospheric trace gases are so soluble that they are largely present in the droplets (Schwartz, 1986). This implies that these gases are "concentrated" in a relatively small volume, which can enhance reaction rates. The solubility of gases is favored by low temperatures. For instance, the percentage of formaldehyde (CH_2O) in the aqueous phase of clouds with a liquid water content of 0.3 g m^{-3} , increases from 5 to 40 at temperatures of 298 and 268 K, respectively. Temperature is thus one of the controlling factors with respect to the effect of clouds on atmospheric photochemistry.

After dissolution, CH_2O immediately forms $\text{CH}_2(\text{OH})_2$, which reacts rapidly with aqueous phase OH radicals. This reaction is a source of formic acid (HCOOH) (Chameides and Davis, 1983). However, HCOOH is also quite efficiently oxidized by OH in the droplets so that the global average contribution to HCOOH concentrations via this mechanism is limited. The aqueous phase reactions of $\text{CH}_2(\text{OH})_2$ and HCOOH consume OH, but produce HO_2 , so that there is neither loss nor gain of HO_x radicals. H_2O_2 is another important reactant for OH in the droplets. The reaction product, again, is HO_2 . However, since it requires two HO_2 to build one H_2O_2 , this reaction is a net sink of HO_x ($\text{HO}_x = \text{OH} + \text{HO}_2$).

Another source of HO_2 in the droplets, besides aqueous phase breakdown of formaldehyde and H_2O_2 , is scavenging from the gas-phase, which is extremely efficient. A large fraction of the dissolved HO_2 (dependent on the pH) dissociates into H^+ and O_2^- . The superoxide ion can react rapidly with ozone. Despite the relatively low solubility of O_3 , this reaction is the dominant OH source in the aqueous phase. The OH flux, resulting

from this reaction, can be 5 to 50 times larger than scavenging of OH from the gas-phase (at 285 and 268 K, respectively). Hence, OH is recycled through aqueous phase chemistry, and subsequently most of the free radicals formed, react with either $\text{CH}_2(\text{OH})_2$, H_2O_2 or HCOOH again.

An important reaction in the cloudless atmosphere is the reaction of HO_2 with NO , which leads to the formation of NO_2 and subsequently of O_3 (Crutzen, 1979). In clouds, however, this reaction is suppressed. While HO_2 is largely scavenged by the droplets, NO , which dissolves very poorly, is not. Hence, NO and HO_2 become largely separated and ozone production in clouds by this mechanism is strongly reduced. The same argument applies to reaction between CH_3O_2 and NO , which also yields O_3 . Thus, O_3 formation is additionally reduced although CH_3O_2 scavenging is less efficient than of HO_2 . Furthermore, O_3 is destroyed by aqueous phase reaction with O_2^- . This is actually an important O_3 destruction process. Hence, in clouds HO_2 (via O_2^-) always causes net O_3 destruction, whereas in a cloudless atmosphere with sufficient NO_x , HO_2 is the main precursor of O_3 .

During nighttime, chemical activity in the atmosphere is basically low. However, a few reactions are even favored by darkness. Gaseous nitrate radicals (NO_3) are formed by reaction of NO_2 with ozone. During daytime, NO_3 is rapidly photodissociated, whereas during the night NO_3 can react with NO_2 to N_2O_5 . In the presence of cloud droplets, the heterogeneous reaction of N_2O_5 with H_2O may then generate significant amounts of HNO_3 (Platt et al., 1981). This process is an important sink for NO_x , especially in a relatively cold environment, where thermal decomposition of N_2O_5 is slow. Moreover, nights are roughly twice as long as days during the cold season. At the end of a night up to about half of the NO_x may be converted into N_2O_5 . If condensation occurs, the accumulated N_2O_5 almost immediately forms HNO_3 . Since photochemical processes, involving NO_x as catalysts, play a critical role in the formation of O_3 and OH during daytime, a lowering of NO_x concentrations by clouds during the night is likewise of great significance.

The results of our calculations, which focus on the lower 6 km of the troposphere around the equator and at mid-latitudes of both hemispheres, indicate that OH and HO_2 concentrations are reduced by 10–70% due to cloud chemical effects. During summer and at the equator HO_x reductions typically range from 15% neglecting N_2O_5 scavenging, to 30% taking this into account. In NO_x -poor areas H_2O_2 is even more strongly depleted, typically 25–40%. Although the absolute effect of clouds on HO_x chemistry is most important in the summer and in the tropics, the relative effect is strongest during the winter. Firstly this is because aqueous phase processes are favored by more efficient dissolution in the cold season, secondly because the low photochemical activity (compared to summer and tropics) prevents a recovery of the CH_2O , HO_x and H_2O_2 levels between successive cloud events to the levels that are observed during simulations without clouds.

The most interesting outcome of the present study is the strong effect of cloud chemistry on the tropospheric O_3 budget. To a large extent this results from the effective aqueous phase chemical breakdown of O_3 by O_2^- . This, in turn, is due to replenishment of O_2^- by uptake of HO_2 from the gas-phase and recycling reactions with $\text{CH}_2(\text{OH})_2$, HCOOH and H_2O_2 . Net O_3 destruction is further enhanced by a reduction of O_3 formation within clouds (separation of NO from HO_2 and CH_3O_2), as well as during cloud-free periods (reduction of NO_x and HO_x concentrations). We calculate that when there are no clouds, net photochemical O_3 production mainly occurs over the northern hemisphere, whereas

net destruction is more important over the southern hemisphere and at the equator. The balance is a result of transport processes. When clouds are introduced, net O₃ destruction rates during summer in the NO_x-poor areas are enhanced by factors ranging from 1.3 and 2.3 if N₂O₅ scavenging is neglected, and 1.5 to 4 when it is included. Photochemical O₃ formation rates in NO_x-rich areas are reduced by about 30% and 40%, respectively.

References

- Calvert, J.G., A. Lazrus, G.L. Kok, B.G. Heikes, J.G. Walega, J. Lind and C.A. Cantrell (1985). Chemical mechanisms of acid generation in the troposphere. *Nature*, **317**: 27-35.
- Chameides, W.L. and D.D. Davis (1982). The free radical chemistry of cloud droplets and its impact upon the composition of rain. *J. Geophys. Res.*, **87**: 4863-4877.
- Chameides, W.L. and D.D. Davis (1983). Aqueous phase source of formic acid in clouds. *Nature*, **304**: 427-429.
- Crutzen, P.J. (1979). The role of NO and NO₂ in the chemistry of the troposphere and stratosphere. *Ann. Rev. Earth Planet Sci.*, **7**: 443-472.
- Graedel, T.E. and C.J. Weschler (1981). Chemistry within aqueous atmospheric aerosols and raindrops. *Rev. Geophys. Space Phys.*, **19**: 505-538.
- Platt, U., D. Perner, J. Schröder, C. Kessler and A. Toenissen (1981). The diurnal variation of NO₃. *J. Geophys. Res.*, **86**: 11965-11970.
- Schwartz, S.E. (1986). Mass-transport considerations pertinent to aqueous-phase reactions of gases in liquid water clouds. In: W. Jaeschke (ed.), *Chemistry of Multiphase Systems*, NATO ASI series, Vol. G6, Springer Verlag, Berlin, pp. 415-471.

4.2 Laboratory Investigations of Atmospheric Dimethylsulfide Oxidation

P.H. Wine

Molecular Sciences Branch
Georgia Tech Research Institute
Georgia Institute of Technology
Atlantic, Georgia 30332

The atmospheric sulfur cycle has been a subject of intense interest to environmental scientists for many years because of the need to assess the contributions of biogenic and anthropogenic sulfur to such problems as acid rain, visibility reduction, and climate modification (or regulation (Charlson et al., 1987; Schwartz, 1988)). In heavily industrialized regions such as the eastern United States, anthropogenic sulfur emissions exceed natural emissions by about an order of magnitude (Galloway and Whelpdale, 1980; Möller, 1984). On a global scale, however, biogenic sulfur emissions are thought to approximately equal those from anthropogenic sources (Schwartz, 1988; Cullis and Hirschler, 1980). An understanding of the biogenic sulfur cycle is thus required in order to establish a baseline against which anthropogenic perturbations can be compared.

Marine dimethylsulfide (DMS) emissions are thought to account for about half of the global flux of biogenic sulfur into the atmosphere (Andreae, 1985; Bates et al., 1987). Hence, DMS oxidation is a chemical process of central importance in the biogenic sulfur cycle. The atmospheric oxidation of DMS occurs predominantly in the gas phase and is thought to be initiated primarily by reaction with the OH radical (Hynes et al. 1986). Other gas phase free radicals which may play an important role as initiators of DMS oxidation include NO_3 (Atkinson et al., 1984) and IO (Barnes et al., 1989). Recent studies of OH, NO_3 , and IO reactions with DMS which have been carried out in our laboratory are discussed below.

The OH + DMS Reaction

A paper describing our studies of this key reaction was published about three years ago (Hynes et al., 1986). In the presence of O_2 , we found that reaction proceeds via a four-step mechanism involving hydrogen abstraction, addition to the sulfur atom, and reaction of the adduct with O_2 in competition with adduct dissociation back to reactants. The kinetics of individual steps in the mechanism were analyzed. In one atmosphere of air, the "effective" rate constant for the OH + DMS reaction increases markedly with decreasing temperature; in units of $10^{-12} \text{ cm}^3 \text{ molecule}^{-1} \text{ s}^{-1}$, $k = 5.2, 7.4, 12.5, \text{ and } 15.8$ at $T = 310, 290, 270, \text{ and } 250 \text{ K}$. The branching ratio for hydrogen abstraction is 0.87 at 310 K but only 0.24 at 250 K. Plausible reaction mechanisms can be proposed which lead to a number of stable end products including SO_2 , COS, $(\text{CH}_3)_2\text{SO}$ (dimethylsulfoxide, DMSO), CH_3SO_2 (dimethylsulfone, DMSO_2), and $\text{CH}_3\text{SO}_3\text{H}$ (methanesulfonic acid, MSA). A recent laboratory study, conducted under the low NO_x conditions typical of remote marine regions, observed only SO_2 and DMSO_2 as end products (Barnes et al., 1988). On the other hand, field data suggest substantial yields of MSA (Saltzman et al., 1983, 1986; Berresheim, 1987).

The NO₃ + DMS Reaction

This reaction, which occurs primarily at night, can be an important DMS oxidation pathway in continental and coastal areas where NO_x levels are relatively high. The best published kinetics study is the work of Dlugokencky and Howard (1988); these authors observed a negative activation energy of ~1 kcal/mole with $k(298\text{ K}) = 1.1 \times 10^{-12} \text{ cm}^3 \text{ molecule}^{-1} \text{ s}^{-1}$. The observed negative activation energy and rapid reaction rate strongly suggest that the initial step is addition to the sulfur atom. The NO₂ yield is known to be no more than a few percent (Dlugokencky and Howard, 1988; Tyndall et al., to be published), suggesting that adduct decomposition to DMSO + NO₂ is not an important reaction channel. Tyndall et al. (to be published) have observed SO₂ and methylsulfinylperoxynitrate (CH₃S(O)OONO₂) as end products with approximately equal yields. We have recently studied the kinetics of NO₃ reactions with the organic sulfides DMS, DMS-d₆, and DES (diethylsulfide) at T = 298 K. We find large differences in reactivity with $k(\text{DES}) \sim 4 k(\text{DMS}) \sim 4k(\text{DMS-d}_6)$. Our results suggest that, even though NO₃ does not react with DMS via a direct hydrogen abstraction pathway, the overall reaction mechanism must involve breaking of a C-H bond.

The IO + DMS Reaction

Two published studies of the kinetics of this reaction suggest that the IO + DMS reaction is very fast ($k = (1.5 - 3) \times 10^{-11} \text{ cm}^3 \text{ molecule}^{-1} \text{ s}^{-1}$) (Barnes et al., 1987; Martin et al., 1987), leading to speculation that IO may be an important sink for marine DMS (Barnes et al., 1989). However, the concentration of IO radicals in marine air is unknown and DMSO, a reported product of the IO + DMS reaction (Barnes et al., 1987; Martin et al., 1987) does not appear to be present in the atmosphere at levels sufficient to support the removal of DMS by a process which generates DMSO (Harvey and Lang, 1986; Andreae, personal communication). Furthermore, in the recent IUPAC evaluation of kinetic and photochemical data for atmospheric chemistry, it is pointed out that neither published study of IO + DMS kinetics directly observed IO radicals, so the mechanism for observed DMS loss may have been misinterpreted (Atkinson et al., 1989). The IUPAC panel makes no recommendation of an IO + DMS rate constant (Atkinson et al., 1989). We have studied the kinetics of the IO + DMS reaction by directly observing the temporal behavior of IO radicals following laser flash photolysis of NO₂/I₂/DMS/N₂ mixtures. We find IO to be approximately three orders of magnitude less reactive toward DMS than previously reported (Barnes et al., 1987; Martin et al., 1987). Our results suggest that the proposed coupling of IO_x and SO_x chemistry in the marine boundary layer (via the IO + DMS reaction) (Barnes et al., 1989) is insignificant.

Acknowledgements

The work reported in this abstract was supported by the National Science Foundation. Collaborators were A.J. Hynes, E.P. Daykin, and D.H. Semmes.

References

- Andreae, M.O. (1985). *The Biogeochemical Cycling of Sulfur and Nitrogen in the Remote Atmosphere*, Reidel, Dordrecht, pp. 5-25.
- Atkinson, R., J.N. Pitts, Jr. and S.M. Aschmann (1984). *J. Phys. Chem.*, **88**: 1584.
- Atkinson, R., D.L. Baulch, R.A. Cox, R.F. Hampson, Jr., J.A. Kerr and J. Troe (1989). *J. Phys. Chem. Ref. Data*, **18**: 881.
- Barnes, I., V. Bastian and K.H. Becker (1988). *Int. J. Chem. Kinet.*, **20**: 415.
- Barnes, I., K.H. Becker, P. Carlier and G. Mouvier (1987). *Int. J. Chem. Kinet.*, **19**: 489.
- Barnes, I., K.H. Becker, D. Martin, P. Carlier, G. Mouvier, J.L. Jourdain, G. Laverdet and G. LeBras (1989). *Biogenic Sulfur in the Environment*, ACS Symposium Series No. 393, pp. 464-475 + references therein.
- Bates, T.S., J.D. Cline, R.H. Gammon and S.R. Kelly-Hansen (1987). *J. Geophys. Res.*, **92**: 2930.
- Berresheim, J. (1987). *J. Geophys. Res.*, **92**: 13245.
- Charlson, R.J., J.E. Lovelock, M.O. Andreae and S.G. Warren (1987). *Nature*, **326**: 655.
- Cullis, D.F. and H.M. Hirschler (1980). *Atmos. Environ.*, **14**: 1263.
- Dlugokencky, E. and C.J. Howard (1988). *J. Phys. Chem.*, **92**: 1188.
- Galloway, J.N. and D.M. Whelpdale (1980). *Atmos. Environ.*, **14**: 409.
- Harvey, G.R. and R.F. Lang (1986). *Geophys. Res. Lett.*, **13**: 49.
- Hynes, A.J., P.H. Wine and D.H. Semmes (1986). *J. Phys. Chem.*, **90**: 4148.
- Martin, D., J.L. Jourdain, G. Laverdet and G. Lebras (1987). *Int. J. Chem. Kinet.*, **19**: 503.
- Möller, D. (1984). *Atmos. Environ.*, **18**: 19 and 29.
- Saltzman, E.S., D.L. Savoie, R.G. Zika and J.M. Prospero (1983). *J. Geophys. Res.*, **88**: 10897.
- Saltzman, E.S., D.L. Savoie, J.M. Prospero and R.G. Zika (1986). *J. Atmos. Chem.*, **4**: 227.
- Schwartz, S.E. (1988). *Nature*, **336**: 441.
- Tyndall, G.S., J.P. Burrows and G.K. Moortgat (to be published).

4.3 Laboratory Studies Related to the Aqueous Chemistry of Clouds

P. Warneck, H.-J Benkelberg and U. Deister
 Max-Planck Institute for Chemistry
 P.O. Box 3060, D-6500 Mainz
 Federal Republic of Germany

Radical scavenging techniques (with product analysis) were applied to study the generation of radicals by photolytic processes and reactions of such radicals in aqueous solution. A variety of photodecomposition processes, involving mostly inorganic anions, have been explored as radical sources and the following were found suitable for our purposes: NO_3^- as a source of OH radicals, SO_3^- as a source of SO_3^- , and $\text{S}_2\text{O}_8^{2-}$ as a source of SO_4^- . A suitable source of oxygen atoms is still to be found. In the present paper, we discuss laboratory data on the photo-oxidation of sulfite, on the reaction of OH radicals with hydroxymethanesulfonate, and on the quantum yield of OH formation from the photodecomposition of iron(III) hydroxo complexes.

The first process is a well-known chain reaction, and by applying the scavenging technique, we were able to extract some information on the radicals involved and their reactions (Deister and Warneck, in press). The photolysis of sulfite (pH = 8–9) was studied in the absence of oxygen, in its presence, and in the additional presence of scavengers. In the absence of oxygen the major products were dithionate and sulfate with a molar ratio of 0.5. From the total product yield, the primary quantum yield for the formation of SO_3^- radicals was determined as 0.85. In the presence of oxygen, dithionate was not observed and the formation of sulfate was extremely rapid. While these data confirmed the existence of a chain reaction, they did not provide information on the mechanism. The addition of benzene as a radical scavenger led to the formation of phenol. The further addition of tert-butanol, which reacts rapidly with OH but slowly with SO_4^- , did not cause a reduction in the yield of phenol. This indicated that the sulfate radical SO_4^- , and not OH, is one of the main chain carriers. When benzene was replaced by either 2-propanol or ethanol, the products were acetone and acetaldehyde, respectively, in addition to sulfate. From the product ratios as a function of the $[\text{SO}_3^-]/[\text{alcohol}]$ concentration ratio the rate constant for the reaction:

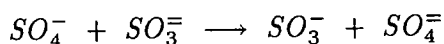

was derived by competitive kinetics: $k = 5.5 \times 10^8 \text{M}^{-1}\text{s}^{-1}$. The data also provide information on the branching ratio for the two channels of the reaction:

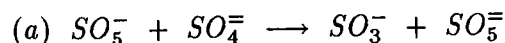

and

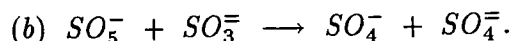

The value obtained was $k_a/k_b = 0.41$. The applicability of these data to cloud chemistry is still marginal, because of the alkaline solutions used in this study, whereas the pH of cloud water generally is less than pH = 6.

Hydroxymethanesulfonate is the addition product between formaldehyde and sulfite (or bisulfite) in aqueous solution. The compound is believed to be an important S(IV) species in

clouds and fogs. Current computer models do not yet include HMS, but they indicate that reactions with OH radicals are important not only in the gas phase but also in the aqueous phase. We have attempted to determine the rate coefficient for the reaction $\text{OH} + \text{HMS}$ by competition kinetics relative to the rate constant for the reaction of OH with benzene ($\text{pH} = 5$). The formation of phenol served as an indicator for the extent of the last reaction. Photolysis of the nitrate ion was used as a source of OH, and for comparison a variety of other OH reactions were studied as well. In all these cases, the rate coefficients derived were in good agreement with literature data. The data for HMS seemingly indicated a fairly slow reaction, $K \sim 5 \times 10^7 \text{M}^{-1}\text{s}^{-1}$. If the reaction were really that slow, the rate coefficient would have to be further corrected for the reactions of OH with HSO_3^- and with formaldehyde, both of which are fast. These compounds are present in small concentrations in equilibrium with HMS. However, we have also measured the production of sulfate and found it to exceed greatly the loss of OH as calculated from the decrease in the yield of phenol. This result indicates the occurrence of a chain reaction, and it invalidates the procedure used by us in the determination of the rate coefficient. In fact, on the basis of a reaction scheme, which incorporates reactions of OH and SO_4^- radicals as the main chain carriers, we estimate a rate coefficient of about $2.5 \times 10^9 \text{M}^{-1}\text{s}^{-1}$. Martin et al (1989) have recently studied the same reactions in competition with pinacol by means of Fenton's reagent as a source of OH, and they reported a rate coefficient of $1.2 \times 10^9 \text{M}^{-1}\text{s}^{-1}$. Although both values agree in magnitude, it is clear that further work is required on this system.

In current cloud models, the major route for the formation of OH radicals in the aqueous phase is the incorporation of HO_2 radicals from the gas phase, followed by dissociation to give O_2^- ions and their reaction with dissolved ozone. The O_3^- anion thus formed then reacts with protons to produce OH and O_2 . The primary production of OH by photodissociation of the NO_3^- ion or of H_2O_2 is fairly inefficient at solar wavelengths available in the troposphere. However, Weschler et al. (1986) have pointed out that the photodecomposition of iron(III) when complexed with OH^- may be an important source of OH in clouds provided the quantum yields are favorable. We have measured these quantum yields in aqueous solutions of iron(III) perchlorate at $\text{pH} = 3$. The species that must be taken into account in such solutions are Fe^{3+} , FeOH^{2+} , $\text{Fe}(\text{OH})_2^+$ and $\text{Fe}_2(\text{OH})_2^{4+}$. From the known equilibrium constants we calculate with $\text{Fe}(\text{III}) = 2 \times 10^{-4} \text{M}$, that at $\text{pH} = 3$ the distribution is 10% Fe^{3+} , 68% FeOH^{2+} , 21% $\text{Fe}(\text{OH})_2^+$ and 0.6% $\text{Fe}_2(\text{OH})_2^{4+}$. The mixed quantum yields for FeOH^{2+} and $\text{Fe}(\text{OH})_2^+$, which contribute to the formation of OH, were determined as a function of wavelength with the help of a monochromator in the spectral region 295–370 nm. The scavenger in this case was 2-propanol, and the product measured was acetone, which is produced with at least 87% yield. The OH quantum yield was found to maximize at wavelengths near 300 nm with a value of 0.18, but it decreased with an increasing wavelength toward about 1/3 of that value at 360 nm. The effect is in accord with the notion that the ejection of OH from the solvent cage into solution requires kinetic energy, which must be provided by excitation of the ion in excess of the dissociation energy threshold. Since the release of OH into solution is in competition with in-cavity geminate recombination of OH with Fe^{2+} , an increase of the excitation energy also increases the probability for the escape of OH from the solvent cage. Our data are in reasonable agreement with OH quantum yields at 313 and 360 nm recently reported by Faust and Hoigné (in press) for $\text{pH} = 4$. We have used our data to calculate a photodissociation coefficient for

clear sky summer atmospheric conditions at 45° northern latitude. Depending on the choice of absorption coefficients, either from our data at pH = 3 or from the data of Faust and Hoigné (in press) at pH = 4, we found $j = 0.67 \times 10^{-3}$ or $1.09 \times 10^{-3} \text{s}^{-1}$. These values are high enough to suggest for typical iron(III) concentrations in continental clouds of $1 \mu\text{M}$, that OH production rates from this process can very well compete with other routes of OH formation in the aqueous phase of clouds.

References

- Deister, U. and P. Warneck (in press). On the photo-oxidation of SO_3^- in aqueous solution. *J. Phys. Chem.*
- Faust, C.B. and J. Hoigné (in press). Photolysis of Fe(III)-hydroxy complexes as sources of OH radicals in clouds, fog and rain. *Atmos. Environ.*
- Martin, L.R., M.P. Easton, J.W. Foster and M.W. Hill (1989). Oxidation of hydroxymethanesulfonic acid by Fenton's reagent. *Atmos. Environ.*, **23**: 563-568.
- Weschler, C.J., M.L. Mandich and T.E. Graedel (1986). Speciation, photosensitivity, and reactions of transition metal ions in atmospheric droplets. *J. Geophys. Res.*, **9**: 5189-5204.

4.4 Aqueous-Phase Photochemical Sources of Oxidants in Clouds

Bruce C. Faust and John M. Allen
School of Forestry and Environmental Studies
Environmental Chemistry Laboratory
Duke University
Durham, North Carolina 27706

The concerns about acid rain and the atmospheric carbon cycle have increased interest in the sources of oxidants that oxidize compounds in atmospheric water drops (Chameides, 1984; Chameides and Davis, 1982; Cho and Carmichael, 1986; Faust and Hoigné, in press; Graedel and Weschler, 1981, 1985; Graedel et al., 1986; Haag et al., 1984; Howard and Scaiano, 1984; Jacob, 1986; Schwartz, 1983). Several investigations have suggested that aqueous-phase photochemical reactions are significant sources of hydroxyl radical in atmospheric water drops (Chameides, 1984; Chameides and Davis, 1982; Cho and Carmichael, 1986; Faust and Hoigné, in press; Graedel and Weschler, 1981, 1985; Graedel et al., 1986; Jacob, 1986; Schwartz, 1983). Analogous sources of other oxidants have not been identified. We have conducted experiments to identify some of the photochemical oxidants that are formed during the sunlight photolysis of cloud waters, and report that singlet molecular oxygen, a heretofore unreported cloud-water oxidant, and another oxidant (probably organic peroxy radicals) are formed from photochemical reactions of compounds present in cloud waters. These oxidants are present at concentrations much larger than predicted by atmospheric models. They destroy furfuryl alcohol and 2,4,6-trimethylphenol, with half-lives of 0.5–10 hours in sunlit cloudwaters, and could affect the concentrations of many other compounds in cloud and fog drops.

Cloud-water samples, collected by colleagues in New York, Virginia, Washington, and North Carolina, all exhibited photo-oxidant formation in sunlight. Singlet molecular oxygen ($^1\text{O}_2^*$) was chemically trapped by furfuryl alcohol (FFA), while organic peroxy radicals (RO_2) were chemically trapped by 2,4,6-trimethylphenol (TMP). Furfuryl alcohol and 2,4,6-trimethylphenol were chosen because of their high reactivities toward $^1\text{O}_2^*$ (Haag and Hoigné, 1984) and RO_2 (Howard and Scaiano, 1984), respectively. Neither FFA nor TMP reacted appreciably in dark controls or when exposed to sunlight in distilled water.

To demonstrate the involvement of $^1\text{O}_2^*$ in the oxidation of FFA, the effects of deuterium oxide (D_2O) were studied. The photo-oxidations of FFA were more rapid in air-saturated 3:1 mixtures of deuterium oxide-cloud water than in 3:1 mixtures of distilled water-cloud water, where the pH was adjusted to that of the pure cloud water using sulfuric acid. The increased rate of FFA oxidation is attributed to the increased lifetime, and therefore increased steady-state concentration, of $^1\text{O}_2^*$ in the presence of deuterium oxide (Rodgers and Snowden, 1982). Kinetic analyses of the effect of deuterium oxide on photo-oxidations of FFA in cloud waters indicate that the fraction of FFA oxidation that is attributable to $^1\text{O}_2^*$ ranges from 20–40% for cloud waters from different locations. The remaining fraction of FFA oxidation is probably due to RO_2 radicals.

Additional support for the photochemical formation of RO_2 is given by the observation that TMP, a classic trap for RO_2 radicals (Howard and Scaiano, 1984), is rapidly oxidized in sunlit cloud waters (half-lives of 1–10 hours). Rates of TMP photo-oxidation, unlike those

of FFA, were not affected by the presence of deuterium oxide, demonstrating that $^1\text{O}_2^*$ was not involved in the oxidation of TMP.

Hydroxyl radical ($\cdot\text{OH}$) is not responsible for the photo-oxidations of FFA and TMP. This conclusion is based on the observations that cloud-water photo-oxidations of FFA and TMP were 4–10 and 6–9 times faster, respectively, than photo-oxidations of phenol, despite the similar diffusion-controlled reactivities of phenol, FFA, and alkylphenols with $\cdot\text{OH}$ radical.

Due to a lack of information, models of atmospheric water drop chemistry do not include direct aqueous-phase photochemical sources of $^1\text{O}_2^*$, RO_2 , or HO_2 . These models, consequently, significantly underestimate the concentrations of some oxidants in cloud drops. Aqueous-phase photochemical reactions are the primary source of $^1\text{O}_2^*$ in atmospheric water drops. An upper bound for cloud-drop $^1\text{O}_2^*$ of 5×10^{-15} M is calculated based solely on the equilibrium partitioning of gas-phase $^1\text{O}_2^*$ (1×10^8 molecules/cm³). This is only 0.7–10% of our measured $^1\text{O}_2^*$ concentrations in sunlit cloudwaters. Model predictions of cloud-drop RO_2 concentrations range from 2×10^{-12} to 2×10^{-10} M, which is only 0.01–20% of our measured RO_2 concentrations in sunlit cloudwaters.

Reactions of $^1\text{O}_2^*$, RO_2 , and HO_2 with organic compounds often form peroxide products, and could, therefore, be important sources of peroxides found in atmospheric waters (Hellpointner and Gäb, 1989).

The relative contributions of aqueous-phase versus gas-phase oxidations to the overall tropospheric oxidation rate of a chemical is dependent upon the partitioning of the compound between the aqueous and gas phases. The equilibrium partitioning is calculated using Henry's Law. However, the measurements of Glotfelty et al. (1987) on fog water and the surrounding interstitial air have shown that many pesticides and pesticide oxidation products are preferentially enriched in the aqueous phase, at levels that are 1–3000 times larger than those predicted by Henry's Law using the measured gas phase concentrations. It is estimated that a substantial mass fraction of numerous other types of organic compounds (e.g., cresols, aldehydes, trimethylamine, aniline, polycyclic aromatic hydrocarbons, terpenes, and terpenoids) that react with $^1\text{O}_2^*$ or RO_2 are present in water drops during cloud and fog events. Thus, oxidations of organic compounds in cloud drops by photochemically-generated $^1\text{O}_2^*$ and RO_2 could be a significant sink for some organic compounds in the atmosphere. Photochemical processes, similar to those described here for clouds, probably are important sources of oxidants in fogs, rain, dew and hydrated aerosols.

References

- Chameides, W.L. (1984). *J. Geophys. Res.*, **89**: 4739–4755.
- Chameides, W.L. and D.D. Davis (1982). The free radical chemistry of cloud droplets and its impact upon the composition of rain. *J. Geophys. Res.*, **87**: 4863–4877.
- Cho, S.-Y. and G.R. Carmichael (1986). *Atmos. Environ.*, **20**: 1959–1968.
- Faust, C.B. and J. Hoigné (in press). Photolysis of Fe(III)-hydroxy complexes as sources of OH radicals in clouds, fog and rain. *Atmos. Environ.*.
- Glotfelty, D.E., J.N. Seiber and L.A. Liljedahl (1987). *Nature*, **325**: 602–605.

- Graedel, T.E. and C.J. Weschler (1981). Chemistry within aqueous atmospheric aerosols and raindrops. *Rev. Geophys. Space Phys.*, **19**: 505-539.
- Graedel, T.E., Weschler, C.J. and M.L. Mandich (1985). *Nature*, **317**: 240-242.
- Graedel, T.E., M.L. Mandich and C.J. Weschler (1986). *J. Geophys. Res.*, **91**: 5205-5221.
- Haag, W.R., J. Hoigné, E. Gassman and A.M. Braun (1984). *Chemosphere*, **13**: 631-640.
- Hellpointner, E. and S. Gäb (1989). *Nature*, **337**: 631-634.
- Howard, J.A. and J.C. Scaiano (eds.) (1984). *Kinetic Rate Constants of Radical Reactions in Solution: Part d, Oxyl-, Peroxyl-, and Related Radicals*, Landolt Börnstein New Series, Series II/13d, Springer-Verlag, Berlin-Heidelberg.
- Jacob, D.J. (1986). *J. Geophys. Res.*, **91**: 9807-9826.
- Rodgers, M.A.J. and P.T. Snowden (1982). *J. Amer. Chem. Soc.*, **104**: 5541-5543.
- Schwartz, S.E. (ed.) (1983). *Trace Atmospheric Constituents: Properties, Transformations, and Fates*, Wiley, New York.

4.5 Heterogeneous Photocatalysis on the Surface of Metal Oxides

Michael R. Hoffmann
W.M. Keck Laboratories
California Institute of Technology
Pasadena, California 92215

The term photocatalysis may be misleading. Moore and Pearson (1981) contend that "catalysis by light" is an improper phrase; they argue that when the rate of a reaction is accelerated by a means other than by a chemical species that it should not be classified as catalytic. However, it is clear that some reactions, which are thermodynamically favorable (i.e., $\Delta G_{rxn}^0 < 0$), can be assisted by the interaction with light in the UV-VIS range. These reactions are sometimes called photo-assisted reactions. They can occur either homogeneously or heterogeneously.

Photo-assisted reactions can be further categorized as being either photosynthetic (i.e., $\Delta G_{rxn}^0 > 0$) or photocatalytic (i.e., $\Delta G_{rxn}^0 < 0$). An example of a photosynthetic reaction would be the photo-assisted elimination/rearrangement reactions of aldehydes (March, 1977):

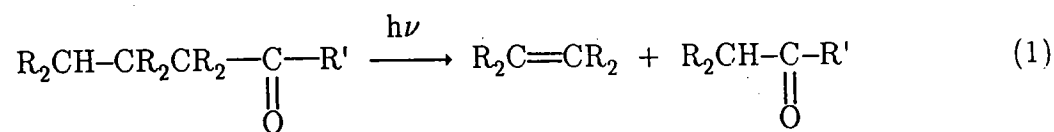

Another example of a photo-assisted reaction is provided by the irradiation of *o*-nitrobenzaldehydes to give the corresponding benzoic acids.

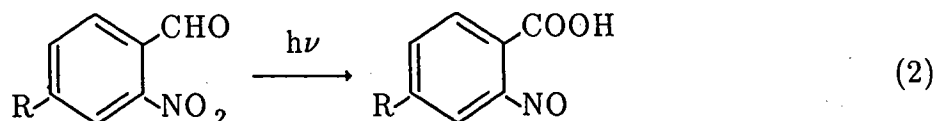

In the category of photocatalytic reactions (a malaprop according to Moore and Pearson (1981)) we could include examples of a variety of two-electron oxidations and reductions that are very slow in the absence of catalytic influences. A primary example for this situation is the oxidation of S(IV) $\{\text{SO}_2 \cdot \text{H}_2\text{O}, \text{HSO}_3^-, \text{SO}_3^{2-}\}$ by oxygen to S(VI) $\{\text{SO}_4^{2-}\}$, which has the following stoichiometry:



In the absence of any catalytic influence, this reaction is exceedingly slow (Hoffmann and Boyce, 1983; Hoffmann and Jacob, 1984; Boyce et al., 1983). However, in the presence of

light with $\lambda \leq 285$ nm this reaction is accelerated many fold; thus in a liberal definition of catalysis, wherein we consider the wave-particle duality of light and matter (Hawking, 1988), this reaction is catalyzed nominally by light. The autoxidation of S(IV) is sensitive also to trace metal catalysis, enzymatic catalysis {*sulfite oxidase*} and to heterogeneous photocatalysis (Faust et al., 1989).

Semiconductors such as TiO_2 , Fe_2O_3 , CdS and ZnS are shown to be photochemical catalysts for a wide variety of reactions. When a photon with an energy of $h\nu$ matches or exceeds the bandgap-energy, E_g , of the semiconductor, an electron \bar{e} , is promoted from the valence band, VB, into the conduction band, CB, leaving a hole, h^+ , behind. Electrons and holes can then recombine (and dissipate the input energy as heat) or migrate to the surface and be trapped in surface states of the material. Surface-site trapping of electrons and holes appears to be an important process for redox reactions on semiconductor surfaces.

The redox potentials of both, \bar{e} and h^+ , are determined by the relative position of the conduction and valence band, respectively. In general semiconductor metal oxides exhibit "Nernstian" behavior which results in a shift of the surface redox potential by 59 mV in the negative direction with a $\Delta\text{pH} = +1$. Thus, electrons are better reductants in the basic pH range while holes have a higher oxidation potential in the acidic pH range. With the right choice of semiconductor and pH, the redox potential of the \bar{e}_{cb} can be varied from +0.5 to -1.5 V and that of the h_{vb}^+ from +1.0 to more than +3.5 V. If $\Delta G^0 < 0$ for the overall reaction, then photo-assisted reactions can be classified as photocatalytic; whereas if $\Delta G^0 > 0$, then photo-assisted reactions can be classified as photosynthetic.

The catalytic autoxidation of SO_2 in deliquescent haze aerosol, clouds, fogs and hydrometeors appears to be a viable pathway for the rapid formation of sulfuric acid in humid atmospheres. Jacob and Hoffmann (1983) have shown that Fe(III) and Mn(II) are the most effective catalysts at ambient concentrations for the autoxidation of S(IV) to S(VI) in cloud- and fogwater. Ferric oxides and oxyhydroxides ($\alpha - \text{Fe}_2\text{O}_3$, Fe_3O_4 , $\alpha - \text{FeOOH}$, and $\gamma - \text{FeOOH}$) have been identified as components of airborne particles; iron-containing particles such as these are likely to serve as cloud and fog condensation nuclei and to be suspended and/or dissolved in the liquid droplet that results.

$\alpha - \text{Fe}_2\text{O}_3$ (hematite) can function as either a photosensitizer or as photocatalyst. Absorption of a photon with an energy equal to or greater than the bandgap energy, E_g , (2.2 eV or 520 nm) results in the transient formation of an electron/hole pair.

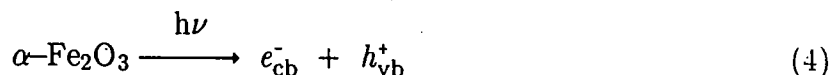

In the absence of suitable electron and hole scavengers adsorbed to the surface of a semiconductor particle, recombination occurs within 1 ns. However, when appropriate scavengers are present, the valence band holes, h_{vb}^+ ($E_H^7 = 2.3$ V {*ox. pot.*}) function as powerful oxidants while the conduction band electrons, e_{cb}^- , ($E_H^7 = 0.0$ V {*red. pot.*}) function as moderately powerful reductants.

The kinetics and mechanism of the photo-assisted oxidation of S(IV) in the presence of suspensions of $\alpha - \text{Fe}_2\text{O}_3$ have been studied over the pH range of 2 to 10.5 (Faust et al.,

1989). Similar kinetic behavior toward S(IV) was observed for colloidal suspensions of TiO₂. Quantum yields, ϕ , ranged from 0.08 to 0.3 with a maximum yield found at pH 5.7. Upon band-gap illumination conduction-band electrons and valence-band holes are separated; the trapped electrons, e_{tr}^- , are transferred either to surface bound dioxygen or to Fe(III) sites on or near the surface, while the trapped holes, h_{tr}^+ , accept electrons from adsorbed S(IV) to produce S(V). The formation of S(V) radicals indicates that the reaction proceeds via successive one-electron transfers. The relatively high quantum yields can be attributed in part to the desorption of SO₃⁻ from the α -Fe₂O₃ surface and subsequent initiation of a homogeneous free radical chain reaction.

The photoassisted heterogeneous oxidation of S(IV) appears to proceed via rapid formation of Fe(III)-S(IV) surface complexes formed by ligand exchange with the surface hydroxyl groups. For example, two possible surface complexes are as follows:

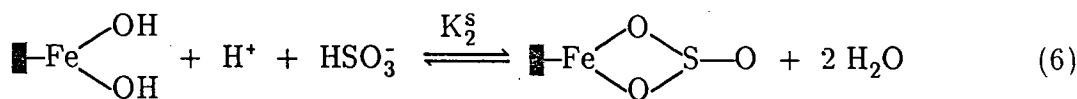

In the first case, a mononuclear monodentate surface complex is formed, while in the second case a mononuclear bidentate complexed is formed. In the pH range of 1 to 3, the overall rate of reaction is limited by $[\blacksquare\text{-FeOSO}_2^-]$ or $[\blacksquare\text{-FeO}_2\text{SO}]$ up to the saturation limit imposed by the total number of available surface sites (~ 10 sites/nm²). Enhanced reactivity in the pH range of 5 to 7 can be attributed either to the more favorable surface complexation of SO₃²⁻ (e.g., $\blacksquare\text{-Fe} \begin{array}{l} \text{OH} \\ \diagdown \\ \text{OH} \end{array} + \text{SO}_3^{2-} \rightleftharpoons \blacksquare\text{-Fe} \begin{array}{l} \text{OH} \\ \diagdown \\ \text{OSO}_2^- \end{array} + \text{H}_2\text{O}$) or to the increased contribution of reaction pathways that occur independently of the surface coordination sites. For example, SO₃⁻ generated at a surface site may diffuse into the bulk phase and initiate a free radical chain reaction involving O₂. Likewise, Fe(II) can be oxidized readily above pH 5 to give Fe(III) which can in turn catalyze the autoxidation of S(IV) in the aqueous phase.

Light absorption with photon energies exceeding the bandgap energy of α -Fe₂O₃ leads to the formation of electron-hole pairs followed by the one-electron oxidation of adsorbed sulfite yielding the SO₃⁻ radical anion.

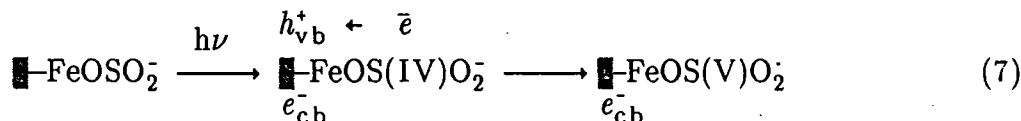

The formation of sulfite radical anion (i.e., SO_3^-) as an intermediate is indicated by the fact that $\text{S}_2\text{O}_6^{2-}$ ($2 \text{SO}_3^- \rightarrow \text{S}_2\text{O}_6^{2-}$) is one of the end products when the illuminations are carried out under N_2 .

In the absence of a suitable electron acceptor bound to the surface the $\blacksquare\text{-Fe(III)OH}$ surface site (e.g., $\blacksquare\text{-Fe(III)O=O}$), the $\blacksquare\text{-Fe(III)OH} + e_{cb}^-$ reaction produces $\blacksquare\text{-Fe(II)OH}$, which leads to the subsequent release of Fe_{aq}^{2+} to the solution phase and the progressive dissolution of the particle as shown below:

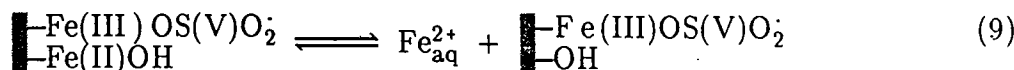
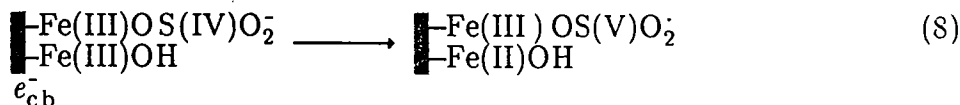

Even though the trapping of the conduction band electron should be rapid, the subsequent dissolution step may be slow.

The photocatalytic autoxidation of S(IV) on TiO_2 with particle diameters of ≥ 30 nm was found to have quantum yields, ϕ , that ranged from 0.5 to 300 depending on the reaction conditions (Hong et al., 1987). Quantum yields in excess of one provide strong evidence for a free radical chain mechanism. These quantum yields are relatively high compared to other photoassisted semiconductor-catalyzed redox reactions, thus some contribution to the overall rate may in fact be due to a homogeneous free radical chain pathway with a very low concentration of freely diffusing initiator radicals (i.e., SO_3^- , SO_4^- , $\cdot\text{OH}$).

Other heterogeneous photochemical systems that will be discussed briefly include the production of H_2O_2 (Hong et al., 1987; Kormann et al., 1988, 1989) on metal oxide surfaces, the oxidation of chloroform (Kormann et al., 1989), the oxidation of pentachlorophenol (Mills et al., 1989), and the polymerization of vinyl acetates (Hoffman et al., 1989).

References

- Boyce, S.D., M.R. Hoffmann, P.A. Hong and L.M. Moberly (1983). Catalysis of the autoxidation of aqated sulfur dioxide by homogeneous metal-phthalocyanine complexes. *Environ. Sci. Tech.*, **17**: 602-611.
- Faust, B.C., M.R. Hoffmann and D.W. Bahnemann (1989). Photocatalytic oxidation of sulfur dioxide in aqueous suspensions of $\alpha\text{-Fe}_2\text{O}_3$. *J. Phys. Chem.*, **93**: 6371-6381.
- Hawking, S.W. (1988). *A Brief History of Time*, Bantam, New York, 198 pp.
- Hoffmann, M.R. and S.D. Boyce (1983). Theoretical and experimental considerations of the catalytic autoxidation of aqueous sulfur dioxide in relationship to atmospheric systems. *Adv. Environ. Sci. Tech.*, **12**: 149-158, Wiley-Interscience, New York.

- Hoffmann, M.R. and D.J. Jacob (1984). Kinetics and mechanism of the catalytic oxidation of dissolved SO_2 in atmospheric droplets: free radical, polar and photoassisted pathways. In: *Acid Precipitation: SO_2 , NO , NO_x Oxidation Mechanisms: Atmospheric Considerations*, J.G. Calvert (ed.), Butterworth Publishers, Boston-London, pp. 101-172.
- Hong, A.P., D.W. Bahnemann and M.R. Hoffmann (1987a). Co(II) tetrasulfophthalocyanine on titanium dioxide: a new efficient relay for the photocatalytic formation and depletion of hydrogen peroxide in aqueous suspensions. *J. Phys. Chem.*, **91**: 2109-2116.
- Hong, A.P., D.W. Bahnemann and M.R. Hoffmann (1987b). Co(II) tetrasulfophthalocyanine on titanium dioxide II: photocatalytic oxidation of aqueous sulfur dioxide. *J. Phys. Chem.*, **91**: 6245-6251.
- Jacob, D.J. and M.R. Hoffmann (1983). A dynamic model for the production of H^+ , NO_3^- and SO_4^{2-} in urban fog. *J. Geophys. Res.*, **88**: 6611-6621.
- Kormann, C., D.W. Bahnemann and M.R. Hoffmann (1988). Photocatalytic production of H_2O_2 and organic peroxides in aqueous suspensions of TiO_2 , ZnO , and desert sand. *Environ. Sci. Technol.*, **22**: 798-806.
- Kormann, C., D.W. Bahnemann and M.R. Hoffmann (1989a). Environmental photochemistry: is iron oxide ($\alpha - \text{Fe}_2\text{O}_3$) an active photocatalyst? a comparative study of $\alpha - \text{Fe}_2\text{O}_3$, ZnO and TiO_2 . *J. Photochem.*, **48**: 161-169.
- Kormann, C., D.W. Bahnemann and M.R. Hoffmann (1989b). On the photolysis of aqueous solutions of organic molecules in the presence of TiO_2 suspensions. (Submitted for publication.)
- March, J. (1977). *Advanced Organic Chemistry*, 2nd ed., McGraw-Hill, New York, 1328 pp.
- Mills, G., B. Chew and M.R. Hoffmann (1989). Photocatalytic degradation of pentachlorophenol on TiO_2 . I. Intermediates and mechanism. (Submitted for publication.)
- Moore, J.W. and R.G. Pearson (1981). *Kinetics and Mechanism*, 3rd. ed., Wiley, New York, 455 pp.

5 Field Observations of UV Effects on Chemical Processes in Natural Waters

5.1 Photochemical Production of Carbonyl Sulfide in Coastal and Open Ocean Waters

Meinrat O. Andreae
Biogeochemistry Department
Max Planck Institute for Chemistry
P.O. Box 3060
D-6500 Mainz
Federal Republic of Germany

Our earlier measurements of dissolved COS in coastal waters with high organic content showed that COS is produced in the uppermost layer of the ocean and that it varies diurnally with light intensity (Ferek and Andreae, 1983; 1984). Preliminary studies suggested that the production of COS was due to photochemical processes (Ferek and Andreae, 1984). Therefore measurements were performed in open ocean areas to investigate the source characteristics of the largest area of the world oceans. COS was found to be supersaturated in almost all samples and to vary diurnally with smaller amplitude and lower concentrations than were measured in coastal areas (Figure 5.1.1). In a small number of samples, mostly those taken at night, COS was found to be slightly undersaturated. Combined with data from other marine areas (Khalil and Rasmussen, 1984), the open ocean data provide an improved estimate of $0.35 \text{ Tg S yr}^{-1}$ for the total flux of COS to the atmosphere (Table 5.1.1). Due to the steep concentration gradient between coastal and open ocean areas, the global emission of COS from the oceans is strongly dominated by the coastal regions.

References

- Ferek, R.J. and M.O. Andreae (1983). The supersaturation of carbonyl sulfide in surface waters of the Pacific Ocean off Peru. *Geophys. Res. Lett.*, **10**: 393-396.
- Ferek, R.J. and M.O. Andreae (1984). Photochemical production of carbonyl sulfide in marine surface waters. *Nature*, **307**: 148-150.
- Khalil, M.A.K. and R.A. Rasmussen (1984). Global sources, lifetimes, and mass balances of OCS and CS₂ in the earth's atmosphere. *Atmos. Envir.*, **18**: 1805.

Table 5.1.1: Average COS Concentrations and Fluxes for the World Oceans.

Biogeographic Region	Area Mio. km ²	Concentration pmol/L	Flux/Area nmol/m ² /day	Flux Gmol/yr	Flux Tg S/yr
Oligotrophic	148.3	11.3	14.0	0.8	0.024
Transition	82.8	20.3	45.0	1.4	0.044
Upwelling	86.5	24.1	64.0	2.0	0.065
Coastal/Shelf	49.4	95.0	373.0	6.7	0.22
		27.6 ^a		10.9 ^b	0.35 ^b

^aMean
^bTotal

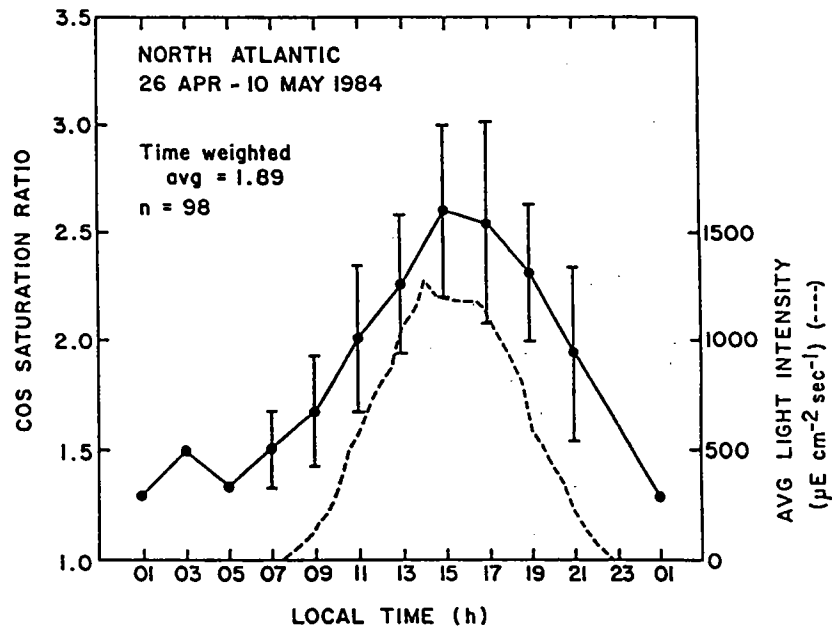

Figure 5.1.1: Means and standard errors for COS and average light intensity data from the North Atlantic cruise.

5.2 Photochemical Production of Carbon Monoxide in Surface Waters of the Pacific and Indian Oceans

¹Richard H. Gammon and ²K.C. Kelly

¹School of Oceanography
University of Washington
Seattle, Washington, 98195

²Pacific Marine Environmental Laboratory
National Oceanic and Atmospheric Administration
7600 Sand Point Way, N.E.
Seattle, Washington, 98115

The spatial and temporal coverage of the Pacific Marine Environmental Laboratory (PMEL) survey of CO in surface waters and in the atmospheric marine boundary layer consists of more than 16,000 gas chromatographic measurements of air and water CO concentrations, interleaved with an equal number of calibrations, made during more than ten months at sea during the period 1986–1989 (Figure 5.2.1). The automated system, instrumental response and calibration standards have been previously described (Kelly-Hansen and Gammon, 1986). This data set represents the most comprehensive survey of the saturation state of CO at the sea surface to date, complementary to and more extensive than the Atlantic survey of Conrad and Seiler (1982). The major findings from this earlier work (e.g., diurnal cycle of CO in the near surface waters lagging local sunlight, correlations of observed CO supersaturation with insolation and chlorophyll and inversely with wind speed) are confirmed and refined in the present study of the North and South Pacific and Indian oceans in a variety of seasons and oceanographic regimes. Preliminary results from individual cruises of this NOAA survey have been presented at AGU (Gammon and Kelly, 1988; Kelly and Gammon, 1988; Kelly-Hansen and Gammon, 1987; Kelly-Hansen and Gammon, 1986).

The surface waters of the Pacific and Indian oceans are everywhere supersaturated with carbon monoxide. The observed saturation ratio (water/air) is never less than two, more typically 5–20, ranging as high as a factor of 50. The lowest values are in low light conditions (winter hemisphere) away from frontal or upwelling regions of higher productivity. The highest levels of CO in surface water were found in the upwelling region of the eastern equatorial Pacific, in the frontal regions at the poleward edges of the subtropical gyres in both the North and South Pacific (35°–40° latitude), and in coastal or near-shore regions of high productivity and upwelling (e.g., Gulf of Alaska near the Aleutians in August, 1987). In all cases, high surface water CO correlated well with local light levels and productivity indices such as nutrients and fluorescence, and inversely with wind speed.

Measured atmospheric CO levels confirm the factor of three difference in concentration between the hemispheres and strong seasonal variation. The local diurnal variation of CO in the marine boundary layer is closely coupled to sunlight, with observed phase lags of 0–2 hours. This is distinctly different from the CO cycle in the water, which always lags the phase of the sunlight by 4–6 hours. Thus the cycle in the water cannot be responsible for the observed atmospheric diurnal variation, which must be due to fast photochemical production (e.g., photolysis of aldehydes, etc.). The amplitude of the diurnal cycle of CO

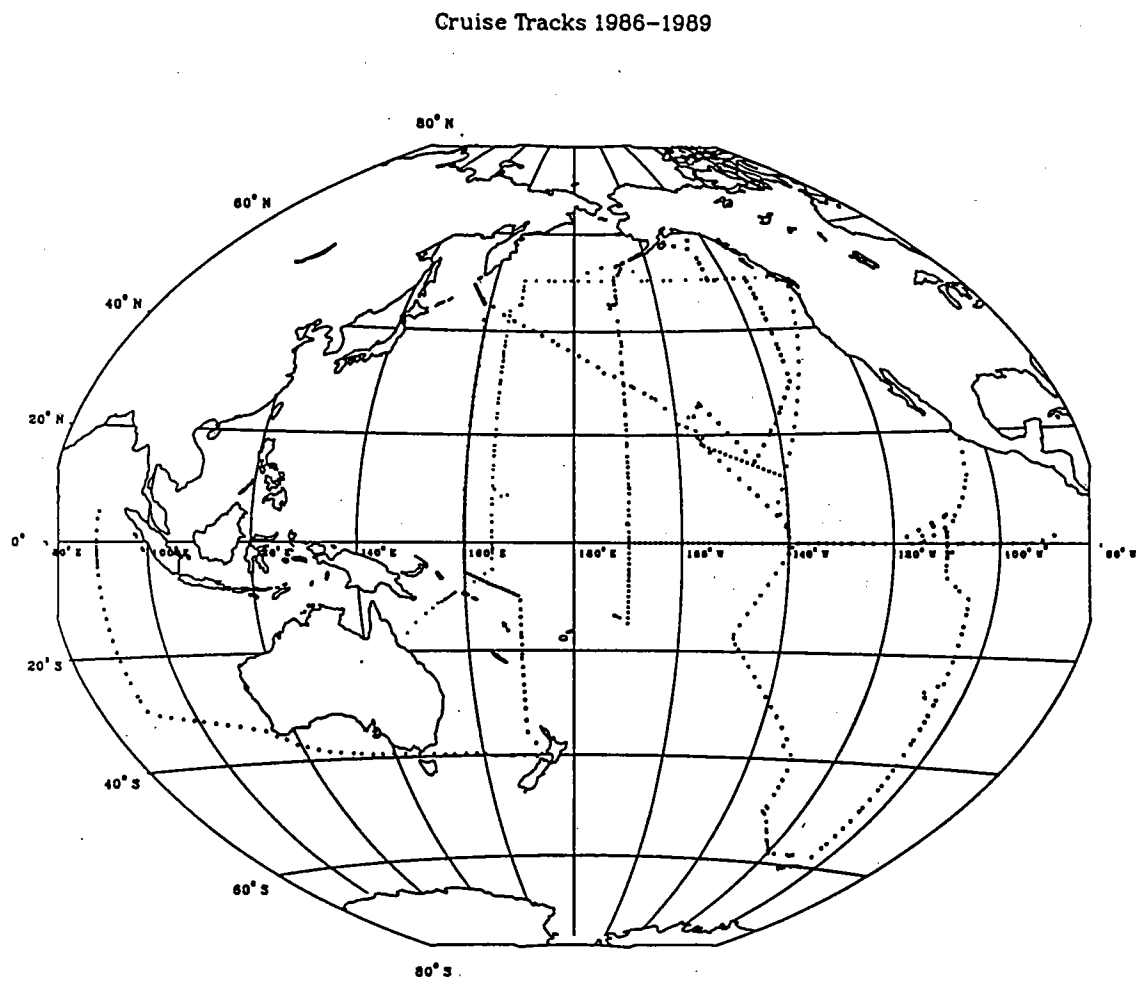

Figure 5.2.1: Cruise tracks in the North and South Pacific and Indian oceans during the period 1986-1989.

in the surface water is of the order 50–60% of the daily mean concentration, while in the overlying marine boundary layer, the peak-to-peak amplitude is approximately 10% of the mean atmospheric level in tropical latitudes, falling to 5% or less at lower light levels in the mid-latitudes. These modulations are consistent with atmospheric photochemical lifetimes of 10 to 20 days.

The present survey, combined with the earlier work of Conrad and Seiler and other investigators, suggests that the CO flux from the global ocean probably lies at the upper end of the suggested range 20–200 Tg CO per year. Since the flux to the atmosphere must be regarded as a small leakage relative to the full flux of CO in the water column (dominated by photochemical production and microbial consumption), it appears that the apparent loss rate and radiocarbon age of dissolved organic carbon in the global ocean might well be explained by photochemical production in sunlit surface waters. Future process-oriented studies are needed, with simultaneous measurements of DOC, uv flux and CO as a function of depth in the upper water column. Isotopic determinations of ^{13}C O and ^{14}C O in both the water and marine boundary layer would be especially useful.

References

- Conrad and Seiler (1982). *J. Geophys. Res.*, **87**: 8839.
- Gammon, R.H. and K.C. Kelly (1988). *EOS*, **69**: 1072.
- Kelly, K.C. and R.H. Gammon (1988). *EOS*, **69**: 1075.
- Kelly-Hansen and R.H. Gammon (1986). *EOS*, **67**: 877.
- Kelly-Hansen and R.H. Gammon (1987). *EOS*, **68**: 1220.

5.3 Hydrogen Peroxide as a Relative Indicator of the Photochemical Reactivity of Natural Waters

R.G. Zika

Rosenstiel School of Marine and Atmospheric Sciences

University of Miami

4600 Rickenbacker Causeway

Miami, Florida 33149-1098

There is a substantial amount of evidence now to show that the UPC (unknown photoreactive chromophores) fraction is the dominant photochemically active component in natural waters (Zafriou et al., 1984; Zika, 1987; Zepp, 1988; Zika and Cooper, 1987; Cooper et al., 1989; Hoigne et al., 1989) and that at least photochemically there are significant similarities between terrestrial humic materials and the UPC fraction in seawater. For the most part, the photoreactivity of the UPC fraction and of terrestrial humic materials has been demonstrated by measuring the resultant photochemical products (i.e., e_{aq}^- , H_2O_2 , singlet oxygen, O_2^- , low molecular weight organic acids and carbonyls). Many of the products identified are probably formed by secondary pathways that may involve compounds other than the photosensitizing components of the UPC. Under natural environmental conditions the major primary photoprocesses are thought to involve long-lived excited state species, best characterized as triplets whose decay is mainly via energy or electron transfer steps (Fischer et al., 1985; Zepp et al., 1985; Frimmel et al., 1987; Zepp et al., 1987; Mopper et al., 1989). Since the concentration of O_2 in surface waters is from 10^{-3} to 10^{-4} M the dominant processes involving these triplets are O_2 reduction to O_2^- and energy transfer to $^1\Delta_g O_2$. In water the lifetime of $^1\Delta_g O_2$ is on the order of microseconds, therefore in natural waters its dominant pathway is vibrational relaxation to ground state. The short lifetime and the difficulty of quantitatively measuring $^1\Delta_g O_2$ make it unattractive as a relative indicator of photoreactivity.

In natural waters O_2^- has a dominant reaction path which is to disproportionate to H_2O_2 . In a recent study it was found that approximately 70% of superoxide in coastal seawater samples reacts to form hydrogen peroxide, while the remaining 30% reacts to form unknown products (Petasne and Zika, 1987). In oligotrophic waters where the steady state concentrations of oxidants for O_2^- are probably substantially lower the percentage of superoxide disproportionating to H_2O_2 should increase. Hence the existing concentration of H_2O_2 and the rate of its formation in irradiated samples should be good indicators for measuring the capacity of seawater to initiate reactions from the UPC fraction.

During the past ten years substantial information has been compiled on the ambient concentration and the formation rate of H_2O_2 from various locations in the marine environment. The surface water concentrations vary from the extremes of 0 nM to greater than 1,000 nM. The highest concentrations and largest formation rates are found in coastal areas. High concentrations can also result from major rain events (Cooper et al., 1987). For open ocean conditions the range is typically 50 to 120 nM with variations dependent on location, time of day, season, and vertical mixing characteristics. The primary source of this H_2O_2 results from photochemistry of the UPC fraction, but biological production (Palenik

et al., 1987) and dry and wet deposition from the atmosphere also contribute (Thompson and Zafriou, 1983; Cooper et al., 1987).

The vertical concentration distribution of H_2O_2 in the ocean is typically the highest at the surface and then declines to below the detection limit at the base of the wind mixed-layer (Zika et al., 1985). Photochemical production of H_2O_2 increases sharply with increasing frequency of radiation in the solar near ultraviolet spectrum. This characteristic together with the high attenuation of ultraviolet radiation in seawater limits the zone in which greater than 95% of the H_2O_2 is introduced to less than 20 meters depth in even the most transparent regions of the ocean. The peroxide below this shallow production zone is primarily the result of wind driven thermohaline mixing. The mixed layer distribution of peroxide as well as other photochemical products and reactants can be described using one dimensional mixed layer models (Plane et al., 1987).

To make use of such models in predicting natural photochemical processes requires a comprehensive knowledge of many parameters of the system. These include the peroxide sources (i.e., photochemical, biological, and atmospheric deposition) and the sinks, and the physical parameters involved in surface layer mixing.

References

- Cooper, W.J., E.S. Saltzman and R.G. Zika (1987). The contribution of rainwater to variability in surface ocean hydrogen peroxide. *J. Geophys. Res.*, **92**: 2970-2980.
- Cooper, W.J., R.G. Zika, R.G. Petasne and A.M. Fischer (1989). Sunlight induced photochemistry of humic substances in natural waters: major reactive species. In: *Influence of Aquatic Humic Substances on Fate and Treatment of Pollutants*, P. MacCarthy and I.H. Suffet (eds.), American Chemical Society Symposium Series, vol. 219, pp. 333-362.
- Fischer, A.M., D.S. Kliger, J.S. Winterle and T. Mill (1985). Direct observation of photo-transients in natural waters. *Chemosphere*, **14**: 1299-1306.
- Frimmel, F.H., H. Bauer, J. Putzien, P.M. Murasecco and A.M. Braun (1987). Laser flash photolysis of dissolved aquatic humic material and the sensitized production of singlet oxygen. *Environ. Sci. Technol.*, **21**: 541-545.
- Hoigne, J., B.C. Faust, W.R. Haag and R.G. Zepp (1989). Aquatic humic substances as sources and sinks of photochemically produced transient reactants. In: *Influence of Aquatic Humic Substances on Fate and Treatment of Pollutants*, P. MacCarthy and I.H. Suffet (eds.), American Chemical Society Symposium Series, vol. 219, pp. 363-381.
- Mopper, K., R.G. Zika and A. Fischer (1989). Photochemistry and photophysics of marine humic substances. *Sci. Tot. Environ.*, in press.
- Palenik, G., O.C. Zafriou, F.M.M. Morel (1987). Hydrogen peroxide production by a marine phytoplankter. *Limnol. Oceanogr.*, **32**: 1365-1369.

- Petasne, R.G. and R.G. Zika (1987). The fate of superoxide in coastal seawater. *Nature*, **325**: 516-518.
- Plane, J.M.C., R.G. Zika, R.G. Zepp and L.A. Burns (1987). Photochemical modeling applied to natural waters. In: *Aquatic Photochemistry*, American Chemical Society Symposium Series, vol. 327, pp. 250-267.
- Thompson, A.M. and O.C. Zafiriou (1983). Air-sea fluxes of transient atmospheric species. *J. Geophys. Res.*, **90**: 869-875.
- Zafiriou, O.C., J. Jousot-Dubien, R.G. Zepp and R.G. Zika (1984). Photochemistry of natural waters. *Environ. Sci. Technol.*, **18**: 358A-371A.
- Zepp, R.G. (1988). Environmental photoprocesses involving natural organic matter. In: *Humic Substances and Their Role in the Environment*, F.H. Frimmel and R.F. Christman (eds.), John Wiley and Sons, Chichester, U.K., pp. 193-214.
- Zepp, R.G., A.M. Braun, J. Hoigné and J.A. Leenheer (1987). Photoproduction of hydrated electrons from natural organic solutes in aquatic environments. *Environ. Sci. Technol.*, **21**: 485-490.
- Zepp, R.G., P.F. Schlotzhauer and R.M. Sink (1985). Photosensitized transformations involving electronic energy transfer in natural waters: Role of humic substances. *Environ. Sci. Technol.*, **19**: 48-55.
- Zika, R.G. (1987). Advances in marine photochemistry 1983-1987. *Rev. Geophys.*, **25**: 1390-1394.
- Zika, R.G. and W.J. Cooper (1987). *Photochemistry of Environmental Aquatic Systems*, American Chemical Society, Washington, D.C., 288 pp.
- Zika, R.G., J. Moffett, W.J. Cooper, R. Petasne and E. Saltzman (1985). Spatial and temporal variations of hydrogen peroxide in Gulf of Mexico waters. *Geochim. Cosmochim. Acta*, **49**: 1173-1184.

5.4 Effects of Solar Ultraviolet Radiation on Geochemical Dynamics: State-of-the-art in Molecular Probes for Reactive Transients

Oliver C. Zafriou
Department of Chemistry
Woods Hole Oceanographic Institution
Woods Hole, Massachusetts 02543

The regimes of the hydrosphere which might be affected by UV-B changes, excluding direct biological effects, are:

atmospheric - clouds, fogs, aerosols, rain
natural waters - world ocean, estuaries, freshwaters
terrestrial - moist soils and vegetation surfaces

This abstract will address questions 2, 5, and 6 asked in the workshop announcement: "What do field studies indicate about which geochemical processes in the hydrosphere are most affected by present levels of solar ultraviolet radiation? How are chemical processes ... affected by increases in ultraviolet radiation? How are fundamental photochemical processes affected by changes in solar UV flux?" The emphasis is on the issue of what we have measured and are able to measure at present and how well can we measure UV-B effects.

The presentation will focus on natural waters, but it is important to note that in the author's opinion more significant effects might be expected in the other two regimes, which are much more difficult to study, simulate, or model realistically, and are in some danger of being neglected for that reason. In the hydrosphere, photochemistry is one precess taking its place alongside intense physical and biological processes that tend to dilute and buffer the system against UV-B induced change. In clouds, UV-B photoprocesses are (presumably) a much larger fraction of photochemical and total chemical reactions taking place, while on vegetation and soil surfaces at the microscopic level there is intimate contact between photoproducts and living tissues or a biogeochemically important interface, the land-air boundary.

The last few years have seen an important degree of development and initial application of various techniques to detect and measure rates of photochemical change in natural waters. The molecular probe approach is especially useful in evaluating the rates of "indirect" photoprocesses and for evaluating the fluxes of "reactive transients" (RT's) (Waite et al., 1988). The author will critically review the probe systems now available for estimating a variety of RT's in natural water systems: singlet oxygen, high-energy triplets, primary radicals, total long-lived radicals, and the specific key species alkyl, acyl, OH, and O_2^-). The need for and difficulties with probes for I atoms, alkylperoxy and acylperoxy radicals will be discussed briefly. The need for and prospects of making such measurements in clouds will also be stressed.

Field data for total long-lived radicals from several tropical/temperate marine environments will be presented along with low-resolution action spectra for their formation in sunlight. These data tend to suggest that in estuarine and seawater environments the range of total radical formation rates under full-noon-sun surface insolation conditions are of the order 0.2-20 nM per liter per minute, corresponding on an annual basis to ~20-2,000 μM

per liter per year. The action spectra resemble the absorption spectra of "Gelbstoffe"; while UV-B radiation is important, the contributions from longer wavelengths are also significant.

If these methods were to be extended and cross-calibrated they could form the basis of a research and monitoring scheme for environmental photoprocess rates generating many important reactive transients (RT's). Problems and approaches to calibrating such methods with respect to accuracy and to standardizing them with respect to long-term precision will be discussed. If sensitivity is to be maintained while improving calibration and precision, there is a need for much more flexible monochromatic high-intensity light systems and/or for more stable solar simulators with accompanying polychromatic actinometry.

Reference

- Waite, T.D., D.T. Sawyer and O.C. Zafiriou (1988). Panel 1: Oceanic reactive chemical transients. *Applied Geochem.*, **3**: 9-17.

5.5 The Role of Photochemical Processes and Hydrogen Peroxide in Iron Redox Marine Chemistry

Dana R. Kester
Graduate School of Oceanography
University of Rhode Island
Narragansett, Rhode Island 02882

There is increasing evidence that iron may be a limiting nutrient for phytoplankton growth in regions of the ocean where phosphorus and nitrogen are not fully utilized in euphotic waters (Martin and Fitzwater, 1988; Martin and Gordon, 1988). Iron(III) is the stable oxidation in seawater containing dissolved oxygen. At the pH of oceanic surface waters iron(III) tends to form hydrous oxide solid phases which upon aging result in ferric oxide phases. Iron in these oxide phases is unreactive to decreases in pH over the range 8 to 4, suggesting that aged iron oxides may be of limited availability to marine phytoplankton.

We observed photochemically-induced iron(II) formation in upwelling waters off the coast of Peru (Hong and Kester, 1986). Diel experiments in the MERL microcosms also reveal variations in Fe(II) related to light intensity. Hydrogen peroxide varied in these experiments from 50 nmol/kg before sunrise to 180 nmol/kg at 1500 hours. When the hydrogen peroxide concentration reached 124 nmol/kg it became a significant oxidant for Fe(II) and the Fe(II) concentrations were diminished during the period of the hydrogen peroxide maximum. Laboratory photochemical experiments in seawater with a solar simulator light source was used to determine the rates of Fe(II) formation, hydrogen peroxide formation, and Fe(II) oxidation when the light source is turned off.

A kinetic model for the concurrent oxidation of Fe(II) by oxygen and by hydrogen peroxide has been compared with experiments using naturally occurring Fe(II) in Narragansett Bay waters and using reagent Fe(II) additions. Fe(II) added to seawater oxidizes at a rate comparable to that predicted from laboratory rate constants for oxygen (Millero, et al., 1987) and for hydrogen peroxide (Moffett and Zika, 1987). The naturally occurring Fe(II), however, does not oxidize as quickly as freshly added Fe(II). The rate and mechanism of Fe(II) oxidation may vary with Fe(II) concentration or speciation in a manner not fully described by a simple first-order rate law with respect to Fe(II).

These studies of iron redox processes related to hydrogen peroxide and light intensity provide a mechanism by which iron in the marine environment can be continually cycled between Fe(II) and Fe(III) maintaining iron in a chemically reactive form for uptake by phytoplankton. If changes in stratospheric ozone result in increased levels of UV light in the surface waters of the ocean, the rates and the quasi-steady state concentrations of iron redox cycling could change.

References

- Hong, H. and D.R. Kester (1986). Redox state of iron in the offshore waters of Peru. *Limnol. Oceanogr.*, **31**(3): 512-524.
- Martin, J.H. and S.E. Fitzwater (1988). Iron deficiency limits phytoplankton growth in the northeast Pacific subarctic. *Nature*, **331**: 341-343.

Martin, J.H. and R.M. Gordon (1988). Northeast Pacific iron distributions in relation to phytoplankton productivity. *Deep-Sea Res.*, **35**(2): 177-196.

Millero, F.J., S. Scotolongo and M. Izaguirre (1987). The oxidation of Fe(II) in seawater. *Geochim. Cosmochim. Acta*, **51**: 793-801.

Moffett, J.W. and R.G. Zika (1987). Reaction kinetics of hydrogen peroxide with copper and iron in seawater. *Environ. Sci. Technol.*, **21**(8): 804-810.

5.6 Chemical Reactions Affected by UV Irradiation in the Oceans and their Influence on Primary Productivity: Some General Considerations

**James W. Moffett
Department of Chemistry
Woods Hole Oceanographic Institution
Woods Hole, Massachusetts 02543**

A variety of chemical reactions are mediated by sunlight. Many of these may influence biological activity, particularly for organisms which are sensitive to their chemical environment. For instance there is considerable evidence from field studies which indicates that photochemical reactions influence the chemistry of the trace elements Fe, Cu, and Mn (Waite and Morel, 1984; Moffett and Zika, 1987, 1988; Sunda et al., 1983) in surface waters leading to an increase in their availability to organisms. The reactions involved in these processes are poorly understood so it is important to consider primary productivity from a biological oceanographic perspective to determine what constraints can be placed on the importance of these processes. This will be useful in establishing priorities for future work.

Firstly, it should be noted that in most well stratified marine environments, maximum primary productivity occurs well below the penetration of UV-B irradiation. This is not because of UV inhibition of biological activity but because of nutrient depletion in surface waters. Consequently, reactions mediated by UV-B irradiation will only have a major effect on primary productivity if they lead to long term perturbations which affects the lower photic zone through mixing. Alternatively, reactions which influence the light field in the lower photic zone, such as photobleaching of dissolved organic matter, may be important. Under well mixed conditions however, substantial levels of nutrients and primary productivity occur at the surface, and so photochemical processes occurring on shorter time scales (including direct photoinhibition of biological activity) will have a greater overall impact on primary productivity. Furthermore, well mixed regimes predominate in high latitude environments such as the Southern Ocean, where stratospheric ozone depletion is greatest.

In some ocean regions, relatively high nutrient levels persist in surface waters even under well stratified conditions. Martin and coworkers (1988) have proposed that this is due to Fe limitation of primary production. Photochemical reactions are likely to be of importance under these conditions because of a) higher biological activity in surface waters and b) potential involvement of Fe in photochemical reactions (Kester, preceding abstract).

One of the most exciting developments in biological oceanography in recent years has been the recognition of the role of prokaryotic phytoplankton in primary productivity, such as cyanobacteria (Waterbury et al., 1988) and the even smaller, more abundant prochlorophyte, characterized using flow cytometry by Chisholm et al. (1988). Culture studies indicate that these organisms are extremely sensitive to their chemical environment, being sensitive to even small changes in the activities of metals such as copper (Brand et al., 1986). Eukaryotic phytoplankton such as diatoms and coccolithophores are much less sensitive. Photochemical reactions which affect the availability of certain metals may place certain phytoplankton groups at a competitive advantage or disadvantage and contribute to the spatial and temporal variability of natural phytoplankton assemblages. This vari-

ability has important implications for C cycling and for the production of such important species as DMS, which is produced by only certain classes of phytoplankton.

References

- Brand, L.E., W.G. Sunda, Guillard, R.R.L. (1986). Reduction of marine phytoplankton reproduction rates by copper and cadmium. *J. Exp. Mar. Biol. Ecol.*, **96**: 225-250.
- Chisholm, S.W., R.J. Olsen, E.R. Zettler, R. Goericke, J.G. Waterbury and N.A. Welschmeyer (1988). A novel free-living prochlorophyte abundant in the oceanic euphotic zone. *Nature*, **334**: 340-343.
- Martin, J.H. and S.E. Fitzwater (1988). Iron deficiency limits phytoplankton growth in the northeast Pacific subarctic. *Nature*, **331**: 341-343.
- Moffett, J.W. and R.G. Zika (1987). The photochemistry of copper complexes in seawater. In: *Photochemistry of Environmental Aquatic Systems*, R.G. Zika and W.J. Cooper (eds.), *Advancements in Chemistry Series 327*, American Chemical Society, Washington, D.C., pp. 116-130.
- Moffett, J.W. and R.G. Zika (1988). Measurement of copper(I) in surface waters of the subtropical Atlantic and Gulf of Mexico. *Geochim. Cosmochim. Acta*, **52**: 1849-1857.
- Sunda, W.G., S.A. Huntsman and G.R. Harvey (1983). Photoreduction of manganese oxides and the supply of manganese to marine plants. *Nature*, **301**: 234-236.
- Waite, T.D. and F.M.M. Morel (1984). Photoreductive dissolution of colloidal iron oxides in natural waters. *Envir. Sci. Technol.*, **18**: 860.
- Waterbury, J.B. S.W. Watson, F.W. Valois and D.G. Franks (1987). Biological and ecological characterization of the marine cyanobacterium *Synechococcus*. In: *Photosynthetic Picoplankton*, T. Platt and W.K.W. Li (eds.), *Canadian Bulletin of Fisheries and Aquatic Sciences*, p. 214.

5.7 Phototransformation of Chemicals in Rice Paddies

Donald G. Crosby
 Department of Environmental Toxicology
 University of California, Davis
 Davis, California 95616

Solar UV energy brings about transformations in many chemicals dissolved in water (Zepp and Cline, 1977; Crosby, 1972). While the concentrations of xenobiotics in most natural waters usually are very low (10^{-6} – 10^{-7} M) pesticides often are present in the world's 150 million hectares of rice paddy water at as much as 10^{-4} M and can be used readily as probes into geochemical dynamics in aquatic environments in general (Crosby, 1983; Chen, 1983). Pesticides such as the widely-used phenoxy herbicide, MCPA, typically undergo direct photolysis via ring- and sidechain oxidation, reduction, and photonucleophilic substitution (see diagram) (Soderquist and Crosby, 1974; Crosby and Bowers, 1985; Benoit-Guyod et al., 1986). They also undergo indirect oxidation by hydroxyl radicals generated photochemically from natural solutes including tryptophan, nitrate, nitrite, and hydrogen peroxide (Ross and Crosby, 1985; Zafiriou and True, 1979; Draper and Crosby, 1981).

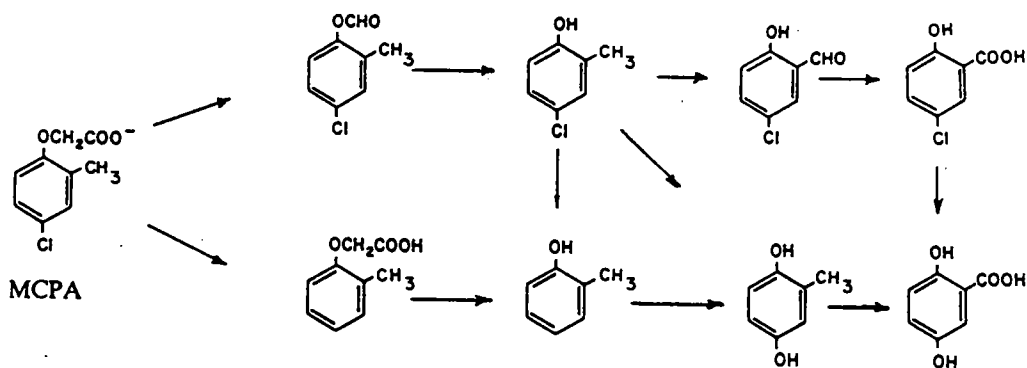

Many of the most common rice pesticides absorb UV energy broadly near the 290 nm solar radiation cutoff (Crosby, 1988; Sadtler, 1969); an increase in solar intensity and/or a shift of the cutoff to shorter wavelengths can be predicted to increase their degradation rates. The same will be true for indirect photolysis through increased generation of hydroxyl. The practical consequences could include both a decreased persistence of water pollutants and the necessity of increased pesticide use.

References

- Benoit-Guyod, J.-L., J.G. Bowers and D.G. Crosby (1986). *Water Res.*, 20: 67–72.
- Chen, Y.L. (1983). In: *Weed Control in Rice*, IRRI, Los Baños, Philippines, pp. 385–399.
- Crosby, D.G. (1972). *Adv. Chem. Ser.*, 111: 173–188.

- Crosby, D.G. (1983). In; *Pesticide Chemistry: Human Welfare and the Environment*, J. Miyamoto and P.C. Kearny (eds.), Pergamon Press, N.Y., Vol. 2, pp. 339-346.
- Crosby, D.G. (1988). In: *Proceedings of an International Conference on Pesticides in Tropical Agriculture*, K.Y. Lum (ed.), MARDI, Kuala Lumpur, Malaysia.
- Crosby, D.G. and J.B. Bowers (1985). *J. Agr. Food Chem.*, **33**: 569-573.
- Draper, W.M. and D.G. Crosby (1981). *J. Agr. Food Chem.*, **29**: 699-702.
- Ross, R.D. and D.G. Crosby (1985). *Envir. Toxicol. Chem.*, **4**: 773-778.
- Sadtler (1969). *Agricultural Chemicals Ultraviolet Spectra*, Sadtler Research Laboratories, Philadelphia, PA.
- Soderquist, C.J. and D.G. Crosby (1974). *Pestic. Sci.*, **6**: 17-33.
- Zafiriou, O.C. and M.B. True (1979). *Geophys. Res. Lett.*, **6**: 81-84.
- Zepp, R.G. and D.M. Cline (1977). *Envir. Sci. Technol.*, **11**: 359-366.

6 UV Effects on Homogeneous Chemical Processes

6.1 Effects of Solar Ultraviolet Radiation on Photochemical Processes in Natural Waters

Richard G. Zepp
Environmental Research Laboratory
U.S. Environmental Protection Agency
Athens, Georgia 30613

Introduction

Recent studies have shown that the marine photochemical formation rates of carbon monoxide (Gammon and Kelley, 1988; Conrad et al., 1982) and carbonyl sulfide (Ferek and Andreae, 1984) vary greatly in different types of sea water. Other studies have shown that sunlight-induced reaction rates of a given organic substance in various natural water samples can vary by orders of magnitude (Skurlatov et al., 1983; Simmons and Zepp, 1986; Haag and Hoigné, 1986; Larson and Zepp, 1988). This great variability largely can be attributed to changes in the nature and concentration of short-lived transient reactants that are produced photochemically in natural waters (Zafiriou et al., 1984; Hoigné et al., 1988; Cooper et al., 1988; Zepp, 1988; Haag and Mill, 1989). Transients that have been identified thus far include singlet molecular oxygen, triplet states, hydroxyl radicals, superoxide radicals, organoperoxy radicals, carbonate radicals, solvated electrons, and hydrogen peroxide. In addition to their involvement in various chemical processes, some of these transients are likely to interact in various ways with biological systems, producing toxic effects or, in the case of peroxides, activating enzymes such as haloperoxidases that produce halocarbons in the sea. In this paper, I briefly discuss experimental approaches to the study of these transient reactants. Then, I focus on results that demonstrate the important role played by solar ultraviolet radiation in inducing these photochemical processes.

Experimental Approaches

Two general approaches have been used to examine the transient reactants involved in photochemical processes in natural waters, laser flash photolysis and continuous irradiations. With the important exception of hydrogen peroxide (Cooper et al., 1988; Petasne and Zika, 1987), the transient reactants involved in these photoreactions are usually very short-lived and too dilute to be directly observed on continuous irradiation by commonly used light sources. In some cases, it is possible to directly observe these transients through laser flash photolysis (Fischer et al., 1987; Frimmel et al., 1987; Kanner et al., 1989; Power et al., 1987; Zafiriou and Bonneau, 1987; Zepp et al., 1987a). Triplet states, singlet oxygen, and solvated electrons have been studied using this technique. Such laser studies involve irradiation by a very short, intense pulse of light. The formation and decay of the transients can be detected spectrometrically or conductometrically. When absorption spectrometry is used for detection, the time evolution of the electronic absorption spectrum of the transient(s) can be obtained. Presently available equipment permits studies within time domains in the picosecond range.

In most cases, the identity and concentration of transients produced on irradiation of natural waters have been inferred indirectly through steady-state analysis of kinetic results obtained in continuous irradiations with monochromatic light or with sunlight (Zepp, 1988; Waite et al., 1988; Hoigné et al., 19889; Cooper et al., 1988). This approach involves the addition of a readily detected "probe" substance to the system that reacts with the transient in a well defined way. For example, nitroxides have been used to scavenge photochemically produced free radicals (Blough, 1988), halocarbons to trap solvated electrons (Zepp et al., 1987a), and aromatic amines have been used to investigate carbonate radicals (Larson and Zepp, 1988). In my presentation, I will discuss direct comparisons between data obtained by the continuous irradiation and laser flash photolysis techniques. My discussion will focus on the photoproduction of singlet oxygen, triplet states, and solvated electrons on irradiation of natural organic solutes with ultraviolet radiation.

Effects of Solar Ultraviolet Radiation

The transient reactants are produced on light absorption by various inorganic and organic chromophores in marine and freshwater environments. Wavelength effects on the transient formation rates and concentrations have been quantified in a limited number of studies. These studies generally have shown that ultraviolet radiation is mainly responsible for inducing transient formation. Photoproduction rates of transients from a well-defined chromophore can be estimated using the scalar irradiance, electronic absorption spectrum of the chromophore, and quantum yields for transient production. Such studies have demonstrated, for example, that production of hydroxyl radicals by sunlight irradiation is primarily induced by ultraviolet-B radiation (280–320 nm) in the case of nitrate (Zepp et al., 1987b; Warneck and Wurzinger, 1988) and by ultraviolet-A radiation in the case of nitrite (Zafiriou and Bonneau, 1987). I present evidence here that ultraviolet radiation also is most important in the photoinduced production of free radicals from organic complexes of iron and copper.

In the case of poorly-defined chromophores such as those that comprise the dissolved organic matter in marine and freshwater environments, wavelength studies have primarily involved obtaining action spectra and/or quantum yields for transient production. For example, it has been shown that the formation of singlet oxygen and triplet states (Figure 6.1.1) and of hydrogen peroxide (and thus of superoxide ions) (Figure 6.1.2) is mainly induced by solar ultraviolet radiation, especially by the ultraviolet-B portion (280–320 nm). Available data indicate that superoxide formation is more strongly influenced by ultraviolet-B radiation than is formation of triplets and singlet oxygen.

References

- Blough, N.V. (1988). Electron paramagnetic resonance measurements of photochemical radical production in humic substances. 1. Effects of O₂ and charge on radical scavenging by nitroxides. *Environ. Sci. Technol.*, **22**:77–82.
- Conrad, R., W. Seiler, G. Bunse and H. Giehl (1982). Carbon monoxide in sea water (Atlantic Ocean). *J. Geophys. Res.*, **87**: 8839–8852.

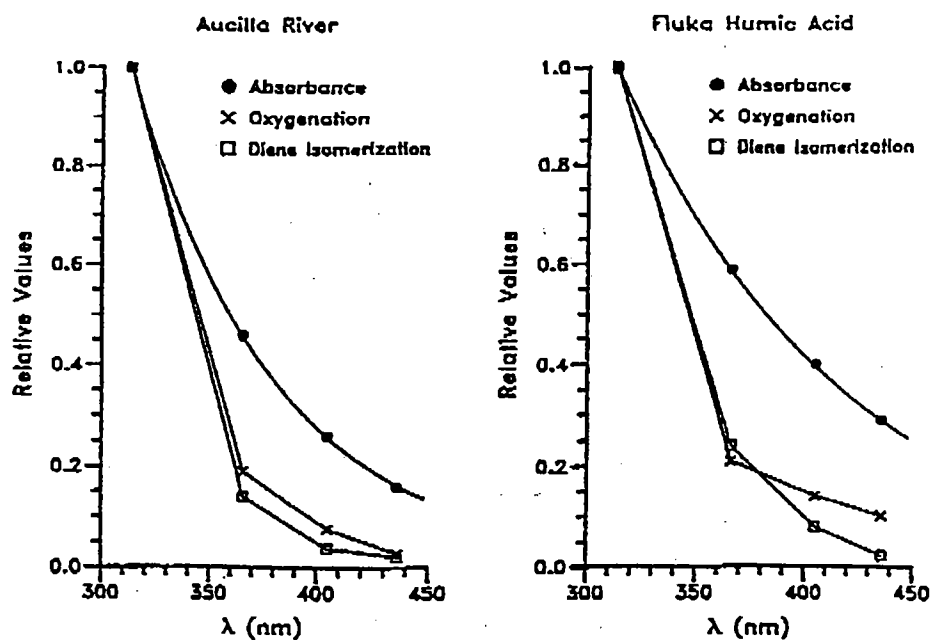

Figure 6.1.1: Action spectra for oxygenation (singlet oxygen formation) and diene isomerization (triplet formation) in natural water sample (Zepp et al., 1985).

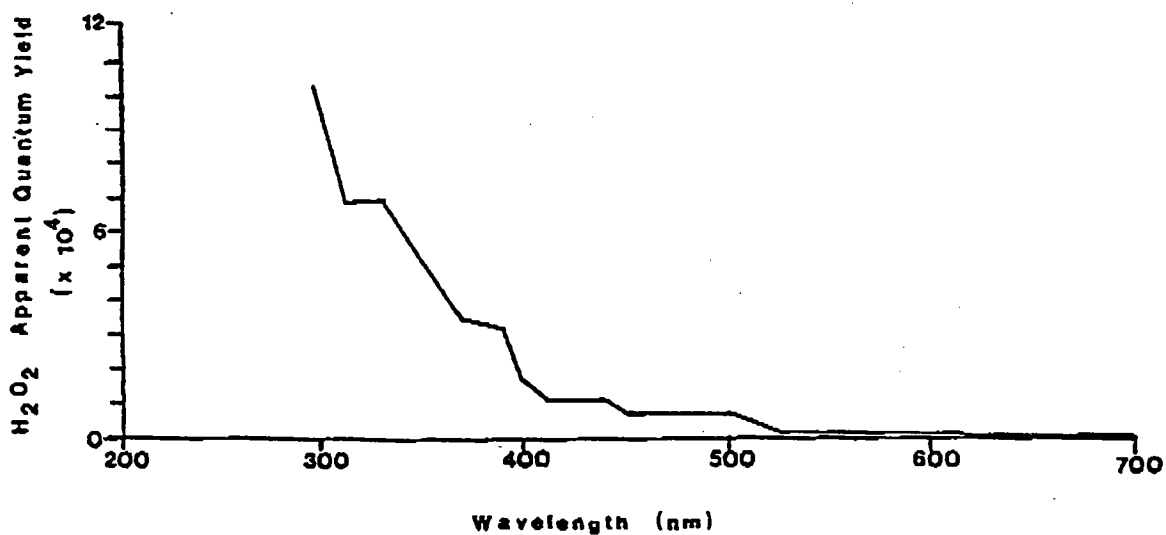

Figure 6.1.2: Wavelength dependence for the photochemical formation of hydrogen peroxide in natural water samples (Cooper et al., 1988).

- Cooper, W.J., Zika, R.G., R.G. Petasne and A.M. Fischer (1988). Sunlight induced photochemistry of humic substances in natural waters: major reactive species. In: *Influence of Aquatic Humic Substances on Fate and Treatment of Pollutants*, P. MacCarthy and I.H. Suffet (eds.), ACS Symposium Series 219, Washington, D.C., pp. 333-362.
- Ferek, R.J. and M.O. Andreae (1984). Photochemical production of carbonyl sulfide in marine surface waters. *Nature*, **307**: 148-150.
- Fischer, A.M., J.S. Winterle and T. Mill (1987). Primary photochemical processes in photolysis mediated by humic substances. In: *Photochemistry of Environmental Aquatic Systems*, R.G. Zika and W.J. Cooper (eds.), ACS Symposium Series 327, pp. 141-156.
- Frimmel, F.H., H. Bauer, J. Putzien, P. Murasecco and A.M. Braun (1987). Laser flash photolysis of dissolved aquatic humic material and the sensitized production of singlet oxygen. *Environ. Sci. Technol.*, : 541-545.
- Gammon, R.H. and K.C. Kelley (1988). Reassessment of the flux of CO from the global ocean to the atmosphere. *Trans. Am. Geophys. Union*, **69**: 1072.
- Haag, W.R. and J. Hoigné (1986). Singlet oxygen in surface waters - Part III. Photochemical formation and steady-state concentrations in various types of waters. *Environ. Sci. Technol.*, **20**: 341-348.
- Haag, W.R. and T. Mill (1989). Survey of sunlight-produced transient reactants in surface waters. (Paper presented at the Workshop on Effects of Solar Ultraviolet Radiation on Geochemical Dynamics, Woods Hole, MA.)
- Hoigné, J., B.C. Faust, W.R. Haag and R.G. Zepp (1988). Aquatic humic substances as sources and sinks of photochemically produced transient reactants. In: *Influence of Aquatic Humic Substances on Fate and Treatment of Pollutants*, P. MacCarthy and I.H. Suffet (eds.), ACS Symposium Series 219, Washington, D.C. pp. 363-384.
- Kanner, R., R.G. Zepp and C.S. Foote (1989). Laser flash photolytic studies of singlet molecular oxygen production from humic substances. (in preparation).
- Larson, R.A. and R.G. Zepp (1988). Reactivity of the carbonate radical with aniline derivatives. *Environ. Toxicol. Chem.*, **7**: 265-274.
- Petasne, R.G. and R.G. Zika (1987). Fate of superoxide in coastal sea water. *Nature*, **325**: 516-518.
- Power, J.F., D.K. Sharma, C.H. Langford, R. Bonneau and J. Jousset-Dubien (1987). Laser flash photolytic studies of a well-characterized soil humic substance. In: *Photochemistry of Environmental Aquatic Systems*, R.G. Zika and W.J. Cooper (eds.), ACS Symposium Series 327, Washington, D.C., pp. 157-173.
- Simmons, M.S. and R.G. Zepp (1986). Influence of humic substances on photolysis of nitroaromatic compounds in aqueous systems. *Water Res.*, **20**: 899-904.

- Skurlatov, Y.I., R.G. Zepp and G.L. Baughman (1983). Photolysis rates of (2,3,5-Trichlorophenoxy)acetic acid and 4-amino-3,5,6-trichloropicolinic acid in natural waters. *J. Ag. Food Chem.*, **31**: 1065-1071.
- Waite, T.D., D.T. Sawyer and O.C. Zafiriou (1988). Panel 1: Oceanic reactive chemical transients. *Appl. Geochem.*, **3**: 9-17.
- Warneck, P. and C. Wurzinger (1988). Product quantum yield for the 305-nm photodecomposition of NO_3^- in aqueous solution. *J. Phys. Chem.*, **92**: 6278-6283.
- Zafiriou, O.C., J. Jousset-Dubien, R.G. Zepp and R.G. Zika (1984). Photochemistry of natural waters. *Environ. Sci. Technol.*, **18**: 358A-371A.
- Zafiriou, O.C. and R. Bonneau (1987). Wavelength-dependent quantum yield of OH radical formation from photolysis of nitrite ion in water. *Photochem. Photobiol.*, **45**: 723-727.
- Zepp, R.G. (1988). Environmental photoprocesses involving natural organic matter. In: *Humic Substances and Their Role in the Environment*, F.H. Frimmel and R.F. Christman (eds.), Wiley & Sons Ltd., London, pp. 193-213.
- Zepp, R.G., A.M. Braun, J. Hoigné and J. Leenheer (1987a). Photoproduction of hydrated electrons from natural organic solutes in aquatic environments. *Environ. Sci. Technol.*, **21**: 485-490.
- Zepp, R.G., J. Hoigné and H. Bader (1987b). Nitrate-induced photooxidation of trace organic chemicals in water. *Environ. Sci. Technol.*, **21**: 443-450.

6.2 Optical Detection of Photogenerated Free Radical Intermediates in Natural Waters

Neil V. Blough
Department of Chemistry
Woods Hole Oceanographic Institution
Woods Hole, Massachusetts

A major hurdle to our understanding of the impact of Type I (free radical) photooxidative processes in natural waters is the lack of methods which can identify, with high sensitivity and selectivity, free radical intermediates. Because of their high reactivity and oftentimes low rates of formation, steady-state concentrations of these species are usually quite low and are generally impossible to detect directly by spectroscopic methods. As an alternative to direct detection, aliphatic aminoxyl radicals (nitroxides) have been employed increasingly to trap and identify transient free radicals (Gerlock and Bauer, 1984; Beckwith et al., 1988; Blough, 1988; Jones et al., 1989; Beckwith and Bowry, 1989). Nitroxides react quite rapidly with carbon-centered radicals (10^8 - 10^9 $M^{-1} s^{-1}$), but not with most oxygen-centered radicals, to form stable, diamagnetic alkoxyamine and hydroxylamine products (Willson, 1971; Nigam et al., 1976; Gerlock and Bauer, 1984; Beckwith et al., 1988; Blough, 1988; ; Chateaufneuf et al., 1988; Jones et al., 1989; Beckwith and Bowry, 1989). Separation of products by high performance liquid chromatography (HPLC) can allow for the identification of specific free radicals (Beckwith et al., 1988; Beckwith and Bowry, 1989; Jones et al., 1989). Formation rates of carbon-centered radicals have been estimated by following the loss of nitroxide with electron paramagnetic resonance (EPR) spectroscopy (Gerlock and Bauer, 1984; Blough, 1988).

The sensitivity achieved for the detection of radicals trapped by nitroxides can be substantially improved by employing compounds in which the nitroxide is covalently linked to a fluorophore. We previously demonstrated (Blough and Simpson, 1988) that covalently-linked, nitroxide-fluorophore adducts exhibit very low fluorescence owing to efficient intramolecular quenching of the fluorophore by the nitroxide. However, reaction of the nitroxide moiety with radicals leads to formation of diamagnetic products, thereby eliminating the intramolecular quenching pathway and resulting in enhanced fluorescence that can be used as a very sensitive measure of the extent of radical/redox scavenging. We have shown that this approach can be used to measure radical fluxes optically (Blough and Simpson, 1988; Kieber and Blough, 1989; Gerlock et al., 1989) as well as to separate and identify very low concentrations of carbon-centered radical adducts by HPLC with fluorescence detection (Kieber and Blough 1989a, 1989b). Preliminary results obtained from the application of this method to the study of photochemical radical formation in a suite of natural water samples will be presented. This approach should be broadly applicable to the study of radical processes in biological and chemical systems.

References

- Beckwith, A.L.J. and V.W. Bowry (1989). Kinetics and regioselectivity of ring opening of substituted cyclopropylmethyl radicals. *J. Org. Chem.*, 54: 2681-2688.

- Beckwith, A.L.J., V.W. Bowry and G. Moad (1988). Kinetics of the coupling reactions of the nitroxyl radical 1,1,3,3-tetramethylisoindoline-2-oxyl with carbon-centered radicals. *J. Org. Chem.*, **53**: 1632-1641.
- Blough, N.V. (1988). Electron paramagnetic resonance measurements of photochemical radical production in humic substances. 1. Effects of O₂ and charge on radical scavenging by nitroxides. *Environ. Sci. Technol.*, **22**: 77-82.
- Blough, N.V. and D.J. Simpson (1988). Chemically mediated fluorescence yield switching in nitroxide-fluorophore adducts: Optical sensors of radical/redox reactions. *J. Am. Chem. Soc.*, **110**: 1915-1917.
- Chateaneuf, J., J. Lutztyk and K.U. Ingold (1988). Absolute rate constants for the reactions of some carbon-centered radicals with 2,2,6,6-tetramethyl-piperidine-N-oxyl. *J. Org. Chem.*, **53**: 1629-1632.
- Gerlock, J.L. and D.R. Bauer (1984). ESR measurements of free radical photoinitiation rates by nitroxide termination. *J. Polymer Sci.: Polymer Lett. Ed.*, **22**: 447-455.
- Gerlock, J.L., P.J. Zacmanidis, D.R. Bauer, D.J. Simpson, N.V. Blough and I.T. Salmeen (1989). Fluorescence detection of free radicals by nitroxide scavenging. *Free Radical Res. Comm.*, (in press).
- Jones, M.J., G. Moad, E. Rizzardo and D.H. Solomon (1989). The philicity of tert-butoxy radicals. What factors are important in determining the rate and regiospecificity of tert-butoxy radical addition to olefins? *J. Org. Chem.*, **54**: 1607-1611.
- Kieber, D.J. and N.V. Blough (1989a). Fluorescence detection of carbon-centered radicals in aqueous solution. *Free Radical Res. Comm.*, (in press).
- Kieber, D.J. and N.V. Blough (1989b). Determination of carbon-centered radicals in aqueous solution by high performance liquid chromatography with fluorescence detection. *Anal. Chem.*, (to be submitted).
- Nigam, S., K.-D. Asmus and R.L. Willson (1976). Electron transfer and addition reactions of free nitroxyl radicals with radiation induced radicals. *J. Chem. Soc., Faraday Trans.*, **1**: 2324-2340.
- Willson, R.L. (1971). Pulse radiolysis studies on reaction of triacetoneamine-N-oxyl with radiation-induced free radicals. *Trans. Faraday Soc.*, **67**: 3008-30019.

6.3 Photochemistry of Dissolved Organic Matter: An Organic Geochemical Perspective

John R. Ertel

Department of Geology and Marine Science Program

University of Georgia

Athens, Georgia 30602

Riverine and oceanic dissolved organic carbon (DOC) represent the largest active reservoirs of organic matter in the world and thus are major and dynamic components in the global carbon cycle. The annual flux of total organic carbon (TOC) from rivers is about 400 Tg/yr which amounts to 1–2% of the net primary productivity in the basins (Meybeck, 1981). About half of the riverine TOC flux is dissolved (200 Tg/yr) and most of this DOC (50–70%) can be classified operationally as aquatic humic and fulvic acids (Thurman, 1985). In spite of high rates of respiration in major rivers like the Amazon, few changes are seen either in the flux or the chemical composition of the aquatic humic substances (Ertel et al., 1986), suggesting that most of the DOC in transit in rivers is resistant to microbial remineralization. Both laboratory (Sholkovitz, 1978) and field (Mantoura and Woodward, 1982) studies suggest that, with the exception of the minor (5%) humic acid fraction, riverine DOC behaves conservatively in estuaries and thus could be a major source of DOC to the oceans.

The fate of this terrestrial DOC in the oceans is not well understood. Assuming that the riverine DOC reaches the ocean at the rate of 200 Tg/yr and is as biologically refractory there as it appears to be in rivers, then the deep ocean will be filled with terrestrial carbon in 3,000 yrs or in half the present radiocarbon calculated residence time of deep ocean DOC. Even using the dissolved humic substance flux of 120 Tg/yr would completely fill the ocean with terrestrial DOC. Existing data indicates that riverine DOC, particularly the fulvic acid fraction, contains present day carbon (Hedges et al., 1986), so significant "aging" of the organic carbon does not occur in the basins prior to export and thus must occur in the oceans. However, all the spectroscopic, molecular and isotopic data for DOC in the deep ocean indicate that the biological source of this material is primarily marine phytoplankton, with little terrestrially derived carbon present. Mass balance calculations suggest that there is insufficient terrestrial carbon stored in continental shelf sediments to account for the particulate carbon flux from rivers (Ittekkot, 1988) and thus sediments cannot be a repository for the even larger riverine DOC flux. These results suggest that a significant sink for riverine DOC in the ocean must exist and existing data suggests that it is at least a partially abiotic remineralization process.

Photooxidation of DOC in the photic zone of the ocean yields low molecular weight carbonyls at sufficient rates to suggest that photochemical processes could be significant in the remineralization of refractory DOC like humic substances (Mopper et al., 1987; Kieber et al., 1989). My research is directed at determining the effect that photooxidation has on the macromolecular component of riverine and marine DOC, particularly with regard to chemical structures used to distinguish biological sources—molecular biomarkers. Much of the aquatic humic substances in rivers result from microbial degradation or leaching of vascular plant material in soils and thus contains a vascular plant source marker—lignin.

Lignin is a phenolic polymer found only in vascular plants and can be selectively depolymerized by CuO oxidation into clearly recognizable simple molecules, lignin-derived phenols. These lignin-phenols also contain within their distributions information about the relative degree of microbial degradation of the lignin (Hedges et al., 1988). Dissolved lignin, which is generally more degraded than the original plant material but still polymeric, is a ubiquitous component of riverine humic and fulvic acids (Ertel et al., 1986; Ertel, unpublished); and can be used as an unambiguous tracer for terrestrial carbon in the marine environment (Meyers-Shulte and Hedges, 1986), assuming it is a geochemically stable component. However, based on very limited data, mass balance calculations indicate that the residence time of dissolved lignin in the ocean is about 250 years or less than one-tenth that calculated for terrestrial DOC. Thus, geochemical processes in the marine environment appear to selectively remove the lignin component fluxing out of rivers; and photooxidation of the aromatic lignin component is one of the possible mechanism we are currently investigating.

Initial experiments with blackwater from the Suwannee River indicate that the recognizable lignin components and the color are removed within one month of exposure to pyrex-filtered sunlight, while no changes occur in poisoned (or unpoisoned) dark controls stored for one year. Concentrated solutions of fulvic acids isolated from the Suwannee River and the Ogeechee River using XAD-8 resin were photooxidized in laboratory experiments using a pyrex-filtered mercury vapor lamp. In both cases lignin concentrations (as determined by CuO oxidation products) decreased with time at rates much faster than changes in DOC concentrations or fluorescence (350/450) or UV adsorption. For the Ogeechee FA lignin dropped to 25% of the initial value in the first 24 hours, while no change occurred in DOC and only a 10% decrease in fluorescence was observed. These results suggest that lignin, although biologically stable, is photochemically labile and preferentially destroyed relative to riverine DOC. Thus, lignin-derived phenols as determined by this technique, are perhaps not conservative tracers for terrestrial DOC in the ocean.

References

- Ertel, J.R., J.I. Hedges, A.H. Devol, J.E. Richey and N. Ribeiro (1986). Dissolved humic substances of the Amazon River system. *Limnol. Oceanogr.*, **31**: 739-754.
- Hedges, J.I., J.R. Ertel, P.D. Quay, P.M. Grootes, J.E. Richey, A.H. Devol, G.W. Farwell, F.H. Schmidt and E. Salati (1986). Organic carbon-14 in the Amazon River system. *Science*, **231**: 1129-1131.
- Hedges, J.I., R.A. Blanchette, K. Weilky and A.H. Devol (1988). Effects of fungal degradation of the CuO oxidation products of lignin: A controlled laboratory study. *Geochim. Cosmochim. Acta*, **52**: 2717-2726.
- Ittekkot, V. (1988). Global trends in the nature of organic matter in river suspensions. *Nature*, **332**: 436-438.
- Kieber, D.J., J. McDaniel and K. Mopper (1989). Photochemical sources of biological substrates in sea water: Implications for carbon cycling. *Nature*, **341**: 637-639.
- Mantoura, R.F. and E.M. Woodward (1983). Conservative behavior of riverine dissolved organic carbon in the Severn estuary. *Geochim. Cosmochim. Acta*, **47**: 1293-1309.

- Meybeck, M. (1981). River transport of organic carbon to the ocean. In: *Flux of Organic Carbon by Rivers to the Ocean*, G. Likens, F. Mackenzie, J. Richey, J. Sedell and K. Turekian (eds.), Conf. 8009140, DOE, Office of Energy Res., Washington, D.C., pp. 219-269.
- Meyers-Shulte, K. and J.I. Hedges (1986). Molecular evidence for a terrestrial component of organic matter dissolved in ocean water. *Nature*, **321**, 61-63.
- Mopper, K. R. Sikorski, D. Kieber and J. McDaniel (1987). Photochemical incorporation and fragmentation of DOM in relation to oceanic carbon cycling. *EOS*, **68**: 1752.
- Sholkovitz, E.R. (1976). Flocculation of dissolved organic and inorganic matter during mixing of river water and sea water. *Geochim. Cosmochim. Acta*, **40**: 834-845.
- Thurman, E.M. (1985). *Organic Geochemistry of Natural Waters*. Martinus Nijhoff/Dr. W. Junk Publishers, Dordrecht, The Netherlands.

6.4 Survey of Sunlight-Produced Transient Reactants in Surface Waters

Werner R. Haag and Theodore Mill
Chemistry Laboratory
SRI International
Menlo Park, California 94025

In natural waters, absorption of sunlight by dissolved organic and inorganic compounds generates a variety of transient species including excited state dissolved organic materials (^3DOM), singlet oxygen ($^1\text{O}_2$), peroxy radicals ($\text{ROO}\cdot$), hydroxyl radicals ($\text{HO}\cdot$), solvated electrons (e_{aq}^-), and superoxide ion (O_2^-) (Faust and Hoigné, 1987; Fischer et al., 1985; Haag and Hoigné, 1985, 1986; Haag et al., 1984a, 1984b; Mill et al., 1980; Petasne and Zika, 1987; Russi et al., 1982; Zepp et al., 1985, 1987a, 1987b). The primary reason for their interest is that they can effect transformations of many natural and man-made compounds. Such transformation can be beneficial, such as in the detoxification of pesticides (Ross and Crosby, 1985), harmful, such as in the production of toxic peroxidic compounds in the photo-oxidation of crude oils (Larson et al., 1977), or of interest for the understanding of biogeochemical cycles including sulfur, nitrogen, carbon and metals. These transients do not pose a direct threat to human health because no significant exposure route exists. Ecological effects on lower organisms have been suggested (Baxter and Carey, 1982), and we examine this possibility in a separate paper (Mill et al., 1989). Any increase in UV radiation will increase the production of all these transients.

In the present paper we summarize the current understanding of the sources, sinks, and steady-state concentrations of these reactive transients (see Figure 6.4.1 and Table 6.4.1). The bulk ($\geq 90\%$) of sunlight absorbed by DOM is converted directly to heat within a few nanoseconds (Milne et al., 1987). A certain fraction of the initially-formed excited state ^1DOM undergoes intersystem crossing to the longer-lived ^3DOM state (Zepp et al., 1985; Haag et al., 1984b). Essentially all of the ^3DOM is quenched by oxygen (Zepp et al., 1985); most of these quenching acts probably yield $^1\text{O}_2$, which, in turn, mostly decays by heating the water. The fraction of quenching acts leading to $^1\text{O}_2$ has been reported to be as low as 27% for some types of organic triplets, such as porphyrins and aromatic ketones; the remaining quenching acts are believed to result in the formation of biradicals or trioxetanes (Gorman and Rodgers, 1986):

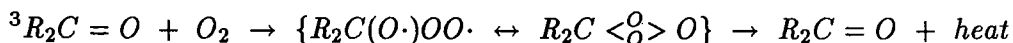

which mostly decompose back to ground state starting materials. Because the fraction of quenching acts leading to $^1\text{O}_2$ is higher for many other organic sensitizers (Gorman and Rodgers, 1986; Gorman et al., 1978), we expect the quantum yield of intersystem crossing in DOM to be less than four times the quantum yield (1-3%) of $^1\text{O}_2$ formation.

A small fraction of ^3DOM transfers an electron to oxygen to produce O_2^- , which decays by disproportionation to H_2O_2 and by some unknown reactions (Petasne and Zika, 1987). A minute fraction of excited state DOM ejects an electron (Fischer et al., 1985; Zepp et al., 1987b), which reacts rapidly with dissolved oxygen or with nitrate when present at >3 ppm NO_3^- -N (Buxton et al., 1988). Although the primary quantum yield for electron ejection is high (0.005-0.008), at most a few percent of ejected electrons escape the cage and

Table 6.4.1: Kinetic and Concentration Data for Transients in Surface Water

Transient	Sources	Sinks ^a	k_{sink}^b	Formation Rate, M·s ⁻¹	Loss Rate, s ⁻¹	Midday, surface Concentration, M
³ DOM	DOM	$k_q[\text{O}_2]$	$2 \times 10^9 \text{M}^{-1} \text{s}^{-1}$ [1]	$(3-300) \times 10^{-9}$	5×10^5	$(1-5) \times 10^{-13} \text{c}$ [1]
¹ O ₂	DOM	$k_q(\text{H}_2\text{O})$	$2.5 \times 10^5 \text{s}^{-1}$ [2]	$(3-300) \times 10^{-9}$	2.5×10^5	$10^{-14} - 10^{-13} \text{d}$ [1,3] $10^{-14} - 10^{-12} \text{e}$
ROO·	DOM	$k_t[\text{ROO}·]^2 ?$ $k_r[\text{DOM}]$? ?	$10^{-11} - 10^{-10}$	0.1-1 ?	$10^{-11} - 10^{-10} \text{e}$ [4]
HO·	DOM ^e NO ₃ ⁻ NO ₂ ⁻	$k_t[\text{Br}_2^-]^d$ $k_r[\text{DOM}]^e$	$1.3 \times 10^9 \text{M}^{-1} \text{s}^{-1} \text{d}$ [5] $2.5 \times 10^4 \text{L mg}^{-1} \text{s}^{-1} \text{c}$ [7]	$(3-300) \times 10^{-12} \text{d}$ $10^{-11} - 10^{10} \text{e}$	10^{6}d $(0.2-2) \times 10^{5} \text{e}$	$10^{-18} - 10^{-17} \text{d}$ [6] $(2-6) \times 10^{-16} \text{e}$ [7]
e_{aq}^-	DOM	$k_r[\text{O}_2]$ $k_r[\text{NO}_3^-]$	$2 \times 10^{10} \text{M}^{-1} \text{s}^{-1}$ [5] $1 \times 10^{10} \text{M}^{-1} \text{s}^{-1}$ [5]	$(5-10) \times 10^{-11}$	$(0.5-1.5) \times 10^7$	$(1-2) \times 10^{-17} \text{e}$ [8]
O ₂ ⁻	DOM	$k_t[\text{O}_2^-]^2$ $k_r[\text{DOM}]$	$6 \times 10^{12} [\text{H}^+] \text{M}^{-1} \text{s}^{-1}$ [9] ?	$10^{-11} - 10^{-7} ?$	$10^{-3} - 1 ?$	$10^{-9} - 10^{-8} ?$ [10]
CO ₃ ⁻	HO· Br ₂ ⁻ ?	$k_r[\text{DOM}]$	$40 \text{L mg}^{-1} \text{s}^{-1}$ [11]	$10^{-11} - 10^{-10} \text{e}$	20-1000 ^e	$10^{-14} - 10^{-13} \text{e}$ [11]
Br ₂ ⁻	HO·	k_r^f	$2.5 \times 10^3 \text{s}^{-1}$ [12]	$(3-30) \times 10^{-12} \text{d}$	$2.5 \times 10^{3} \text{d}$	$10^{-15} - 10^{-14} \text{d}$ [6,12]

^aThe species in brackets or parentheses indicate the interactant, and the rate constant subscript indicates the type of interaction: q = energy transfer (quenching), t = termination of two radicals, r = other reactions.

^bValue of rate constants in previous column.

^c>90 kJ/mol

^dSeawater.

^eFreshwater.

^fConsumption of Br₂⁻ in seawater appears to involve reaction with various carbonate species including CO₃²⁻, MgCO₃, NaCO₃, and CaCO₃, but the expected product CO₃⁻ has not been confirmed [12].

References Cited in Table (numbers in brackets above)

- 1 Zepp et al. (1985)
- 2 Rodgers and Snowden, (1982)
- 3 Haag and Hoigné, (1986)
- 4 Faust and Hoigné (1987)
- 5 Buxton et al. (1988)
- 6 Mopper and Zhou (1989)
- 7 Haag and Hoigné (1985)
- 8 Zepp et al. (1987)
- 9 Bielski et al. (1985)
- 10 Petasne and Zika (1987)
- 11 Larson and Zepp (1988)
- 12 Zafiriou et al. (1987)

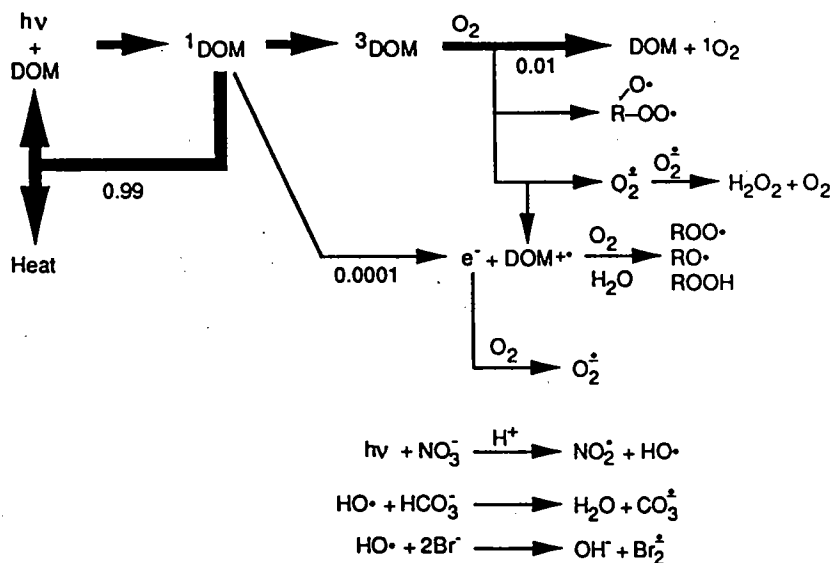

RA-M-320522-205

Figure 6.4.1: Photochemical pathways for transient formation in surface waters.

therefore the effective yield and steady state concentrations are low (Zepp et al., 1987b). The pathway $e_{aq}^- \rightarrow \text{O}_2^{\cdot-} \rightarrow \text{H}_2\text{O}_2$ does not account for a significant portion of the observed H_2O_2 accumulation ($0.001\text{--}2.0 \text{ nM}\cdot\text{s}^{-1}$) (Cooper et al., 1988) because electron scavengers do not inhibit H_2O_2 production (Zepp et al., 1987b). Also, e^- or H-atom abstraction by ${}^1\text{O}_2$ is negligible because subjecting freshwater DOM to high doses of ${}^1\text{O}_2$ using dyes at $\lambda > 500 \text{ nm}$ does not yield significant amounts of H_2O_2 (Sturzenegger et al., 1984). We therefore suggest that $\text{O}_2^{\cdot-}$ and H_2O_2 result primarily from direct e^- transfer from ${}^3\text{DOM}$ to O_2 . The radical cation formed by electron ejection or transfer may react with oxygen to form peroxy radicals or $\text{HO}_2\cdot$, thus contributing to the radical pool.

$\text{HO}\cdot$ radicals appear to be formed mostly by photolysis of nitrate or nitrite (Haag and Hoigné, 1985; Russi et al., 1982; Zepp et al., 1987a) in freshwater and from DOM in seawater, the latter based on correlation of $\text{HO}\cdot$ yields with DOM fluorescence and higher yields than could be explained by $\text{NO}_2^-/\text{NO}_3^-$ photolysis (Mopper and Zhou, 1989). It is now well accepted that photolysis of H_2O_2 generates insignificant amounts of $\text{HO}\cdot$ compared to other sources (Haag and Hoigné, 1985) because of the low concentration and light absorption rate of H_2O_2 . $\text{HO}\cdot$ is consumed by reaction with DOM in freshwater (Haag and Hoigné, 1985; Zepp et al., 1987a) and bromide ion in seawater (Zafiriou et al., 1987).

Secondary radicals form by reaction of primary radicals with solutes. $\text{HO}\cdot$ oxidizes HCO_3^- to $\text{CO}_3^{\cdot-}$ either directly (freshwater) (Larson and Zepp, 1988) or via $\text{Br}_2^{\cdot-}$ and $\text{BrCO}_3^{\cdot-}$ (seawater) (Zafiriou et al., 1987). $\text{HO}\cdot$ and $\text{CO}_3^{\cdot-}$ almost certainly oxidize DOM to phenoxy and peroxy radicals; the latter will in turn cleave $\text{HO}_2\cdot/\text{O}_2^{\cdot-}$ if they are derived from an aromatic ring or are α to a hydroxy group. Thus, a cascade of radicals results, each usually less reactive than the precursor. The ultimate fate of odd-electron species depends on the

decay modes of the least reactive radicals, which include disproportionation of $\text{HO}_2\cdot/\text{O}_2^-$ to H_2O_2 , Russell termination of peroxy radicals to alcohols and ketones, dimerization of phenolate radicals and cross termination of different radicals.

Two approaches have been used to measure transient concentrations. The first involves measuring the first-order rate constant k_{exp} for loss of a selective trapping agent A, added in low enough concentration that it traps only a small fraction of the transient of interest. Under these conditions:

$$-d[A]/dt = k_r[T] - ss[A] = k_{exp}[A]$$

$$[T]_{ss} = k_{exp}/k_r$$

where $[T]_{ss}$ is the steady-state transient concentration and k_r is the known second-order rate constant for reaction of A with T. In the second method, A is added in high enough concentration to trap all of the transient as it is formed, and the zero-order rate of product formation or reactant loss is measured:

$$-d[A]/dt = +d[Product]/dt = k'_{exp}$$

$$[T]_{ss} = k'_{exp}/k_d$$

where k_d is the first-order transient loss rate constant in the absence of A.

The data in Table 6.4.1 include only values measured or estimated thus far and therefore they do not necessarily represent all types of waters. The steady state concentrations are usually summer, noon, surface values and the yearly averages in the entire photic zone are an order of magnitude or more lower. The data are of widely varying accuracy. For example, the formation and loss rates of $^1\text{O}_2$ are fairly well known, but the corresponding rates for $\text{ROO}\cdot$ and O_2^- are crude estimates. The values for e_{aq}^- , $\text{HO}\cdot$, and ^3DOM appear to be reliable, but there are less data available than for $^1\text{O}_2$ from which to judge the accuracy and/or the range of values occurring under a broad variety of conditions. It may be assumed (Zepp et al., 1985), however, that in well-oxygenated waters

$$[^3\text{DOM}]_{ss} = 0.5[^1\text{O}_2]_{ss}$$

and therefore many more $[^3\text{DOM}]_{ss}$ measurements were inherently performed by $[^1\text{O}_2]_{ss}$ measurements. We should note that the oft-quoted $[\text{HO}\cdot]_{ss}$ for freshwaters reported by Mill et al. (1980) of 10^{-17} M is too low by a factor of 2 to 5 because the relatively high concentration of the cumene used as a trap repressed the steady-state $\text{HO}\cdot$ concentration. The low loss rate of O_2^- hampers measurement of its concentration by the first-order method because of difficulty in finding a selective trap that does not repress the steady state.

There is always some uncertainty as to the identity of the transients being measured. It is inherently difficult to study radicals like $\text{ROO}\cdot$ which contain DOM groups because the variety of DOM structures means that a whole class of radicals are formed. The concentration of $\text{ROO}\cdot$ was estimated by the first-order method using $k_r = 10^5 \text{M}^{-1}\text{s}^{-1}$ for the phenolic traps used, but if the radicals are assigned a reactivity that is an order of magnitude lower, then the calculated steady-state concentration will be correspondingly higher. A similar difficulty could arise with $^1\text{O}_2$ because it has recently been shown that traditional $^1\text{O}_2$ traps such as furans can also be susceptible to radical oxidation (Haag and Mill, 1987).

Quantifying reaction products is a useful way of testing trap selectivity, but sometimes products from two transients are so similar that this is not possible. Kinetics selectivity tests include (1) comparing relative rates of reaction of two trapping agents with their known relative reactivities with the transient of interest and (2) adding lifetime modifiers which selectively alter the concentration of the transient or possible interferents in a quantifiable way. Lifetime modifiers used in this way have been summarized (Haag, 1988).

Other potential transients that have received little attention are worthy of further study. The biradicals or trioxetanes discussed above (Gorman and Rodgers, 1986) may contribute to the radical pool or act as a reservoir for $^1\text{O}_2$. Zepp et al. (1987) have shown that freshwater algae can catalyze the photo-oxidation of anilines in the presence of H_2O_2 , by an unknown mechanism. The photolysis of nitrate has been examined mostly from the point of view of $\text{HO}\cdot$ production; however, an equivalent amount of NO_2 must be formed and this has been shown to nitrate phenols in natural waters (Niessen et al., 1988). Relatively few studies have dealt with the photochemical reactions of transition metals and semiconductors; however, these appear to be minor sources of free radicals. The effect of aggregation or sorption to particulate matter on the rates of interaction with reactive transients is also an area deserving of further attention because the higher concentrations of compounds in such micro-environments may alter pathways and efficiencies from those observed in bulk solution.

The effect of increased ultraviolet light due to stratospheric ozone depletion will increase the concentration of transient reactants for several reasons. First, because formation rates are proportional to light intensity, an increased light flux will increase production. Second, because the quantum yield of formation increases with decreasing wavelength (Zepp et al., 1985; Haag et al., 1984b; Fischer et al., 1985; Cooper et al., 1988), the efficiency of production will be increased. Thirdly, because DOM absorbs light more strongly the lower the wavelength, sunlight will be absorbed in a shorter path and the oxidants will be concentrated closer to the surface. For example, we estimate that if current solar intensities are shifted 30 nm to the blue, the generation of $^1\text{O}_2$ and oxyradicals will nearly double. Rates of oxidative transformation of solutes will increase proportionately.

References

- Baxter, R.M. and J.H. Carey (1982). *Freshwater Biol.*, **12**: 211-217.
- Bielski, B.H.J., D.R. Cabelli, R.L. Arudi and A.B. Ross (1985). *J. Phys. Chem. Ref. Data*, **14**: 1941-1100.
- Buxton, G.V., C.L. Greenstock, W.P. Helman and A.B. Ross (1988). *J. Phys. Chem. Ref. Data*, **17**: 513-886.
- Cooper, W.J., R.G. Zika, R.G. Petasne and A.M. Fischer (1988). In: *Influence of Equatic Humic Substances on Fate and Treatment of Pollutants*, P. MacCarthy and I.H. Suffet (eds.), ACS Symposium Series, Washington, D.C.
- Faust, B.C. and J. Hoigné (1987). *Environ. Sci. Technol.*, **21**: 957-964.
- Fischer, A.M., D.S. Kligler, J.S. Winterle and T. Mill (1985). *Chemosphere*, **14**: 1299-1306.

- Gorman, A.A. and M.A.J. Rodgers (1986). *J. Am. Chem. Soc.*, **108**: 5074–5078.
- Gorman, A.A., G. Lovering and M.A.J. Rodgers (1978). *J. Am. Chem. Soc.*, **100**: 4527–4532.
- Haag, W.R. (1988). *J. Res. Nat. Bur. Standards*, **93**(3): 285–288.
- Haag, W.R. and J. Hoigné (1985). *Chemosphere*, **14**: 1659–1671.
- Haag, W.R. and J. Hoigné (1986). *Environ. Sci. Technol.*, **20**: 341–348.
- Haag, W.R. and T. Mill (1987). *Am. Chem. Soc., Div. Environ. Chem.*, **27**(1): 616–619 (Abstract).
- Haag, W.R., J. Hoigné, E. Gassmann and A.M. Braun (1984a). *Chemosphere*, **13**: 631–640.
- Haag, W.R., J. Hoigné, E. Gassmann and A.M. Braun (1984b). *Chemosphere*, **13**: 641–650.
- Larson, R.A., L.L. Hunt and D.W. Blankenship (1977). *Environ. Sci. Technol.*, **21**: 492.
- Mill, T., W.R. Haag and D. Karentz (1989). Estimated effects of indirect photolysis on marine organisms. (This workshop).
- Mill, T., D.G. Hendry and H. Richardson (1980). *Science*, **207**: 886–887.
- Milne, P.J., D.S. Odum and R.G. Zika (1987). In: *Photochemistry of Environmental Aquatic Systems*, R.G. Zika and W.J. Cooper (eds.), ACS Symposium Series 327, Washington, D.C., Chapter 10.
- Mopper, K. and X. Zhou (1989). (submitted).
- Niessen, R., D. Lenoir and P. Boule (1988). *Chemosphere*, **17**: 1977–1984.
- Petasne, R.G. and R.G. Zika (1987). *Nature*, **325**: 516–518.
- Rodgers, M.A.J. and P.J. Snowden (1982). *J. Am. Chem. Soc.*, **104**: 5541–5543.
- Ross, R.D. and D.G. Crosby (1985). *Environ. Toxicol. Chem.*, **4**: 773–778.
- Russi, H., D. Kotzias and F. Korte (1982). *Chemosphere*, **11**: 1041–1048.
- Sturzenegger, V. W.R. Haag and J. Hoigné (1984). (unpublished).
- Zafiriou, O.C., M.B. True and E. Hayon (1987). In: *Photochemistry of Environmental Aquatic Systems*, R.G. Zika and W.J. Cooper (eds.), ACS Symposium Series 327, Washington, D.C., Chapters 7 and 8.
- Zepp, R.G., J. Hoigné and H. Bader (1987). *Environ. Sci. Technol.*, **21**: 443–450.
- Zepp, R.G., A.M. Braun, J. Hoigné and J.A. Leenheer (1987). *Environ. Sci. Technol.*, **21**: 485–490.

Zepp, R.G., P.F. Schlotzhauer and R.M. Sink (1985). *Environ. Sci. Technol.*, **19**: 74-81.

Zepp, R.G., Y.I. Skurlatov and J.T. Pierce (1987). In: *Photochemistry of Environmental Aquatic Systems*, R.G. Zika and W.J. Cooper (eds.), ACS Symposium Series 327, Washington, D.C., Chapter 16.

6.5 Estimated Effects of Indirect Photolysis on Marine Organisms

Theodore Mill¹, Werner Haag¹ and Deneb Karentz²

¹Chemistry Laboratory
SRI International
Menlo Park, California 94025

²Laboratory of Radiobiology and Environmental Health
University of California
San Francisco, California

Introduction

Recent measurements at McMurdo Sound confirm the long-expected increase in solar UV radiation at short wavelengths predicted from decreases in stratospheric ozone in the Antarctic (Lubin and Frederick, 1989). Increases of as much as 15 percent in short wavelength light were found during the October to December 1988 measurement period. This increase in the high energy solar photon flux is certain to change several kinds of photo-processes in marine and fresh water systems, including direct photolysis of chemical species and organisms, and indirect photoeffects caused by formation and reaction of transient oxidants in the insolated water column (Haag and Mill, 1989). And while there is an abundant literature on direct photobiological effects of solar radiation on marine organisms (Calkins, 1982; Polne and Gibor, 1982; Dunlap and Chalker, 1986), there is only speculation about possible indirect photobiological effects (Baxter and Carey, 1982; Zepp et al., 1987). This paper proposes a plausible model for indirect photobiology and uses it to evaluate possible effects of photooxidants on plankton cells.

Phototransients

In a separate paper, we summarize what is known of the origins, sinks, and concentrations of the transient oxidants formed in insolated surface waters (Haag and Mill, 1989). These oxidants include a variety of oxyradicals (such as HO, RO, RO₂, =C-O, O₂⁻, CO₃⁻) as well as singlet oxygen, and any increase on UVB irradiance because of ozone depletion will cause an increase in the concentrations of these oxidants. HO radical has the greatest potential for biological effects because of its high reactivity towards most kinds of organic structures. However the HO steady state concentration([HO]_{ss}) is extremely low in most surface waters (< 10⁻¹⁵M) making other, less reactive oxyradicals plausible oxidants for some biological systems (Farhatziz and Ross, 1977; Mill, 1989). Singlet oxygen is unlikely to have a significant role as an indirect oxidant for biological systems because of its low steady-state concentration and high selectivity, although its role in direct photobiological effects is well known (Spikes, 1977).

Biological Species in Marine Surface Waters

Estimates of the ratio of abiotic to biotic carbon at about 4:1 in surface waters (Parsons and Takahashi, 1972) together with Mopper and Zhou's (1989) observations that [HO]_{ss} is unaffected by prior filtration of marine water through a 0.2 μ filter make it almost certain

that the steady state concentrations of oxidants in surface waters are controlled almost entirely by abiotic dissolved organic matter (DOM). Because cell walls will be the first targets for interaction with externally formed transient oxidants, their organic content will determine whether an interaction will lead to an oxidative change; calcareous and siliceous materials are effectively inert to oxidants.

Plankton can be divided into bacteria, photosynthetic algae (phytoplankton) and various consumers (zooplankton). Recent discovery of high populations of viruses of $< 0.1 \mu\text{m}$ in some surface waters (Bergh et al., 1989) suggests that a broad range of biological sizes and types can be found in many natural waters (Kennish, 1985). Bacterioplankton have the same physical and morphological features as other bacterial cells and range in size up to several μm . The protoplast is encased in a rigid cell wall composed of peptidoglycan. Phytoplankton cells are generally larger, up to several hundred μm , and have an outer protective covering surrounding the phospholipid bilayer that may be mucilaginous (blue-greens), cellulosic (green algae and dinoflagellates) (Newell and Newell, 1973) or formed by mineralization (silica for diatoms, calcium for coccolithophorids Darley, 1974).

Zooplankton species span a much larger size spectrum than phytoplankton, ranging from several μm to cm or larger. Zooplankton communities are made up of organisms such as unicellular protists, multicellular ciliates, a diverse assortment of invertebrates, gelatinous organisms (like salps and jellyfish) and fish eggs and larvae. These primary and secondary consumers also have protective outer coverings made of mineralized layers, protein, or chitin, a modified polysaccharide (Newell and Newell, 1973).

To model the effect of oxidative transients on biological species, we have chosen a generic $2 \mu\text{m}$ organism with a population of 10^4 cells mL^{-1} and with an organic protein, polysaccharide, or lipid wall, any of which may be susceptible to reaction with HO or possible Br_2^- , a radical derived from HO in marine waters.

Light Absorbing Properties of Surface Waters and Phytoplankton

Treatment of light penetration and absorption in a water column is fully described elsewhere (Zepp and Cline, 1978; Baker et al., 1980; Leifer, 1988); solar irradiance is a function of cloud cover and sun angle and thus varies with latitude, season and time of day. Absorption of light in the water column by dissolved species follows Beer's law:

$$I_A = I_0(1 - 10^{\alpha l}) \quad (6)$$

where I_A and I_0 are absorbed and incident light fluxes, α is the absorption cross section of DOM in water in cm^{-1} and l is the pathlength in cm. Typical coastal marine surface waters have values of α of 0.01 to 0.02 cm^{-1} near 300 nm, whereas *E. coli*, reported to have an α of 1200 cm^{-1} at 254 nm (Jagger, 1977), will have an α of about 40 cm^{-1} at 300 nm. From these values and the population of 10^4 2 mm organisms mL^{-1} , we estimate that about 6000 times as much light is absorbed by the DOM as by the organisms. For 200 μm organisms with the same optical properties and cell count, DOM will absorb only ten times as much light at 300 nm.

Rate of Oxidation of Plankton Cell Walls

The upper rate of interaction of the homogeneously produced photooxidants and organism cell walls is given by a relation for estimating the interaction rate of a dissolved species with a small particle in a non-turbulent fluid medium (Rose, 1960) in collisions cm^{-2} of surface time $^{-1}$.

$$\text{Rate} = D[\text{HO}]/r \quad (7)$$

The rate organism $^{-1}$ of surface area A is

$$\text{Rate organism}^{-1} = 4\pi r D[\text{HO}] \quad (8)$$

where D is the diffusion coefficient for HO in water, r is the radius of the particle, and [HO] is the molecular concentration. Substituting values for $D = 2 \times 10^{-5} \text{ cm}^2 \text{ s}^{-1}$, $r = 1 \times 10^{-4} \text{ cm}$, and $[\text{HO}]_{ss}$ of $6000 \text{ molec cm}^{-3}$ ($1 \times 10^{-17} \text{ M}$) (Mopper and Zhou, 1989), gives a rate of ~ 10 collisions organism $^{-1} \text{ s}^{-1}$. The collision rate for a $200 \mu\text{m}$ organism is ~ 1000 collisions s^{-1} organism $^{-1}$. This calculation shows that HO collision rates are low, but still significant.

For example, the maximum fractional rate of oxidation of molecules in the surface layer of an organism can be estimated by first assuming that one out of ten collisions of HO with the surface results in oxidation, a reasonable assumption, given the high reactivity of HO toward most organic structures (Farhatziz and Ross, 1977). The calculation further requires an estimate of the number of surface molecules on a particular-sized organism. For cellulose- or protein walls, glucose- or alanine-like units have an average molecular surface area of $\sim 0.3 \text{ nm}^2$ (Leffler and Zupancic, 1980). Thus a $2 \mu\text{m}$ organism has $\sim 4 \times 10^7$ glucose units on the outer cellulose wall surface. With a collision rate per organism of 10 s^{-1} , oxidation of 10 percent of the surface would require about 50 days. For comparison, a $200 \mu\text{m}$ organism would have 4×10^{11} glucose or glycine groups on the surface, but because of the higher collision rate, the same fraction of surface organic units will oxidize per unit time.

Most HO react with Br^- or CO_3^{2-} in surface waters to form Br and CO_3^- which are less reactive, but have much higher steady state concentrations and thus higher collision rates with plankton cells. For example, we estimate that $[\text{CO}_3^-]_{ss}$ is five orders of magnitude larger than $[\text{HO}]_{ss}$. Even if reactive collision rates are much smaller than for HO, secondary species like CO_3^- also may play an important role in the photobiology of these systems. Moreover, at low rates of collision of radicals with particles, the possibility exists that radical processes may begin to resemble those found in emulsion polymerization where particles with odd numbers of radicals react rapidly because of slow rates of termination (Walling, 1957).

Conclusions

Estimates of relative light absorption by plankton and DOM and rates of HO interaction and oxidation of cell wall constituents suggest a possible role for indirect photooxidation in the observed effects of UV light on aquatic organisms. The simple model developed here ignores a variety of complications associated with biological surface interactions, such as exogenous radical scavengers, unreactive inorganic constituents in the wall, unknown

efficiencies of oxidation of the organic constituents and the physiological effects of oxidizing the outermost layer of cell wall.

Depletion of the upper ozone layer will increase the importance of indirect photobiology by increasing the flux of HO and other photooxidants. Wavelength dependence data for the quantum yield for singlet oxygen production suggests that all of the oxidant production rates will increase substantially with an increase in the solar flux below 300 nm (Haag and Mill, 1989).

References

- Baker, K.S., R.C. Smith and A.E.S. Green (1980). *Photochemn. Photobiol.*, **32**: 367-374.
- Baxter, R.M. and J.H. Carey (1982). *Freshwater Biol.*, **12**: 285-292.
- Bergh, O., K.Y. Borsheim, G. Bratbak and M. Heldal (1989). *Nature*, **340**: 467-468.
- Bird, R.B. (1960). *Transport Phenomena*, John Wiley and Sons, New York, p. 647.
- Calkins, J. and J.R. Thordardottir (1982). In: *The Role of Solar Ultraviolet Radiation in Marine Ecosystems*, J. Calkins (ed.), NATO Conf. Ser. IV Mar. Sci., Vol. 7, pp. 247-261.
- Darley, W.M. (1974). Silicification and calcification. In: *Algal Physiology and Biochemistry*, W.D.P. Steward (ed.), Botanical Monograph 10, Univ. Calif. Press, Berkeley, pp. 655-675.
- Dunlap, W.C., B.C. Chalker and J.K. Oliver (1986). *J. Exp. Mar. Ecol.*, **104**: 1-10.
- Farhatziz, and A.B. Ross (1977). *Selected Specific Rates of Reaction of Transients in Aqueous Solution*, NSRDS-NBS 59, Washington, D.C.
- Haag, W.R. and T. Mill (1989). Survey of sunlight induced transient species in surface waters. (This workshop).
- Jagger, J. (1977). In: *The Science of Photobiology*, K.C. Smith (ed.), Plenum Publishing Corp, New York, p. 21.
- Kennish, M.J. (1989). *Practical Handbook of Marine Science*, CRC Press, Boca Raton, Florida.
- Leffler, J.E.W. and J.J. Zupancic (1980). *J. Amer. Chem. Soc.*, **1102**: 259-264.
- Leifer, A. (1988). *The Kinetics of Environmental Aquatic Photochemistry*, Amer. Chemical Society, Washington, D.C.
- Lubin, D. and J. Frederick (1989). *Geophys. Res. Lett.*, **16**: 783-785.
- Mill, T. (1989). *Environ. Toxicol. Chem.*, **8**: 31-43.
- Mopper, K. and X. Zhou (1989). (Submitted manuscript.)

Newell, G.E. and R.C. Newell (1963). *Marine Plankton*, Hutchinson Educational Ltd., London.

Parsons, T. and M. Takahashi (1973). *Biological Oceanographic Processes*, Pergamon Press, Inc. Elmsford, New York, p. 38.

Polne, M. and A. Gibor (1982). In: *The Role of Solar Ultraviolet Radiation in Marine Ecosystems*, J. Calkins (ed.), NATO Conf. Ser. IV, Mar. Sci. Vol. 7, pp. 573-579.

Spike, J.J. (1977). In: *The Science of Photobiology*, K.C. Smith (ed.), Plenum Publishing Corp, New York, pp. 87-109.

Walling, C. (1957). *Free Radicals in Solution*, John Wiley and Sons, New York, p. 273.

Zepp, R.G. and D.M. Cline (1977). *Environ. Sci. Technol.*, 11: 359-363.

Zepp, R.G., Y.I. Skurlatov and J.T. Pierce (1987). *Amer. Chem. Soc. Symp. Ser. 327*, pp. 215-224.

6.6 Photoreduction of Chromium in Natural Waters

George R. Helz and Robert J. Kieber, Jr.
Chemistry and Biochemistry Department
University of Maryland
College Park, Maryland 20742

Hexavalent Cr (CrO_4^{2-} plus HCrO_4^-) is a toxic component associated with various industrial wastes, especially those from tanning and metal plating. It is extremely persistent and mobile in nature. Transport over kilometer distances in groundwater has been documented. Reduction of Cr is a detoxifying process because the trivalent form is readily sorbed or precipitated by hydrolysis. Cr(III) is comparatively inaccessible to cells. However, reduction is thermodynamically unfavored in oxygenated waters. It therefore can not occur without expenditure of external energy. Investigation of diurnal variations in the Cr(VI)/Cr(III) ratio in Back River, a sewage effluent contaminated tributary of Chesapeake Bay, has revealed a cycle in which minimum values are encountered shortly after midday. Although the variation in Cr(VI)/Cr(III) with time is somewhat erratic, owing to heterogeneity in the estuary, the fluctuations inversely track fluctuations in H_2O_2 , a photochemical product. When unfiltered samples of the estuarine water are placed in quartz flasks, reduction of Cr(VI) can be produced by exposing the flasks to sunlight, while no reduction is observed in dark controls. Similarly, no reduction is observed if the samples are filtered before exposure to sunlight. Several mechanisms can be proposed to account for the reduction part of this cycle. Our evidence favors a process involving photoreduction of colloidal and particulate ferric iron followed by a rapid direct reaction between Fe^{2+} and Cr(VI). Other reductants may be involved in subsequent steps. We have not studied the nature of the oxidation part of the cycle. Published information suggests that particulate and colloidal Mn may be involved. Light driven reduction of stable Cr(VI) species may account for the relatively short mean residence time of Cr in the ocean ($10^3 - 10^5$ y). In addition to light, the process will be limited by the supply of particulate and colloidal Fe and of organic matter, which is a participant in the photoreduction of iron. Small concentrations of both iron and organic matter in the ocean suggest that removal of Cr will be primarily a coastal and estuarine phenomenon. The oceanic and estuarine distribution of Cr is consistent with this inference. The recent suggestion that Fe concentrations may have been greater in the ocean during the Pleistocene imply that Cr removal from the ocean may be been more efficient at that time.

References

- Beattie, J.K. and G.P. Haight, Jr. (1972). Chromium (VI) oxidations of inorganic substances. In: *Inorganic Reaction Mechanisms, Part II Progress in Inorganic Chemistry*, Interscience, New York, Vol. 17, pp. 939-145.
- Campbell, J.A. and P.A. Yeats (1984). Dissolved chromium in the St. Lawrence Estuary. *Est. Coast. Mar. Sci.*, **19**: 513-522.

- Kieber, J.R., Jr. (1987). *The Effect of Sunlight on the Chemistry of Hydrogen Peroxide and Chromium in Natural Waters*, unpublished Ph.D. Thesis, University of Maryland, College Park.
- Murray, J.W., B. Spell and B. Paul (1981). The contrasting geochemistry of manganese and chromium in the eastern tropical Pacific Ocean. In: *Trace Metals in Sea Water*, C.S. Wong, E. Boyle, K.W. Bruland, J.D. Burton and E.D. Goldberg (eds.), Plenum Press, New York, pp. 643-669.
- Van der Weijden, C.H. and M. Reith (1982). Chromium (III)-chromium (VI) interconversions in seawater. *Mar. Chem.*, 11: 565-572.

6.7 Effects of Solar UV-radiation on Hydrogen Peroxide Content and Radical Self-purification Processes in Surface Natural Waters

**Y. Skurlatov
Institute of Chemical Physics
Academy of Sciences, U.S.S.R**

In the natural waters hydrogen peroxide is formed by sunlight as a result of photolysis of the abiotic components of water media and algae cells. The contributions of this channel are compared. In both the solar UV-radiation effective and the precursor of hydrogen peroxide is superoxide-radical.

Damage of algae cells arises under UV-radiation as a consequence of internal cellular OH-radical formation. In the external media OH can play an important role for self-purification of water. A quantitative estimate of this role may be obtained by measuring the rate of radical formation and the "inhibitory capacity" of the media. Under excessive intensity of the free-radical processes the formation of superoxidative state is possible in natural water, that can be characterized by presence of particles carrying very reactive oxidative equivalents, presumably microcolloidal Mn (III, IV).

For example Lake Baikal has shown that OH-radical can be formed as a result of collapsic phenomena that can be accompanied self-lighting of water media. UV-radiation has a big effect on this phenomena.

Hydrogen peroxide has more toxic impact on the photosynthesis of blue-green algae compared with green algae. The blue-greens excrete outside reductive substances that effectively interact with hydrogen peroxide. If the rate of hydrogen peroxide formation becomes less than that of reductive substances, the quasi-reductive state forms in a water media.

The toxic effects of superoxidative and quasi-reductive states on water ecosystems are discussed.

7 UV Effects on Heterogeneous Chemical Processes

7.1 Photoprocesses Involving Colloidal Iron and Manganese Oxides in Aquatic Environments

T. David Waite

Australian Nuclear Science & Technology Organisation
Lucas Heights Research Laboratories
New Illawarra Road
Lucas Heights, New South Wales
Australia

Background

Oxide/hydroxide minerals of Mn(III,IV) and Fe(III) are thermodynamically stable under most oxygenated natural water conditions and typically exhibit high surface areas (particularly if in colloidal form). As such, these minerals are ideal loci for sorption of a wide range of water constituents including potentially troublesome species such as trace metals and organic compounds. Changes in oxidation state dramatically alter the solubility of these oxides with consequent implications for the fate of any adsorbed species.

In addition to the implications for the fate of adsorbed toxic or troublesome species, such changes in the solubility of iron and manganese may have a significant effect on the biota for which these metal ions are essential nutrients but, typically, unavailable in their particulate form. Indeed, Anderson and Morel (1983), Finden et al.(1984), Sunda et al.(1983) and Sunda (1988) note that iron or manganese may limit algal productivity in some situations and speculate that in such cases, enhancement of limiting nutrient supply through reduction processes may significantly alter algal growth rate, primary productivity, and species distribution. Field evidence that iron or manganese are limiting nutrients in some situations has been provided by Brand et al.(1983), Entsch et al.(1983), Martin and Gordon (1988), and Martin and Fitzwater (1988).

Investigations in Natural Systems

Various field and laboratory studies over the last five years have indicated that solar radiation may induce or enhance the reductive dissolution of iron and manganese oxides/hydroxides in oxygenated natural waters. Collienne (1983) and McKnight et al.(1988a, 1988b) present convincing evidence for a sunlight-driven diurnal cycling in Fe(II) concentration in acidic streams and lakes which involves a concomitant dissolution of solid iron oxide/hydroxide. Sunda et al.(1983) have shown that light enhances the dissolution of an amorphous manganese oxide in seawater and have suggested that this process accounts for the surface maxima in dissolved manganese observed in the oceans. Hong and Kester (1986) have found some evidence of a similar light induced generation of reduced iron in waters off Peru.

In most of the cases cited above, the presence of natural organic materials was shown to be critical to the occurrence of photo-dissolution. That naturally occurring organic compounds are capable of inducing or assisting the photo-dissolution of iron and manganese

oxides has been confirmed in a number of laboratory studies using humic and fulvic acids extracted from fresh and marine waters (Waite and Morel, 1984a; Sunda et al., 1983; Waite et al., 1988).

Model Studies

Considerable insight into the possible mechanisms of photo-dissolution of metal oxides/hydroxides in natural waters may be gleaned from the results of studies in simple, well-defined systems. Thus, photolysis of γ -FeOOH in the presence of the strong Fe(III) complexing agent citric acid results in dissolution phenomenon qualitatively similar to that observed in the presence of fulvic acid (Waite and Morel, 1984b). Three alternative mechanisms for the preliminary photochemical process were proposed in this case: (a) a photo-Kollbe process in which photo-generated holes are scavenged by readily oxidizable species such as the ROO⁻ groups and the remaining electrons reduce the colloidal substrate (a semiconductor mechanism); (b) photo-degradation of surface-located Fe(III)-OH groups, assisted by OH scavenging by citrate; and (c) a ligand to metal charge transfer (LMCT) process within surface-located Fe(III)-citrate groups resulting in oxidation of the ligand and the reduction of the Fe(III) metal center (a process equivalent to the well-documented homogeneous photolysis of ferric citrate). Mechanism (b) was discarded because the surface-located Fe(III) hydroxo groups have been reported to absorb at considerably higher energy than that of the irradiating light used, but both (a) and (c) remain possibilities. All iron oxides/hydroxides absorb strongly in the near-UV region (Sherman and Waite, 1985) thus excitation by solar radiation may generate electron-hole pairs by promotion of an electron from the valence to the conduction band. Although e^- - h^+ pair recombination appears to be rapid in iron oxides (Stramel and Thomas, 1986; Leland and Bard, 1987), hole-transfer to sorbed species should be fast enough to ensure that some degree of oxidation takes place at the oxide surface. Electrons remaining at the surface after removal of holes have been shown to possess lifetimes of the order of milliseconds (Frese and Kennedy, 1983) and may reduce sorbed oxygen or may reductively dissolve the solid.

The photo-oxidation of oxalate, sulfite, and iodide by iron oxides with concomitant release of Fe(II) has been described by Leland and Bard (1987) in terms of a semiconductor mechanism although differences in the rates of photo-oxidation between the various iron oxide phases appeared to be due to intrinsic differences in crystal and surface structure rather than differences in surface area or band gap. Faust and Hoffmann (1986) also investigated the photo-dissolution of hematite in the presence of sulfite and observed a significant increase in Fe(II)_{aq} quantum yield at 367 nm — the peak wavelength of the aqueous phase Fe(III)-S(IV) complex LMCT band. Given that the LMCT band of any surface Fe(III)-S(IV) complex is likely to occur at a similar wavelength, photo-induced charge transfer within the surface-located complex provides the simplest explanation consistent with experimental results, but reductive dissolution as a consequence of direct excitation of the bulk solid cannot be discounted. Litter and Blesa (1988) concluded that a semiconductor mechanism reasonably accounted for the photo-dissolution of maghemite (γ -Fe₂O₃) in the presence of ethylenediaminetetraacetic acid (EDTA) but found that EDTA oxidation also occurred only when surface-located EDTA-Fe(III) LMCT bands were excited. There is evidence also that, in some cases, solution phase photo-processes may play an important role

in dissolution of metal oxides/hydroxides. Thus, Cornell and Schindler (1987) observed an initial slow release of soluble iron in the presence of oxalic acid (an important component of soils and sediments) followed by a much faster reaction. These authors proposed a two-stage reaction: (a) comparatively slow release of Fe(III) through complexation by adsorbed oxalate; and (b) a faster, secondary reductive dissolution step involving electron transfer from re-adsorbed Fe(II) (present at the oxide surface as ferrous oxalate) which is formed principally as a result of solution phase photo-reduction of ferric oxalate.

Metals Release and Surface Alteration

Although the role of oxidizable sorbents in the primary light absorption process appears to depend very much on the particular situation, the nature of these agents and the quantity sorbed at the particle surface will clearly be critical in determining the rate and extent of photoreduction of solid matrix metal ion. Once reduced, the tendency for metal species to be released to solution will depend, in part, on the nature of the oxide (Leland and Bard, 1987; Waite and Torikov, 1987). For example, lepidocrocite would be expected (and is typically observed) to be more reactive than goethite because, unlike goethite, it has a relatively open layer structure consisting of sheets of $\text{Fe}(\text{O},\text{OH})_6$ octahedra held together by hydrogen bonds resulting in a greater proportion of metal atoms in active sites, i.e., sites having fewer structural bonds at the edges of the sheets (Cornell and Schindler, 1987). The suspension pH will also exert a strong influence on the release of reduced metal ions from the solid with an increasing tendency (in the absence of strong reduced metal ion ligands in solution) for ferrous and manganous ions to be retained at the respective oxide surfaces as the pH increases. The effect on dissolution rate of the increasing affinity of cationic species for increasingly negative surfaces as suspension pH is raised has been clearly shown in the results of studies into the photo-assisted dissolution of a colloidal manganese oxide in the presence of fulvic acid. The presence of reduced metal ions within surface layers of the oxidized lattice may result in phase transformations (e.g., the presence of Fe^{2+} ions at the lepidocrocite surface has been shown to result in the formation of magnetite). At the pH of seawater, any Fe^{2+} formed as a result of photoredox processes (either in solution or at the oxide interface) will rapidly re-oxidize to ferrihydrite. This "fresh" ferrihydrite would be expected to be considerably more soluble and reactive (smaller particle size and higher surface area) than aged colloidal iron oxides (Waite and Morel, 1984).

References

- Anderson, M.A. and F.M.M. Morel (1983). The influence of aqueous iron chemistry on the uptake of iron by the coastal diatom *Thalassiosira weissflogii*. *Limnol. Oceanogr.*, **27**: 789.
- Brand, L.E., W.G. Sunda and R.R.L. Guillard (1983). Limitation of marine phytoplankton reproduction rates by zinc, manganese and iron. *Limnol. Oceanogr.*, **28**: 1182.
- Collienne, R.H. (1983). Photoreduction of iron in the epilimnion of acidic lakes. *Limnol. Oceanogr.*, **28**: 83.

- Cornell, R.M. and P.W. Schindler (1987). Photochemical dissolution of goethite in acid/oxalate solution. *Clays & Clay Minerals*, **35**: 347.
- Entsch, G., R.G. Sim and B.C. Hatcher (1983). Indications from photosynthetic components that iron is a limiting nutrient in primary producers on coral reefs. *Mar. Biol.*, **73**: 17.
- Faust, B.C. and M.R. Hoffmann (1986). Photo-induced dissolution of α -Fe₂O₃ by bisulfite. *Environ. Sci. Technol.*, **20**: 943.
- Finden, D.A.S., E. Tipping, G.H.M. Jaworski and C.S. Reynolds (1984). Light-induced reduction of natural iron(III) oxide and its relevance to phytoplankton. *Nature*, **309**: 783.
- Frese, K.W. and J.H. Kennedy (1983). *Extended Abstracts, 153rd Meeting of the Electrochemical Society, Seattle, WA*, Electrochemical Society, Pennington, New Jersey.
- Hong, R. and D.R. Kester (1986). Redox state of iron in the offshore waters of Peru. *Limnol. Oceanogr.*, **31**: 512.
- Leland, J.K. and A.J. Bard (1987). Photochemistry of colloidal semiconducting iron oxide polymorphs. *J. Am. Chem. Soc.*, **91**: 5076.
- Litter, M.I. and M.A. Blesa (1989). Photodissolution of iron oxides: I. maghemite in EDTA solutions. *J. Colloid Interface Sci.*, (in press).
- Martin, J.H. and R.M. Gordon (1988). Northeast Pacific iron distributions in relation to phytoplankton productivity. *Deep-Sea Res.*, **35**: 177.
- Martin, J.H. and S.E. Fitzwater (1988). Iron deficiency limits phytoplankton growth in the northeast Pacific subarctic. *Nature*, **331**: 341.
- McKnight, D.M. and K.E. Bencala (1988a). Control of dissolved iron concentrations in an acidic mountain stream by photoreduction of hydrous iron oxides. *Limnol. Oceanogr.*
- McKnight, D.M., B.A. Kimball and K.E. Bencala (1988b). Iron photoreduction and oxidation in an acidic mountain stream. *Science*, **240**: 637.
- Sherman, D.M. and T.D. Waite (1985). Electronic spectra of Fe³⁺ oxides and oxide hydroxides in the near IR to near UV. *Amer. Mineral.*, **70**: 1262.
- Stramel, R.D. and J.K. Thomas (1986). Photochemistry of iron oxide colloids. *J. Colloid Interface Sci.*, **110**: 121.
- Sunda, W.G., S.A. Huntsman and G.R. Harvey (1983). Photoreduction of manganese oxides in seawater and its geochemical and biological implications. *Nature*, **301**: 234.
- Sunda W.G. (1988). Trace metal interactions with marine algae. In: *Marine Photosynthesis*, R. Alberte and R.T. Barber (eds.), Oxford University Press, New York.

Waite, T.D. (1986). Photoredox chemistry of colloidal metal oxides. In: *Geochemical Processes at Mineral Surfaces*, J.A. Davis and K.F. Hayes (eds.), ACS Symposium Series 323, American Chemical Society, Washington, D.C.

Waite, T.D. and F.M.M. Morel (1984a). Photoreductive dissolution of colloidal iron oxides in natural waters. *Environ. Sci. Technol.*, **18**: 860.

Waite, T.D. and F.M.M. Morel (1984b). Photoreductive dissolution of colloidal iron oxide: Effect of citrate. *J. Colloid Interface Sci.*, **102**: 121.

Waite, T.D., I.C. Wrigley and R. Szymczak (1988). Photo-assisted dissolution of a colloidal manganese oxide in the presence of fulvic acid. *Environ. Sci. Technol.*, **22**: 778.

Waite, T.D. and A. Torikov (1987). Photo-assisted dissolution of colloidal iron oxides by thiol-containing compounds. *J. Colloid Interface Sci.*, **119**: 228.

7.2 Photolysis of Contaminants on Soils and Sediments

Glenn C. Miller
Department of Biochemistry
University of Nevada
Reno, Nevada 98557

Photolysis of contaminants on particulate matter is mediated by a variety of chemical and physical parameters. These include light screening, energy transfer to and from the contaminant, quantum yield and product alteration due to surface effects, and transport to the irradiated surface. The interaction of these effects complicates modelling the photochemistry of compounds on particles.

Light Screening: Attenuation of light by particles has been studied for both suspended pond and river sediments and also soils. For suspended sediments, light attenuation is the most important process. Light attenuation was measured using malachite green leucocyanide as an actinometer at various depths (Miller, et al., 1979a, 1979b). For a series of suspended sediments, the average attenuation coefficient (K) was 2.6×10^{-3} /mg of suspended sediment. For that attenuation coefficient the depth for 90% attenuation of light for a 10 mg/L concentration was 38 cm. Only compounds with very high sorption coefficients (i.e., DDE) or which have been added to the water at levels exceeding water solubility will have significant sorption to the sediments at that sediment concentration.

Attenuation of light by soils is similarly high. These depths were measured by irradiating relatively immobile compounds which had been homogeneously incorporated into soils. On a variety of soils, the photolysis depths varied between 0.1 mm to 0.7 mm. Attenuation in both cases can be either due to bulk attenuation or to the inner filter effect discussed by Yokley and coworkers (1986).

Energy Transfer: Quenching of excited state molecules (i.e., perylene) by humic substances has been demonstrated in several studies, and may be in part responsible for the photostability of polyaromatic hydrocarbons on particulate such as fly ash (Yokley et al., 1986). The converse energy transfer process from the particle to the contaminant which results in loss has not been established. Other indirect processes such as singlet oxygen generation on soil surfaces are known to be important. Using a variety of singlet oxygen chemical traps, the presence of this oxidant was shown to result in the photooxidation of sulfide containing pesticides such as disulfoton.

Surface Effects: Characterization of the photochemistry of natural soil and sediment surfaces is complicated by the heterogeneity of the surface. A range of inorganic and organic components are likely to exist and will probably have a significant effect on the photochemistry of sorbed molecules. The literature contains several references to product distribution differences between sorbed and solution photochemistry, but models to predict these differences are unavailable.

An example of the difference in photochemistry between particle photolysis and solution photolysis is with octachlorodibenzo-p-dioxin (OCDD) (Miller et al. 1989). Irradiation of OCDD on thin layers of soil for up to 15 days resulted in production of lower chlorinated dioxin congeners. Isomer specific analysis of the irradiated soils indicated that preferential

reduction occurred at the 1,4,6,9 chlorines to give the more toxic 2,3,7,8 substituted congeners. For example, of the 22 possible tetrachlorinated dioxins, 2,3,7,8-tetrachlorodibenzo-p-dioxin (2,3,7,8-TCDD) accounted for approximately one-half of these dioxins recovered from the irradiated soils. In solution, the photolysis rate was substantially more rapid (half-life of one hour in midday sunlight) and 2,3,7,8-TCDD was not observed. No preferential photoreduction at the 1,4,6,9 positions was observed. However, it remains unclear why these differences were found, but may be due to surface sorption effects and relative rates of photolysis of the photoproducts.

Movement: On soils in particular, and to a lesser extent in suspended sediments, movement of the compounds into a light exposed area can dominate the degree of photolysis. Light screening by bulk processes, or the inner filter effect in which the contaminants are hidden within particles, can be modified by movement to the exposed surface. Both hydrocarbon solvents and water can contribute to this process. Chemicals with low Henry's law coefficients which have low volatility can move upward with evaporating water and expose these chemicals to the irradiated soil surface.

Added hydrocarbon (hexadecane) to soils at 1% and 5% substantially increased the degree of photolysis of 2,3,7,8-TCDD on soils. Over a period of 15 days, 2,3,7,8-TCDD on soils without hexadecane was 30% degraded and the rate of photolysis had decreased to almost no perceptible loss. On soils with the hydrocarbon, 2,3,7,8-TCDD was up to 70% degraded, and the rate of loss although slower than the initial rate, still was appreciable. This suggested that 2,3,7,8-TCDD was moving in the hydrocarbon film.

References

- Miller, G.C., V. Hebert, M.J. Miille, R. Mitzel and R.G. Zepp (1989). *Chemosphere*, **18**: 1265.
- Miller, G.C. and R.G. Zepp (1979a). *Environ. Sci. Technol.*, **13**: 860.
- Miller, G.C. and R.G. Zepp (1979b). *Water Research*, **13**: 453.
- Yokley, R., A. Garrison, E. Wehry and G. Mamantov (1986). *Environ. Sci. Technol.*, **20**: 86.

7.3 Effects of Sunlight and Anthropogenic Alterations in Atmospheric Solar Attenuation on Manganese Redox Cycles in Surface Seawater

William G. Sunda and Susan A. Huntsman
Beaufort Laboratory
NMFS, NOAA
Beaufort, North Carolina 28516

Manganese is the eleventh most abundant element in the Earth's crust and is an essential micronutrient for all organisms. It exists in natural waters as insoluble Mn(III) or Mn(IV) oxides or as soluble Mn(II) ions. The relative balance between oxidation of Mn(II) and the reduction of Mn oxides largely controls the solubility of manganese, and thereby regulates the removal of manganese from natural waters via particulate scavenging processes. Although Mn(II) is thermodynamically unstable with respect to oxidation by O₂, slow oxidation kinetics combined with reduction of oxides by organics and other reductants (Stone and Morgan, 1984) permits most of the Mn in oxygenated seawater to exist as soluble Mn(II). Purely chemical rates of oxidation are exceedingly slow in seawater (Sung and Morgan, 1981), and there is substantial evidence that most, if not virtually all, Mn(II) oxidation in seawater is bacterially mediated (Emerson et al., 1982; Tebo et al., 1984; Sunda and Huntsman, 1987, 1988). Electron micrographs reveal that the microbially produced oxides are associated with organic polymeric material (probably acidic polysaccharides) surrounding the bacterial cells (Cowen and Silver, 1984).

Unlike most other transition elements which are depleted in surface waters due to biological removal processes, manganese exhibits a distinct surface maximum relative to concentrations in deeper waters. This maximum is associated with a pronounced minimum in the concentration of Mn oxides, suggesting that it results at least partially from a decrease in Mn removal rates due to the sinking of Mn oxide particles. In one study in the southwestern Sargasso Sea, dissolved manganese occurred at a maximum concentration of 4.3 ± 0.6 nM in the surface mixed layer (0–40 m) and decreased to concentrations of 0.67 ± 0.19 nM at depths of 400–750 m (Sunda and Huntsman, 1988). Particulate Mn, on the other hand, occurred at a minimum in the mixed layer (0.034 ± 0.012 nM or 0.8% of total Mn) and increased to 0.41 to 0.48 nM at depths of 120 to 250 m. All of the increase in particulate Mn with depth occurred within the fraction that could be reductively dissolved by 0.3 mM ascorbic acid at ambient seawater pH, indicating that it resulted from an increase in the concentration of Mn oxides. These oxides were undetectable in the surface mixed layer, but a mean of 94% of the particulate manganese appeared to be associated with oxides at depths of 80 to 250 m.

Radiotracer (⁵⁴MnCl₂) measurements of particulate Mn formation rates and concomitant steady-state calculations of particulate Mn turnover rates indicated that the low particulate Mn concentrations in the mixed layer resulted from both a twenty-fold decrease in formation rates and at least a five-fold increase in particulate dissolution rates near the surface relative to rates at 160 m at the bottom of the photic zone. Incubation experiments conducted in the Sargasso Sea and elsewhere indicate that the formation of particulate ⁵⁴Mn is sharply reduced by exposure to sunlight, apparently due to a photoinhibition of microbial Mn(II) oxidizing bacteria (Sunda and Huntsman, 1988 and submitted). This

photoinhibition appears to be primarily responsible for the observed decrease in particulate Mn formation rates in the mixed layer of the southwestern Sargasso Sea.

Photoinhibition of microbial Mn oxidation had different characteristics in oceanic and coastal seawater. In the southwestern Sargasso Sea, particulate Mn formation rates were equally depressed in near-surface samples collected at sunrise and sunset, suggesting no diel variation in the rates. However, in a diel study in surface coastal waters of nearby Eleuthera Island, Bahamas, there was a pronounced diel cycle in Mn(II) oxidation rates in which specific rates during the late afternoon were 1/20th to 1/70th of maximum night-time rates (Sunda and Huntsman, submitted). Thus, there appears to be a nighttime recovery from photoinhibition in more productive coastal waters, but no such recovery in oligotrophic oceanic waters. The reasons for the observed differences in diel patterns are not known.

Sunlight exposure experiments were conducted with both radiolabeled Mn oxides synthesized in the laboratory by permanganate oxidation of $^{54}\text{Mn(II)}$ and radiolabeled natural oxides produced *in situ* from microbial oxidation of $^{54}\text{Mn(II)}$. Results of these experiments indicate that the observed apparent increase in the dissolution of Mn oxides in near-surface Sargasso Sea water can be accounted for by a stimulation of oxide reduction rates by sunlight (Sunda et al., 1982; Sunda and Huntsman, 1988 and in prep.). Dissolution of naturally produced oxides in the presence of full sunlight followed pseudo-first order kinetics with specific rates of 0.06 to 0.13 h^{-1} (mean = $0.098 \pm 0.024[\pm\text{ds}]$, $n=12$) in estuarine, coastal and oceanic samples (Sunda and Huntsman, in prep.). Dissolution rates in the dark were much lower and more variable and showed a mean of $0.006 \pm 0.0050 \text{ h}^{-1}$ ($n=12$), about 7% of the value in full sunlight.

The exact mechanism of the photoreductive dissolution of natural oxides is unknown, but one possibility is the photochemical production of H_2O_2 , a known reductant for Mn oxides. Experiments with the laboratory synthesized oxides revealed a second order rate constant for H_2O_2 dissolution of these oxides of $0.14 \mu\text{M}^{-1} \text{ h}^{-1}$ of H_2O_2 . The addition of catalase, which enzymatically removes H_2O_2 , reversed ca. 80% of the sunlight effect on dissolution of these oxides implicating H_2O_2 as an important reactive intermediary. Parallel experiments revealed a lower range of second order rate constants [0.02 to $0.05 \mu\text{M}^{-1} \text{ h}^{-1}$] for the dissolution of natural oxides by H_2O_2 . This finding combined with several-fold higher photodissolution rates of natural oxides compared to rates of synthetic oxides suggests that photochemical production of H_2O_2 does not play a major role in the photodissolution of the natural oxides. This prediction was confirmed by the inability of added catalase to appreciably reduce the dissolution of the natural oxides in the presence of sunlight.

Unlike synthetic oxides, the photodissolution of the natural oxides is relatively unaffected by the addition of 5 mg liter^{-1} marine humic acids or by the removal of photoactive organic matter by prior uv-photooxidation (Sunda and Huntsman, in prep.). Also similar photodissolution rates were observed in waters of different natural organic contents. These findings indicate that the reducing electrons for the photoreduction of the natural oxides are derived from the particles themselves (possibly from organic matter associated with the oxides) rather than from organic matter in the surrounding water. Possible photoreductive mechanisms that are consistent with these observations include (1) photochemical charge transfer reactions between manganese oxides and associated organic biopolymers onto which the oxides are deposited or (2) the localized production of superoxide radicals from photoexcitation of organic matter associated with the oxides. Superoxide radicals produced from

the oxidation of xanthine by xanthine oxidase readily reduce natural Mn oxides (Sunda and Huntsman, in prep.); and thus, any such radicals that are produced by photoreactions with organic matter at or near oxide surfaces would be likely to rapidly react with the oxides liberating dissolved Mn(II).

The photodissolution of natural radiolabeled oxide occurred at the same rate in quartz tubes that are transparent to uv-light and Pyrex glass bottles that absorb light at wavelengths below 350 nm and show $\geq 50\%$ absorption at or below 327 nm (Sunda and Huntsman, in prep.). Thus, the uv-B region of the solar spectrum (290–320 nm) does not appear to contribute measurably to the photodissolution of natural Mn oxides. The dissolution of these oxides by sunlight, however, is reduced by roughly 30% in polycarbonate bottles that absorb light below 380 nm and show a 50% absorption at 350 nm. The difference in rates observed in glass and polycarbonate bottles indicates that near uv-light between ~ 350 and 380 nm contributes to the photo-dissolution of the natural oxides.

No systematic experiments have been conducted on the influence of spectral wavelength on the photoinhibition of microbial Mn(II) oxidation. However, like most biological photoinhibitions it is likely that shorter wavelength, higher energy photons will be particularly deleterious to manganese oxidizing bacteria. In an experiment with Sargasso Sea water held in polycarbonate bottles we observed an 80% inhibition of particulate Mn formation rates after four hours exposure to sunlight (Sunda and Huntsman, 1988). Since the polycarbonate bottle was essentially opaque to light below 330 nm, the results indicate that sunlight with wavelengths longer than 330 nm contributes to photoinhibition of microbial Mn oxidation.

In conclusion, both the photoinhibition of microbial Mn(II) oxidation and the photoreductive dissolution of Mn oxides decreases the accumulation of Mn oxide particles in near-surface seawater leading to a decrease in the removal of manganese from these waters due to particulate scavenging processes. Any anthropogenic alterations in the atmosphere leading to increased cloud cover (such as greenhouse warming or the release of cloud nuclei), should decrease the magnitude of these two photoeffects, resulting in a decrease in Mn retention in surface waters and a potential decrease in surface Mn concentrations. Such effects may have an adverse effect on phytoplankton which require Mn for photosynthetic electron transport and for the dismutation of toxic superoxide radicals. Increases in uv-B radiation due to anthropogenic ozone depletion, on the other hand, may have the opposite effect. From the above mentioned results, it is unlikely that a moderate ozone depletion will have much effect on the photodissolution of manganese oxides, but it may well cause further decreases in microbial Mn(II) oxidation in surface waters leading to decreases in particulate Mn scavenging rates. Because of the potentially opposing effects of increased cloud cover and ozone depletion, the overall effect of anthropogenic changes in atmospheric solar attenuation on Mn concentrations and biological availability in surface sea water remains uncertain.

References

- Cowen, J.P. and M.W. Silver (1984). The association of iron and manganese with bacteria on marine macroparticulate material. *Science*, —bf 224: 1340–1342.

- Emerson, S., S. Kalthorn, L. Jacobs, B.M. Tebo, K.H. Nealson and R.A. Rosson (1982). Environmental oxidation rate of manganese (II): bacterial catalysis. *Geochim. Cosmochim. Acta*, **46**: 1073-1079.
- Stone, A.T. and J.J. Morgan (1984). Reduction and dissolution of manganese(III) and manganese(IV) oxides by organics: Survey of the reactivity of organics. *Environ. Sci. Technol.*, **18**: 617-624.
- Sunda, W.G. and S.A. Huntsman (1987). Microbial oxidation of manganese in a North Carolina estuary. *Limnol. Oceanogr.*, **32**: 552-564.
- Sunda, W.G. and S.A. Huntsman (1988). Effect of sunlight on redox cycles of manganese in the southwestern Sargasso Sea. *Deep-Sea Res.*, **35**: 1297-1317.
- Sunda, W.G. and S.A. Huntsman (submitted). Diel cycles in microbial manganese oxidation and manganese redox speciation in coastal waters of the Bahama Islands. *Limnol. Oceanogr.*
- Sunda, W.G. and S.A. Huntsman (in preparation). Photoreduction of manganese oxides in seawater.
- Sunda, W.G., S.A. Huntsman and G.R. Harvey (1983). Photoreduction of manganese oxides in seawater and its geochemical and biological implications. *Nature*, **301**: 234-236.
- Sung, W and J.J. Morgan (1981). Oxidative removal of Mn(II) from solution by the γ -FeOOH (lepidocrodite) surface. *Geochim. Cosmochim. Acta*, **45**: 2377-2383.
- Tebo, B.M., K.H. Nealson, S. Emerson and L. Jacobs (1984). Microbial mediation of Mn(II) and Co(II) precipitation at the O_2/H_2S interfaces in two anoxic fjords. *Limnol. Oceanogr.*, **29**: 1247-1258.

7.4 Sunlight-dependent Changes in the Pigment Content and Spectral Characteristics of Particulate Organic Material Derived from Phytoplankton

James R. Nelson
Skidaway Institute of Oceanography
P.O. Box 13687
Savannah, Georgia 31416

The absorption of visible light by particulate organic matter in natural waters is a composite property, representing the contributions of variety of organic chromophores. Since the optical properties of the water column can be greatly influenced by biological and chemical factors, interpreting the signals received by optical instruments in terms of particle concentrations and particle types has become an interdisciplinary subject. Aspects of this problem include identifying the spectral characteristics of different classes of particulate organic matter, and determining how sunlight affects various organic chromophores associated with particles.

In several studies, using a number of approaches, the absorption spectra of particulate material from natural waters have been partitioned into two components: 1) the absorption by phytoplankton pigments, and 2) the absorption by what has been classified as "organic detritus" (e.g., Kiefer and SooHoo, 1982; Kishino et al., 1984; Maske and Haardt, 1987). Spectrally, these two operational classes of organic chromophores are quite different. The pigments associated with the photosynthetic membranes of phytoplankton show distinctive absorption spectra in the visible, with high specific absorption in certain wavebands. "Detrital" chromophores typically have low or negligible absorption at longer wavelengths in the visible, but show a steady, featureless increase in absorption from the blue into the near-UV. Similar absorption spectral appear to be characteristic of particulate organic matter collected from the deep ocean waters (Yentsch, 1962).

Due to their biological significance, much attention has been focused upon the pigments associated with the photosynthetic membranes of phytoplankton. However, within the upper water column, not all of these pigments are necessarily associated with living phytoplankton. Phytoplankton pigments could be contained in dead cells, in the egested particulate wastes of microzooplankton grazers, in the feces and fragments of feces produced by larger grazers, and, in shallow water columns, in resuspended sedimentary material. The primary focus of the present study has been to examine the effects of visible light on the pigment composition and on the spectral character of organic detritus derived from phytoplankton. Light-dependent rates of pigment photodegradation were determined in laboratory studies, along with parallel measurements of particulate absorption spectra.

Results of these experiments indicate that photooxidative degradation of phytoplankton chlorophylls, pheopigments and carotenoids contained in detrital particles would occur fairly rapidly in near-surface waters. The pattern of pigment degradation suggests that pigment photooxidations could occur by a photosensitized mechanism. Chlorophylls and their pheopigment derivatives are known to be sensitizers of photooxidations. Such sensitized reactions might be enhanced due to the localization of the hydrophobic pigments within hydrophobic microenvironments in detrital particles.

Although the photosynthetic pigments were degraded fairly rapidly in the light, organic material derived from phytoplankton still showed significant absorbance of light in the blue and near-UV regions, similar to the "detrital" chromophores described above. Clearly this class of chromophores, here defined only by the near-UV and visible absorption spectra, is likely to be composed of a heterogeneous pool of organic compounds. The visible portions of the absorption spectra of the "detrital" chromophores would represent the longer wavelength "tails" of absorption spectra which reach maxima in the UV.

It is of interest to note that such "detrital" chromophores can dominate particulate absorption in waters from quite different environments. In the shallow waters of the S.E. U.S. continental shelf, high particle loads are kept in suspension by strong tidal and wind mixing on the shoreward side of the coastal frontal zone. Not surprisingly, "detrital" chromophores dominate total particulate absorption in these waters (Nelson, unpublished data). However, field studies in open ocean areas that are well isolated from sources of sedimentary particles (e.g., Mitchell and Kiefer, 1988) have also shown that the "detrital" type chromophores can be of considerable significance in particulate absorption in near-surface waters. Such material would likely be of biogenic origin.

Thus, the presence of particulate organic chromophores with strong UV absorbance appears to be a feature common to both coastal and at least some oceanic waters. Assessing the potential effects of UV radiation on this "detrital" class of organic chromophores will require a better characterization of the chemical composition and photochemical activity of its constituents.

References

- Kiefer, D.A. and J.B. Soohoo (1982). Spectral absorption by marine particles of coastal waters of Baja California. *Limnol. Oceanogr.*, **27**: 492-499.
- Kishino, M., C.R. Booth and N. Okami (1984). Underwater radiant energy absorbed by phytoplankton, detritus, dissolved organic matter, and pure water. *Limnol. Oceanogr.*, **29**: 340-349.
- Maske, H. and H. Haardt (1987). Quantitative *in vivo* absorption spectra of phytoplankton: detrital absorption and comparison with fluorescence excitation spectra. *Limnol. Oceanogr.*, **32**: 620-633.
- Mitchell, B.G. and D.A. Kiefer (1988). Variability in pigment specific particulate fluorescence and absorption spectra in the North Eastern Pacific Ocean. *Deep-Sea Res.*, **35**: 665-689.
- Yentsch, C.S. (1962). Measurements of visible light absorption by particulate matter in the ocean. *Limnol. Oceanogr.*, **7**: 207-217.

7.5 Indirect Effects of UV Radiation on Phytoplankton

F.M.M. Morel and N.M. Price
Department of Civil Engineering
Massachusetts Institute of Technology
Cambridge, Massachusetts 02139

On the basis of quasi-perfect ignorance and no facts to contradict us, we are willing to argue vehemently on all sides of this issue: increased UV radiation (i) will promote a dramatic increase in new production, (ii) will practically destroy marine productivity, and (iii) will have no discernible effect on phytoplankton growth.

The first conclusion is based on the hypothesized or documented control of oceanic new production by the availability of micronutrients, iron and manganese in particular (Sunda and Huntsman, 1983; Sunda et al., 1981; Martin and Gordon, 1988; Martin et al., 1989). Trace metals in particulate material or bound to organic ligands are effectively not available to phytoplankton (Sunda and Guillard, 1976; Anderson and Morel, 1982; Rich and Morel, submitted). Increased photoreductive dissolution of oxides and destruction of organic chelators by increased UV light will make the metals more available. The result will be a dramatic increase in new production in the high latitude and equatorial oceans.

Destruction of marine production by increased UV light is inevitable. This is because the algae are already stressed by the presence of reactive intermediates of photochemical reactions (O_2^- , $OH\cdot$, H_2O_2 , $ROOH$, etc.) and the biochemical defense mechanisms require specific trace elements (Fe, Mn and Se in particular, (Halliwell, 1974)) which are in limited supply; they cannot function more efficiently than they already do. This is exemplified by the limitation of phytoplankton by selenium availability (Price and Harrison, 1988; Price et al., 1987). Selenium, an integral component of glutathione peroxidase (GSH-Px), is necessary for phytoplankton growth. Selenite, the bioavailable form of Se, is depleted in the surface oceans (Measures and Burton, 1980). In some marine samples, selenium additions promote carbon fixation. Since Se has no other biological function than GSH-Px in marine algae, these are evidently under some kind of peroxide stress. Additional production of H_2O_2 by UV light should effectively sterilize seawater.

Marine phytoplankton already cope with reactive photoproducts and trace element depletion and additional UV light will have no measurable effect on their growth. Several species produce hydrogen peroxide through the activity of ectoenzymes (Palenik and Morel, 1988, submitted) and are certainly able to cope with the resulting high concentration at the cell surface. We have found evidence of extracellular peroxidase and dismutase activity in marine algae. Further, transmembrane reductases (Jones et al., 1987) should readily detoxify hydroxy radicals if they were sufficiently long lived to reach the cell surface. More generally, the marine biota has evolved to cope successfully with a variety of environmental limitations. Primary production is limited by fundamental physical and chemical processes such as advection of nutrients or chemical rate laws (Redfield, 1934; Morel and Hudson, 1985; Hudson and Morel, 1990). A deepening of the surface layer in which UV light is deleterious to algae (indirectly or directly) should have no effect on oceanic primary production.

References

- Anderson, M.A. and F.M.M. Morel (1982). The influence of aqueous iron chemistry on the uptake of iron by the coastal diatom *Thalassiosira weissflogii*. *Limnol. Oceanogr.*, **27**: 745-752.
- Halliwell, B. (1974). Superoxide dismutase, catalase and glutathione peroxidase: solutions to the problems of living with oxygen. *New Phytol.*, **73**: 1075-1086.
- Hudson, R.J.H. and F.M.M. Morel (1990). Trace metal transport by aquatic microorganisms: implications of metal coordination kinetics. (In preparation).
- Jones, G.J., B. Palenik and F.M.M. Morel (1987). Trace metal reduction by phytoplankton: The role of plasmalemma redox enzymes. *J. Phycol.*, **23**: 237-244.
- Martin, J.H. and R.M. Gordon (1988). Northeast Pacific iron distributions in relation to phytoplankton productivity. *Deep-Sea Res.*, **35**(2): 177-196.
- Martin, J.H., R.M. Gordon, S. Fitzwater and W.W. Broenkow (1989). VERTEX: phytoplankton/iron studies in the Gulf of Alaska. *Deep-Sea Res.*, **36**: 649-680.
- Measures, C.I. and J.D. Burton (1980). The vertical distribution and oxidation states of dissolved selenium in the Northeast Atlantic Ocean and their relationship to biological processes. *Earth Planet. Sci. Lett.*, **46**: 385-396.
- Morel, F.M.M. and R.J.M. Hudson (1985). The geobiological cycle of trace elements in aquatic systems: Redfield revisited. In: *Chemical Processes in Lakes*, W. Stumm (ed.), John Wiley, New York.
- Palenik, B. and F.M.M. Morel (1988). Dark production of H₂O₂ in the Sargasso Sea. *Limnol. Oceanogr.*, **33**: 1606-1611.
- Palenik, B. and F.M.M. Morel (1990). Amino acid utilization by marine phytoplankton: A novel mechanism. *Limnol. Oceanogr.*, (submitted).
- Price, N.M. and P.J. Harrison (1988). Specific selenium-containing macromolecules in the marine diatom *Thalassiosira pseudonana*. *Plant Physiol.*, **86**: 192-199.
- Price, N.M., P.A. Thompson and P.J. Harrison (1987). Selenium: an essential element for growth of the coastal marine diatom *Thalassiosira pseudonana* (bacillariophyceae). *J. Phycol.*, **23**: 1-9.
- Redfield, A.C. (1934). On the proportions of organic derivatives in the sea water and their relation to the composition of plankton. In: *James Johnstone Memorial Volume*, Liverpool University Press, pp. 176-192.
- Rich, H.W. and F.M.M. Morel (1990). Bioavailability of well-defined iron colloids to the marine diatom *Thalassiosira weissflogii*. *Limnol. Oceanogr.*, (submitted).

- Sunda, W.G. and S.A. Huntsman (1983). The effect of competitive interactions between manganese and copper on cellular manganese and growth in estuarine oceanic isolates of *Thalassiosira pseudonana*. *Limnol. Oceanogr.*, **28**: 924-934.
- Sunda, W.G. and R.R.L. Guillard (1976). The relationship between cupric ion activity and the toxicity of copper to phytoplankton. *J. Mar. Res.*, **34**: 511-529.
- Sunda, W.G., R.T. Barber and S.A. Huntsman (1981). Phytoplankton growth in nutrient rich seawater: importance of copper-manganese cellular interactions. *J. Mar. Res.*, 567-586.

8 UV Effects on Biological Processes

8.1 Biological Action Spectroscopy - Role in Estimating Effects Due to Stratospheric Ozone Depletion

Thomas P. Coohill
Department of Physics & Astronomy
Western Kentucky University
Bowling Green, Kentucky 42101

By 1988, the scientific community had reached agreement that a portion of the earth's protective stratospheric ozone layer was being depleted, largely by man-made chemicals. The immediate question then became, "what will this mean for the world?" The most important direct consequence of this loss of ozone is an increase in the amount of a certain portion of the UV spectrum reaching the earth's surface. This increase will be largely confined to the wavelength region 295–315 nm since shorter wavelengths are absorbed by other atmospheric components, while longer ones penetrate the current atmospheric column. This narrow region is a large fraction of the so-called UVB (290–320 nm). Thus the effects of O₃ depletion can be assessed by estimating or measuring the additional consequences of increased UVB-exposure. These consequences are largely biological. Hence, a broad understanding of the UVB photobiology of living organisms is essential, if we are to estimate the worldwide effect of O₃ depletion. What follows is a first attempt at such estimations and a description of the biological assay most applicable to this problem. Future estimates will follow as the amount of data collected on these systems increases. A goal is to provide the scientific, governmental, and public communities with reasonable, scientifically based values that can be of use for determining appropriate responses to this worldwide problem.

The vast majority of biological organisms evolved after the initial formation of the stratospheric O₃ layer. This layer provided for living forms an umbrella of protection from the deleterious effects of UV by absorbing heavily those UV wavelengths below 320 nm. It is probably not a coincidence that the single most important molecule in living cells, i.e., the genetic material DNA, has an absorption spectrum that peaks at 260 nm (well below 320 nm) and drops by three orders of magnitude at 320 nm. Even so, there is enough ambient UVB reaching the biosphere to produce some damage to cellular DNA. UV effects on DNA are widely reported and include such photochemical changes as pyrimidine dimers, 6–4 photoproducts, DNA-protein cross links, and lesions that can lead to single and double strand breaks. If left unrepaired, these lesions may lead to impairment, mutation, or even cell death. For these reasons, some organisms avoid exposure to high levels of ambient UV, or are advised to do so in the case of humans, to prevent serious damage. The biochemical and physiological consequences of UV exposure to some biological system are well characterized and reasonably well understood when compared with other insults, e.g., ionizing radiation.

One technique that allowed for early advances in UV photobiology is that of action spectroscopy. Over one hundred years ago, crude action spectra were the first assays to identify the chlorophylls as the primary photoreceptors in plant growth. In 1930 an action spectrum by F.L. Gates was the first clear evidence that DNA was the genetic material in cells. Thus, action spectroscopy is central to understanding many important biological processes and is

often the method of choice for first determinations of biological effects. Simply described, an action spectrum is a plot of biological effect as a function of wavelength. However, several important conditions must be met if an accurate action spectrum is to be claimed, and compromises usually limit the applicability of any given action spectrum. These conditions include: that at no λ is more than a small fraction of the incident radiation absorbed by the sample; that scattering and absorption in front of the target chromophore(s) is negligible or, at least, constant at all λ 's (or correctable); that the chromophore absorb the same *in vitro* as *in vivo*; that the quantum yield is the same at all λ 's; that the exposure response curves are superimposable at all λ 's after a dose modification factor; and that reciprocity of time and exposure rate holds. Only rarely are even some of the above requirements met by living cells. In addition, some variables can obscure results obtained in different laboratories, for example: the degree of spectral purity; dosimetry; accurate radiation measurements at the sample; the presence of exogenous and/or endogenous pigments; the extent of biological repair of damage before assay; the physical state of the target molecule(s), etc. Because of the stringent requirements for detailed action spectra, rough ones are often generated, which, or course, only provide crude estimates. The rigorous approach of exposing samples to stringently filtered single narrow wavebands of UV is helpful, and sometimes conclusive, in identifying the chromophore(s) responsible for a given biological effect. Other types of "action spectrum" are also useful. These vary from irradiating the affected system with single UV wavelengths only, adding single wavelengths to a "white" light background, or generating a set of data using polychromatic sources that employ cut-off filters at successively shorter wavelengths. The monochromatic system is accurate, is the preferred way for determining the target chromophore, and is the classical method for generating a true action spectrum, i.e., a plot of biological effect as a function of single-wavelength irradiations. However, this system is highly artificial and greatly removed from the natural setting. The polychromatic system is complex, tends to obscure individual chromophores, but is closest to natural field conditions. A major advantage of using polychromatic radiation in the development of action spectra is that interactions of cellular responses to different wavelengths (usually unknown) can be empirically incorporated into the composite spectrum. For example the involvement of photorepair systems or other cell responses to longer wavelength radiation that might mitigate the damaging effect of shorter-wavelength radiation can be assessed without knowing about the nature or spectra for these repair and/or mitigating responses. In addition, a polychromatic action spectrum is useful because of its closer relation to the natural setting.

Once definitive action spectra are obtained, they can be combined with the known amount of ambient radiation to produce an "effectiveness spectrum" that charts the actual effect in nature. For example, the action spectrum for human erythema (sunburn) combined with the known solar spectrum reaching the earth's surface, gives rise to a "solar erythemal effectiveness spectrum," that shows the peak wavelength (308 nm) responsible for sunburning in humans, and the contributions by other wavelengths. If a degree of O₃ depletion is assumed one can then compare the solar effectiveness spectra for a normal and an O₃ depleted environment and determine the increase in effect due to the latter.

These effectiveness spectra and other results allow making initial approximations of the biological consequences of O₃ depletion. The following table should only be viewed as a

rough estimate, containing values that will surely change as more information becomes available.

**For Each 1% Decrease in Stratospheric Ozone
You Can Estimate**

- 1) a 3% increase in skin cancer.
- 2) a 2% increase in human cataracts.
- 3) a 2% decrease in human immune system protection.
- 4) a 3% decrease in some fish harvests (mainly due to a decrease in available plankton).
- 5) a 1% decrease in the yields of certain crops, such as rice and soybeans.

References

- Coohill, T.P. (1985). Action spectra for mammalian cells *in vitro*. In: *Topics in Photomedicine*, K.C. Smith (ed.), Plenum Press, New York, pp. 1-37.
- Coohill, T.P., M.J. Peak and J.G. Peak (1987). The effects of the ultraviolet wavelengths of radiation present in sunlight on human cells *in vitro*. *Photochem. Photobiol.*, 16: 1043-1050.
- Daubeny, C. (1836). On the action of light upon plants and plants upon the atmosphere. *Phil. Trans. Roy. Soc. London*, 149-179.
- Federick, J.E. and D. Lubin (1988). Possible long-term changes in biologically active ultraviolet radiation reaching the ground. *Photochem. Photobiol.*, 47: 571-578.
- Gates, F.L. (1930). A study of the bacterial action of ultraviolet light. III The absorption of ultraviolet light by bacteria. *J. Gen. Physiol.*, 14: 31-42.
- Jagger, J. (1985). *Solar-UV Actions on Living Cells*. Praeger, New York.
- Peak, J.J. and J.G. Peak (1983). Use of action spectra for identifying molecular targets and mechanisms of action of solar ultraviolet light. *Physio. Plan.*, 58: 360-366.
- Worrest, R.C. (1986). The effect of solar UV-B radiation on aquatic systems: an overview. In: *Effects of Changes in Stratospheric Ozone and Global Climate. Vol. 1. Overview*, J.G. Titus (ed.), U.S. Environmental Protection Agency and United Nations Environmental Program, p. 175.

8.2 UV-B Effects on Plants, Herbivores, and Phytopathogens

Richard A. Larson
University of Illinois
Institute for Environmental Studies
Environmental Research Laboratory
1005 Western Avenue
Urbana, Illinois 61801

Current calculations predict that shortwave solar ultraviolet (UV-B) light intensities at the Earth's surface will increase as stratospheric ozone concentrations diminish due to current and future inputs of reactive chemical species such as chlorofluorocarbons and oxides of nitrogen. Many laboratory experiments suggest biological damage due to increases in UV-B is likely to occur for many types of organisms, but little attention has been paid to changes that may take place in interactions between species. In particular, plants exposed to increased UV-B levels undergo physiological and biochemical changes that may render them more or less susceptible to attack by herbivorous insects or infection by pathogenic microorganisms. Although this presentation will focus on the effects of increasing UV-B on terrestrial ecosystems, in principle the same sort of phenomena could occur in fresh or saltwater primary producer communities.

Ultraviolet radiation has the potential for reacting with and damaging biochemically important entities such as cell membranes and enzymes (Larson and Berenbaum, 1988). For example, the amino acid tryptophan absorbs short-wave solar UV strongly (Sun and Zigman, 1979) and is converted by light into a complex mixture of products. Presumably this process would be deleterious for an enzyme with tryptophan at its active site. Another mechanism for biological interaction of light with molecules is an indirect effect that occurs when sunlight is absorbed by molecules and converts them to toxic or reactive forms capable of inducing cellular damage. A compound that exemplifies this second type of reaction is xanthotoxin (8-methoxypsoralen), a natural occurring furanocoumarin found in several plant families; its photochemically excited states react with DNA, forming covalent adducts (Song and Tapley, 1979), and it forms similar adducts with unsaturated fatty acids of the type found in membranes (Specht et al., 1988). Photoactivated molecules of many types, including furanocoumarins, can also interact with ground state oxygen to form excited singlet oxygen (1O_2 ; Larson, 1986). Singlet oxygen is highly reactive and can damage proteins, membrane lipids, and DNA bases at varying rates. We (Berenbaum and Larson, 1988) recently demonstrated that leaves of *Zanthoxylum americanum* generate singlet oxygen at their surface in the presence of simulated sunlight, perhaps at levels sufficiently high to induce damage in cells of organisms on or near the leaf surface; nonrutaceous plants lacking photosensitizers lack this ability. Moreover, absorption of light by phototoxins can result in the formation of electronically activated oxygen species such as superoxide, hydrogen peroxide, and hydroxyl radical, via reaction sequences beginning with photoejected electrons and oxygen. These transient forms are also capable of damaging biomolecules critical to physiological function. Furanocoumarins and other phototoxic molecules such as certain alkaloids (β -carboline, Larson et al., 1988; quinine, Larson and Marley, in preparation; sanguinarine, Tuveson et al., in preparation) can be efficient producers of these forms.

There have been many reports of deleterious physiological effects of solar UV, particularly UV-B, on plants, including reductions in plant height, number of leaves, leaf area, tissue damage, losses or increases in chlorophyll and protein concentrations, effects on stomatal opening processes, reductions in net photosynthesis and nitrogen fixation, and reductions in activity of essential enzymes (Teramura, 1983). The effects of increased UV-B are particularly marked at low intensities of visible light (Teramura et al., 1980). While UV-B wavelengths are not used directly for photosynthesis, they can affect the process indirectly by altering enzyme efficiency, chlorophyll pigment structure (and hence light-gathering capacity) and lipid and carbohydrate pools (Berenbaum, 1988). Species of crop plants differ in their susceptibility to increased UV-B; corn is rather resistant, radish and barley are of intermediate sensitivity, and bean is highly susceptible (Tevini and Iwanzik, 1982). In addition to protective enzymes such as catalase and superoxide dismutase, plants contain varying levels of potentially antioxidative constituents that allow them to survive in the presence of potentially damaging UV, such as vitamins E and C, alkaloids, flavonoids and other phenolic compounds, and carotenoids (Larson, 1988).

Exposure of a variety of plants to experimentally increased UV-B has shown that concentrations of many constituents are altered, including:

- furanocoumarins, increased in parsnip (*Pastinaca sativa*) above-ground parts (Zangerl and Berenbaum, 1987);
- flavonoids, increased in columbine (*Aquilegia canadensis* and *A. caerulea*) above-ground parts, soybean (*Glycine max*) leaves, cucumber (*Cucumis sativus*) cotyledons and radish (*Raphanus sativus*) leaves (Murali and Teramura, 1985; Larson and Garrison, in preparation; Tevini et al., 1983);
- isoflavonoids, increased in bean (*Phaseolus vulgaris*) leaves (Beggs et al., 1985);
- cuticular waxes, increased in cucumber (Tevini and Steinmueller, 1987);
- cannabinoids, increased in *Cannabis sativa* (Lydon et al., 1987);
- carotenoids, reduced in bean, radish, corn (*Zea mays*), soybean (*Glycine max*), barley (*Hordeus vulgare*), tomato (*Lycopersicon esculentum*), and columbine (*Aquilegia canadensis* and *A. caerulea*) species (Tevini and Iwanzik, 1982; Vu et al., 1982; Larson and Garrison, in preparation; Prudot and Basiouny, 1982); and
- alkaloids, reduced in columbine (*Aquilegia*) above-ground parts (Larson and Garrison, in preparation).

Many of these compounds could play roles in either defense against direct toxicity due to light-induced effects in the plants themselves, or against pest species, or both. For example, increased levels of cuticular waxes could increase UV-B reflectance from plant surfaces, and also increase the fraction of indigestible material a herbivorous insect would ingest and thus impact growth (Berenbaum, 1988). Alkaloids, carotenoids, and flavonoids may possibly act as antioxidants, as filters to screen out harmful UV wavelengths, or as insect feeding deterrents (Berenbaum, 1988). In addition to protecting plant species from attack by insects, phototoxic molecules may serve to protect against infection by phytopathogenic

fungi and bacteria (Downum and Nemec, 1987). Antioxidant enzymes such as superoxide dismutase and catalase may not only protect against elevated levels of active oxygen species generated by photoactivated plant chemicals they may also alter the efficacy of oxygen radical generating systems in plant tissues that confer resistance against pathogens (Doke and Chai, 1985; Buonavrio et al., 1987; Aver'Yanov et al., 1987). However, very little information has been collected with regard to how effects of increased UV-B on plants might affect plant-herbivore and plant-pathogen relationships. In principle, three types of consequences could develop:

- i. Concentrations of nutrients important for metabolic requirements, such as proteins, may increase or decrease by light exposure.
- ii. Concentrations of antioxidants or antioxidant enzymes may increase or decrease and, if ingested or absorbed by herbivores or pathogens, alter their susceptibility to light or phototoxins.
- iii. Concentrations of phototoxic chemicals may increase or decrease under light stress, with corresponding increased or decreased inhibitory effects on associated populations of herbivores or pathogenic microorganisms.

Thus, one likely consequence of changes in plant physiology and chemistry resulting from increased exposure to UV-B is that, in one way or another, these changes will effect plant resistance to damage by herbivorous insects and microbial pathogens.

References

- Aver'Yanov, A.A., B.P. Lapikova, A.M. Umnov and V.G. Dzhavakyya (1987). Generation of superoxide radical by rice leaves in relation to blast resistance. *Soviet Plant Physiol.*, **34**: 301-306.
- Beggs, C.J., A. Stolzer-Jehle and E. Wellmann (1985). Isoflavonoid formation as an indicator of UV stress in bean (*Phaseolus vulgaris*) leaves. The significance of photorepair in assessing potential damage by increased solar UV-B radiation. *Plant Physiol.*, **79**: 630-634.
- Berenbaum, M. (1988). Effects of electromagnetic radiation on insect-plant interactions. In: *Plant Stress-Insect Interactions*, E. Heinrichs (ed.), J. Wiley and Sons, Inc., New York, pp. 167-185.
- Berenbaum, M.R. and R.A. Larson (1988). Flux of singlet oxygen from leaves of phototoxic plants. *Experientia*, (in press).
- Buonavrio, R., G. Della Torre and P. Montalbini (1987). Soluble superoxide dismutase (SOD) in susceptible and resistant host-parasite complexes of *Phaseolus vulgaris* and *Uromyces phaseoli*. *Physiol. Mol. Plant Pathol.*, **31**: 173-184.
- Doke, N. and H.B. Chai (1985). Activation of superoxide generation and enhancement of resistance against compatible roles of *Phytophthora infestans* in potato plants treated with digitonin. *Physiol. Plant Pathol.*, **27**: 323-334.

- Downum, K.R. and S. Nemeč (1987). Light-activated antimicrobial chemicals from plants: Their potential role in resistance to disease-causing organisms. In: *Light-activated pesticides*, J.R. Heitz and K.R. Downum (eds.), American Chemical Society Symposium Series, **339**: 281-294.
- Larson R.A. (1986). Insect defenses against phototoxic plant chemicals. *J. Chem. Ecol.*, **12**: 859-870.
- Larson, R.A. and M.R. Berenbaum (1988). Environmental phototoxicity. *Environ. Sci. Technol.*, **22**: 354-360.
- Larson, R.A., K.S. Marley, R.W. Tuveson and M.R. Berenbaum (1988). β -Carboline alkaloids: mechanisms of phototoxicity to bacteria and insects. *Photochem. Photobiol.*, **48**: 665-674.
- Lydon, J., A.H. Teramura and C.B. Coffman (1987). UV-B radiation effects on photosynthesis, growth and cannabinoid production of two *Cannabis sativa* chemotypes. *Photochem. Photobiol.*, **46**: 201-206.
- Murali, N.S. and A.H. Teramura (1985). Effects of UV-B irradiance on soybean. VI. Influence of phosphorus nutrition on growth and flavonoid content. *Physiol. Plant.* **63**: 413-416.
- Prudot, A. and F.M. Basiouny (1982). Absorption and translocation of some growth regulators by tomato plants growing under UV-B radiation and their effects on fruit quality and yield. *Proc. Fla. State Hort. Soc.*, **95**: 374-376.
- Song, P.-S and K.J. Tapley, Jr. (1979). Photochemistry and photobiology of psoralens. *Photochem. Photobiol.*, **29**: 1177-1197.
- Specht, K.G. L. Kittler and W.R. Midden (1988). A new biological target of furanocoumarins: photochemical formation of covalent adducts with unsaturated fatty acids. *Photochem. Photobiol.*, **47**: 537-541.
- Sun, M. and S. Zigman (1979). Isolation and identification of tryptophan photoproducts from aqueous solutions of tryptophan exposed to near-UV light. *Photochem. Photobiol.*, **29**: 893-897.
- Teramura. A.H. (1983). Effects of ultraviolet-B radiation on the growth and yield of crop plants. *Physiol. Plant.*, **58**: 415-427.
- Teramura, A.H., R.H. Biggs and S. Kossuth (1980). Effects of ultraviolet-B irradiances on soybean. II Interaction between ultraviolet-B and photosynthetically active radiation on net photosynthesis, dark respiration, and transpiration. *Plant Physiol.*, **65**: 483-488.
- Tevini, M. and W. Iwanzik (1982). *Influence of enhanced UV-B irradiation on the growth and composition of plants*. Report GSF-BPY-1/82, Bereich Projekttraegerchaften, Ges. Strahlen- und Umweltforsch. m.b.H. Munchen, 189 pp.

- Tevini, M. and D. Steinmueller (1987). Influence of light, UV-B radiation, and wax biosynthesis of cucumber seedlings. *J. Plant Physiol.*, **131**: 111-121.
- Tevini, M., W. Iwanzik and A.H. Teramura (1983). Effects of UV-B radiation on plants during mild water stress. II Effects on growth, protein, and flavonoid content. *Z. Pflanzenphysiol.*, **110**: 459-467.
- Vu, C.V., L.H. Allen, Jr. and L.A. Garrard (1982). Effects of UV-B radiation (280-320 nm) on photosynthetic constituents and processes in expanding leaves of soybean (*Glycine max* [L.] Merr.). *Environ. Exp. Bot.*, **22**: 465-473.
- Zangerl, A.R. and M.R. Berenbaum (1987). Furanocoumarins in wild parsnip: effects of photosynthetically active radiation, ultraviolet light, and nutrients. *Ecology*, **68**: 516-520.

8.3 Photosensitization and Singlet Oxygen Toxicity

Thomas A. Dahl
 Department of Pharmacology
 Tufts University
 136 Harrison Ave.
 Boston, Massachusetts 02111

Photosensitization is a process in which light energy is captured by a chromophore and converted to chemical reactivity. The exact nature of the processes involved depend on both the sensitizer — for example the physical characteristics of its ground and excited states — and the immediate environment — for example the availability and characteristics of quenchers of sensitizer excited states. While some photosensitizers may display a preference for one or a small subset of pathways, almost all are capable of multiple modes of reactivity. This is particularly true in complex environments such as living systems. The principal modes of reactivity of excited state sensitizer are electron- and energy-transfer. Electron transfer pathways produce a host of radical species including the sensitizer radical itself, O_2^- , $\cdot OH$, $ROO\cdot$, $H\cdot$ and e_{aq}^- , as well as H_2O_2 . In these processes the excited state sensitizer may act as either a photoreductant or photooxidant. Energy-transfer pathways involve the quenching of excited state sensitizers by collision with molecules capable of accepting the excess energy. Transfer can take place between the excited singlet state of the sensitizer and ambient ground state singlet acceptor molecules. Alternatively, with sensitizers that undergo intersystem crossing (ISC; transition of multiplicity) to the excited triplet state, excitation energy may be transferred to ground state triplet oxygen to regenerate the ground state singlet sensitizer and excited state singlet oxygen.

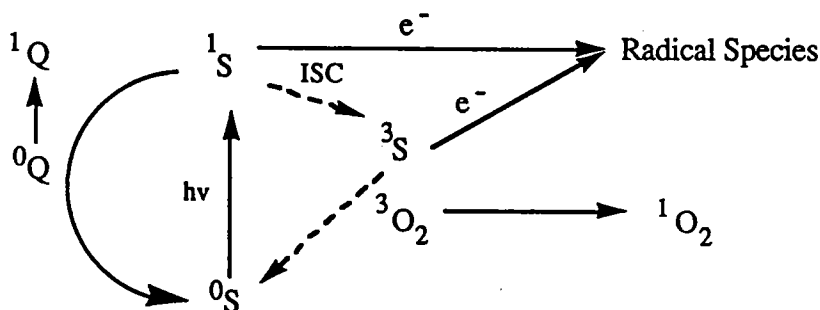

Because of the prevalence of molecular oxygen in air and surface waters, it is a common quencher in energy transfer reactions, particularly with sensitizers that exhibit significant triplet quantum yields and lifetimes. This transfer of energy between organic triplet states and O_2 takes place at near diffusion controlled rates. There are two low-lying singlet excited states for molecular oxygen, $^1\Delta_g$ and $^1\Sigma_g^+$, with excess energies of 22.5 kcal/mol (95 kJ/mol) and 37.5 kcal/mol (158 kJ/mol), respectively. Because the quenching constants for $^1\Delta_g O_2$ in virtually all environments are 5–6 orders of magnitude smaller than the corresponding values for $^1\Sigma_g^+ O_2$, only the $^1\Delta_g$ state will be important in environmental chemical and biological considerations. Thus the term “singlet oxygen”, commonly abbreviated as 1O_2 ,

generally refers to the $^1\Delta_g$ state, specifically. Because 1O_2 is the most common reactive intermediate formed by photosensitization with appropriate sensitizers under aerobic conditions, understanding the toxicity of 1O_2 is essential for understanding the toxicity of photosensitization.

Since most ground state molecules in nature have singlet configurations, the electronic configuration of 1O_2 is more suited to two-electron reactions than is the triplet ground state oxygen molecule. As a result, 1O_2 is more reactive than the ground state oxygen molecule with a wide variety of biologically and chemically important substrates. Singlet oxygen is an electrophile, and undergoes the characteristic reactions of cycloaddition and the "ene" reaction, principally, to form endoperoxides (usually unstable) and hydroperoxides. The substrate requirements for these reactions are conjugated double bonds (for cycloaddition) or an allylic hydrogen (for hydroperoxide formation). The presence of electron-donating groups can decrease the activation energies for both types of reaction. Additionally, dioxetanes can form from 1O_2 reaction with electron-rich unconjugated double bonds, and sulfhydryls react measurably with 1O_2 . These characteristics imply serious deleterious effects of 1O_2 reactions for living systems.

Histidine and some of its derivatives are among the most reactive biological substrates for 1O_2 known, through reaction with the imidazole ring. Other amino acids such as tryptophan, tyrosine, methionine and cysteine have been reported to react with 1O_2 . Small peptides are oxidized at about the same rate as their constituent reactive amino acids, while the same residues in larger proteins may be oxidized at the same rate (Matheson et al., 1975) or more slowly (Spikes and MacKnight, 1970), depending on accessibility of the residues to attack. Singlet oxygen reacts with unsaturated fatty acids, leading to the initiation or propagation of peroxidation reactions (Straight and Spikes, 1985). Nucleic acids and their components have been reported to react with 1O_2 ; in particular guanine and deoxyguanosine have demonstrated significant 1O_2 reactivities (Cadet et al., 1983; Midden and Wang, 1983; Kawanishi et al., 1986). These biological reactivities combine to make 1O_2 a surprisingly potent toxicant; in fact, 1O_2 is at least **10,000 times more toxic** than equimolar H_2O_2 in bacteria (Dahl et al., 1987). Plasma membranes, mitochondria, and nuclei have all been identified as vital targets in photodynamic action (killing of cells with light, sensitizer and O_2), ostensibly via 1O_2 mechanisms. Singlet oxygen interactions with membranes and membrane model systems have been reported to result in protein degradation, lipid peroxidation, and loss of membrane integrity (reviewed by Valezeno, 1987). Inhibition of mitochondrial function by 1O_2 could similarly result from protein and lipid damage, and the consequent disruption of the proton gradient required for respiration. Nuclear involvement in 1O_2 -mediated cytotoxicity has proved controversial. Singlet oxygen has been reported to react with some components of nucleic acids (above), and photosensitization has been reported to cause mutation and gene conversion (discussed more fully in Dahl et al., 1988). Bacterial studies with pure singlet oxygen have failed to provide any evidence for singlet oxygen mutagenicity or genotoxicity (Dahl et al., 1987; 1988). Nevertheless, some studies have provided chemical evidence for the reaction of pure singlet oxygen with DNA (Blazek et al., 1989; Di Mascio et al., 1989; Hildebrand, 1989), and mutagenicity or genotoxicity by photodynamic action in cultured cells (e.g., Ben-Hur et al., 1987).

A compilation of data from several sources using the same 1O_2 -generation system [that of Midden and Wang (1983) for the generation of "pure" 1O_2 , i.e. no competing non- 1O_2

reactions] yields the following relative rate constants for the reactions of various biomolecules with $^1\text{O}_2$.

Substrate	Relative Rate Constant ^a
histidine	1
deoxyguanosine	1/10-2/3 ^b
unsaturated fatty acids	1/2
ssDNA	1/120
dsDNA	1/1500

^aSources: Midden and Wang (1983); Di Mascio et al. (1989); Hildebrand (1989); unpublished data.

^bHighly pH-dependent; anionic form is much more reactive than the protonated form. This range represents pH values 7-9.

These figures are consistent with a model for $^1\text{O}_2$ cytotoxicity through plasma membrane (and intracellular membrane extensions, e.g., ER and Golgi) interactions, or other vital cellular targets rich in $^1\text{O}_2$ -reactive substrates. The relatively low $^1\text{O}_2$ -DNA reactivities may reflect poor accessibilities of reactive components, such as the guanine residues, and they also help explain the potent cytotoxicity without genotoxicity or mutagenicity of pure $^1\text{O}_2$ in bacterial studies (Dahl et al., 1987, 1988; Midden et al., 1987). Preliminary data with pure $^1\text{O}_2$ exposures of murine hepatocytes demonstrate the potent cytotoxicity of this toxicant in these mammalian cells; 90% killing was achieved with only 40% of the $^1\text{O}_2$ needed for the same response in gram-negative bacteria (unpublished data; see accompanying poster).

Because of its short lifetime (aqueous = 2 μs), $^1\text{O}_2$ has a limited diffusion radius (100-200 nm in pure water; Lindig and Rogers, 1981). Other reactive species generated from photosensitization have lifetimes just fractions of this. To be toxic, therefore, photosensitization processes must take place in close proximity to vital targets. There is a wide range of photosensitizers relevant to discussions of increased UV incidence in the biosphere, including plant sources (e.g., flavins, furocoumarins, components of essential oils), microbial (e.g., fungal extended quinones and bacterial pigments), ubiquitous endogenous cellular chromophores (e.g., tryptophan and its oxidation products, unsaturated fatty acids, riboflavin, and the various porphyrin-like molecules). In addition for man, sources include cosmetics and some medications, both topical and systemic. Increased UV irradiation of systems containing these sensitizers can lead to increased toxicity due to photosensitization. Although UV light does not generally penetrate tissues well, photosensitized toxicity will range from death (for microbes and small organisms) to reduced growth and productivity (in plants) to painful and disfiguring diseases (in larger animals, including man). Much of this toxicity may be mediated by the cellular interactions of increased $^1\text{O}_2$ exposure due to increased UV penetration to the biosphere. One global result may be the emergence of species with enhanced $^1\text{O}_2$ resistance.

References

- Ben-Hur, E., T. Fujihara, F. Suzuki and M.M. Elkind (1987). Genetic toxicology of the photosensitization of Chinese hamster ovary cells by phthalocyanines. *Photochem. Photobiol.*, **45**: 227-230.
- Blazek, E.R., J.G. Peak and M.J. Peak (1989). Singlet oxygen induces frank strand breaks as well as alkali- and piperidine-labile sites in supercoiled plasmid DNA. *Photochem. Photobiol.*, **49**: 607-613.
- Cadet, J., C. Decarroz, S.Y. Wang and W.R. Midden (1983). Mechanisms and products of photosensitized degradation of nucleic acids and related model compounds. *Israel J. Chem.*, **23**: 420-429.
- Dahl, T.A., W.R. Midden and P.E. Hartman (1987). Pure singlet oxygen cytotoxicity for bacteria. *Photochem. Photobiol.*, **46**: 345-352.
- Dahl, R.A., W.R. Midden and P.E. Hartman (1988). Pure exogenous singlet oxygen: Nonmutagenicity in bacteria. *Mutation Res.*, **201**: 127-136.
- Di Mascio, P., H. Wefers, H.-P. Do-Thi, M.V.M. Lafleur and H. Sies (1989). Singlet molecular oxygen causes loss of biological activity in plasmid and bacteriophage DNA and induces single-strand breaks. *Biochem. Biophys. Acta*, **1007**: 151-157.
- Hildebrand, E. (1989). *The reaction of externally-generated singlet oxygen with nucleic acids*. PhD Thesis, The Johns Hopkins University, Baltimore, Maryland.
- Lindig, B.A. and M.A.J. Rogers (1981). Rate parameters for the quenching of singlet oxygen by water-soluble and lipid-soluble substrates in aqueous and micellar systems. *Photochem. Photobiol.*, **33**: 627-634.
- Kawanishi, S., S. Inoue, S. Sano and H. Aiba (1986). Photodynamic guanine modification by hematoporphyrin is specific for single-stranded DNA with singlet oxygen as mediator. *J. Biol. Chem.*, **261**: 6090-6095.
- Matheson, I.B.C., R.D. Etheridge, N.R. Kratowich and J. Lee (1975). The quenching of singlet oxygen by amino acids and proteins. *Photochem. Photobiol.*, **21**: 165-171.
- Midden, W.R. and S.Y. Wang (1983). Singlet oxygen generation for solution kinetics: clean and simple. *J. Amer. Chem. Soc.*, **105**: 4129-4135.
- Midden, W.R., T.A. Dahl and P.E. Hartman (1987). Cytotoxicity but no mutagenicity in bacteria with externally generated singlet oxygen. In: *New Directions in Photodynamic Therapy*, D.C. Neckers (ed.), SPIE, Bellingham, Washington, pp. 122-126.
- Spikes, J.D. and M.L. MacKnight (1970). Dye-sensitized photooxidation of proteins. *Annals NY Acad. Sci.*, **171**: 149-162.
- Straight, R.C. and J.D. Spikes (1985). Photosensitized oxidation of biomolecules. In: *Singlet Oxygen*, A.A. Frimer (ed.), Ch. 2, Vol. VI, CRC Press, Boca Raton, Florida.

Valzeno, D.P. (1987). Photomodification of biological membranes with emphasis on singlet oxygen mechanisms. *Photochem. Photobiol.*, **46**: 147-160.

8.4 Bromoform Production by Marine Macroalgae; the Role of Vanadium Bromoperoxidases

R. Wever, B.E. Krenn, M.G.M. Tromp and G. Olafsson
E.C. Slater Institute for Biochemical Research
and Biotechnological Center
University of Amsterdam
Plantage Muidergracht 12
1018 TV Amsterdam
The Netherlands

It is well documented that marine brown (*Ascophyllum nodosum*, *Fucus vesiculosus*), red (*Gigartina stellata*) and green seaweeds (*Enteromorpha linza*, *Ulva lacta*) release large quantities of volatile brominated methanes like bromoform, dibromomethane and dibromochloromethane in the marine ecosystem (Gschwend et al., 1985). From the rate of release of the halometabolites by these lower plants (1–10 microgram bromine per gram of seaweed per day) and a global biomass of 10^{13} gram (Waaland, 1981), an annual global input in the biosphere of 10^4 tons per year is estimated. This is of the same order of magnitude as the reported anthropogenic input of organobromides (Gschwend et al., 1985). Thus these volatile halogenated compounds represent a substantial contribution to the halohydrocarbon burden in the atmosphere.

Recently, a group of vanadium containing bromoperoxidases has been discovered in brown seaweeds (*Ascophyllum nodosum*, and *Laminaria saccharina* (De Boer et al., 1986a, 1986b)) and in red seaweeds (*Corallina pilulifera* (Krenn et al., 1989a) and *Ceramium rubrum* (Krenn et al., 1987)). In the presence of hydrogen peroxide and bromide, these enzymes which have been characterized in detail, produce free hypobromous acid (HOBr and Br₂) in solution (De Boer and Wever, 1988). The bromoperoxidases are assumed to be involved in the biosynthesis of the volatile halogenated metabolites by bromination of nucleophilic acceptors. These acceptors are probably carboxy-methyl ketones, since halogenated ketones have been detected in seaweeds, and further it has been shown that bromination of ketones by a bromoperoxidase led to variety of halogenated ketones which decay via the classical haloform reaction to form the volatile brominated methanes (Theiler et al., 1978). The reason why these halometabolites are formed by the algae is not clear. However, these compounds have biocidal properties and they may simply form part of a defense system of the algae.

In the brown seaweed *A. nodosum* at least two different vanadium bromoperoxidases are found. One is located inside the thallus, particularly around the conceptacles, and the presence of this enzyme shows a seasonal variation (Wever, 1988; Vilter et al., 1983); maximal activity is found in winter and spring, when fruiting bodies are present, and a rapid decrease in activity is observed in the summer. Another bromoperoxidase is located at the thallus surface and can be considered to be extracellular (Krenn et al., 1989b). This location raises the possibility that some of these seaweeds also release free hypobromous acid and bromine to seawater. It is interesting to note that Gschwend et al. (1985) concluded that the brominated compounds are synthesized near the surface of the algae.

High levels of brominated organic species, of which bromoform is the main component (Berg et al., 1984), are found in the Arctic atmosphere. Measurements of atmospheric methylbromide and bromoform at Point Barrow, Alaska, show that the presence of these compounds is a function of the season; bromoform concentrations are maximal in winter and minimal in summer (Cicerone et al., 1988). The bromine content of Arctic aerosols at Point Barrow, Alert (Canadian Arctic) and Spitsbergen show an annual sharp maximum between February and May with concentrations which are the highest found anywhere in the world (Berg et al., 1983; Sturges and Barrie, 1988). There is substantial evidence that the source of the bromine containing particles and bromoform is biogenic and that they are formed in the oceans of the northern part of the northern hemisphere. Dyrssen and Fogelqvist (1981) showed that bromoform is present at all depths in the Arctic Ocean near Spitsbergen. The profile of depth versus concentration shows clearly that algal belts are responsible for the production of bromoform. However, macroalgae are probably not the only source of bromoform; phytoplankton may also contribute (Fogelqvist, 1985).

There is considerable interest in the formation of these compounds, in particular because Barrie et al. (1988) showed that, at polar sunrise, ozone destruction occurs in the lower Arctic atmosphere at Alert and that there was a strong correlation with the presence of filterable bromine in aerosols. Organobromides like bromoform are precursors of filterable bromine and bromoform is photochemically active (Barrie et al., 1988).

It is very likely that the vanadium bromoperoxidases present in seaweeds found in the Arctic Ocean are responsible for the observed annual maximal production of bromoform. Thus, we propose in line with Wever (1988) that the biological activity of these seaweeds is linked to the observed ozone destruction at ground level in the Arctic. This requires, however, that these vanadium enzymes are found in most macroalgae present in the Arctic Ocean. The vegetation in this ocean is dominated by two orders of brown seaweeds (*Laminariales* and *Fucales*). Indeed, we have been able to demonstrate that the brown seaweeds *Alaria esculenta*, *A. nodosum* and *Fucus distichus*, which were collected along the shores of Iceland, do contain such enzymes. Considering the amounts of volatile brominated compounds emitted by seaweeds, it is obvious that vanadium bromoperoxidases had and still have a large impact on chemical processes occurring in the atmosphere.

Reference

- Barrie, L.A., J.W. Bottenheim, R.C. Schnell, P.J. Crutzen and R.A. Rasmussen (1988). *Nature*, **334**: 138-141.
- Berg, W.W., P.D. Sperry, K.A. Rahn and E.S. Gladney (1983). *J. Geophys. Res.*, **88**: 6719-6736.
- Berg, W.W., L.E. Heidt, W. Pollock, P.D. Sperry and R.J. Cicerone (1984). *Geophys. Res. Lett.*, **11**: 429-432.
- Cicerone, R.J., L.E. Heidt and W.H. Pollock (1988). *J. Geophys. Res.*, **93**: 3745-3749.
- De Boer, E. and R. Wever (1988). *J. Biol. Chem.*, **263**: 12316-12332.
- De Boer, E., Y. Van Kooyk, M.G.M. Tromp, H. Plat and R. Wever (1986a). *Biochim. Biophys. Acta*, **869**: 48-53.

- De Boer, E., M.G.M. Tromp, H. Plat, B.E. Krenn and R. Wever (1986b). *Biochim. Biophys. Acta*, **872**: 104-115.
- Dyrssen, E. and E. Fogelqvist (1981). *Ocean. Acta*, **4**: 313-317.
- Fogelqvist, E. (1985). *J. Geophys. Res.*, **90**: 9181-9193.
- Gschwend, P.M., J.K. MacFarlane and K.A. Newman (1985). *Science*, **227**: 103-1036.
- Krenn, B.E., H. Plat and R. Wever (1987). *Biochim. Biophys. Acta*, **912**: 287-291.
- Krenn, B.E., Y. Izumi, H. Yamada and R. Wever (1989a). *Biochim. Biophys. Acta*, **998**: 63-68.
- Krenn, B.E., M.G.M. Tromp and R. Wever (1989b). *J. Biol. Chem.*, (in press).
- Sturges, W.T. and L.A. Barrie (1988). *Atmos. Env.*, **22**: 1179-1194.
- Theiler, R., J.C. Cook, L.P. Hager and J.F. Siuda (1978). *Science*, **202**: 1094-1096.
- Waaland, R.J. (1981). In: *The Biology of Seaweeds*, C.S. Lobban and M.J. Wynne (eds.), University of California Press, Berkeley and Los Angeles, pp. 726-741.
- Wever, R. (1988). *Nature*, **335**: 501.
- Vilter, H., K.-W. Glombitza and A. Grawe (1983). *Bot. Mar.*, **26**: 331-340.

8.5 Dimethylsulfide Production – Effects of UV-B and PAR on Heterogeneous Phytoplankton Populations

H. Gucinski¹, T.S. Bates², A.G. Wones¹ and M. Behrenfeld³

¹NSI Technology Services, Inc.
USEPA ERL
Corvallis, Oregon

²National Oceanic and Atmospheric Administration
Pacific Marine Environmental Laboratory
Seattle, Washington

³Department of General Sciences
Oregon State University
Corvallis, Oregon

Recent interest in feedback processes between global climate change and biospheric processes that drive emissions of radiatively important species has been spurred by recognition that oceanic production of DMS (dimethylsulfide) may provide an example of such a mechanism (Charlson et al., 1987). There have been challenges to this hypothesis (Caldeira, 1989; Schwartz, 1988, 1989; but see also Wigley, 1989) and one criterion that must be satisfied to establish a feedback mechanism is a clear effect of the outcome, in this case increased marine cloud production and reduced levels of PAR (photosynthetically active radiation) on the biological production of DMS. Moreover, the effect must outweigh simultaneous processes that offset this trend. A hypothetical example may be taken from the effects of solar UV-B (the 290 to 320 nm waveband). There is good evidence that UV-B suppresses primary productivity for many species of phytoplankton and heterogeneous populations (Worrest et al., 1978, 1981, 1983; Behrenfeld et al., 1989; Lorenzen, 1979; Smith and Baker, 1980), which if lowered production implies reduced evolution of DMS (Andreae, 1985; Bates and Cline, 1985), will act as a positive feedback to increasing levels of UV-B. Exposure of heterogeneous plankton populations to both ambient solar radiation and radiation enhanced with UV-B reduces DMS concentration in closed systems. Exposure to enhanced levels of UV-B appears to have little additional effect over exposure to ambient solar radiation (Figure 8.5.1), consistent with the findings of Brimblecombe and Shooter (1986) that photo-oxidation of DMS to DMSO (dimethylsulfoxide) under visible light appears to be promoted by photosensitizing agents including humic acids and can be rapid. No clear relationship between loss of DMS and dose of either PAR or UV-B enhanced radiation emerged from exposure of diverse populations, and the nearly linear relationship of DMS after exposure to initial concentration (Figure 8.5.2) suggests the absence of a photo-oxidizing threshold or a saturation effect over the range of exposures chosen. Coefficients of correlation are nearly identical for ambient and enhanced dosages ($r = 0.84$). Observation made over broad latitudes, from northern tropical Pacific waters to the edge of the Antarctic Ocean in the eastern Pacific (12°N to 58°S Latitude, 105° to 126°W Longitude) show positive correlation of DMS near surface concentrations with primary production only in waters between the equator and the northern edge of the central gyre (20°S Lat.). This finding is consistent with the findings of Andreae (1985) in the upwelling zone off Peru. As expected (Turner et al.,

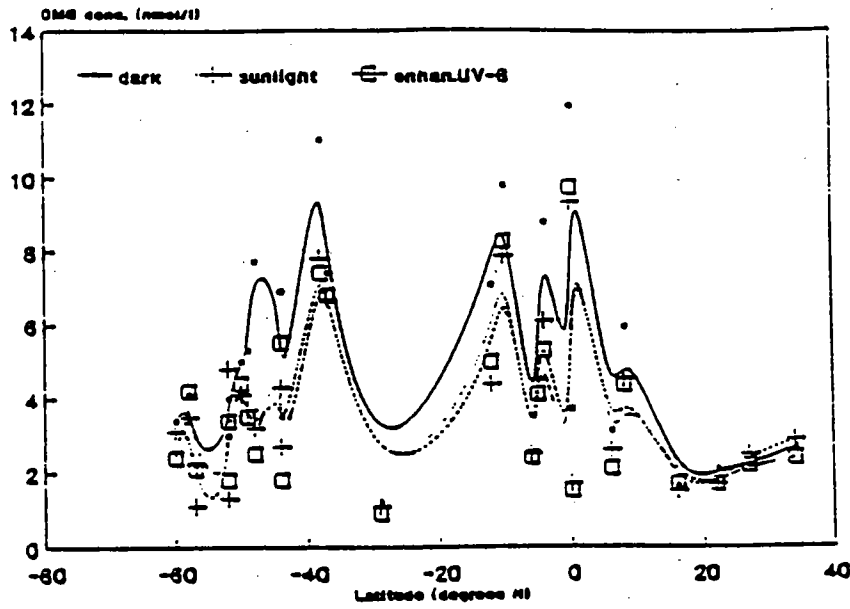

Figure 8.5.1: DMS incubation experiments.

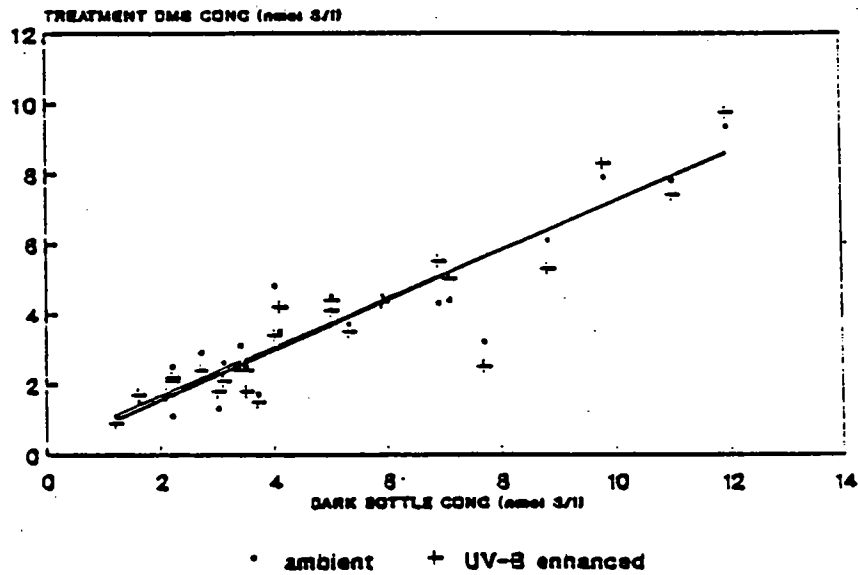

Figure 8.5.2: Treatment (DMS) vs. dark (DMS)

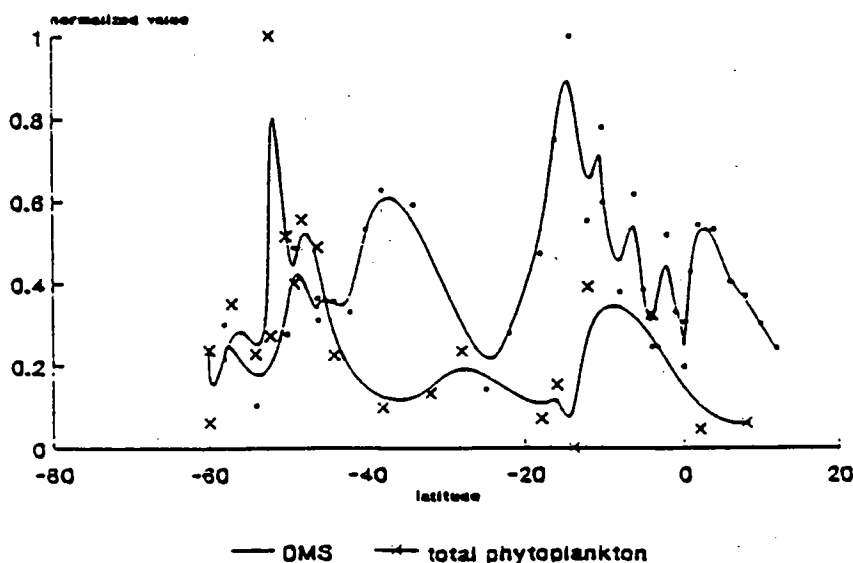

Figure 8.5.3: DMS and phytoplankton AITS 89 cruise.

1988) no clear correlation with chlorophyll concentrations were noted, which was also true to phaeophytin. The presence of coccolithophorids has been invoked to account for DMS (Andreae, 1980), but does not account for observed DMS concentrations in this transect. The typical subsurface maximum in DMS levels did not correlate with light penetration in either the PAR or UV-B bands. We don't understand, but deem noteworthy, the finding that DMS peaks (up to 13 nmol S l^{-1}) correlate well with minima in total phytoplankton density (Figure 8.5.3). This, and the relation of an anomalous peak in DMS in the central south Pacific gyre to low total phytoplankton, but dominance of small flagellates, tempts speculation that phytoplankton senescence and grazing pressure from zooplankton as described by Dacey and Wakeham (1986) accounts for observed concentration peaks, but must await confirming data. Our observations suggest that the biological and physical factors that drive the instantaneous DMS concentrations observed in these waters fall into three zones consistent with prior classification of marine biomes in these waters (Hayden et al., 1984). We see the need for controlled process studies to determine the equivalent of an action spectrum for light in both the visible and UV-A and B portions of the spectrum, and the need for additional work on the variables that drive DMS production and breakdown, especially the production of DMSO in the water column and its ultimate fate before flux predictions can be made from ecosystems processes.

References

- Bates, T.S. and J.D. Cline (1985). The role of the ocean in a regional sulfur cycle. *J. Geophys. Res.*, **90**(C5): 9168-9172.

- Behrenfeld, M. (1989). *Primary productivity in the southeast Pacific: effect of enhanced ultraviolet-B radiation*. M.S. Thesis, Dept. General Science, Oregon State University.
- Brimblecombe, P. and D. Shooter (1986). Photo-oxidation of dimethylsulphide in aqueous solution. *Mar. Chem.*, **19**: 343-353.
- Caldeira, K. (1989). Evolutionary pressures on planktonic production of atmospheric sulfur. *Nature*, **337**: 732-734.
- Charlson, R.J., J.E. Lovelock, M.O. Andreae and S.G. Warren (1987). Oceanic phytoplankton, atmospheric sulphur, cloud albedo, and climate. *Nature*, **326**: 655-661.
- Dacey, J.W.H. and S.G. Wakeham (1986). Oceanic dimethylsulfide: production during zooplankton grazing on phytoplankton. *Science*, **233**: 1314-1316.
- Hayden, B.P., G.C. Ray and R. Dolan (1984). Classification of coastal and marine environments. *Environ. Cons.*, **11**(3): 199-207.
- Iverson, R.L., F.L. Nearhoof and M.O. Andreae (1989). Production of dimethylsulfonium propionate and dimethylsulfide by phytoplankton in estuarine and coastal waters. *Limnol. Oceanogr.*, **34**(1): 53-67.
- Lorenzen, C.J. (1979). Ultraviolet radiation and phytoplankton photosynthesis. *Limnol. Oceanogr.*, **24**(6): 11177-11120.
- Schwartz, S.E. (1988). Are global albedo and climate controlled by marine plankton? *Nature*, **336**: 441-445.
- Smith, R.C. and K.S. Baker (1980). Stratospheric ozone, middle-ultraviolet radiation and carbon-14 measurements of marine productivity. *Science*, **208**: 592-593.
- Wigley, T.M.L. (1989). Possible climate change due to SO₂-derived cloud condensation nuclei. *Nature*, **339**: 365-367.
- Worrest, R.C., H. Van Dyke and B.E. Thomson (1978). Impact of enhanced simulated solar ultraviolet radiation upon a marine community. *Photochem. Photobiol.*, **17**: 471-478.
- Worrest, R.C., B.E. Thomson and H. Van Dyke (1981). Impact of UV-B radiation upon estuarine microcosms. *Photochem. Photobiol.*, **33**: 861-867.
- Worrest, R.C. (1983). Impact of solar UV-B radiation (290-320 nm) upon marine microalgae. *Physiol. Plant.*, **58**: 428-434.

8.6 Impact of UV-B (290–320 nm) Radiation on Metabolic Processes of Marine Phytoplankton

G. Döhler

Botanisches Institut der Universität

Siesmayerstraße 70

D-6000 Frankfurt am Main

Federal Republic of Germany

A depletion of the stratospheric ozone layer by chemical insertion may result in an enhancement of the ambient solar UV radiation on the earth's surface. It is well known that ultraviolet-B irradiance can damage the biological ecosystems. Pigmentation, photosynthesis, biomass production and other metabolic processes, as well as the community composition of the aquatic ecosystem, are affected by UV-B radiation (Döhler, 1985, 1988; Iwanzik et al., 1983; Smith et al., 1980; Worrest, 1982 and references therein). Recently, the nitrogen metabolism of phytoplankton species was investigated under ultraviolet irradiance too.

The impact of UV-B on growth, cell components and metabolic processes of pure cultures of microalgae and natural phytoplankton was studied in more detail. Several marine diatoms isolated from the North and Baltic Sea as well as from Antarctica (Weddell Sea) grown under laboratory conditions (0.035 vol.% CO₂, light/dark regime of 14:10 or 6.5:17.5 h, + 18°C or 5°C) and natural phytoplankton were exposed to UV-B radiation (Philips lamps TL 40/12, cut-off filters WG 305, 3 mm thickness). The different doses were obtained by changing the distance from the UV lamps to the vessels or by variation of the exposure time. ¹⁴C experiments and separation of ¹⁴C labelled products were carried out after the methods described by Döhler (1972). The Dumas method has been used for preparation of the ¹⁵N samples; ¹⁵N analysis was performed with an atomic emission spectrometer (Station NOI-5, Zeiss, Jena). For further details see Döhler and Roßlenbroich (1981).

Several microalgae (*Chlorella*, *Porphyridium*, marine diatoms) exposed to UV-B showed plasmolysis and a reduction of protein and pigment content (chlorophyll, biliproteins). Low doses of UV-B radiation had no or an enhancement effect on biomass production (dry weight). However, growth and synchronization of the marine diatoms *Didylum* and *Synedra* were markedly affected by very low UV-B doses (100 J m⁻²). An alteration in the generation time of the phytoplankton caused by ambient solar UV might have an important influence on the primary consumer in the nutrient chain. The amount of acyl lipids and fatty acids of synchronized *Didylum* was reduced by UV-B radiation of the cells, digalactosyl diacylglycerol especially. A damage of the DNA and RNA synthesis could be reactivated within 2 further division cycles of *Didylum* while a stage-dependent effect of UV-B radiation on the lipid and fatty acid biosynthesis was found.

Enhanced levels of UV-B caused a depression of the photosynthetic ¹⁴CO₂ fixation of several tested microorganisms. It could be shown that the carbon metabolism was less affected by UV-B stress than the uptake and assimilation of inorganic nitrogen compounds. Short-term experiments demonstrated that no influence on the pattern of ¹⁴C-labelled photosynthetic products exists whereas the ¹⁵N incorporation into the free amino acids was significantly changed during ultraviolet irradiance. Uptake of ¹⁴N-ammonia was more dam-

aged by UV-B than utilization of ^{15}N -nitrate, independent of the tested species and natural phytoplankton from temperate regions or Antarctica. A species-dependent sensibility to UV-B radiation could be found by determination of the uptake of ammonia and nitrate as well as of the pool sizes of free amino acids. UV-B radiation led to a variation in the pattern of ^{15}N -incorporation into the free amino acids of *Lauderia* and had an inhibitory effect on the protein synthesis, too. Generally, pool size and ^{15}N -incorporation into glutamine increased after UV-B exposure. UV-B irradiance ($800 \text{ J m}^{-2}\text{d}^{-1}$) in connection with monochromatic light resulted in a different behaviour: uptake rates of inorganic nitrogen by *Thalassiosira* were reduced in blue, orange and red light, whereas an increase has been observed in green and orange red light. Pattern of proteins and *in vitro* translation products of isolated poly A RNA of *Odontella* varied after UV-B irradiance: a protein (43 KD) was found after UV-B stress. Activities of key enzymes of the carbon and nitrogen metabolism were differently affected by UV-B: nitrate reductase, alanine aminotransferase and ribulosebisphosphate carboxylase are the most sensitive enzymes, whereas glutamate dehydrogenase, glutamate synthase, aspartate aminotransferase and phosphoenolpyruvate carboxylase showed a slight inhibition; however, the activity of glutamine synthetase increased after UV-B exposure. In conclusion of our results, UV-B radiation results in an influence on the regulation of metabolic processes and leads to a variation in the community composition.

References

- Döhler, G. (1972). *Planta (Berl.)*, **107**: 33–42.
- Döhler, G. (1985). *J. Plant Physiol.*, **118**: 391–400.
- Döhler, G. and H.-J. Roßlenbroich (1981). *Z. Naturforsch.*, **36**: 834–839.
- Iwanzik, W., M. Tevini, G. Dohnt, M. Voss, W. Weiss, P. Gräber and G. Renger (1983). *Physiol. Plantarum*, **58**: 401–407.
- Smith, R.C., K.S. Baker, O. Holm-Hansen and R. Olson (1980). *Photochem. Photobiol.*, **31**: 585–592.
- Worrest, R.C. (1982). In: *The Role of Solar Ultraviolet Radiation in Marine Ecosystems*, J. Calkins (ed.), Plenum Press, New York, pp. 429–457.

8.7 Ultraviolet Radiation in Antarctic Waters: Particulate Absorption and Effects on Photosynthesis

B.G. Mitchell, M. Vernet and O. Holm-Hansen
Polar Research Program, A-002
Scripps Institution of Oceanography
University of California, San Diego
La Jolla, California 92093

Knowledge of the penetration of ultraviolet (UV) radiation flux into the water column in the Antarctic is essential for assessment of the significance of reduced ozone in the atmosphere on marine primary production. In the vicinity of Palmer Station, we studied variability in the spectral absorption of marine particulates, penetration of UV radiation into the water column and the spectral aspects of UV photoinhibition of phytoplankton.

Methods described by Mitchell and Kiefer (1988) were used to determine spectra from 300–700 nm for absorption coefficients of marine particulates (a_p). We also made detailed studies of *in situ* optical properties using a multi-channel biological-optical-physical profiling system deployed from R/V POLAR DUKE. *In situ* optical measurements included the diffuse attenuation coefficients (k) in the visible and at a band centered at 320 nm in the UV.

We hypothesized that Antarctic marine particulates in general, and phytoplankton specifically, may contain UV absorbing compounds which attenuate UV radiation. UV absorbing compounds have been noted in phytoplankton (Vernet et al., 1989) and corals (Dunlap et al., 1986), and if present in Antarctic phytoplankton, may provide some measure of natural protection from damaging UV radiation. We found that intact marine particulates contain a UV absorption peak between 320 and 340 nm which can be up to five times higher than the peak absorption in the visible close to 440 nm (Figure 8.7.1). This absorption band was not always prominent as indicated in the figure. In general, the ratio of $a_p(330)/a_p(675)$ (peak UV and chlorophyll *a* absorption bands) was highest in surface waters. Other carotenoids known to serve a photoprotective role were also highest in surface waters.

The strong UV absorption by particulates is expected to play an important role in the diffuse attenuation coefficient for UV irradiance. Using selective filters to screen different portions of the natural UV spectrum from *in situ* primary production vessels, we observed no effects of natural levels of UV at depths greater than 20 m. As much as 50% UV photoinhibition of primary production at 1 m was observed.

We document strong absorption in the UV from 320–330 nm for marine particulates. Below this region of the solar energy spectrum, absolute energy levels drop off very dramatically. Only wavelengths shorter than about 320 nm will be significantly enhanced due to ozone depletion. If the absorption we observed serves a protective role for phytoplankton photosynthesis, it appears the peak band is in the region where solar energy increases rapidly, and not in the region where ozone depletion would cause significant variations in absolute flux. Results on the spectral response of UV inhibition of photosynthesis from natural solar energy indicate that wavelengths from 320–335 provide the greatest absolute photoinhibitory effect. It is not known if there is a relationship between short-term photosynthetic inhibition and phytoplankton survival or genetic damage.

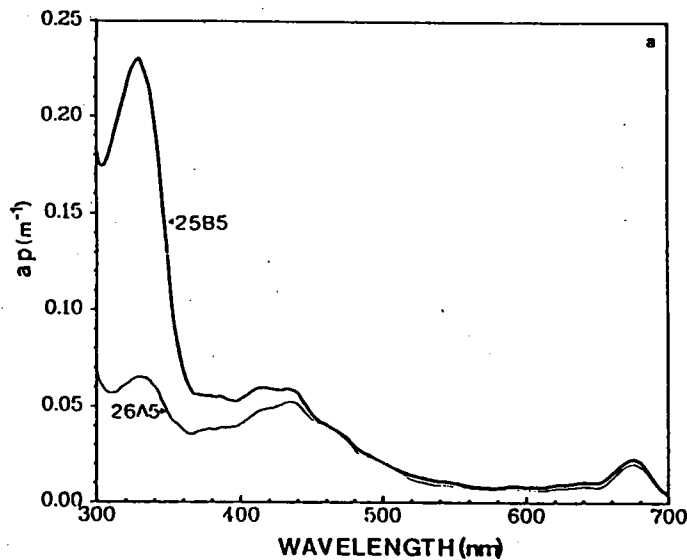

Figure 8.7.1: The spectral absorption coefficient of marine particulates ($a_p \text{ m}^{-1}$) from 300–700 nm for a station with a high $a_p(330)$ and a low $a_p(330)$ relative to the absorption of photosynthetic pigments from 400–700 nm. Station 25B was located at 64.6°W , 65.9°S , station 26A located at 64.9°W , 64.3°S . Both samples were from 5 m depth in the upper mixed layer. Values of chlorophyll a for the two samples were similar, in agreement with the similar magnitude of $a_p(675)$ in the red absorption maximum for chlorophyll a.

Acknowledgment: This work was supported by National Science Foundation grant DPP 88-10462.

References

- Dunlap, W.C., B.E. Chalker and J.K. Oliver (1986). Bathymetric adaptations of reef-building corals at Davies Reef, Great Barrier Reef, Australia. III. UV-B absorbing compounds. *J. Experimental Mar. Biol. Ecol.*, **104**: 239–248.
- Mitchell, B.G. and D.A. Kiefer (1988). Chlorophyll a specific absorption and fluorescence excitation spectra for light-limited phytoplankton. *Deep-Sea Res.*, **35**(5): 639–663.
- Vernet, M., A. Neori and F.T. Haxo (1989). Spectral properties and photosynthetic action in red-tide populations of *Prorocentrum micans* and *Gonyaulax polyedra*. *Mar. Biol.*, (in press).

8.8 Ecological Considerations of the Antarctic Ozone Hole in the Marine Environment

Deneb Karentz
Laboratory of Radiobiology and Environmental Health
University of California
San Francisco, California 94143-0750

Springtime ozone depletion over Antarctica has resulted in increased incident UV-B. The effect on Antarctic species and the extent of ecosystem modification caused by ozone holes is unknown. However, certain physical features of Antarctic environments and inherent traits of endemic species may be minimizing the ecological impact of increased UV-B levels.

The Ozone Hole and Incident UV-B in Antarctica

The ozone hole was first observed in 1978 and has become a predictable event in the springtime atmosphere over Antarctica. Ozone depletion occurs within the polar vortex and is sustained for at least several weeks. The hole disappears when the polar vortex dissipates and ozone concentrations equilibrate with surrounding air masses. The extent of ozone depletion and the area of the depletion zone vary from year to year.

Radiative transfer models have indicated that springtime levels of incident UV-B under the ozone hole are comparable to midsummer intensities that are filtered through a normal ozone column (Frederick and Snell, 1988; Lubin et al., 1989). Actual measurements of incident UV irradiances in Antarctica were not made until 1988 and both elevated UV-B intensities and increased ratios of UV-B to UV-A have been recorded.

General Aspects of UV-B Photobiology

The biological effects of UV-B are strongly wavelength dependent, even within a range of a few nanometers. Small changes in ozone concentration result in disproportionate changes in the biological harmfulness of ground-level UV-B. Direct mutagenic and lethal effects of UV exposure occur from damage to DNA and there are three known cellular repair mechanisms: photoreactivation, excision repair and recombination repair. In addition to genetic damage, inhibitory effects of UV exposure are related to absorption by RNA, proteins and other biological molecules. The degree of UV sensitivity exhibited by an organism is related to the number and efficiency of repair systems as well as the existence of avoidance strategies (behavior modification and physical protection from UV exposure).

Environmental Factors That Can Affect UV Exposure in Antarctica

Clouds: During much of the year, skies over Antarctica and adjacent coastal areas are overcast. The average number of cloudy days per month at Palmer Station is approximately 26 and at McMurdo Station 20. Cloud cover serves to mitigate the impact of UV stress on Antarctic communities by reducing radiation intensity, but has little effect on spectral quality (Lubin et al., 1989).

Snow: During spring when ozone levels are at their lowest, coastal areas and sea ice can be covered by several centimeters to several meters of snow. Although white light is transmitted through snow layers and can support a low level of photosynthesis (Curl et al., 1972), UV wavelengths are rapidly attenuated.

Ice: The Southern Ocean accounts for 10% of the world's ocean area, 18% is permanently covered by glacial ice sheets and an additional 55% can be covered by sea ice at the end of winter (Foster, 1984). Various sized fractures can occur in the ice pack, ranging from leads of 1-10 km in width to polynyas that can encompass thousands of square km (Gordon and Comiso, 1988), resulting in large areas of the ocean surface being exposed to direct solar radiation during the presence of the ozone hole.

Under 1-2 m of ice the euphotic (visible light) zone can extend to at least 3 m (Palmisano et al., 1986). Actual measurements of UV intensity and spectral distributions have not been made under the ice. Scattering and absorption of visible light by sea ice is a function of albedo, salinity and the vertical structure of the ice layer (Weller, 1969; Trodahl et al., 1989). The spectral distribution and intensity of light reaching the water column is further modified by ice communities. Mathematical modeling of UV light transmission through sea ice suggests that the physical characteristics of new ice during early spring enhance the transmission of UV wavelengths relative to older ice that is more turbid (Trodahl and Buckley, 1989).

Water Column: Few actual measurements of in-water UV spectral intensities have been made in marine systems (Smith and Baker, 1979, and others) and most estimates of UV penetration have been calculated through the use of various mathematical models that require inputs of incident radiation and various hydrographic parameters (Zaneveld, 1975; Smith and Tyler, 1976). In addition to hydrographic factors that affect UV transmission, mixing processes will control actual doses received by planktonic organisms. There is no information on simultaneous rates of damage and repair in natural systems. Most laboratory experiments on UV photobiology are not suitable for transfer into a field situation and measurement of photoproduct formation and repair under ambient light conditions has not been attempted.

Biological Research Related to Antarctic Ozone Depletion

Field research undertaken at Palmer Station in 1987 and 1988 focused on three major areas:

1. **Transmission of biologically active UV-B.** The transmission of biologically active UV-B wavelengths was monitored in coastal waters using a biological dosimeter system. Results indicated that during the ozone hole, biologically active wavelengths of UV-B consistently penetrated to depths of 10 m and could reach 20 m.
2. **DNA repair mechanisms and relative dose responses.** Photoreactivation is the primary means of correcting UV-induced DNA damage in bacteria and phytoplankton species. These organisms also exhibited a wide range of species-specific UV sensitivity.

3. **UV-absorbing compounds.** Antarctic invertebrates and algae contain UV-absorbing mycosporine amino acids identical to those of tropical and temperate marine species (Dunlap et al., 1988). These compounds absorb in the UV-B region of the spectrum and may act as natural sunscreens, protecting internal organs and/or organelles from excessive exposure to UV-B.

Conclusions

Interspecific differences in ability to cope with UV are perhaps the most crucial factor in assessing the ecological implications of ozone depletion at any latitude. Increased UV-B will result in shifts in the taxonomic structure of the community and reduction in net productivity (Worrest et al., 1978). Modifications of this type affect food availability and nutritional value, altering the transfer of energy between trophic levels. The ozone hole has been recurring now for over a decade and we can expect this phenomenon to continue as an annual event. Any biological, and subsequent ecological, effects that will result from this have already been initiated; but we do not have sufficient information to assess the effects of past ozone holes. In order to evaluate the ecological impact of continued springtime UV-B stress on species associations and trophic interactions, research efforts need to focus on quantification of UV exposure (as modified by the Antarctic environment) and on the UV-photobiology of individual species.

This work was supported by NSF grant DPP 87-125333; Office of Health and Environmental Research, Dept. of Energy contract DE-AC03-76-SF01012; and an award from the Australian Institute of Marine Science.

References

- Curl, H., Jr., J.T. Hardy and R. Ellermeier (1972). Spectral absorption of solar radiation in alpine snow fields. *Ecology*, **53**: 1190-1194.
- Dunlap, W.C., B.E. Chalker and W.M. Bandaranayake (1988). New suncreening agents derived from tropical marine organisms of the Great Barrier Reef Australia. *Proceedings of the 6th International Coral Reef Symposium*.
- Foster, T.D. (1984). The marine environment. *Antarctic Ecol.*, **2**: 345-371.
- Frederick, J.E. and H.E. Snell (1988). Ultraviolet radiation levels during the Antarctic spring. *Science*, 438-440.
- Gordon, A.L. and J.C. Comiso (1988). Polynyas in the Southern Ocean. *Sci. Amer.*, **258**: 90-97.
- Lubin, D., J.E. Frederick, C.R. Booth, T. Lucas and D. Neuschuler (1989). Measurements of enhanced springtime ultraviolet radiation at Palmer Station, Antarctica. *Geophys. Res. Lett.*, **16**: 783-785.
- Palmisano, A.C., J.B. SooHoo, S.L. SooHoo, S.T. Kottmeier, L.L. Craft and C.W. Sullivan (1986). Photoadaptation in *Phaeocystis pouchetii* advected beneath annual sea ice in McMurdo Sound Antarctica. *J. Plankton Res.*, **8**: 891-906.

- Smith, R.C. and K.S. Baker (1979). Penetration of UV-B and biologically effective dose-rates in natural waters. *Photochem. Photobiol.*, **29**: 311-323.
- Smith, R.C. and J.E. Tyler (1976). Transmission of solar radiation into natural waters. In: *Photochemical and Photobiological Reviews*, K.C. Smith (ed.), Plenum Press, New York, vol. 1, pp. 117-155.
- Trodahl, H.J. and R.G. Buckley (1989). Ultraviolet levels under sea ice during the Antarctic spring. *Science*, **245**: 194-195.
- Trodahl, H.J., R.G. Buckley and M. Vignaux (1989). Anisotropic light irradiance in and under sea ice. *Cold Reg. Sci. Technol.*, **16** (in press).
- Weller, G.E. (1969). Radiation diffusion in Antarctic ice media. *Nature*, **221**: 355-356.
- Worrest, R.C., H. van Dyke and B.E. Thomson (1978). Impact of enhanced simulated solar ultraviolet radiation upon a marine community. *Photochem. Photobiol.*, **27**: 471-478.
- Zaneveld, J.R.V. (1975). Penetration of ultraviolet radiation into natural waters. In: *Impacts of Climatic Change on the Biosphere. C.I.A.P. Monograph 5, Pt. I - Ultraviolet Radiation Effects*, D.S. Natchwey, M.M. Caldwell and R.H. Biggs (eds.), Dept. Transp. Climatic Assessment Prog., pp. 2-108-2-157.

8.9 Potential Effects of Solar Ultraviolet Radiation on Antarctic Phytoplankton

S.Z. El-Sayed¹, F.C. Stephens², R.R. Bidigare¹ and M.E. Ondrusek¹

¹Department of Oceanography
Texas A&M University
College Station, Texas 77843

²Naval Oceanographic Research and Development Activity
Stennis Space Center
Bay St. Louis, Mississippi 39529

Stratospheric ozone shields the earth from much of the solar middle ultraviolet radiation (UV-B, 290–320 nm waveband), which is the most biologically injurious component of sunlight. Recent reports on the “ozone hole” over Antarctica have renewed concern about the consequences of increased levels of UV-B reaching the earth’s biosphere. One area of concern involves phytoplankton which constitutes the base of the food web in aquatic ecosystems. Numerous studies have shown that increased levels of UV exposure result in reduced primary production. Additionally, increases in UV-B levels are likely to alter community diversity and species composition. By weakening the base of the food web and altering trophodynamic relationships, UV-induced changes could potentially have far-reaching effects on the entire Southern Ocean ecosystem.

The potential significance of the annual thinning of the ozone layer over the Antarctic continent during the austral spring from September through October is recognized. To examine the effects of this thinning, we undertook an investigation into the effects of UV-B on Antarctic phytoplankton and ice-algae collected from Arthur Harbor, Antarctica and vicinity. The main objective of this study was to document the effects of UV on primary production and on photosynthetic pigmentation of phytoplankton in Arthur Harbor. Three parameters were studied: (1) primary production rates, (2) photosynthetic pigments, and (3) photosynthesis-irradiance responses. These parameters were monitored during short-term and relatively long-term exposures to varying levels of UV radiation.

The response of the phytoplankton communities in the water samples to varying levels of UV radiation was studied by using a specially designed array of tanks and chambers. The tanks/chambers, which were kept outdoors under natural light conditions, were subjected to varied irradiation treatments. The tanks and chambers were constructed of either UV-absorbing or UV-transmitting plexiglas depending on whether the object was to eliminate, reduce, or enhance UV-radiation levels. The “unweighted” enhanced UV radiation (290–320 nm) was about 16 percent relative to ambient UV.

The results of the month-long study provided insight into the potential deleterious effects of enhanced UV radiation. These results showed an enhancement of primary production rates (by 200–400 percent) in the tank where UV-A and UV-B were excluded. Conversely, rates of production were much lower under enhanced UV conditions.

Despite the preliminary nature of the results of this study, there is sufficient evidence to implicate elevated UV-B radiation contributing to: (1) reduced rates of photosynthesis,

and (2) changes in photosynthetic pigmentation. Further research is required to determine if these findings can be applied to the phytoplankton and ice-algae of the Southern Ocean.

Considerable caution must be exercised in extending the results of these short-term laboratory experiments to the "real world." In the latter case, one has to contend with a host of very complex interrelated factors including the diffuse attenuation coefficient for UV radiation, depth of the mixed-layer, residence time of the algal cells in the euphotic zone, seasonality of exposure, behavioral responses of the targeted organisms, and their tolerance to and avoidance of solar UV, and their capabilities to repair UV-impaired DNA molecules. As to whether the effect of UV-B on the algal population is short-lived, long-lasting or reversible, this is impossible to answer from the limited data we have.

The implications of these findings to the ecology of the Southern Ocean could be far-reaching. Based on the results of the Palmer Station experiments, and given the long lifetime of man-made chlorofluorocarbons (CFCS), the impact of elevated UV-B could be long-lasting and potentially damaging.

Since the phytoplankton are the basic primary producers in the Antarctic Ocean on which all other components of the ecosystem (zooplankton, krill, fish, squid, winged birds, penguins, seals and whales) depend for their livelihood, any substantial decrease in the productivity of these waters, or any change in their community structure, could have far-reaching ecological implications.

9 Presented in Absentia

9.1 Ozone Depletion and Greenhouse Warming

Alex E.S. Green
Interdisciplinary Center for Aeronomy
and Other Atmospheric Sciences
Clean Combustion Technology Laboratory
Mechanical Engineering
University of Florida
Gainesville, Florida 32611

The interactions of the oxides of nitrogen with atmospheric ozone was first recognized in connection with photochemical smog in the 40's in connection with high altitude nuclear explosions and other military issues in the 50's and early 60's (Green, 1962) and as a possible problem with a supersonic transport (SST) fleet in the late 60's. Stratospheric ozone's role in attenuating the solar middle ultraviolet reaching the ground and backscattered to space (Green, 1966) became important in the last connection. Concern as to carcinogenic impact of stratospheric ozone depletion due to an SST fleet was first articulated by MacDonald (1971), who estimated that a 1% depletion of stratospheric ozone would cause a 6% increase in skin cancer. Our knowledge of stratospheric ozone depletion mechanisms, increases in ultraviolet radiation reaching the ground and biological impacts was greatly broadened by the Climatic Impact Assessment Program (CIAP) in the early 70's (Grobeck et al., 1974). The destruction of stratospheric ozone by chlorine was first noted by Stolarski and Cicerone (1974) in connection with a study of the environmental impact of gaseous emissions from solid rockets. The identification by Roland and Molino (1975) of the chlorofluorocarbons (CFC's) photolytically dissociated by the harder ultraviolet reaching the upper atmosphere as a source of stratospheric chlorine then led to a great increase in public concern about stratospheric ozone.

Concern for the ozone layer has risen and fallen several times since 1974, but the discovery in 1985 of the Antarctic ozone hole (Farman et al., 1985) and subsequent scientific investigations (Stolarski et al., 1986; Krueger et al., 1988) has led to the Montreal Protocol, an international agreement to control global emissions of CFC's. The stratospheric ozone depletion problem which represents the first anthropogenic emissions problem seriously addressed by the international community affords hope that other anthropogenic emissions problems might also be addressed. Figure 9.1.1 gives a broad overview of anthropogenic emission problems (Green, 1989).

Carbon dioxide emissions from fossil fuel burning have conventionally been viewed as the primary cause of global warming. Since fossil fuels are now mankind's major source of energy, it will probably be more difficult to reach international agreement on the greenhouse issue than on the stratospheric ozone issue. However, recent studies (Wubbles, 1989) have indicated that anthropogenic emissions of CH₄, N₂O, NH₃ and particularly CFC's will soon contribute as much to greenhouse warming as CO₂ emissions. These greenhouse involvements are illustrated in Figure 9.1.2 which presents information on the earth-atmosphere blackbody emissions, the absorption coefficients of trace greenhouse gases and liquid wa-



ANTHROPOGENIC EMISSIONS TO ATMOSPHERE

Transportation, Utilities, Industrial, Commercial,
Residential, Landfills, Incineration, Agricultural

SOURCES

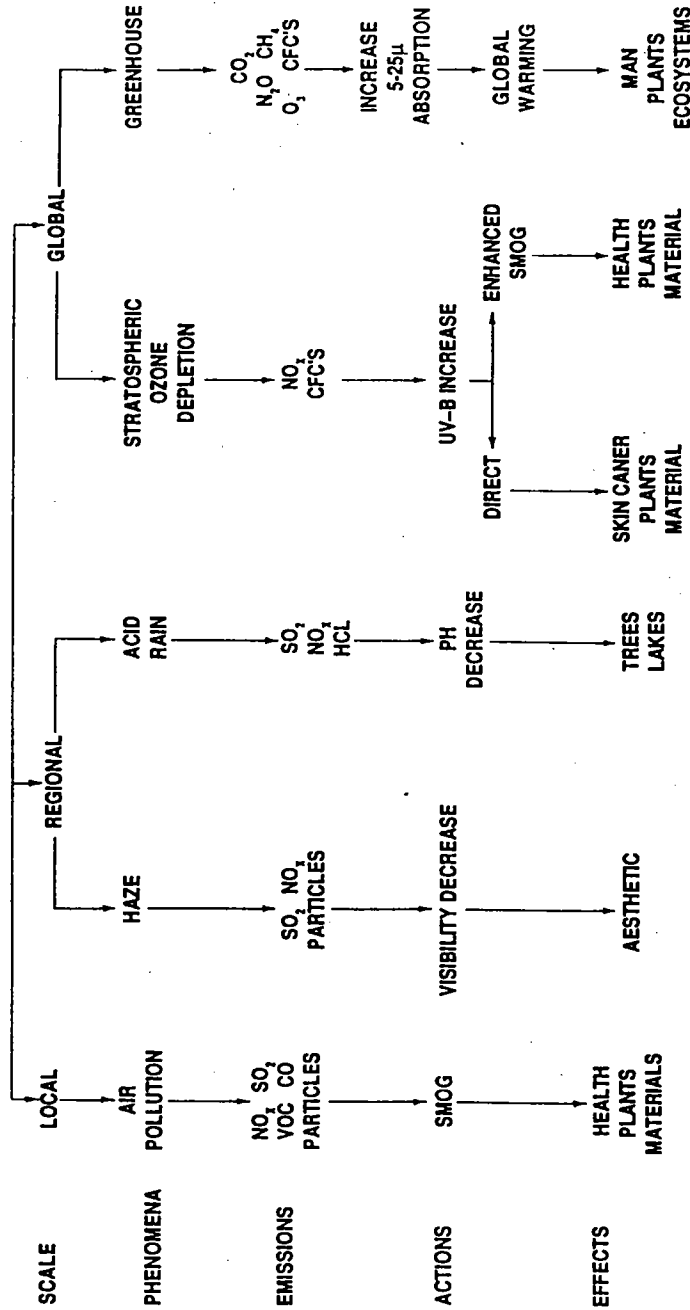

A LITTLE KNOWLEDGE IS A DANGEROUS THING, DRINK DEEP OR TASTE NOT THE PIERIAN SPRING: Alexander Pope

AESG-89

Figure 9.1.1: Anthropogenic emission problems to atmosphere. Adapted from Green (1989).

ter and the band strengths of CRC's (Ramanathan et al., 1987) in the longwave region of importance to global warming (Green, 1989).

Within the earth's longwave atmospheric window anthropogenic emissions particularly halogenated hydrocarbons have band intensities many thousand times greater than the 10 micron CO₂ band and hence are far more effective greenhouse gases than CO₂. It is ironic that several of the halogenated hydrocarbon substitutes for F11 and F12 developed to mitigate the ozone depletion problem might exacerbate the greenhouse problem. Solid halogenated hydrocarbon plastics developed for pipes, insulators, waterproofing, packaging and other purposes, when photodegraded, biodegraded or incinerated can also produce ozone depleting or greenhouse gases.

After 50 years experience with a variety of anthropogenic atmospheric problems mankind has begun to identify and understand the detailed scientific mechanisms involved. Local "smog" problems are already being addressed in the United States at the state and national level. However, clearly, the time has come to use our knowledge to develop practical national and international measures to minimize the impact of regional and global emission problems.

References

- Farman, J.C., B.G. Gardiner and J.D. Shanklen (1985). *Nature*, **315**: 207.
- Green, A.E.S. (ed.) (1962). *The Middle Ultraviolet and its Space Applications*, ERR-AN-185, Space Sciences Laboratory, Convair General Dynamics.
- Green, A.E.S. (ed.) (1966). *The Middle Ultraviolet, its Science and Technology*, Wiley, New York.
- Green, A.E.S. (1989). Overview, Summary and Afterword. In: *Greenhouse Mitigation*, A. Green (ed.), Fuels and Combustion Technology Division, ASME, New York, vol. 7.
- Grobecker, A.J., S.C. Coroniti and R.H. Cannon, Jr. (1974). *The Effects of Stratospheric Pollution by Aircraft, Report of Findings Climatic Impact Assessment Program*.
- Krueger, A.J. et al. (1988). *Geophys. Res. Lett.*, **15**: 1356.
- MacDonald, J.E. (1971). *Assessment of Possible SST Effects on the Incidence of Skin Cancer, Technical Report*, Department of Atmospheric Physics, University of Arizona, (unpublished).
- Ramanathan et al. (1987). *Rev. of Geophys.*, **25**: 1441-1481.
- Rowland, F.S. and M.J. Molino (1975). Chlorofluoromethanes in the environment. *Rev. Geophys. Space Phys.*, **13**: 1-36.
- Stolarski, R.S. et al. (1986). *Nature*, **322**: 808.
- Stolarski, R.S. and R.J. Cicerone (1974). Stratospheric chlorine, a possible sink for ozone. *Can. J. Chem.*, **52**: 1610-1615.

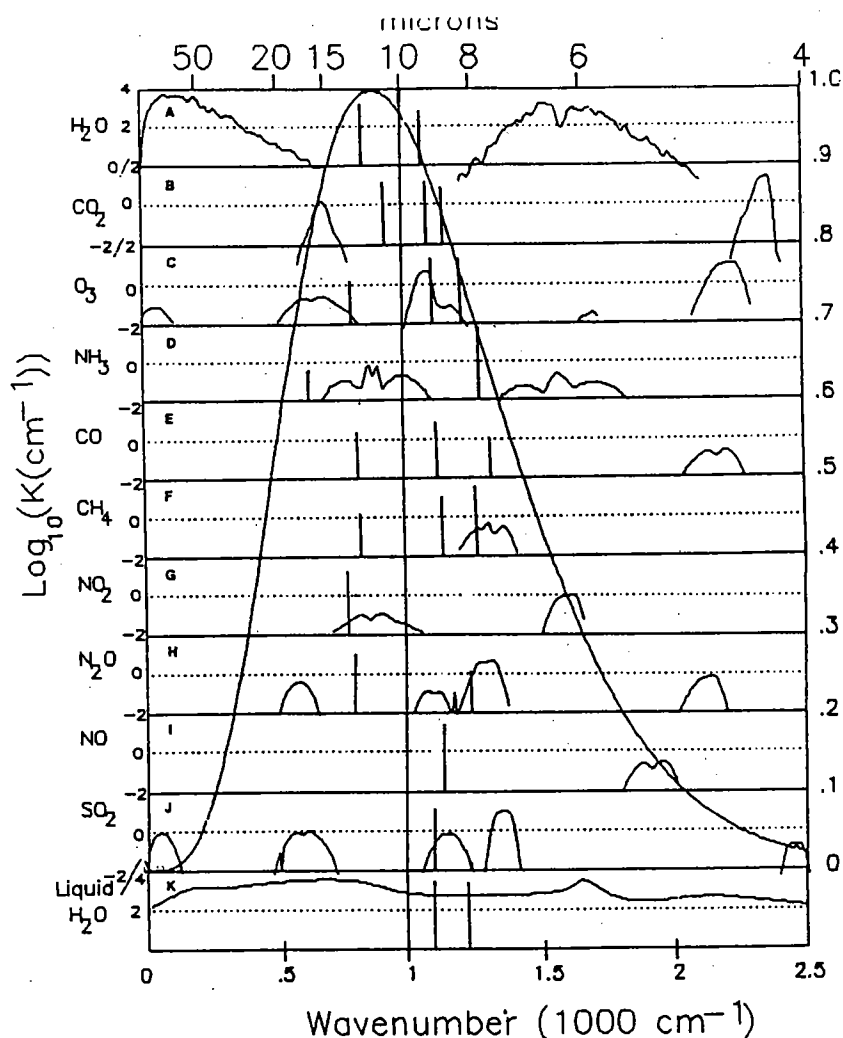

Figure 9.1.2: Greenhouse spectral region. The large curve in relation to the right scale represents the earth's relative longwave spectral radiance vs. wave number (lower scale) and wavelength (upper scale). The smaller curves for the trace gases in the ten strips give $\log_{10}k$ where k is a moderate resolution molecular band absorption coefficient. The lowest strip gives $\log_{10}k$ where k is the liquid water Lambert-Beer absorption coefficient. Both H_2O strips have vertical ranges of 0-4 whereas all others range from -2 to +2. The straight vertical lines in the strips labeled A, B ...etc. give the central locations of CFC's bands with heights represented by $\log_{10}I$ where I are the integrated band intensities all on vertical scales from 0-4. Here A- $CFCl_3$ (F11), B- CF_2Cl_2 (F12), C- CF_3Cl (C13), D- CF_4 (F14), E- $CHClF_2$ (F22), F- C_2F_6 (F116), G- CCl_4 , H- $CHCl_3$, J- CH_2F_2 and K- $CBrF_3$. Adapted from Green (1989).

Wubbles, D.J. (1989). On the mitigation of non-CO₂ Greenhouse gases. In: *Greenhouse Mitigation*, A. Green (ed.), Fuels and Combustion Technology Division, ASME, New York, vol. 7.

9.2 Laser Thermo-optical Methodologies for Environmental Analysis

J.F. Power
Department of Chemistry
Mc Gill University
Montreal, Quebec
H3A 2K6 Canada

Much general information concerning the structure and properties of refractory organic matter (ROM) has been correlated to the optical properties of these materials (Chen et al., 1977; Buffle et al., 1982). Solution phase studies of the absorption or emission properties of ROM have yielded correlation with molecular weight, or degree of aromaticity, for example (Chen et al., 1977; Underdown, 1982). Optical properties have also been used as a general monitor of the dissolved organic carbon content of samples collected from a common fresh-water source (Buffle et al., 1982). Steady state optical techniques have furthermore been demonstrated as useful probes for the investigation of metal ion binding to ROM, and for general estimates of particle size (Underdown, 1982).

The use of transient optical techniques such as flash photolysis and time resolved emission, on the other hand, have added a new dimension to studies of dissolved ROM (Fischer et al., 1985; Power et al., 1985; Frimmel et al., 1987). Recent flash photolysis studies of humic materials of terrestrial origin have identified several well defined transient species which are believed to be implicated in the solar induced photolysis of natural waters. These studies have led to a tentative identification of the photophysical states of the dissolved ROM which function as precursor to environmentally important species such as singlet molecular oxygen.

The use of conventional optical techniques, both steady state and transient have been well established but entail certain well defined disadvantages. In absorption work, especially flash photolysis, a significant preconcentration of the sample may be necessary in order to achieve adequate concentration levels for detection in the visible. In both absorption and emission work, the sample must be carefully filtered in order to remove particulates which produce a background of light scattering. Both of these disadvantages make conventional absorption and emission techniques unsuitable for *in-situ* studies on natural samples.

Some promising alternative absorption methodologies are provided by photoacoustic and photothermal spectrometric techniques, which measure optical absorption through the conversion of absorbed radiation to heat in the sample. The important advantages of the photoacoustic and photothermal detection methods are their ultrahigh sensitivity: it is readily possible to detect absorption coefficients below 10^{-4} cm^{-1} using these methods. Furthermore, the techniques are relatively insensitive in principle to light scattering by large non-absorbing particles. Both characteristics make thermo-optical techniques interesting as candidates for *in-situ* absorption measurements, since they eliminate several pretreatment steps.

In photoacoustic spectroscopy (Rosencwaig, 1980), heat dissipation in the sample is measured adiabatically by thermoacoustic wave generation. The thermoacoustic response of the liquid sample is detected by means of a piezoelectric transducer. However, the transducer response is very sensitive to geometry and requires a sophisticated theoretical

analysis to account for the form of the observed response. The photoacoustic technique also requires sophisticated wide bandwidth transient recording instrumentation for detection. Thermo-optical techniques such as laser thermal lensing (Dovich and Harris, 1980), involve sensitive detection of the thermal energy evolved in the sample through temperature dependent changes in the refractive index of the solvent. These changes are monitored optically through the detection of a lens-like element which forms due to the spatially inhomogeneous heating of the sample by a tightly focused laser beam. Recent work has shown that laser thermal lensing is capable of quantitating humic substances at levels below the freshwater level of 1-5 ppm (Power and Langford, 1988). The method also readily tolerates the presence of particulates. Both of these features make thermal lensing attractive for *in-situ* analysis.

Another powerful capability of the thermal lens effect methodology is for the study of transient photochemistry. Photochemical transients are detected via non-radiative pathways which release heat to the solvent medium. An interesting example is the detection of singlet oxygen, via pulsed thermal lensing. In past work (Fuke et al., 1983), singlet oxygen was generated in a solution through irradiation by a nanosecond pulse from a nitrogen laser ($\lambda = 337$ nm). The reaction enthalpies for photooxidation of a number of well known acceptor species were evaluated directly from the observed thermal lens transients. The detection of singlet oxygen is of obvious interest because of its participation in solar induced natural water photolysis. However, the thermo-optic detection mechanism is generally applicable to the detection of other transient species produced in the solar induced photolysis of natural waters.

Remote sensing is another area of implementation of thermal lens effect detection. The use of optical fibers as light pipes has already been reported for applications in thermal lens effect detection (Bailkowski, 1986; Nakanishi et al., 1987). Past designs reported in the literature have been far less sensitive than the conventional configuration. However, recent advances in instrumentation design have produced a new mode of detection utilizing a so-called near field measurement, in systems using the transient thermal lens effect (Power, 1990a, 1990b). The near field detection scheme has several advantages including vastly improved compactness of the optical train, greatly improved immunity to alignment or pointing noise in the laser systems, and enhanced sensitivity (one order of magnitude). The new design is readily adaptable to configuration as a remote sensor. Design equations are under development in this laboratory for an optimal fiber optic based thermal lens effect remote sensor which uses near field detection (Power, unpublished). A fully optimized system which uses inexpensive, commercially available apparatus is also under development.

Finally, while the sensitivity and relative simplicity of thermo-optic methods are attractive, a full understanding of the matrix effects to be encountered in natural samples is still to be worked out (Phillips et al., 1986; Terazima et al., 1989). Major difficulties may be encountered in marine samples where the salinity of the matrix may cause variations in the solvent's coefficient of refractive index (Phillips et al., 1986). Further improvements in analytical methodology will be required to compensate for these effects.

References

- Bailkowski, S.E. (1986). *Anal. Chem.*, **58**: 1706.

- Buffle, J., P. Deladoey, J. Zumstein and W. Heardi (1982). *Schweiz. Z. Hydrol.*, **44**: 327.
- Chen, Y., N. Senesi and M. Schnitzer (1977). *Soil. Sci. Amer. J.*, **41**: 32.
- Dovichi, N.J. and J.M. Harris (1980). *Anal. Chem.*, **52**: 695A.
- Fischer, A.M., D.S. Klinger, J.S. Winterle and T. Mill (1985). *Chemosphere*, **14**: 1299.
- Frimmel, F.H., H. Bauer, J. Putzien, P. Murasecco and A.M. Braun (1987). *Environ. Sci. Technol.*, **21**: 541.
- Fuke, K., N. Itoh and M. Ueda (1983). *J. Am. Chem. Soc.*, **105**: 1091.
- Nakanishi, K., T. Imasaka and N. Ishibashi (1987). *Anal. Chem.*, **59**: 1550.
- Phillips, C.M. S.R. Crouch and G.E. Leroi (1986). *Anal. Chem.*, **58**: 1710.
- Power, J.F. (1990a). *Pulsed Mode Thermal Lens Effect Detection in the Near Field via Thermally Induced Probe Beam Spatial Phase Modulation: A Theory*, (submitted).
- Power, J.F. (1990b). *Frequency Modulation Time Delay Thermal Lens Effect Spectrometry; A New Technique of Transient Photothermal Calorimetry*, (submitted).
- Power, J.F. and C.H. Langford (1988). *Anal. Chem.*, **60**: 842.
- Power, J.F., D.K. Sharma, C.H. Langford, R. Bonneau and J. Jousot-Dubien (1985). In: *Photochemistry of Environmental Aquatic Systems*, W.C. Cooper and R.G. Zika (eds.), A.C.S. Advances in Chemistry Series, Washington, D.C.
- Rosencwaig, A. (1980). *Photoacoustics and Photoacoustic Spectroscopy*, Chemical Analysis, vol. 57. Wiley,, New York.
- Terazima, N. Horiguchi and T. Azumi (1989). *Anal. Chem.*, **61**: 883.
- Underdown, A.W. (1982). Ph.D. thesis, Carleton University, Ottawa.

9.3 Photoproduction of Hydroxy Radicals at the Sea Surface and its Potential Impact on Marine Processes

Kenneth Mopper and Xianliang Zhou
University of Miami
Rosenstiel School of Marine and Atmospheric Science
Division of Marine and Atmospheric Chemistry
4600 Rickenbacker Causeway
Miami, Florida 33149-1098

The hydroxy radical ($\cdot\text{OH}$) is the most reactive, photochemically produced free radical in the environment (Mill, 1980; Zafriou, 1974; Zafriou et al., 1984). It plays a central role in atmospheric chemistry (Atkinson, 1985), but its role in aquatic environments is less clearly understood (Zafriou et al., 1984; Cooper et al., 1989). Flash photolysis studies (Zafriou, 1974) demonstrated that $\cdot\text{OH}$ is formed in seawater. Due to its high reactivity, $\cdot\text{OH}$ can directly, or indirectly, impact upon a number of marine processes, such as carbon cycling, photobleaching of dissolved organic matter (DOM), photoinhibition of phytoplankton growth, trace metal speciation, and reaction kinetics. A few estimates of $\cdot\text{OH}$ production rates and concentrations in surface seawater have been reported (Haag and Hoigné, 1985; Zepp et al., 1987), however there have been no actual measurements.

We evaluated photoproduction of $\cdot\text{OH}$ in seawater by two independent, established photochemical techniques. The first is based on H atom abstraction from an aliphatic alcohol, methanol, by $\cdot\text{OH}$. The formation rate of the main product, formaldehyde (Asmus et al., 1973; Walling and Kato, 1971), is then measured (Mopper and Stahovec, 1986):

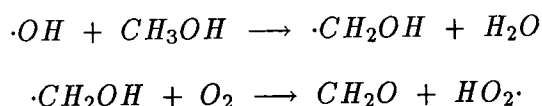

The other technique, which is more specific for $\cdot\text{OH}$, is based on addition of $\cdot\text{OH}$ to the aromatic (Ar) compound, benzoic acid. The formation rates of the addition products o, m, p-hydroxybenzoic acids (Mill, 1980; Asmus et al., 1973; Mill et al., 1980) are then measured:

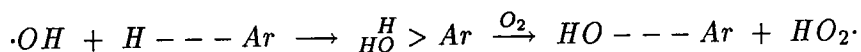

Similar, but less sensitive techniques, have been used to determine $\cdot\text{OH}$ production in freshwaters (Haag and Hoigné, 1985; Zepp et al., 1987; Mill et al., 1980). However, to our knowledge, these techniques have not been previously applied to seawater.

Samples were irradiated in quartz flasks with natural sunlight (4 h, solar noon, cloudless sky, 26°N). Time course experiments showed that production rates were linear during irradiations. The reproducibility of $\cdot\text{OH}$ production rates for coastal water was $< \pm 5\%$ for the methanol probe and about $\pm 10\%$ for the benzoic acid probe.

Using both scavengers, sunlight-induced $\cdot\text{OH}$ production rates were measured for different coastal seawater samples with and without an added $\cdot\text{OH}$ source (H_2O_2 , added at 200–500 times natural levels (Haag and Hoigné, 1985; Mill et al., 1980), and also in irradiated deionized water with added H_2O_2 . Production rates obtained using these two

scavengers agreed within $\pm 20\%$ for all runs. The excellent agreement indicates that, even though the methanol probe may be less specific for $\cdot\text{OH}$ than benzoic acid, under our experimental conditions it appears to accurately measure $\cdot\text{OH}$ production rates in seawater. Because of its much higher sensitivity, we used the methanol probe to measure $\cdot\text{OH}$ production rates in open ocean samples where we anticipated much lower rates than coastal samples.

Steady-state concentrations and production rates of $\cdot\text{OH}$ in different seawaters are given in Table 9.3.1. Concentrations of $\cdot\text{OH}$ in surface seawaters are 1–2 orders of magnitude lower than those reported for organic- and nitrate-rich freshwaters (Haag and Hoigné, 1985; Zepp et al., 1987; Mill et al., 1980). The steady-state concentration of $\cdot\text{OH}$ is much higher in upwelling and coastal waters than in open oceanic surface water. From past studies (Zafriou, 1974, 1983; Haag and Hoigné, 1985; Zepp et al., 1987; Mill et al., 1980), the main sources of $\cdot\text{OH}$ in seawater should be photolysis of nitrate, nitrite, hydrogen peroxide and DOM, and Fenton-type reactions. We performed experiments to evaluate the relative importance of these sources. These results are included in Table 9.3.1. Our measured $\cdot\text{OH}$ production rate from nitrate photolysis was $3.0 \times 10^{-13} \text{ M/s}/\mu\text{M} \cdot \text{NO}_3^-$, which is in excellent agreement with Zepp et al. (1987) for freshwater. The $\cdot\text{OH}$ production rates from nitrite and hydrogen peroxide photolysis were $2.3 \times 10^{-11} \text{ M/s}/\mu\text{M} \cdot \text{NO}_2^-$ and $4.1 \times 10^{-12} \text{ M/s}/\mu\text{M} \cdot \text{H}_2\text{O}_2$, respectively. Because of the low steady-state concentrations of hydrogen peroxide (Zika et al., 1985) and dissolved iron and copper (Moffet and Zika, 1987), photolysis of hydrogen peroxide and Fenton-type reactions are insignificant sources of $\cdot\text{OH}$ in seawater. Also, when we added EDTA (to chelate trace metals) or catalase (to destroy H_2O_2) to coastal and open ocean seawater, no change in $\cdot\text{OH}$ production rates was observed. Table 9.3.1 shows that nitrate and nitrite photolysis will be important $\cdot\text{OH}$ sources in some upwelling areas, and at times in productive coastal waters. However, over most of the ocean's surface, the only remaining major source for $\cdot\text{OH}$ is DOM (accounting for $> 95\%$ of the total production). Even when nitrate-rich deep water from the Sargasso Sea was brought up to the surface and irradiated on deck (Figure 9.3.1) only about 15–20% of the $\cdot\text{OH}$ production was due to nitrate photolysis.

DOM has been previously shown to be a photochemical source for $\cdot\text{OH}$ in studies with freshwater (Mill, 1980; Haag and Hoigné, 1985; Mill et al., 1980; Kotzias et al., 1987). As evidence for the role of DOM as an $\cdot\text{OH}$ source of seawater, we found strong correlations between DOM absorbance (at 300 nm) or fluorescence (350 nm excitation, 450 nm emission (Zafriou et al., 1984) with $\cdot\text{OH}$ production in a large number of seawater samples (Figure 9.3.1 ($f^2 > 0.93$)). Also, as shown in Table 9.3.1, addition of humic-rich freshwater to humic-poor seawater significantly enhanced $\cdot\text{OH}$ photoproduction rates. The enhancement was in direct proportion to the DOM absorbance and to the fraction of humic-rich water present. Furthermore, solar-corrected quantum yields for photoproduction of $\cdot\text{OH}$ in coastal seawater (Kieber and Mopper, submitted) and for seawater containing purified humic substances (K. Mopper and R.J. Kieber, unpublished results) showed that the photoactive wavelengths in the solar spectrum responsible for this production are restricted to a narrow band in the UV-B1 region of 290–315 nm, which corresponds to a $1/e$ light penetration depth of about 8 m in the open ocean (Smith and Baker, 1979). Nearly identical spectra were obtained for photobleaching (loss of DOM absorbance) in seawater (Kieber and Mop-

Table 9.3.1: Measured and Estimated OH Steady-State Concentrations and Fluxes in Sunlight Irradiated Seawater and Freshwater.

Sample ^a	$\frac{[\text{OH}]_{\text{ss}}}{\times 10^{-18} \text{ M}}$	Total Flux $\times 10^{-12} \text{ M/s}$ (nM/h)	% of Total Flux from Different Sources (Concentration of Sources, μM) ^b			
			NO_3^-	NO_2^-	H_2O_2	Other (DOC)
Open Ocean Surface Water (Sargasso Sea, n = 6)	1.1 ± 0.1	2.8 ± 0.2 (10.1 nM/h)	<1% (<0.05 μM)	- (UD) ^c	<4% (<0.05 μM)	>95% (200 μM)
Gulf Stream Surface Water (n = 1)	1.2	3.1 (11.2 nM/h)		N.D. ^d		
Deep Oceanic Water (Sargasso Sea, >700 m, n = 7)	6.3 ± 0.3	15.9 ± 0.7 (57.2 nM/h)	19% (10 μM)	1% (0.01 μM)	3% (0.1 μM)	77% (70 μM)
Deep Gulf Stream Water (700 m, n = 1)	5.8	14.7 (52.9 nM/h)		N.D. ^d		
Subtropical Coastal Water (Biscayne Bay, FL, high tide, n = 4)	9.7 ± 1.2	24.4 ± 3.0 (87.8 nM/h)	2% (2.0 μM)	- (UD) ^c	2% (0.2 μM)	96% (300 μM)
Subtropical Coastal Water (Biscayne Bay, FL, low tide, n = 5)	13.7 ± 1.7	34.5 ± 4.3 (124.2 nM/h)		N.D. ^d		
Temperate Coastal Water (Vineyard Sound, MA, n = 1)	10.6	26.5 (95.4 nM/h)		N.D. ^d		
Equatorial Upwelled Water (estimated)	7.4	18.6 (67.0 nM/h)	3% (5 μM)	25% (0.2 μM)	3% (0.1 μM)	65% (200 μM)
Coastal Upwelled Water (estimated)	26.3	66.1 (238 nM/h)	7% (15 μM)	35% (1 μM)	6% (0.1 μM)	52% (300 μM)
10% Everglades Water in Biscayne Bay Water (n = 1)	30.1	68.9 (248 nM/h)		N.D. ^d		
DOM-rich freshwater (Everglades n = 2)	840 ^e	420 ± 58 (1.5 × 10 ³ nM/h)		N.D. ^d		

^an = number of samples used for the experiment.^bConcentrations of H_2O_2 and DOC were estimated from published values (Sugimura and Suzuki, 1988; Mopper et al., in press).^cUD = Undetectable.^dN.D. = Not Determined.^eThis steady-state concentration was calculated with a measured scavenging coefficient of $5 \times 10^3 \text{ s}^{-1}$ (Zafriou et al., 1987).

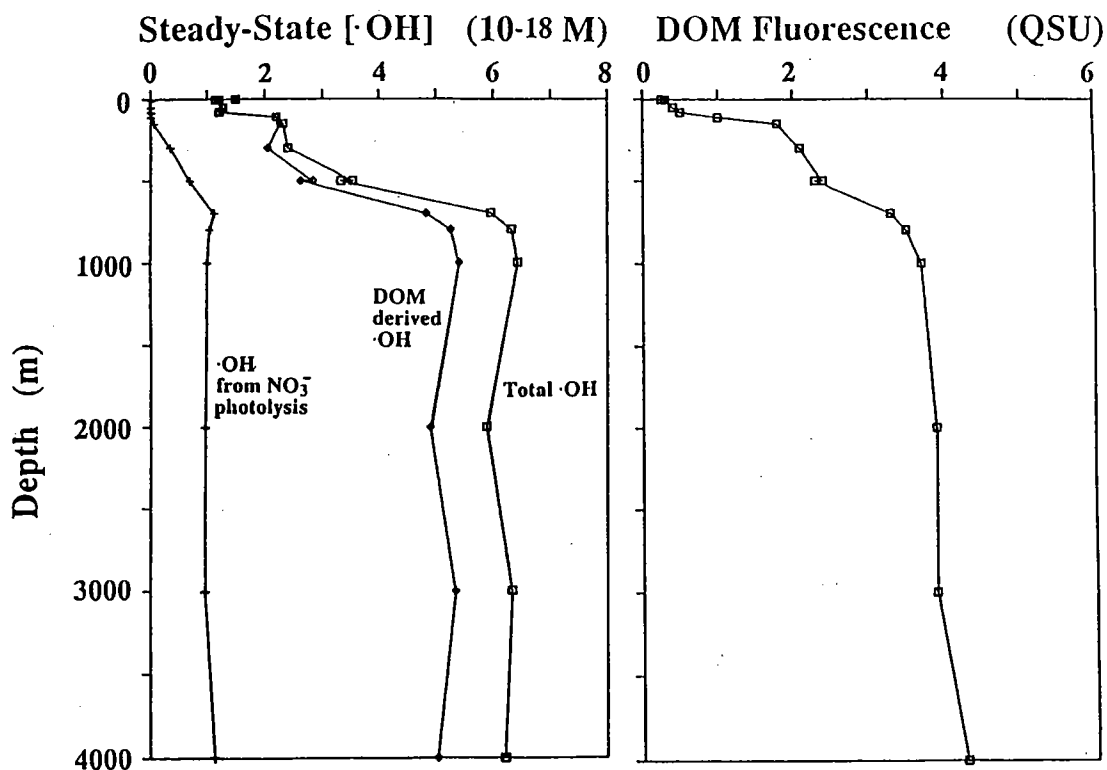

Figure 9.3.1: Left: Steady-state $\cdot\text{OH}$ concentrations in sunlight irradiated Sargasso Sea water plotted against sampling depth. Samples were brought to the surface and irradiated on deck in quartz flasks, using natural sunlight. At this station ($26^{\circ}00'\text{N}$, $76^{\circ}00'\text{W}$), the mixed layer extends down to about 80 m; the chlorophyll a maximum occurs at 100–140 m; and the oxygen minimum occurs at about 800–900 m. Right: Profile of DOM fluorescence (excitation 360 nm, emission 450 nm) at the same station. The fluorescence was normalized to a quinine sulfate standard (1 QSU = 1 ppb in 0.1 N H_2SO_4).

per, submitted). These results suggest that the relationship between DOM absorbance and photoproduction of $\cdot\text{OH}$ from DOM is not simply incidental.

From competition kinetics experiments (Zhou and Mopper, submitted), we estimate that scavenging by Br^- will consume about 93% of $\cdot\text{OH}$ photoproduction, which is in agreement with past estimates of 89–98% (Zafriou, 1974; Zafriou et al., 1987). Thus, approximately 7% of the $\cdot\text{OH}$ will react directly with other components of seawater. In addition, reactive daughter products of $\cdot\text{OH}$, such as bromine-containing radicals, will also attack these components (Zafriou, 1974; Zafriou et al., 1987). The extent of attack on dissolved organic carbon (DOC) will depend on the apparent rate constant, k'_{DOC} , for the reaction of $\cdot\text{OH}$ with DOC. This constant is expected to vary with DOC source and history of the water. Therefore, experiments were performed to measure k'_{DOC} in different seawaters (Zhou and Mopper, submitted). In these experiments, an $\cdot\text{OH}$ source, H_2O_2 (20–150 μM) was added to coastal and open ocean samples and photoproduction of identifiable low molecular weight (LMW) products, formaldehyde, acetaldehyde, glyoxal, and keto acids, was monitored:

$$d[\text{DOC}]/dt = -k_{\text{DOC}}[\text{DOC}][\cdot\text{OH}] = -k'_{\text{DOC}}[\cdot\text{OH}] = \text{production rate of products}$$

Since steady-state concentrations of $\cdot\text{OH}$ were constant in all samples, differences in photoproduction of LMW products were due only to differences in DOC reactivities towards $\cdot\text{OH}$ (and its daughter products). Values of k'_{DOC} found were: $5\text{--}8 \times 10^4 \text{ s}^{-1}$ for subtropical and temperate coastal surface waters, $1\text{--}2 \times 10^4 \text{ s}^{-1}$ for open ocean surface water, and $4\text{--}5 \times 10^4 \text{ s}^{-1}$ for open ocean deep water (> 1000 m depth). These rate constants are conservative since they are based on the production of only identifiable LMW products.

Using these apparent rate constants and a deep water DOC concentration of about one third of open ocean surface DOC (Sugimura and Suzuki, 1988), we calculate that deep water DOC is about 8–10 times more easily degraded by $\cdot\text{OH}$ attack than surface water DOC. The relatively low reactivity of DOC in surface seawater toward $\cdot\text{OH}$ is probably due to extensive photobleaching. This low reactivity might in part explain why conventional DOC analyzers relying on photochemical or persulfate oxidation appear to miss a substantial fraction of surface DOC, but are in better agreement with high temperature combustion methods for deep sea DOC (Sugimura and Suzuki, 1988; Toggweiler, 1988).

Reaction of $\cdot\text{OH}$ with DOC should speed up the degradation of biologically refractory organic matter at the sea surface, since LMW products from this reaction can be readily taken up and oxidized by organisms (Kieber et al., 1989; Geller, 1986). This has interesting implications regarding the geochemical cycling of organic carbon in the sea (Mopper et al., in press). Using our estimates of k'_{DOC} , published spatial distributions of open ocean, coastal and upwelling regimes (Ryther, 1969), and typical DOC concentrations in these different regimes (Sugimura and Suzuki, 1988), we calculate that the residence time for oceanic DOC is roughly $4 \times 10^4 \text{ y}$. Although this value is about 6–7 times greater than the measured ^{14}C age of deep sea DOC (Williams and Druffel, 1987), it is still significant because our k'_{DOC} values are conservative and our estimate is based only on attack of DOC by $\cdot\text{OH}$ (and its daughter products); i.e., other degradation pathways, such as direct photolysis, are not considered.

The photochemical flux of $\cdot\text{OH}$ (and its reactive daughter products) at the sea surface may also impact upon biota residing there, especially in upwelling waters and in regions

with high or increasing UV-B light flux. High fluxes of reactive free radicals can destroy key biomolecules in organisms (Halliwell et al., 1987), thereby retarding growth and enhancing mutation (Halliwell and Gutteridge, 1985). Since we measure $\cdot\text{OH}$ fluxes up to several hundred nM/h (Table 9.3.1) it seems feasible that photoinhibition at the sea surface, especially in productive coastal and upwelling waters (Smith and Baker, 1980), is in part due to $\cdot\text{OH}$ and its reactive daughter products.

References

- Asmus, K.-D., H. Mockel and A. Henglein (1973). *J. Phys. Chem.*, **77**: 1218-1221.
- Atkinson, R. (1985). *Chem. Rev.*, **85**: 69-201.
- Cooper, W.J., R.G. Zika, R.G. Petasne and A.M. Fischer (1989). In: *Aquatic Humic Substances: Influence on Fate and Treatment of Pollutants*, I.H. Suffet and P. MacCarthy (eds.), American Chemical Society, Washington, D.C., pp. 333-362.
- Geller, A. (1986). *Limnol. Oceanogr.*, **31**: 755-764.
- Haag, W.R. and J. Hoigné (1985). *Chemosphere*, **14**: 1659-1671.
- Halliwell, B. and J.M.C. Gutteridge (1985). In: *Free Radicals in Biology and Medicine*, Oxford University Press Clarendon, London/New York.
- Halliwell, B., J.M.C. Gutteridge and O.I. Aruoma (1987). *Analytical Biochem.*, **165**: 215-219.
- Kieber, D.J., J. McDaniel and K. Mopper (1989). *Nature (London)*, **341**: 637-639.
- Kotzias, D., M. Herrmann, A. Zsolnay, R. Beyerle-Pfnur, H. Parlar and F. Korte (1987). *Chemosphere*, **16**: 1463-1468.
- Mill, T. (1980). In: *The Handbook of Environmental Chemistry*, O. Hutzinger (ed.), Springer-Verlag, Berlin, Vol. 2/Part A, pp. 77-105.
- Mill, T., D.G. Hendry and H. Richardson (1980). *Science*, **207**: 886-887.
- Moffett, J.W. and R.G. Zika (1987). *Environ. Sci. Technol.*, **21**: 804-810.
- Mopper, K. and W.L. Stahovec (1986). *Mar. Chem.*, **19**: 305-321.
- Mopper, K., R.G. Zika and A.M. Fischer (in press). In: *Humic Substances: IV*, P. MacCarthy, E.T. Gjessing, R.F.C. Mantoura and P. Sequi (eds.).
- Ryther, J.H. (1969). *Science*, **166**: 72-76.
- Smith, R.C. and K.S. Baker (1979). *Photochem. Photobiol.*, **29**: 311-323.
- Smith, R.C. and K.S. Baker (1980). *Science*, **208**: 592-593.
- Sugimura, Y. and Y. Suzuki (1988). *Mar. Chem.*, **241**: 105-131.

- Toggweiler, J.R. (1988). *Nature*, **334**: 468.
- Walling, C. and S. Kato (1971). *J. Amer. Chem. Soc.*, **93**: 4275-4281.
- Williams, P.M. and E.R.M. Druffel (1987). *Nature*, **330**: 246-248.
- Zafriou, O.C. (1974). *J. Geophys. Res.*, **79**: 4491-4497.
- Zafriou, O.C. (1983). In: *Chemical Oceanography*, J.P. Riley and R. Chester (eds.), Academic Press, London, Vol. 8/2nd Ed., pp. 339-379.
- Zafriou, O.C., J. Joussot-Dubien, R.G. Zepp and R.G. Zika (1984). *Environ. Sci. Technol.*, **18**: 358-371.
- Zafriou, O.C., M.B. True and E. Hayon (1987). In: *Photochemistry of Environmental Aquatic Systems*, R.G. Zika and W.J. Cooper (eds.), American Chemical Society, Washington, D.C., pp. 89-105.
- Zepp, R.G., J. Hoigné and H. Bader (1987). *Environ. Sci. Technol.*, **21**: 443-450.
- Zika, R.G., J. Moffett, W.J. Cooper, R. Petasne and E. Saltzman (1985). *Geochim. Cosmochim. Acta*, **49**: 1173-1184.

10 Posters

10.1 Primary Productivity in the Southeast Pacific Ocean: Effect of Enhanced Ultraviolet-B Radiation

Michael Behrenfeld¹, John Hardy¹, Hermann Gucinski² and Andrew Wones²

¹Department of General Science
Oregon State University
Corvallis, Oregon 97331-6505

²NSI Technology Services Inc. and
U.S. Environmental Protection Agency
Environmental Research Laboratory
Corvallis, Oregon 97333

Anthropogenic releases of trace gases into the atmosphere are causing a decrease in stratospheric ozone concentrations and a subsequent increase in solar ultraviolet-B (UV-B) (280–320 nm) radiation reaching the earth's surface. The objective of this study was to determine the acute effects of enhanced UV-B radiation on the primary production of natural marine phytoplankton assemblages sampled over a wide latitudinal gradient and incubated under ambient levels of photosynthetically active radiation (PAR). Samples were collected approximately every 2° to 4° latitude in the southeast Pacific. Primary production was measured using the carbon-14 light and dark bottle technique. Fluorescent sunlamps were used to enhance the dose of UV-B radiation above ambient. Samples were maintained at ambient surface water temperature in a flow-through incubation tank. Enhanced UV-B radiation caused a significant mean decrease of 34% in surface water primary production. Decreases in primary production increased with increasing doses of UV-B radiation and with increasing assimilation efficiencies. Results indicate that predicted increases in ambient solar UV-B radiation resulting from stratospheric ozone depletion could result in mean annual decreases of near-surface oceanic primary production of 1% near the equator to 31% at high southern latitudes.

10.2 Mechanistic Investigations of the Novel, *Non Heme* Vanadium Bromoperoxidases: Evidence for Singlet Oxygen Formation

Alison Butler, R.R. Everett and J.R. Kanofsky
 Department of Chemistry
 University of California, Santa Barbara
 Santa Barbara, California 93106

Vanadium-bromoperoxidase (V-BrPO) is a newly discovered enzyme, found primarily in marine organisms. It has been isolated from a variety of marine algae (e.g. *Ascophyllum nodosum* (Vilter, 1984; Wever et al., 1985; Everett and Butler, 1989), *Laminaria saccharina* (de Boer et al., 1986), *Ceramium rubrum* (Krenn et al., 1987), etc.) and a terrestrial lichen (Plat et al., 1987). V-BrPO is a member of a new class of *non heme*-containing haloperoxidases distinct from the well known FeHeme haloperoxidases (e.g., chloroperoxidase, bromoperoxidase and iodoperoxidase). FeHeme bromoperoxidases have also been discovered in marine organisms, including the alga *Penicillus capitatus* (Manthey and Hager, 1981). In addition to the widespread occurrence of bromoperoxidases in marine organisms, the existence of brominated compounds is nearly ubiquitous in marine organisms. Of interest to the topic of this workshop is the production of bromoform and dibromomethane by certain temperate marine algae, which has been linked to destruction of the Arctic ozone layer (Gschwend et al., 1985; Wever, 1988).

Bromoperoxidases catalyze the oxidation of bromide by hydrogen peroxide which results in the bromination of suitable organic substrates. A variety of organic compounds are brominated, including β -diketones, β -ketoacids, phenols, nitrogen- and sulfur-heterocycles, etc. Monochlorodimedone (2-chloro-5,5-dimethyl-1,3-dimedone, MCD), a cyclic β -diketone, is the classic substrate used to determine the specific activity of haloperoxidases. In the absence of a suitable organic substrate for halogenation, the oxidized bromine intermediate reacts with a second equivalent of hydrogen peroxide producing dioxygen and bromide, in a "bromide-assisted" reaction of hydrogen peroxide disproportionation (Everett and Butler, 1989; Manthey and Hager, 1981). Recently, we have reported that the rate of dioxygen formation catalyzed by V-BrPO at pH 6.5, is equal to the rate of bromination of monochlorodimedone (MCD) which suggests that both the MCD bromination reaction and the bromide-assisted disproportionation of hydrogen peroxide reaction proceed through the formation of a common, rate limiting intermediate (Scheme 1) (Everett and Butler, 1989). The exact identity of the intermediate (i.e., hypobromous acid/tribromide or an enzyme-bound bromonium ion type intermediate) has not been established, unambiguously. In sharp contrast to the FeHeme haloperoxidases, V-BrPO does not catalyze the direct disproportionation of hydrogen peroxide (i.e., catalatic activity) (Everett and Butler, 1989).

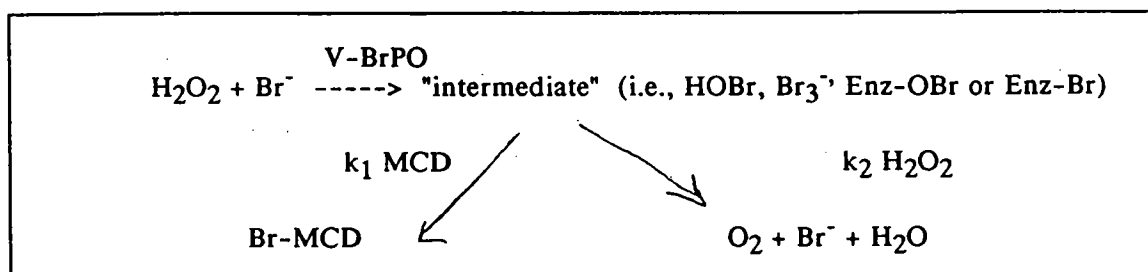

Scheme 1

The halide assisted pathway for hydrogen peroxide disproportionation catalyzed by several FeHeme haloperoxidases (e.g., chloroperoxidase, lactoperoxidase, myeloperoxidase, eosinophil peroxidase) produces singlet dioxygen ($^1\text{O}_2$), as identified by the characteristic emission at 1268 nm resulting from the decay of $^1\text{O}_2(^1\Delta_g)$ to $^3\text{O}_2(^3\Sigma_g^-)$ (Kanofsky, 1989a and 1989b). The V-BrPO system (i.e., Br^- , H_2O_2 , V-BrPO) also generates near infrared emission, characteristic of singlet oxygen. The emission has a peak intensity near 1268 nm, is greatly increased in $^2\text{H}_2\text{O}$ -containing buffers and is greatly decreased by the singlet oxygen quenchers, histidine and azide (Butler et al., submitted). The yield of singlet oxygen is ca. 80% of the theoretical yield. A unique feature of V-BrPO distinct, from the the Fe-Heme haloperoxidases, is the remarkable stability of the *non heme* enzymes in the presence of singlet oxygen and oxidized bromine species. V-BrPO turns over multiple aliquots of 2 mM hydrogen peroxide without losing efficiency. In contrast FeHeme-lactoperoxidase is completely inactivated after turnover of the first aliquot of 2 mM hydrogen peroxide and FeHeme-chloroperoxidase is 50% deactivated. The profile of singlet oxygen formation by V-BrPO and the near stoichiometric yield of singlet oxygen suggest that the mechanism of singlet oxygen formation is the same as the mechanism of dioxygen formation determined by oxygen-probe measurements (Butler et al., submitted).

The biological role of singlet oxygen production is a controversial issue. Singlet oxygen in biological systems is generally viewed as a destructive agent. V-BrPO is not destroyed by large quantities of singlet oxygen, contrary to the FeHeme haloperoxidases. In addition, the biosyntheses of several types of marine natural products can be mediated by singlet oxygen (e.g., bi-indole compounds).

Quantitative production of singlet oxygen was measured by the chemiluminescence at 1268 nm. The emission spectrometer, employing a near-infrared (1000–1700 nm), liquid-nitrogen cooled germanium diode detector has been described previously (Kanofsky, 1989b). The emission intensity produced by the enzyme-catalyzed reactions was calibrated relative to the emission from singlet dioxygen produced by reaction of hydrogen peroxide and hypochlorous acid at identical pH (Held et al., 1978), as previously discussed (Kanofsky, 1989a).

References

- de Boer, E., M.G.M. Tromp, H. Plat, G.R. Krenn and R. Wever (1986). *Biochim. Biophys. Acta*, **872**: 104–115.
- Everett, R.R. and A. Butler (1989). *Inorg. Chem.*, **28**: 393–395.
- Gschwend, P.M., J.K. MacFarlane and K.A. Newman (1985). *Science*, **227**: 1034–1036.
- Held, A.M., D.J. Halko and J.K. Hurst (1978). *J. Am. Chem. Soc.*, **100**: 5732–5740.
- Kanofsky, J.R. (1989a). *Chem.-Biol. Interactions*, **70**: 1–28.
- Kanofsky, J.R. (1989b). In: *Oxygen Radicals in Biology and Medicine*, M.G. Simic, K.A. Taylor, J.F. Ward and C. von Sonntag (eds.), Plenum Publishing Corp., New York, pp. 211–218.
- Krenn, B.E., H. Plat and R. Wever (1987). *Biochim. Biophys. Acta*, **912**: 287–291.

- Manthey, J.A. and L.P. Hager (1981). *J. Biol. Chem.*, **256**: 11232-11238.
- Plat, H., B.E. Krenn and R. Wever (1987). *Biochem. J.*, **248**: 277-279.
- Vilter, H. (1984). *Phytochem.*, **23**: 1387-1390.
- Wever, R. (1988). *Nature*, **335**: 501 (letter).
- Wever, R., H. Plat and E. de Boer (1985). *Biochim. Biophys. Acta*, **830**: 181-186.

10.3 Pure Singlet Oxygen Toxicity in Mammalian Cells

Thomas A. Dahl¹, W. Rogert Midden², James E. Klaunig³ and Randall Ruch³

¹Department of Pharmacology
Tufts University
Boston, Massachusetts 02111

²Center for Photochemical Sciences
Bowling Green State University
Bowling Green, Ohio 43403

³Department of Pathology
Medical College of Ohio
Toledo, Ohio 43699

Singlet oxygen ($^1\text{O}_2$) is the lowest energy electronically excited state ($^1\Delta_g$) of molecular oxygen. Photosensitization, the conversion of light energy to chemical reactivity, can be an extremely efficient means of generating $^1\text{O}_2$ relevant to living systems. $^1\text{O}_2$ is more reactive than the ground state oxygen molecule with a wide variety of biologically and chemically important substrates. These substrates include cellular components such as proteins, unsaturated fatty acids and nucleic acids. In order to study the cellular effects of $^1\text{O}_2$, a system was developed for the exposure of bacteria to $^1\text{O}_2$ in the absence of non- $^1\text{O}_2$ reactants (Dahl et al., 1987). Using this clean $^1\text{O}_2$ source, the potent cytotoxicity, without genotoxicity or mutagenicity, of $^1\text{O}_2$ in bacteria was demonstrated (Dahl et al., 1987, 1988). Dose comparisons demonstrated that $^1\text{O}_2$ is 10,000 times more toxic than equimolar H_2O_2 . In order to explore the cellular and chemical mechanisms of $^1\text{O}_2$ toxicity in mammalian cells, the bacterial-pure $^1\text{O}_2$ exposure system was modified to allow the exposure of mammalian cells to pure exogenous $^1\text{O}_2$. The modifications included carrying out exposures in a humidified chamber, and keeping the membrane filters wicked from beneath with growth medium-saturated filter paper. Survival was determined in murine primary hepatocytes by measuring leakage of LDH activity from cells following $^1\text{O}_2$ exposure. Cell viability by this criterion was reduced an order of magnitude with only 40% as much singlet oxygen as was required for the same killing response in gram-negative bacteria. While not indicative of the vital cellular target(s) or chemical reaction(s) involved, this preliminary result demonstrates unambiguously the potent cytotoxicity of $^1\text{O}_2$ in mammalian cells.

References

- Dahl, T.A., W.R. Midden and P.E. Hartman (1987). *Photochem. Photobiol.*, **46**: 345-352.
Dahl, T.A., W.R. Midden and P.E. Hartman (1988). *Mutation Research*, **201**: 127-136.

10.4 Effect of UV-B Irradiance on ^{15}N -Nitrate Utilization by Synchronized *Synedra planctonica*

G. Döhler and I. Biermann
Botanisches Institut der Universität
Siesmayerstraße 70
D-6000 Frankfurt am Main
Federal Republic of Germany

Recently, the impact of UV-B radiation (290–320 nm) on metabolic processes of phytoplankton species was investigated in more detail using pure cultures as well as natural phytoplankton populations under laboratory and field conditions. Uptake and assimilation of inorganic nitrogen was found to be more sensitive to UV-B exposure than the carbon metabolism of the microalgae and a species-dependent response has been detected, too. Synchronized cultures of *Synedra planctonica* were used to obtain information on a possible stage-dependent behavior to UV-B radiation. Algae have been irradiated with UV-B (2 h, 400 J m^{-2} weighted after Caldwell, 1971) during the 3 division cycle at different times. After UV-B radiation during DNA-synthesis in the dark (8–10 h), ^{15}N -nitrate uptake was markedly depressed during the following light period. Only a slight UV-effect was found after the synthesis of proteins and other metabolites have ceased (20–22 h). Similar results were obtained by studies of ^{15}N -incorporation into the protein fractions. The fluence of UV-B on the activities of nitrate reductase, glutamine synthetase and glutamate synthase and a possible reactivation was measured with *Synedra* cells harvested during the light period. UV-B exposure at the beginning and the end of the light period resulted in a total inhibition of the nitrate reductase activity whereas a reduction of 34% could be observed between both exposure times. In dependence on the time of UV-B radiation, the activity of glutamate synthase was differently reduced. However, an increase in glutamine synthetase activity could be measured at the end of the light period. Results were discussed with reference to the target of UV-B and the stage-dependent response to UV-B radiation.

10.5 A Biological Dosimeter to Evaluate the Transmission of Ultraviolet Radiation in Aquatic Environments

Deneb Karentz and Louise H. Lutz
Laboratory of Radiobiology and Environmental Health
University of California
San Francisco, California 94143-0750

A biological dosimeter, based on the sensitivity of a DNA repair-deficient strain of *Escherichia coli* (CSR06) to ultraviolet (UV) radiation, has been developed for use in aquatic environments. This method permits evaluation of the relative penetration of biologically active UV radiation within a water column. The dosimeter was used in coastal Antarctic waters to determine the vertical profile of biologically active UV light to a depth of 30 m. Biological effects of UV-B (280–320 nm) radiation were consistently detected to 10 m and on occasion to 20 and 30 m. With the use of selective filters, the biological dosimeter can discriminate between the effects of UV-A (320–400 nm) and UV-B. The method permits simultaneous measurements at a number of depths and reflects the actual biological effect of exposure to sunlight over a selected time interval. It is relatively inexpensive and easy to use. Biological dosimeters may provide a means of standardizing in-water UV measurements in all types of aquatic habitats and at any geographical location.

10.6 Fluorescence Detection of Carbon-Centered Radicals in Aqueous Solution

David J. Kieber and Neil V. Blough
Chemistry Department
Woods Hole Oceanographic Institution
Woods Hole, Massachusetts 02543

A simple, highly sensitive method for the simultaneous determination of arrays of carbon-centered radicals in aqueous systems is described. Radicals are efficiently trapped by an amino-nitroxide to form stable products which are then reacted with fluorescamine to produce highly fluorescent adducts. The adducts are easily separated by reversed-phase high performance liquid chromatography. The detection limit for individual radical adducts (0.5 to 2 nm) is two to three orders of magnitude lower than those of current methods employing electron paramagnetic resonance detection. Results on the photolysis of ketones and α -keto acids demonstrate the potential of this technique. The first evidence for the photolytic production of carbon-centered radicals in natural waters is presented. This approach should be widely applicable to the study of radical processes in biological and chemical systems.

10.7 Photochemical Source of Biological Substrates in Seawater: Implications for Carbon Cycling

David J. Kieber¹, Julie McDaniel² and Kenneth Mopper³

¹Chemistry Department
Woods Hole Oceanographic Institution
Woods Hole, Massachusetts 02543

²Marine Institute
University of Georgia
Sapelo Island, Georgia 31327

³Rosenstiel School of Marine and Atmospheric Science
University of Miami
Miami, Florida 33149

Dissolved organic carbon (DOC) in seawater represents one of the largest reservoirs of carbon on the earth. The major fraction of this DOC is generally believed to be composed of old, biologically refractory material such as humic substances for which the removal mechanisms remain largely unknown. One potentially important removal process in the ocean that has not been investigated is the photochemical breakdown of this DOC in the photic zone to form biologically labile organic products. Here we show that the biological uptake of pyruvate is highly correlated to its rate of photochemical production in seawater; and that the photochemical precursor(s) of this α -keto acid is from the fraction of DOC larger than a nominal molecular weight of 500. This is the first evidence that photochemical oxidation of high molecular weight marine DOC, which is presumably biologically refractory, results in the production of a compound utilized by plankton as a substrate. Results of this study have important implications regarding our present views of the oceanic carbon cycle, particularly with respect to planktonic food web dynamics and the global carbon budget.

10.8 Variations of Peroxide in the Sargasso Sea

William L. Miller and Dana R. Kester
Graduate School of Oceanography
University of Rhode Island
Narragansett, Rhode Island 02882

A full description of the redox characteristics of trace elements in the photic zone requires baseline information on the concentration and short term variations of redox active compounds. Hydrogen peroxide has been shown to play a significant role in certain metal redox reactions (Moffett and Zika, 1987) which may in turn influence biological productivity (Martin and Fitzwater, 1988; Martin and Gordon, 1988). Peroxide is formed by secondary photochemical reactions and its stability relative to other light generated transients makes it a useful indicator of overall photochemical processes in the marine environment. Since variations of peroxide concentrations result from a kinetic balance of formative, destructive, and input processes, changes in the levels of UV light responsible for photochemical formation could change peroxide kinetics and alter observed levels.

Peroxide was measured aboard the R/V ENDEAVOR during May in the vicinity of the BIOWATT mooring (34°N, 70°W) in the western Sargasso Sea. Discrete surface samples were analyzed throughout the day and night for 10 consecutive days using fluorescent measurement of the enzyme catalyzed dimerization of (p-hydroxyphenyl)acetic acid (POHPAA) by peroxide (Miller and Kester, 1988). A base peroxide concentration above 100 nM was observed with daily variations of about 40 nM. A notable exception to this pattern resulted from an evening rain shower which produced elevated surface water peroxide concentrations throughout the night. *In situ* apparent rates show accumulation to occur in the Sargasso Sea at about 4 nM/hr and disappearance of peroxide in surface water after dark to proceed at about 5 nM/hr. Vertical profiles show correlation to temperature profiles and suggest a significant role of mixing in the mixed layer distribution of peroxide. Below the mixed layer, concentrations decrease below the method employed on this cruise.

A modification of the POHPAA method has been developed which takes advantage of the hydrophobic nature of the POHPAA dimer in acidified seawater. Reverse phase chromatography was used for concentration of a 50 ml sample containing the fluorescent signal into a 5 ml volume using a C¹⁸ column. Rinsing of isolated dimer to remove Mg and eluting with KOH allows measurement at a pH which maximizes the dimer fluorescence (pH > 10) without precipitation of magnesium hydroxide, a sensitivity limitation of this method in seawater as previously employed. The limit of detection, represented by three times the standard deviation of triplicate blank determinations, is 0.2 nM. Automation of the isolation and elution of the POHPAA dimer and use of HPLC to maximize experimental parameters show promise for increased sensitivity. This method should allow examination of peroxide in environments where levels are < 5 nM.

References

- Martin, J.H. and S.E. Fitzwater (1988). Iron deficiency limits phytoplankton growth in the northeast Pacific subarctic. *Nature*, **331**: 341-343.

- Martin, J.H. and R.M. Gordon (1988). Northeast Pacific iron distributions in relation to phytoplankton productivity. *Deep-Sea Res.*, **35**(2): 177-196.
- Miller, W.L. and D.R. Kester (1988). Hydrogen peroxide measurement in seawater by (p-hydroxyphenyl)acetic acid dimerization. *Anal. Chem.*, **60**: 2711-2715.
- Moffett, J.W. and R.G. Zika (1987). Reaction kinetics of hydrogen peroxide with copper and iron in seawater. *Environ. Sci. Technol.*, **21**(8): 804-810.

10.9 Abiotic Formation of Formaldehyde, Acetaldehyde and Glyoxylate from UV-B Induced Photodegradation of Humic Substances in Natural Waters

Kenneth Mopper and Robert J. Kieber
University of Miami
Rosenstiel School of Marine and Atmospheric Science
Division of Marine and Atmospheric Chemistry
4600 Rickenbacker Causeway
Miami, Florida 33149-1098

Introduction

A variety of photochemical reactions are known to occur in natural waters. However, little is known about the mechanisms and rates of these reactions, the wavelengths responsible, the precursors, or the products formed. Several studies have postulated that low molecular weight, biologically labile compounds are photochemically produced from the biologically refractory (non-utilizable) portion of dissolved organic matter (DOM) in natural waters (Kieber et al., 1989). This has important ramifications with respect to geochemical cycling of organic carbon in natural waters since it provides a removal pathway for this otherwise recalcitrant material. Here, we present new data on rates of photochemical production of low molecular weight (LMW) organic compounds from humic substances in natural waters. We use these results to estimate the residence times of deep sea DOC and riverine DOC in the ocean.

Experimental

Samples were irradiated in quartz flasks with natural sunlight (4 h, solar noon, cloudless sky, 26°N). Time course experiments showed that production rates were linear during irradiations. The near UV solar flux was measured with an Epply Radiometer (Model TUVB) equipped with a visible light cut-off filter (>385 nm absorbed). Unfiltered and 0.2 μm filtered open ocean and coastal seawater were used in most experiments. Filtration had no significant effect on photoproduction rates, which is in agreement with past studies. Dark controls showed no detectable increase in carbonyl concentrations. Carbonyl compounds were determined as 2,4-dinitrophenylhydrazones using HPLC with absorbance detection (Mopper and Stahovec, 1986).

Apparent quantum yields were determined using a Kratos-Schoeffel irradiation system with a 1000 W continuous output xenon lamp and a YSI-Kettering radiometer (the bandwidth was 5 nm). Irradiations were performed for 2–8 h at room temperature using a 10 cm quartz cell. The light flux was measured with a standard ferric oxalate actinometer. Data are presented as apparent quantum yields, i.e., molecules of analyte formed per photon absorbed, instead of true quantum yields because humic substances do not have a defined molecular weight (Cooper et al., 1988). Apparent quantum yields were normalized to the solar downward irradiance spectrum incident at the sea surface (sun zenith angle 20°; ozone = 0.28 atm-cm) during summer at 26°N using a model of Smith and Baker (1979).

Table 10.9.1: Net Photochemical Production Rates (\pm SD) of Formaldehyde, Acetaldehyde and Glyoxylate in Natural Water Samples.

Sample	Photoproduction (nM/W-h/m ²) ^a		
	Formaldehyde	Acetaldehyde	Glyoxylate
Everglades (n = 3)	233 \pm 20	186 \pm 20	383 \pm 36
Orinoco River (n = 3)	90 \pm 10	71 \pm 10	83 \pm 4
Biscayne Bay (n = 3)	16 \pm 10	20 \pm 7	17 \pm 4
Windward Passage (n = 1)	6	6	5
Sargasso Sea (deep) (n = 4)	6.4 \pm 1.5	3.9 \pm 1.1	6 \pm 1.0
Sargasso Sea (surface) (n = 4)	2.2 \pm 0.9	1.2 \pm 1.1	2 \pm 1.0

^aOne watt-hour/m² (W-h/m²) is equivalent to about 3 hours of midday irradiation at subtropical latitudes.

These normalized plots reveal the wavelengths in the solar spectrum responsible for the observed photochemical productions and transformations.

Results and Discussions

Carbonyl compounds, formaldehyde and acetaldehyde, and the α -keto acid glyoxylate were produced in a wide variety of natural waters upon irradiation with sunlight. Photoproduction rates were greatest for inland and coastal waters and least for open ocean waters (Table 10.9.1). The rate of production was linearly related ($r^2 > 0.98$) to initial absorbance at 300 nm and initial fluorescence (excitation 360 nm; emission 460 nm) in all waters tested (Figure 10.9.1). Photochemical production was also linearly related to loss in absorbance and fluorescence (photobleaching) during irradiation. These results were attributed to absorption of light by humic and fulvic substances in the waters, as determined by experiments where purified humic and fulvic extracts from various sources were added to open ocean water. The photochemical reactivities of these different humic extracts, with respect to carbonyl photoproduction, were indistinguishable from each other and from the DOM naturally present in the waters. We conclude that similar chromophores and/or photochemical pathways must be involved in photochemical production of carbonyls from aquatic humic substances, regardless of the origin of these substances (i.e., marine or terrestrial).

Sunlight normalized quantum yields for photoproduction of LMW carbonyls in natural waters showed that the photoactive wavelengths are restricted to a narrow band in the UV-B region of 290–315 nm (Figure 10.9.2). We found that these wavelengths are also responsible for photobleaching of DOM absorbance (Figure 10.9.3) and for photoproduction of the highly reactive hydroxy radicals in natural waters (Figure 10.9.2). These results suggest that

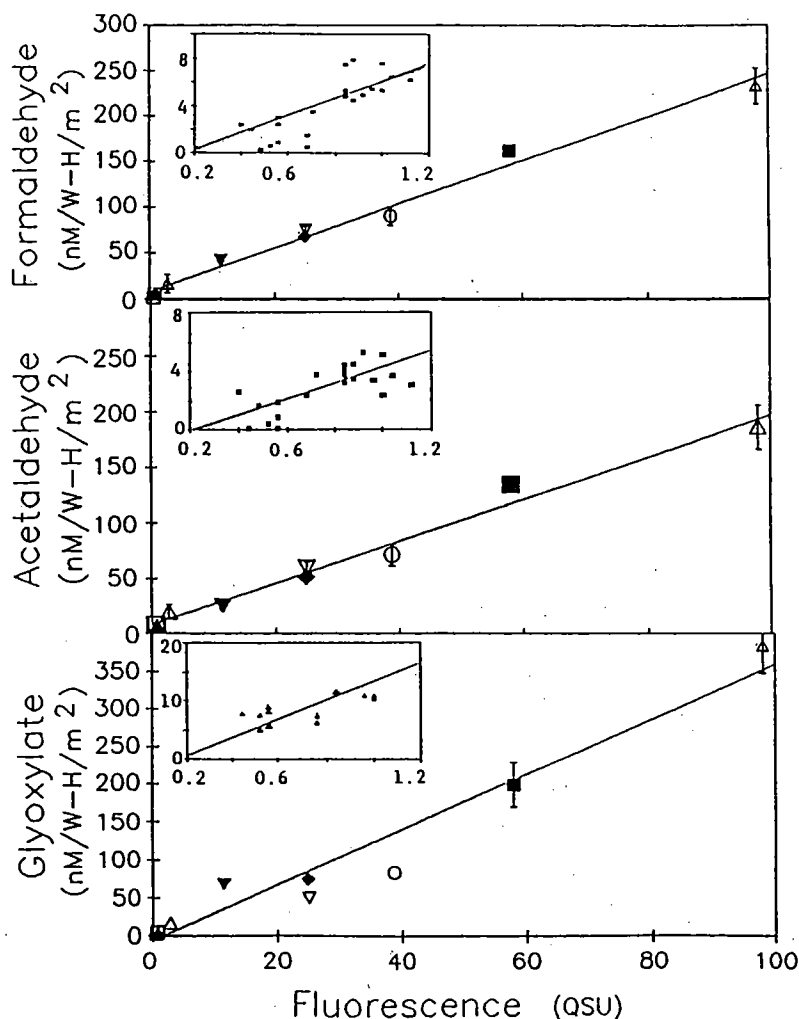

Figure 10.9.1: Sunlight-induced photoproduction of formaldehyde, acetaldehyde and glyoxylate as a function of initial fluorescence (excitation 360, emission 460) in a variety of natural waters. The insets are magnifications of data points near the origins. The greater scatter in the latter data sets is probably due to greater analytical uncertainty at low fluorescences. **Notation:** (Δ) Everglades freshwater; (\blacksquare , \diamond) Everglades freshwater (1:1, 1:5 with Sargasso seawater); (\circ) Orinoco River water; (\blacklozenge , \blacktriangledown) Orinoco River water (1:1, 1:5 with Sargasso seawater); (\triangle) Biscayne Bay seawater; (\square) Sargasso Sea surface waters; (\blacktriangle) Windward Passage surface seawater. Filled circles (\bullet) are humic and fulvic extracts (dissolved in Sargasso Sea surface waters) in order of decreasing absorbances: Suwannee River fulvic acid; Suwannee River humic acid; soil humic acid; soil fulvic acid; marine humic substance extracted from Caribbean Sea surface water with a C-18 cartridge; XAD-8 extracted marine fulvic acid; XAD-2 extracted marine fulvic acid; XAD-8 extracted marine humic acid; marine humic substance extracted from Florida current surface water with a C-18 cartridge.

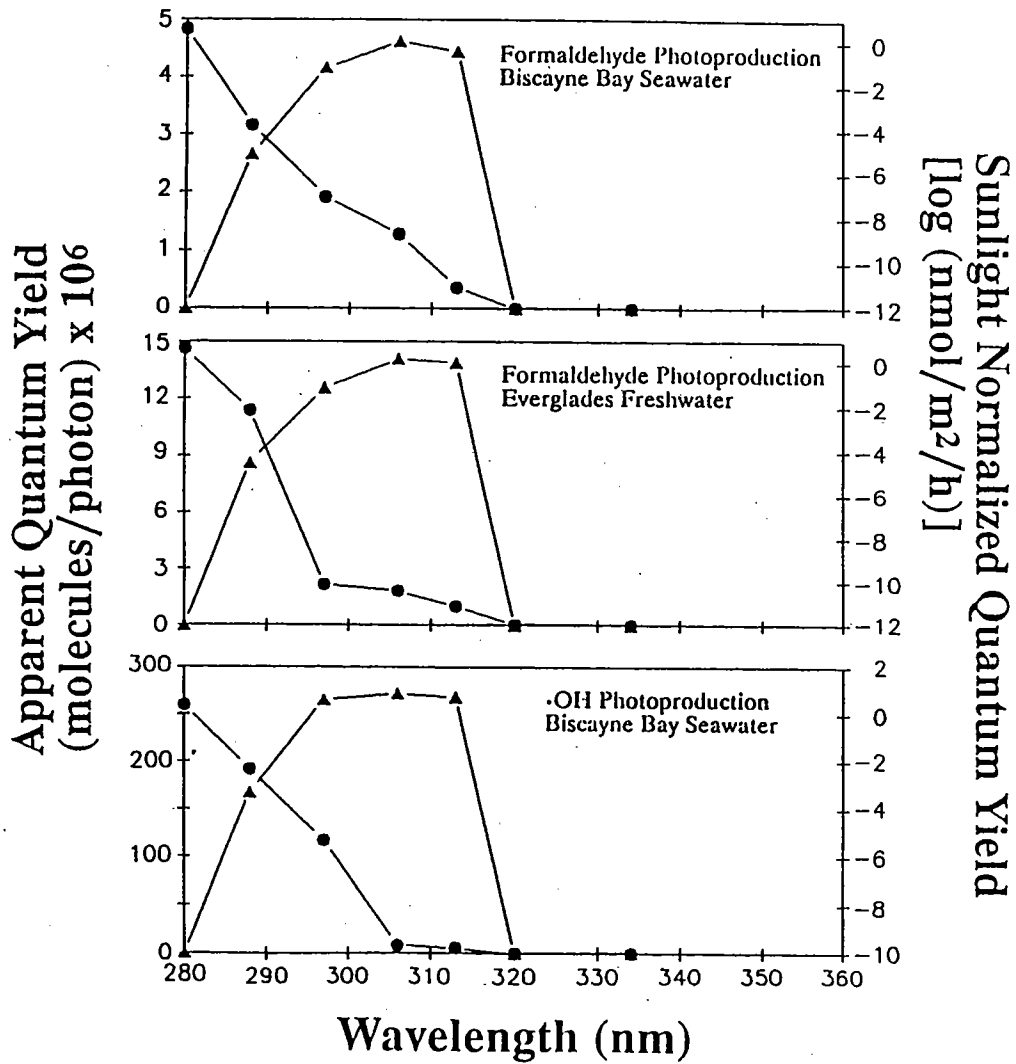

Figure 10.9.2: (●) Apparent quantum yield for formaldehyde and hydroxy radical production in natural waters as a function of irradiation wavelength (5 nm bandwidth). (▲) Quantum yields normalized to the downward solar irradiance spectrum incident at the sea surface.

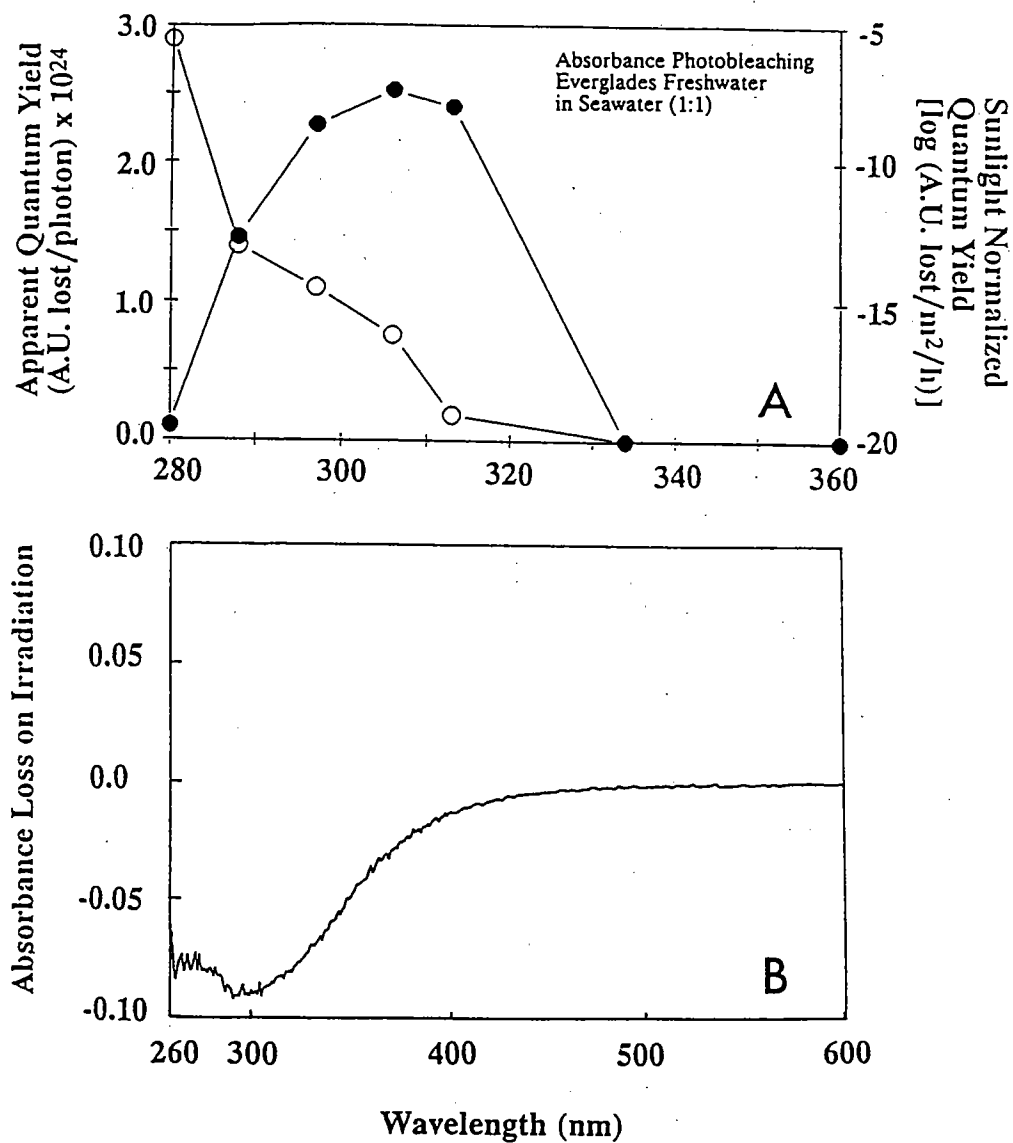

Figure 10.9.3: (A) (○) Apparent quantum yield for photobleaching of absorbance in Everglades water (mixed 1:1 with Sargasso seawater) as a function of irradiation wavelength (5 nm bandwidth). (●) Quantum yields normalized to the downward solar irradiance spectrum incident at the sea surface. (B) Difference in absorption spectra before and after irradiation of Orinoco River water. Negative values indicate a net loss in absorbance after 4 h irradiation in sunlight.

photoproduction of carbonyls from humic substances is closely related to photoproduction of hydroxy radicals and to photobleaching of absorbance.

Significance in Oceanic Organic Carbon Cycling

Several studies have indicated that the oceanic carbon budget is not in balance with respect to riverine carbon inputs (Mantoura and Woodward, 1983; Deuser, 1988). Based on the latter inputs alone, the entire DOM content of the oceans can be accounted for in about 600–2000 years. But, deep sea DOC has a ^{14}C age of 6200 years (Williams and Druffel, 1987) and shows little terrestrial character (Meyers-Schulte and Hedges, 1986). Thus, the contribution of riverine DOM to the oceanic pool of DOM, especially in the deep sea, appears to be negligible. Therefore, there must exist a major unknown sink(s) for rapid removal of riverine DOM from the oceans. We are currently testing the hypothesis that photochemical/biological degradation and oxidation of humic substances is a major removal pathway for this carbon (Kieber et al., 1989). Based on the photochemical rates found in the present study (Table 10.9.1), we estimate that deep sea DOC has a residence time of about 6000 years, which is close to the measured ^{14}C age (Williams and Druffel, 1987) and that the annual riverine DOC input would have a residence time of only about seven years in the oceanic mixed layer (Mopper et al., in preparation). Thus, from these estimates it would appear that the contribution of riverine DOC to the deep sea is small, which is in agreement with the molecular evidence of Meyers-Schulte and Hedges (1986).

Conclusions

Photoreactivities of humic substances from widely varying sources (marine and terrestrial) are very similar with respect to carbonyl production, suggesting that similar chromophores or photochemical pathways are involved in this production.

Photoproduction of LMW carbonyls and other "fragments" appears to be strongly related to photobleaching of absorbance by humics and possibly to $\cdot\text{OH}$ production. UV-B wavelengths are exclusively responsible for these processes. In contrast, photobleaching of humic fluorescence (Kouassi, 1986), and photoproduction of triplet photosensitizers (Zepp et al., 1985), H_2O_2 (Cooper et al., 1988) and CO (R.D. Jones, personal communication) from humics involve also lower energy light-initiated processes.

Photodegradation appears to be partly responsible for the slow, geochemical turnover of biologically refractory DOM, i.e., humic substances, in the ocean. Furthermore, photodegradation may rapidly remove most riverine DOM before it can mix into the deep sea.

References

- Cooper, W.J., R.G. Zika, R.G. Petasne and J.M.C. Plane (1988). Photochemical formation of H_2O_2 in natural waters exposed to sunlight. *Environ. Sci. Technol.*, **22**: 1156–1160.
- Deuser, W.G. (1988). Whither organic carbon? *Nature*, **332**: 396–397.

- Kieber, D.J., J.A. McDaniel and K. Mopper (1989). Photochemical source of biological substrates in seawater: Implications for geochemical carbon cycling. *Nature*, **341**: 637-639.
- Kouassi, A.M. (1986). *Light Induced Alteration of the Photophysical Properties of Dissolved Organic Matter in Seawater*. M.S. thesis, University of Miami, 148 pp.
- Mantoura, R.F.C. and E.M.S. Woodward (1983). Conservative behavior of the riverine dissolved organic carbon in the Severn Estuary: Chemical and geochemical implications. *Geochim. Cosmochim. Acta*, **47**: 1293-1309.
- Meyers-Schulte, K.K. and J.I. Hedges (1986). Molecular evidence for a terrestrial component of organic matter dissolved in ocean water. *Nature*, **321**: 61-63.
- Mopper, K. and W.L. Stahovec (1986). Sources and sinks of low molecular weight organic carbonyl compounds in seawater. *Mar. Chem.*, **19**: 305-321.
- Smith, R.C. and K.S. Baker (1979). Penetration of UV-B and biologically effective dose-rates in natural waters. *Photochem. Photobiol.*, **29**: 311-323.
- Williams, P.M. and E.R.M. Druffel (1987). Radiocarbon in dissolved organic matter in the central North Pacific Ocean. *Nature*, **330**: 246-248.
- Zepp, R.G., P.F. Schlotzhauer and R.M. Sink (1985). Photosensitized transformations involving electronic energy transfer in natural waters: Role of humic substances. *Environ. Sci. Technol.*, **19**: 74-81.

10.10 Light-Dependent Degradation of Phytoplankton Pigments

James R. Nelson
Skidaway Institute of Oceanography
P.O. Box 13687
Savannah, Georgia 31416

Rates of degradation of phytoplankton chlorophylls and carotenoids under visible light were determined in laboratory experiments, using killed cells as a source of pigments. Chlorophylls and carotenoid concentrations were determined by HPLC analyses, and spectral absorption measurements (750–350 nm) were made for particulate material retained on glass-fiber filters. Incubations were carried out for aerated and N₂-bubbled samples under light and dark conditions.

Pigment degradation was light- and oxygen-dependent and was first-order with respect to light exposure. Rates of photodegradation of carotenoids were comparable to, or greater than, those for chlorophylls. This is quite different from the pattern of pigment photodegradation in aerated organic solutions, in which carotenoids are considerably more stable than chlorophyll *a*. It is proposed that this difference results from a photosensitized mechanism of pigment photooxidation in the killed cells. Spectral measurements showed that a more light-stable class of chromophores, which absorb in the blue to near-UV, remained after the chlorophylls and carotenoids had bleached.

10.11 EPR Studies of Hydroxyl Radical Formation from Photolysis of Aqueous Solutions of Humic and Fulvic Acids

Barrie M. Peake and Neil V. Blough
Chemistry Department
Woods Hole Oceanographic Institution
Woods Hole Massachusetts 02543[5mm]

Solar irradiation of aqueous solutions of humic substances has been known for many years to give rise to relatively simple EPR spectra from unidentified free radicals (Choudry, 1984). Recently these have been shown to scavenge added nitroxide radicals at rates dependent upon both the presence of O₂ and the charge on the nitroxide (Blough, 1988).

In order to further identify the nature of these photo-induced radicals, we wish to report the use of EPR and the spin trap 5,5-dimethyl-1-pyrroline N-oxide (DMPO) to detect the formation of OH radicals from the UV-vis photolysis of aqueous solutions of a wide range of humic and fulvic acid:

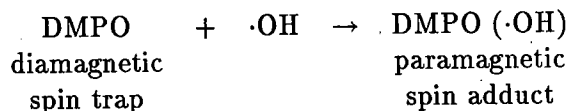

The rate of formation and the steady-state concentration of the DMPO ($\cdot\text{OH}$) spin adduct has been found to depend on a number of factors including the presence of O₂, the excitation wavelength and added scavengers.

The possible origin of these $\cdot\text{OH}$ radicals in these systems will be discussed.

References

- Blough, N.V. (1988). *Environ. Sci. Technol.*, **22**: 77.
- Choudry, G.G. (1984). In: *Humic Substances: Structural, Photophysical and Free Radical Aspects and Interactions with Environmental Chemicals, Current Topics in Environmental and Toxicological Chemistry*, Gordon and Breach, New York, Chapter 7.

10.12 Biological Effects of Ozone Depletion on Antarctic Aquatic Environments

**Mary A. Voytek
Environmental Defense Fund
1616 P St., N.W.
Washington, D.C. 20036**

Research in Antarctica is becoming increasingly important to understanding global processes and plays a unique role in the management of global environmental problems. Over the last decade, increased fluxes of ultraviolet (UV) radiation have occurred in Antarctica as a result of an annual, seasonal depletion in stratospheric ozone. Antarctic aquatic environments are providing natural laboratories for the study of UV effects on biogeochemical processes. However, most research to date has focused on the atmospheric processes responsible for ozone depletion and only a few investigations have specifically addressed UV effects on the aquatic biosphere and none on the chemosphere. Preliminary experiments in Antarctica indicate that the marine phytoplankton are already UV stressed and investigations from other regions further suggest that other components of aquatic ecosystems are very susceptible to increased UV exposure. Using information from these studies and available information on distribution and trophic dynamics of Antarctic species, potential impacts can be identified and areas for further research can be highlighted. Recommended actions for the international scientific community are set out to provide the necessary ecological information for sound policymaking in order to expedite the adoption of measures to protect Antarctica's resources.

10.13 Photochemistry of the Eastern Caribbean

**Oliver C. Zafriou
Chemistry Department
Woods Hole Oceanographic Institution
Woods Hole, Massachusetts 02543**

In 1988, one of the first large coordinated studies of photochemical processes in the marine environment was carried out in the Eastern Caribbean Basin, whose surface waters are seasonally strongly influenced by riverine input from two of the world's largest rivers, the Amazon and the Orinoco. This poster summarizes the principal objectives of this work, which was to understand the impact of large river systems on the photochemistry of the eastern Caribbean. Objectives, measurements made, methods used, and the PI's and their affiliations are summarized.

10.14 Photosensitized Formation of Carbonyl Sulfide in Sea Water**R.G. Zepp¹ and M.O. Andreae²****¹Environmental Research Laboratory
U.S. Environmental Protection Agency
Athens, Georgia 30613****²Max Planck Institute for Chemistry
P.O. Box 3060, D-6500 Mainz
Federal Republic of Germany**

Carbonyl sulfide (COS) in the atmosphere is derived primarily from the photochemical oxidation of the dissolved organic matter in sea water (Ferek and Andreae, 1984). Our study indicates that COS formation results from the photosensitized oxidation of organosulfur compounds, including mercaptans such as cysteine, that do not directly absorb sunlight. Because rates of photosensitized reactions are generally much more rapid in coastal waters than in the open sea, these results help to explain why concentrations of COS have been observed to be highest in coastal/shelf regions. Other results indicate that dissolved organic matter (DOM) isolated from rivers that drain into coastal areas (e.g., the Suwannee River, a Florida river that flows into the Gulf of Mexico) photosensitizes the oxidation of organosulfur compounds to COS in sea water. The formation of COS in synthetic sea water containing Suwannee River DOM and in sea water samples (North Sea, Baltic Sea) was shown to be primarily induced by the ultraviolet-B (280–320 nm) portion of solar radiation. Using monochromatic radiation, we found relative rates of COS formation in a coastal water sample from the North Sea to be 1.0 at 300 nm, 0.27 at 310 nm, 0.16 at 320 nm, 0.029 at 330 nm. Computer simulations based on an action spectrum constructed from these rates suggest that, with all other factors constant, stratospheric ozone depletion may result in increased fluxes of COS from this part of the sea (about 0.7% increase/1% decrease in ozone).

References

- Ferek, R.J. and M.O. Andreae (1984). Photochemical production of carbonyl sulfide in marine surface waters. *Nature*, **307**: 148–150.

APPENDIX I

PROGRAM

Appendix I - Program

Workshop on Effects of Solar Ultraviolet Radiation on Biogeochemical Dynamics in Aquatic Environments

All Talks in Whitman Auditorium

Sunday, October 22

1:00 to 9:00 p.m. Registration, Swope Center, MBL.

Monday, October 23

7:00-8:30 a.m. Breakfast, Registration

Introduction: UV Radiative Transfer Modeling, Remote Sensing

Discussion Leader: P. J. Crutzen

- | | |
|-----------------|---|
| 8:30 | R. Zepp, E. Green, Introduction |
| 8:40 | P. G. Brewer |
| 8:55 | P. D. Guthrie
<i>"The Distribution of Ozone in the Atmosphere"</i> |
| 9:20 | A. M. Thompson
<i>"Perturbations to UV Incident on Southern Hemisphere
Oceans Following Breakup of the Antarctic Ozone Hole"</i> |
| 9:45 | D. A. Randall
<i>"How Might the Distributions of Cloudiness Change in
Response to Global Warming"</i> |
| 10:10 | Break |
| 10:25 | S. Madronich
<i>"Changes in Biologically Damaging Ultraviolet (UV)
Radiation: Effect of Overhead Ozone and Cloud Amount"</i> |
| 10:50 | K. L. Carder
<i>"Remote Sensing of Marine Humus"</i> |
| 11:15 | K. S. Baker
<i>"Penetration of UV-B into Aquatic Systems and Possible
Influence on Phytoplankton Communities"</i> |
| 11:40 | Discussion |
| 12:10-1:30 p.m. | Lunch |

**Field Observations of UV Effects on
Chemical Processes in Natural Waters**

Discussion Leader: P. G. Brewer

- 1:30 M. O. Andreae
*"Photochemical Production of Carbonyl Sulfide
in Coastal and Open Ocean Waters"*
- 1:55 R. Gammon
*"Photochemical Production of Carbon Monoxide in
Surface Waters of the Pacific and Indian Oceans"*
- 2:25 R. Zika
*"Hydrogen Peroxide as a Relative Indicator of the
Photochemical Reactivity of Natural Waters"*
- 2:45 O. C. Zafiriou
*"Effects of Solar UV Radiation on Geochemical
Dynamics: State-of-the-Art in Molecular Probes
for Reactive Transients"*
- 3:10 **Break**
- 3:25 D. R. Kester
*"The Role of Photochemical Processes and Hydrogen
Peroxide in Iron Redox Chemistry"*
- 3:50 J. W. Moffett
*"Chemical Reactions Affected by UV Radiation in the
Oceans and Their Influence on Primary Productivity;
Some General Considerations"*
- 4:15 D. G. Crosby
"Phototransformation of Chemicals in Rice Paddies"
- 4:40 Discussion
- 6:00-7:30 **Dinner**

Tuesday, October 24

7:00-8:30 a.m. Breakfast

**UV Effects on Atmospheric Chemistry
in Condensed Phases***Discussion Leader: S. Madronich*

- 8:30 R. J. Crutzen
*"Influence of Cloud Photochemical Processes on
Tropospheric Ozone"*
- 8:55 P. H. Wine
*"Laboratory Investigations of Atmospheric Dimethyl-
sulfide Oxidation"*
- 9:20 P. Warneck
*"Laboratory Studies Related to the Aqueous Chemistry
of Clouds"*
- 9:45 B. C. Faust
*"Aqueous-Phase Photochemical Sources of Oxidants in
Clouds"*
- 10:10 **Break**
- 10:25 M. R. Hoffmann
*"Heterogeneous Photocatalysis on the Surface of Metal
Oxides"*
- 10:50 Discussion

UV Effects on Homogeneous Chemical Processes*Discussion Leader: O. C. Zafiriou*

- 11:15 R. Zepp
*"Effects of Solar UV Radiation on the Oxidation and
Reduction of Organic Substances in Water"*
- 11:40 N. V. Blough
*"Optical Detection of Photogenerated Free Radical
Intermediates in Natural Waters"*
- 12:05-1:30 **Lunch**

- 1:30 J. Ertel
*"Photochemistry of Dissolved Organic Matter:
An Organic Geochemical Perspective"*
- 1:55 W. R. Haag
*"Survey of Sunlight-Produced Transient Reactants
in Surface Waters"*
- 2:20 T. Mill
*"Estimated Effects of Indirect Photolysis on Marine
Organisms"*
- 2:45 G. Helz
"Photoreduction of Chromium in Natural Waters"
- 3:10 **Break**
- 3:25 Y. Skurlatov
*"Effects of Solar UV Radiation on Hydrogen Peroxide
Content and Radical Self-Purification Processes in
Surface Natural Waters"*
- 3:50 Discussion

UV Effects on Heterogeneous Chemical Processes

Discussion Leader: R. Zika

- 4:30 T. D. Waite
*"Photoprocesses Involving Colloidal Iron and Manganese
Oxides in Aquatic Environments"*
- 4:55 G. Miller
"Photolysis of Contaminants on Soils and Sediments"
- 6:00–7:30 **Dinner**
- 7:30–9:00 Mixer/Poster Session

Wednesday, October 25

7:00 to 8:30 a.m. Breakfast

UV Effects on Heterogeneous Chemical Processes
(continued)

Discussion Leader: R. Zika

- 8:30 W. G. Sunda
*"Effects of Sunlight and Anthropogenic Alterations
in Atmospheric Solar Attenuation on Manganese
Redox Cycles in Surface Seawater"*
- 8:55 P. H. Nelson
*"Sunlight-Dependent Changes in the Pigment Content
and Spectral Characteristics of Particulate
Organic Material Derived from Phytoplankton"*
- 9:20 F. M. M. Morel
"Indirect Effects of UV Radiation on Phytoplankton"
- 9:45 Discussion
- 10:15 **Break**

UV Effects on Biological Processes

Discussion Leader: T. P. Coohill

- 10:30 T. P. Coohill
*"Role in Estimating Effects Due to Stratospheric
Ozone Depletion"*
- 10:55 R. A. Larson
*"UV-B Effects on Plants, Herbivores, and Phyto-
pathogens"*
- 11:20 R. C. Smith
*"Penetration of UV-B and Biochemically Weighted
Dose-Rates into Aquatic Systems"*
- 11:45-1:30 **Lunch**

1:30	T. A. Dahl <i>"Photosensitization and Singlet Oxygen Toxicity"</i>
1:55	R. Wever <i>"Bromoform Production by Marine Macroalgae: The Role of Vanadium Peroxidases"</i>
2:20	H. Gucinski <i>"Dimethylsulfide Production — Effects of UV-B and PAR on Heterogeneous Phytoplankton Populations"</i>
2:45	Break
3:00	G. Dohler <i>"Impact of UV-B (290–320 nm) Radiation on Metabolic Processes of Marine Phytoplankton"</i>
3:25	B. G. Mitchell <i>"Ultraviolet Radiation in Antarctic Waters: Particu- late Absorption and Effects on Photosynthesis"</i>
3:50	D. Karentz <i>"Ecological Considerations of the Antarctic Ozone Hole in the Marine Environment"</i>
4:15–5:00	Discussion
7:00–9:00	Banquet

Thursday, October 26

8:30 to 11:00 a.m. Group Discussions – Future Research Needs

Abstracts In Absentia

A. E. S. Green	<i>"Ozone Depletion and Greenhouse Warming"</i>
J. F. Power	<i>"Laser Thermo-optical Methodologies for Environmental Analysis"</i>
K. Mopper and X.-L. Zhou	<i>"Photochemical Production of Hydroxyl Radicals and Other High Energy Transients at the Sea Surface"</i>
K. Mopper and R. J. Kieber	<i>"Abiotic Formation of Formaldehyde, Acetaldehyde, and Glyoxylate from UV-B Induced Photodegradation of Humic Substances in Natural Waters"</i>

APPENDIX II

LIST OF ATTENDEES

Appendix II - List of Attendees

Workshop on Effects of Solar Ultraviolet Radiation on Biogeochemical Dynamics in Aquatic Environments

M.O. Andreae
Max Planck Institute for Chemistry
P.O. Box 3060, D-6500 Mainz
Federal Republic of Germany
Tel: 49-6131-305-420
Fax: 49-6131-305-388

Bruce Baker
AREAL, U.S. EPA
Research Triangle Park, NC 27709
Tel: (919) 541-1326

Michael Behrenfeld
U.S. Environmental Protection Agency
Hatfield Marine Science Center
Newport, OR 97365
Tel: (503) 867-4040

Lars Olof Bjorn
Department of Plant Physiology
University of Lund
Box 7007
S-220 07 Lund
Sweden
Tel: 46-4646-107797

Neil V. Blough
Department of Chemistry
Woods Hole Oceanographic Institution
Woods Hole, MA 02543
Tel: (508) 457-2000, ext. 2641
Fax: (508) 457-2000, ext. 6128

Robert Bowen
SAIC
U.S. Environmental Protection Agency
South Ferry Road
Narragansett, RI 02882
Tel: (401) 782-3097

Peter G. Brewer
Department of Chemistry
Woods Hole Oceanographic Institution
Woods Hole, MA 02543
Tel: (508) 457-2000, ext. 2896
Fax: (508) 457-2000, ext. 6128

Alison Butler
Department of Chemistry
University of California
Santa Barbara, CA 98106
Tel: (805) 961-8178

Ken Carder
Department of Marine Science
University of South Florida
St. Petersburg, FL 33701
Tel: (813) 893-9148
Fax: (813) 893-9189

Thomas P. Coohill
Department of Physics & Astronomy
Western Kentucky University
Bowling Green, KY 42101
Tel: (502) 745-4357

Donald Crosby
Department of Environmental Toxicology
University of California, Davis
Davis, CA 95616
Tel: (916) 752-4529
Fax: (916) 752-3394

Paul Crutzen
Max Planck Institute for Chemistry
P.O. Box 3060, D-6500 Mainz
Federal Republic of Germany
Tel: 49-6131-305-458
Fax: 49-6131-305-388

Thomas Dahl
Department of Pharmacology
Tufts Univ. Medical & Veterinary Schools
136 Harrison Avenue
Boston, MA 02111
Tel: (617) 956-7562/6897

Gunter Döhler
Botanisches Institut
der Universität Frankfurt
Siesmayerstraße 70
D-6000 Frankfurt am Main
Federal Republic of Germany
Tel: 49-69-1798-4245

Sayed Z. El-Sayed
Department of Oceanography
Texas A & M University
College Station, TX 77843
Tel: (409) 845-2134

John Ertel
Department of Geology
University of Georgia
Athens, GA 30602
Tel: (404) 542-1285

Bruce Faust
Forestry & Environmental Studies
Duke University
Durham, NC 22706
Tel: (919) 684-6090
Fax: (919) 684-3200

Richard Gammon
School of Oceanography
University of Washington
Seattle, WA 90195
Tel: (206) 543-4301

Tom Graedel
AT&T Laboratories, Rm. 10-349
Murray Hill, NJ 07974
Tel: (201) 582-5420
Fax: (201) 582-3958

Edward J. Green, Program Manager
Oceanic Chemistry Program, Code 422CB
Office of Naval Research
800 N. Quincy Street
Arlington, VA 22217-5000
Tel: (202) 696-4590

Sarah Green
Department of Chemistry
Woods Hole Oceanographic Institution
Woods Hole, MA 02543
Tel: (508) 457-2000, ext. 3217

Herman Gucinski
Environmental Sciences
NSI Technology Services Corp.
200 Southwest 35th Street
Corvallis, OR 97330
Tel: (503) 757-4794

Paul Guthrie
Code 616
NASA-Goddard Space Flight Center
Greenbelt, MD 20771
Tel: (301) 286-5830

Werner Haag
SRI International
333 Ravenswood Avenue
Menlo Park, CA 94025
Tel: (415) 859-2079

George Helz
Department of Chemistry & Biochemistry
University of Maryland
College Park, MD 20742
Tel: (301) 454-4850

Michael Hoffmann
Engineering & Applied Sciences
William Keck Lab 138-78
California Institute of Technology
Pasadena, CA 91125
Tel: (818) 356-4391

Deneb Karentz
Lab. of Radiobiology-Environmental Health
University of California Medical Center
San Francisco, CA 94143-0750
Tel: (415) 476-2333/4563

David Kieber
Department of Chemistry
Woods Hole Oceanographic Institution
Woods Hole, MA 02543
Tel: (508) 457-2000, ext. 3219

J. Kelly
Ecosystems Research Center
Cornell University
Corson Hall
Ithaca, NY 14853
Tel: (607) 255-3425

Dana Kester
Graduate School of Oceanography
University of Rhode Island
Kingston, RI 02882
Tel: (401) 792-6294

Richard Larson
Institute of Environmental Studies
University of Illinois at Urbana-Champaign
1005 Western Avenue
Urbana, IL 61801
Tel: (217) 333-7269

Henry Lee, II
U.S. EPA, ERL Narragansett
Hatfield Marine Science Center
Newport, OR 07365
Tel: (503) 867-4942

Sasha Madronich
National Center for Atmospheric
Research
Boulder, CO 80307
Tel: (303) 497-1430

Jay Means
42 Atkinson Hall
Institute for Environmental Studies
Louisiana State University
Baton Rouge, LA 70803
Tel: (504) 388-8521

Ted Mill
SRI International
333 Ravenswood Avenue
Menlo Park, CA 84025
Tel: (415) 859-3605

Glenn Miller
Department of Biochemistry
University of Nevada, Reno
Reno, Nevada 89557
Tel: (702) 784-4108

Greg Mitchell
MRD A002
Scripps Institution of Oceanography
University of California, San Diego
La Jolla, CA 92093
Tel: (619) 534-2687

James Moffett
Department of Chemistry
Woods Hole Oceanographic Institution
Woods Hole, MA 02543
Tel: (508) 457-2000, ext. 3218
Fax: (508) 457-2000, ext. 6128

Francois Morel
Department of Civil Engineering
Building 48-423
Massachusetts Institute of Technology
Cambridge, MA 02139
Tel: (617) 253-3726

Wayne Munns
SAIC/EPA
South Ferry Road
Narragansett, RI 02882
Tel: (401) 782-3043

James Nelson
Skidaway Institute of Oceanography
P.O. Box 13687
Savannah, GA 31406
Tel: (912) 356-2473

Barrie M. Peake
Chemistry Department
University of Otago
Box 56
Dunedin, New Zealand

Joseph Pinto
AREAL
U.S. Environmental Protection Agency
Research Triangle Park, NC 27709
Tel: (919) 541-2183

John Sigmon
U.S. EPA (RD-682)
401 M Street, SW
Washington, D.C. 20460
Tel: (202) 382-5738

Yurii Skurlatov
Institute of Chemical Physics
USSR Academy of Sciences
4 Ulitsa Kosygina
Moscow, U.S.S.R.
Tel: 939-24-26 or 939-72-17

Ray Smith
CSL/CRSEO
University of California, Santa Barbara
Santa Barbara, CA 98106
Tel: (805) 961-4709
Omnet: R.SMITH.UCSB

Richard L. Steele
U.S. Environmental Protection Agency
Environmental Research Laboratory
South Ferry Road
Narragansett, RI 02882
Tel: (401) 782-3000

William Sunda
NMFS/NOAA
Beaufort Laboratory
Beaufort, NC 28516
Tel: (919) 728-8754

Anne M. Thompson
Code 916
NASA-Goddard Space Flight Center
Greenbelt, MD 20771
Tel: (301) 286-2629

Jan C. van der Leun
Institute of Dermatology
University Hospital of Utrecht
Heidelberglaan 100
NL-3584 CX Utrecht
The Netherlands
Tel: 31-30-50-7386

Mary Voytek
Environmental Defense Fund
1616 P Street, NW
Washington, DC 20036
Tel: (202) 387-3500

D. Vucelic
Beograd University
Department of Physical Chemistry
Studentski trg. 122-POB 551
Beograd
Yugoslavia

T. David Waite
ANSTO
Private Mail Bag 1
Menai, NSW 2234
Australia
Tel: 61-2-5433896
Fax: 61-2-5437536

Henry A. Walker
U.S. Environmental Protection Agency
Environmental Research Laboratory
South Ferry Road
Narragansett, RI 02882
Tel: (401) 782-3134

Peter Warneck
Max Planck Institute for Chemistry
Saarstr. 23, 6500 Mainz
Federal Republic of Germany
Tel: 49-6131-305465

C. Susan Weiler
224 N. Bellevue Avenue
Walla Walla, WA 99362
Tel: (509) 522-1637

Ron Wever
Laboratory of Biochemistry
University of Amsterdam
P.O. Box 20151
1000HD Amsterdam
The Netherlands
Tel: 31-20-525-5110

Oliver Zafriou
Department of Chemistry
Woods Hole Oceanographic Institution
Woods Hole, MA 02543
Tel: (508) 457-2000, ext. 2342
Fax: (508) 457-2000, ext. 6128

Richard Zepp
U.S. Environmental Protection Agency
Environmental Research Laboratory
College Station Road
Athens, GA 30613-7799
Tel: (404) 546-3428

Xian Liang Zhou
RSMAS-MAC
University of Miami
4600 Rickenbacker Causeway
Miami, FL 33149-1098
Tel: (305) 361-4723

Rod Zika
Rosenstiel School of Marine and
Atmospheric Science
University of Miami
4600 Rickenbacker Causeway
Tel: (305) 361-4715

Contributors Unable to Attend

K.S. Baker
Scripps Institution of Oceanography
A-018
University of California, San Diego
La Jolla, CA 92093

Alex E.S. Green
ICAAS-CCTL
University of Florida
Gainesville, FL 32611

Kenneth Mopper
Rosenstiel School of Marine and
Atmospheric Science
4600 Rickenbacker Causeway
Miami, FL 33149-1098

Joan F. Power
Department of Chemistry
McGill University
Montreal, Quebec H3A 2K6
Canada

David A. Randall
Department of Atmospheric Science
Colorado State University
Fort Collins, CO 80523

Paul H. Wine
Molecular Sciences Branch
Georgia Tech Research Institute
Georgia Institute of Technology
Atlanta, GA 30332

DOCUMENT LIBRARY

January 17, 1990

Distribution List for Technical Report Exchange

Attn: Stella Sanchez-Wade
Documents Section
Scripps Institution of Oceanography
Library, Mail Code C-075C
La Jolla, CA 92093

Hancock Library of Biology &
Oceanography
Alan Hancock Laboratory
University of Southern California
University Park
Los Angeles, CA 90089-0371

Gifts & Exchanges
Library
Bedford Institute of Oceanography
P.O. Box 1006
Dartmouth, NS, B2Y 4A2, CANADA

Office of the International
Ice Patrol
c/o Coast Guard R & D Center
Avery Point
Groton, CT 06340

NOAA/EDIS Miami Library Center
4301 Rickenbacker Causeway
Miami, FL 33149

Library
Skidaway Institute of Oceanography
P.O. Box 13687
Savannah, GA 31416

Institute of Geophysics
University of Hawaii
Library Room 252
2525 Correa Road
Honolulu, HI 96822

Marine Resources Information Center
Building E38-320
MIT
Cambridge, MA 02139

Library
Lamont-Doherty Geological
Observatory
Columbia University
Palisades, NY 10964

Library
Serials Department
Oregon State University
Corvallis, OR 97331

Pell Marine Science Library
University of Rhode Island
Narragansett Bay Campus
Narragansett, RI 02882

Working Collection
Texas A&M University
Dept. of Oceanography
College Station, TX 77843

Library
Virginia Institute of Marine Science
Gloucester Point, VA 23062

Fisheries-Oceanography Library
151 Oceanography Teaching Bldg.
University of Washington
Seattle, WA 98195

Library
R.S.M.A.S.
University of Miami
4600 Rickenbacker Causeway
Miami, FL 33149

Maury Oceanographic Library
Naval Oceanographic Office
Bay St. Louis
NSTL, MS 39522-5001

Marine Sciences Collection
Mayaguez Campus Library
University of Puerto Rico
Mayaguez, Puerto Rico 00708

Library
Institute of Oceanographic Sciences
Deacon Laboratory
Wormley, Godalming
Surrey GU8 5UB
UNITED KINGDOM

The Librarian
CSIRO Marine Laboratories
G.P.O. Box 1538
Hobart, Tasmania
AUSTRALIA 7001

Library
Proudman Oceanographic Laboratory
Bidston Observatory
Birkenhead
Merseyside L43 7 RA
UNITED KINGDOM

REPORT DOCUMENTATION PAGE	1. REPORT NO. WHOI-90-09	2.	3. Recipient's Accession No.
4. Title and Subtitle Effects of Solar Ultraviolet Radiation on Biogeochemical Dynamics in Aquatic Environments		5. Report Date January, 1990	
7. Author(s) N. V. Blough and R.G. Zepp		6.	
9. Performing Organization Name and Address The Woods Hole Oceanographic Institution Woods Hole, Massachusetts 02543		8. Performing Organization Rept. No. WHOI 90-09	
12. Sponsoring Organization Name and Address Funding was provided by the Environmental Protection Agency through an Assistance Agreement (CR-816171-01-0) and the Office of Naval Research through Grant Number N00014-90-J-1154.		10. Project/Task/Work Unit No.	
15. Supplementary Notes This report should be cited as: Woods Hole Oceanog. Inst. Tech. Rept., WHOI-90-09.		11. Contract(C) or Grant(G) No. (C) CR-816171-01-0 (G) N00014-90-J-1154	
16. Abstract (Limit: 200 words) This workshop assembled a diverse group of experts, including atmospheric chemists and physicists and aquatic chemists, biochemists and biologists to address the possible ramifications of changing Ultraviolet levels on biogeochemical dynamics of aquatic environments. To address the questions, the workshop was organized around six sessions of oral presentations: <ol style="list-style-type: none"> 1. UV Radiative Transfer, Modeling and Remote Sensing 2. UV Effects on Atmospheric Chemistry in Condensed Phases 3. Field Observations of UV Effects on Chemical Processes in Natural Waters 4. UV Effects on Homogeneous Chemical Processes 5. UV Effects on Heterogeneous Chemical Processes 6. UV Effects on Biological Processes In addition, a poster session allowed participants an opportunity to present their results in more detail. This report presents the written summaries of the Rapporteurs as well as the extended abstracts of the oral and poster presentations, which provided the basis for the Rapporteurs' conclusions.		13. Type of Report & Period Covered Technical Report	
17. Document Analysis a. Descriptors <ol style="list-style-type: none"> 1. UV radiation 2. biogeochemistry 3. aquatic systems b. Identifiers/Open-Ended Terms c. COSATI Field/Group		14.	
18. Availability Statement Approved for publication; distribution unlimited.		19. Security Class (This Report) UNCLASSIFIED	21. No. of Pages 194
		20. Security Class (This Page)	22. Price

