

WHOI-91-34

Copy 2

**Woods Hole
Oceanographic
Institution**



ESOM I and II Final Report

by

Alessandro Bocconcelli, Henri Berteaux, Daniel E. Frye
and Dr. Bryce Prindle

November, 1991

Technical Report

Funding was provided by the Office of Naval Research under
Contract No. N00014-90-J-1719.

Approved for public release; distribution unlimited.

B. PRINDLE

WHOI-91-34

ESOM I and II Final Report

by

Alessandro Bocconcelli, Henri Berteaux, Daniel E. Frye
and Dr. Bryce Prindle

Woods Hole Oceanographic Institution
Woods Hole, Massachusetts 02543

November, 1991

Technical Report

Funding was provided by the Office of Naval Research under
Contract No. N00014-90-J-1719.

Reproduction in whole or in part is permitted for any purpose of the United States
Government. This report should be cited as Woods Hole Oceanog. Inst. Tech. Rept.,
WHOI-91-34.

Approved for public release; distribution unlimited.

Approved for Distribution:



Albert J. Williams 3rd, Chairman
Department of Applied Ocean Physics
and Engineering



ABSTRACT

An Engineering Surface Oceanographic Mooring (ESOM) program was initiated in 1989 by the Woods Hole Oceanographic Institution for the purpose of evaluating the long term, in situ performance of new moored array materials and sensors.

For logistic and practical reasons, a site 12 miles southwest of Bermuda, with a water depth of 3000m was selected to deploy the mooring. Following well established design practice the upper part of the mooring down to a depth of 1900m was made of plastic jacketed, steel armored wire ropes and cables. Groups of test samples were attached at different depths to the main mooring line. The lower part of the mooring was made of compliant, plaited nylon rope.

The mooring was deployed in March 1989. It was recovered and reset, with an acoustic telemetry prototype system, in April 1990. The at-sea phase of the program ended in November 1990 when the termination of a test cable failed and the mooring broke loose. The entire mooring was recovered and all of its samples and components were carefully inspected and tested. In addition to the novel acoustic link, mooring components tested included new wire ropes, new electromechanical cables and their terminations, low drag fairings, fishbite resistant jackets, and a new type of surface buoy. This

report describes the experimental mooring and the results obtained after 18 months of exposure.

ACKNOWLEDGMENTS

The authors wish to acknowledge the support of Dr. Steve Ramberg of the Office of Naval Research (ONR). The personnel at the Bermuda Biological Station for Research (BBSR) provided excellent services, both ashore and at sea. The skippers and crew of the R/Vs ENDEAVOUR, OCEANUS and WEATHERBIRD were instrumental to the success of the project.

Ed Denton and Scott WorriLOW stoically endured a very wet and risky recovery of the ESOM II mooring. Dave Simoneau, Jerry Cotter and John Reese were very helpful during the post-cruise analysis of wire rope and EM samples. Paul Bouchard and Craig Marquette provided valuable information and assistance for the VMCM test. The contribution of Susan Putnam who collected in the field and at sea most of the fishbite data and later produced a computerized fishbite database is gratefully acknowledged. Susan Tarbell processed and plotted most of the telemetered and recorded data during and after the experiment.

We express our gratitude to all the industrial firms that provided wire rope, EM cable and fishbite jacket samples to be tested on the ESOM Project (SAIC, Loos Co., Consolidated, etc.). Al Lucht's

consulting was very constructive in determining the mode and nature of the EM cable failure.

A special thanks to Robert Walden, Patrick O'Malley, Peter Clay, Sean Kery, Cal Eck, John Kemp and John Bouthilette for their contribution to the project. We also acknowledge the talented support of Marcey Youngman for revising and typing the manuscript.

Funding for the production of this report has been provided by the Office of Naval Research under Contract Number N00014-90-J-1719.

The acoustic telemetry work was funded under ONR Contract No. N00014-86-K-0751.

TABLE OF CONTENTS

Abstract.....2
Acknowledgement.....4
Table of Contents.....6
List of Figures.....8
List of Tables.....9
1.0 Introduction.....10
2.0 Test Results.....12
 2.1 Methodology.....12
 2.2 Surface Buoy.....19
 2.3 Wire Rope.....22
 2.4 E/M Cable.....26
 2.5 Fairings.....34
 2.6 Nylon Rope.....35
 2.7 Instrumentation.....37
 2.7.1 VMCM.....37
 2.7.2 Tension Cell.....42
 2.7.3 Engineering Instrument.....42
 2.7.4 Continuity Meter.....45
 2.7.5 Acoustic Release.....45
 2.8 Mooring Hardware.....46
3.0 The Fishbite Record.....47
 3.1 Derivation of Fishbite Data.....47

3.2	Evidence of Fishbite Activity on ESOM I.....	49
3.2.1	Fishbite Distribution.....	49
3.2.2	Results from Observations.....	50
3.3	Evidence of Fishbite Activity on ESOM II.....	52
3.3.1	Fishbite Distribution.....	52
3.3.2	Results from Observations.....	53
3.4	Significance of the Fishbite Record.....	57
3.4.1	The Fishbite Attack.....	57
3.4.2	Measurement of Fishbite Resistance.....	59
3.5	Fishbite Test Summary and Conclusions.....	60
4.0	Acoustic Telemetry.....	61
4.1	Background.....	61
4.2	Acoustic telemetry experiment.....	61
5.0	Conclusions.....	69
	References.....	72
	Appendix A: ESOM E/M Cable #20 Failure Report.....	75
	Appendix B: VMCM Test Report.....	78
	Appendix C: Engineering Instrument Specifications.....	82

LIST OF FIGURES

1	ESOM I Mooring.....	13-14
2	ESOM II Mooring.....	15-16
3	ESOM Buoy.....	21
4	E/M Cable Samples.....	27
5	In-House Epoxy Termination.....	28
6	Swage Socket Termination.....	29
7	Failed Swage Socket Termination.....	31
8 (A-B-C-D)	VMCM Data.....	38-41
9	Tension Cell Data.....	43
10	Engineering Instrument Data.....	44
11	Zytel Jacketed Steel Wire Rope.....	54
12	Kevlar Jacketed Line.....	55
13	Fishbite on Spectra Line.....	55
14	ESOM II electronic schematics.....	63
15	Cumulative results of acoustic modem lowering to 2700m.....	65
16	Data Record from acoustic modem at 1500m.....	67
17	Wind speed and error probability data record...	68

LIST OF TABLES

I	Mooring Component Samples.....	17
II	Mechanical Test Samples.....	23
III	Mechanical Test Results (ESOM I).....	23
IV	Mechanical Test Results (ESOM II).....	25
V	EM Cable Tensile Test.....	32
VI	Nylon Rope Tensile Test.....	36
VII	Fishbite Vs. Depth - ESOM I.....	49
VIII	Fishbite Vs. Depth - ESOM II.....	52
IX	Fishbite on Main Mooring Line Vs. Fishbite Test Samples.....	58

1.0 INTRODUCTION

The selection of materials, instruments, and techniques for the pursuit of oceanographic research conducted from moored arrays is based, to a large extent, on a systematic evaluation of candidate materials and prototype instrumentation. This evaluation spans from bench and lab tests, to a long term exposure of the better candidates to their projected service environment.

Following this progressive approach, the Ocean Systems and Moorings Laboratory (OS&ML) of the Woods Hole Oceanographic Institution (WHOI) has completed the design, the deployment, and the post-cruise analysis of an Engineering Surface Oceanographic Mooring (ESOM), specially conceived to permit the controlled evaluation of:

- new prototype buoy, made of SURLYN foam, with low roll and large buoyancy characteristics
- new wire ropes of different constructions
- new electromechanical cables and their terminations, for hard wire telemetry applications
- new protective armors for wire and synthetic ropes
- strut fairings in surface mooring applications.

In addition, the Advanced Engineering Laboratory (AEL) of WHOI, taking advantage of the mooring availability deployed and tested an acoustic telemetry system designed for applications requiring

communication between a number of remote modems distributed along the mooring line and a single master located at the buoy.

ESOM was set at $32^{\circ}08'.7$ N, $64^{\circ}43'.5$ W in March 1989 and was recovered in November 1990. After the first 12 months at sea (ESOM I), the mooring was turned around and samples were removed for analysis. The mooring was then reset (ESOM II) with the experimental acoustic link installed. The mooring remained on station for a total of 18 months, during which it survived many storms, including hurricane Dean which hit the ESOM site on August 6, 1989 with 110 knot winds. The mooring finally parted due to the failure of an electromechanical cable termination. Thanks to the proximity of the logistic support provided by the Bermuda Biological Station for Research (BBSR) which owns and operates the R/V WEATHERBIRD, the drifting buoy and later the rest of the mooring were entirely recovered.

The following describes the ESOM mooring, its components to be tested, the method of testing, and the results obtained. The extent of the fishbite attacks and the performance of the protective armors are reviewed. Reasons for the mooring failure and recommendations for future, improved cable terminations are given. Finally, the very encouraging results obtained with the vertical acoustic telemetry modem are reviewed.

2.0 TEST RESULTS

2.1 METHODOLOGY

The ESOM mooring was a classical single point, compound taut mooring (Figures 1 - 2). It supported in line or attached in parallel, groups of one and two year exposure samples [1], see Table I. These groups were systematically distributed from top to bottom. At the end of one year, the first group of samples was removed and replaced by new ones to increase the size of the statistical data [2]. This approach permitted the evaluation of the deterioration of the components as a function of time (one-year versus two years) and distance from the surface (decreasing dynamic and corrosion effects, various kinds of fishbite attacks, etc.).

Upon final retrieval, all samples were carefully examined and tested. Testing of wire ropes and electromechanical cables included:

- o tensile break tests performed on new and exposed samples of wire ropes and E/M cables to determine the loss of ultimate strength and holding power of their termination

- o electrical tests of new and exposed E/M cables to detect shorts, opens and changes in electrical resistance and insulation properties

ESOM First Deployment Station Log #889			
Item #	Description	Depth (m)	Item #
1	Surface Buoy		1
2	3m 3/4" Chain	3	2
3	10m 1/2" WR	13	3
4	Dummy VMCM	15	4
5	10m 7/16" WR	25	5
6	VMCM	27	6
7	10m 3/8" US Steel WR w/ 10m 3/16" WR w/ ZYTEL Jacket	37	7
8	10m 3/8" US Steel WR w/ 10m 3/16" WR w/ ZYTEL Jacket	47	8
9	Dummy VMCM	49	9
10	10m 3/8" MW TB w/ Tubular Plastic Samples	59	10
11	10m 3/8" MW TB w/ Tubular Plastic Samples	69	11
12	10m 3/8" MW Nilspin w/ 3/8" SPECTRA w/ SS Braid In Jacket	79	12
13	10m 3/8" MW Nilspin w/ 3/8" SPECTRA w/ SS Braid In Jacket	89	13
14	10m 3/8" Loos WR w/ 3/8" KEVLAR w/ KEVLAR Braided Jacket	99	14
15	10m 3/8" Loos WR w/ 3/8" KEVLAR w/ KEVLAR Braided Jacket	109	15
16	50m 3/8" MW TB WR w/ Endeco Strut Fairings	159	16
17	40m 7/16" 3x18 E/M Cable w/ Swage Terminations	199	17
18	40m 7/16" 3x18 E/M Cable w/ Swage Terminations	239	18
19	Stainless Steel STEM Continuity Meter	240	19
20	40m 7/16" 3x18 E/M Cable w/ Epoxy Terminations	280	20
21	40m 7/16" 3x18 E/M Cable w/ Epoxy Terminations	320	21
22	Dual Continuity Meter	321	22
23	40m 3/8" 3x19 E/M Cable w/ Epoxy Terminations	361	23
24	40m 3/8" 3x19 E/M Cable w/ Epoxy Terminations	401	24
25	80m 5/16" MW TB WR w/ 40m 3/16" WR w/ ZYTEL Jacket	481	25
26	20m 5/16" MW TB w/ Tubular Plastic Samples	501	26
27	40m 5/16" MW TB WR w/ 3/8" SPECTRA w/ SS Braided Jacket	541	27

FIGURE 1: ESOM I Mooring Schematics

ESOM (continued)			
Item #	Description	Depth (m)	Item #
28	40m 5/16" MW TB WR w/ 3/8" SPECTRA w/ SS Braid in Jacket	581	28
29	40m 5/16" MW TB WR w/ 3/8" KEVLAR w/ KEVLAR Braided Jacket	621	29
30	40m 5/16" MW TB WR w/ 3/8" KEVLAR w/ KEVLAR Braided Jacket	661	30
31	140m 5/16" MW TB WR	801	31
32	60m 5/16" MW TB WR w/ (2) 30m 5/16" WR w/ ZYTEL Jacket	861	32
33	20m 5/16" MW TB WR w/ Tubular Plastic Samples	881	33
34	30m 5/16" MW TB WR w/ SPECTRA w/ SS Braided Jacket	911	34
35	30m 5/16" MW TB WR w/ SPECTRA w/ SS Braided Jacket	941	35
36	30m 5/16" MW TB WR w/ 3/8" KEVLAR w/ KEVLAR Braided Jacket	971	36
37	30m 5/16" MW TB WR w/ 3/8" KEVLAR w/ KEVLAR Braided Jacket	1001	37
38	500m 5/16" WR	1501	38
39	300m 5/16" WR	1801	39
40	Engineering Instrument	1802	40
41	100m 5/16" WR	1902	41
42	Wrapped Termination	1903	42
43	500m 13/16" Nylon Rope	2403	43
44	(2) 17" GB on 2m 3/8" Trawler Chain	2405	44
45	420m 3/4" Nylon Rope	2825	45
46	(60) 17" GB in Super Ribbed Hard Hats on 3/8" Trawler Chain	2885	46
47	2m 1/2" Chain	2887	47
48	AMF Release	2889	48
49	5m 1/2" Chain	2894	49
50	20m 1" Nylon	2914	50
51	5m 1/2" Chain	2915	51
52	6000 lb Anchor		52

MW = MacWhyte WR = Wire Rope
TB = Torque Balanced GB = Glass Balls

FIGURE 1: ESOM I Mooring Schematics

ESOM Second Deployment - Station Log #903			
Item #	Description	Depth (m)	Item #
1	Surface Buoy		1
2	3m 3/4" Chain	3	2
3	10m 1/2" WR	13	3
4	Dummy VMCM	15	4
5	10m 7/16" WR	25	5
6	VMCM	27	6
7	10m 3/8" US Steel WR w/ 10m 3/16" WR w/ ZYTEL Jacket	37	7
8	Dummy VMCM	39	8
9	10m 3/8" McW TB WR w/ Tubular Plastic Samples	49	9
10	Dummy VMCM	51	10
11	10m 3/8" McW Nilspin WR w/ 3/8" SPECTRA w/ SS Braided Jacket	61	11
12	Dummy VMCM	63	12
13	10m 3/8" LOOS WR w/ 3/8" KEVLAR w/ KEVLAR Braided Jacket	73	13
14	50m 3/8" WR w/ Fairing	123	14
15	40m SAIC " Quiet Cable" WR	163	15
16	40m 3x18 7/16" E/M Cable w/ Swage Termination	203	16
17	Continuity Meter	204	17
18	40m 3x18 7/16" E/M Cable w/ Epoxy Terminations	244	18
19	Dual Continuity Meter	245	19
20	40m 3x19 3/8" E/M Cable w/ Epoxy Terminations	285	20
21	Acoustic Modem	286	21
22	100m 5/16" McW TB WR	386	22
23	80m 5/16" McW TB WR + (2) 40m WR w/ ZYTEL Jacket	466	23
24	20m 5/16" WR + Tubular Plastic	486	24
25	40m 5/16" McW TB WR + 3/8" SPECTRA	526	25
26	40m 5/16" McW TB WR + 3/8" KEVLAR	566	26

FIGURE 2: ESOM II mooring schematics

ESOM (continued)			
Item #	Description	Depth (m)	Item #
27	140m McW TB WR	706	27
28	100m 5/16" McW TB WR	806	28
29	60m 5/16" McW TB WR + 3/16" WR w/ ZYTEL Jacket	866	29
30	20m 5/16" McW TB WR + Tubular Plastic	886	30
31	30m 5/16" McW TB WR + 3/8" SPECTRA	916	31
32	30m 5/16" McW TB WR + 3/8" KEVLAR	946	32
33	30m 5/16" McW TB WR + SAIC "Quiet Cable"	976	33
34	30m 5/16" McW TB WR	1006	34
35	500m 5/16" McW TB WR	1506	35
36	Acoustic Modem	1507	36
37	300m 5/16" McW TB WR	1807	37
38	Engineering Instrument	1808	38
39	100m 5/16" McW TB WR	1908	39
40	500m 13/16" Nylon	2408	40
41	(2) GB on Dual Bracket	2409	41
42	420m 3/4" Nylon	2829	42
43	Acoustic Modem + GB	2830	43
44	(58) GB on Trawler Chain	2888	44
45	2m 1/2" Chain	2890	45
46	Acoustic Release AMF	2891	46
47	5m 1/2" Chain	2896	47
48	20m 1" Nylon	2916	48
49	5m 1/2" Chain	2921	49
50	6000lb Anchor (Wet Weight)		50

McW = MacWhyte
TB = Torque Balanced

FIGURE 2: ESOM II mooring schematics

TABLE I
MOORING COMPONENT SAMPLES

No.	Test	No. of Samples	Description	Total Length m.
1	Mechanical	1	1/2" MacWhyte torque balanced wire rope	10
2	Mechanical	1	7/16" MacWhyte torque balanced wire rope	10
3	Mechanical	2	3/8" U.S. Steel "Base"	20
4	Mechanical	2	3/8" MacWhyte torque balanced wire rope	20
5	Mechanical	2	3/8" MacWhyte Nilspin wire rope	20
6	Mechanical	2	3/8" Loos torque balanced wire rope	20
7	Fishbite	2	3/16" wire rope w/Zytel jacket	20
8	Fishbite	2	Tubular plastic armors 5/8" I.D.	20
9	Fishbite	2	3/8" Spectra w/stainless teel braid and Spectra jacket	20
10	Fishbite	2	3/8" Kevlar w/Kevlar braid jacket	20
11	Mechanical	2	Endeco PVC clip on fairings on 1/2" MacWhyte torque balanced wire rope	50
12	Electro Mechanical	2	3x18 7/16" MacWhyte EM cable w/swage socket terminations	80
13	Electro Mechanical	2	3x18 7/16" Consolidated EM cable with "in-house" epoxy terminations	80
14	Electro Mechanical	2	3/19 3/8" MacWhyte EM cable with "in-house" epoxy terminations	80
15	Fishbite	1	3/16" wire rope w/Zytel jacket	80
16	Fishbite	7	1/2" wire rope w/tubular plastic armors	20
17	Fishbite	2	3/8" Spectra w/stainless steel braid w/Spectra jacket	80
18	Fishbite	2	3/8" Kevlar w/Kevlar braid jacket	80
19	Fishbite	1	3/16" wire rope w/Zytel jacket	60
20	Fishbite	7	1/2" wire rope w/tubular plastic samples	20
21	Fishbite	2	3/8" Spectra w/stainless steel braid w/Spectra jacket	60
22	Fishbite	2	3/8" Kevlar w/Kevalr braid jacket	60

o visual inspection, especially if significant changes in the above-mentioned properties have occurred. To this end, new and damaged samples were prepared (removal of jacket, exposure of conductors, opening of terminations, etc.) and visually inspected with microscopic magnification, as required. Emphasis was placed on determining the extent of corrosion damage, signs of abrasion, fretting, mechanical distortion (kinks, bird caging), yielding and fracture faces typical of fatigue and/or bending.

All other mooring components were examined and tested to evaluate their performance. Some of them were found to be in excellent condition and were left in storage at the BBSR [3]. These components can be used for future mooring deployments in the Bermuda area.

2.2 SURFACE BUOY

The ESOM surface buoy was the first operational use of SURLYN foam at WHOI. Although samples had been extensively tested, no records existed for a long-term oceanic exposure [4]. After the 18 month deployment the buoy was recovered in choppy seas without causing any damage to its hull or to the tower structure. The foam material acted as a bumper, absorbing the impact energy during the deck landing. Considering its shape and size, the buoy is very manageable and can be handled safely (Figure 3). A modified folding tower would augment the clearance through the stern A-frame when lifting the buoy [5].

A preliminary inspection showed no signs of material degradation due to environmental agents. No discoloration due to UV action was noticed on the SURLYN foam. No cracks, abrasion or punctures were found on the hardened skin of the foam body. Light biofouling (algae) and some goose barnacles were growing on the immersed section of the hull, which had been coated with antifouling paint. The nylon straps (stitching and hardware) appeared to be in good condition. Overall, the buoy retained its hemispherical shape with no evidence of permanent deformation or bumps.

The aluminum (6061-T6) structure, including the instrument well, deck, tower and point of attachment, was inspected and found to be in

good condition. The buoy keel, also made of aluminum (5086-H34) was covered with biofouling, but when cleaned, no evidence was found of corrosion or welding cracks. The tension cell was removed from it, and the hardware, including the electrical harness, appeared to be intact. The instrument well was found completely dry with no sign of water infiltration or moisture accumulation. The electronics and batteries were removed from the well; the meteorological sensors, antennae and electrical harness were stripped off the tower. All these components were then shipped to WHOI on the R/V Oceanus.

In the future the sea-keeping performance of the new surface buoy will be closely scrutinized. An accelerometer package will be mounted to monitor and record the buoy dynamic response to waves and wind. This information will add to the model test data collected at the wave research facility of the Oregon State University in corroborating the sea-keeping properties of the hemispherical, low ballast buoy [6].

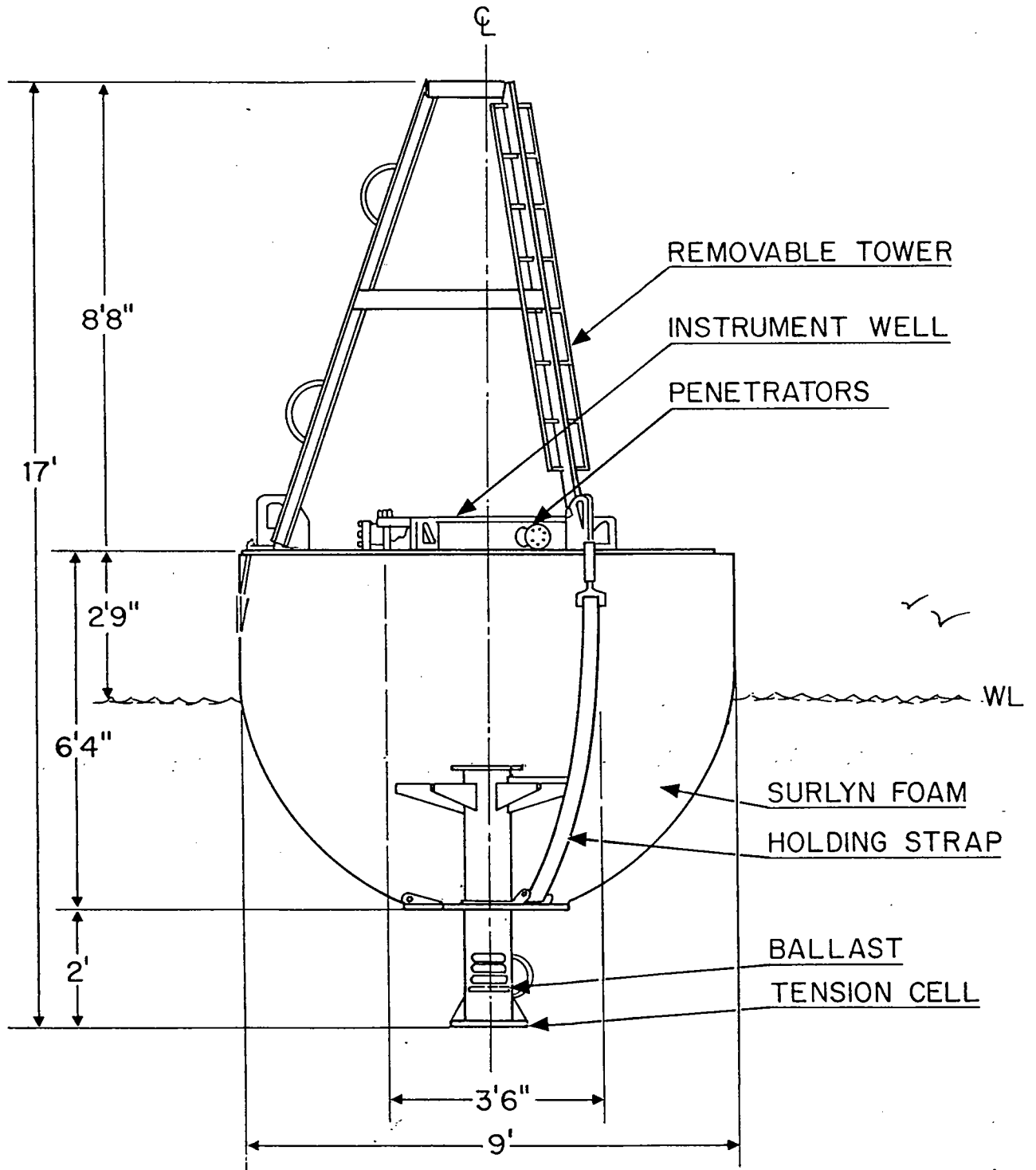

9' WHOI HEMISPHERICAL BUOY

FIGURE 3: ESOM buoy

2.3 WIRE ROPE

The torque balanced 3x19 wire rope is the standard for surface oceanographic mooring applications. Previously manufactured by the U.S. Steel Corp., it is now produced by several manufacturers, such as Loos and MacWhyte. The mechanical characteristics (strength, rotation, etc.) of these new ropes have been evaluated through shore laboratory tests and shallow water tests [7]. The ESOM experiment provided the needed platform for a long-term deep water exposure.

Six samples of 3x19 wire rope were deployed. All were made of galvanized improved plow steel (GIPS) and exhibited different degrees of torque balancing and stress relief (Table II). All samples were jacketed and terminated by a swaged socket. Each termination was protected by a stress relief polyurethane boot. During the first turnaround cruise, these samples were retrieved and inspected to assess their integrity. Four mechanical test samples, which had been deployed as two separate segments, were brought ashore and pull tested to failure to assess their residual strength after one-year deployment (Table III). The remaining sections of each sample were redeployed for the long-term evaluation. Upon final retrieval after 18 months at sea all wire rope samples were examined for mechanical and fishbite damage. All of them appeared in good condition, except for some jacket abrasions and cuts due to deck handling and fishbites. Biofouling was observed on wire rope jackets down to a depth of 100m.

TABLE II
MECHANICAL TEST SAMPLE

No.	Description	Weight In Air lbs/ft	Min. Nom. Breaking Load (lbs)	0.2% Yield Strength (lbs)
1	1/2" MacWhyte torque balanced wire rope	.392	25,700	22,600
2	7/16" MacWhyte torque balanced wire rope	.304	20,000	17,600
3	3/8" U.S Steel "base"	.220	14,800	13,000
4	3/8" MacWhyte torque balanced wire rope	.220	14,800	13,000
5	3/8" MacWhyte Nilspin wire rope	.273	14,400	10,000
6	3/8" Loos torque balanced wire rope	.300	13,900	11,120

TABLE III
ESOM I: MECHANICAL TEST RESULTS

Item No.	Description	Total Months Exposed	Strength (lbs)		
			New Nom.	Minimum Breaking Load Used	
				First Sample	Second Sample
8	3/8" U.S. Steel Wr. Tb.	12	14,800	15,250	15,250
10	3/8" Wr. Tb. MacWhyte	12	14,800	16,250	16,250
13	3/8" Wr. McWhyte Nilspin	12	14,400	13,900	14,250
15	3/8" Wr. Tb. Loos	12	13,900	14,300	14,600
28	5/16" Wr. Tb. MacWhyte	12	10,300	10,750	11,150
29	5/16" Wr. Tb. MacWhyte	12	10,300	10,550	10,100
34	5/16" Wr. Tb. MacWhyte	12	10,300	10,500	10,300
36	5/16" Wr. Tb. MacWhyte	12	10,300	9,750	9,750

Wire rope sections extending three feet from each termination were cut off to be tested in the tensile machine. Prior to testing, the jacket and termination boot were removed from each sample to inspect the bare wire rope and the swaged fitting for corrosion. No evidence of corrosion was found. Unterminated ends were then swaged with a new socket. All samples tested retained or exceeded the original rated breaking strength after the 12 and/or 18 month deployment thus showing no signs of strength deterioration due to fatigue or corrosion (Table IV).

TABLE IV
ESOM II: MECHANICAL TEST RESULTS

Item No.	Description	Total Months Exposed	Strength (lbs) Minimum Breaking Load		
			New Nom.	Used	
				First Sample	Second Sample
3	1/2" Wr. Tb. MacWhyte	18	25,700	16,200	18,300*
5	7/16" Wr. Tb. MacWhyte	18	20,000	22,500	21,750
7	3/8" Wr. Tb. U.S. Steel	18	14,800	15,500	15,400
9	3/8" Wr. Tb. MacWhyte	18	14,800	16,400	16,400
11	3/8" Wr. MacWhyte Nilspin	18	14,400	13,500	16,700
13	3/8" Wr. Tb. Loos	18	13,900	15,400	14,700

14	3/8" Wr. Tb. MacWhyte (with fairings)	6	14,800	16,200	16,200
15	3/8" SAIC Quiet Cable Wr.	6	14,800	15,350	15,600
22	5/16" Wr. Tb. MacWhyte	6	10,300	11,500	11,750
23	5/16" Wr. Tb. MacWhyte	18	10,300	10,500	10,450
24	5/16" Wr. Tb. MacWhyte	18	10,300	11,250	11,100
25	5/16" Wr. Tb. MacWhyte	18	10,300	10,500	10,250
26	5/16" Wr. Tb. MacWhyte	18	10,300	9,900	10,000
27	5/16" Wr. Tb. MacWhyte	6	10,300	11,750	10,600
28	5/16" Wr. Tb. MacWhyte	6	10,300	10,800	10,800
29	5/16" Wr. Tb. MacWhyte	18	10,300	10,750	10,650
30	5/16" Wr. Tb. MacWhyte	18	10,300	11,300	11,250
31	5/16" Wr. Tb. MacWhyte	18	10,300	9,750	10,200
32	5/16" Wr. Tb. MacWhyte	18	10,300	10,750	9,700
33	5/16" Wr. Tb. MacWhyte	6	10,300	11,950	11,850
34	5/16" Wr. Tb. MacWhyte	6	10,300	11,950	11,900
35	5/16" Wr. Tb. MacWhyte	18	10,300	10,800	11,000
37	5/16" Wr. Tb. MacWhyte	18	10,300	10,900	11,000
39	5/16" Wr. Tb. MacWhyte	18	10,300	11,450	11,800

* New swage fitting was not properly machined.

2.4 ELECTROMECHANICAL (EM) CABLE

Two types of novel EM cables, using the proven 3x19 oceanographic rope construction were systematically tested (Figure 4). In the first type (MacWhyte Mfr.), the conductors are placed in the center of each strand. In the second type (Consolidated, Mfr.) the conductors are placed in the valleys between the strands [8]. Two self recording continuity meters periodically checked the EM cable electrical continuity.

Two types of EM cable terminations, both designed and built at WHOI, were tested during the ESOM experiment. The "in house" epoxy termination (Fig. 5) for 3x19 EM cables had been previously during the six month STEM experiment with excellent results [9]. The new swage socket termination for the 3x18 EM cables (Fig. 6) was deployed at sea for the first time.

During the turnaround cruise, all the EM samples were recovered, inspected and electrically tested. Data from the two continuity meters did not indicate any kind of electrical failure. The EM cable "long term" samples appeared to be in good condition, with no structural damage except for a few superficial cuts due to fishbites. The jacket damage was repaired and the three samples were redeployed for the ESOM II experiment. The "short term" samples were further tested at the BBSR and at WHOI. Item 18 (Figure 1) had a failed pigtail in the swage termination. The cable itself tested properly (continuity and leakage resistance tests).

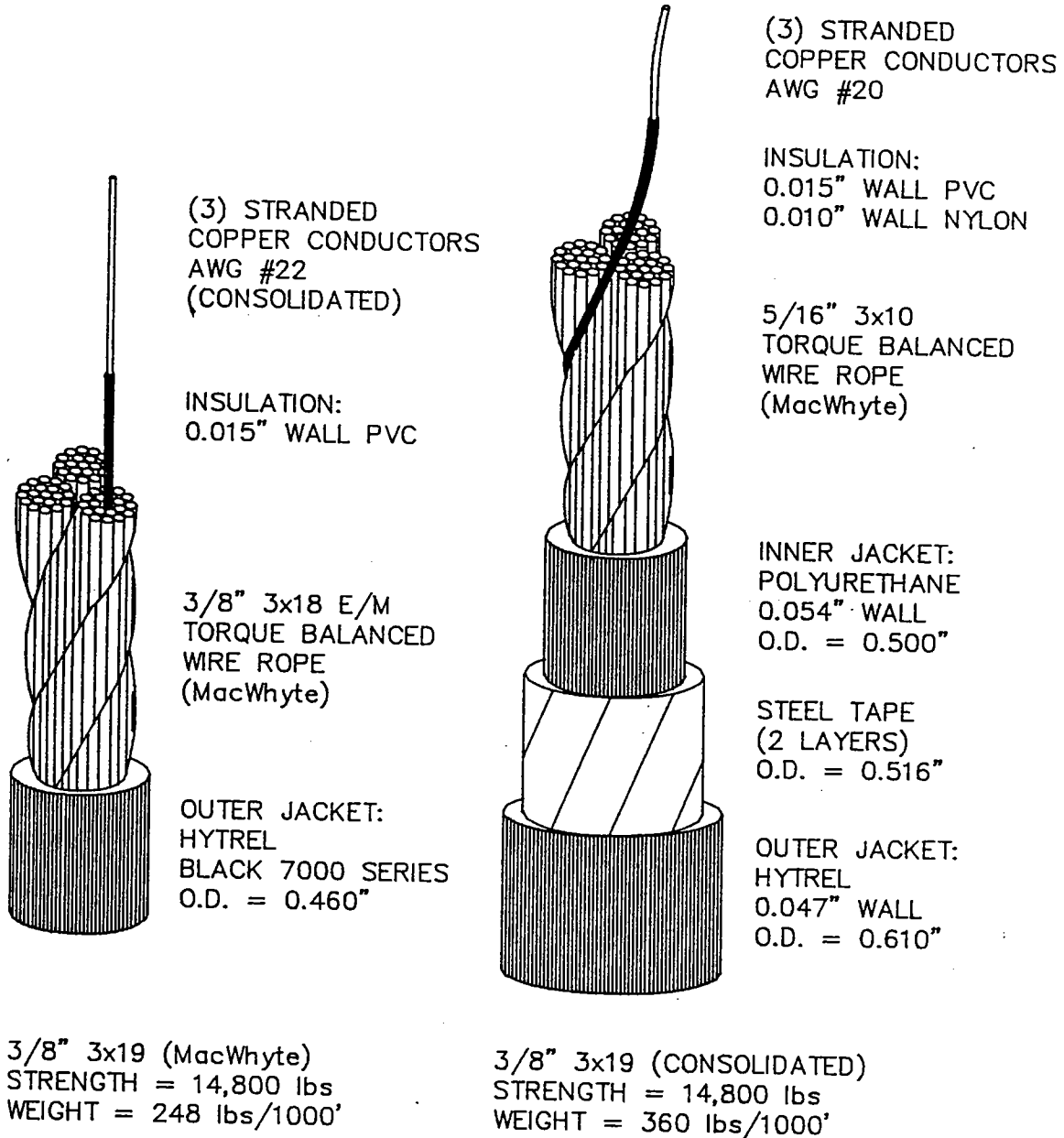

FIGURE 4: E/M cable samples

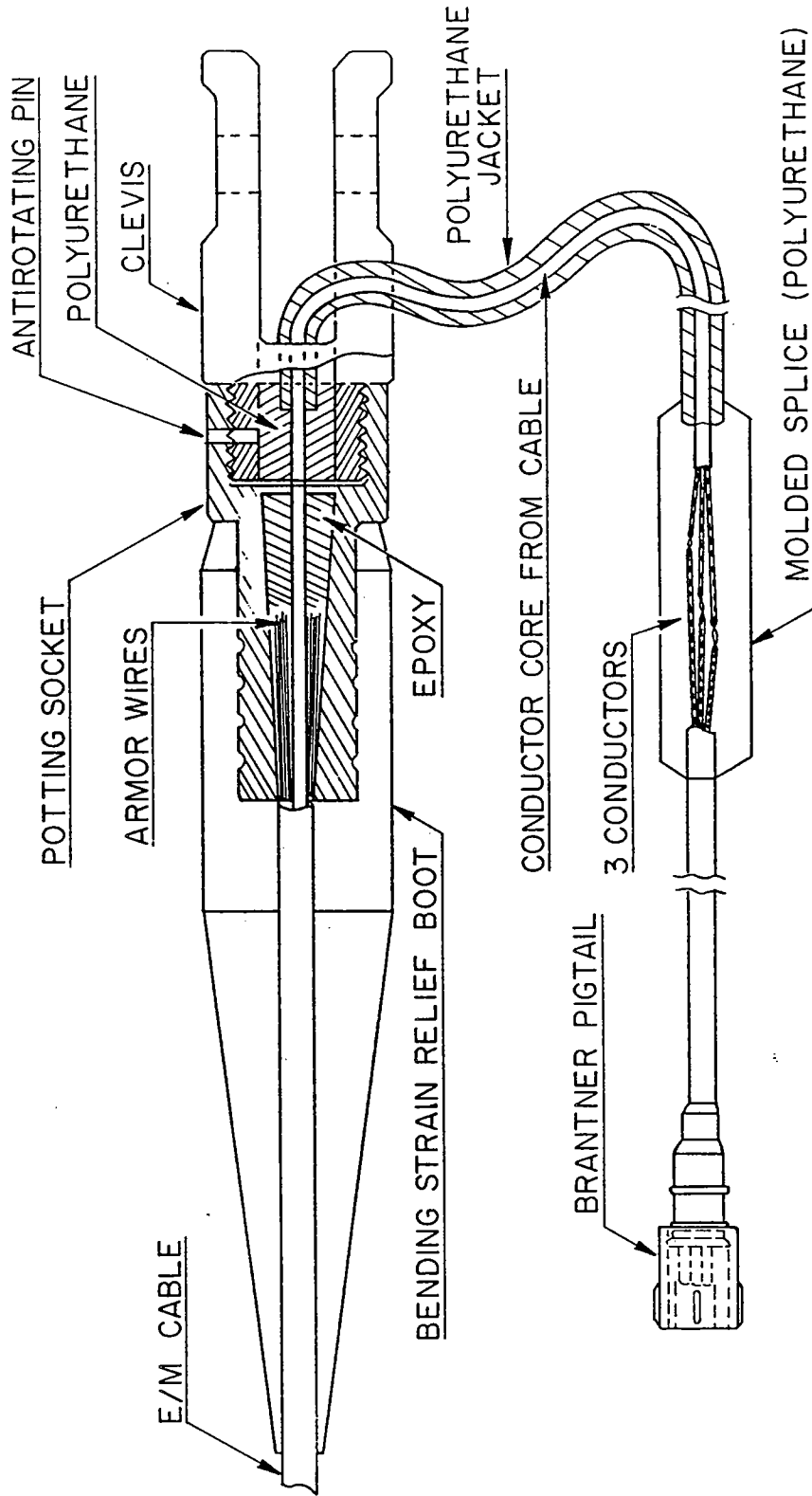

FIGURE 5: In-house epoxy termination

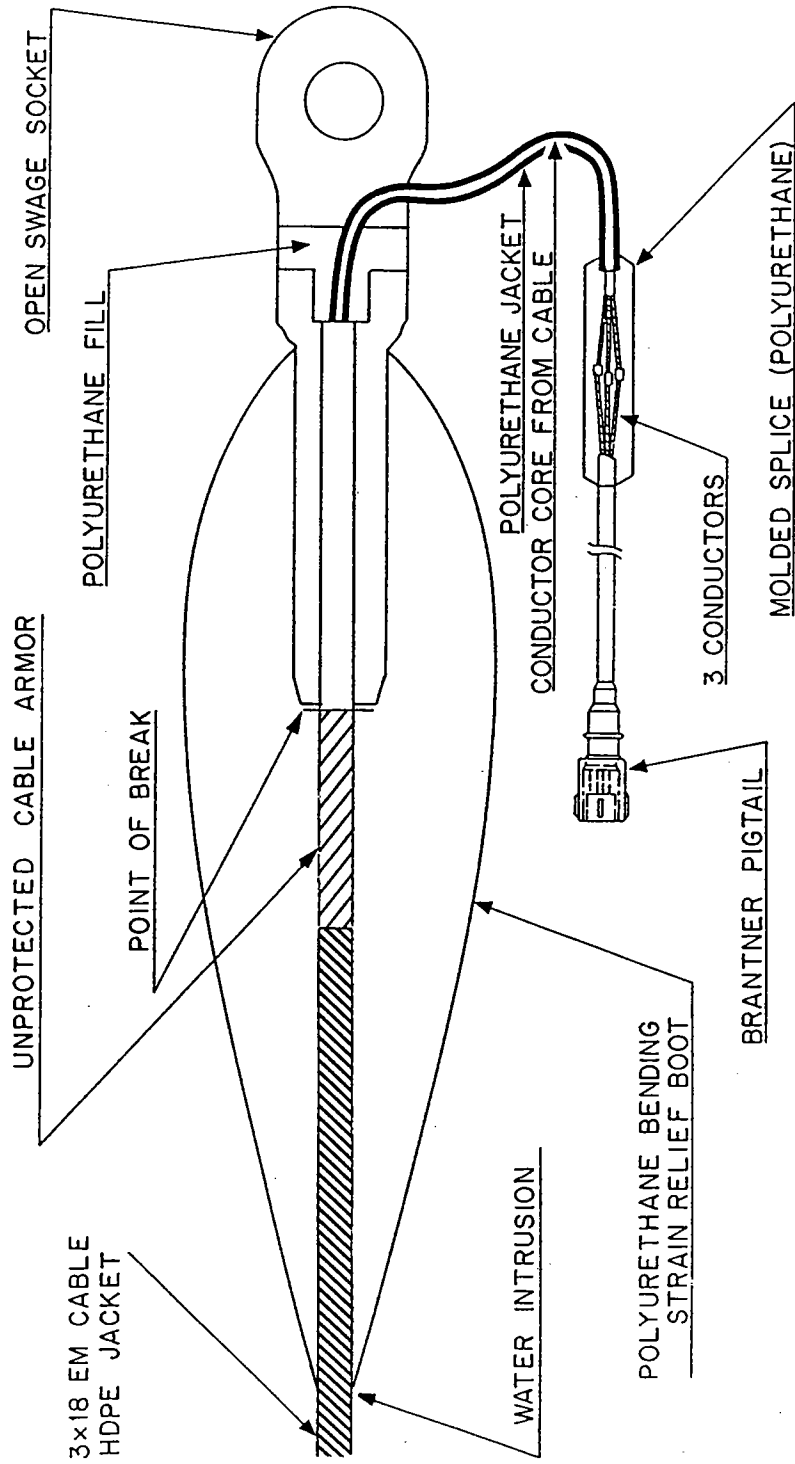

FIGURE 6: Swage socket termination

The two samples (Items 18, 23, Fig.1) were subsequently tested at WHOI for residual mechanical strength (Table V).

Six months after redeployment, the ESOM II mooring failed due to a mechanical break of the 3x18-7/16" EM cable section (Item 16, Fig.2) This section was carefully examined at WHOI and then sent to Al Lucht, Wire Rope Industry Consultant for microscopic examination and analysis [10]. His conclusions on the modes and causes of cable failure were:

- the cable did break at the end of the swaged fitting shank (Fig.6-7)
- the mode of cable failure was corrosion fatigue
- swaging resulted in initial indentation, or cracks at the surface of the armor wires; the termination mechanical design permitted the wires to flex and twist thus creating the mechanism for crack propagation
- deterioration due to fatigue was accelerated by corrosion resulting from 1) infiltration of sea water over the bare, unjacketed wires inside the boot, and 2) electro-chemical corrosion resulting from rupture in the insulation of the hot electrical wires in a salt environment; the insulation may have been damaged by swaging or by handling during the recovery and redeployment.

The report recommended that future terminations include the following changes:

- Avoid swaging, instead use epoxy filled socket
- Prevent flexing by using stronger, harder stress relief boot
- Provide watertightness and isolate the armor wires from sea water.

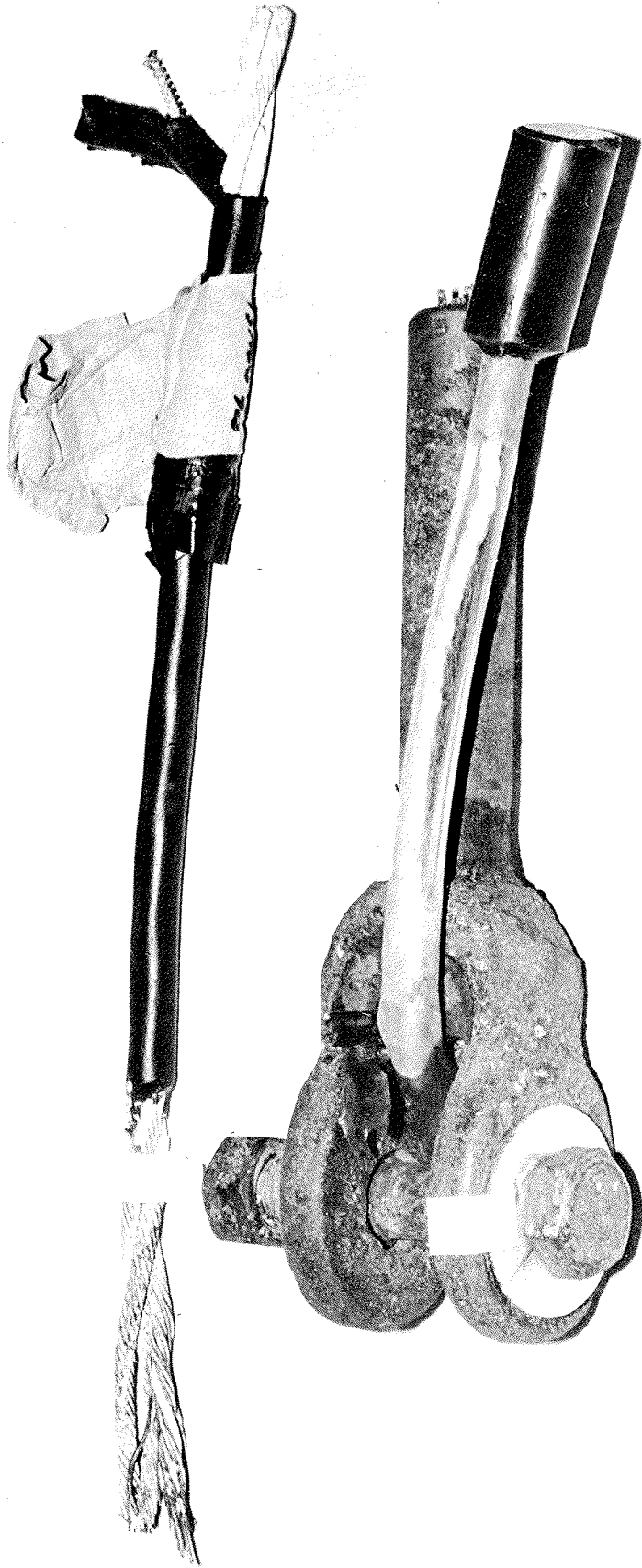

FIGURE 7: Failed swage socket termination

TABLE V

ESOM II: ELECTROMECHANICAL CABLE - TENSILE TEST

Item No.	Description	Total Months Exposed	Strength (lbs) Minimum Breaking Load		
			New Nom.	Used	
			First Sample	Second Sample	
ESOM I:					
18	3x18 7/16" (WR by MacWhyte) Swaged Termination	12	20,000	18,450	
23	3x19 3/8" (WR by Consolidate) In House Epoxy Termination	12	16,800	15,750	

ESOM II:					
16	3x18 7/16" (WR by (MacWhyte) Swaged Termination	18	20,000	19,250	19,600
18	3x18 7/16" (WR by MacWhyte) In house epoxy termination	18	20,000	17,850	19,200
20	3x19 3/8" (WR by Consolidated) In house epoxy termination.	18	16,800	19,400	19,200

The EM samples from ESOM II were tested at WHOI to detect shorts, open circuits and changes in leakage resistance. The failed sample (Item 16, Fig. 2), apart from the faulty termination, retained its mechanical and electrical characteristics. A second 3x18-7/16" EM cable (Item 18, Fig. 2) was found to be in excellent condition, and data from the continuity meter confirmed its proper functioning throughout the second deployment. The 3x19-3/8" EM cable sample (Item 20, Fig. 2) did not pass the electrical test. An open circuit was found in the upper pigtail section of the termination. Data from the continuity meter showed that the electrical failure occurred a few hours after the second deployment. A detailed report on this sample is presented in Appendix A.

All EM samples were pull tested following the same procedure used for the mechanical test samples (Table V). Final results from the "long term" exposure test indicate that all cable samples retained their mechanical and electrical integrity.

2.5 FAIRINGS

A new low cost, rigid strut fairing for 3/8" jacketed wire rope was jointly designed and developed by the OS&ML and Endeco Inc. for the ESOM test. In this experiment, the fairing had a dual function of reducing the drag on the mooring line and protecting it from fishbite attacks. The fairings were placed over a section of 3/8" jacketed, torque balanced wire rope. This section was located at a depth of 123m from the surface, where both high current and fishbites were expected.

The clip-on fairings are made of black PVC, and they have a drag coefficient, C_D , equal to 0.4. Each fairing is 0.91m long and is fitted over the wire rope during deployment. Several fairings were placed over a 50m long wire section. A stacking ring was placed every 10m in order to prevent the fairings from bunching and binding together. The fairings were recovered after 18 months. The top ones were covered by light biofouling, and two of them were shattered and split in half, probably due to mooring motion. All the other fairings were in good condition. The wire rope jacket, underneath the fairings, was superficially damaged by the fairing friction. Fishbite test results can be found in section 3.3.2 of this report.

2.6 NYLON ROPE

The lower part of the ESOM I and ESOM II moorings consisted of approximately 1,000m of nylon rope. Two continuous lengths of eight-strand Columbian plaited nylon rope made up this section; the upper rope length with diameter of 13/16" was deployed for the complete duration of the experiment. The lower length with diameter of 3/4" was replaced during the turnaround cruise, since it had been damaged by an adjacent glass ball hard hat.

During the final recovery, some damage was done to the nylon rope terminations and the first 20m of each section. This was due to the rough weather conditions, causing the rope to chafe on deck under severe tension. The remainder of the rope was recovered in excellent condition and wound on the ship's main winch drum. During unspooling on a wooden reel, the rope was inspected for fishbite and mechanical damage. Except for the sections contiguous to the terminations, both lengths of nylon rope were found to be in good condition with no evidence of fishbiting. Two nylon rope samples were brought back to WHOI for pull testing at the tensile machine whereas the bulk of the rope was left at the BBSR for future use. Results from this test, shown in Table VI, indicate that more tests would be required, with samples taken away from the terminations, to fully assess the remaining strength of the rope.

TABLE VI

ESOM II: NYLON ROPE - TENSILE TEST

Item No.	Description	Total Months Exposed	Strength (lbs)	
			New Nom.	Minimum Breaking Load
*40	13/16" Columbian nylon rope	18	17,000	9,700
42	3/4" Columbian nylon rope	6	14,200	11,200

*The Item No. 40 test sample was severely chafed.

2.7 INSTRUMENTATION

2.7.1 VECTOR MEASURING CURRENT METER (VMCM)

One recording VMCM was placed on each ESOM deployment at a depth of 27m. A sample of the data collected during the experiment is shown in Figure 8 (A-B-C-D). Two dummy VMCMs (no electronics) were deployed on ESOM I and four on ESOM II as an endurance test run by the Physical Oceanography Buoy Group at WHOI. The purpose of the test was to evaluate rotor bearings. A total of seven different bearings were tested and the results are presented in Appendix B. On ESOM II the current meter cages were coated with blue Ameron TBT bottom antifouling paint. Algal growth was severely reduced but the paint did not adhere well to the VMCM frames. In fact, once the instruments were recovered and dried, the paint peeled off in large flakes. Two rotor blades were found damaged on ESOM I on two different instruments; one rotor blade was found broken on ESOM II.

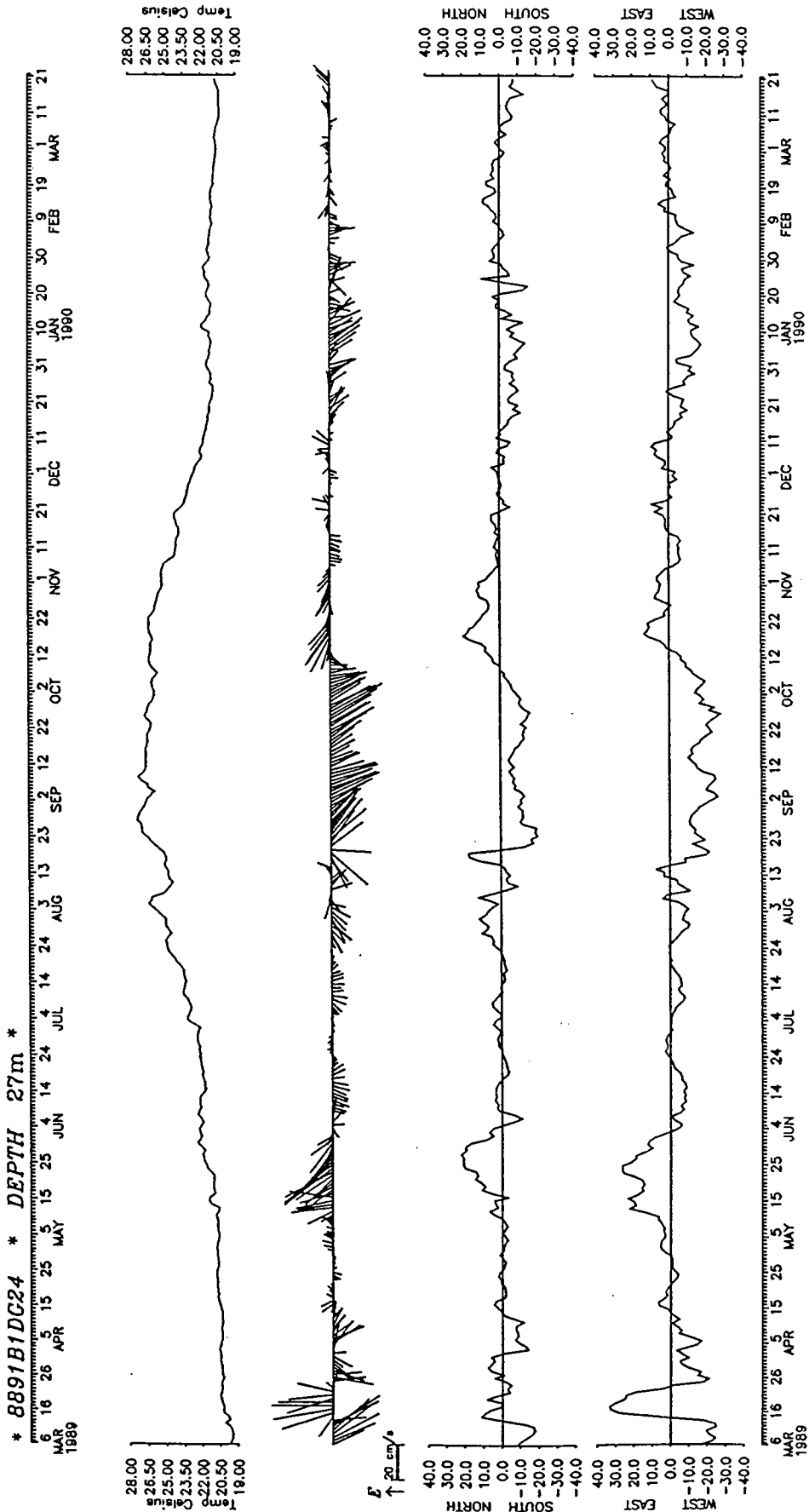

FIGURE 8b: VMCM data

* 9031C1DG24 * DEPTH 27m *

28 APR 1990 8 18 28 JUN 7 17 27 JUL 7 17 27 AUG 6 16 26 SEP 5 15 25 OCT 5 15 25 NOV 4

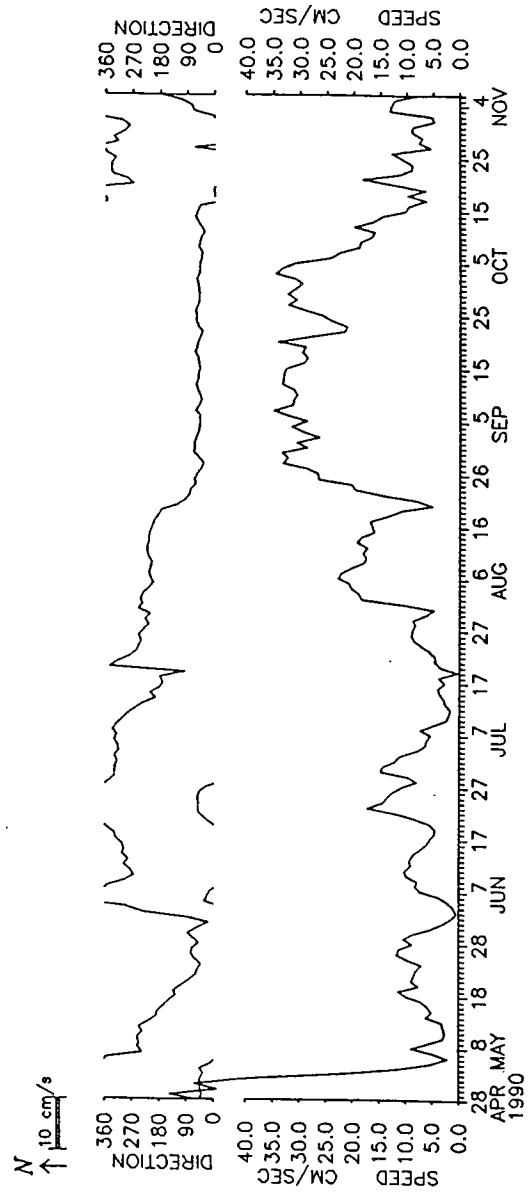
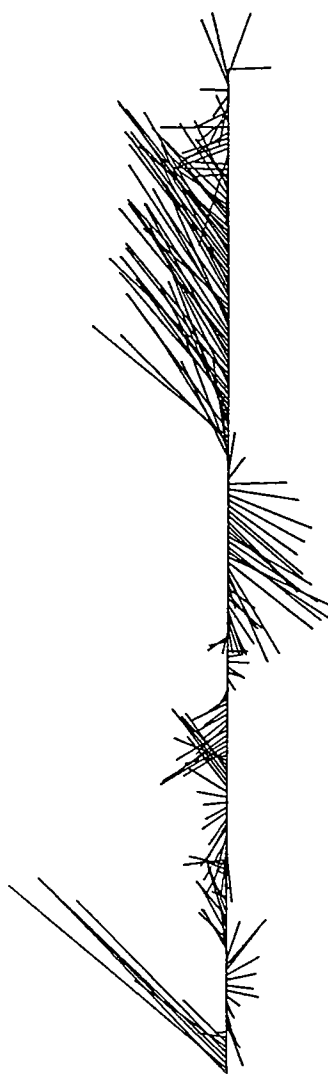
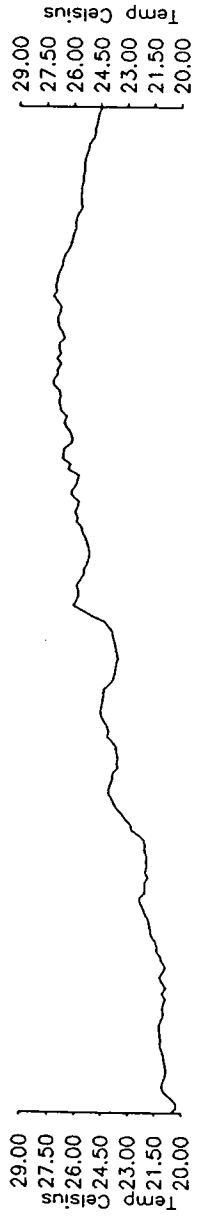
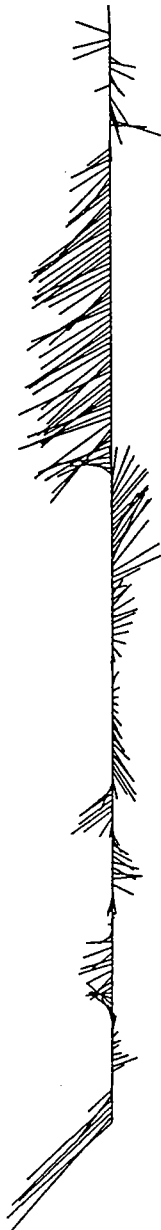
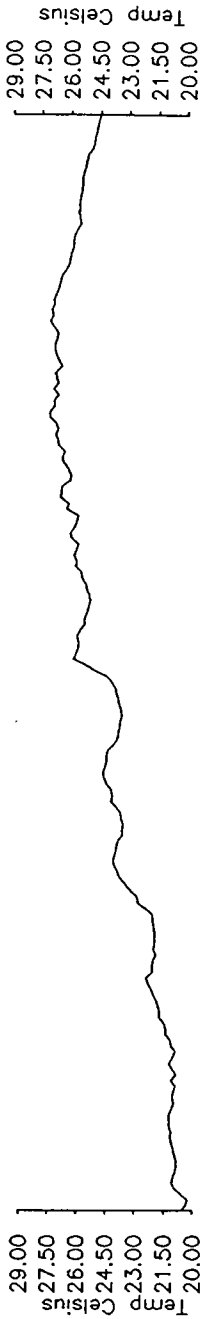

FIGURE 8c: VMCM data

* 9031C1DG24 * DEPTH 27m *



E
↑ 20 cm/s

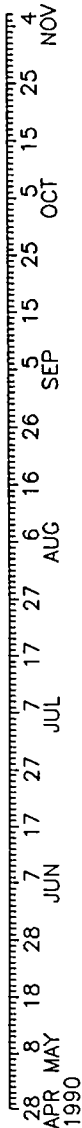
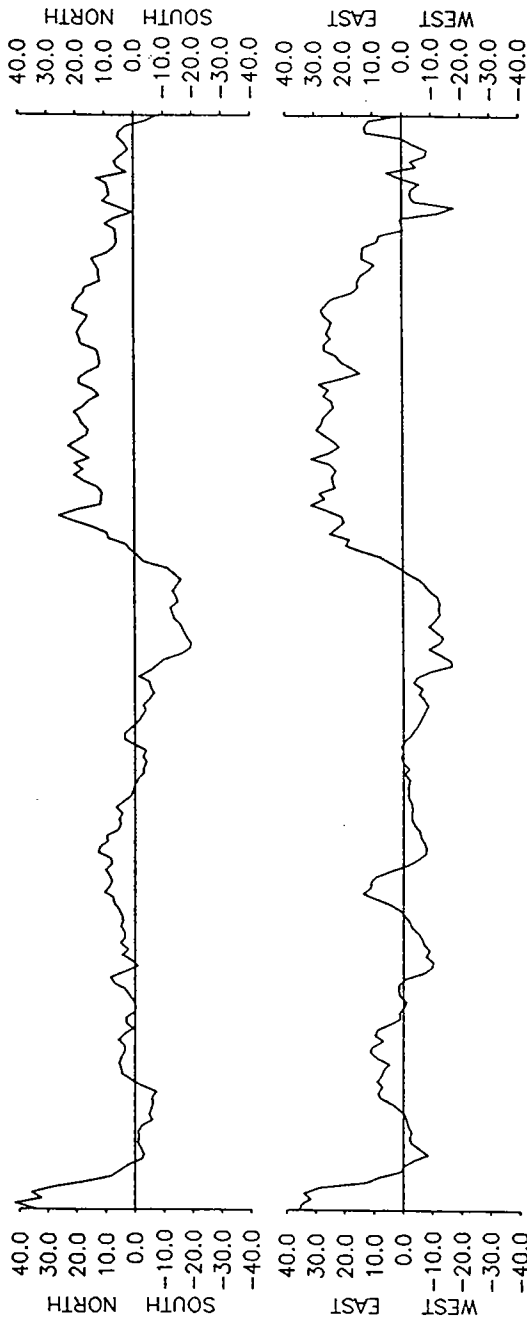

FIGURE 8d: VMCM data

2.7.2 TENSION CELL

A Teledyne Model 12367-20K tension cell, with a maximum capacity of 20,000 lbs, was mounted at the bottom of the surface buoy and connected through a shackle to the mooring. This sensor was carefully calibrated at WHOI prior to the deployment. Surface buoy tension data was transmitted daily to WHOI through ARGOS, to monitor buoy performance (Figure 9). When the surface buoy went adrift, the tension data clearly indicated a failure on the mooring line.

The sensor was recovered in good condition after the 18 month deployment. The underwater bulkhead connector and the pigtail going to the buoy instrument well were covered by heavy biofouling, but were otherwise undamaged.

2.7.3 ENGINEERING INSTRUMENT

A different engineering instrument was deployed on each of the ESOM mooring at a depth of 1,800m to monitor the performance of the mooring. This instrument, designed and built by the OS&ML at WHOI, collected data on temperature, tilt, tension and depth, taking samples of each parameter every 20 minutes. A complete data record for the 18 month deployment is available and stored on floppy disks. A sample of the tension data from ESOM II is plotted on Figure 10. Mechanical and electrical specifications for this instrument are given in Appendix C.

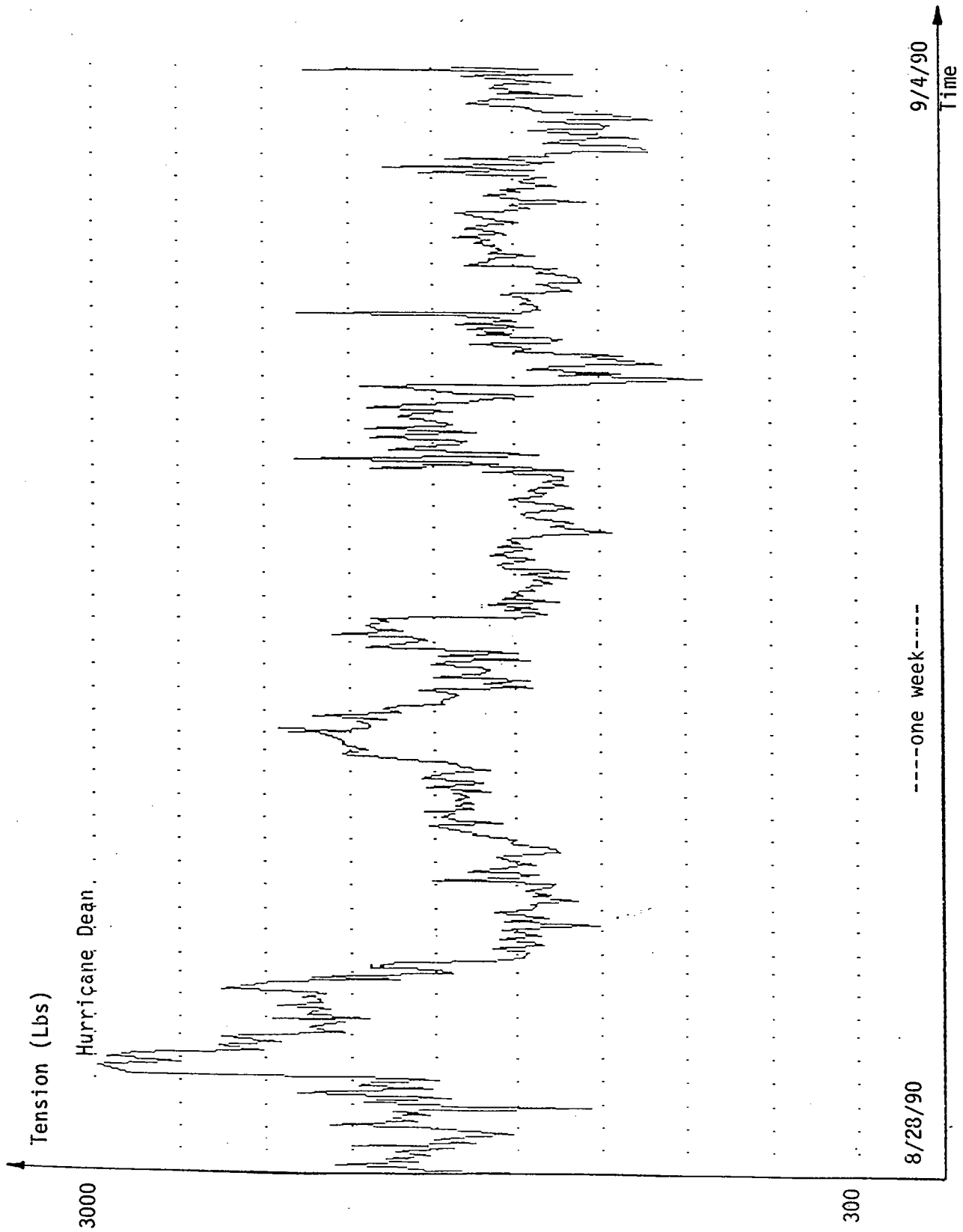

FIGURE 9: Tension cell data

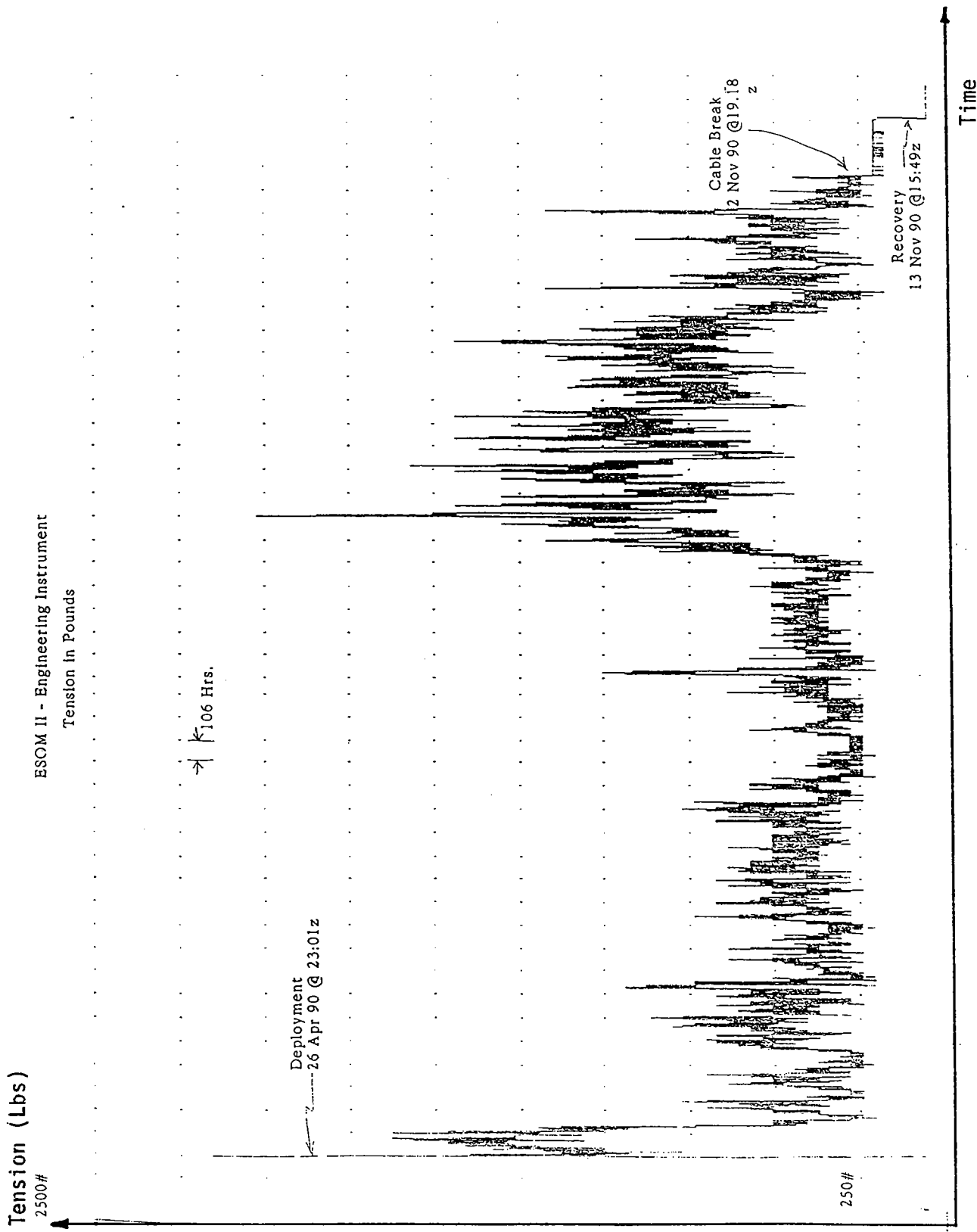

FIGURE 10: Engineering instrument data

2.7.4 CONTINUITY METER

Both single and dual continuity meters were deployed on each mooring to monitor the EM cable and test for open, shorts and electrical leakage. These instruments were developed and built by the OS&ML during the Buoy Farm shallow water tests for EM cables and terminations (1988-89). The continuity meter periodically checks the EM cable assembly for continuity through the three conductors and leakage to the instrument case (through the seawater). The dual continuity meter is a new version of the original instrument which stores data on a Tattletale computer, while the single meter uses an analog recorder.

During the ESOM II experiment, an early failure of Item 20 (3x19 - 3/8" EM cable) due to a termination pigtail malfunction was detected and recorded by the continuity meter.

2.7.5 ACOUSTIC RELEASE

An AMF acoustic release Model 322 was set on each mooring at a depth of 2,890m. It functioned properly releasing the array on both occasions at the first try. No sign of corrosion were found on this instrument at the end of the deployment.

2.8 MOORING HARDWARE

All mooring hardware, including shackles, pear links and chain, was replaced during the turnaround cruise. Some glass balls and hardhats were also replaced, where needed. Upon final recovery, all the hardware was examined for corrosion and failures. Chain sections were examined, measured and compared with new samples. The only significant sign of corrosion and wear was found on the lower part of Item 2 (3m 3/4" chain). The average measured diameter of the chain link was .005" less than on a new chain. This section was heavily rusted and covered with biofouling (algae) and goose barnacles.

The back-up flotation assembly was found to be in fair condition. During mooring recovery one glass ball broke free; about 15 plastic hard hats were found damaged. Since the age of the hard hats was unknown, it was impossible to estimate how much wear and tear they experienced during the ESOM deployment. The trawler chain on which the glass balls were mounted was found corroded and superficially pitted in some sections. It had been on-station for a total of 18 months. A one-meter-long sample from this chain was tested at the tensile machine and failed at 25,750 lbs. versus 45,000 lbs. for a new chain sample, a considerable loss in strength.

3.0 THE FISHBITE RECORD

3.1 DERIVATION OF FISHBITE DATA

The fishbite data acquisition procedure was the same for the ESOM I and the ESOM II deployments. Samples of fishbite protected ropes were attached in parallel to the main mooring line and distributed at various depths. This parallel arrangement ensures that the failure of a test sample does not result in the failure of the entire mooring. In addition, the entire main mooring line, from buoy to acoustic release, was treated as a continuous sample, itself exposed to possible attacks.

Fishbite protection can be assessed by the resistance to cutting of the different jacket materials, and the associated absence of strength degradation as determined by pull tests of retrieved specimens. Ideally one would hope to observe the presence of clearly identifiable teeth marks in the "soft" HDPE jacket of the main mooring line and the absence of similar marks or damage on protected samples attached at the same depths.

Three methods of fishbite protection were evaluated:

1. Tubular samples of hard, cut resistant plastics which could be used in some form to protect, in the future, wire or synthetic fiber ropes. This is essentially a material assessment test.

2. Jacket of hard plastics, such as ZYTEL, which can be extruded over wire ropes, and which offers greater protection than the commonly used HDPE jackets.

3. Special jackets braided over small synthetic fiber ropes. Two types have been procured and exposed:

Type 1: 1 x 18 KEVLAR rope. This rope has a central DACRON core, with six left hand inner strands and 12 additional right hand outer strands made of KEVLAR 29. Strand sizes and lay angles are selected to insure torque balance between the inner and the outer layers. The rope diameter is 1/4 inch, and its nominal strength is 10,000 lbs. The protective jacket is made of KEVLAR 29 yarns very tightly braided to an outside diameter of 3/8 inch. The jacket is almost "impossible" to cut when under tension.

Type 2: 1 x 18 SPECTRA rope. This rope is of the same construction as type 1 above. Material used is SPECTRA 900. The nominal strength is 9,000 Lbs. The protective jacket is made of stainless steel wires covered by SPECTRA fibers and tightly braided over the rope to an outside diameter of 3/8 inch. This jacket too is very difficult to cut.

All samples of ESOM I and II were recovered and carefully inspected for fishbite either on board the recovery vessel, or at the BBSR, or when back in Woods Hole. Method of inspection included macro and microscopic examination, as described in Reference 11.

3.2 EVIDENCE OF FISHBITE ACTIVITY ON ESOM I

Results obtained from the ESOM I experiment have already been published (Berteaux et al, 1990, Reference 2). A summary of these results is hereby included.

3.2.1 FISHBITE DISTRIBUTION: the fishbites at various ranges of submergence observed during ESOM I are tabulated in Table VII.

Table VII

ESOM I: FISHBITE VS. DEPTH

<u>Depth - Meters</u>	<u>Number of Bites</u>	<u>% of Total Bites</u>	<u>Bites/100m.</u>
0 - 9	0	0	0
10 - 49	5	4	10
50 - 199	6	5	4
200 - 499	40	33	13
500 - 999	66	55	13
1000 - 1999	3	3	0.3
TOTAL	120		

The majority (88%) of bites, were found between 200 and 1,000m deep. If intensity of biting, i.e., bites/100m. of line is calculated, the figures found in the last column of table VII are obtained. The occurrence of large numbers of bites off Bermuda at similar depths has been observed previously (Turner and Prindle, 1968).

3.2.2 RESULTS FROM OBSERVATIONS

Tubular specimens: tubes of hard plastic were used for obtaining preliminary fishbite resistance data on a variety of candidate materials with suitable mechanical characteristics and readily available on the open market. The retrieved specimens did show a variety of mechanical damages related mostly to overboard handling. Few bites could be clearly identified. This test did not indicate an outstanding armor/jacket material.

ZYTEL jacketed samples: although the nylon ZYTEL ST 801 used is substantially harder than HDPE it did not give superior resistance to biting in this test. Bites per 100m of line were higher than the average for all the materials in the same depth zone. The nylon coated line had enough severe bites so that metal was exposed to sea water and in time corrosion would have resulted. A possible reason for its poor performance is the insufficient thickness of the jacket provided with this experimental sample. ZYTEL ST 801 is a compromise material which has good mechanical properties combined with moderate resistance to puncture and cutting.

KEVLAR and SPECTRA Specimen: three specimens of KEVLAR and SPECTRA 3/8 inch ropes with construction as previously described were recovered after one year exposure. The specimens were inspected for fishbites and other signs of deterioration. Numerous small rust spots were noted in the SPECTRA jacket at points of breaks in the coating of the wires. Minor cuts due to fishbite were noted on both types of specimens. All retrieved samples were pull-tested and found to be as strong as new. Based on the absence of significant rope strength degradation and the little damage observed on the periphery of the ropes in zones of active fishbite attacks, it appeared that both types of braided jackets had provided adequate protection, with the steel reinforced SPECTRA braid showing a slightly better performance.

Biting Organism: with one or two exceptions where a slashing attack with deep and regularly spaced cuts typical of shark bites were seen, the great majority of bites were typical of another well documented biter, Sudis hyalina (Haedrich, 1965).

3.3 EVIDENCE OF FISHBITE ACTIVITY ON ESOM II

3.3.1 FISHBITE DISTRIBUTION: the bite record for ESOM II is summarized in Table VIII below.

Table VIII
ESOM II: FISHBITE VS. DEPTH

<u>Depth - Meters</u>	<u>Fishbites/100 m.</u>	<u>Severe Bites</u>
0 - 99	22	9
100 - 199	4	0
200 - 299	1	0
300 - 399	4	0
400 - 499	3	0
500 - 599	4	3
600 - 699	0	0
700 - 799	0	0
800 - 899	7	0
900 - 999	5	0
1000 - 2918	0	0
	—	—
TOTAL	50	12

Overall, 50 fishbites were found. Twenty-eight were on the mooring line, and 22 on other items. Twelve bites were characterized as being severe. Half of them were found on the mooring line and the other six on non-loadbearing test items. The greatest concentration of fishbites was in the top 100m of the array. No fishbites were found below 916m.

Greater than average fishbite attack was indicated in three depth zones: 0-99m with 22 bites, 9 severe; 500 to 599m with 5 bites, 3 severe; and 800 to 999m with 12 bites, all minor.

3.3.2 RESULTS FROM OBSERVATIONS.

Protected samples: three sample lines were severely cut: a ZYTEL (nylon) plastic jacketed steel (Figure 11), a KEVLAR line with a braided KEVLAR cover (Figure 12), and a SPECTRA-fiber line with a braided jacket of polyester and stainless steel wires (Figure 13). The ZYTEL jacketed steel wire rope sample parted after the steel had corroded following exposure to sea water. Similar bites on the adjacent HDPE jacketed steel mooring line pierced the jacket but corrosion had not gone far enough to cause failure of the mooring line. The SPECTRA line was damaged to the extent that there was a large slit in the braided cover, exposing the underlying SPECTRA fibers. The stainless steel wires in the braided jacket were found to have clearly severed ends with no sign of rusting. The parted fibers in both the KEVLAR and SPECTRA ropes were examined microscopically and found to have a high proportion of sharp cut ends, characteristic of

fishbite. In addition to the two fiber lines noted above, there were a number of cut yarns found in the 1/2" diameter polyester rope used to secure the ends of the DACRON test ropes. A study of fiber ends from these ropes indicated that they, too, had been bitten.



FIGURE 11: ZYTEL jacketed steel wire rope

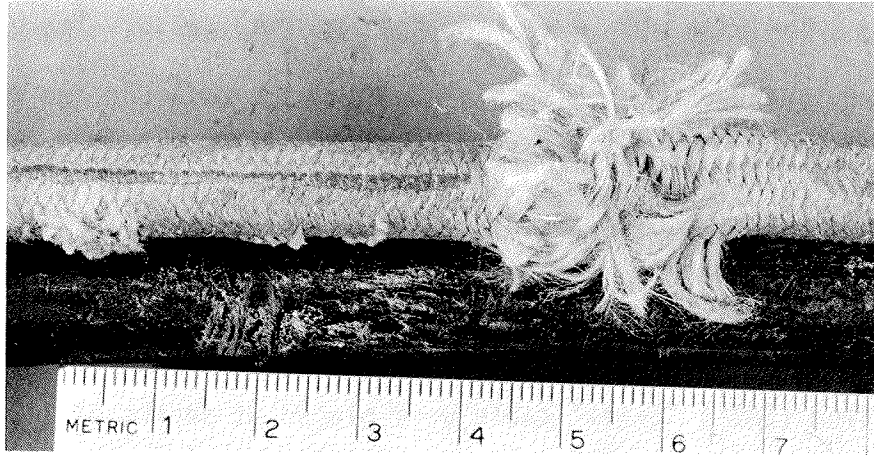

FIGURE 12: KEVLAR jacketed line

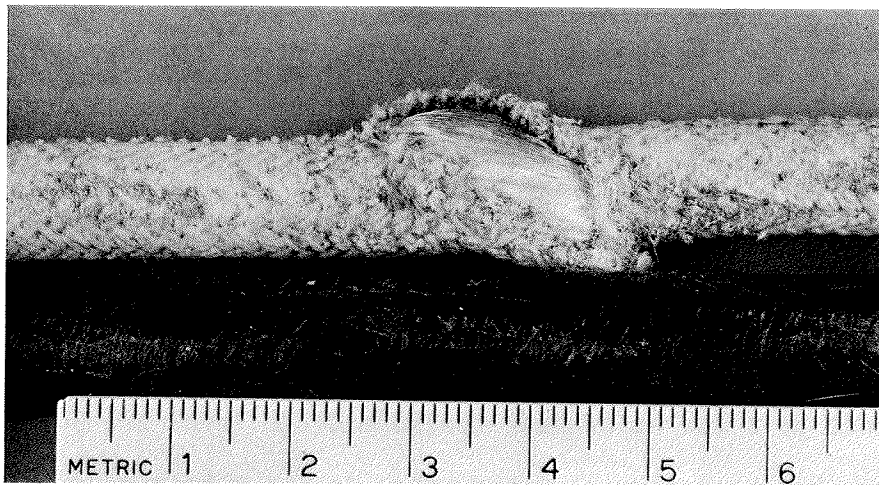

FIGURE 13: Fishbite on SPECTRA line

Clip-on plastic fairings: twenty-seven plastic fairings were placed on the mooring line over a span of 50m (73-123m depth). No severe damage was found on the 15 sections which were returned and examined at WHOI, 10 sections had minor scratches, none of which were positively identified as fishbite.

SAIC "quiet" cable: samples of Science Applications International Corporation (SAIC) "quiet" cable were placed at depths of 123 to 163m and 946 to 976m. One minor fishbite was seen at the upper level on the SAIC cable. The mooring line was not bitten at either level. A very low level of biting activity was found at 123 to 163m depth or at 946 to 976m. A more severe biting environment or longer lengths of line would have provided a better measure of the SAIC cable resistance to fishbite.

Biting organism: no tooth fragments were recovered, but other evidence indicates that both Sudis hyalina and sharks may have been involved. Paired bite marks spaced at 35 to 53 mm. intervals (0.8 to 2.1 in.) with tooth cuts on only one side of the line, and the occurrence of bites at or near the 900m depth level are Sudis hyalina's biting pattern. Other bites in which both sides of the line were cut may have been the work of sharks. Such bites were found at depths ranging from 51 to 466m. Spacing of parallel cuts from 1.5 to

2.5 cm. apart may have been a consequence of tooth spacing and supports the idea that sharks were part of the fishbite attack.

3.4 SIGNIFICANCE OF THE FISHBITE RECORD

3.4.1 THE FISHBITE ATTACK

Measurement of the level of fishbite activity is derived from the number of bites on the HDPE jacketed mooring line, which presents a uniform and low resistance biting medium and retains good dental impressions for study in the laboratory. On ESOM II, 50 bites were observed in 195 days (0.77 bites/day), much less than reported by Turner and Prindle in 1968 from a nearby location, 32°14' N and 64°13' W. On one line in the water for 55 days, they found 256 bites over a depth range of 100 to 1600m; and on a second line in the water for 82 days at the same location, they found 697 bites (8.28 bites/day) over a range of 50 to 1500m. Bites were attributed to Sudis hyalina.

The intensity of fishbite activity on ESOM II, 0.77 bites/day, was greater than that encountered on ESOM I in which 120 bites were found in a period of 381 days; a rate of 0.31 bites/day. Other fishbite data [11] have indicated that the number of fishbites may not be directly related to the time a line is in the water and that some bites occur during launching and recovery operations.

In the present case, 28 bites were found on the mooring line and 22 on test items attached to it (see TABLE IX). To have fewer bites on the test items is logical, unless they are unusually attractive, because the test items do not fully overlap the length of the mooring line.

Table IX
FISHBITES ON MAIN MOORING LINE
VS. FISHBITE TEST SAMPLES

<u>Col I</u>	<u>Col II</u>	<u>Col III</u>	<u>Col IV</u>	<u>Col V</u>
<u>Depth</u> <u>m</u>	<u>Bites/100m</u> <u>on HDPE</u> <u>jacketed</u> <u>Mooring Line</u>	<u># Bites</u> <u>Observed On</u> <u>Bite Test</u> <u>Samples</u>	<u>% of Line</u> <u>Occupied by</u> <u>Bite Test</u> <u>Samples</u>	<u># Bites</u> <u>"Expected" on</u> <u>Bite Test</u> <u>Samples</u>
0- 99	15	7	60	9
100-199	0	4	90	0
200-299	1	0	100	1
300-399	4	0	0	0
400-499	2	1	60	1
500-599	1	3	80	1
600-699	0	0	0	0
700-799	0	0	0	0
800-899	1	6	80	1
900-999	4	1	90	4
1000+	0	0	0	0
TOTAL	28	22		17

3.4.2 MEASUREMENT OF FISHBITE RESISTANCE

The fishbite data from ESOM II are presented again in Table IX. Using data obtained by counting fishbites on the mooring line, at depths indicated, the probable number of bites for each test item has been computed and compared with numbers of bites actually found on each. There is little consistency in the numbers. Sometimes a test line was attacked when the control picked up no bites and vice versa. Apparently, bites were rare enough that it was a matter of chance whether or not a sample was bitten.

Two other factors which probably influenced the bite data were:

- Slippage of lines through the clamps used to hold them together. This could put separate pairs of bites on test items and the adjacent mooring line, causing false conclusions with regard to their relative susceptibility to biting.
- Tension on each of the paired lines was not controlled. In general tension on a plastic jacketed line reduces bite resistance; tension on a braid covered line increases resistance to cutting and stabbing.

3.5 FISHBITE TEST SUMMARY AND CONCLUSIONS

- a) The fishbite attacks on ESOM I and ESOM II were of moderate intensity, compared to past records.
- b) Three fishbite test lines, ZYTEL nylon on steel, KEVLAR rope with a KEVLAR braid cover, and a SPECTRA rope with SPECTRA and stainless steel braid jacket each were bitten severely enough during ESOM II to destroy their value as mooring lines.
- c) The attempt to get a measure of fishbite resistance of various plastics using short lengths of plastic tubes yielded scant bite information.
- d) No usable fishbite evidence was forthcoming from the trial of plastic fairing.
- e) SAIC "quiet" cable samples were placed where fishbite attack was extremely weak. One minor bite was found. Further testing in a more rigorous environment would be desirable.
- f) The effects of possible slippage of the samples mounted in parallel, during deployment and recovery, should be recognized and eventually corrected.
- g) Means for maintaining the samples mounted in parallel under tension should be devised.

4.0 ACOUSTIC TELEMTRY

4.1 BACKGROUND

Over the past several years WHOI has developed an underwater acoustic telemetry system for mooring applications. The hardware is compact and power efficient and provides a reliable telemetry link over the vertical channel at rates up to 1200 b/s. The system is designed for applications requiring communication between a number of remote modems and a single master. Thus, each instrument on a mooring can be equipped with a small, low power acoustic modem which can transfer data to a master modem located on a surface buoy or ship. Each subsurface modem has a very low power receiver which is used for polled operation to minimize power consumption during standby. Detailed descriptions of the acoustic modems can be found in previously published articles [12], [13], and [14]. The motivations and uses of data telemetry in oceanography are discussed in [15] and [16].

The acoustic modems deployed on the ESOM project were designed at WHOI and are built under license by Datasonics, Inc. of Cataumet, MA. Development of reliable, high speed, low power acoustic telemetry is continuing at WHOI with work ongoing in areas of high baud rate horizontal telemetry, long range horizontal telemetry, and new modulation techniques.

4.2 ACOUSTIC TELEMTRY EXPERIMENT

Acoustic telemetry modems were installed on the ESOM mooring as a test of their long-term reliability in an operational environment. In

the test system, shown in Figure 14, modems were deployed at depths of 300, 1500 and 2900m and communicated with a master modem with hydrophone installed in the surface buoy. Data acquisition, processing and telemetry to shore (via satellite link) was controlled by an Instrument Bus Computer (IBC), a low power 80C86-based controller developed at WHOI [17].

The test program was designed to collect data from each modem over a period of six months. Subsurface modems were polled from the surface by transmission of a unique address followed by a data request. These polls were received and decoded by each modem and answered by only the modem addressed. Polling was performed three times per hour for the 1500 and 2900m modems and once per hour for the 300m modem. In addition, each subsurface modem initiated an unpolled data transfer once per hour to test system operation in a random access mode.

The data in each case was a known sequence of characters that could be used to compute the Bit Error Rate (BER) and Signal to Noise Ratio (SNR) for each transmission. The master modem computed BER and SNR for each transmission and passed these data to the IBC for telemetry to shore along with various housekeeping data. A four-ID, 32-buffer Argos PTT allowed the transmission of up to 25 kb per day via the Argos system.

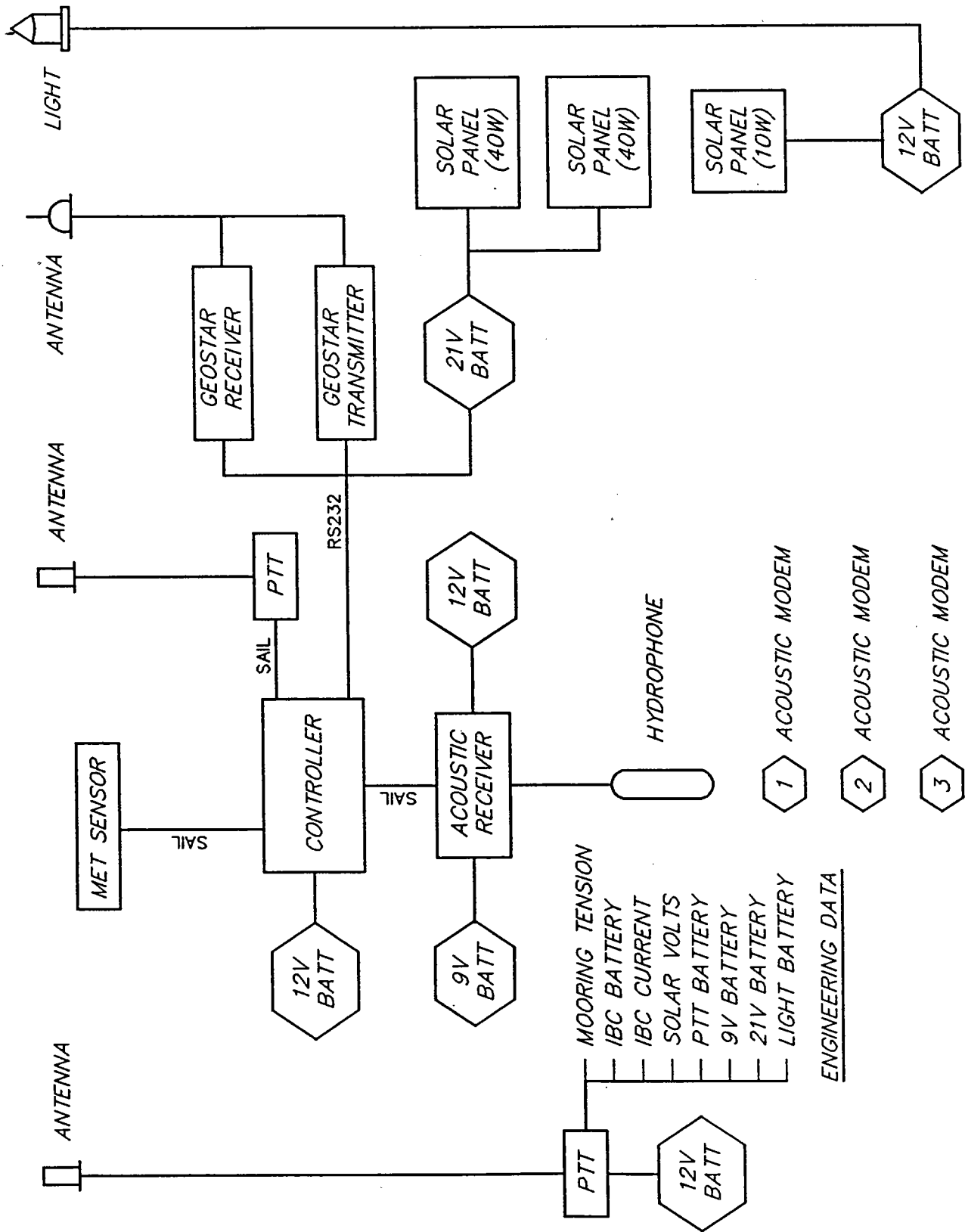

FIGURE 14: ESOM II Electronic schematics

Acoustic modems deployed on the ESOM mooring transmitted data at 600 b/s using MFSK modulation. They were equipped with directional hydrophones and transmitted 10W acoustic in the 15-20 kHz frequency band. Each modem was equipped with a low power receiver capable of decoding FSK signals transmitted by the surface modem at 10 b/s. The surface modem used an AT&T Digital Signal Processing (DSP) chip, the DSP32C, to decode the MFSK signals in real time. Its directional hydrophone was mounted on the bottom of the buoy and was back-baffled to reduce surface generated noise by a SURLYN foam collar providing 40 db of front-to-back quieting.

The surface buoy was also equipped with a Geostar transceiver [18] and secondary Argos PTT for redundant data telemetry and location, respectively. Unfortunately, the Geostar transceiver, a commercial, two-way satellite data link developed for position and data relay use in the transportation industry, failed to function properly due to a power supply problem. The data meant to be telemetered via Geostar, however, was also sent via Argos so no data were lost.

Prior to deployment of the ESOM mooring, two acoustic modems were lowered from the R/V Oceanus to 2700m depth to confirm their proper operation. Under calm sea conditions, with the receive hydrophone deployed at a depth of 6m, the average BER for both modems was about 4×10^{-4} (Figure 15). Only two of the data packets had more than four bit errors. BER at 2700m was only slightly higher than at 1000m and above.

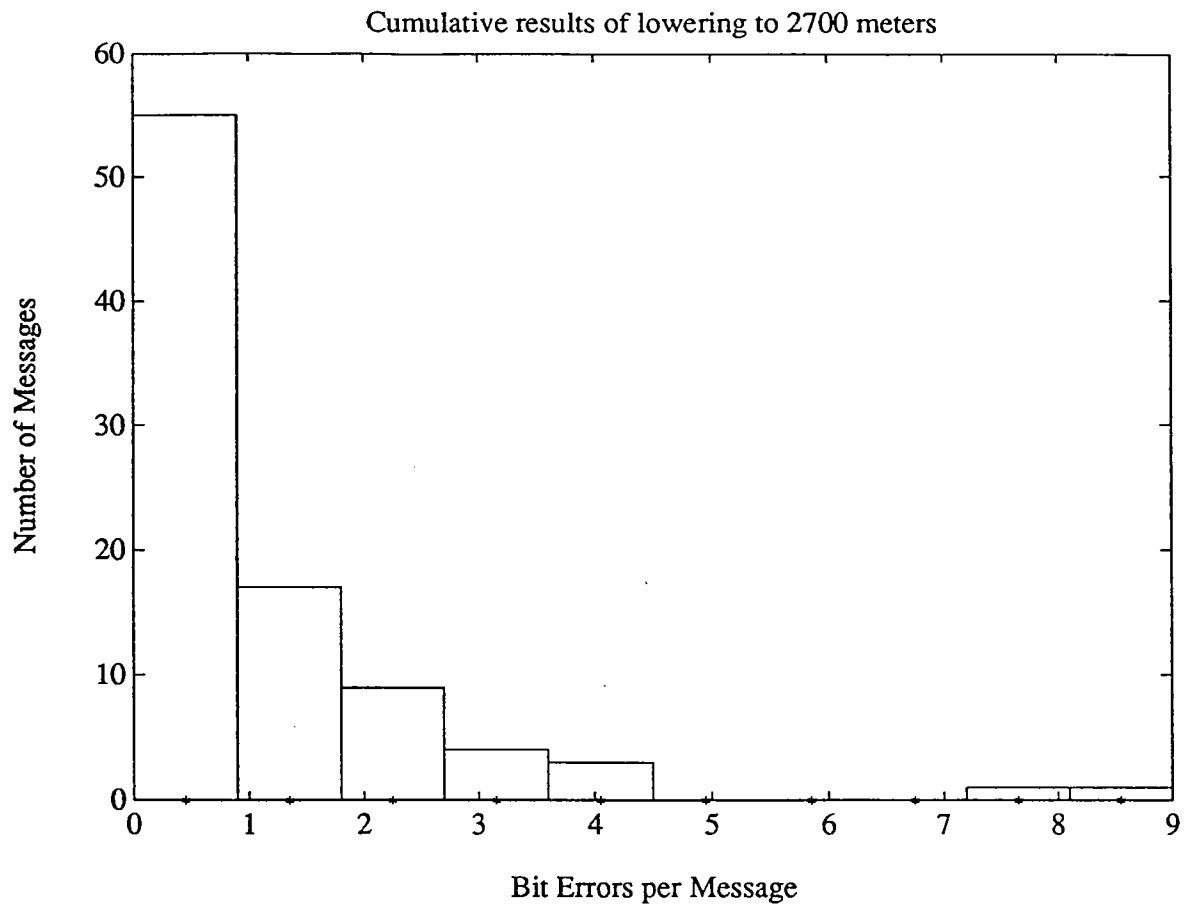

FIGURE 15: Cumulative results of lowering to 2700m

After the modem lowering, the ESOM buoy was installed and data were collected regularly over the next six months. Figure 16 (from [14]) show results from the modem deployed at 1500m. This modem operated for the full six month period and transmitted over 20×10^6 data bits at a BER that ranged from 1×10^{-2} to 1×10^{-4} and averaged 1.45×10^{-3} . The other two modems operated much less consistently. The modem at 300m was damaged prior to or during deployment and suffered from a reduced transmit power level. As a result, its performance was marginal. The deep modem, deployed at 2900m failed after 32 days due to an electronic problem. During the time it operated, the average BER for its transmission exceeded 10% and its SNR was of the order of 2 dB, well below the performance level expected based on data from the shipboard lowering. Analysis of the system performance following the mooring retrieval suggests that high levels of surface-generated background noise masked the signal from the 2900m modem. Signal strength from the 1500m modem was higher and its data were seriously degraded much less frequently. Typical SNR for the 1500m modem was 10dB.

The source of the noise is believed to be surface waves and their interaction with the surface buoy and the hydrophone mounting system. This conclusion is based on data shown in Figure 17 (from [14]), which shows daily averaged wind speed at the Bermuda Naval Air Station (20km north of the mooring site) plotted above daily average BERs for the 1500m modem. A clear correlation between high average winds (and presumably high sea state) and high BER is evident.

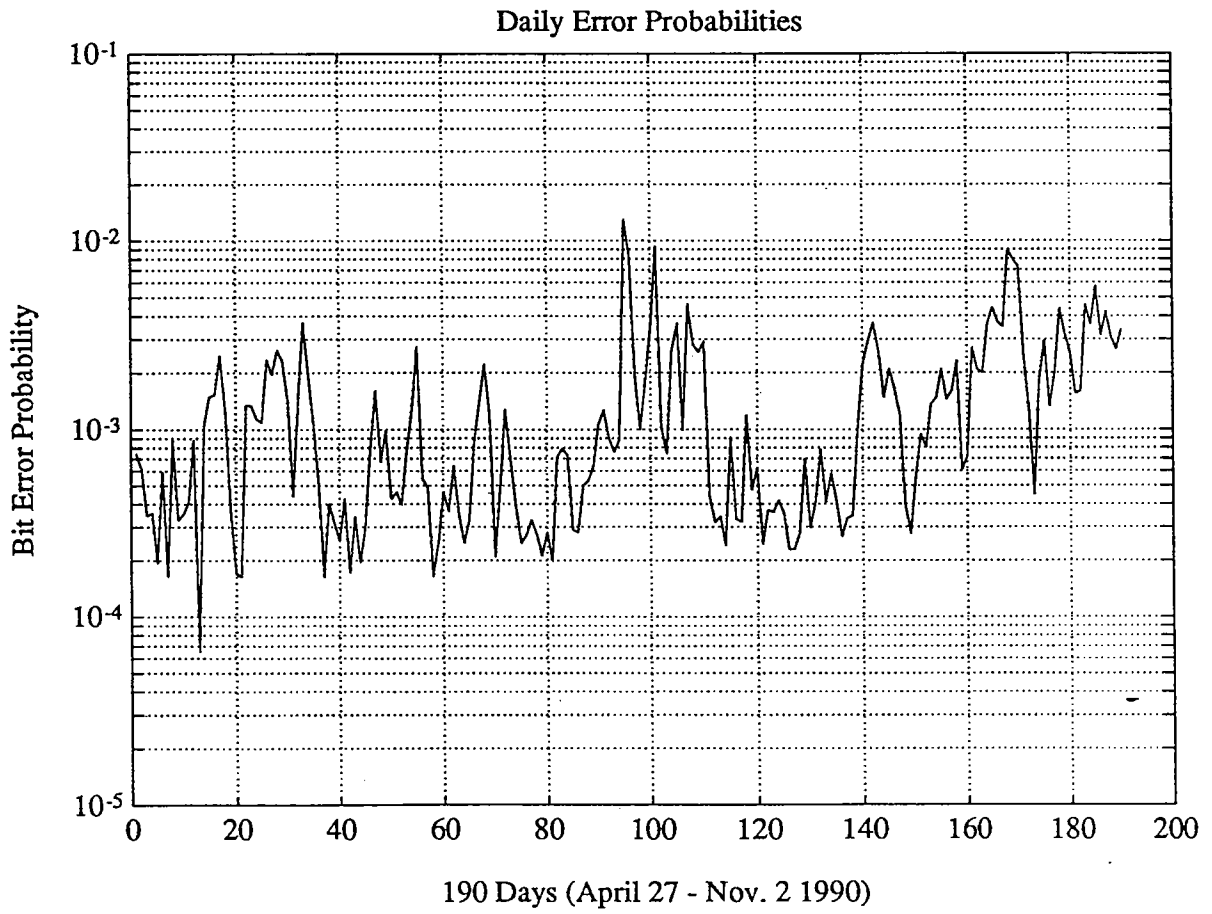

FIGURE 16: Data record from modem at 1500m

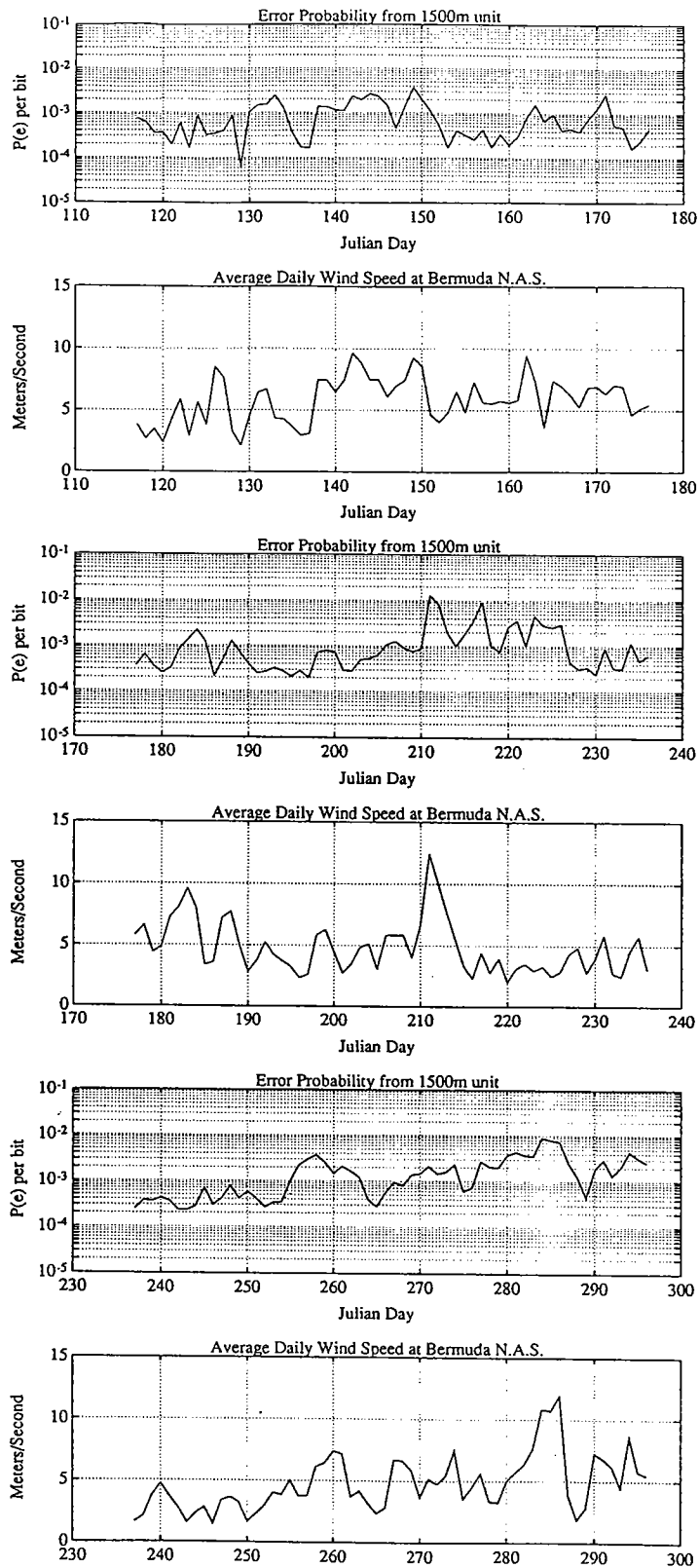

FIGURE 17: Wind speed and error probability data record

5.0 CONCLUSIONS

The ESOM project most important results can be summarized as follows:

- The foam hull and the aluminum tower of the surface buoy have been found to be in excellent shape after 18 months at sea.
- All samples of wire ropes and mooring hardware (shackles, links) were found in excellent condition, with no signs of deterioration or loss of strength due to corrosion or fatigue. The back-up flotation chain was severely weakened by the 18 month deployment.
- Two kinds of electromechanical cables were exposed at sea: 1) a 3x19 wire rope with three conductors, each inserted in the valley between the strands, and protected by steel ropes and outer HDPE jacket, and 2) a 3x18 wire rope with one conductor in the center of each strand. Both kinds of cables performed well (no loss of conductivity nor insulation). The 3x19 had been previously used at sea on the STEM experiment. The 3x18, a cable with better conductor protection and simpler construction had never been used on the surface mooring line before. The success of this cable is a significant achievement of the ESOM experiment.
- The low cost electromechanical terminations developed in house for these cables proved to be marginal. Their design shortcomings

have been identified and recommendations made for their improvement.

- Tight braids of KEVLAR and of steel reinforced SPECTRA were shown to provide a measure of protection against fish bites. However, the mesh weight used, which was based on protective clothing design, was not sufficient to protect the line against all fishbite activity. We plan to fabricate synthetic lines with several mesh weights to see if we can maximize the protection without excessive weight or cost.
- The long-term telemetry test demonstrated the viability of the acoustic telemetry link for moored applications. It also brought to light the need for an improved hydrophone mounting system to reduce the effects of surface generated noise. Based on the results obtained on this project, we have continued system development and have improved BER performance by about an order of magnitude. These refinements include the addition of error correction coding in the receiver and the optimization of the FFT algorithms in the receiver which has increased SNR substantially (10db). Still to be accomplished are implementation of Automatic Repeat Request (ARQ) protocols which will allow erroneous packets to be resent and diversity reception which will combine the output of two or more receive hydrophones in the optimum manner to combat signal fades.

The advantages of occupying an open ocean, deep sea site, near adequate shore facilities for mooring services and eventual recovery, have been demonstrated. The experience gained by ESOM can now be put to good use for the conduct of more complex, long term experimental programs. The original objective of maintaining a deep sea surface mooring with a service life of one year or more has been achieved.

REFERENCES

1. Bocconcelli, Alessandro, "Engineering Surface Oceanographic Mooring (ESOM)", Proceedings OCEANS '89, pp.1381-1385. (WHOI Contribution No. 7170).
2. Berteaux, Henri O., Prindle, Bryce and Putnam, Susan S., "Monitoring Fishbite Activities and Protecting Synthetic Fiber Ropes Used in Deep Sea Mooring", Proceedings OCEANS '90, pp. 301-312 (WHOI Contribution No. 7432).
3. Bocconcelli, Alessandro, "Engineering Surface Oceanographic Mooring (ESOM)-Cruise Report", WHOI, unpublished paper, Nov.1990
4. Berteaux, Henri O., Bocconcelli, A., Gould, M. and Kery, S., "Testing and Evaluation of SURLYN Foam and Spectra Fiber Ropes for Buoy System Applications", Technical report, WHOI -88-32.
5. Bocconcelli, Alessandro, "A Novel Hemispherical Surface Buoy", Proceedings MTS Buoy Technology Workshop, Woods Hole, April 1991.
6. Berteaux, H. O. and Boy, Richard L., "Wave Tank Study of Moored Buoy Hulls for Air Sea Interaction Application", Proceedings Oceans '86, pp.259-270 (WHOI Contribution No.6211).
7. Lucht, W.A. and Donecker, F.W., "Factors Affecting Wire Rope Life in a Marine Environment", Proceeding 9th Offshore Technology Conference, Houston, May 1977.
8. Bocconcelli, Alessandro, "Development and Evaluation of Electromechanical Cables for Deep Sea Buoy Applications", Technical Report, WHOI - 91-02.

9. Berteaux, Henri O., Frye, D. E., Clay, P. R. and Mellinger, E. C., "Surface Telemetry Engineering Mooring", Proceedings OCEANS '88, pp. 670-680 (WHOI Contribution No. 6862).
10. Lucht, Al, "EM Cable Failure Report", December 1990, Unpublished report.
11. Berteaux, Henri O. and Prindle, Bryce, "Deep Sea Moorings Fishbite Handbook", Technical report, WHOI - 87-8.
12. Catipovic, J.A., Deffenbaugh M., Freitag L.E. and Frye D.E., "An acoustic telemetry system for deep ocean mooring data acquisition and control", Proceedings, Oceans '89, pp.887-892.
13. Catipovic, J.A., Frye, D. and Porta, D., 1990. "Specifications and applications for an advanced acoustic telemetry system", Oceanology International Proceedings, March 1990.
14. Freitag, L.E., Merriam, S.J., Frye, D.E. and Catipovic, J.A., " A long term, deep-water acoustic telemetry experiment", Proceedings, Oceans '91, in press.
15. Briscoe, M.G. and Frye, D.E., "Motivation and methods for ocean data telemetry", Marine Technology Society Journal, vol. 21, no. 2, pp.42-57, June 1987.
16. Frye, D.E. and Owens, B. W., "Recent developments in ocean data telemetry at Woods Hole Oceanographic Institution", IEEE Journal of Oceanic Engineering, October 1991, in press.
17. Mellinger, E.C., Prada, K.E., Koehler, R.L. and Doherty, K.W.,

Instrument bus - an electronic systems architecture for oceanographic instrumentation, Woods Hole Oceanographic Institution Technical Report WHOI-86-30, August 1986

18. Stoddard, R., "Geostar: RDSS on the move", Satellite Communications, pp 22-24, October 1986.

APPENDIX A: ESOM E/M CABLE #20 FAILURE REPORT



Office Memorandum

Date: December 19, 1990
To: H.O. Berteaux and A. Bocconcelli
From: R.G. Walden
Subject: ESOM EM Cable #20 (ESOM II)

Subject cable was tested after the ESOM II exposure and found to exhibit intermittent and high resistance from end to end in two of the three conductors. Values of 250 to open circuit were observed from pins 1 and 2 from one end to the other. The conductor (red) connected to pin 3 measured a normal value of 4 ohms.

In order to isolate the defective conductors the pigtails on each end were cut off a few inches from the swaged termination. This permitted separate measurements of the cable alone and each pigtail consisting of the polyurethane molded puck which connects the conductors of the EM cable to the pigtail assembly and the associated electrical connector.

The intermittently open section of cable #20 was found to be in the upper pigtail section, about two feet from the puck between the puck and the connector. This section was coiled up to reduce its slack length and held with tape. No mechanical damage was observed to the exterior black polyurethane jacket, however, one of the two bad wires (black) showed signs of pinching. The other intermittently open wire (white) showed no such signs.

Conclusions:

The lack of damage on the outside jacket of the pigtail cable would seem to eliminate conductor damage from an external source. This would include pinching or fishbite damage. However, one wire (black) showed unmistakable evidence of pinching at the point of the break. It might be concluded that this was a defective wire which was included in the 3 conductor pigtail at the time of manufacture. The white wire has a break in the copper at about the same point and can be readily seen by bending the wire. There appears to be no external marks on the insulation at this point. It is unlikely that there would be two manufacturing defects which would end up at the same point in the two wires in the finished cable.

It was previously mentioned that excess length in the pigtail was coiled up and taped in one place into about 5 turns in a 6" diameter. One of the turns had evidently pulled tight into a 1" turn. This is about the point where the breaks were found.

I conclude that the breaks were caused in some way associated with the need to shorten the pigtail by coiling it up, taping it to hold the coil shape and then probably taping or tying off this coil, to either the swaged fitting or the dual continuity meter item #19. There was tension on the cable as evidenced by one turn being pulled quite tight. A combination of tension and cyclic bending could very probably fatigue the individual copper wires thus causing the observed intermittent open circuit.

Recommendations:

- o Extra long pigtails should be avoided. Bundling up any excess wire will just exhibit a point of high drag in the assembly which will accentuate current induced motion. Pigtails, should probably be enclosed in tubing or piping if possible. Extreme care should be given to choosing the proper length of the pigtail, neither too long nor too short.
- o The present technique of making the polyurethane splice puck appears to be wholly satisfactory as no leaks or shorts were found. Continue to use.
- o The connectors used in this mooring were found to be in like new condition. Continue to use.
- o The swaged EM terminations in item #20 were successful. While there was no sign of damage or fatigue to the 3x18 EM cable at the exit point from the swaged fitting, results of the investigation of the failure cause of item #16 may indicate changes (better waterproofing, more strain relief, etc.) should be made.
- o The 3x18 cable in item #20 appears to be in excellent condition. This cable design should be utilized in the future unless the results of the item #16 investigation indicate otherwise.

APPENDIX B: VMCM TEST REPORT

Memorandum

TO: R. Weller, D. Hosom, R. Trask, J. Dean
FROM: P. Bouchard, C. Marquette
SUBJECT: Bearing evaluation, ESOM II
DATE: 1 FEB 91

A bearing comparison was done under the ESOM round bottom buoy again off of Bermuda for 6 months. This time there were five different sets of bearings. An active VMCM had MPB 3/8 440 S.S. bearings. A test sting had BARDEN 3/8 440 S.S. bearings. One test sting had NMB 3/8 440 S.S. bearings. Another test sting had WHOI 3/8 TUNGSTEN CARBIDE bearings. The last test sting had 3/8 SHAMBAN bearings. The condition of the bearings when they came back from sea is as follows.

3/8 440 S.S. bearings: MPB P/N SR6MCKHH 5

The condition of the active instrument upon recovery was that it had a small amount of green-hair growth on the end cap base of the sting. These bearings were new. The moored depth was 27 meters. AMERON blue antifouling paint was used on the instr. The paint on the blades showed little to no signs of flexing in the paint. The cage anodes and the case anodes were 50% gone. The propellor shaft anodes were 50% to 80% gone.

The upper and lower hubs looked similar when inspected. There was much aragonite precipitate inside the hubs. The bearings and hubs appearance were similar to previous deployments. The spin down times of the upper shaft were poor. The props spun smoothly but stiff. The axial end play was .000. The lower props spun smoothly, sounded a little rough but clogged when stopping. The axial end play was .003 and the spin down times were good. All of the bearings showed signs of corrosion. As in previous deployments the c-ring showed signs of corroding and even broke when removing.

3/8 440 S.S. bearings: BARDEN P/N SR6SSTB5

The condition of this test instrument was that there were no signs of growth and the paint on the cage was 70% gone. These bearings were new. The moored depth was 63 meters. The lower hub was missing 1 blade and the blades showed signs of flexing in the paint. These bearings were mounted on a test sting with a PVC base. The PVC post at the base cracked and the sting rotated freely. The condition of the bearings and hub assy's were the same as the MPB 440 S.S. bearings. The axial end play was .000, for both upper and lower hubs. The spin down times were poor also. The props were tight but spun smoothly. The C-rings, bearings, and shims were all corroding.

3/8 440 S.S. bearings: NMB P/N SSR1438ZKC

These were new bearings. The condition of this test sting was exactly the same as the BARDEN 3/8 440 S.S. test sting. The moored depth was 39 meters.

3/8 WHOI TUNGSTEN CARBIDE bearings: John Thomson

These bearings were previously used for 5 months on FASINEX under a discus buoy, and 8 months on PRESUBDUCTION also under a discus buoy. This test sting was in a PVC base but the base was not broken and the sting was secure in the cage. The moored depth was 15 meters, under a round bottom buoy. The sting showed signs of the props rubbing against the sting. There was some green-hair growth and the paint was 70% gone from the cage. The cage anodes were 50% gone. The axial end play was .008 for the upper hub and .003 for the lower hub. The spin down times on these bearings were the best of all bearings used on ESOM II. The upper bearings had SILICON NITRIDE balls and the lower had TUNGSTEN CARBIDE balls. Upon inspection of the lower hub bearings, there appeared to be small amounts of aragonine deposits, on one of the bearings, around the inside of the outer race, on the side away from the hub. On another bearing there was some low density hair growth on the retainer but didn't overlap onto the races. There was also a slight amount found on the inside of the same retainer. There were small amounts of deposits of corrosion due to no zinc protection on the sting. The bearing on the magnet ring side of the upper hub, when installed had a chip on the inner race which occurred upon previous removal. When removed this time it was chipped again. The bearing on the side opposite the pressure window lower hub was also chipped when removed. The c-rings all were corroding. The bearings appeared to have little to no wear, therefore we will clean and redeploy for another test.

3/8 DUROBALL bearings: SHAMBAN P/N CR0628

These were new bearings. The test sting had a PVC base and the post cracked and allowed the sting to rotate freely. The moored depth was 51 meters. The blades showed signs of flexing in the paint and the paint was 70% gone from the cage. Upon inspection of the bearings there appeared to be little to no wear, see measurements. Some white deposits, from sting corrosion, were found on the races and the balls of 1, of the 4 used bearings. The other 3 bearings showed a slight bit of deposits. The bearings were washed in an ultrasonic cleaner with warm water and the deposits were gone. Under a micro-scope, the balls and races were examined. The surfaces of the balls were pitted, so we examined some new balls, and that too showed similar pitting. The races on the used bearings were also pitted, so we examined new races and they showed roughness from fabrication. The spin down times with the shaft horizontal were good and the props cogged when stopping. The spin down times when the shaft was vertical were poor and the props wobbled and didn't cog. The c-rings were all corroding. Do to the spin down chart, these bearings are not acceptable.

In conclusion, the BARDEN 440 S.S. bearings, the NMB 440 S.S. bearings, the SHAMBAN bearings are not recommended to be used. The WHOI TUNGSTEN CARBIDE bearings have had about 19 months of use and will be put out again for another test. New MPB 440 S.S.

bearings will also be deployed again for a comparison. The c-rings have been change to 316 S.S. and so have the shims, therefore there should not be any corrosion due to dissimilar metals.

Photographs of these bearings are on file with Rick Trask.

SHAMBAN bearings:

MEASURMENTS

	NEW	USED ESOMI
Inner race:	.4670 - .4705	.4685 - .4700
Outer race:	.780	.780
Ball diam.:	.153 - .155	.153 - .155

SPIN DOWN CHART

	NEW	USED ESOMII
Vertical:	14 sec.	14 sec.
Horizontal:	60 sec.	56 sec.

PB/CM/pf

cc: P. Bouchard; C. Marquette

APPENDIX C: ENGINEERING INSTRUMENT SPECIFICATIONS AND FEATURES

Engineering Instrument Specifications and Features

Grade III Titanium Pressure Housing

Length = 99 cm (39 in)

O.D. = 15 cm (6 in)

ID = 13 cm (5.25 in)

Weight in air = 33 kg (72 lbs)

Weight in water = 18 kg (40 lbs)

Safe working tension = 4545 kg (10,000 lbs)

Safe working depth = 6740 (10,000 psi)

Sensors and Circuitry (range, accuracy and resolution)

Temperature - Thermistor type sensor

0 to 27 deg. C. \pm 0.1 deg. C.

resolution - 0.1 deg. C.

Tilt - Bell and Howell strain-gauge accelerometers for X and Y
tilt measurements

0 to 60 deg. \pm 1 deg.

resolution = 0.5 deg.

Tension - End cap piston coupled to a semiconductor strain-gauge pressure transducer with continuous automatic pressure compensation. 3 selectable ranges as follows:

- 0 to 3759 kg \pm 23 kg; resolution = 14.8 kg
(8270 lbs \pm 50 lbs; resolution = 32.5 lbs)
- 0 to 1504 kg \pm 9 kg; resolution = 6 kg
(3308 lbs \pm 20 lbs; resolution = 13.0 lbs)
- 0 to 376 kg \pm 2.5 kg; resolution = 1.6 kg
(826 lbs \pm 5 lbs; resolution = 3.5 lbs)

Depth - Semiconductor strain-gauge pressure transducer 4 selectable ranges as follows:

- 0 to 340 \pm 1.5 M., resolution = 1.3 M.
- 0 to 680 \pm 3.0 M.; resolution = 2.7 M.
- 0 to 1350 \pm 5.0 M.; resolution = 5.3 M.
- 0 to 6740 \pm 27 M.; resolution = 26.4 M.

These span ranges can be offset in 33 meter increments from 0 to 6740 meters. This allows greater flexibility in selecting accuracy and resolution in the deeper end of the mooring.

ENGINEERING INSTRUMENT OTHER FEATURES

- o Solid state programmable memory for data storage (256K).
- o Duty-cycled user selection of sampling interval.
- o Burst sampling is available.
- o Number of channels recorded is user selectable.
- o No moving parts.
- o Offload software has been developed for data storage on floppy disks (for IBM PC AT).
- o 18-Volt alkaline battery pack that well exceeds the power requirements to completely fill the memory space. (Memory space is the only limiting factor in regards to instrument deployment time).



DOCUMENT LIBRARY

March 11, 1991

Distribution List for Technical Report Exchange

Attn: Stella Sanchez-Wade
Documents Section
Scripps Institution of Oceanography
Library, Mail Code C-075C
La Jolla, CA 92093

Hancock Library of Biology &
Oceanography
Alan Hancock Laboratory
University of Southern California
University Park
Los Angeles, CA 90089-0371

Gifts & Exchanges
Library
Bedford Institute of Oceanography
P.O. Box 1006
Dartmouth, NS, B2Y 4A2, CANADA

Office of the International
Ice Patrol
c/o Coast Guard R & D Center
Avery Point
Groton, CT 06340

NOAA/EDIS Miami Library Center
4301 Rickenbacker Causeway
Miami, FL 33149

Library
Skidaway Institute of Oceanography
P.O. Box 13687
Savannah, GA 31416

Institute of Geophysics
University of Hawaii
Library Room 252
2525 Correa Road
Honolulu, HI 96822

Marine Resources Information Center
Building E38-320
MIT
Cambridge, MA 02139

Library
Lamont-Doherty Geological
Observatory
Columbia University
Palisades, NY 10964

Library
Serials Department
Oregon State University
Corvallis, OR 97331

Pell Marine Science Library
University of Rhode Island
Narragansett Bay Campus
Narragansett, RI 02882

Working Collection
Texas A&M University
Dept. of Oceanography
College Station, TX 77843

Library
Virginia Institute of Marine Science
Gloucester Point, VA 23062

Fisheries-Oceanography Library
151 Oceanography Teaching Bldg.
University of Washington
Seattle, WA 98195

Library
R.S.M.A.S.
University of Miami
4600 Rickenbacker Causeway
Miami, FL 33149

Maury Oceanographic Library
Naval Oceanographic Office
Stennis Space Center
NSTL, MS 39522-5001

Marine Sciences Collection
Mayaguez Campus Library
University of Puerto Rico
Mayaguez, Puerto Rico 00708

Library
Institute of Oceanographic Sciences
Deacon Laboratory
Wormley, Godalming
Surrey GU8 5UB
UNITED KINGDOM

The Librarian
CSIRO Marine Laboratories
G.P.O. Box 1538
Hobart, Tasmania
AUSTRALIA 7001

Library
Proudman Oceanographic Laboratory
Bidston Observatory
Birkenhead
Merseyside L43 7 RA
UNITED KINGDOM



REPORT DOCUMENTATION PAGE	1. REPORT NO. WHOI-91-34	2.	3. Recipient's Accession No.
4. Title and Subtitle ESOM I and II Final Report			5. Report Date November, 1991
			6.
7. Author(s) Alessandro Bocconcelli, Henri Berteaux, Daniel E. Frye and Dr. Bryce Prindle			8. Performing Organization Rept. No. WHOI-91-34
9. Performing Organization Name and Address Woods Hole Oceanographic Institution Woods Hole, Massachusetts 02543			10. Project/Task/Work Unit No.
			11. Contract(C) or Grant(G) No. (C) N00014-90-J-1719 (G)
12. Sponsoring Organization Name and Address Office of Naval Research			13. Type of Report & Period Covered Technical Report
			14.
15. Supplementary Notes This report should be cited as: Woods Hole Oceanog. Inst. Tech. Rept., WHOI-91-34.			
16. Abstract (Limit: 200 words) An Engineering Surface Oceanographic Mooring (ESOM) program was initiated in 1989 by the Woods Hole Oceanographic Institution for the purpose of evaluating the long term, in situ performance of new moored array materials and sensors. For logistic and practical reasons, a site 12 miles southwest of Bermuda, with a water depth of 3000m was selected to deploy the mooring. Following well established design practice the upper part of the mooring down to a depth of 1900m was made of plastic jacketed, steel armored wire ropes and cables. Groups of test samples were attached at different depths to the main mooring line. The lower part of the mooring was made of compliant, plaited nylon rope. The mooring was deployed in March 1989. It was recovered and reset, with a vertical acoustic telemetry prototype system, in April 1990. The at-sea phase of the program ended in November 1990 when the termination of a test cable failed and the mooring broke loose. The entire mooring was recovered and all of its samples and components were carefully inspected and tested. In addition to the novel acoustic link, mooring components tested included new wire ropes, new electromechanical cables and their terminations, low drag fairings, fishbite resistant jackets, and a new type of surface buoy.			
17. Document Analysis a. Descriptors mooring components fishbite acoustic telemetry b. Identifiers/Open-Ended Terms c. COSATI Field/Group			
18. Availability Statement Approved for public release; distribution unlimited.		19. Security Class (This Report) UNCLASSIFIED	21. No. of Pages 85
		20. Security Class (This Page)	22. Price

