

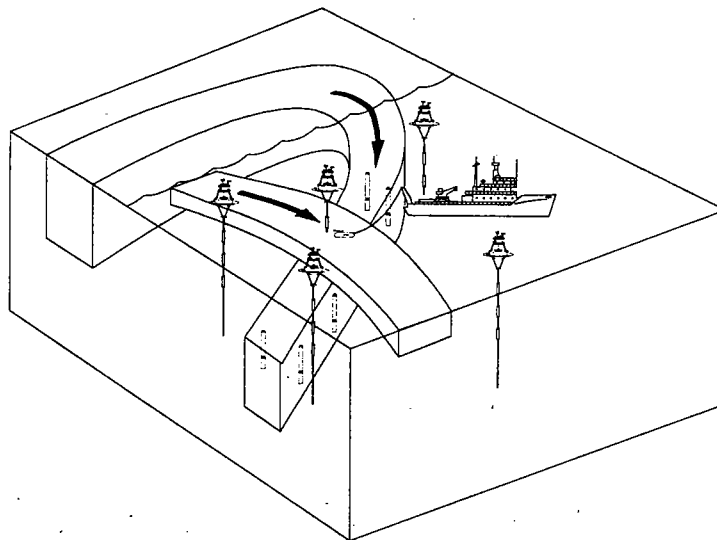

The Subduction Experiment



Cruise Report
R/V *Oceanus*
Cruise Number 240 Leg 3
Subduction 1 Mooring Deployment Cruise
17 June – 5 July 1991

by

Richard P. Trask
Nancy J. Brink

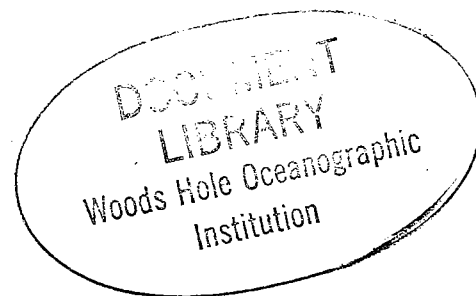

Upper Ocean Processes Group
UOP Technical Report 93-1

**WHOI-93-12
UOP Report 93-1**

**The Subduction Experiment
Cruise Report
R/V *Oceanus*
Cruise Number 240 Leg 3
Subduction 1 Mooring Deployment Cruise
17 June - 5 July 1991**

by

Richard P. Trask
Nancy J. Brink

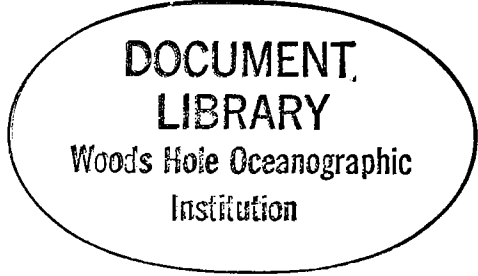

**Upper Ocean Processes Group
Woods Hole Oceanographic Institution
Woods Hole, Massachusetts 02543**

March 1993

Technical Report



Funding was provided by the Office of Naval Research under contract N00014-90-J-1490.

Reproduction in whole or in part is permitted for any purpose of the United States Government. This report should be cited as:
Woods Hole Oceanog. Inst. Tech. Rept., WHOI-93-12.

Approved for publication; distribution unlimited.

Approved for Distribution:

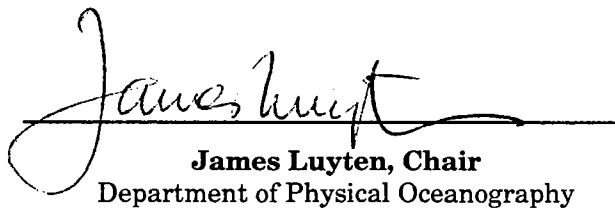
James Luyten, Chair
Department of Physical Oceanography

Abstract

Subduction is the mechanism by which water masses formed in the mixed layer and near the surface of the ocean find their way into the upper thermocline. The subduction process and its underlying mechanisms were studied through a combination of Eulerian and Lagrangian measurements of velocity, measurements of tracer distributions and hydrographic properties and modeling.

An array of five surface moorings carrying meteorological and oceanographic instrumentation were deployed for a period of two years beginning in June 1991 as part of an Office of Naval Research (ONR) funded Subduction experiment. Three eight month deployments were planned. The initial deployment of five surface moorings took place during the third leg of R/V Oceanus cruise number 240. The moorings were deployed at 18°N 34°W, 18°N 22°W, 25.5°N 29°W, 33°N 22°W and 33°N 34°W.

A Vector Averaging Wind Recorder (VAWR) and an Improved Meteorological Recorder (IMET) collected wind speed and wind direction, sea surface temperature, air temperature, short wave radiation, barometric pressure and relative humidity. The IMET also measured precipitation. The moorings were heavily instrumented below the surface with Vector Measuring Current Meters (VMCM) and single point temperature recorders.

Expendable bathythermograph (XBT) data were collected and meteorological observations were made while transiting between mooring locations.

This report describes the work that took place during R/V Oceanus cruise 240 leg 3. It includes a description of the instrumentation that was deployed, information about the XBT data collected and plots of the data as well as a chronology of the cruise events.

Table of Contents

	page
List of Figures	3
List of Tables	4
Section 1: Introduction	5
Section 2: The Mooring Program	6
A. Moorings and Buoys	6
B. Instrumentation	10
C. Underway Measurements	17
Section 3: Chronological Log	18
References	34
Acknowledgements	34
Appendix 1: Personnel	35
Appendix 2: Wind direction comparison tests	36
Appendix 3: XBT Data	39
Appendix 4: Abridged Chronological Log:	75

List of Figures

	page
Figure 1. Mooring Cruise Schedule	5
Figure 2. Oceanus 240 ship track and mooring positions.	7
Figure 3. Discus and Toroid buoys with instrumented tower tops.	8
Figure 4. Instrument Locations on the Subduction 1 Moorings	9
Figure 5. Subduction 1 Northeast Mooring Schematic	19
Figure 6. Subduction 1 Northeast Mooring Acoustic Release Survey	20
Figure 7. Subduction 1 Central Mooring Schematic	22
Figure 8. Subduction 1 Central Mooring Acoustic Release Survey	23
Figure 9. Subduction 1 Southwest Mooring Schematic	25
Figure 10. Subduction 1 Southwest Mooring Acoustic Release Survey	26
Figure 11. Subduction 1 Southeast Mooring Schematic	28
Figure 12. Subduction 1 Southeast Mooring Acoustic Release Survey	29
Figure 13. Subduction 1 Northwest Mooring Schematic	32
Figure 14. Subduction 1 Northwest Mooring Acoustic Release Survey	33
Figure A3-1 a-aa. XBT Profiles in subsets of 10.	40-66
Figure A3-2 a-d. XBT survey area during Oceanus 240 and contour plots	72
Figure A3-3. XBT section locations	73
Figure A3-4. Contoured XBT sections	74

List of Tables

	page
Table 1. Subduction 1 Deployment Information	6
Table 2. Subduction 1 Instrumentation	11
Table 3. VAWR Sensor Specifications	12
Table 4. IMET Sensor Specifications	13
Table 5. Height of Meteorological Sensors Above a Nominal Waterline	14
Table A2-1. VAWR wind direction sensor test results.	37
Table A2-2. IMET wind direction sensor test results	38
Table A3-1. XBT Positions	67

Section 1: Introduction

R/V Oceanus cruise number 240, Leg 3 departed Funchal, Madeira on 17 June 1991 to deploy five surface moorings as part of the Office of Naval Research (ONR) funded ASTEX and Subduction Experiments. This cruise involved both personnel and equipment from the Woods Hole Oceanographic Institution (WHOI) and Scripps Institution of Oceanography (SIO). Appendix 1 lists the members of the scientific party. Table 1 lists the deployment positions and dates for the moorings deployed during the cruise. In addition to the mooring work hourly XBTs and half hourly meteorological observations were taken while transiting between mooring sites.

The mooring deployment schedule for the Subduction experiment is shown in Figure 1. The moored array deployed during R/V Oceanus cruise 240 was the first of three settings for the Subduction experiment and is therefore referred to as Subduction 1. Three eight-month deployments were planned so as to collect a two year data set. Moorings were recovered and redeployed in February and October 1992. The final recovery of the array will take place in June 1993.

This report describes the work that took place during R/V Oceanus cruise number 240. It includes a description of the instrumentation that was deployed, information about the XBT data collected, and a chronology of the cruise events.

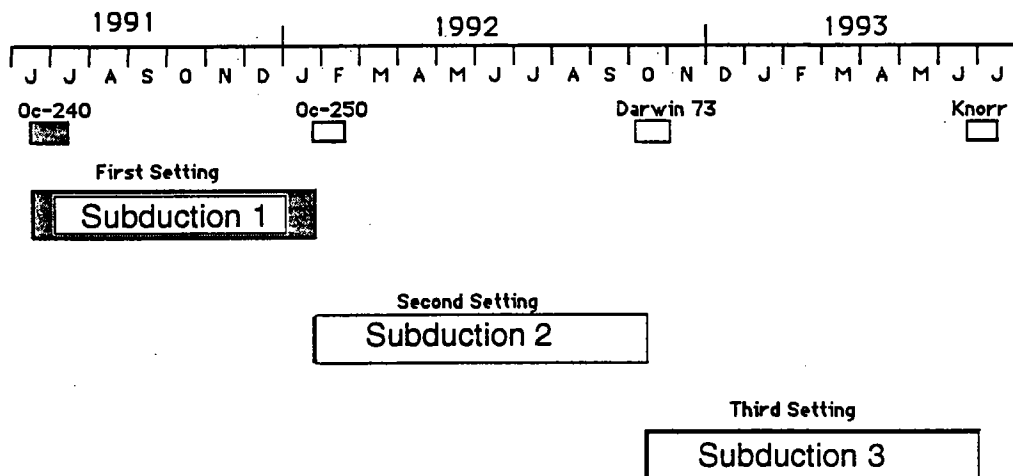

Figure 1. Mooring Cruise Schedule

Table 1. Subduction 1 Deployment Information

Buoy	Mooring #	Deployment Time (UTC)	Position (GPS)
NE	914	18 Jun 1991 1642	33° 00.07'N 21° 59.75'W
C	915	23 Jun 1991 0026	25° 31.90'N 28° 57.17'W
SW	916	25 Jun 1991 1312*	18° 00.03'N 33° 59.96'W
SE	917	29 Jun 1991 0137**	18° 00.13'N 22° 00.00'W
NW	918	3 Jul 1991 1323***	32° 54.61'N 33° 53.50'W

* SW Mooring broke free on 3 November 1991.

** SE Mooring broke free on 10 October 1991.

*** NW Mooring broke free on 3 August 1991.

Section 2: The Mooring Program

A. Moorings and Buoys

Two of the five surface moorings deployed in conjunction with the Subduction experiment were prepared by WHOI. These moorings had a 10' diameter discus buoy as their primary flotation at the surface. The WHOI moorings were deployed at the Northeast (NE) and Central (C) sites of the array. The other three moorings were prepared by SIO and had 7'6" diameter toroid shaped buoys for their primary flotation. The SIO moorings occupied the Southeast (SE), Southwest (SW) and Northwest (NW) sites of the array. Figure 3 shows a line drawing of the discus and toroid buoys with their instrumented tower tops. Figure 4 schematically shows all five moorings and the location of the subsurface instrumentation.

Meteorological instrumentation was mounted to both the discus and toroid buoys. A two part aluminum tower was attached to both buoy types. The top half, which had all the meteorological sensors, marine lantern and satellite antennae is the same for both buoy types so as to minimize the differences between buoys and to facilitate assembly. The lower half was specific to the buoy type and acts as an interface between the buoy hull and the tower top. The tower tops were separate assemblies so that they could easily be replaced with new units containing freshly calibrated sensors when the moorings were recovered and redeployed in February and October 1992.

Figure 2. Oceanus 240 ship track and mooring positions

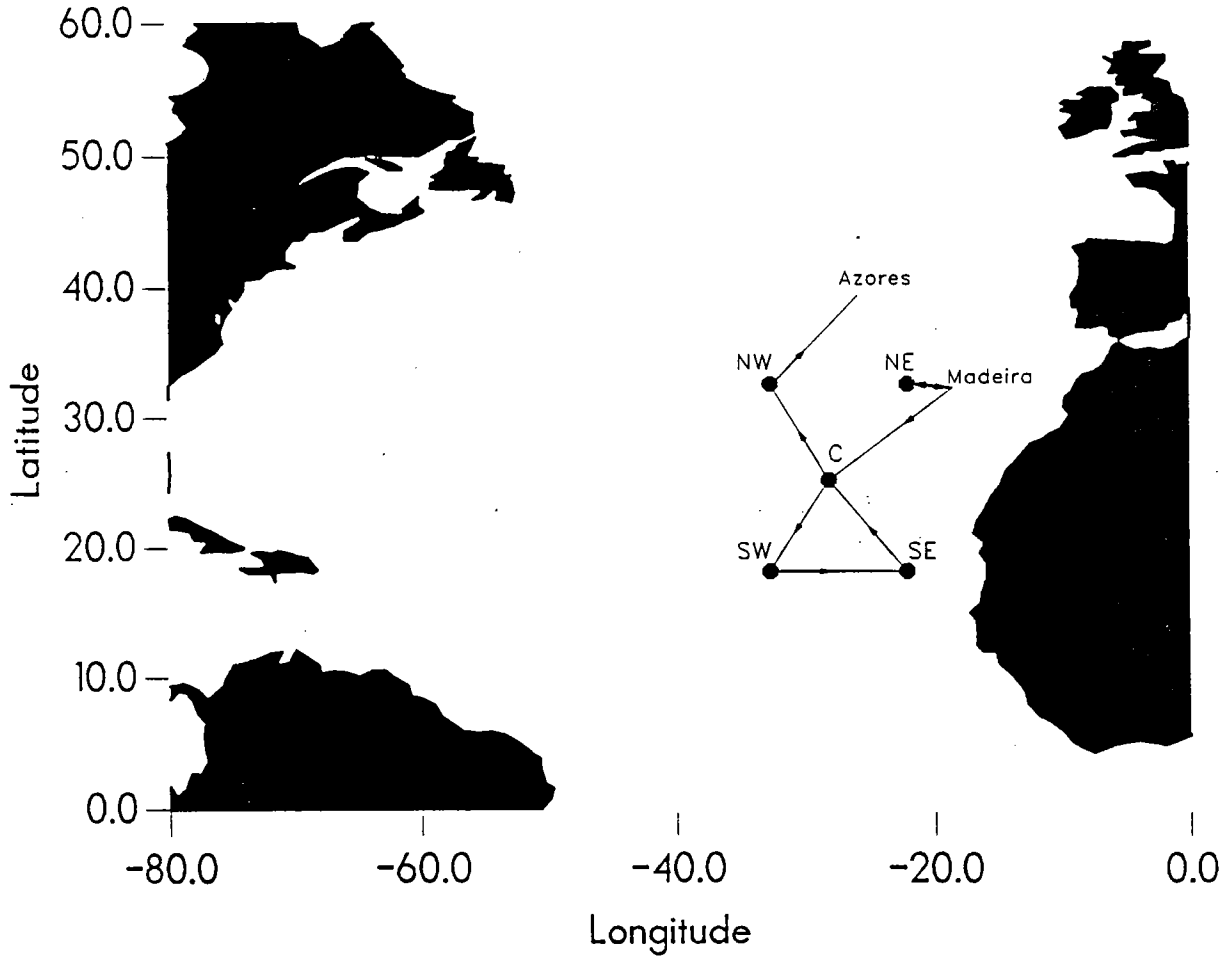

Figure 3. Disc and toroid buoys with instrumented tower tops.

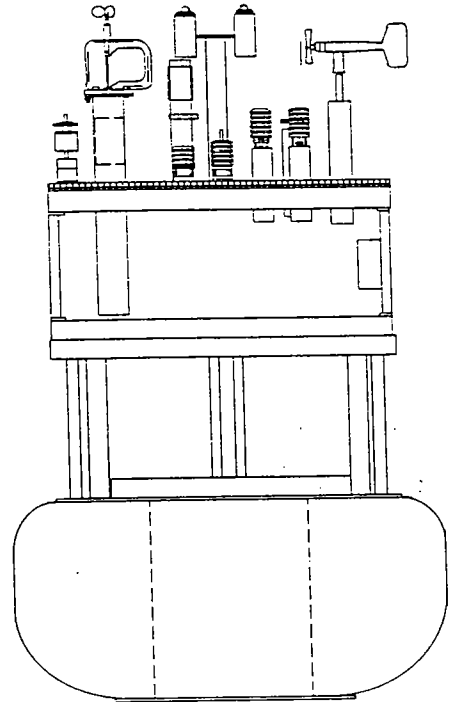
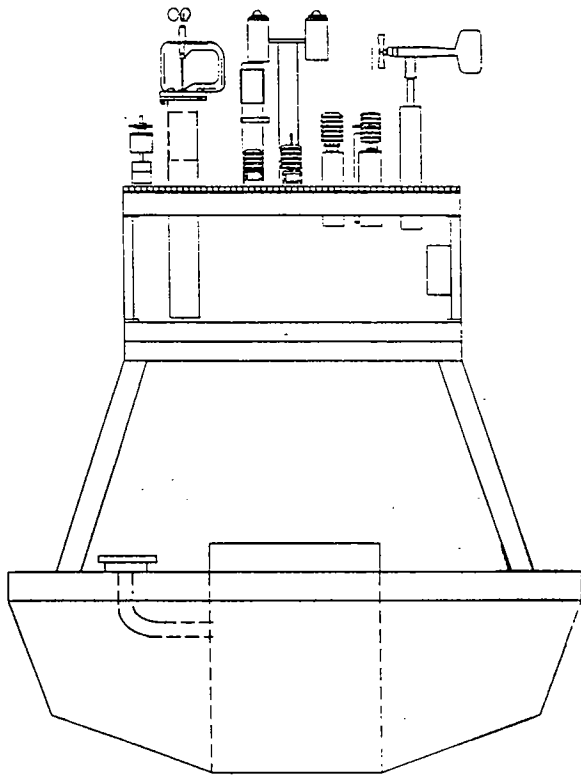
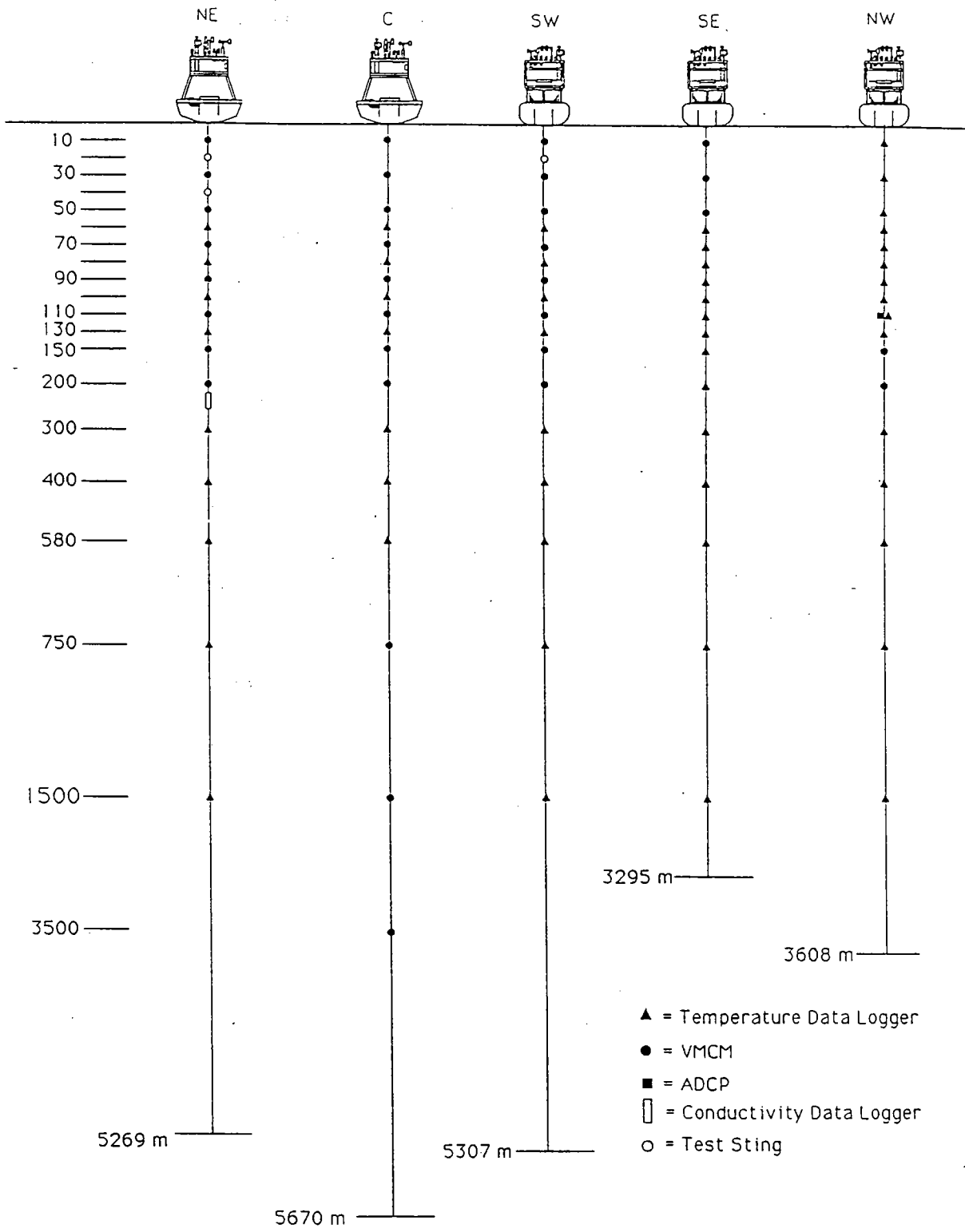

Figure 4. Instrument locations on the Subduction 1 moorings.



B. Instrumentation

A total of 97 recording instruments were deployed on the five Subduction surface moorings. There were 9 meteorological packages, 32 current meters, 53 temperature data loggers, one acoustic Doppler profiler, one conductivity recording instrument and one tension recorder. The specific instrumentation deployed during this cruise is shown in Table 2 .

Meteorological Instrumentation

Four of the five buoys (NE, C, SE and SW) were outfitted with two separate meteorological instruments. One system was a Vector Averaging Wind Recorder (VAWR) which recorded measurements of wind speed and direction, air temperature, relative humidity, barometric pressure, sea surface temperature, short wave radiation, and long wave radiation. Additional information about the VAWR can be found in Trask et al., 1989. The other meteorological package was an IMET (Improved METeorological measurements) system which made measurements of the same variables as the VAWR plus precipitation. Tables 3 and 4 provide details about the individual sensors on the VAWR and IMET systems respectively. Both the VAWR and IMET systems individually recorded all data internally as well as telemetered their data via Argos . The VAWR stored its data on cassette tape every 15 minutes and the IMET system recorded on optical disk every minute. The Northwest toroid was outfitted with a single VAWR.

For both the discus and toroid buoys the VAWR sensors (except sea temperature), and electronics with battery pack were attached to the tower top. The sea surface temperature sensors for both the VAWR and IMET systems were attached to the buoy bridle approximately 1 meter below the surface. The IMET sensors on the discus and toroid buoys were configured the same and mounted on the tower top. Sensor heights with respect to the waterline are listed in table 5. In the case the discus buoys the IMET electronics and rechargeable batteries were housed in the discus buoy water tight instrument well. The toroids however had no instrument well and the electronics were fitted in a fiberglass weatherproof enclosure which was secured to the deck of the toroid. The batteries used to power the IMET system on the toroids were Deep Sea Power and Light (San Diego, CA) underwater batteries. These batteries were housed in a stainless frame that was clamped to the inside of the buoy bridle. This configuration provided additional stability for the toroid buoy.

Prior to deployment the air and sea temperature sensors as well as the relative humidity sensors were calibrated at WHOI. The calibrations of the barometric pressure sensors were checked and if found out of specification were returned to the manufacturer for recalibration. The short wave and long wave radiation sensors were calibrated by the manufacturer. The wind direction sensor readings were compared with a known bearing to a fixed target. Details of the direction comparison tests can be found in Appendix 2.

Current Meters

A total of 32 Vector Measuring Current Meters (VMCM) provided by both WHOI and SIO were deployed on the five Subduction surface moorings. The 20 WHOI VMCMs were a modified version of the EG&G Sea Link instrument whereas the 12 SIO VMCMs were built by Scripps personnel. The sampling interval for the WHOI VMCMs was 7.5 minutes and for the SIO VMCMs it was 15 minutes.

The WHOI VMCMs incorporated several changes to the standard EG&G Sea Link product. These included different propeller bearings, a different plastic for the propeller

Table 2. Subduction 1 Instrumentation

Depth	NE	C	SW	SE	NW
VAWR IMET	V-704WR	V-722WR	V-720WR	V-721WR	V-121WR
10	VM-041	VM-035	SVM-04	SVM-12	S-3285
20	TEST STING1		TEST STING2		
30	VM-021	VM-033	SVM-07	VM-007	S-3315
40	TEST STING3				
50	VM-039	VM-024	SVM-06	SVM-16	S-3294
60	W-3274	W-3309	S-3314	W-3297	W-3262
70	VM-032	VM-012	SVM-22	S-3282	S-3313
80	W-3265	W-3308	W-3279	S-3270	S-3260
90	VM-022	VM-038	SVM-02	S-3298	S-3261
100	W-3288	W-3296	W-3303	S-3284	W-3258
110	VM-030	VM-009	SVM-05	S-2425	ADCP
130	W-3269	W-3280	S-2427	S-2432	S-3277 S-2434
150	VM-028	VM-037	SVM-20	S-2418	SVM-11
200	VM-018	VM-016	SVM-13	S-2424	SVM-10
206	COND				
300	W-3300	W-3289	S-2435	S-2433	S-2421
400	W-3305	W-3283	S-2437	S-2422	S-2431
580	W-3268	W-3271	W-3341	W-3290	W-3272
750	W-3286	VM-015	S-2436	S-2426	S-2420
1500 3490 3500	W-3293	VM-034 TENS 1029 VM-011	W-3287	W-3259	W-3273

W-# = WHOI Brancker Temperature Recorder
S-# = SIO Brancker Temperature Recorder
VM-# = WHOI Vector Measuring Current Meter
SVM-# = SIO Vector Measuring Current Meter

Table 3. VAWR Sensor Specifications

Parameter	Sensor	Range	Comments
Wind Speed	Gill 3-cup Anemometer R.M. Young Model 12170C 100 cm/rev	0.2-50 m/s	Vector-averaging
Wind Direction	Integral Vane w/ Vane follower WHOI / EG&G	0-360°	Vector-averaging
Short wave Radiation	Pyranometer Eppley Model: 8-48	0-1400 watts/m ²	Average system
Long wave Radiation	Pyrgeometer Model: PIR	0-700 watts/m ²	Average system
Relative Humidity	Variable Dielectric Conductor Vaisala Humicap	0-100%	3.5 sec sample
Barometric Pressure	Quartz Crystal Digiquartz Paroscientific Model: 215	0-1034 mb	2.5 sec sample (Burst taken midway through avg. period)
Sea Temperature	Thermistor Thermometrics 4K @ 25° C	-5 to +30°C	1/2 time average Measured during first half of avg. period.
Air Temperature	Thermistor Yellow Springs #44034 5K @ 25°C	-10 to +35° C	1/2 time average Measured during 2nd half of avg. period.

Table 4. IMET Sensor Specifications

Parameter	Sensor	Range	Comments
Wind Speed and Wind Direction	R.M. Young Model 5103 w/9 bit Gray Code encoder and KVH Industries Model MC202 compass	0-60 m/sec	Vector-averaging
Short wave Radiation	Eppley Precision Spectral Pyranometer (PSP)	0-1400 watts/m ²	1 minute average
Long wave Radiation	Eppley Precision Infrared Pyrgeometer (PIR)	0-600 watts/m ²	1 minute average
Relative Humidity	Rotronic MP-100F	0-100%	1 minute average
Barometric Pressure	AIR Inc Model: DB-1A	850-1050 mb	1 minute average
Sea Temperature	Platinum Resistance Thermometer	-5° to +45° C	1 minute average
Air Temperature	Platinum Resistance Thermometer	-40° to +45° C	1 minute average
Precipitation	R.M. Young Model: 50201 Siphon Rain Gauge	0-50 mm	

Table 5. Height of Meteorological Sensors above a Nominal Waterline.

	Discus*	Toroid**
VAWR		
Air Temperature†	2.73	2.39
Relative Humidity†	2.74	2.40
Barometric Pressure	2.79	2.45
Short wave Radiation	3.45	3.11
Long wave Radiation	3.45	3.11
Wind Speed	3.40	3.06
Wind Direction	3.12	2.78
IMET		
Air Temperature†	2.79	2.45
Relative Humidity†	2.79	2.45
Barometric Pressure	2.76	2.41
Short wave Radiation	3.45	3.11
Long wave Radiation	3.45	3.11
Wind Speed and Direction	3.17	2.83
Precipitation	3.15	2.81

* Waterline approximately .41 m from buoy deck

** Waterline approximately .43m from buoy deck

† Measurement to midpoint of shield

Units = Meters above the waterline

blades and a redesign of the instrument cage. The cage redesign is described in Trask *et al.* (1989) as is some historical information on propeller bearings and blade materials.

For the first deployment of the Subduction experiment the WHOI VMCMs in the upper 100 meters were outfitted with cages that had 3/4" cage rods. The deeper instruments had cages with 1/2" cage rods. All cages had a single cross brace to support the sting between the two sets of propellers.

VMCM Bearings

An alternative propeller bearing chosen for use in the Subduction experiment was an all silicon nitride ball bearing (SiNi balls and races with a Duroid ball retainer) available from Miniature Precision Bearing (MPB), of Keene, New Hampshire as part number J0001-809. This was selected over the typical stainless steel bearing based on previous test results, actual deployments and the fact that the 8 month Subduction deployment would be 30% longer than most previous deployments.

The 3/8" diameter propeller shaft ball bearings typically used on VMCMs had stainless steel races and balls. Both type 316 and 440 stainless steel bearings had been used with variable results. The type 316 bearings offered greater corrosion resistance but were a softer material and showed excessive wear when used on near surface VMCMs. The type 440 stainless bearings were harder and could tolerate the near surface conditions but were less resistive to corrosion than were the type 316 bearings. The upper instruments required a bearing material with greater wear resistance due to the considerable relative motion they experienced introduced not only by the ocean currents and orbital wave velocities but also by the motion of the buoy as it tended to slide down the slope of the waves seeking the trough. Corrosion was still a factor but to a lesser degree. The deeper instruments experienced less wave action and did not experience as much buoy motion as did the near surface instruments. These bearings were not being flushed as readily as those near the surface and corrosion by products could build up in the bearing and cause it to bind. A bearing material more resistant to corrosion was therefore needed in the deeper environment. In the past the Upper Ocean Processes Group (UOP) group had outfitted the upper VMCMs with the type 440 stainless bearings and the deeper instruments have had type 316 stainless bearings. This configuration of bearings seemed to just survive a 5 to 6 month deployment however the individual surface mooring deployments for the Subduction experiment were planned for 8 months so an alternative bearing material was needed.

Previous test results indicated that silicone nitride bearings might be a promising alternative. The first tests of silicon nitride bearings were conducted in an accelerated wear test fixture. During those tests it was found that the SiNi balls displayed considerably less wear than did their stainless steel counterparts for the same operating period. One of the original bearings with SiNi balls had been used on three separate surface mooring deployments for a total of 19 months. (Since the spin characteristics of these bearings continued to be satisfactory they were deployed for a fourth time on one of the Subduction moorings). VMCMs with MPB SiNi bearings had been deployed on several different surface moorings but none had the opportunity to be reused. The longest deployment being 17 months. This however was not a typical deployment since the mooring parted after 66 days on station. The current meters with the SiNi bearings fell to the bottom (2845 m) and remained there for 15 months with little to no propeller motion. Upon recovery of these instruments the inspection of their bearings showed no detectable wear in either the balls or the races. The longest deployment in which the MPB SiNi bearings had continual use was off Bermuda for 9 months. Following recovery these bearings were inspected and appeared to be smooth and shiny with no visual wear. The races and balls were measured and there were no differences between similar parts. The Duroid ball retainer also showed little to no wear.

VMCM Propellers

The propellers for VMCMs which are commercially available from EG&G Ocean Products are manufactured by injection molding Delrin 577, a glass filled, ultraviolet stabilized acetal plastic. Individual blades of these propellers frequently returned from a deployment broken close to where the blade is dovetailed into the hub. Some propellers returned completely intact, while others were missing one or several blades and still others had no blades at all. Given the unpredictable nature of the problem a UOP group policy was established to not reuse the Delrin 577 propellers. New propellers were used every time the instrument was deployed.

The failure mode was first thought to be due to fatigue. It was hypothesized that the blades were constantly being flexed a finite amount until they failed. To test this hypothesis a fixture was set up in the laboratory to flex the propeller blade at an accelerated rate until it failed. The signature of the break caused by fatigue in the laboratory did not, however, resemble that which was always seen on the recovered propeller hubs. The signature of the at-sea break more closely resembled the type of break that occurs when the blade is quickly broken by hand when sharply bending it toward the front of the hub. Given the similarity of the breaks it was felt that the failure may be due to a more rapid process such as impact possibly by fish rather than fatigue.

Blade breakage however had not been a problem for SIO VMCM propellers. The SIO blades were reused many times without any evidence of a breakage problem. The SIO blades were machined rather than injection molded and were made from Delrin 500 which is not glass reinforced. A sample of the SIO blades along with both used and new Delrin 577 blades as well as an unreinforced Delrin blade were tested by the Comtex Development Corporation formerly of Bridgewater, MA. Three mechanical tests namely a flexure strength test (ASTM D790) and notched and unnotched IZOD Impact tests (ASTM D256) were completed on each blade type to assess the toughness and notch sensitivity of the materials.

Test results from the new and used Delrin 577 indicate that there was no detectable degradation in properties either with exposure to sea water or due to the stresses and fatigue of operation. In comparing the glass reinforced material with that which was not reinforced it was seen that the reinforcing fibers increased the flexure modulus by 45% but decreased the strength by 6.5%. Both of the factors are unfavorable because the reinforced blade cannot bend nearly as much before it reaches its failure stress. This indicates that the unreinforced material will bend farther and absorb more energy before cracking. This conclusion was confirmed by the IZOD impact tests. The notched impact strength of the unreinforced blade was 77% higher than the notched reinforced blade. In addition the unreinforced material had unnotched impact strengths 3 times greater than those for the reinforced blades.

Based on these results a decision was made to change to a unreinforced Delrin for the VMCM propeller blades. The material chosen was unpigmented Delrin 100 ST which is impact modified. The 100 ST has an Izod impact strength nearly 20 times greater than the Delrin 577 material. Since the flexural modulus of the 100ST is 180 kpsi vs 730 kpsi for the 577 material the 100 ST blades are considerably more flexible. Concern that the propeller blade might flex to the point of interfering with the VMCM sting led to several flow tests conducted by SIO personnel in their hydraulics laboratory stratified flow channel. The Delrin 100 ST propellers were checked at 5, 53, 76, 85, 91, 97, 107, 122, and 125 cm/sec flow. The sting was then rotated 180 degrees and tested at 125 cm/sec thus checking the deflection of the propellers for forward and aft currents. Throughout these tests there was no visible deflection of the propellers blades and therefore no interference with the sting. The clearance between the blades and sting remained constant at approximately .4" for the entire range of flows.

VMCM Bearing and Propeller Test Stings

In order to continue to gain experience with various bearing materials several test stings were deployed. The test sting consisted of a standard VMCM sting with two orthogonal hubs.

Since there are no electronics wired to the sting the pressure case was replaced by a short PVC housing at the base of the sting to provide a watertight seal and as a means of attachment to the cage.

Three test stings were deployed on the Subduction 1 moorings. Test sting number one (TS-1) was deployed at 20 meters depth on the Northeast discus mooring. Both hubs of the sting were fitted with previously used MPB silicone nitride bearings from the first Marine Light in the Mixed Layer deployment in 1989 (MLML-89). The 3/8" bearings (i.e. they have a .875" outside diameter (O.D.) and .375" (3/8") bore) were glued to the 3/8" diameter type 316 stainless steel propeller shafts using Loctite 271 and Primer T. Type 316 stainless steel C-rings were used on the shafts. The upper hub had propellers injection molded with Delrin 577 and the lower hub had WHOI assembled propellers with Delrin 100 blades and Delrin 577 propeller hubs.

Also on the Northeast discus mooring but at 40 meters depth was another test sting (TS-3). Both hubs on this test sting had used 3/8" bore bearings that consisted of silicone nitride balls and tungsten carbide races. These bearings were used in instruments that were deployed in three previous experiments. They were at 50 meters depth for 5 months during the Frontal Air Sea Interaction Experiment (FASINEX), followed by 8 months at 30 meters on a pilot mooring for the Subduction experiment called the PreSubduction Experiment and then at 15 meters depth for 6 months as part of the second deployment of the Engineering Surface Oceanographic Mooring (ESOM II) for a total of 19 months of operation at sea. The propeller shafts were 3/8" in diameter and were type 316 stainless steel. Type 316 stainless steel C-rings were used on both shafts. The propellers on the upper hub had Delrin 100ST blades with Delrin 577 hubs and the lower hub had propellers with Delrin 577 blades and hubs.

Another test sting, labeled TS-2 was deployed on the Southeast toroid mooring at 20 meters depth. The upper hub of this test sting was outfitted with a pair of used MPB silicon nitride bearings (part no. J0001-809) previously used in the MLML-89 deployment described earlier. The lower hub had a pair of new 440 stainless steel bearings (MPB part no. SR6MCKHH 5). Both upper and lower hubs had 3/8" diameter type 316 stainless propeller shafts with 3/8" C-rings of unknown type stainless. The upper hub had Delrin 100ST propeller blades and a Delrin 577 propeller hub. The propellers on the lower hub had Delrin 577 blades and hubs.

Temperature Loggers

A total of 53 temperature data loggers manufactured by Richard Brancker Research Ltd. were provided by both WHOI and SIO for the 5 Subduction moorings. The location of the loggers are shown in figure 4 and table 2. The loggers provided by WHOI were attached to the mooring line using a hinge type clamp that was tightened around the wire. The SIO clamping arrangement consisted of two 2-piece monel blocks which had been machined to accept the mooring wire. The two pieces were clamped around the wire with .25" hardware.

Several different Brancker temperature recorder models were deployed. The SIO 2000 series instruments which had SIO fabricated pressure cases and endcaps sampled at 30 minute intervals. The WHOI and SIO 3000 series instruments sampled at 15 minute intervals.

C. Underway Measurements

Expendable Bathythermographs (XBT)

Two hundred and sixty-eight XBTs were deployed during OC-240. The T-7 probes were purchased from Sippican Inc. of Marion, MA. XBT data was logged on a NEC APC IV which had a Spartan of Canada data acquisition microprocessor card installed. The digital data was simultaneously logged in memory and plotted on the screen.

Hourly XBTs were taken on the hour while the ship was underway. XBTs were suspended when the ship was within 10 miles of a surface mooring. XBT positions and overplots of the XBT data as well as several horizontal contour plots of temperature at various depths and vertical sections of temperature are included in Appendix 3.

Meteorological Measurements

In addition to collecting hourly XBT data, meteorological observations of air temperature, relative humidity, relative wind speed and direction, (along with the ship's speed and direction), barometric pressure and sea surface (bucket) temperature were recorded every 30 minutes on the hour and half hour.

Section 3: Cruise Chronology

Leg 3 of Oceanus cruise number 240 departed Funchal, Madeira on June 17th, 1991 at 0714 UTC. The purpose of Leg 3 was to deploy a total of five surface moorings for the ONR funded ASTEX and Subduction Experiments. The nominal mooring locations are shown in Figure 2.

Northeast Mooring

The first mooring to be deployed was the Northeast mooring shown schematically in figure 5. Upon arrival at the site a depth survey was conducted. The bottom was found to be relatively flat with the mooring site having a corrected water depth of 5264 meters. Throughout the depth survey, mooring deployment, and subsequent acoustic release/anchor survey GPS was used during all navigation.

Following the depth survey two acoustic releases were wire tested down to 1000 meters using the trawl winch. The CTD/hydro winch was not used because the wire was removed to lessen the ship's load which was at its maximum when the ship left Madeira. No problems were encountered during the release tests.

The mooring deployment began 7 nautical miles downwind (southeast) of the target. The near-surface instrumentation were deployed first followed by the surface buoy and the remainder of the mooring. Careful attention was paid to the target site so as to get the anchor as close to it as possible. The anchor was deployed at 1642 UTC on 19 June 1991. Following the deployment an acoustic release/anchor survey (figure 6) was conducted. **Based on the anchor survey the GPS anchor position for the Northeast Subduction mooring (WHOI mooring number 914) was 33°00.07'N, 21°59.75'W.**

During the anchor survey the ship was positioned 1/4 mile downwind of the surface buoy and measurements of sea surface temperature, air temperature, relative humidity, barometric pressure, wind speed and direction were made every 5 minutes for 30 minutes. The ship's position at the start of the meteorological observations was 32°59.362'N, 22°00.151'W.

Following the anchor survey the ship returned to Madeira to load equipment that could not fit during the first part of the cruise. One toroid surface buoy and three anchors with flip plates and seven wire baskets were loaded in Madeira. During the loading of the wire baskets the shoreside crane lost control of the load and dropped it between the ship and the quay. In so doing it damaged the VAWR and one solar panel on the Southeast toroid surface buoy. The wind speed and direction head on the VAWR and solar panel were replaced with spares. Upon completion of loading and fueling in Madeira the ship departed at 2000 on 19 June 1991 enroute to the Central mooring site.

Figure 5. Subduction 1 Northeast Mooring Schematic

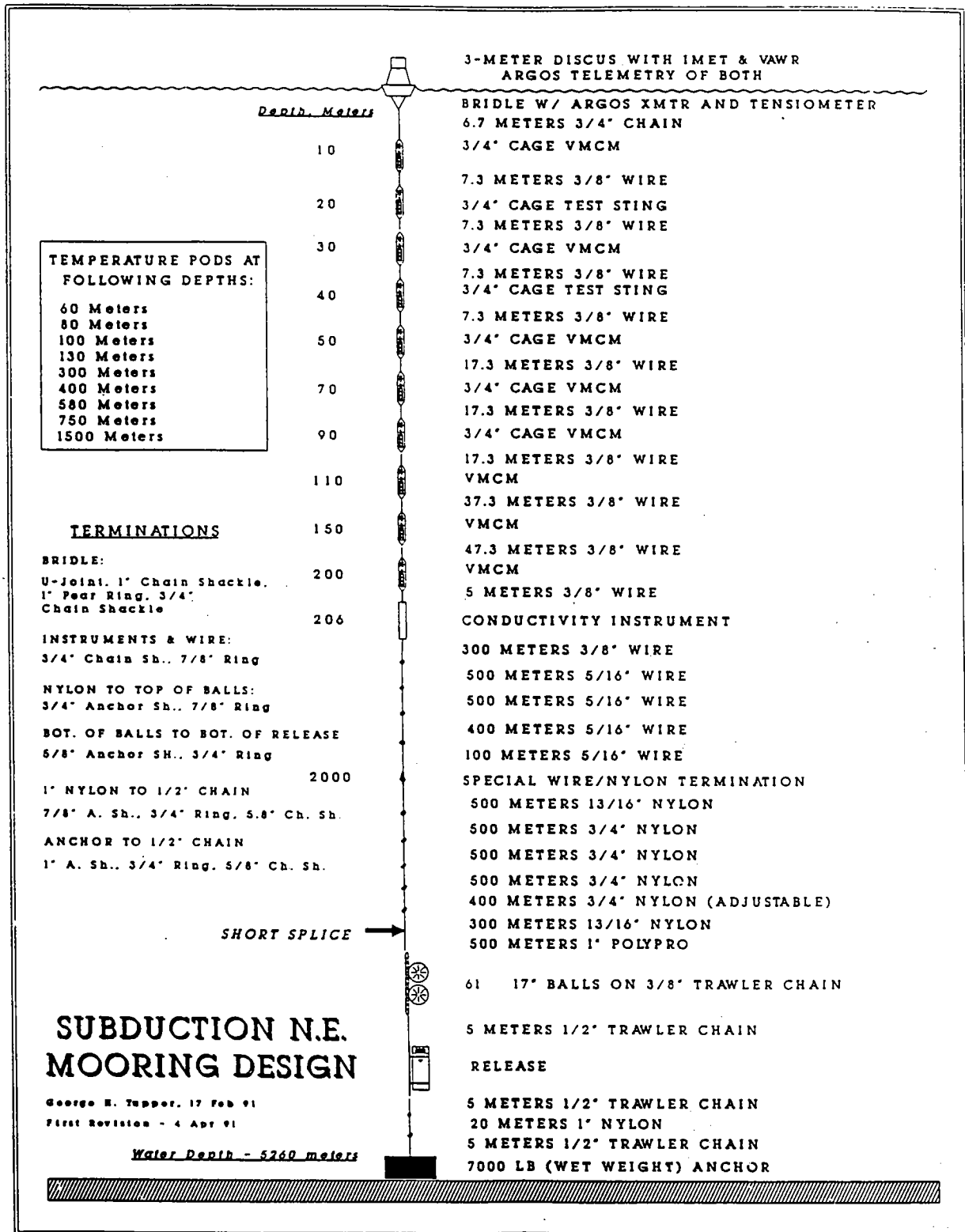
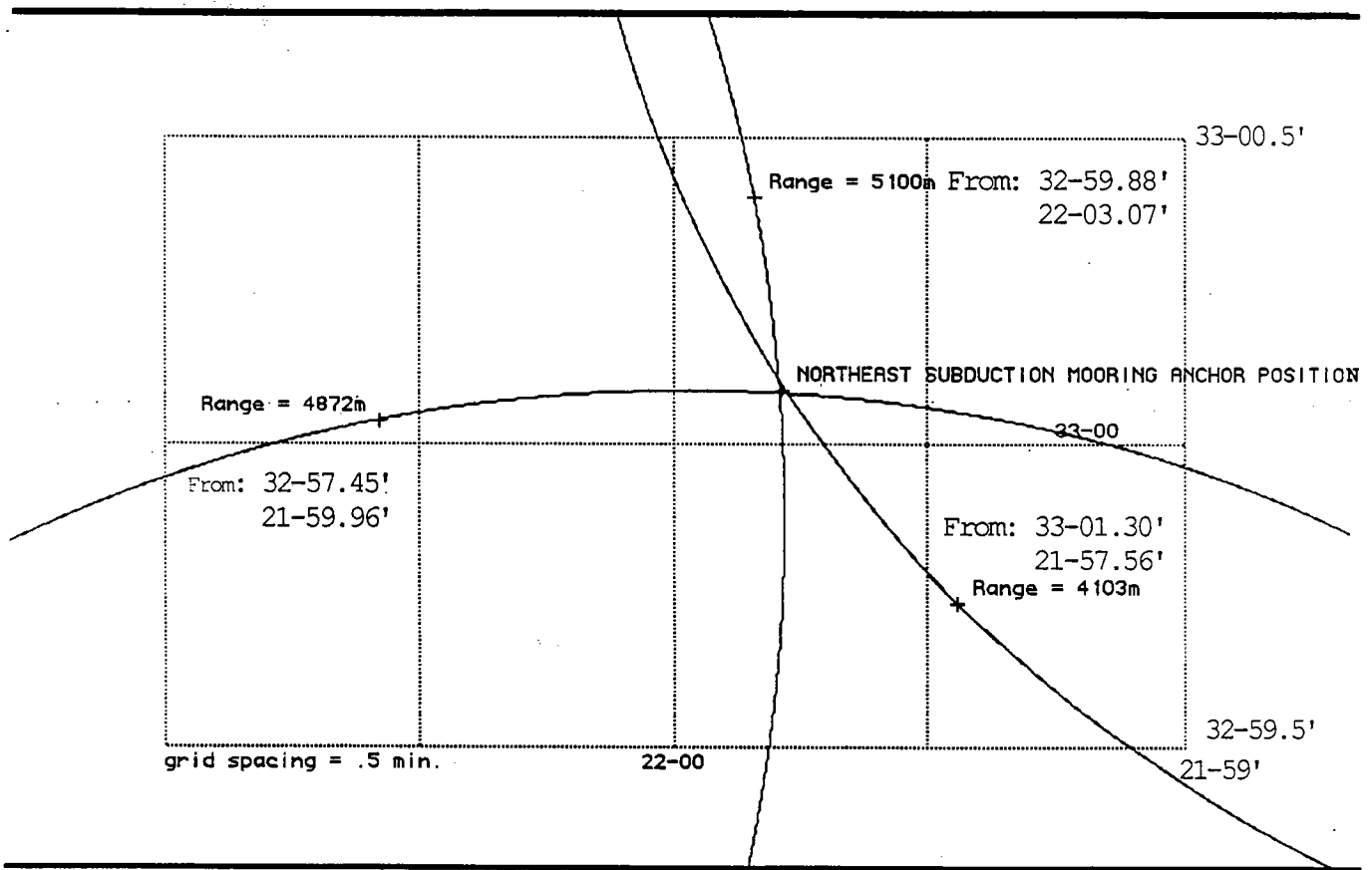

Figure 6. Subduction 1 Northeast Acoustic Release Survey



While enroute to the Central mooring site and throughout the remainder of the cruise (except as noted below) hourly XBTs were taken starting at position 31°17.67'N, 19°16.37'W.

Central Mooring

The second mooring to be deployed was the Central Subduction mooring shown schematically in figure 7. This mooring was unique in that it had two large clusters of glass ball flotation separated by 2000 meters of wire rope. It was a combination of a surface mooring and a taught subsurface mooring.

Deep current measurements from typical WHOI surface moorings have been difficult to make because the mooring inclination at depth can exceed the recommended 15 degrees needed for accurate current measurements. In addition the compliance of the nylon below 2000 meters results in uncertainty as to the depth of the measurements. The Central mooring design was a new design intended to keep the 3500 meter deep VMCM a known distance off the bottom and at an acceptable angle of inclination (<15 degrees).

The R/V Oceanus arrived at the Central Subduction mooring site at 1030 UTC on June 22, 1991. The depth survey was started upon arrival. The original proposed mooring site (25°30'N, 29°W) had an irregular sloping bottom and it was decided to move the site to the northeast about 3 nautical miles where the bottom was flat and uniform. Following the depth survey one WHOI acoustic release and one SIO release were wire tested down to 1000 meters.

Upon completion of the acoustic release wire tests the Oceanus moved to a position 7 miles downwind (southwest) of the new mooring site in preparation for starting the mooring deployment. The buoy and upper instrumentation were deployed without incident starting at 1445 UTC. The deployment continued through to the wire-to-nylon shot which had all been pre-wound on the winch. At this point the mooring was stopped off and towed while the remaining shots were wound. Once the remainder of the mooring was on the winch, payout was resumed. The ship's speed over the ground during the deployment of the first half of the mooring (up to the first cluster of glass balls) was approximately 1 knot. After the glass balls were deployed the ship's speed was slowed to between .5 and .7 knots in anticipation of the increased drag due to the glass balls. The anchor was deployed at 0027 UTC on June 23, 1991. Following the deployment an anchor survey (figure 8) was conducted. **The GPS anchor position for the Central mooring (WHOI mooring number 915) was 25°31.90N, 28°57.17W.** The water depth at the site was 5670 meters.

Following the deployment of the Central mooring, water samples were collected for Jim Ledwell (WHOI). Since there was no hydro wire on board the ship, a reel of 1/4" kevlar was wound on the TSE mooring winch. Nine depths had previously been marked on the kevlar where Niskin bottles were to be placed. The Kevlar was deployed with a weight off the stern and Niskin bottles were attached at the appropriate depths (50, 100, 150, 200, 250, 300, 350, 400 and 450 meters). The Niskin bottles were tripped at 0135 UTC on 23 June 1991 at position 25°32.817'N, 28°55.498'W. The surface wire angle at the time the samples were collected was measured to be approximately 30 degrees.

Prior to leaving the Central mooring site the Oceanus was positioned 1/4 mile downwind of the surface buoy. Shipboard meteorological observations were logged every 5 minutes for

Figure 8. Subduction 1 Central Mooring Acoustic Release Survey

Central Mooring Release Survey

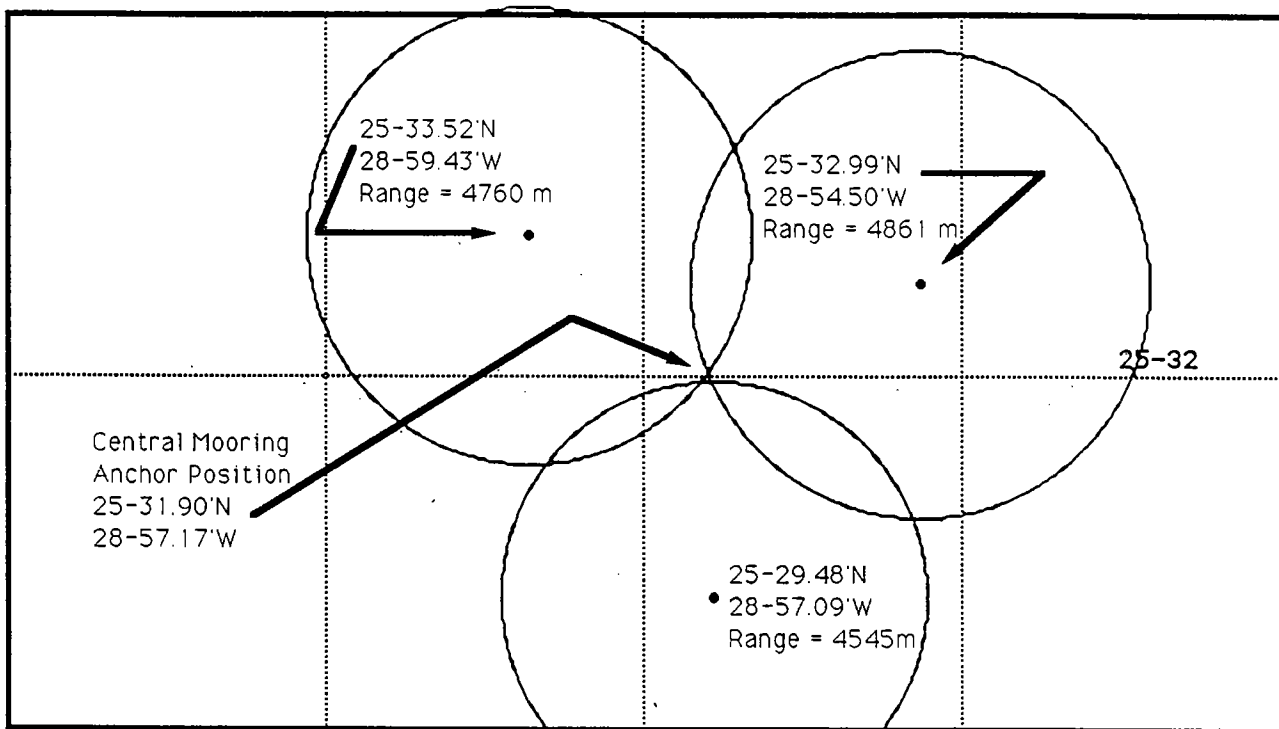

30 minutes using the same procedures as were used for the Northeast mooring. These intensive meteorological observations were made at 25°31.53'N, 28°57.91'W.

Southwest Mooring

The R/V Oceanus arrived at the Southwest mooring site at 2330 UTC on 24 June 1991. A depth survey of the site was begun immediately. The original mooring site and the area around it was found to be relatively flat with a corrected water depth of 5307 meters. Following the depth survey an acoustic release wire test was conducted down to 1000 meters to test two SIO releases. Both releases checked out without any problems.

The ship was then positioned 6 miles downwind of the proposed mooring site and preparations were made for the deployment of the Southwest mooring. A schematic of the mooring is shown in figure 9. The procedure used to deploy the SIO toroid mooring was nearly identical to that used to deploy the discus moorings. The first three current meters were placed in the water first over the starboard side followed by the toroid buoy. Deployment of the upper instruments began at 0437 UTC. The buoy appeared to ride well even with the relatively light load under it early on in the deployment. Care was taken to deploy the upper shots of wire slowly while keeping the ship's speed at about .5 knots. Once more wire and instrumentation were hanging below the buoy the payout rate was increased and the ship's speed was increased to between .5 and 1 knot.. Payout was stopped once and the mooring was towed while the remaining mooring components were wound onto the winch. Payout was resumed and the anchor was deployed at 1312 UTC on 25 June 1991.

Immediately following the anchor deployment the ship was positioned such that it could observe the surface buoy as the anchor went to the bottom. The buoy was seen plowing through the water at about 3 - 4 knots inclined at an angle of approximately 30°. As more time elapsed the buoy appeared to get deeper into the water. This continued until the entire buoy including the tower and instrumentation were completely submerged. The buoy remained submerged for about 1-1.5 minutes. The buoy then reappeared on the surface and remained there. The instrumentation on the buoy was intact however Argos telemetry from the IMET package could not be detected. Argos telemetry from the VAWR could still be received. The water line was approximately 17" from the top of the buoy hull with occasional wash over the entire hull.

An acoustic release/ anchor survey was conducted (figure 10). Based on the results of this survey the **GPS anchor position for the Southwest Subduction mooring (WHOI Mooring number 916) was 18°00.03'N, 33°59.96'W.** Comparing the anchor drop position with its final surveyed position indicates that the anchor fell back approximately 167 meters or 3.1% of the water depth.

A decision was made to remain by the buoy overnight and monitor the Argos telemetry from the VAWR. The marine lantern continued to function. Meteorological observations made from the ship were compared with the Argos telemetry from the VAWR which appeared to produce reasonable data throughout the night. By morning a decision was made to leave the Southwest mooring as deployed and steam for the Southeast mooring site.

The problems encountered at the Southwest mooring were discussed with personnel at both SIO and WHOI. The consensus was that the buoy traveling on top of the water could not keep up with the anchor descent rate and if the anchor could be slowed sufficiently then there was a chance that the buoy would remain afloat. To slow the anchor's rate of descent its drag needed to be increased. Despite the limited resources available on board ship a drag element was assembled. Four empty wire reels were laid on their cheeks and aircraft strapped together. A fifth reel was placed on top and through bolted to the bottom reels. This collection of reels were then captured in a cargo net. A four part bridle was then woven through the cargo net and attached to a sling link. Back of the envelope calculations indicated that this conglomeration of reels would provide 3000 to

Figure 10. Subduction 1 Southwest Mooring Acoustic Release Survey

Southwest Mooring Release Survey

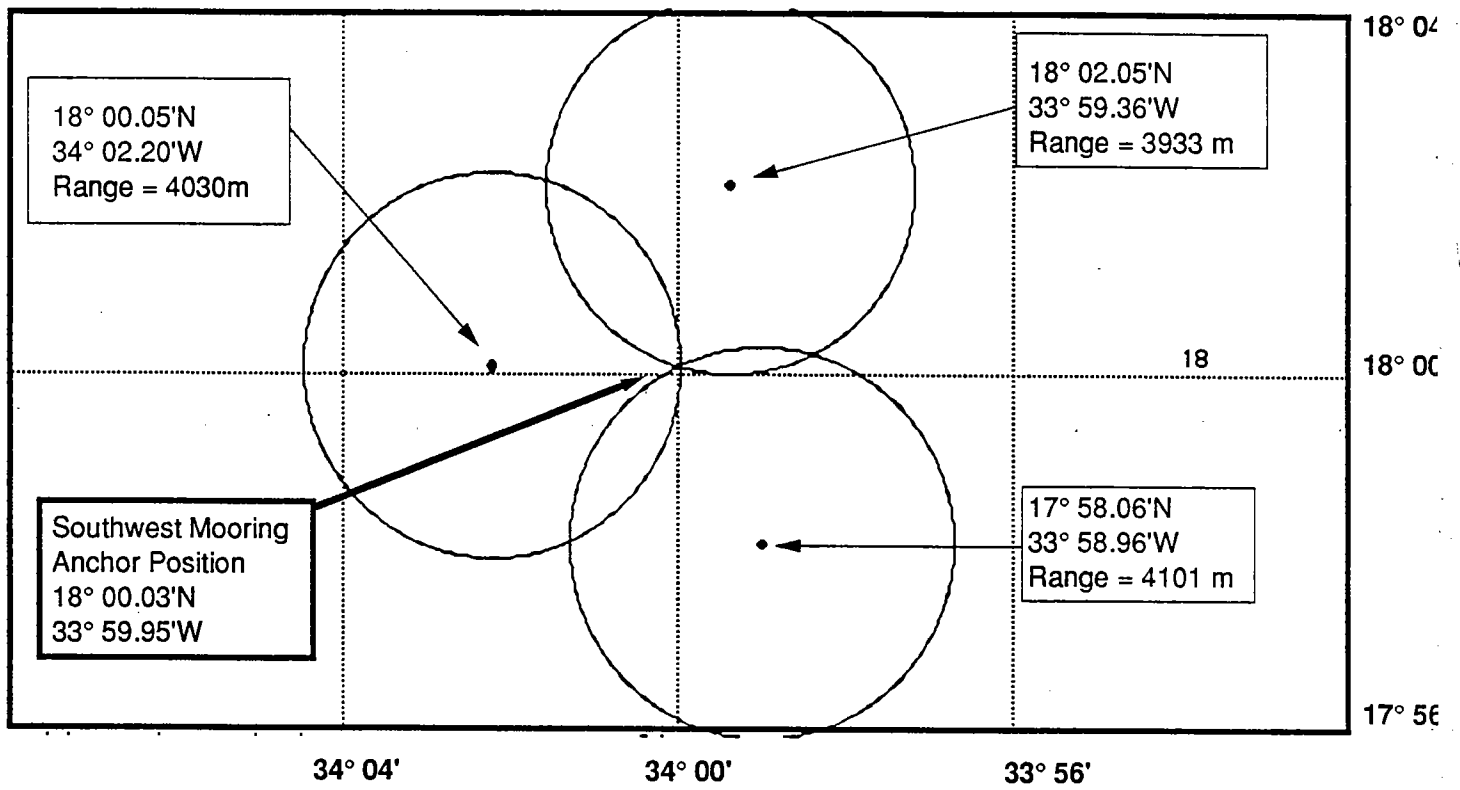

5000 pounds of drag slowing the anchor by 55 to 65%. This drag element was to be used on the next toroid mooring.

Southeast Mooring

The R/V Oceanus arrived at the Southeast mooring site at 1835 UTC on 28 June 1991. A depth survey was conducted and the bottom was found to be relatively flat with a corrected water depth of 3295 meters (Matthews correction = 1 meter and transducer depth = 3 meters). Following the depth survey the ship was positioned 4 nautical miles downwind/down swell to a position south southeast of the site. A schematic of the Southeast mooring is shown in figure 11.

The first instrumentation was deployed at 2008 UTC on 28 June 1991. Since the mooring was relatively short all but the adjustable shots fit on the winch drum. The mooring was towed for about 20 minutes prior to launching the anchor at 0137 UTC 29 June 1991. Prior to the anchor drop the drag element was positioned in the water at the starboard quarter but still tethered to the ship. As the flip plate was raised to dump the anchor the tether line was cut. The cargo net of reels followed the anchor without any apparent problem.

The ship was then repositioned so that the buoy could be tracked on radar and watched as the mooring settled out. Radar indicated that the buoy speed through the water was between 2.8 and 3.9 knots. The buoy's marine lantern helped to visually locate it and the ship's spot light was focused on the buoy. As before the buoy slowly submerged and remained submerged for about 30 seconds before rising up out of the water and remaining afloat. As time passed the buoy rode higher and higher in the water until it finally assumed the same water line as the previous toroid. Argos transmissions from the VAWR were picked up after the buoy resurfaced however no IMET data was received. The ship maneuvered close to the buoy for a visual inspection and all components appeared normal.

While near the buoy Argos telemetry from the VAWR was monitored and shipboard meteorological observations were taken every 5 minutes for a period of 30 minutes. Based on the incoming telemetered data the VAWR wind direction appeared to be incorrect by 90 - 100°. This was the same VAWR that was damaged in Madeira by the falling wire baskets and which was thought to have been repaired.

The ship remained near the buoy for several hours before moving off to conduct the anchor survey. The results of the survey (figure 12) indicated that the **GPS anchor position for the Southeast Subduction mooring (WHOI mooring number 917) was 18°00.13'N, 22°00.00'W**. Given the anchor drop position this indicates that the mooring fell back 250 meters or approximately 7.6% of the water depth. This increase in fall back may very well have been the result of the increased drag at the anchor. Following the survey the ship began steaming to the Northwest mooring site at 28°N, 34°W.

Having lost the IMET data telemetry and possibly all IMET data collection from a second buoy due to submergence and not knowing where the failure was occurring in the IMET or how to prevent the toroids from submerging a decision was made to remove the IMET package from the last toroid, leaving only the VAWR. Tests could therefore be conducted on the IMET unit at WHOI so as to identify the failure mechanism and make the necessary changes before the moorings were redeployed in February 1992.

A second attempt at keeping the toroid afloat was made by adding flotation to the Northwest toroid. One of the ship's air filled fenders was inserted in the toroid well, inflated and secured in place with three ratchet type aircraft straps. The cylindrical shaped bumper which is approximately 4 feet long and 30" in diameter fit snugly in the toroid hole when inflated and protruded above the buoy deck by about a third of its length. As placed in the toroid it would be

Figure 11. Subduction 1 Southeast Mooring Schematic

**SOUTHEAST SUBDUCTION
MOORING**

WHOI MOORING NO. 917

SIO Toroid Buoy
with 1 VAWR with Argos
Telemetry and 1 IMET System

Temperature Pods No.	Depth (m)
1	60
2	70
3	80
4	90
5	100
6	110
7	130
8	150
9	200
10	300
11	400
12	580
13	750
14	1500

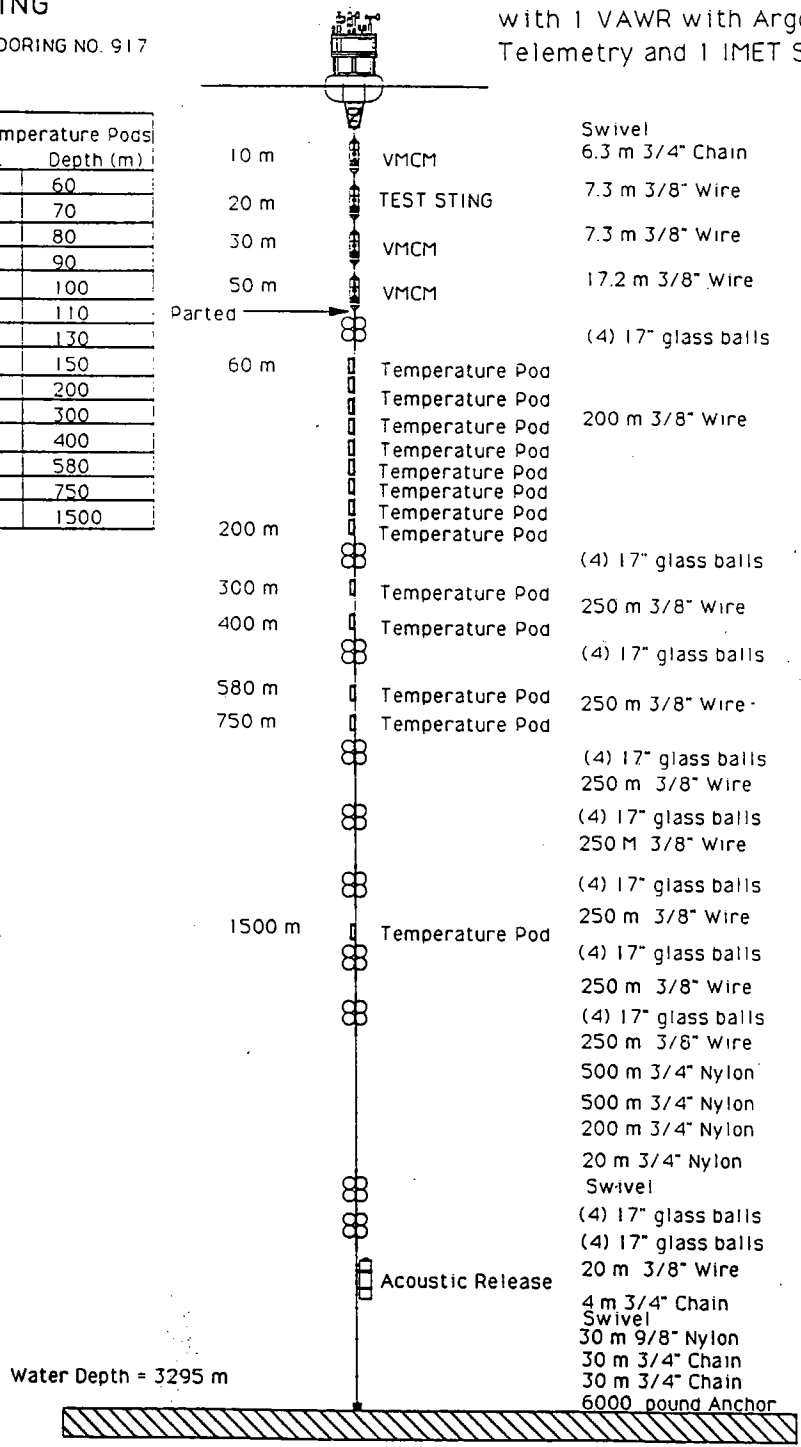

22 October 91

Figure 12. Subduction 1 Southeast Mooring Acoustic Release Survey

SOUTHEAST MOORING RELEASE SURVEY

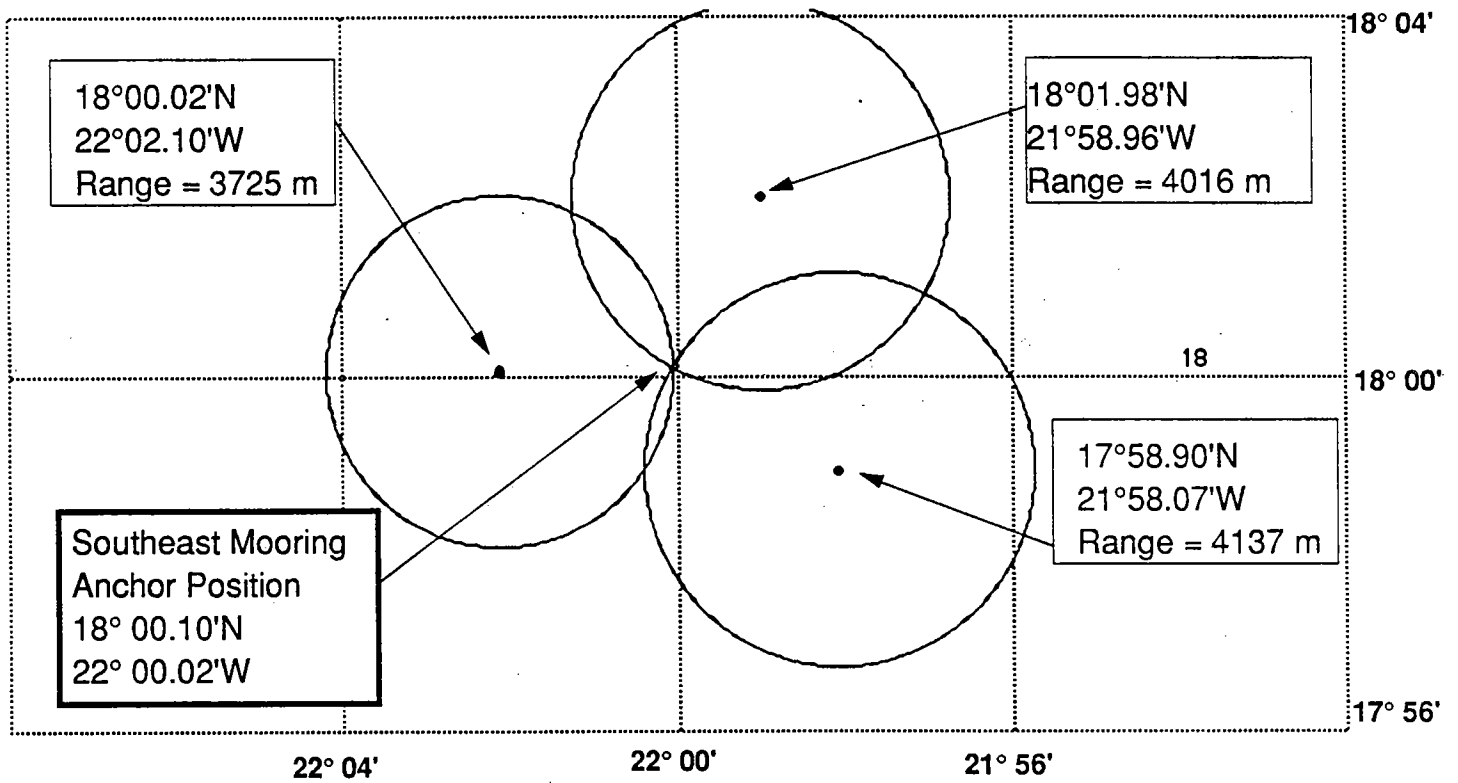

fully submerged before the tower top was in the water. Based on its volume it could potentially provide approximately 1000 pounds of buoyancy.

While enroute to the Northwest mooring site the Oceanus visited the Central Subduction mooring for a brief inspection and collection of shipboard meteorological observations. The ship arrived at the Central mooring at 0620 UTC on 1 July 1991. Prior to getting on station the buoy was detected on radar approximately 7 miles away and the marine lantern could be seen 4 miles away. While on station shipboard meteorological observations were taken every 5 minutes for 45 minutes. Simultaneously, telemetry from the buoy mounted VAWR and IMET systems was also received. Since everything appeared functional the ship was again underway for the Northwest site by 0730 UTC.

Northwest Mooring

The ship arrived at the Northwest site on 3 July 1991 at 0030 UTC. A depth survey was started as the ship approached the site and it was soon evident that the bathymetry was extremely irregular and considerably shallower than had been expected. Having seen a more desirable area 6 miles to the southeast of the proposed mooring site a decision was made to conduct a depth survey in that area. As expected the bottom in this area was extremely irregular due to its proximity to the mid-Atlantic ridge. After a detailed depth survey a new site was chosen. The corrected water depth at the new site was 3607 meters (3595 uncorrected + 10 meters Matthews Table correction + 3 meters transducer depth correction) The ship was then positioned at the site while two SIO acoustic releases were wire tested down to 1000 meters. While conducting the release tests the ship experienced a northerly set and the wind remained out of the east northeast (bearing 065°) at about 10 knots. (In hind sight more attention should have been paid to that northerly drift.)

Given the northerly drift and the need to hit the target precisely in order to be in the correct water depth the ship was positioned 6 miles downwind (east southeast) of the new anchor site. Even though the mooring was relatively short the extra distance was used as insurance in the event that we encountered any problems during the deployment.

On this particular mooring there were no instruments near the surface so the buoy and upper shot of chain were connected to the first shot of wire (with one temperature data logger at 10 meters), given plenty of scope and deployed at 0719 UTC on 3 July 1991. A schematic of the Northwest mooring is shown in figure 13. Since there was little weight under the buoy when first deployed it had a greater tendency to roll than did the other toroids. Once the buoy was deployed and aft of the ship the ship's way was decreased to zero while the mooring was rehailed to the point where the next temperature recorders could be attached. Minimum way was added after there was sufficient weight below the buoy. During this time the ship was drifting to the north at about 1 knot under the influence of what turned out to be a relatively strong current. Ship's speed was slowly increased up to 3 knots through the water before any significant easterly progress was made. Throughout the deployment the ship was steering a course of between 130° and 150° and making good a course of 090°. The mooring remained strung out behind the ship off to the northwest. The anchor was deployed at 1323 UTC in 3608 meters of water.

Immediately following the anchor deployment the ship was repositioned so as to monitor the surface buoy both visually and on radar as the anchor descended to the bottom. Surface buoy speeds reached 4 knots during which time the buoy remained inclined at a 30° angle while it traveled through the water. As the buoy became more vertical, though still traveling through the water, it submerged no deeper than 6 inches above the buoy deck. The buoy deck was submerged for less than one minute. After several minutes it had attained the same water line as the other two toroids deployed earlier. The additional flotation provided by the ship's fender was apparently sufficient to keep the buoy from becoming fully submerged.

Shipboard meteorological observations were made every 5 minutes for 30 minutes while the ship remained about 1/4 mile downwind of the buoy. The VAWR data telemetry was compared with shipboard observations and everything appeared operational.

A survey of the acoustic release position followed (figure 14). **The GPS anchor position for the Northwest Subduction mooring (WHOI mooring number 918) was 32° 54.61'N, 33° 53.50'W.** Since the mooring was strung out to the northeast the anchor fell back in that direction approximately 10.2% of the water depth.

Following the anchor survey the ship headed for Azores arriving Ponta Delgada on 5 July 1991 at 0828 UTC.

Figure 13. Subduction 1 Northwest Mooring Schematic

**NORTHWEST SUBDUCTION 1
MOORING**

WHOI Mooring No. 918

S10 Toroid Buoy
with 1 VAWR and
Argos Telemetry

Temperature Pods No.	Depth (m)
1	10
2	30
3	50
4	60
5	70
6	80
7	90
8	100
9	111
10	130
11	300
12	400
13	500
14	750
15	1500

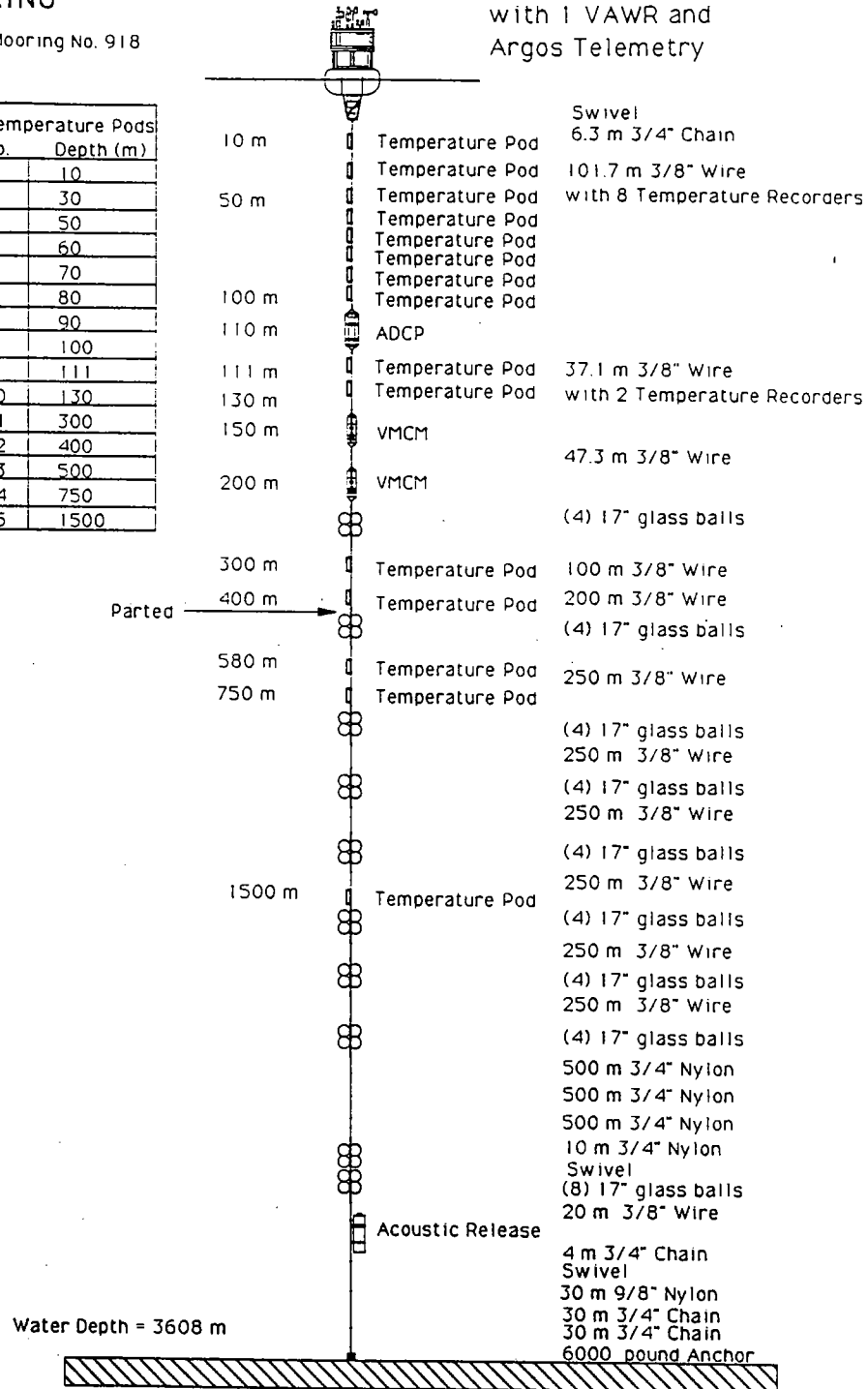

22 OCTOBER 91

Figure 14. Subduction 1 Northwest Mooring Acoustic Release Survey

Northwest Mooring Release Survey

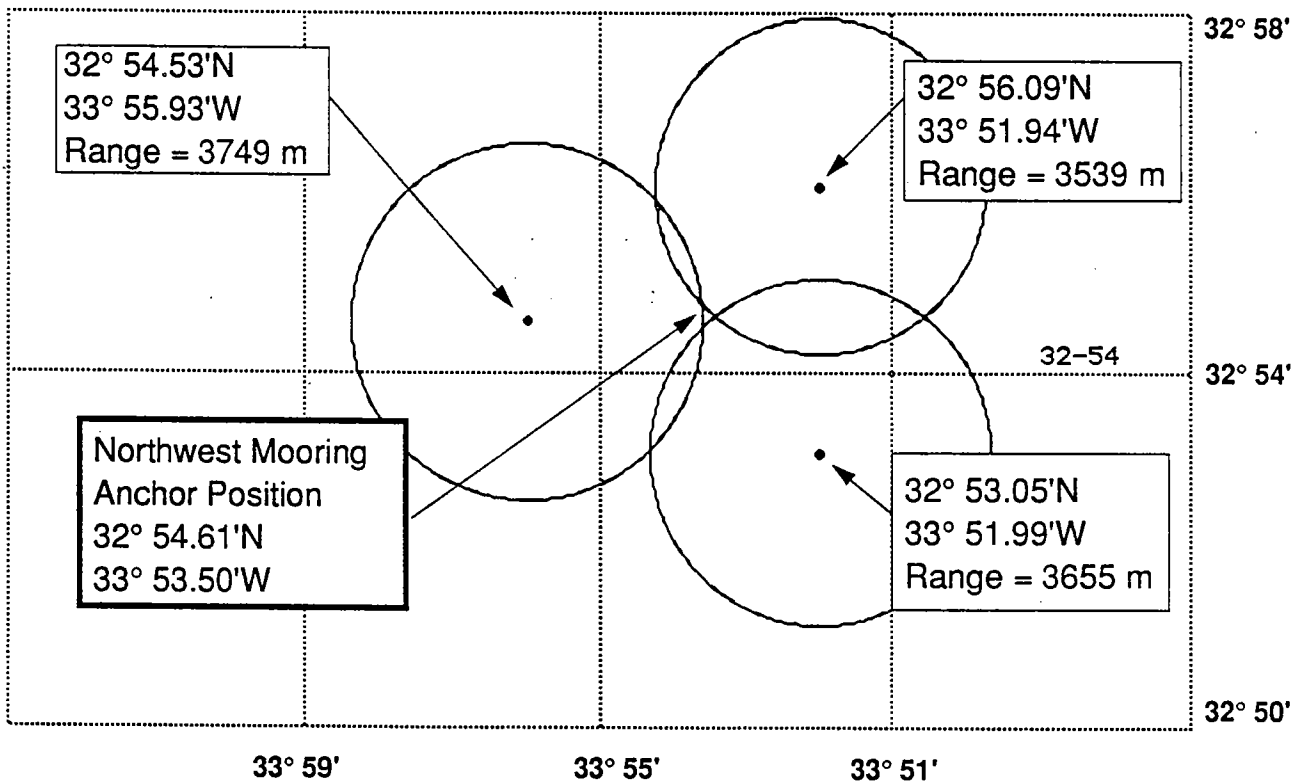

References

Trask, Richard P., Jerome P. Dean, James R. Valdes and Craig D. Marquette, 1989: FASINEX (Frontal Air-Sea Interaction Experiment) Moored Instrumentation. Woods Hole Oceanographic Institution Technical Report, WHOI-89-3, 60 pp.

Acknowledgements

The WHOI moorings deployed during Oceanus cruise number 240 were expertly designed by George Tupper and carefully prepared by the WHOI Rigging Shop under the direction of David Simoneau.

We are grateful for the skill of Captain David Casiles and the friendly assistance provided by all the crew members of the R/V Oceanus. The deployment of the moorings was carefully orchestrated by William Ostrom with invaluable help provided by Bryan Way, Paul Bouchard, Neil McPhee, Steven Abbott, Jeff Sherman, and Glenn Pezzoli. The guidance provided by Bob Weller throughout the cruise and during preparation of this report is also greatly appreciated. We sincerely thank Mary Ann Lucas for her help in preparing this report.

This work was supported by the Office of Naval Research Grant No. N00014-90-J-1490.

Appendix 1

Cruise Participants

Robert A. Weller, Chief Scientist	(WHOI)
Jeff Sherman	(SIO design engineer)
Richard P. Trask	(WHOI research specialist)
Nancy J. Pennington	(WHOI senior research assistant)
Gennaro H. Crescenti	(WHOI meteorologist)
Bryan S. Way	(WHOI engineering assistant)
Paul R. Bouchard	(WHOI engineering assistant)
William Ostrom	(WHOI senior engineering assistant)
Neil McPhee	(WHOI engineering assistant)
Stephen Abbott	(SIO development technician)
Glenn S Pezzoli	(SIO development technician)
Christine Murray	(SIO development technician)

Appendix 2

Wind Direction Sensor Comparison Tests

Part of the preparation of the meteorological packages includes checking the wind direction sensors. This consists of placing each buoy on a test station that can be rotated through 360° and directing the wind vane to a fixed target at 60° intervals. The direction is then computed from the instrument compass and vane direction data. This procedure was followed both in Woods Hole prior to shipping and again in Madeira on the dock prior to loading the buoys on the ship.

The test site in Woods Hole was located at the southern corner of the Clark - South Laboratory parking area. This site showed little horizontal or vertical spatial variation in the magnetic field. The buoys were mounted each in turn on a wooden and masonite turntable, and the direction of a tree near the Clark building was measured from six buoy orientations. At each of the six positions the wind vane was aligned to the tree by eye and locked in position. The data was then read directly from the instrument. In the case of the VAWR the compass and vane positions are added to obtain the wind vane direction in oceanographic convention (i.e. the wind direction of flow from the north is 180°). The magnetic bearing to the tree from the test site is 309.0° .

Selection of a test site in Madeira was limited to the dock area that had been allocated for our use. All the magnetic problems associated with a dock were present. Large overhead cranes, the presence of steel reinforcing rods nearby, and the unknown structure under the dock were obvious problems. The direction checks in Madeira were conducted to identify any gross problems that might have occurred in the instrumentation during shipping and should not be considered a calibration since careful selection of the site was not possible. The magnetic bearing to the distant object sited in Madeira was 352° . The data collected from both the VAWRs and IMETs are shown in Tables A2-1 and A2-2 respectively.

Algebraically summing the possible contributing errors, the maximum allowable instrumental error is six bits, and each binary bit equals 2.81° , for a total possible error of $\pm 16.9^\circ$. The individual components of this uncertainty include contributions from the compass and vane-follower which each have a linearity error specification of ± 2 bits, and a possible alignment error of ± 1 bit.

Table A2-1. VAWR wind direction sensor test results.

Pre-cruise VAWR Flow Direction Calibration Tests

Woods Hole: 26 - 29 March 1991

	NE	C	SW	SE	NW
	303	307	310	303	304
	304	305	313	301	307
	303	306	309	303	309
	306	310	309	304	309
	309	310	306	301	304
	307	312	310	304	304
Mean	305.33	308.33	309.5	302.67	306.17
Mean Diff.	-3.67	-.67	0.50	-6.33	-2.83

Funchal, Madeira: 8-9 June 1991

	346	352	346	358	351
	349	349	349	360	355
	346	348	346	352	352
	346	352	349	352	355
	349	349	346	351	351
	349	351	352	354	353
Mean	347.50	350.17	348.00	354.50	352.83
Mean Diff.	-4.50	-1.83	-4.00	2.50	.83

Mean = average of six values

Diff. = (VAWR minus Landmark heading)

Mean Diff. = mean of six Diff. values

Table A2-2. IMET wind direction sensor test results.

Precruise IMET Flow Direction Calibration Tests
 Woods Hole: 26 - 29 March 1991

	NE	C	SW	SE	NW
	310.8	310.4	307.9	310.9	306.7
	310.1	309.0	306.2	311.5	309.6
	310.0	308.0	305.0	312.9	307.6
	309.9	311.6	306.0	311.9	305.7
	309.6	308.3	311.1	311.8	306.4
	310.0	310.0	305.8	310.2	306.6
Mean	310.07	309.55	307.0	311.53	307.1
Mean Diff.	1.07	0.55	-2.0	2.53	-1.90

Funchal, Madeira 8-9 June 1991

	352.0	352.3	353.1	350.3	355.1
	352.0	350.8	349.7	351.6	350.5
	350.1	352.6	350.9	353.5	350.5
	352.4	350.5	348.5	350.8	348.6
	350.7	351.0	348.2	354.1	349.3
	354.3	351.5	348.1	352.5	350.5
Mean	351.92	351.45	349.75	352.13	350.75
Mean Diff.	-.08	-.55	-2.25	.13	-1.25

Mean = average of six values

Diff. = (VAWR minus Landmark heading)

Mean Diff. = mean of six Diff. values

Appendix 3

XBT Data

Two hundred and fifty-six XBTs were deployed during OC-240. The T-7 probes were purchased from Sippican Inc. of Marion, Massachusetts. The XBT data were logged on a NEC APC IV which had a Spartan of Canada Ltd. data acquisition microprocessor card installed. The digital data was simultaneously logged in memory and plotted on the screen.

Figure A3-1(a through aa) shows the XBT profiles in groups of ten. Table A3-1 contains the positions and time of the XBTs. Figure A3-2a shows the ship track where the hourly XBTs were dropped. Figure A3-2b through A3-2d are contour plots of XBT temperatures at the surface, 200 meters depth, and 500 meters depth respectively. Figure A3-3 details the location of the XBT sections that appear in Figure A3-4.

XBTs 1-36 have an offset because of a defective Spartan card in the NEC PC-AT.

Figure A3-1a. Overplot of XBT Profiles 1-9
Successive Profiles are offset by 1° C.

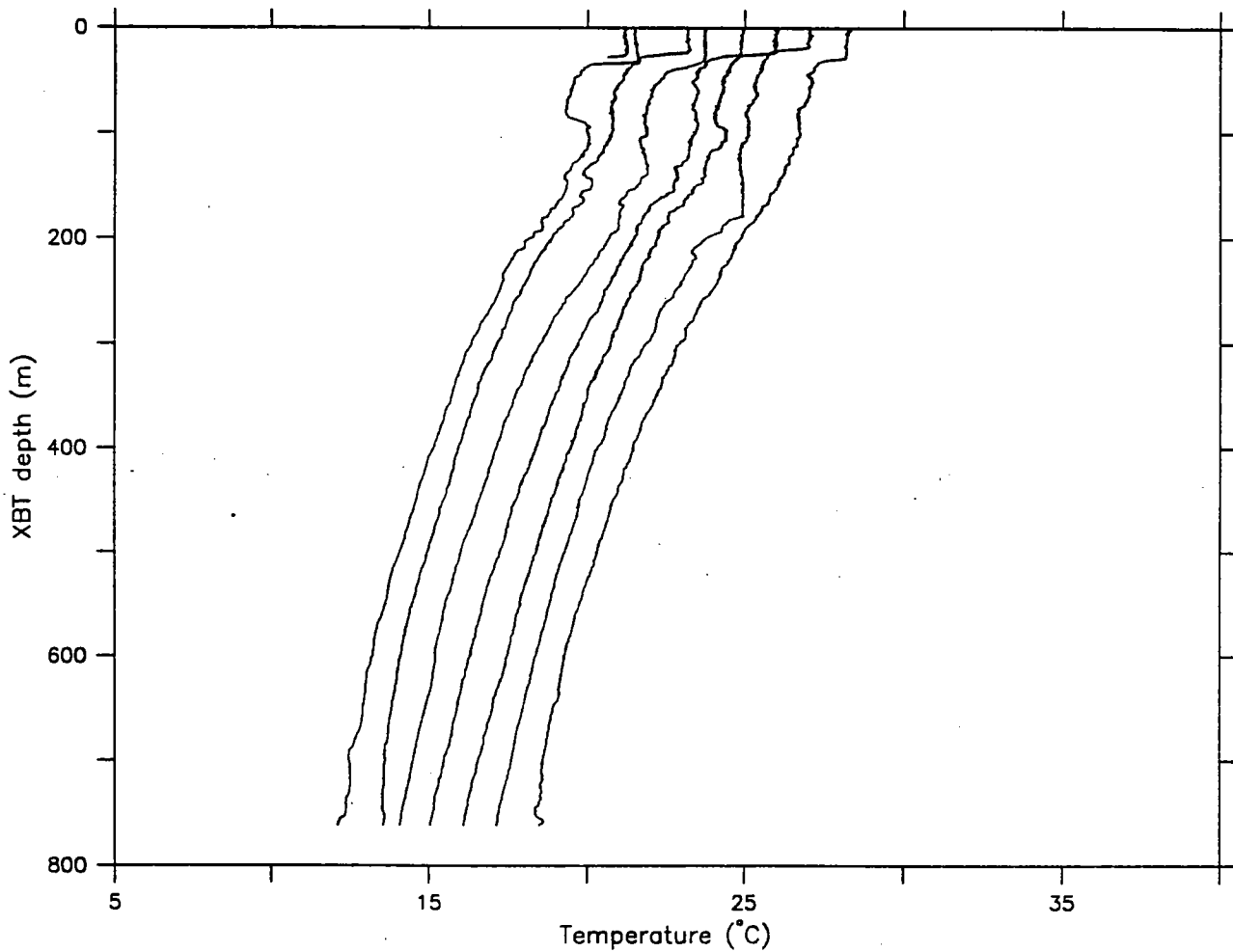

Subduction | XBT start: 1 offset by 1°C

Figure A3-1b. Overplot of XBT Profiles 10-19
Successive Profiles are offset by 1° C.

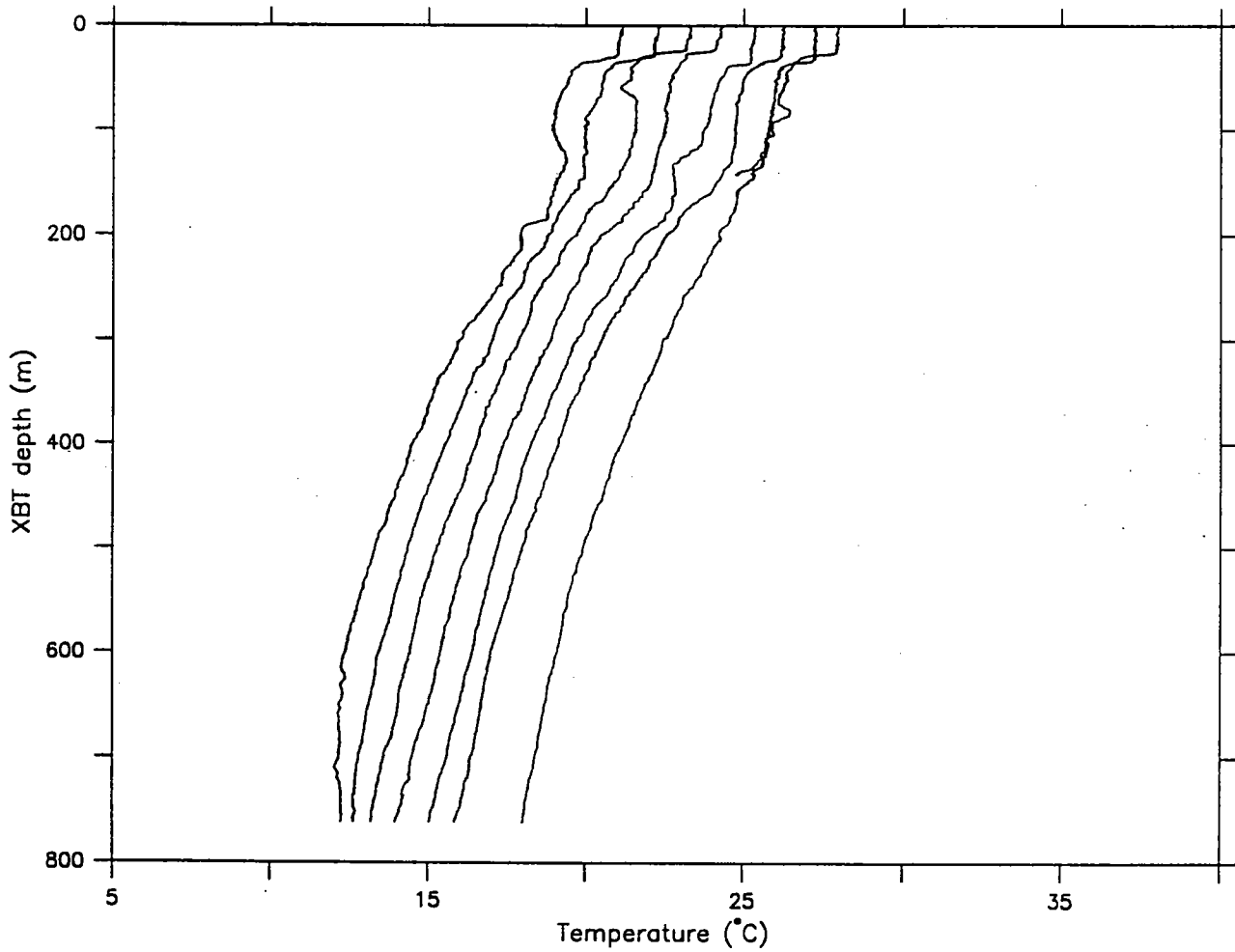

Subduction | XBT start: 10 offset by 1°C

Figure A3-1c. Overplot of XBT Profiles 20-29
Successive Profiles are offset by 1° C.

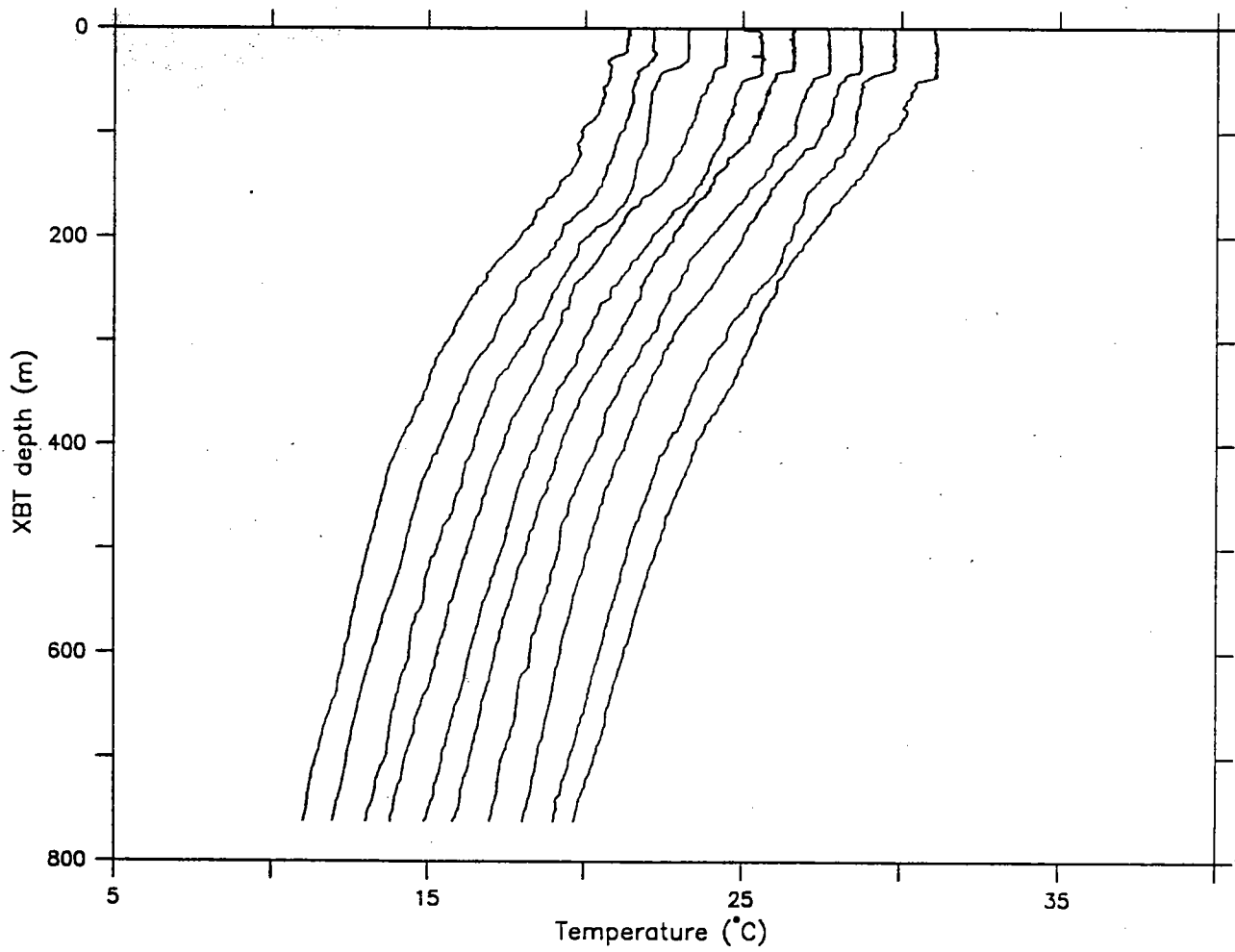

Subduction | XBT start: 20 offset by 1°C

Figure A3-1d. Overplot of XBT Profiles 30-39
Successive Profiles are offset by 1° C.

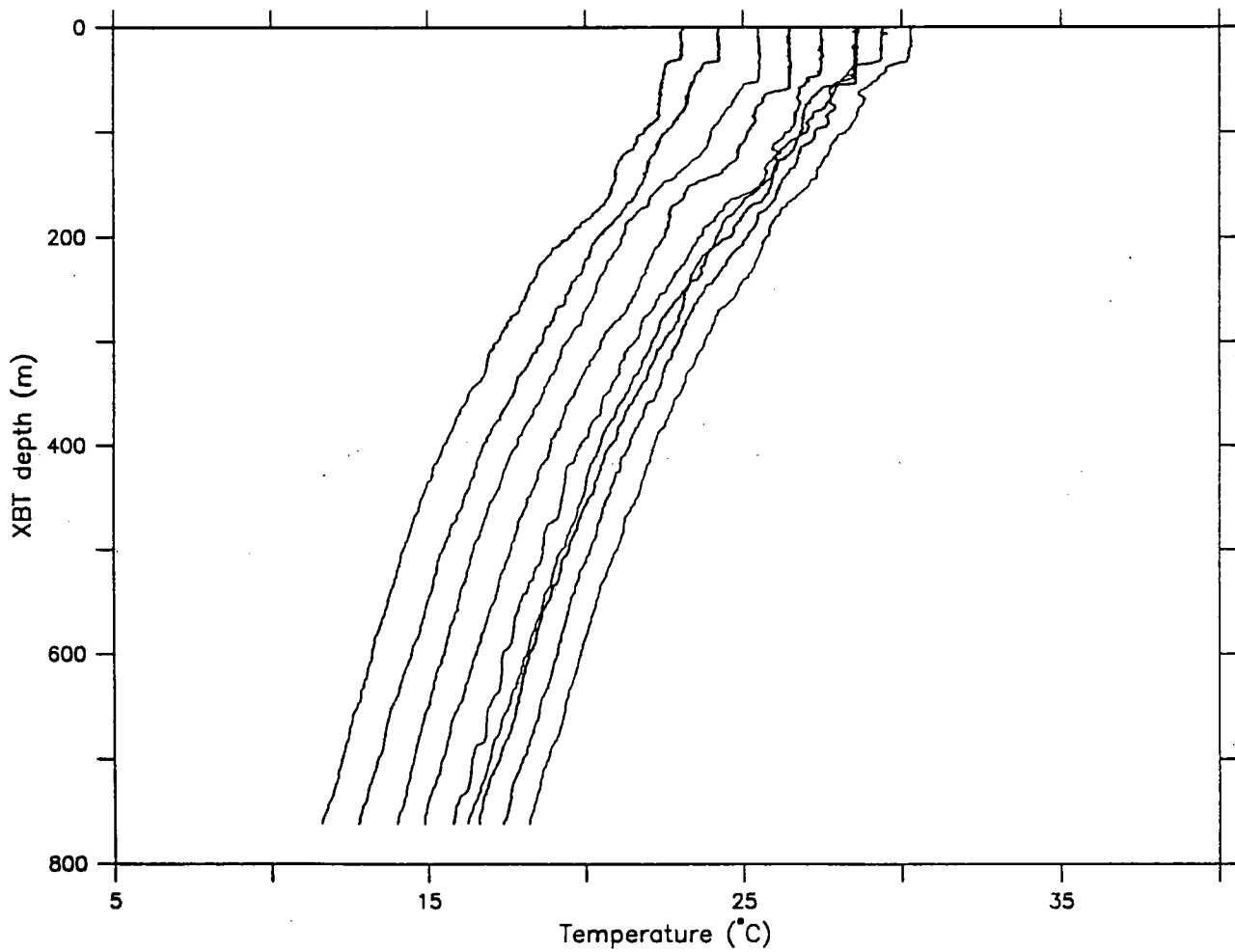

Subduction I XBT start: 30 offset by 1°C

Figure A3-1e. Overplot of XBT Profiles 40-49
Successive Profiles are offset by 1° C.

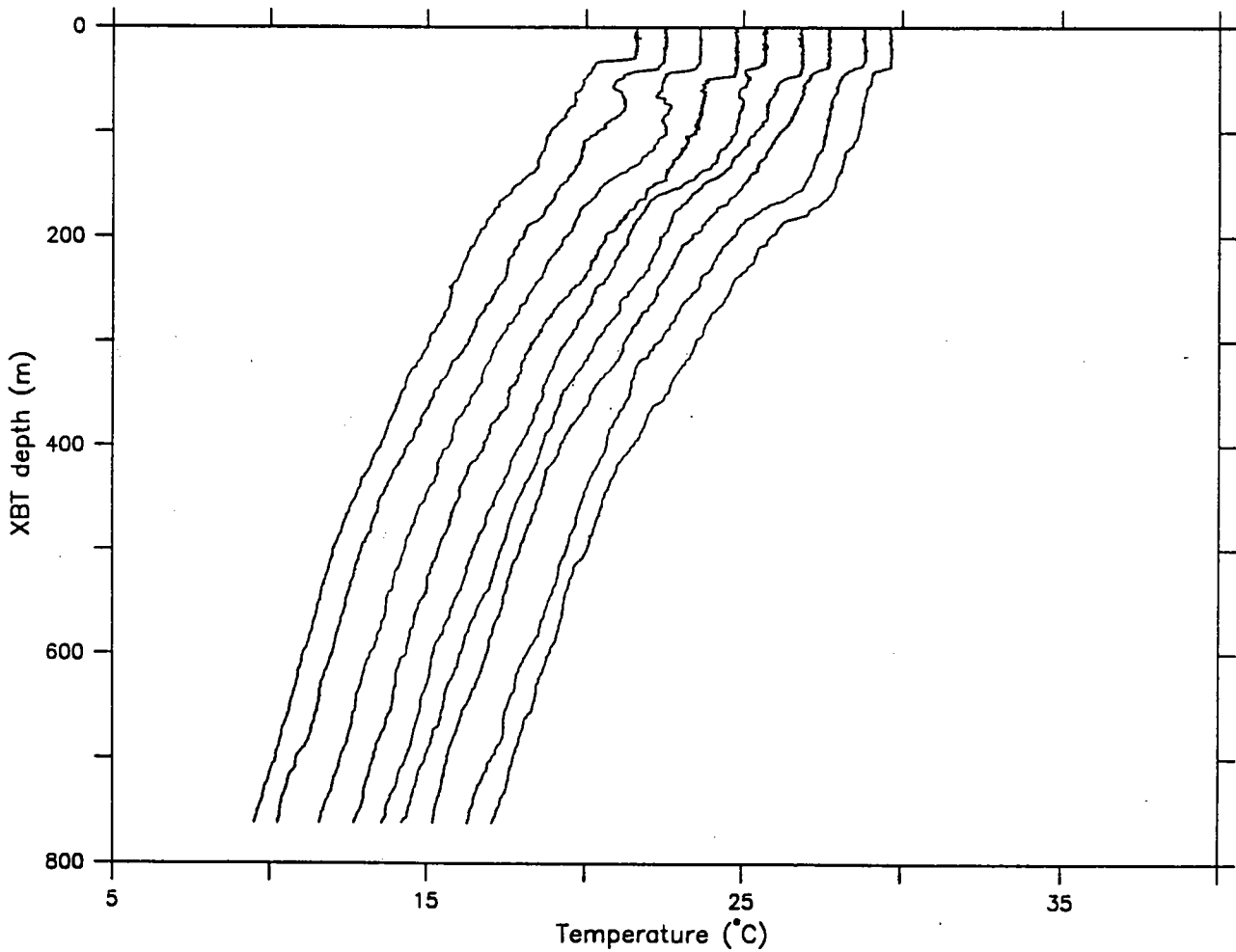

Subduction | XBT start: 40 offset by 1°C

Figure A3-1f. Overplot of XBT Profiles 50-59
Successive Profiles are offset by 1° C.

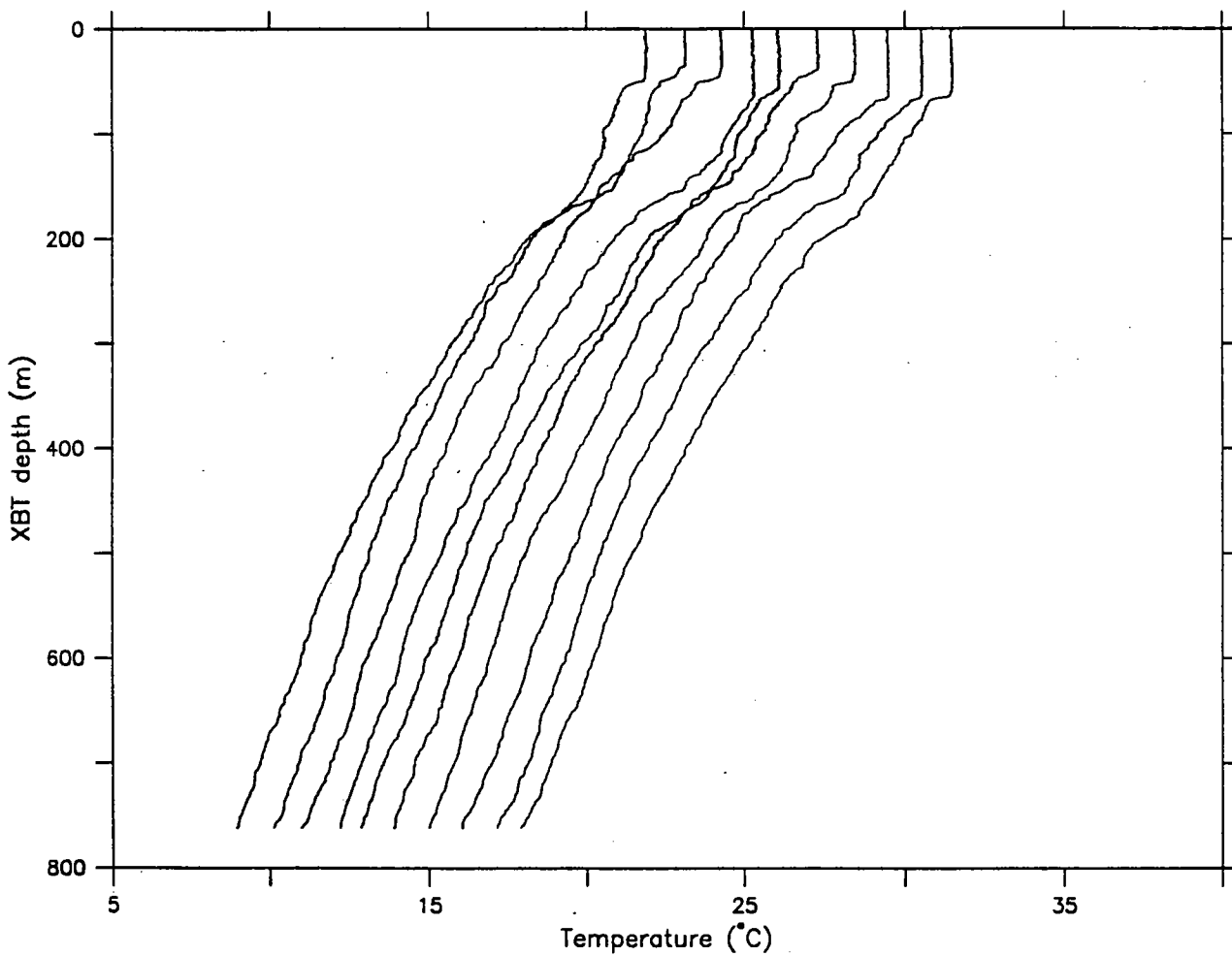

Subduction I XBT start: 50 offset by 1° C

Figure A3-1g. Overplot of XBT Profiles 60-69
Successive Profiles are offset by 1° C.

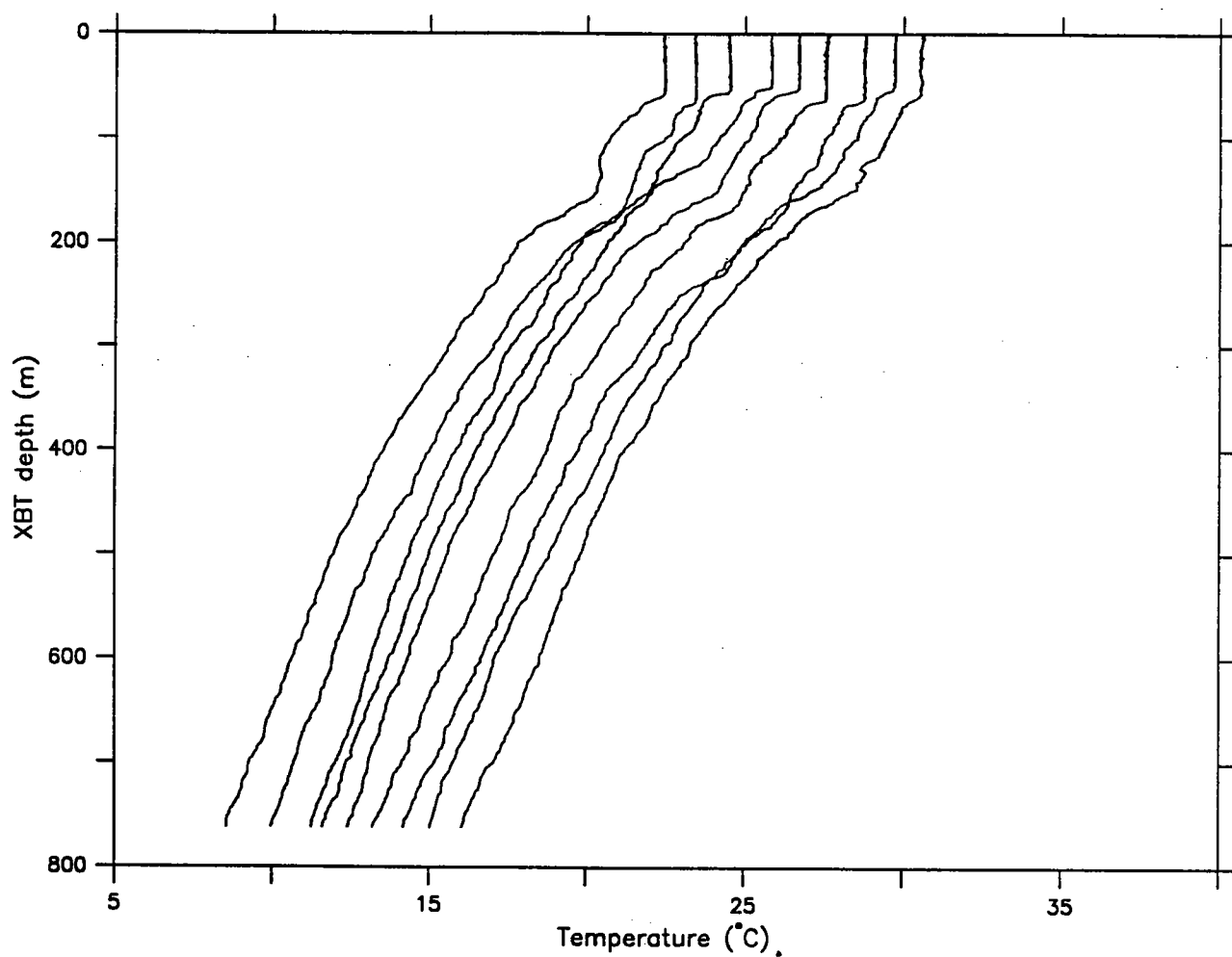

Subduction I XBT start: 60 offset by 1° C

Figure A3-1h. Overplot of XBT Profiles 70-79
Successive Profiles are offset by 1° C.

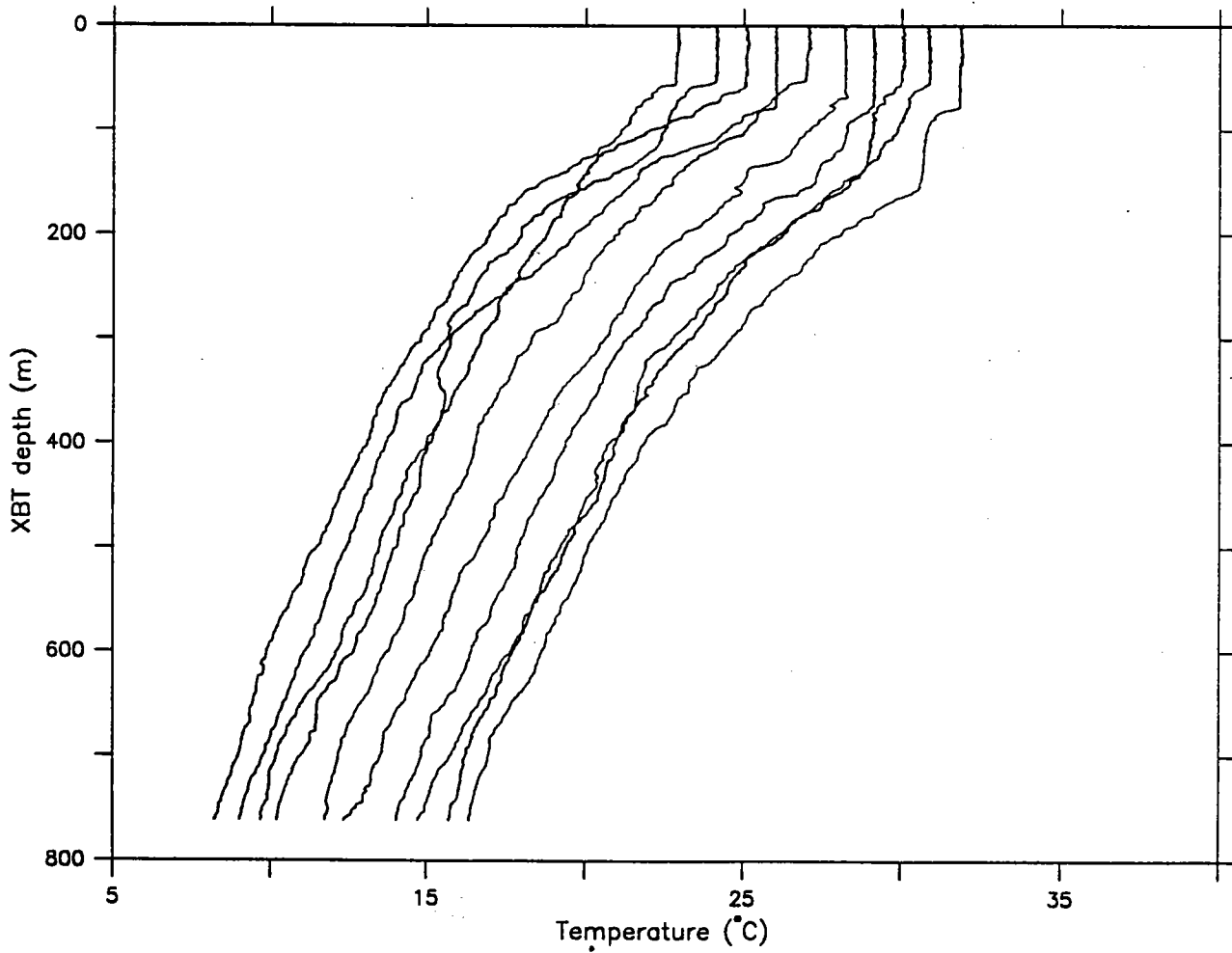

Subduction | XBT start: 70 offset by 1°C

Figure A3-1i. Overplot of XBT Profiles 80-89
Successive Profiles are offset by 1° C.

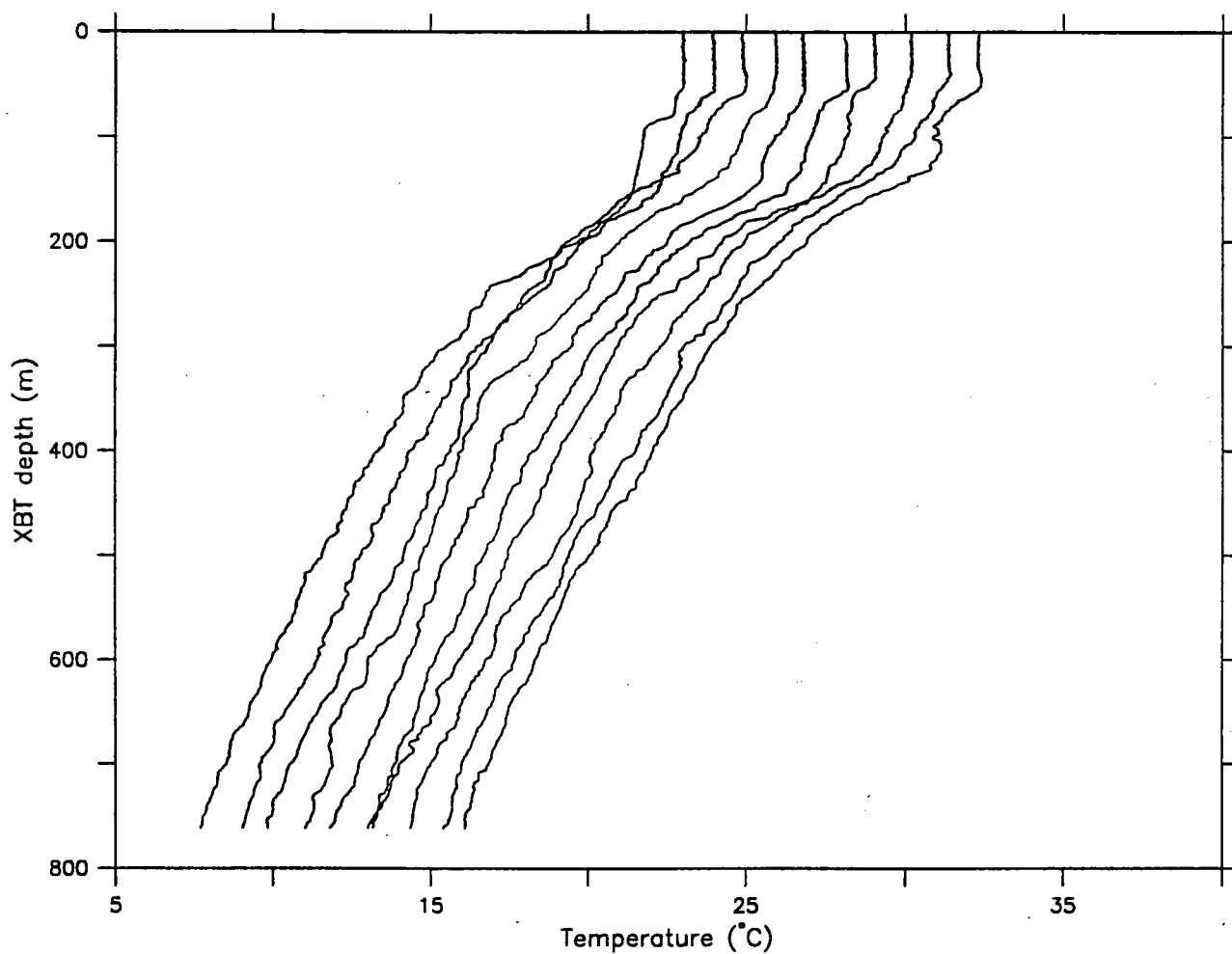

Subduction | XBT start: 80 offset by 1°C

Figure A3-1j. Overplot of XBT Profiles 90-99
Successive Profiles are offset by 1° C.

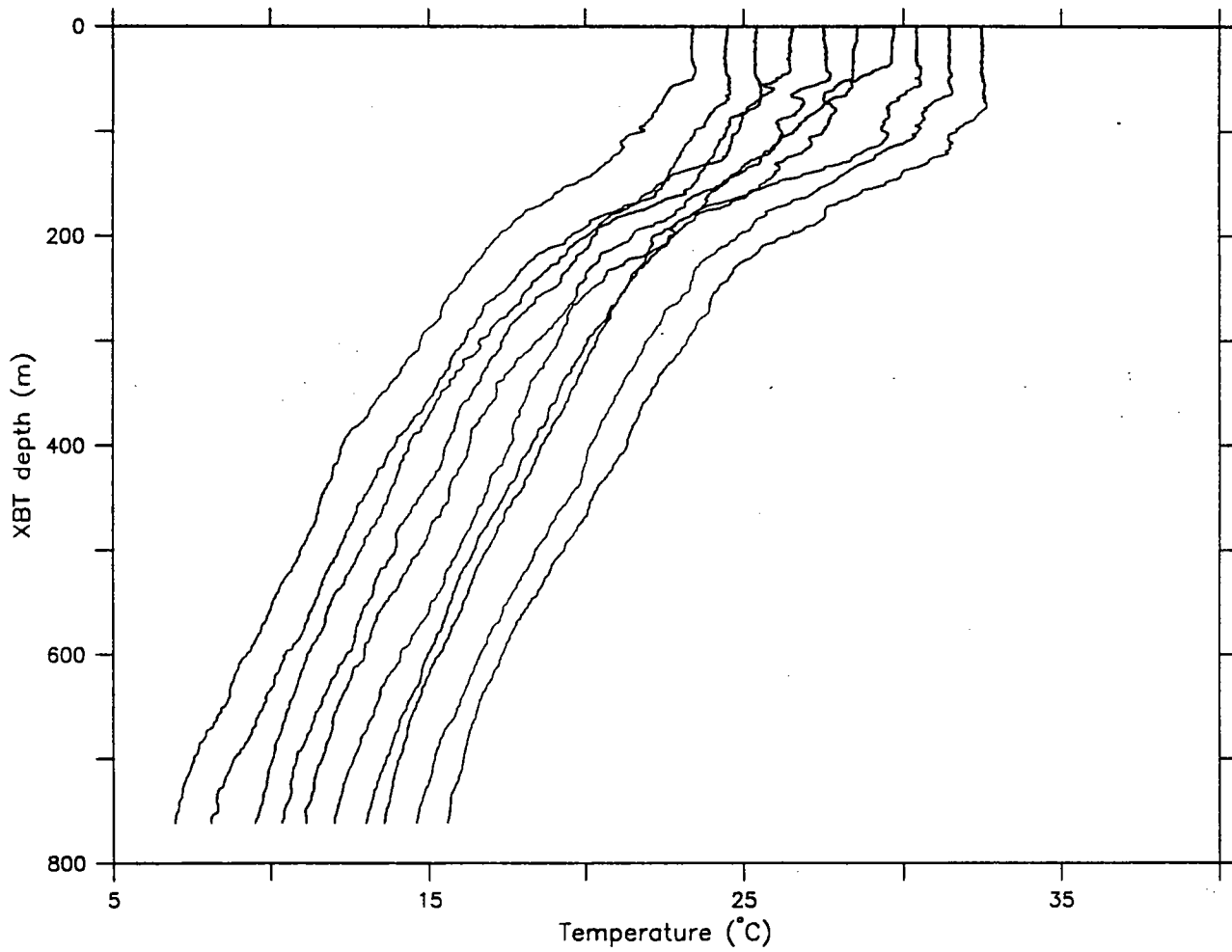

Subduction | XBT start: 90 offset by 1°C

Figure A3-1k. Overplot of XBT Profiles 100-109
Successive Profiles are offset by 1° C.

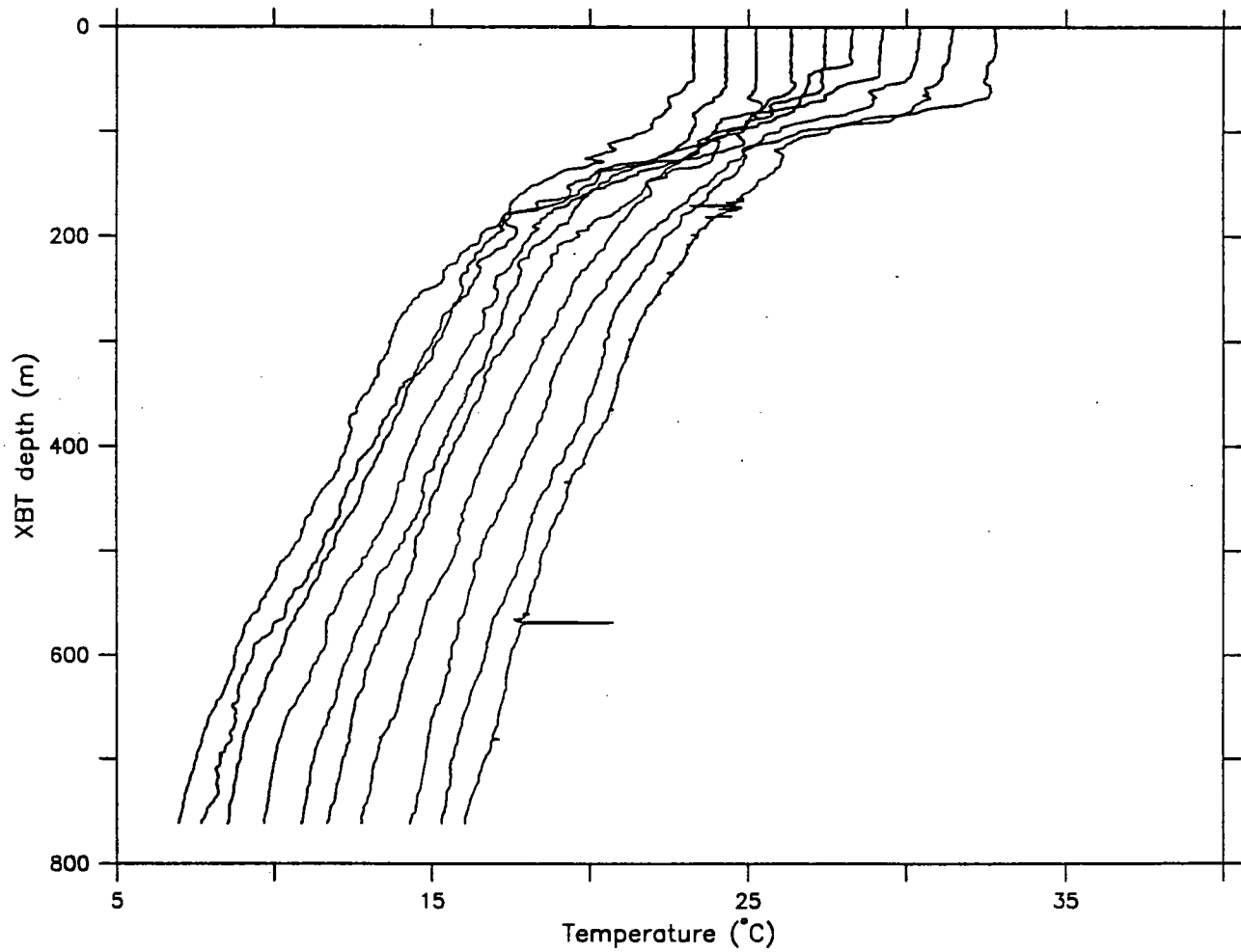

Subduction I XBT start: 100 offset by 1° C

Figure A3-11. Overplot of XBT Profiles 110-119
Successive Profiles are offset by 1° C.

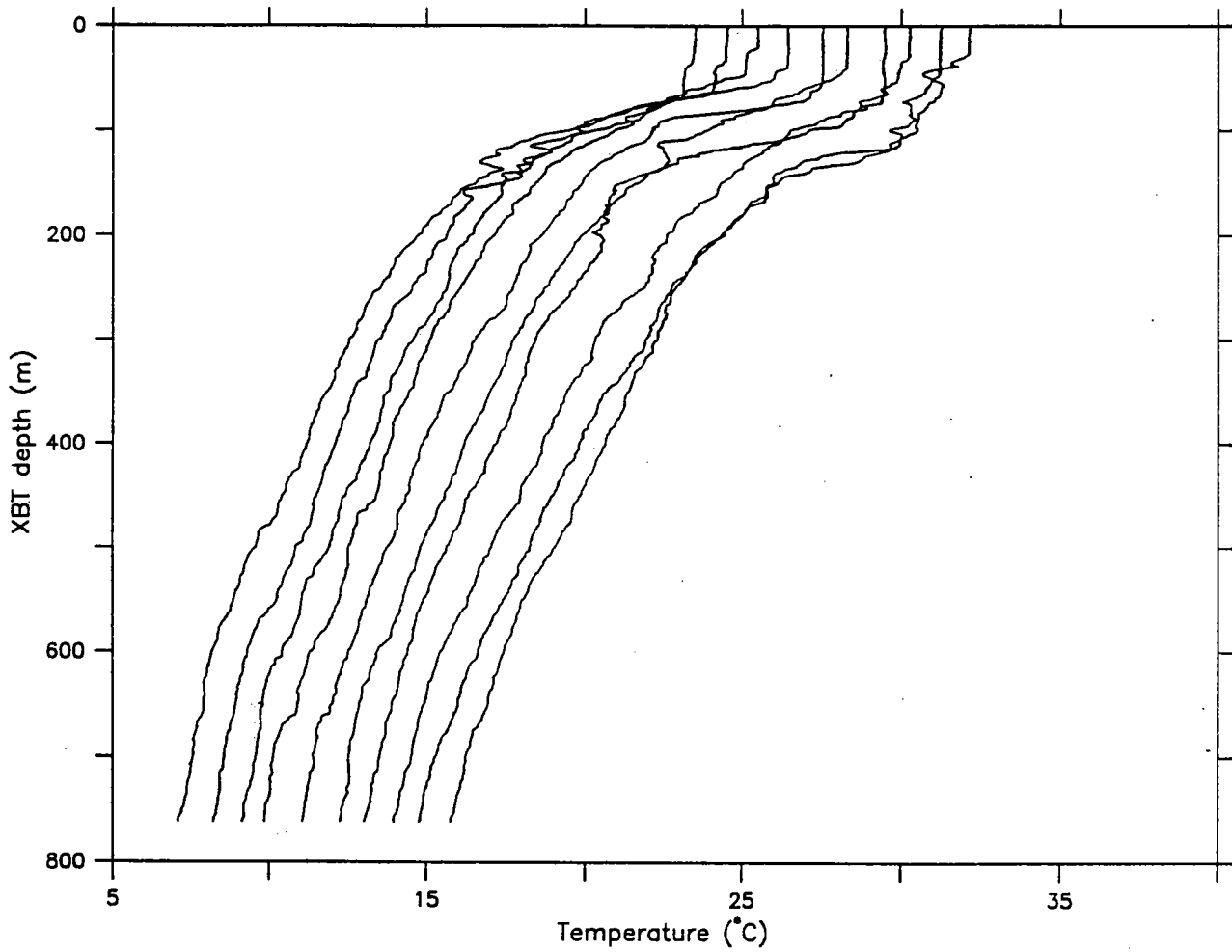

Subduction | XBT start: 110 offset by 1°C

Figure A3-1m. Overplot of XBT Profiles 120-129
Successive Profiles are offset by 1° C.

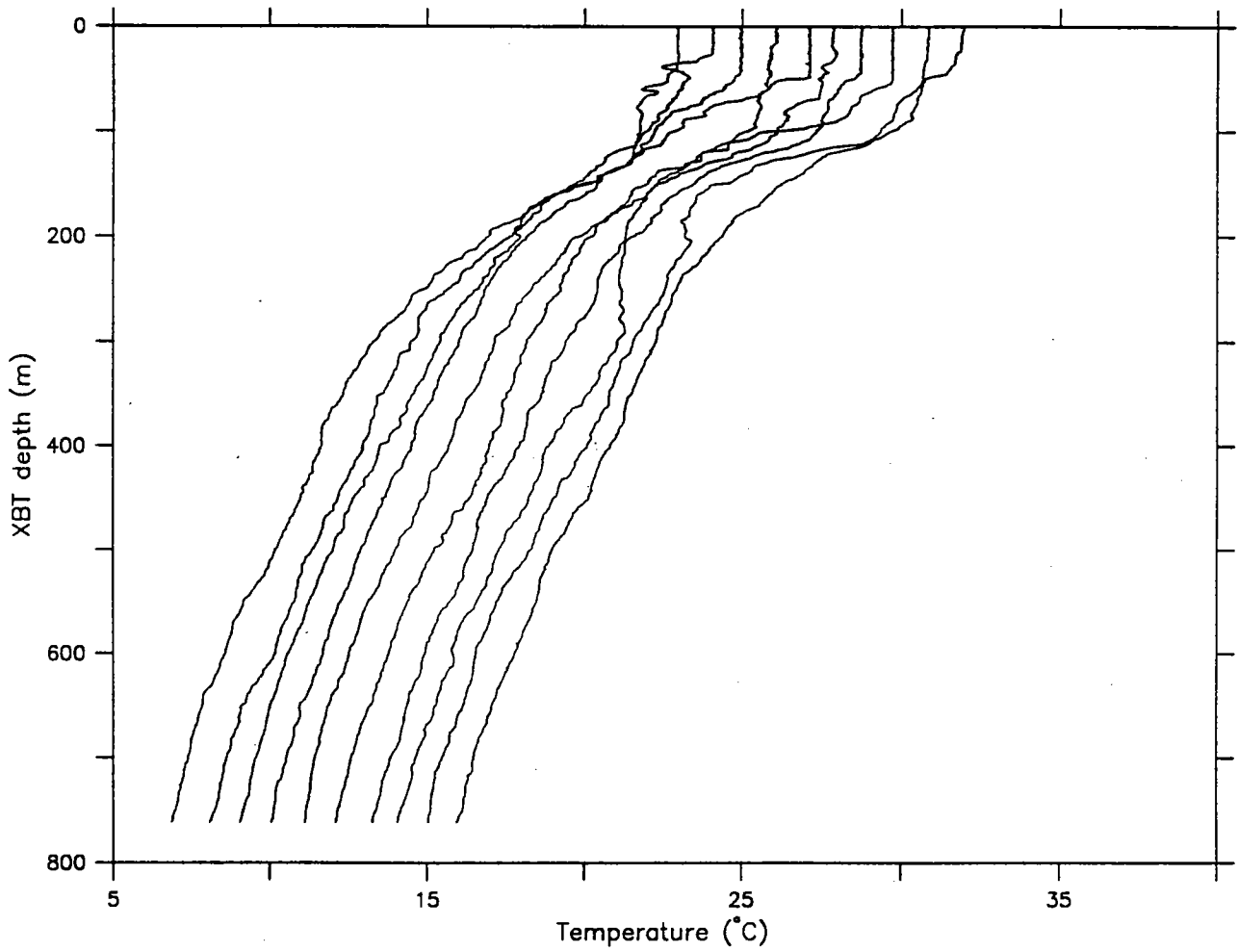

Subduction | XBT start: 120 offset by 1°C

Figure A3-1n. Overplot of XBT Profiles 130-139
Successive Profiles are offset by 1° C.

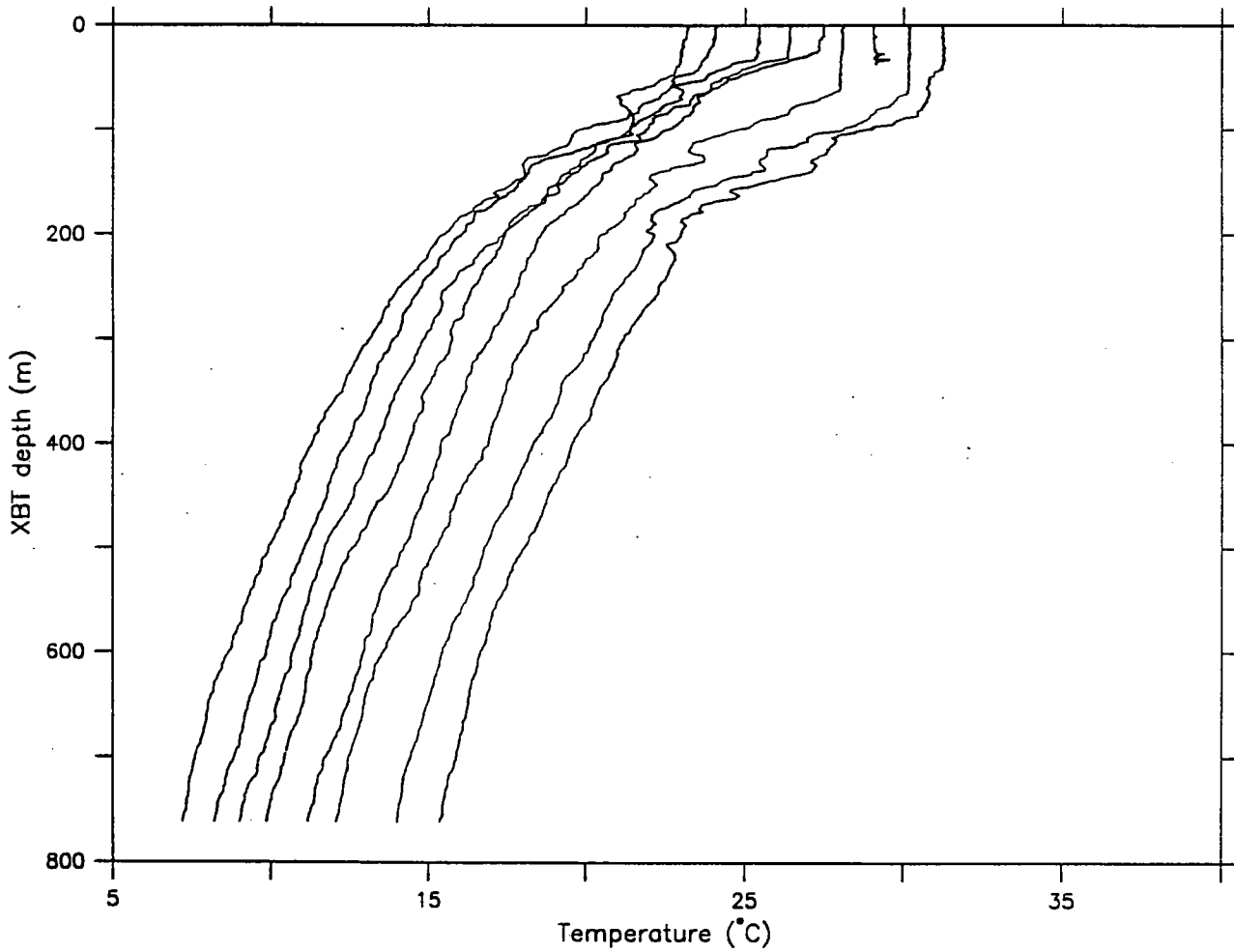

Subduction | XBT start: 130 offset by 1°C

Figure A3-10. Overplot of XBT Profiles 140-149
Successive Profiles are offset by 1° C.

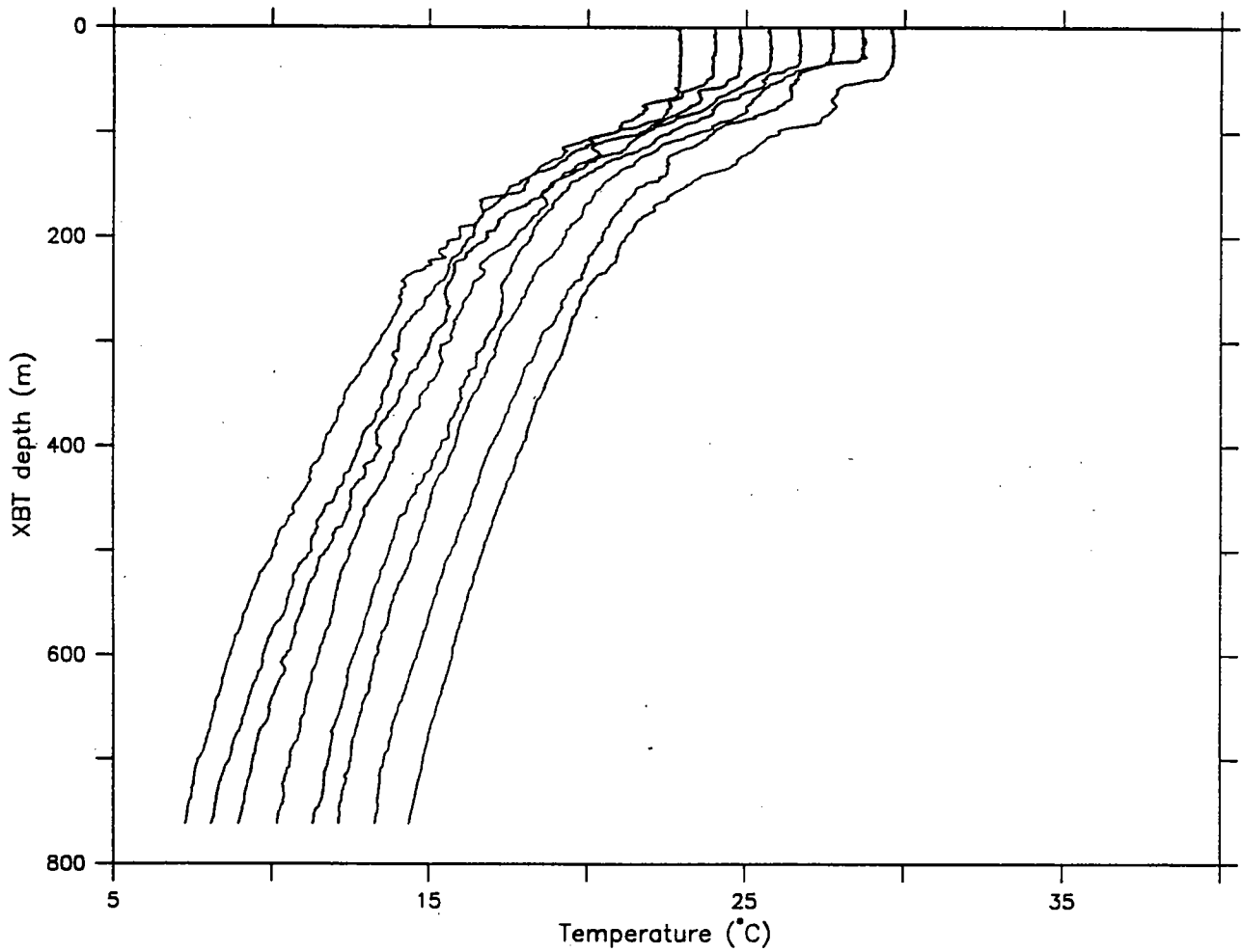

Subduction | XBT start: 140 offset by 1°C

Figure A3-1p. Overplot of XBT Profiles 150-159
Successive Profiles are offset by 1° C.

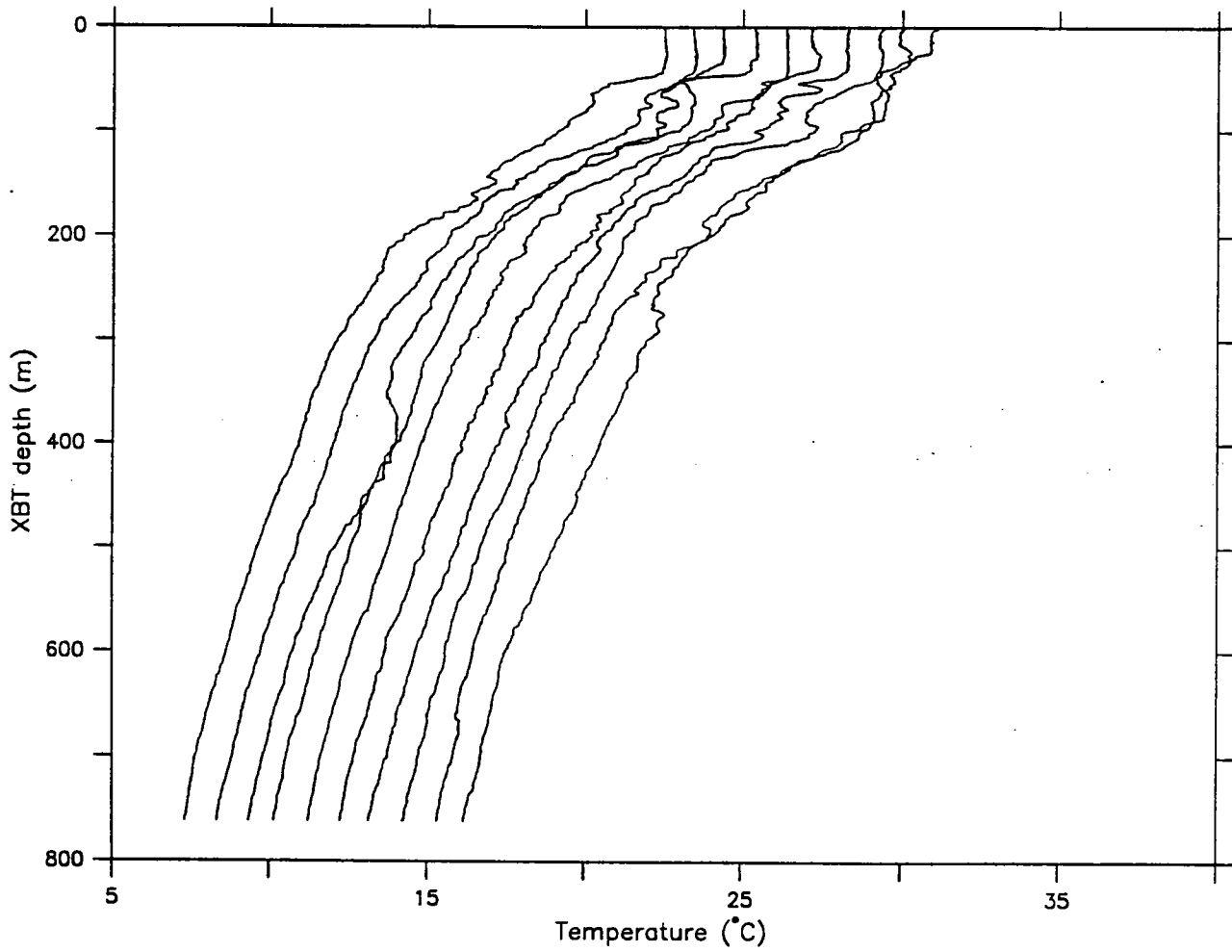

Subduction I XBT start: 150 offset by 1°C

Figure A3-1q. Overplot of XBT Profiles 160-169
Successive Profiles are offset by 1° C.

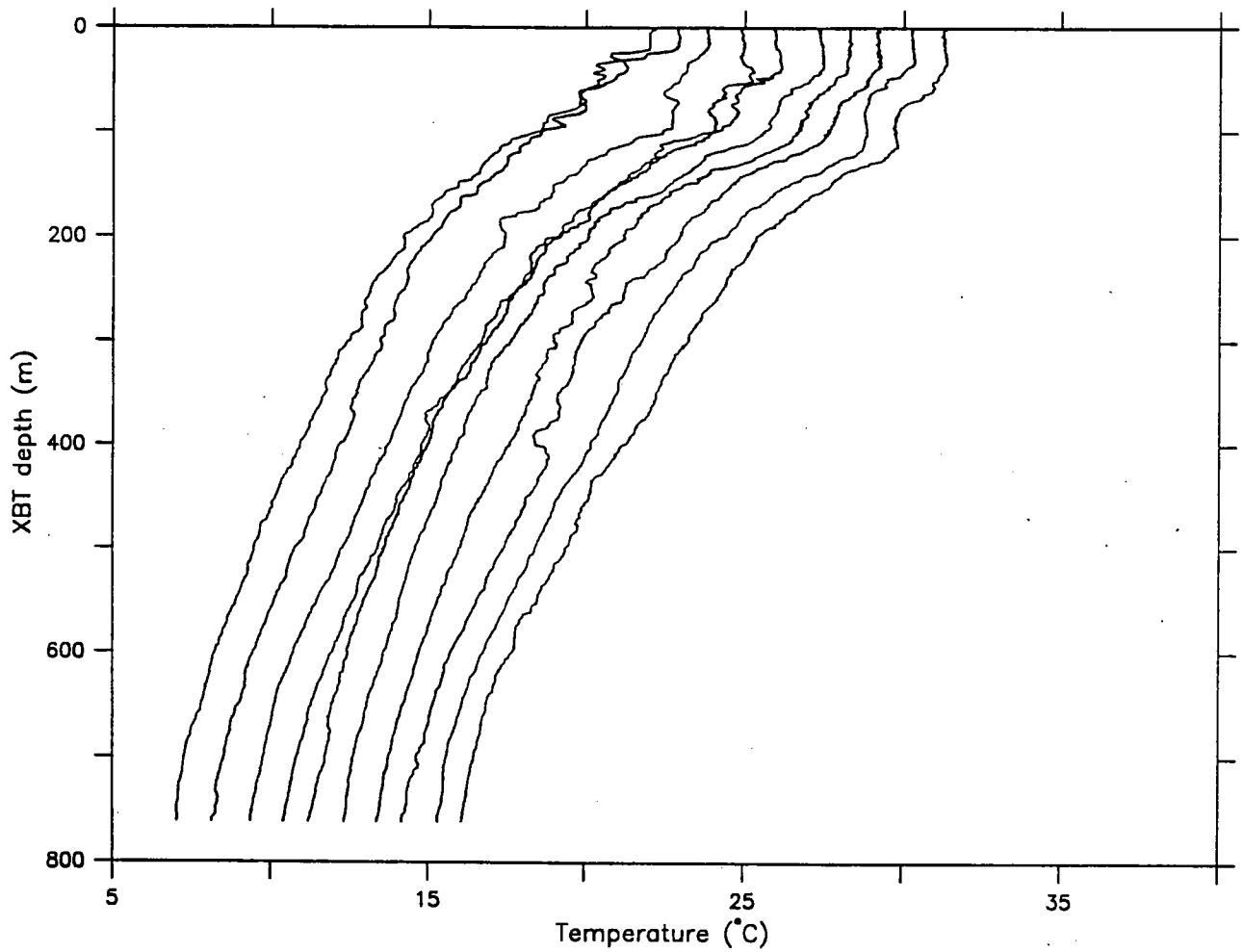

Subduction | XBT start: 160 offset by 1°C

Figure A3-1r. Overplot of XBT Profiles 170-179
Successive Profiles are offset by 1° C.

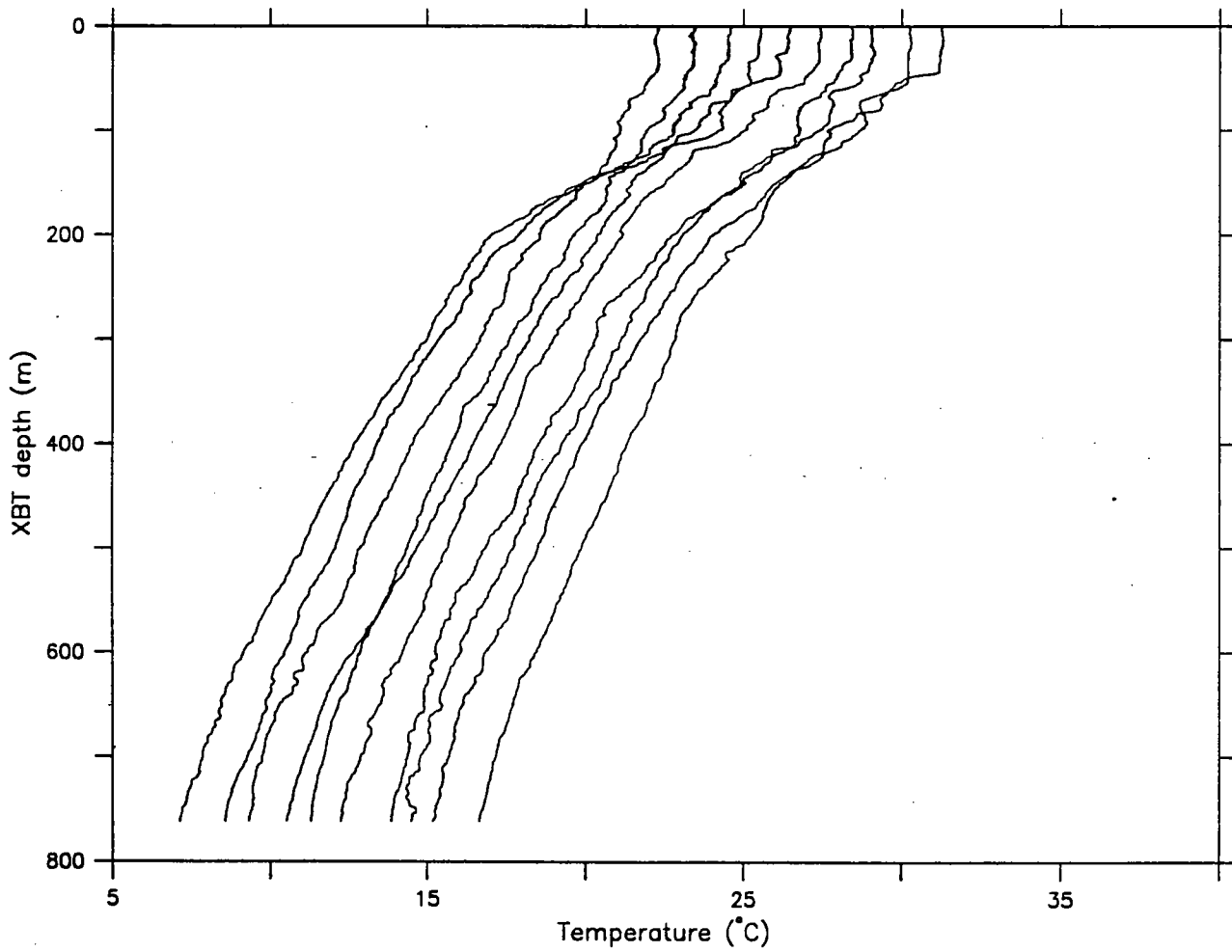

Subduction | XBT start: 170 offset by 1°C

Figure A3-1s. Overplot of XBT Profiles 180-189
Successive Profiles are offset by 1° C.

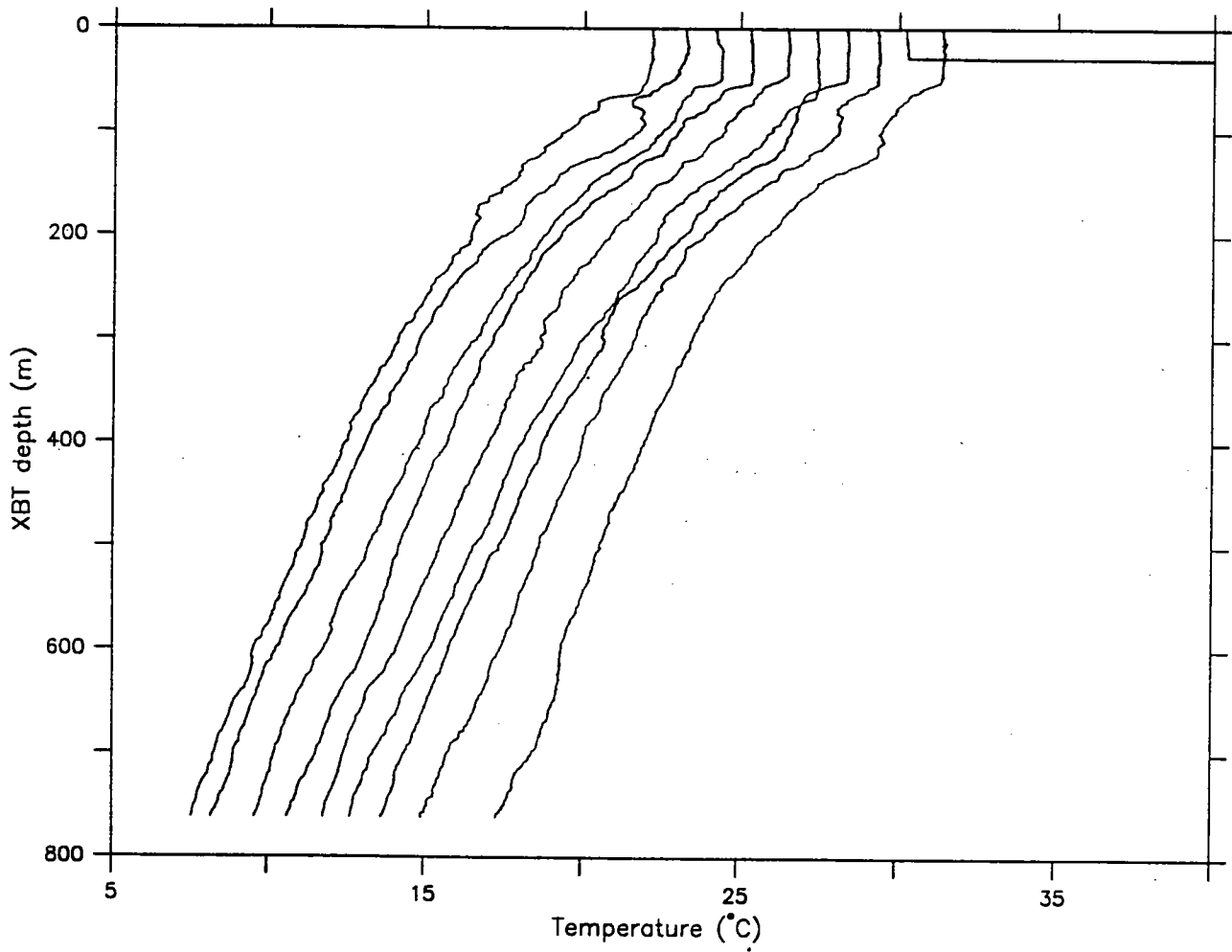

Subduction I XBT start: 180 offset by 1°C

Figure A3-1t. Overplot of XBT Profiles 190-199
Successive Profiles are offset by 1° C.

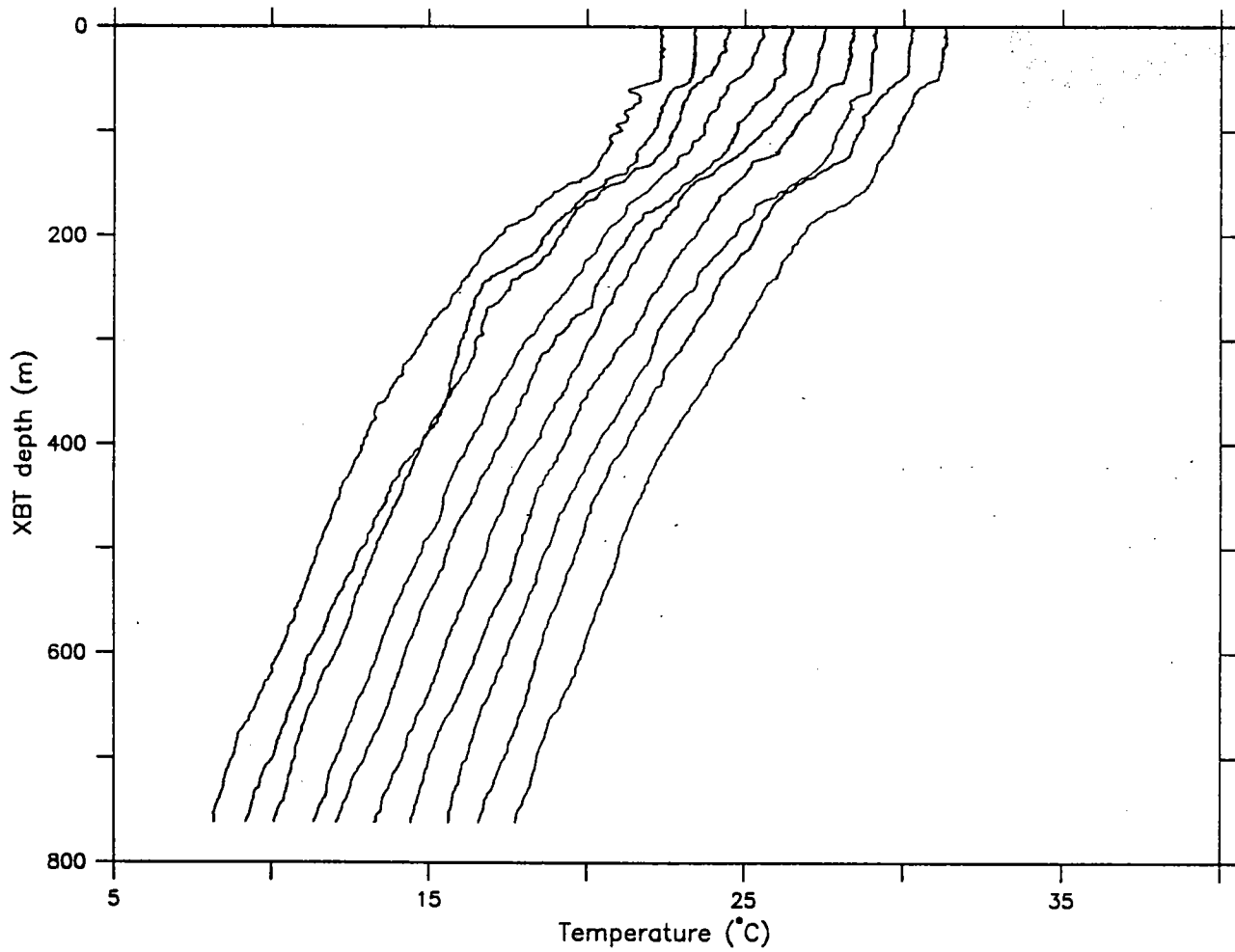

Subduction | XBT start: 190 offset by 1°C

Figure A3-1u. Overplot of XBT Profiles 200-209
Successive Profiles are offset by 1° C.

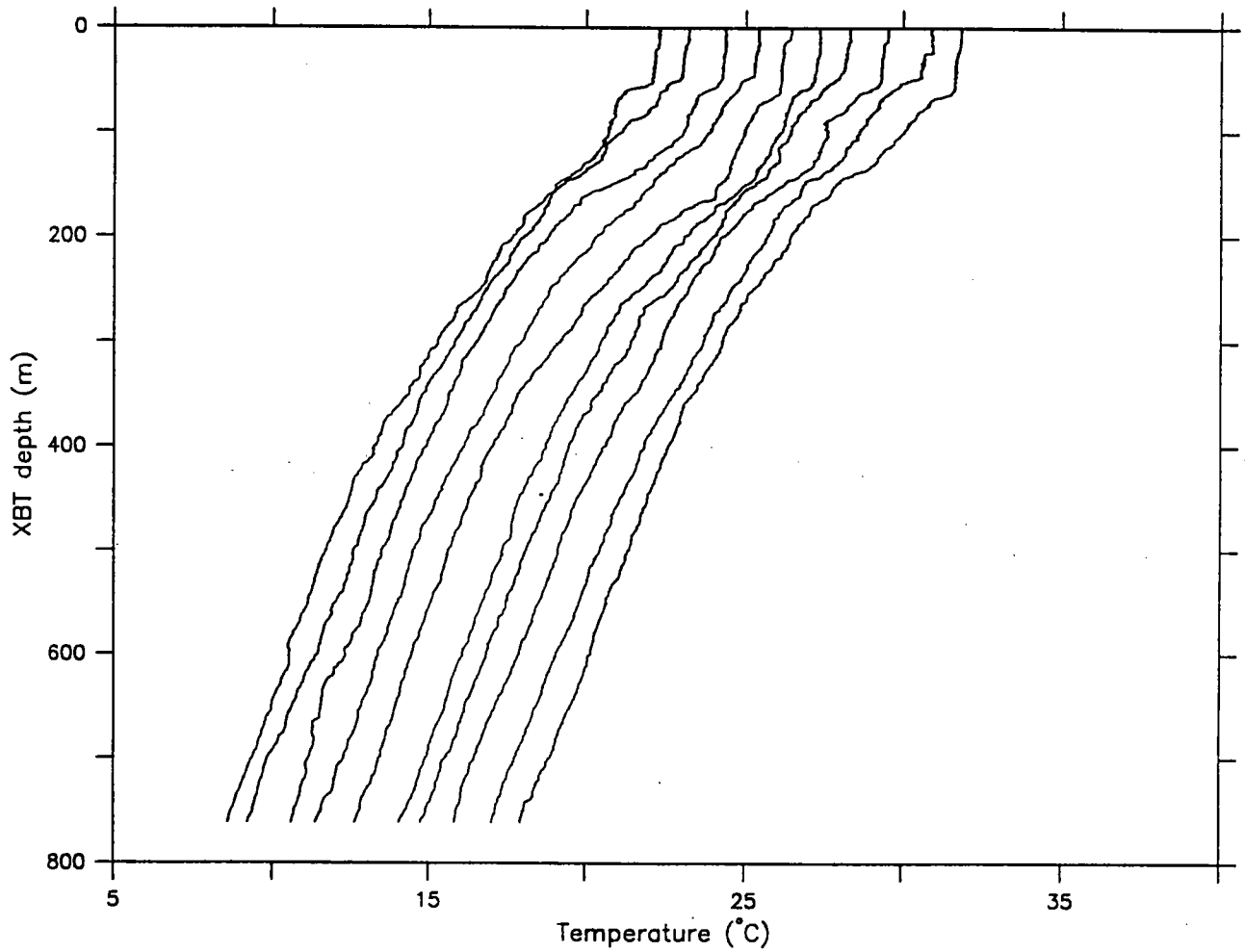

Subduction | XBT start: 200 offset by 1°C

Figure A3-1v. Overplot of XBT Profiles 210-219
Successive Profiles are offset by 1° C.

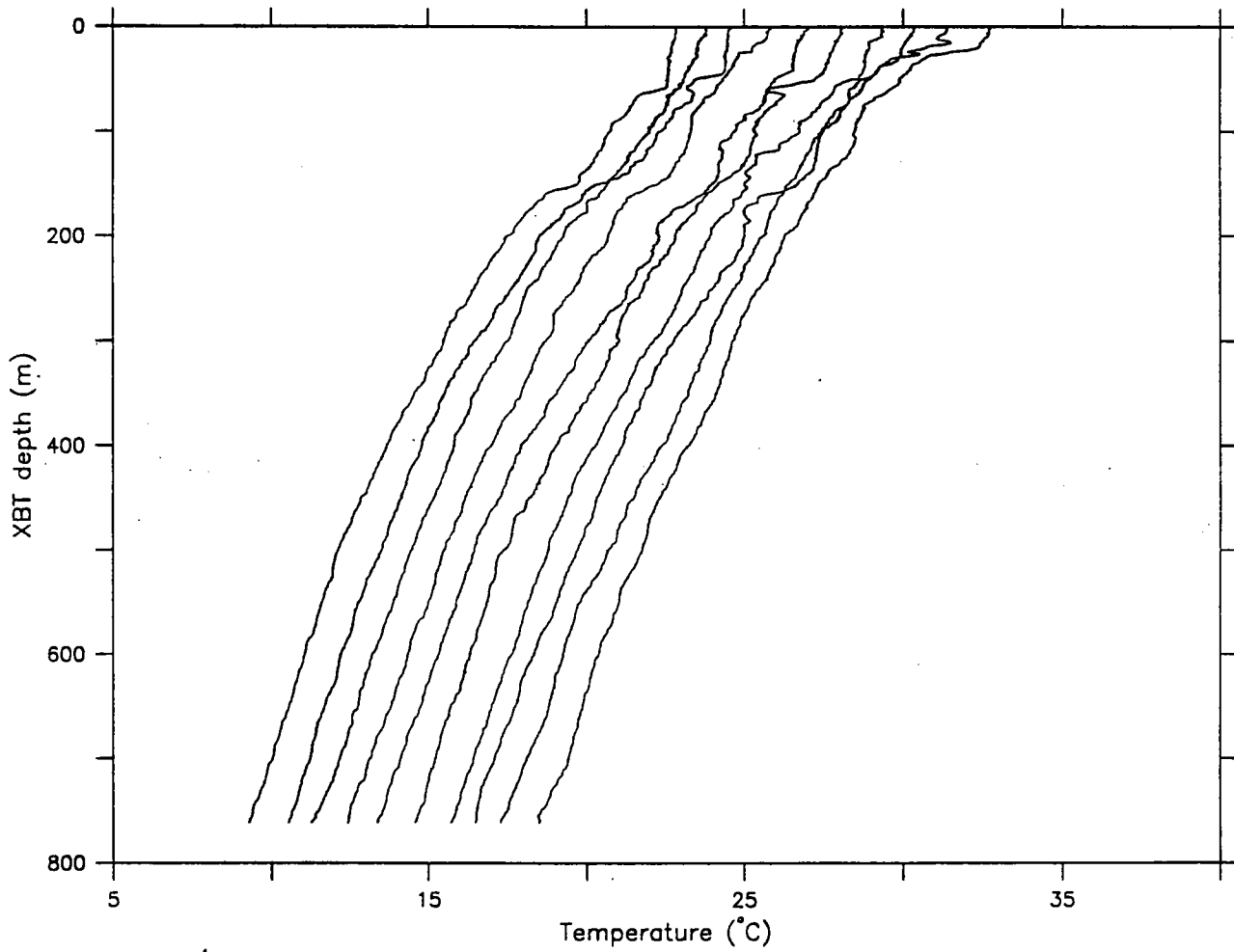

Subduction | XBT start: 210 offset by 1°C

Figure A3-1w. Overplot of XBT Profiles 220-229
Successive Profiles are offset by 1° C.

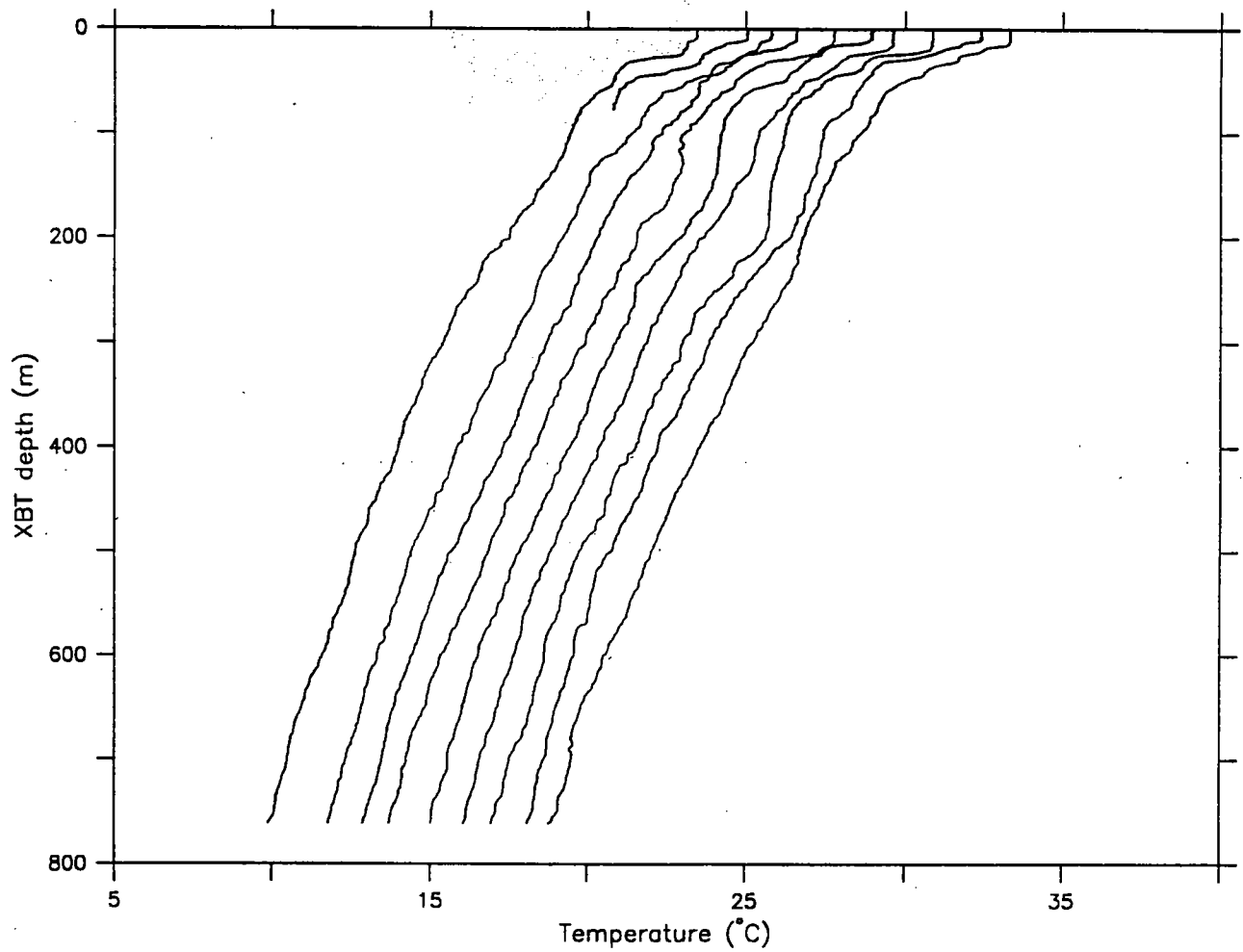

Subduction | XBT start: 220 offset by 1°C

Figure A3-1x. Overplot of XBT Profiles 230-239
Successive Profiles are offset by 1° C.

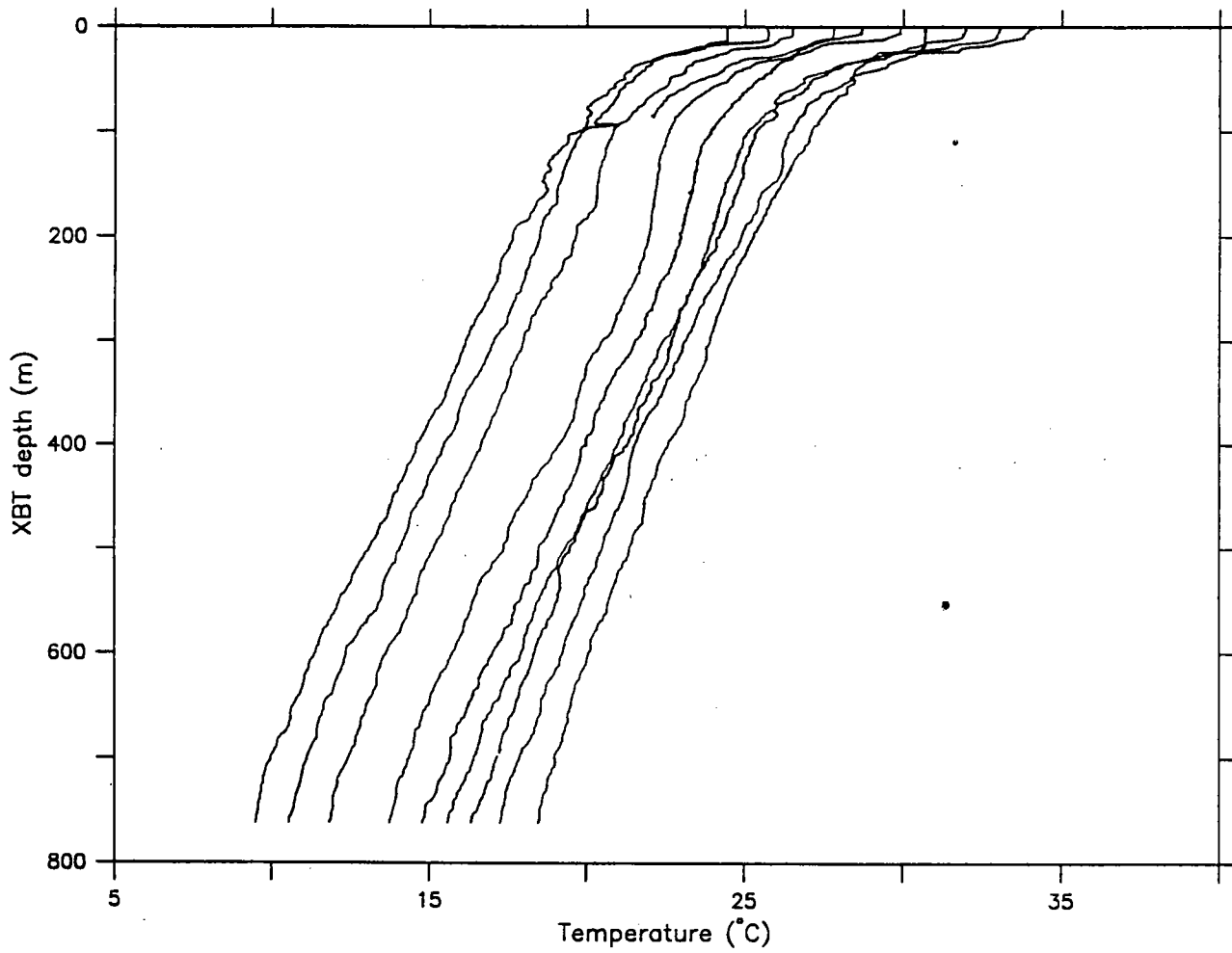

Subduction | XBT start: 230 offset by 1°C

Figure A3-1y. Overplot of XBT Profiles 240-249
Successive Profiles are offset by 1° C.

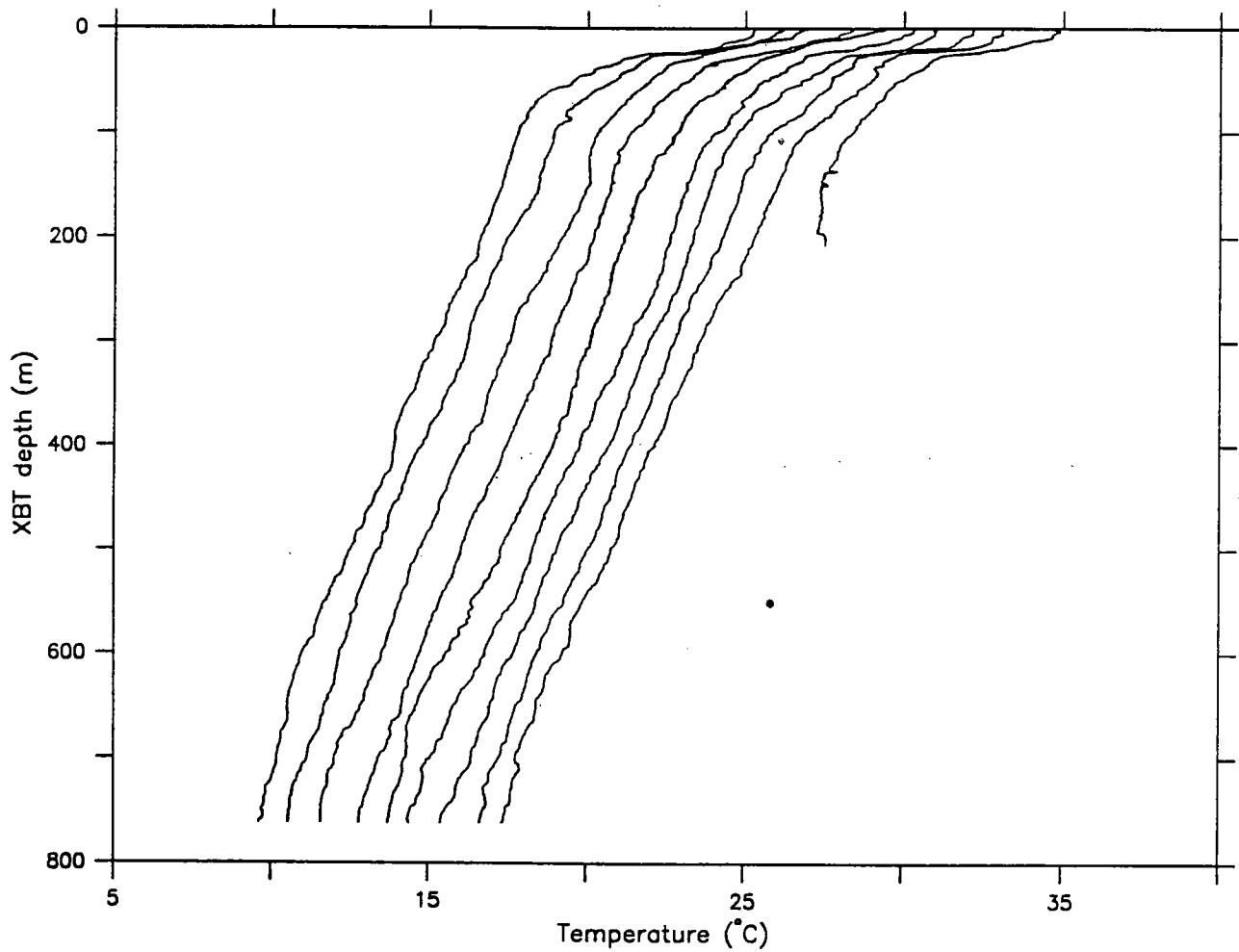

Subduction I XBT start: 240 offset by 1°C

Figure A3-1z. Overplot of XBT Profiles 250-259
Successive Profiles are offset by 1° C.

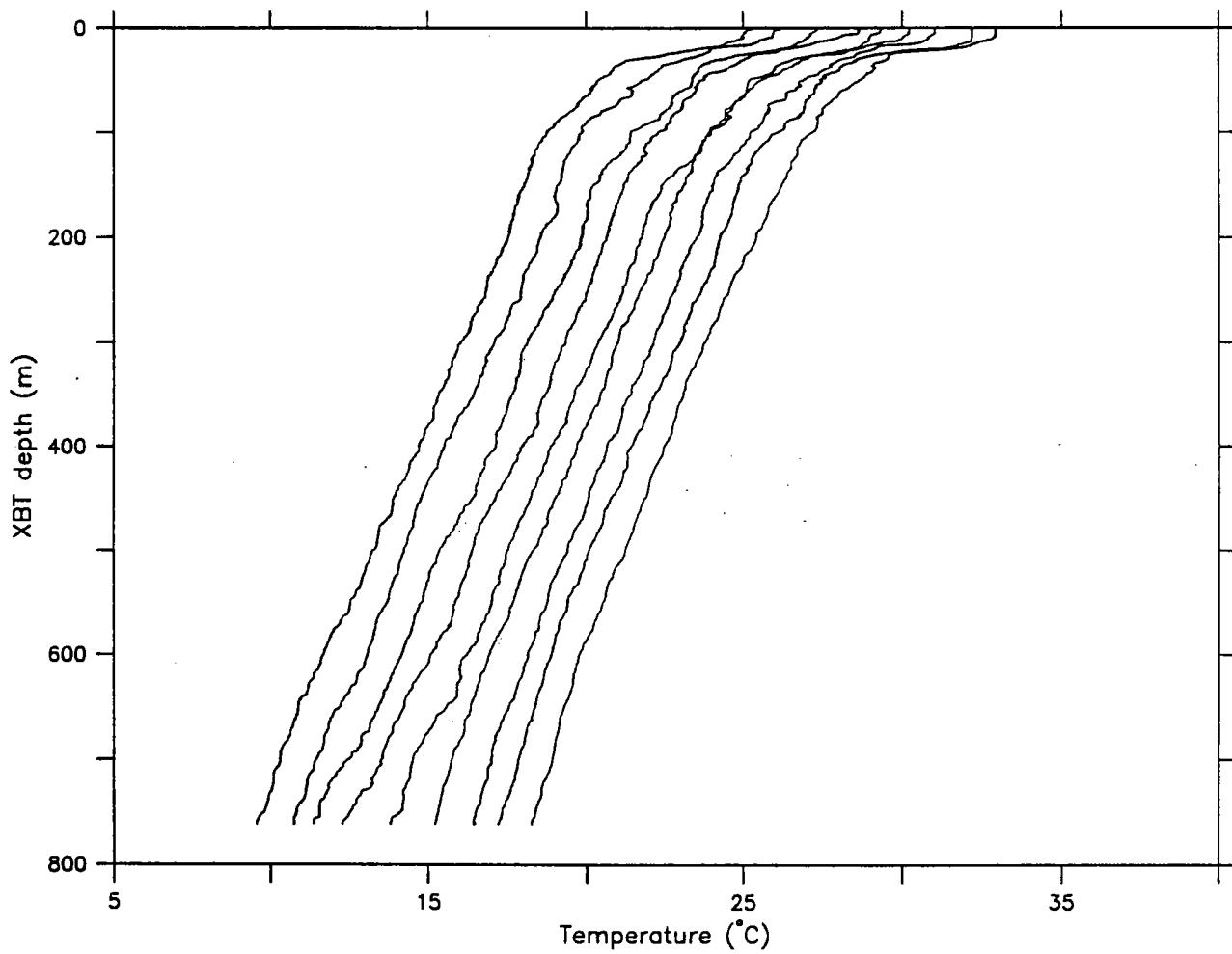

Subduction | XBT start: 250 offset by 1°C

Figure A3-1aa. Overplot of XBT Profiles 260-269
Successive Profiles are offset by 1° C.

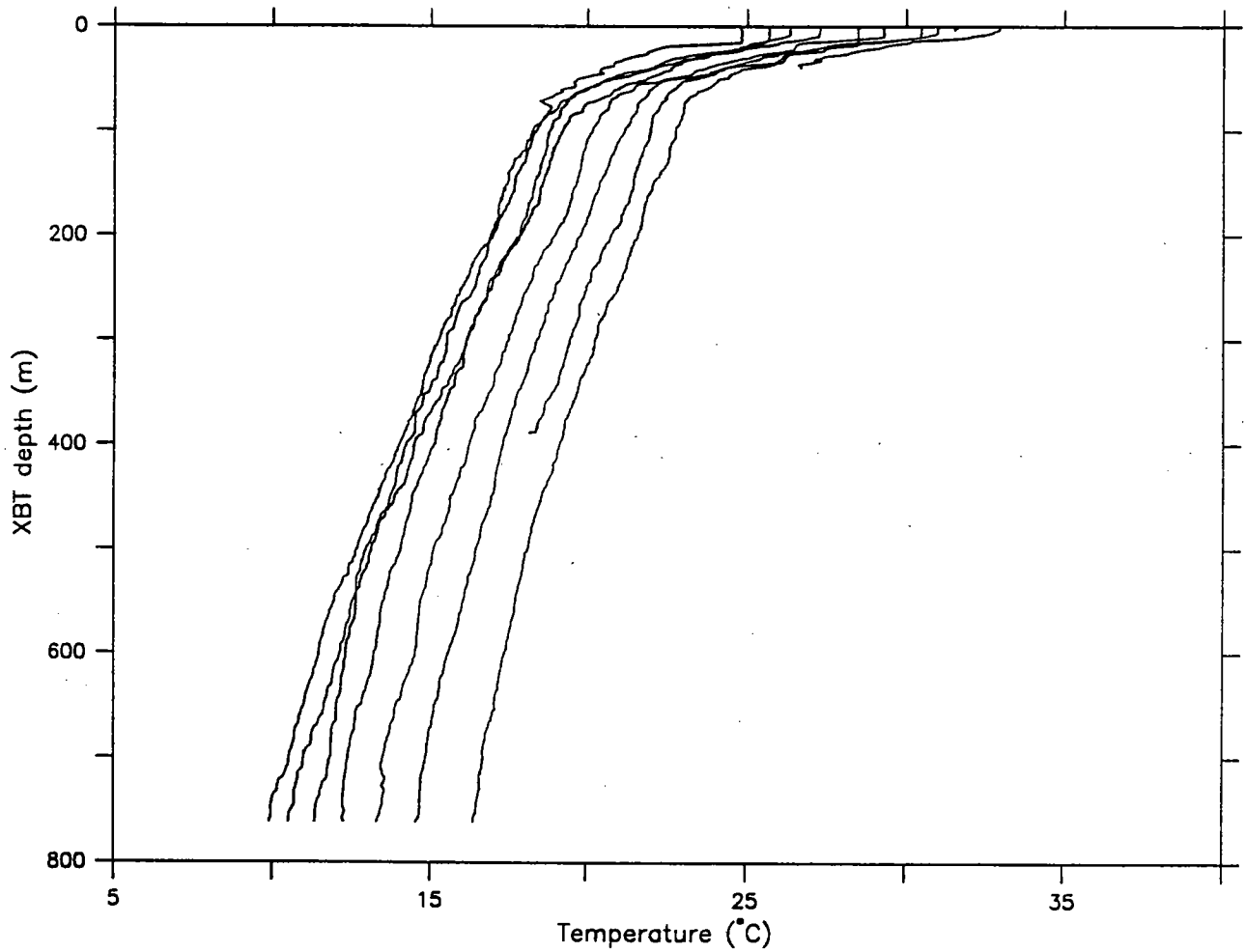

Subduction | XBT start: 260 offset by 1°C

Table A3-1. Positions and Times of XBTs

seq. station	yymmdd date	hhmm time	latitude degrees	longitude degrees	temperature		NODC station
					surface	750m	
0001	910620	0804	31.293	-19.272	21.160	10.710	1
0002	910620	0908	31.172	-19.468	20.520	10.940	2
0003	910620	1005	31.054	-19.652	21.210	10.950	3
0004	910620	1105	30.928	-19.853	20.690	11.070	4
0005	910620	1201	30.818	-20.030	21.010	10.840	5
0006	910620	1238	30.750	-20.123	21.090	10.740	6
0007	910620	1302	30.690	-20.217	21.110	10.880	7
0008	910620	1403	30.570	-20.413	21.300	11.580	8
0009	910620	1500	30.455	-20.602	36.140	12.840	9
0010	910620	1506	30.438	-20.628	21.380	13.080	10
0011	910620	1603	30.336	-20.809	21.200	12.190	11
0012	910620	1701	30.229	-21.003	21.360	11.620	12
0013	910620	1759	30.115	-21.201	21.380	10.950	13
0014	910620	1901	29.992	-21.407	21.290	10.910	14
0015	910620	2002	29.875	-21.604	21.390	10.770	15
0016	910620	2109	29.753	-21.792	21.270	10.520	16
0017	910620	2202	29.652	-21.995	21.240	10.920	17
0018	910620	2312	29.525	-22.197	20.990	10.600	19
0019	910621	0005	29.410	-22.392	21.380	10.770	20
0020	910621	0102	29.290	-22.587	21.140	10.700	21
0021	910621	0201	29.165	-22.778	21.270	10.740	22
0022	910621	0301	29.052	-22.967	21.520	10.380	23
0023	910621	0401	28.937	-23.158	20.970	10.370	24
0024	910621	0503	28.822	-23.369	21.610	10.480	25
0025	910621	0602	28.716	-23.556	21.680	10.730	26
0026	910621	0701	28.606	-23.753	21.720	10.710	27
0027	910621	0802	28.489	-23.952	21.740	10.710	28
0028	910621	0900	28.367	-24.137	22.030	10.270	29
0029	910621	1006	28.255	-24.337	22.130	10.120	31
0030	910621	1104	28.135	-24.527	22.270	10.420	32
0031	910621	1203	28.022	-24.718	22.530	10.720	33
0032	910621	1308	27.890	-24.940	22.470	10.550	34
0033	910621	1403	27.790	-25.097	22.520	10.440	35
0034	910621	1500	27.680	-25.277	22.610	10.220	36
0035	910621	1600	27.562	-25.467	21.540	8.850	37
0036	910621	1700	27.461	-25.674	21.430	9.050	38
0037	910621	1800	27.346	-25.860	21.270	8.840	39
0038	910621	1900	27.234	-26.048	21.660	9.220	40
0039	910621	2003	27.114	-26.238	21.570	8.850	41
0040	910621	2104	26.995	-26.430	21.630	9.120	42
0041	910621	2209	26.872	-26.626	21.750	9.240	44
0042	910621	2306	26.774	-26.791	21.620	9.220	45
0043	910622	0001	26.668	-26.979	21.850	8.750	46
0044	910622	0103	26.559	-27.167	21.720	8.840	47
0045	910622	0202	26.441	-27.373	21.820	8.890	48
0046	910622	0302	26.331	-27.572	21.610	8.590	49
0047	910622	0401	26.225	-27.758	21.910	8.560	50
0048	910622	0501	26.113	-27.960	22.160	8.720	51

0049	910622	0602	26.001	-28.153	22.260	8.640	52
0050	910622	0703	25.890	-28.348	22.280	8.830	53
0051	910622	0801	25.778	-28.534	22.050	8.510	54
0052	910622	0901	25.667	-28.734	22.280	8.420	55
0053	910623	0606	25.336	-29.084	22.410	8.530	56
0054	910623	0701	25.158	-29.207	22.440	8.420	57
0055	910623	0800	24.984	-29.313	22.530	8.590	58
0056	910623	0903	24.804	-29.452	22.440	8.330	59
0057	910623	1001	24.629	-29.569	22.420	8.100	60
0058	910623	1102	24.449	-29.687	22.470	8.590	61
0059	910623	1201	24.270	-29.812	22.500	8.670	62
0060	910623	1304	24.095	-29.933	22.810	8.170	63
0061	910623	1400	23.921	-30.053	22.740	8.070	64
0062	910623	1501	23.740	-30.180	22.660	7.960	65
0063	910623	1520	23.683	-30.218	22.830	7.860	66
0064	910623	1602	23.565	-30.302	22.760	7.610	67
0065	910623	1700	23.392	-30.427	22.580	7.640	68
0066	910623	1805	23.203	-30.565	22.940	7.810	70
0067	910623	1900	23.052	-30.679	23.160	7.740	71
0068	910623	2004	22.869	-30.804	23.080	7.260	72
0069	910623	2102	22.703	-30.909	23.010	6.930	73
0070	910623	2200	22.526	-31.017	23.040	7.470	74
0071	910623	2302	22.385	-31.115	23.240	6.910	75
0072	910623	0002	22.163	-31.213	23.160	7.570	76
0073	910624	0100	21.985	-31.323	23.040	7.290	77
0074	910624	0201	21.810	-31.442	22.820	7.450	78
0075	910624	0300	21.628	-31.567	22.830	7.190	79
0076	910624	0401	21.452	-31.696	22.960	7.430	80
0077	910624	0501	21.273	-31.832	23.000	7.660	81
0078	910624	0600	21.100	-31.957	22.860	7.720	82
0079	910624	0701	20.924	-32.082	22.910	7.640	83
0080	910624	0759	20.754	-32.212	22.800	7.340	84
0081	910624	0900	20.572	-32.334	23.120	7.570	85
0082	910624	1000	20.397	-32.440	23.070	6.880	86
0083	910624	1100	20.225	-32.555	23.210	7.000	87
0084	910624	1201	20.047	-32.665	23.380	7.010	88
0085	910624	1259	19.876	-32.773	23.300	6.750	89
0086	910624	1402	19.693	-32.897	23.400	6.970	90
0087	910624	1459	19.520	-33.011	23.520	6.960	91
0088	910624	1600	19.338	-33.136	23.440	7.050	92
0089	910624	1700	19.156	-33.259	23.530	7.070	93
0090	910624	1800	18.976	-33.384	23.530	6.850	94
0091	910624	1900	18.799	-33.495	23.630	6.900	95
0092	910624	2002	18.621	-33.610	23.660	6.740	96
0093	910624	2101	18.440	-33.725	23.390	6.360	97
0094	910624	2202	18.269	-33.504	23.450	6.460	98
0095	910624	2300	18.095	-33.943	23.480	6.400	99
0096	910626	0910	18.005	-33.743	23.230	6.650	100
0097	910626	1003	18.003	-33.539	23.300	6.360	101
0098	910626	1102	18.002	-33.343	23.230	6.290	102
0099	910626	1201	17.991	-33.137	23.360	6.500	103
0100	910626	1301	17.981	-32.970	23.470	6.640	104
0101	910626	1401	17.971	-32.740	23.330	6.420	105
0102	910626	1500	17.969	-32.540	23.260	6.620	106

0103	910626	1601	17.967	-32.339	23.430	6.960	107
0104	910626	1700	17.974	-32.141	23.450	6.970	108
0105	910626	1800	17.980	-31.940	23.750	6.790	109
0106	910626	1900	17.986	-31.737	23.530	6.790	110
0107	910626	2000	17.989	-31.535	23.520	6.940	111
0108	910626	2102	18.002	-31.319	23.520	6.910	112
0109	910626	2202	17.998	-31.109	23.424	6.760	113
0110	910626	2304	17.996	-30.906	23.570	6.810	114
0111	910626	0000	17.996	-30.712	23.320	7.010	115
0112	910627	0101	18.005	-30.510	23.460	6.740	116
0113	910627	0207	18.012	-30.308	23.290	6.740	117
0114	910627	0302	18.008	-30.108	23.220	6.590	118
0115	910627	0401	17.999	-29.913	23.130	6.770	119
0116	910627	0503	17.991	-29.704	22.990	6.690	120
0117	910627	0601	17.987	-29.510	23.100	6.830	121
0118	910627	0702	17.984	-29.302	22.940	6.890	122
0119	910627	0801	17.983	-29.097	23.110	6.830	123
0120	910627	0902	17.981	-28.894	23.120	6.900	124
0121	910627	1003	17.983	-28.680	22.900	6.850	125
0122	910627	1102	17.985	-28.487	22.770	6.930	126
0123	910627	1202	17.983	-28.282	22.730	6.840	127
0124	910627	1301	17.980	-28.078	22.840	6.830	128
0125	910627	1402	17.977	-27.882	22.970	6.790	130
0126	910627	1500	17.967	-27.677	23.230	6.960	130
0127	910627	1600	17.967	-27.470	23.060	6.910	131
0128	910627	1700	17.971	-27.268	23.450	6.790	132
0129	910627	1800	17.977	-27.067	23.440	6.620	133
0130	910627	1900	17.988	-26.865	23.510	6.980	134
0131	910627	2000	18.002	-26.666	23.070	6.760	135
0132	910627	2110	18.015	-26.405	23.210	6.800	138
0133	910627	2202	18.017	-26.244	23.250	7.050	139
0134	910627	2300	18.014	-26.042	22.930	6.980	140
0135	910627	2359	18.002	-25.837	23.020	6.880	141
0136	910628	0100	17.996	-25.622	22.780	6.810	142
0137	910628	0200	17.996	-25.408	22.720	6.840	143
0138	910628	0300	17.996	-25.198	22.680	7.010	144
0139	910628	0410	17.996	-24.987	22.740	6.920	147
0140	910628	0500	17.995	-24.782	22.690	7.060	148
0141	910628	0600	17.996	-24.572	22.600	7.150	149
0142	910628	0700	17.997	-24.359	22.500	7.080	150
0143	910628	0801	18.000	-24.143	22.450	7.110	151
0144	910628	0902	17.997	-23.928	22.320	7.080	152
0145	910628	1010	17.997	-23.715	22.420	6.850	153
0146	910628	1101	18.002	-23.499	22.390	6.980	154
0147	910628	1159	17.993	-23.292	22.200	7.020	155
0148	910628	1300	17.993	-23.080	22.300	6.870	156
0149	910628	1401	17.990	-22.867	22.490	6.970	157
0150	910628	1501	17.988	-22.660	22.100	7.080	158
0151	910628	1601	17.986	-22.453	22.170	6.850	159
0152	910628	1700	17.986	-22.248	22.280	6.810	160
0153	910629	0701	18.118	-22.150	21.840	6.930	161
0154	910629	0804	18.261	-22.274	21.790	7.140	162
0155	910629	0901	18.367	-22.383	21.900	7.220	163
0156	910629	1001	18.501	-22.500	21.930	6.890	164

0157	910629	1059	18.634	-22.561	22.360	7.050	165
0158	910629	1201	18.767	-22.752	22.300	7.120	166
0159	910629	1304	18.912	-22.882	22.280	6.920	167
0160	910629	1401	19.033	-23.003	22.330	7.160	168
0161	910629	1500	19.177	-23.139	22.380	6.880	169
0162	910629	1602	19.341	-23.288	22.290	6.800	170
0163	910629	1701	19.499	-23.436	22.460	7.250	171
0164	910629	1803	19.666	-23.592	22.580	7.120	172
0165	910629	1900	19.820	-23.822	22.540	7.250	173
0166	910629	2000	19.988	-23.882	22.480	7.160	174
0167	910629	2103	20.157	-24.043	22.410	7.070	175
0168	910629	2201	20.311	-24.182	22.420	7.450	176
0169	910629	2301	20.487	-24.333	21.990	7.030	177
0170	910630	0001	20.644	-24.480	22.240	6.830	178
0171	910630	0101	20.806	-24.625	22.250	7.380	179
0172	910630	0201	20.967	-24.777	22.170	7.270	180
0173	910630	0301	21.130	-24.928	22.240	6.990	181
0174	910630	0404	21.296	-25.087	22.190	7.180	182
0175	910630	0503	21.471	-25.236	22.310	7.370	183
0176	910630	0603	21.647	-25.381	22.470	7.420	184
0177	910630	0704	21.793	-25.540	22.410	7.390	185
0178	910630	0801	21.953	-25.687	22.360	7.330	186
0179	910630	0858	22.100	-25.820	22.340	7.570	187
0180	910630	1059	22.419	-26.114	22.410	8.020	189
0181	910630	1201	22.576	-26.267	22.280	7.580	190
0182	910630	1302	22.733	-26.417	22.460	7.810	191
0183	910630	1401	22.891	-26.560	22.530	7.660	192
0184	910630	1501	23.052	-26.702	22.610	7.970	193
0185	910630	1603	23.215	-26.840	22.490	7.650	194
0186	910630	1703	23.377	-26.989	22.550	7.910	195
0187	910630	1803	23.542	-27.152	22.480	8.090	196
0188	910630	1902	23.696	-27.306	22.180	8.180	197
0189	910630	2002	23.855	-27.459	22.270	8.070	198
0190	910630	2100	24.022	-27.608	22.340	8.320	199
0191	910630	2200	24.189	-27.754	22.320	8.250	200
0192	910630	2259	24.345	-27.897	22.190	7.900	201
0193	910701	0001	24.508	-28.050	22.340	8.200	202
0194	910701	0101	24.662	-28.201	22.400	8.050	203
0195	910701	0202	24.816	-28.348	22.430	8.380	204
0196	910701	0301	24.973	-28.491	22.370	8.600	205
0197	910701	0402	25.131	-28.630	22.330	8.330	206
0198	910701	0503	25.302	-28.772	22.500	8.460	207
0199	910701	0901	25.780	-29.137	22.840	8.540	208
0200	910701	1001	25.956	-29.260	22.840	8.430	209
0201	910701	1101	26.137	-29.378	22.860	8.840	210
0202	910701	1201	26.326	-29.504	22.810	9.180	211
0203	910701	1300	26.510	-29.625	22.560	8.930	212
0204	910701	1402	26.692	-29.750	22.850	8.970	213
0205	910701	1500	26.875	-29.876	22.960	9.060	214
0206	910701	1603	27.071	-30.002	23.130	9.100	215
0207	910701	1702	27.247	-30.124	23.360	9.180	216
0208	910701	1804	27.446	-30.236	23.370	9.000	217
0209	910701	1902	27.629	-30.346	23.380	8.810	218
0210	910701	2000	27.813	-30.455	23.750	8.910	219

0211	910701	2100	27.995	-30.570	23.470	9.640	220
0212	910701	2301	28.361	-30.806	23.840	9.550	222
0213	910702	0001	28.546	-30.933	23.550	9.520	223
0214	910702	0102	28.728	-31.058	23.780	9.450	224
0215	910702	0200	28.901	-31.177	23.900	9.580	225
0216	910702	0301	29.082	-31.300	23.610	9.710	226
0217	910702	0403	29.263	-31.425	23.890	9.680	227
0218	910702	0505	29.436	-31.542	24.430	9.850	228
0219	910702	0603	29.606	-31.663	24.310	9.510	229
0220	910702	0706	29.783	-31.794	24.430	9.330	230
0221	910702	0802	29.981	-31.908	24.690	9.250	231
0222	910702	0905	30.165	-32.020	24.540	9.390	232
0223	910702	1006	30.354	-32.151	24.770	9.470	234
0224	910702	1107	30.585	-32.289	24.940	9.540	235
0225	910702	1201	30.738	-32.402	24.750	9.320	236
0226	910702	1301	30.933	-32.520	24.980	9.100	237
0227	910702	1400	31.112	-32.626	25.110	9.130	238
0228	910702	1500	31.289	-32.753	25.080	9.310	239
0229	910702	1603	31.470	-32.892	25.320	9.250	240
0230	910702	1704	31.655	-33.029	25.160	9.130	241
0231	910702	1806	31.833	-33.179	24.890	9.350	242
0232	910702	1903	32.013	-33.320	25.450	9.240	243
0233	910702	2000	32.181	-33.439	25.500	9.530	244
0234	910702	2058	32.353	-33.595	25.230	9.380	245
0235	910702	2200	33.547	-33.694	24.930	9.140	246
0236	910702	2300	32.735	-33.826	25.130	9.200	247
0237	910703	0000	32.935	-33.950	25.090	8.930	248
0238	910703	1706	33.059	-33.675	25.260	9.120	250
0239	910703	1800	33.171	-33.498	25.300	9.290	251
0240	910703	1859	33.284	-33.284	25.320	8.780	252
0241	910703	2002	33.414	-33.082	25.690	8.800	253
0242	910703	2100	33.532	-32.892	25.350	9.430	254
0243	910703	2201	33.651	-32.687	34.580	9.750	255
0244	910703	2303	33.772	-32.483	25.230	9.880	256
0245	910704	0002	33.893	-32.283	25.000	9.850	257
0246	910704	0102	34.017	-32.077	25.200	9.880	258
0247	910704	0200	34.137	-31.873	24.910	9.970	259
0248	910704	0258	34.253	-31.667	24.820	9.570	260
0249	910704	0401	34.374	-31.440	24.650	9.370	261
0250	910704	0500	34.491	-31.229	24.400	8.850	262
0251	910704	0601	34.609	-30.997	24.280	9.170	263
0252	910704	0700	34.737	-30.775	24.490	9.130	264
0253	910704	0804	34.875	-30.566	24.300	9.350	265
0254	910704	0901	35.009	-30.364	24.430	9.170	266
0255	910704	1002	35.141	-30.152	24.040	9.270	267
0256	910704	1104	35.262	-29.950	23.670	9.580	268

Figure A3-2 a, b, c, d
 XBT positions on ship track, contoured temperature at 0, 200 and 500m.

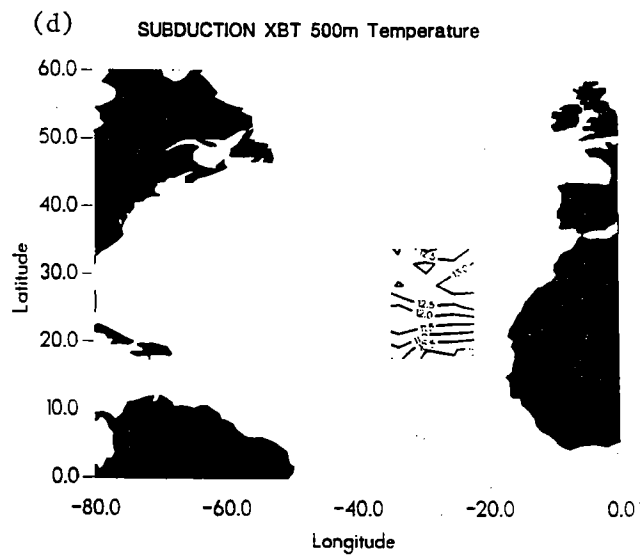
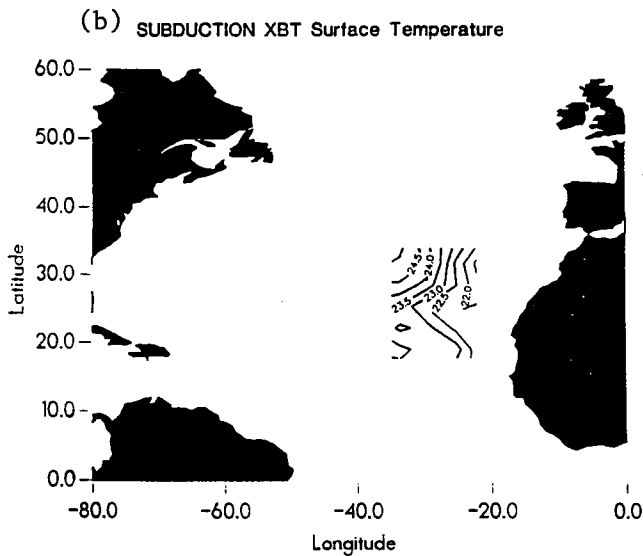
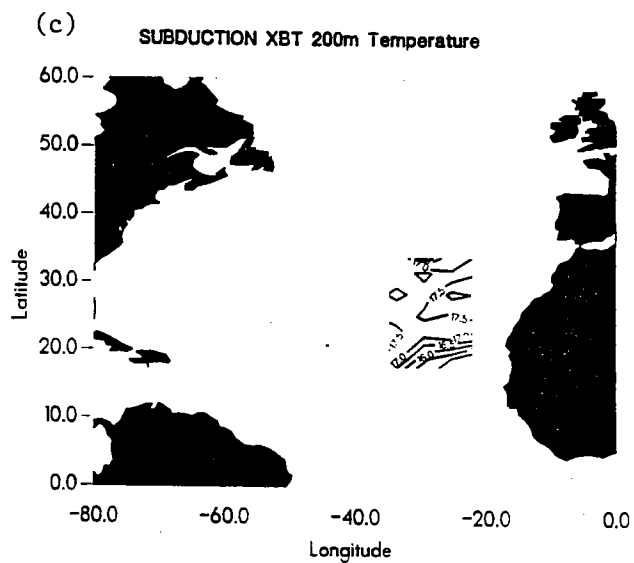
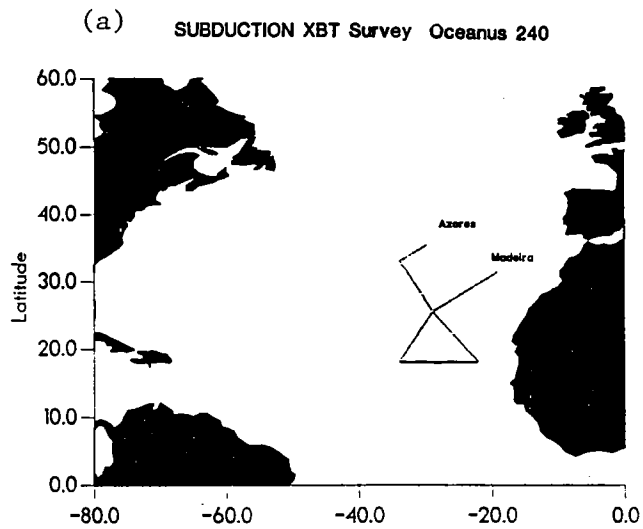

Figure A3-3. XBT section locations

Section a	XBTs 1-52
b	XBTs 53-95
c	XBTs 96-152
d	XBTs 153-198
e	XBTs 199-237
f	XBTs 238-255

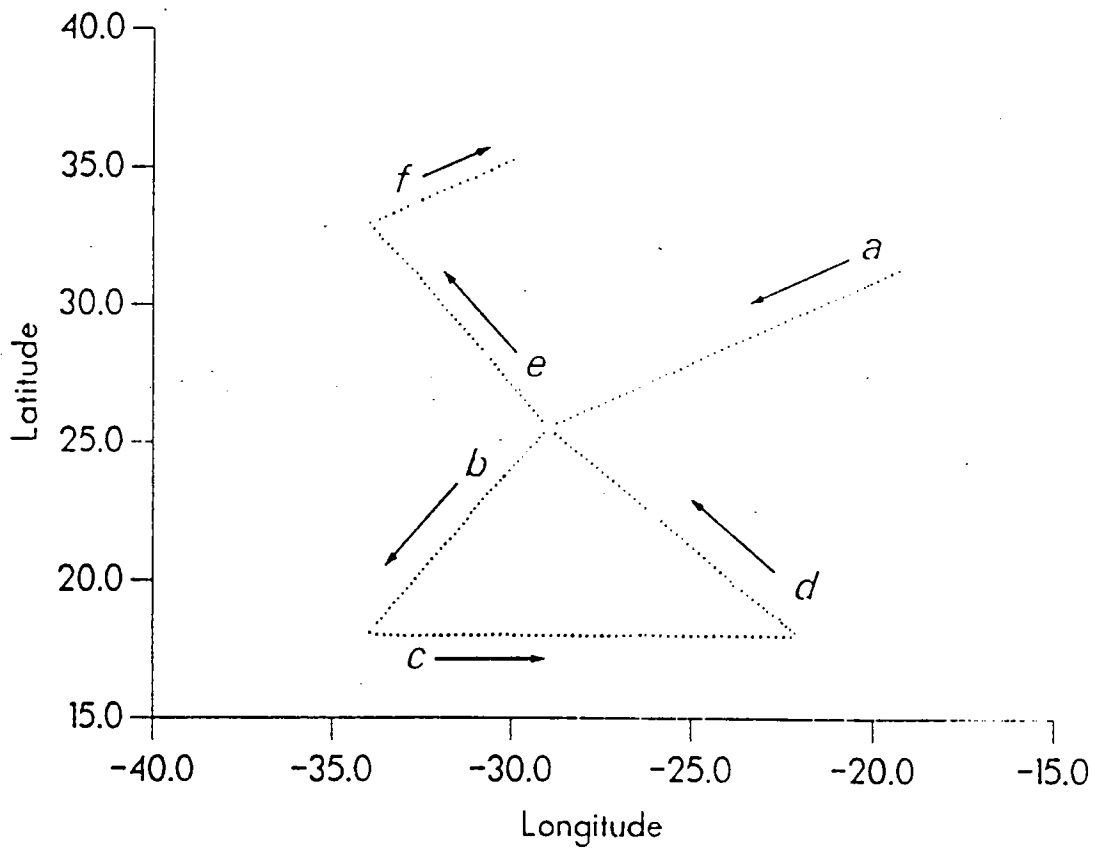
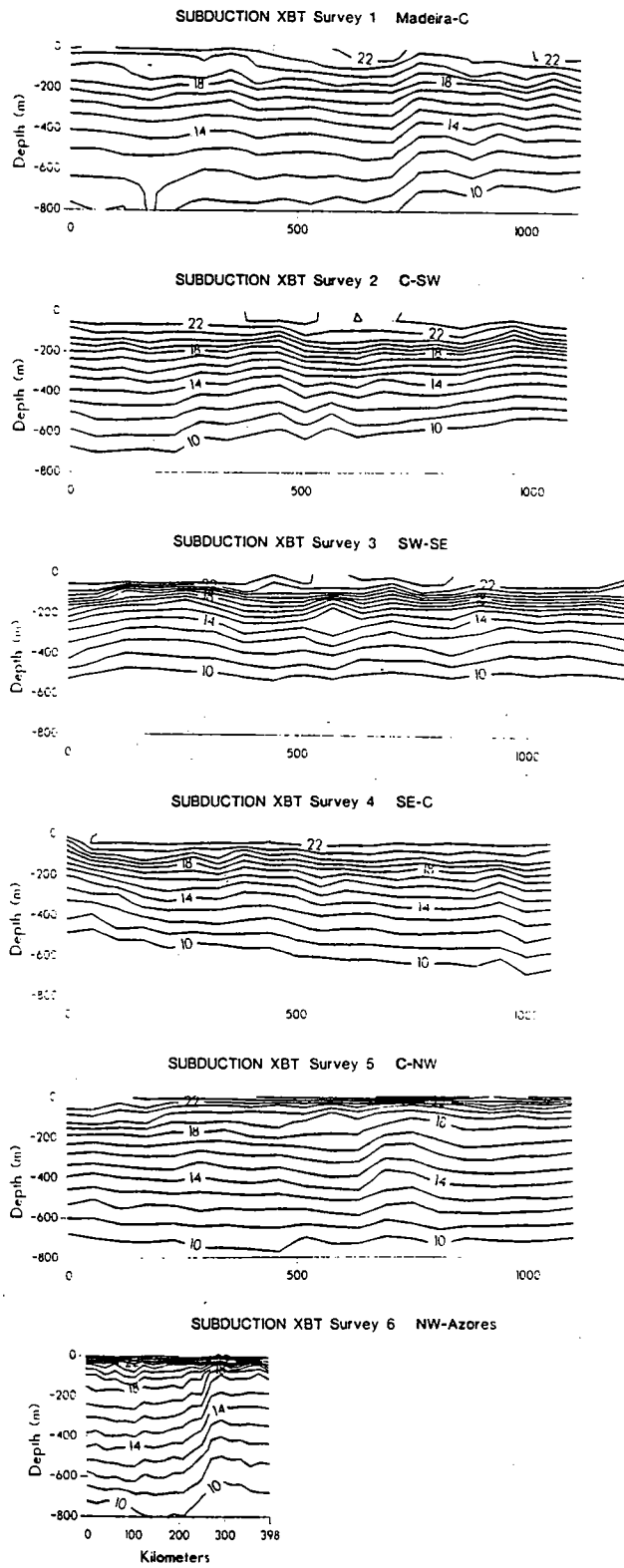

Figure A3-4. Contoured XBT Section Data



Appendix 4

Abridged Chronological Log

17 June

0714 Oceanus sails

1000 Underway watch begins
Weather is uneventful - various amounts of stratocumulus clouds along transit with some taller cumulus clouds in patches

1600 Fire and Boat Drill

18 June

0403 Bottom survey started for Mooring 914 (NE corner) of Subduction/ASTEX array
0613 Survey completed - proposed site depth 5264m

0627 Release test 32 54.655°N 22 00.063°W

0940 Mooring 914 begun Buoy in water
1640 Anchor drop

1700-1945 Anchor Survey Mooring 914 Anchor Position 33 00.07°N 21 59.75°W

1840-1915 Meteorological Comparison between buoy and ship sensors holding position about 1/4 mile downwind of buoy

1947 Underway to Madeira to pick up remaining buoy and mooring hardware

19 June

1530 Suspend underway watch

1635-2000 In Port, SE buoy tower hit with cages while loading gear. VAWR and solar panel damaged.

1956 Oceanus sails heading for Central mooring site.

2100 Resume underway met watch

20 June

0800 Continuing half hour met watch and begin hourly XBT

21 June

22 June

0956 Bottom survey started for Mooring 915 (Central)
1200 Survey completed - proposed depth site 5673m

1222-1350 Release test

1520 Mooring 915 begun Buoy in water

23 June

0027 Anchor drop

23 June
0135-204 Hydrographic station for Jim Ledwell. Bottles at 50,100,150,200,250,300,350,
400,450
Position 25 32.817°N 28 55.498°W

0205-0341 Anchor Survey Mooring 915 Anchor Position 25 31.90°N 28 57.17°W

0415-0445 Meteorological Comparison between buoy and ship sensors
Ship stationed approx. 1/4 mile downwind

0605 Resume underway met and XBT watch

24 June
1400 Stop at Mail Buoy

2300 Suspend underway watch

2220-
25 June
0100 Bottom survey started for Mooring 916 (SW)
Survey completed - proposed depth 5300m

0140-0332 Release test

0506 Mooring 916 begun Buoy in water

1312 Anchor over
Buoy submerged for approx. 1.5 minutes before settling out
Hove to until morning to check out meteorological sensors

1737-1943 Anchor Survey Mooring 916 Anchor Position 18 00.033°N 33 00.95°W

1620-1655 Meteorological Comparison between buoy and ship sensors
Ship stationed 1/4 mile downwind.

2000 Meteorological watch resumed

26 June
0740 Underway to SE Mooring site

0900 Resume underway met and XBT watch

27 June

28 June

1731 Bottom Survey started for Mooring 917 (SE)
1946 Survey completed proposed depth 3295m

1930 Suspend underway watch

2027 Mooring 917 begun Buoy in water

29 June
0137 Anchor over

0215-0310 Meteorological Comparison between buoy and ship sensors
Ship stationed 1/4 mile downwind
VAWR wind direction is off 90-100°

29 June

0437-0550 Anchor Survey Mooring 917 Anchor Position 18 00.13°N 22 00.00°W

0558 Underway to Central Mooring for visual inspection on way to NW Mooring site

0700 Resume underway met and XBT survey

30 June

1 July

0500 Suspend underway watch

0620 Arrive at Central Mooring

0630-0715 Meteorological comparison of buoy and ship sensors

0730 Underway to NW mooring site

0900 Resume underway met and XBT survey

2 July

3 July

0000 Suspend underway watch

0015-0359 Bottom survey
Topography very irregular target position changed
Proposed site 3607 m 32 54.30°N 33 53.30°W

0442-0550 Release test

0722 Mooring 918 begun Buoy over

1323 Anchor over

1355-1425 Meteorological comparison between mooring and ship sensors
Ship stationed 1/4 mile downwind

1433-1600 Anchor survey Mooring 918 Anchor Position 32 54.61°N 33 53.50°W

1605 Underway to the Azores

1700 Resume underway met and XBT watch

4 July

5 July

0828 Arrive Ponta Delgada

DOCUMENT LIBRARY

February 5, 1993

Distribution List for Technical Report Exchange

University of California, San Diego
SIO Library 0175C (TRC)
9500 Gilman Drive
La Jolla, CA 92093-0175

Hancock Library of Biology &
Oceanography
Alan Hancock Laboratory
University of Southern California
University Park
Los Angeles, CA 90089-0371

Gifts & Exchanges
Library
Bedford Institute of Oceanography
P.O. Box 1006
Dartmouth, NS, B2Y 4A2, CANADA

Office of the International
Ice Patrol
c/o Coast Guard R & D Center
Avery Point
Groton, CT 06340

NOAA/EDIS Miami Library Center
4301 Rickenbacker Causeway
Miami, FL 33149

Library
Skidaway Institute of Oceanography
P.O. Box 13687
Savannah, GA 31416

Institute of Geophysics
University of Hawaii
Library Room 252
2525 Correa Road
Honolulu, HI 96822

Marine Resources Information Center
Building E38-320
MIT
Cambridge, MA 02139

Library
Lamont-Doherty Geological
Observatory
Columbia University
Palisades, NY 10964

Library
Serials Department
Oregon State University
Corvallis, OR 97331

Pell Marine Science Library
University of Rhode Island
Narragansett Bay Campus
Narragansett, RI 02882

Working Collection
Texas A&M University
Dept. of Oceanography
College Station, TX 77843

Fisheries-Oceanography Library
151 Oceanography Teaching Bldg.
University of Washington
Seattle, WA 98195

Library
R.S.M.A.S.
University of Miami
4600 Rickenbacker Causeway
Miami, FL 33149

Maury Oceanographic Library
Naval Oceanographic Office
Stennis Space Center
NSTL, MS 39522-5001

Marine Sciences Collection
Mayaguez Campus Library
University of Puerto Rico
Mayaguez, Puerto Rico 00708

Library
Institute of Oceanographic Sciences
Deacon Laboratory
Wormley, Godalming
Surrey GU8 5UB
UNITED KINGDOM

The Librarian
CSIRO Marine Laboratories
G.P.O. Box 1538
Hobart, Tasmania
AUSTRALIA 7001

Library
Proudman Oceanographic Laboratory
Bidston Observatory
Birkenhead
Merseyside L43 7 RA
UNITED KINGDOM

IFREMER
Centre de Brest
Service Documentation - Publications
BP 70 29280 PLOUZANE
FRANCE

REPORT DOCUMENTATION PAGE	1. REPORT NO. WHOI-93-12	2.	3. Recipient's Accession No.
4. Title and Subtitle The Subduction Experiment – Cruise Report – R/V <i>Oceanus</i> – Cruise Number 240 Leg 3 – Subduction 1 Mooring Deployment Cruise		5. Report Date March 1993	
7. Author(s) Richard P. Trask and Nancy J. Brink		8. Performing Organization Rept. No. WHOI 93-12	
9. Performing Organization Name and Address The Woods Hole Oceanographic Institution Woods Hole, Massachusetts 02543		10. Project/Task/Work Unit No.	
12. Sponsoring Organization Name and Address Funding was provided by the Office of Naval Research.		11. Contract(C) or Grant(G) No. (C) N00014-90-J-1490 (G)	
15. Supplementary Notes This report should be cited as: Woods Hole Oceanog. Inst. Tech. Rept., WHOI-93-12.		13. Type of Report & Period Covered Technical Report	
16. Abstract (Limit: 200 words) <p>Subduction is the mechanism by which water masses formed in the mixed layer and near the surface of the ocean find their way into the upper thermocline. The subduction process and its underlying mechanisms were studied through a combination of Eulerian and Lagrangian measurements of velocity, measurements of tracer distributions and hydrographic properties and modeling.</p> <p>An array of five surface moorings carrying meteorological and oceanographic instrumentation were deployed for a period of two years beginning in June 1991 as part of an Office of Naval Research (ONR) funded Subduction experiment. Three eight month deployments were planned. The initial deployment of five surface moorings took place during the third leg of R/V <i>Oceanus</i> cruise number 240. The moorings were deployed at 18°N 34°W, 18°N 22°W, 25.5°N 29°W, 33°N 22°W and 33°N 34°W.</p> <p>A Vector Averaging Wind Recorder (VAWR) and an Improved Meteorological Recorder (IMET) collected wind speed and wind direction, sea surface temperature, air temperature, short wave radiation, long wave radiation, barometric pressure and relative humidity. The IMET also measured precipitation. The moorings were heavily instrumented below the surface with Vector Measuring Current Meters (VMCM) and single point temperature recorders.</p> <p>Expendable bathythermograph (XBT) data were collected and meteorological observations were made while transiting between mooring locations.</p> <p>This report describes the work that took place during R/V <i>Oceanus</i> cruise 240 leg 3. It includes a description of the instrumentation that was deployed, information about the XBT data collected and plots of the data as well as a chronology of the cruise events.</p>		14.	
17. Document Analysis a. Descriptors			
1. air-sea interaction			
2. moored instruments			
3. subduction			
b. Identifiers/Open-Ended Terms			
c. COSATI Field/Group			
18. Availability Statement Approved for publication; distribution unlimited.		19. Security Class (This Report) UNCLASSIFIED	21. No. of Pages 81
		20. Security Class (This Page)	22. Price

