

WHOI-95-12

COPY 1

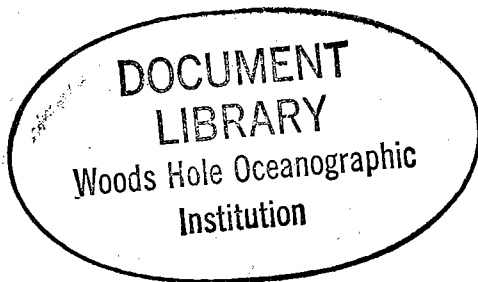

Woods Hole Oceanographic Institution



Report of a Workshop on Technical Approaches to Construction of a Seafloor Geomagnetic Observatory

by

Alan D. Chave (co-chair; Woods Hole Oceanographic Institution)

Arthur W. Green, Jr. (co-chair; US Geological Survey)

Rob L. Evans (Woods Hole Oceanographic Institution)

Jean H. Filloux (Scripps Institution of Oceanography)

Lawrie K. Law (Geological Survey of Canada)

Robert A. Pettitt, Jr. (Woods Hole Oceanographic Institution)

Jean L. Rasson (Institut Royal Meteorologique, Belgium)

Adam Schultz (University of Cambridge)

Fred N. Spiess (Scripps Institution of Oceanography)

Pascal Tarits (Université de Bretagne Occidentale)

Maurice Tivey (Woods Hole Oceanographic Institution)

Spahr C. Webb (Scripps Institution of Oceanography)

September 1995

Technical Report

Funding was provided by the National Science Foundation under grant EAR94-21712 and the National Aeronautics and Space Administration.

Approved for public release; distribution unlimited.

WHOI-95-12

Report of a Workshop on Technical Approaches to Construction of a Seafloor
Geomagnetic Observatory

by

DOCUMENT
LIBRARY
Woods Hole Oceanographic
Institution

Alan D. Chave (co-chair; Woods Hole Oceanographic Institution)
Arthur W. Green, Jr. (co-chair; US Geological Survey)
Rob L. Evans (Woods Hole Oceanographic Institution)
Jean H. Filloux (Scripps Institution of Oceanography)
Lawrie K. Law (Geological Survey of Canada)
Robert A. Petitt, Jr. (Woods Hole Oceanographic Institution)
Jean L. Rasson (Institut Royal Meteorologique, Belgium)
Adam Schultz (University of Cambridge)
Fred N. Spiess (Scripps Institution of Oceanography)
Pascal Tarits (Université de Bretagne Occidentale)
Maurice Tivey (Woods Hole Oceanographic Institution)
Spahr C. Webb (Scripps Institution of Oceanography)

Woods Hole Oceanographic Institution
Woods Hole, Massachusetts 02543

September 1995

Technical Report

Funding was provided by the National Science Foundation under grant EAR94-21712 and the
National Aeronautics and Space Administration.

Reproduction in whole or in part is permitted for any purpose of the United States Government.
This report should be cited as Woods Hole Oceanog. Inst. Tech. Rept., WHOI-95-12.

Approved for public release; distribution unlimited.

Approved for Distribution:

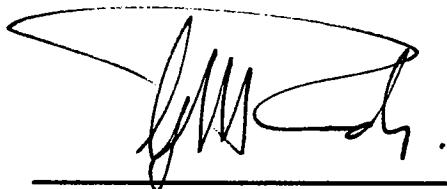

G. Michael Purdy, Chair
Department of Geology and Geophysics



Table of Contents

Executive Summary	2
A. Introduction	3
B. The Scientific Rationale for Seafloor Observatories	3
C. Terrestrial Geomagnetic Observatories	5
D. The Seafloor Environment	7
E. The Components of a Seafloor Observatory	9
1. Sensor Components	10
a. Vector Magnetometer Sensors	10
b. Absolute Intensity Sensors	12
c. Absolute Direction Measurement	13
d. Tilt sensors	18
e. Electric Field Sensors	19
2. Data Recording and Transmission	19
3. Observatory Timing and Control	21
4. Power	22
5. Observatory Packaging	24
F. Logistical Issues	26
G. A Conceptual Seafloor Observatory Design	27
References	30
Figure Captions	32

Executive Summary

In 1994, a Geomagnetic Observatory Task Group was formed by the US Geodynamics Committee and charged with examining the status and possible enhancement of the global geomagnetic observatory network. Their report addressed the scientific benefits of expanding the observatory base, and in particular proposed the installation of 40 new observatories, of which 8 would be located on the seafloor in areas where land sites are not feasible. They also recommended that a workshop be convened to examine the technical feasibility of constructing permanent geomagnetic observatories on the seafloor. This meeting was held in November 1994 in Woods Hole.

The workshop participants considered the technical issues with respect to sensors, data recording and transmission, observatory control and timing, power, and packaging. It was quickly concluded that existing technologies either already in use for oceanographic purposes or adapted from terrestrial geomagnetic observatories could be applied to measure the vector magnetic field components and absolute intensity with minimal development. The major technical challenge arises in measuring absolute direction on the seafloor because terrestrial techniques are based on optical surveying, and hence not transferrable to the deep ocean. Two different approaches to solving this problem were identified. The first of these requires the construction of an absolute declination-inclination fluxgate instrument which measures the instantaneous declination and inclination of the magnetic field relative to a north-seeking gyroscope and the local vertical. This will require a major, multiple year development effort, but has applications on both land and in the ocean, and in particular would allow the total automation of terrestrial geomagnetic observatories. The second approach is a relatively straightforward extension of a precision acoustic method for determining absolute position on the seafloor that would yield the absolute direction of acoustic transponder baselines with very high accuracy. A seafloor slab containing vector sensors can be navigated relative to this baseline using optical methods and hence can be oriented relative to true north. This method requires no major technical developments, and an observatory based on acoustic direction measurement could be emplaced relatively quickly. As a scientific bonus, an acoustic direction system serves as a major component of a geodetic observatory.

The remaining technical issues do not present any major obstacles. The data storage requirements for geomagnetic data are modest (a few megabytes per year) and can easily be stored *in situ* and transferred to a surface ship using existing acoustic modem technology. Observatory timing can be provided by a simple quartz clock and control by a central computer is easily accomplished. Power consumption of a geomagnetic observatory can be kept below 1 watt, and hence long term (five year) operation using lithium batteries is feasible. Observatory packaging must ensure compatibility with the submersible assets which will be required for their installation and provide long term corrosion protection.

A conceptual design for a seafloor geomagnetic observatory is outlined, and could be installed two years after initial funding. The cost for the instrumentation at an observatory would be US\$400-500K, not including installation. Engineering development costs for the first observatory will probably be comparable. Such an observatory would have a lifetime of five years between major servicing, and is intended to be permanent.

Co-location of seafloor geomagnetic observatories with other types of long term ocean instrumentation offers major logistical advantages, and should be considered to minimize costs.

A. Introduction

Following on a major recommendation of the *National Geomagnetic Initiative* [1993] report of the National Research Council and at the request of the US Geodynamics Committee, a Geomagnetic Observatory Task Group was organized and charged with examining the status and possible enhancement of the global geomagnetic observatory network. Their report [*Geomagnetic Observatory Task Group*, 1994] addressed the scientific rationale for expanding the geomagnetic observatory network, and in particular making their distribution on the globe more even. They concluded that this will inevitably require the installation of some observatories on the seafloor, as the density of continents and islands varies markedly with location on Earth. One of the Task Group's principal recommendations was that a workshop be convened to conceptually design a seafloor geomagnetic observatory that meets full terrestrial observatory specifications, including absolute controls, and to consider where a prototype observatory might first be deployed. Under the joint sponsorship of the National Science Foundation and the National Aeronautics and Space Administration, a small meeting on this subject was held in Woods Hole, Massachusetts, in November 1994. This document is the report of the workshop.

B. The Scientific Rationale for Seafloor Observatories

A location map of the roughly 200 geomagnetic observatories that exist or have existed since the late 1800's (Figure 1) makes it clear that their distribution on the globe is quite uneven. As documented in *Geomagnetic Observatory Task Group* [1994], the data coverage is inadequate to record the large scale characteristics of the geomagnetic field, and is a source of bias in studies of the main field, its secular variation, and the deep conductivity of the earth. Complete lists of past and present geomagnetic observatories may be found in *McLean et al.* [1994] and *Geomagnetic Observatory Task Group* [1994].

The skewed observatory distribution is due to several causes. First, the number of recording stations has grown without any overall international agreement or guidelines, and typically reflects the location of developed nations with a sufficient scientific and economic base to support geomagnetic observations. The very heavy concentration of observatories in Europe is due to a long tradition of studying the geomagnetic field in that region, and the paucity of stations in Africa reflects the financial difficulty of supporting such activities. Second, many observatories were established before there was a clear idea of the causes of geomagnetic phenomena and the relevant scales over which they vary. This led to the installation of observatories where they could conveniently be monitored rather than where they are now known to be most scientifically useful. Third, seventy percent of Earth's surface is covered by the oceans, and the technology and logistical support needed to install and maintain a geomagnetic observatory on the seafloor is substantially more complex and more costly than that required on land. Remote islands also present logistical difficulties, as is reflected in the limited number of stations in the Indian and Southern Oceans, and in addition are often geomagnetically anomalous. These last factors have led to a concentration of stations on continents.

A few quantitative analyses of the improvement which would be obtained by a more even global distribution of geomagnetic observatories have been performed [*Barker and Barraclough*, 1985; *Peddie*, 1992; *Langel et al.*, 1994]. These studies addressed the effect of filling obvious gaps in global coverage. As summarized below, all of them reach the conclusion that new stations are needed to cover the Indian, Equatorial and South Pacific, and North and South Atlantic Oceans. If these holes are plugged, the error in the IGRF vertical component and total field inten-

sity will be reduced by up to 1000 nT at high southern latitudes where the errors are presently largest. A more even distribution of stations will also enable studies of the deep electrical conductivity of Earth to be performed with a resolution comparable to that of seismic tomography.

Barker and Barraclough [1985] studied the effect of station distribution on secular variation models, and showed that large (up to 1000 nT over 10 years) errors can accrue in the South Pacific where station coverage is particularly sparse. *Peddie* [1992] examined how the location of geomagnetic observatories affected the computed secular change in declination, and concluded that about 15 observatories were needed in the North and South Atlantic, and Equatorial and South Pacific Oceans to keep the rms error to less than one degree over several decades of time. *Langel et al.* [1994] used a covariance analysis of spherical harmonic models determined from the current station distribution to show that accuracy is seriously degraded in regions where data are limited. They further considered the improvement which would be obtained by a more even global distribution. For a 20° or roughly 2000 km spacing, the error in a degree 13 model would be less than 100 nT in all three vector components of the field. This would require 92 stations on an ideal, evenly spaced grid. If icosahedral polygons are drawn around each of the ideal station locations to produce 92 equal area bins and then shifted around on Earth's surface, it can be shown that 60 of the bins contain working observatories and 32 bins are without current data coverage (Figure 2). In particular, there are substantial gaps in the middle of most of the major ocean basins.

These studies and other scientific and social arguments for better geomagnetic field models which will not be repeated here led *Geomagnetic Observatory Task Group* [1994] to propose the addition of 40 new geomagnetic observatories (see their Appendix 5), as shown in Figure 3. Of these stations, 32 can be located on land (usually remote islands) and 8 would have to be placed on the seafloor. Table 1 lists the proposed seafloor station locations. Three of them are located in the Southern Ocean, three are in the Western Pacific Ocean, and two are in the Atlantic Ocean (see Figure 3).

Table 1: Location of Proposed Seafloor Geomagnetic Observatories

Station	Latitude	Longitude
NA1	30°N	48°W
WP1	30°N	144°W
NA2	10°N	36°W
WP2	10°N	132°W
WP3	10°S	120°W
SO1	50°S	108°E
SO2	50°S	144°W
SO3	50°S	108°W

The remainder of this report addresses the technical issues associated with constructing, deploying, and servicing a permanent seafloor geomagnetic observatory. The next section briefly describes the components of a terrestrial observatory along with the procedures employed to

assure reliable absolute control. It also introduces the technical standards used in the INTERMAGNET program which have been adopted to define the requirements for a seafloor observatory. Section D outlines the differences between the terrestrial and oceanic environments which influence the technical design of a seafloor observatory. Section E describes the components of a seafloor geomagnetic observatory, including sensors, control systems, packaging, power, and data recording or transmission. A major technical issue is identified in this section: measuring the absolute direction of the field at the seafloor. Section F addresses logistical issues associated with installation and servicing of a seafloor observatory, and discusses the advantages which would accrue from collocation with other geophysical instrumentation. Section G contains a conceptual design for a seafloor geomagnetic observatory and points the way to necessary engineering development work.

C. Terrestrial Geomagnetic Observatories

A geomagnetic observatory is defined as a facility which records the three vector components and the total intensity of Earth's magnetic field according to internationally-accepted standards for field strength and direction, for timing accuracy, for frequency of recording, and for absolute baseline control. Further, a geomagnetic observatory is intended to be permanent, providing data continuously for decades. A major distinction must be drawn between a variometer installation, in which the temporal fluctuations of the geomagnetic field are measured without absolute control, and a true geomagnetic observatory, which includes regular measurement of the absolute intensity and direction of the field. It is the latter which is of interest in this report.

Existing geomagnetic observatories vary greatly in their capability. Most record the time variations of the field continuously and perform the absolute measurements less frequently at intervals of days to months. There are presently 13 observatories in the United States or its territories, all operated by the United States Geological Survey. These are all part of a project called the International Real Time Observatory Network (INTERMAGNET) which sets technical standards for the measurements and provides near real-time data transmission via satellite to several Geomagnetic Information Nodes (GIN) distributed around the world. The GINs serve as data collection and distribution centers, and are typically accessible over the Internet. As of the end of 1994, there were about 60 observatories in the INTERMAGNET network, largely concentrated in North America and Europe, and five GINs are running in Colorado, Edinburgh, Paris, Ottawa, and Kyoto. INTERMAGNET has established technical standards for geomagnetic field measurement based largely on modern digital technology, as defined in *INTERMAGNET* [1994]. Because these standards are the result of international agreement and meet the needs of the community of scientists using geomagnetic data, they have been adopted as the technical basis for a seafloor geomagnetic observatory. The relevant standards are reproduced in Table 2.

Most modern geomagnetic observatories such as those in INTERMAGNET use fluxgate magnetometer technology to measure the fluctuations of the geomagnetic field. This yields digital data which can be recorded electronically or transmitted to a GIN. The absolute intensity of the field can be measured using a variety of total field magnetometer types, as described in the next section, and can also be recorded or transmitted in digital form. However, determination of the absolute direction of the field typically is performed manually using a declination-inclination magnetometer (also called a DI flux) which combines surveying and magnetometer technologies. Absolute direction measurements are made often enough to ensure baseline accuracies of 5 nT or better at INTERMAGNET stations, typically at weekly intervals. Thus, the instrument suite for a

terrestrial geomagnetic observatory consists of a triaxial fluxgate magnetometer to get the vector variations of the field, a scalar or total-field magnetometer to get the absolute intensity, and a DI flux. Further details on observatory procedures may be found in *Stuart* [1984] and *Coles* [1988]. A comprehensive manual [Jankowski and Sucksdorff, in preparation] on this topic is currently being written under IAGA auspices.

Table 2: INTERMAGNET Observatory Standards

Vector Magnetometer	
Resolution	0.1 nT
Dynamic range	2000 nT (mid-latitude); 6000 nT (other)
Bandpass	DC to 0.1 Hz
Sample interval	5 s (decimated to 1 min for transmission)
Thermal stability	0.25 nT/°C
Long term stability	5 nT/year
Accuracy	±5 nT for archival data
Scalar Magnetometer	
Resolution	0.1 nT
Accuracy	1 nT
Sample interval	30 s (decimated to 1 min for transmission)
Clock accuracy	5 s/month

It is immediately obvious that both vector and scalar magnetometers may easily be adapted to the seafloor environment, and in fact this has long been done for geophysical studies such as magnetotelluric surveys [e.g., *Filloux*, 1987]. However, the absolute direction is another matter entirely, as is illustrated by describing the DI flux and its use. The DI flux instrument consists of a single fluxgate element mounted on the telescope tube of a non-magnetic theodolite with parallel optical and magnetic axes. When making absolute measurements, the fluxgate sensor and telescope tube are first rotated in the horizontal plane until a null (i.e., zero magnetic field along axis) is reached. The telescope is now perpendicular to Earth's field in the horizontal plane. By measuring the angular difference between this position and a previously surveyed and distant marker, it is possible to estimate the declination of the geomagnetic field at a particular time. The telescope is then rotated in the vertical magnetic meridian plane until a null is reached. It is again perpendicular to the field vector at a particular instant. By measuring the angular difference between this position and the local vertical (as given by a level), it is possible to estimate the inclination of the geomagnetic field. If the absolute intensity of the field is measured at the same time using a scalar magnetometer, there is sufficient information to give the three vector components, or equivalently, the declination, horizontal intensity, and vertical force. In practice, the absolute measurement sequence is more involved than this in that nulls are obtained in a total of eight positions to aver-

age out differences between the magnetic and optical axes in the DI flux. These absolute measurements can be compared to the three component instrument used to get the field variations and establish the offsets and baselines. INTERMAGNET recommends that this absolute calibration of the observatory variometer be made at least weekly because the magnetometer baselines can and do change due to temperature fluctuations and instrument drift. More frequent calibration should be performed because the absolute measurements are subject to human operator error and may occasionally be biased by rapid time variations of the geomagnetic field. It is conservatively estimated that this procedure will give the declination and inclination with an accuracy of about 10 seconds of arc.

The above description makes it obvious that terrestrial observatory technology for absolute direction measurement cannot be used at the seafloor, both because it is not automated and because it depends on optical surveying. This was quickly identified as one of the major technical hurdles to be overcome if a seafloor geomagnetic observatory is to be constructed, and is discussed in detail in section 5.

D. The Seafloor Environment

It should be emphasized that the seafloor environment is very different from that on land, and this places strong constraints on the design of a seafloor observatory. It is obvious that an observatory must operate under high ambient pressure; since 10 m of water corresponds approximately to one atmosphere, a typical deep ocean installation must sustain 500 atmospheres of pressure continuously for many years. Seawater is a corrosive medium, and hence serious thought needs to be given to corrosion prevention or protection. In addition, the seafloor environment is not static, and water currents can move seafloor instrument packages, generating noise in the magnetic field that is analogous to wind-induced noise on land. This might be obviated by burying a seafloor package or emplacing it in a borehole, but the high cost and logistical difficulty of such approaches suggest that careful package design to minimize vortex shedding and direct movement is better. This typically means minimizing the size and height above the seafloor of all observatory components and/or mechanically decoupling them from their installation bed. However, the seafloor environment offers unprecedented (by comparison to land) thermal stability; temperature fluctuations at the deep seafloor are rarely in excess of a few tens of millidegrees away from mid-ocean ridge crests, with the dominant variability being at tidal periods or longer. Thus, careful design of electronic systems to minimize or remove thermal effects is not required.

The seafloor electromagnetic environment is also markedly different from that on land. The continents are in direct contact with a near insulator, the atmosphere, which allows the nearly instantaneous propagation of electromagnetic signals with essentially no attenuation. In contrast, the seafloor is covered by many kilometers of seawater whose conductivity ranges from as much as 5 S/m near the surface to about 3.2 S/m below the main thermocline at depths of a few hundred meters. The highly conductive seawater acts as a low pass filter for fluctuating EM fields generated above it in the ionosphere and magnetosphere, and little power is present at the seafloor at frequencies above a fraction of a Hz in water greater than a few hundred meters deep. Contamination by man-made or cultural sources is substantially reduced by the water layer, and need not be considered further. The ocean filtering effect may be quantified as described by *Chave et al.* [1991], and is summarized by Figure 4. Note that the attenuation of the horizontal magnetic field is quite sensitive to the conductivity of the underlying earth, but at full ocean depth (5000 m), there is little signal left at periods shorter than 100 s or so, and significant attenuation is present at

periods as long as a day. The vertical magnetic field varies like the electric field shown in Figure 4, and is attenuated only at short periods. However, in the absence of other sources which will produce geophysically-interesting variability at short periods, there is little reason for a seafloor observatory to sample the fields as rapidly as required by the INTERMAGNET standard in Table 2. Even one minute samples would be excessive, and five minute values might be a better target. This has obvious and positive implications for data storage and transmission requirements.

The ocean is in continual motion on all spatial and temporal scales, generating electromagnetic fields by dynamo interaction with Earth's magnetic field in a manner identical to the principle of an electric generator. Motionally-induced magnetic fields are typically much weaker than their electric field counterparts based on both theory and observation [*Chave and Luther, 1990*]. It is unlikely that motionally-induced magnetic fields are a significant issue at periods shorter than a day; the dominant oceanic variability in the deep ocean is due to internal waves for which the seafloor magnetic field signature is quite weak [*Chave, 1984*]. However, motional induction by the oceanic tides is large, and in fact constitutes at least as important a source at lunar and some solar tidal periods as does the external component. At longer periods, motionally-induced magnetic fields are more problematic. *Lilley et al. [1993]* reported the observation of 30 nT amplitude fluctuations with a time scale of order 50 days induced by the eddy field of the East Australian Current, a typical intense western boundary current. While this magnetic signature may be especially intense due to the presence of a thick layer of conductive sediments, its existence and theoretical considerations suggest that motional magnetic fields may be important where the depth-averaged (barotropic) part of the water velocity field is large and the sediment layer is thick. In such regimes, it is likely that strong motional magnetic fields with arbitrarily long time scales will be present. This would certainly include most western boundary currents like the Gulf Stream, and in fact it would be prudent to exclude the boundary current recirculation to the east where the eddy kinetic energy is large. The eight sites listed in Table 1 are all located away from western boundary currents, and little difficulty is anticipated at the Atlantic and Western Pacific sites. The three Southern Ocean sites may be more problematic; the Antarctic Circumpolar Current is an intense and barotropic flow with a larger transport than the Gulf Stream, and might be a source of significant motional magnetic fields.

There is another important difference between the seafloor and terrestrial magnetic field environments that may influence the technical approaches to, and requirements for, absolute direction measurement. On land, the magnetization of the near surface rocks is weak except in volcanic terrain, and hence local remanent magnetization does not strongly influence the static or DC magnetic field that is measured except in unusual cases. Further, in most instances, any magnetized rocks in the continental crust are located sufficiently far away that their magnetic signature is substantially attenuated due to potential field upward continuation. By contrast, the magnetization of the basaltic ocean crust is stronger by 1-2 orders of magnitude as compared to continental rocks, with typical natural remanent magnetizations in excess of 1 A/m [*Johnson and Pariso, 1993*]. Further, the sedimentary layer on the deep ocean floor is rarely more than a few hundred m thick and hence the magnetic fields due to crustal remanence are not as attenuated at the observation point as they would be on land. The basalt flows and underlying gabbros contain a remanence in the direction of the geomagnetic field when they were emplaced at a mid-ocean ridge, and can display local static field anomalies as large as 1000 nT within 100 m of the seafloor [e.g., *Tivey and Johnson, 1993; Tivey, 1994*] with horizontal scales proportional to the spreading velocity and reversal time scale, but typically a km or less. This corresponds to a mid-latitude directional shift for a seafloor observer (when superimposed on the static geomagnetic field due to internal pro-

cesses) as large as 1° . While a more typical seafloor magnetization might yield a directional error of a fraction of a degree, it is unlikely to be as small as 1 part in 10^4 (5 nT in 50,000 nT) as is suggested by the INTERMAGNET standard. This means that the baseline for a seafloor geomagnetic observatory will always contain an unknown constant offset caused by short spatial scale, near bottom remanence, and this offset will probably exceed that for any terrestrial observatory. The only possible way to remove this offset would be careful and detailed near bottom mapping of the geomagnetic field with adequate resolution to delineate the intense short wavelength features which bias the observed DC field. This would require a survey at about 1 m height above the seafloor covering a disk centered on the observatory site whose radius is a few times the sediment thickness (i.e., the distance from the seafloor to the magnetic sources) with precise (tens of cm) navigational accuracy. This cannot be accomplished using a deep-towed vehicle from a surface ship. Either submersible or autonomous underwater vehicle (AUV) technologies could do the task.

All of these points suggest that serious attention to site surveying will be required early in the planning stages for a seafloor geomagnetic observatory. Site surveys should include acquisition of narrowbeam bathymetry in the vicinity of the observatory, and may require near-bottom geophysical surveying as well. The need for the latter will have to be decided on a site-by-site basis depending on the thickness of the sedimentary layer and the regional magnetic anomaly pattern. Information on these quantities is available for most of the observatory sites listed in Table 1, with the possible exception of the three Southern Ocean locations. Estimates of the size of motionally-induced magnetic fields can be made from simple models of the ocean flow and electromagnetic theory given in *Chave and Luther* [1990]. However, their influence cannot be removed from data, but rather must be minimized by locating observatories away from the largest sources. Note that terrestrial observatories located near coastlines and in the vicinity of strong boundary currents are probably contaminated by motional magnetic fields, although this was not a consideration in their siting and is not factored into data analysis procedures.

E. The Components of a Seafloor Observatory

In this section, the technical requirements for a seafloor geomagnetic observatory will be examined and some possible approaches to implementation will be given. It should be emphasized in advance that a major development effort will be required to construct a state-of-the-art seafloor geomagnetic observatory, and that the task is much more complex than simply placing a few commercially-produced subsystems inside pressure cases and powering them with batteries. This is especially true for absolute direction measurement, where it has already been demonstrated that the terrestrial approach is not immediately transferrable to the seafloor environment.

The components of a seafloor observatory divide into five areas: sensors, data recording/transmission, observatory timing and control, power, and packaging. These will be examined in turn, but it should be noted in advance that choices in one area may strongly influence requirements in another; for example, sensors with large energy requirements constrain the power budget. These trade-offs will be enumerated in the discussion. It should also be emphasized that power is a serious concern for a seafloor observatory. An average power consumption of the entire observatory approaching a watt would be huge by oceanographic standards presuming that batteries are the energy source, as is highly likely. Finally, a seafloor observatory should be philosophically treated as akin to a spacecraft. This means that redundancy of major sensors should be planned whenever possible, and a fail-safe design approach should be used so that the catastrophic demise of one

subsystem does not affect another. This will require an overall observatory controller with some intelligence, and would be helped tremendously by data telemetry so that the observatory status can be monitored in near real time.

1. Sensor Components

The major sensors required for a seafloor geomagnetic observatory include a three component vector magnetometer, a scalar or absolute intensity magnetometer, absolute direction sensors, and tilt detectors. The first two and last do not require major innovation, while seafloor measurement of absolute direction does present major new challenges.

a. Vector Magnetometer Sensors

Three principal technologies exist for measurement of the vector magnetic field: Delta I-Delta D (DIDD) systems, fluxgate sensors, and suspended magnet variometers. Emerging technologies like magnetostrictive and magnetoresistive sensors may reach sufficient maturity in the future to be added to this list. In addition to the above, an independent means of determining the relative field direction, such as an automated DI flux as described in subsection 1c, will be required.

The DIDD system consists of two mutually perpendicular deflection coils arranged around a scalar magnetometer (usually a proton magnetometer). The deflection coils are oriented so that their fields are perpendicular to the geomagnetic field vector in the vertical magnetic meridian plane (inclination coil) and in the horizontal plane (declination coil). In operation, the proton magnetometer is read when equal and opposite currents are sequentially introduced into the inclination and declination coils; an undeflected reading is also taken. These five readings are sufficient for calculation of the instantaneous orientation of the field vector with reference to the axis of the coil system. The result is given in small difference angles in the inclination and declination planes (hence, the name: Delta I-Delta D). Since the inclination and declination angles of the coil system are known from independent absolute measurements, algebraic addition of the small difference angles gives the total inclination and declination angles of the geomagnetic field. With the undeflected total field reading, these angles may be used to determine all three components of the magnetic field.

However, the DIDD system has a number of disadvantages when used in an ocean bottom observatory:

1. The system must be accurately aligned to within about a degree of the geomagnetic field vector, requiring servo control of the coil system.
2. The deflection coil currents and the proton magnetometer polarizing fields will disturb other nearby instruments.

It would be suitable only if it could cover all the magnetic measurement tasks of an ocean bottom observatory. Unfortunately, it cannot, because like any other vector variation instrument, its accuracy is effected by pier tilt. Thus, the DIDD system requires calibration by another independent absolute instrument. For all of the above reasons, the DIDD system will not be further considered.

Commercially-produced ringcore fluxgates are available which have noise levels of about $0.02 \text{ nT}/\sqrt{\text{Hz}}$ at 0.1 Hz; baseline stabilities of about 3 nT/year are believed possible [Russell *et al.*, 1983; Narod and Russell, 1984]. Sensitive and stable bar fluxgates have also been developed. The electronic circuitry associated with such high performance fluxgates is complex since magnetic variations have to be referred to the stationary geomagnetic field and not to the natural fluxgate null. The stability requirements involve both the intrinsic null of the magnetic core and that of the

feedback and digitizing electronics, both of which have to operate against the total geomagnetic field. This means that the minimum stability of the feedback and digitizing electronics is of order 1 part in 10^6 if the magnetic field sensitivities and stabilities in Table 2 are to be met. This is certainly feasible, but carries some penalty in power consumption and complexity. A few tens of ring core fluxgates have been operated at geomagnetic observatories around the world for several years. They meet INTERMAGNET standards for resolution and long term stability of baselines. As in the case of all vector variometers, their baselines must be calibrated with independent absolute instruments.

The chief disadvantage to fluxgate sensors for a seafloor observatory application is the high power requirement (typically, at least 0.25 watts per component). This can be obviated somewhat by turning the sensor on only when a reading is desired at a significant sacrifice in long term stability and baseline control. Power consumption approaching or exceeding a watt is huge by oceanographic standards when batteries must serve as the source, as will probably be the case for most seafloor observatories. However, one advantage of fluxgates is that they can stably detect zero field conditions, and hence careful feedback coil design enables them to be used as absolute vector magnetometers. While such fluxgate instruments do not typically meet the accuracy requirements for an observatory, they are capable of operating without careful *a priori* spatial alignment. This is a real advantage for a seafloor observatory.

A second magnetometer technology in current use by US academic investigators is based on custom-made, suspended magnet variometers using optical null detection and electronic feedback [Filloux, 1987]. The principle of operation is illustrated in Figure 5. A light beam is focussed by a condensing lens system onto a mirror attached to a magnet suspended from a stiff tungsten fiber and encased in viscous silicone oil. The light beam passes through a narrow slit placed in front of the condensing lenses and then through an objective lens placed near the mirror. The reflected light beam passes through the objective to form an image of the slit on a dual photodiode array. The differential output of the photodiode array supplies current to a feedback coil which generates a magnetic field normal to the magnet. The resulting torque twists the suspension until the slit image is centered on the photodiode array. Thus, the current in the coil is proportional to the magnetic field normal to the magnet. These sensors typically require power at the 10 milliwatt level per channel, are capable of sensitivity which substantially exceeds that of a ringcore fluxgate, and appear to have very high long term stability, although quantitative measurements of this are presently lacking. In particular, the requirements on the associated electronics are not stringent, in contrast to the fluxgate sensor. Their stability is limited only by creep in the tungsten fiber, which can be minimized by careful heat treating, and fluctuations in the output of the light emitting diode source, which can be reduced substantially by custom fabrication and selection. As soon as a prototype is available, stability measurements of this sensor will be made at a US observatory. The suspended magnet sensor is normally configured to measure the magnetic field fluctuations relative to an arbitrary reference rather than the actual vector field. This is achieved by initial rotation of the entire sensor to null using a servomotor, and the result operates as a magnetic variometer. However, if the sensors could be oriented in an absolute sense with sufficient accuracy, the feedback current would be proportional to the true vector field. Their chief disadvantage is that they must be individually constructed in academia and are not commercially available. It is not likely that this situation will soon change given the limited market for geophysical magnetometers.

The costs of either ringcore fluxgates or suspended magnet variometers are comparable. Either technology would require about US\$10K per three components. Assuming that either

approach can meet magnetic observatory standards with respect to both sensitivity and long term stability, the major remaining criteria on which to base a selection are power consumption and availability. In the first instance, the suspended magnet variometer offers significant advantages, while the ringcore fluxgate is clearly more readily acquired in the commercial marketplace. This suggests that suspended magnet variometers will prove to be the sensor of choice in remote applications where intervals between servicing will be long and hence conservation of battery power is paramount. In less remote areas or where alternate power sources such as submarine cables are available, the ringcore fluxgate may be better.

b. Absolute Intensity Sensors

As is the case on land, absolute measurements on the ocean bottom will require a scalar magnetometer to measure the total field. This instrument should have an absolute accuracy of 1.0 nT or better and a resolution of 0.1 nT (see Table 2). It should have high reliability and a lifetime of at least 5 years. It should also have a low average power requirement (~100 milliwatts or less) when operated at 2.5 minute intervals. On land, several 30 s samples are used in a 120 s period low pass numerical filter operator to produce 1 minute samples for storage or transmission; for the seafloor, 5 minute archived samples are more reasonable as discussed in the previous section. An additional requirement for the ocean bottom case is that the scalar magnetometer produce very little in the way of external magnetic field disturbances. This is necessary because, in all likelihood, the relatively small size of the ocean bottom observatory platform will result in the scalar magnetometer being very close (1 or 2 m at most) to other magnetic field sensors. For this reason, the proton precession magnetometer with its frequent and intense DC polarization field can be ruled out at the very beginning, despite its use at the majority of land observatories.

The scalar magnetometer technologies to be considered include:

- Overhauser proton magnetometer
- Optically-pumped potassium magnetometer
- Optically-pumped rubidium magnetometer
- Optically-pumped cesium magnetometer
- Optically-pumped He⁴ magnetometer
- Nuclear precession He³ magnetometer

The optically-pumped potassium, rubidium, and cesium magnetometers are unsuited for this application because of the relatively high power requirement for electric heaters to maintain the alkali metals in a gaseous state. He⁴ has a broad resonance line which does not lend itself well to good absolute accuracy. Furthermore, because of the requirement for continuous excitation of the lamp and absorption cell, it is doubtful that the average power could be reduced to 100 milliwatts. By contrast, the nuclear precession magnetometer using He³ has a very long polarization lifetime (hours to days). Although its polarization cycle would probably disturb the other sensors, the interference might only be for a few seconds once per day. It would be possible to edit or remove the disturbance from the data after the fact. This system should be able to meet the accuracy and power requirements. However, the technology is just past the experimental stage, so reliability and lifetime have not been established, and the cost is very high, approaching US\$100K per sensor due to the limited market.

In the Overhauser proton magnetometer, a solution containing free radicals (as well as protons) permits polarization to be achieved by radio frequency (60.7 MHz) pumping. The radio frequency polarization can be periodic or continuous. The important point for an ocean bottom observatory

is that the radio frequency polarization is at a sufficiently high frequency that it can be filtered out and will not disturb other nearby sensors. In fact, conducting seawater serves as a natural shield; the e-folding scale for 60 MHz electromagnetic waves is 4 cm and hence at a separation of 1 m the field will be attenuated to virtually nothing. The absolute accuracy of the Overhauser magnetometer is below 1 nT. Average power consumption is also quite low. For example, the off-the-shelf Overhauser magnetometer sold by GEM Systems (Richmond Hill, Ontario, Canada) is polarized for 1.6 seconds at a consumed power of 1 watt. For measurements every 2.5 minutes, this gives an average power of 11 milliwatts. Actual operating experience with GEM Overhauser magnetometers have shown lifetimes of the special fluid in which they are immersed (and the electronics) to be at least 8 years. From all of the above, it would seem that an Overhauser proton magnetometer is the wisest choice for the scalar magnetometer component of the ocean bottom geomagnetic observatory. The cost of an Overhauser instrument is about US\$8K.

c. Absolute Direction Measurement

As has been noted earlier, measurement of the instantaneous absolute direction of the field vector is clearly the major technical hurdle to constructing a seafloor geomagnetic observatory. Two very different approaches were identified at the workshop, and are described below. The first of these uses a combination of a north-seeking gyroscope and local vertical reference with a single fluxgate sensor to automate the terrestrial DI flux. While considerable further development effort is required, preliminary work at the Institut Royal Meteorologique in Belgium is very promising. The second approach is based on precision acoustic navigation of a concrete slab containing the observatory using technology that has been developed at Scripps Institution of Oceanography for seafloor geodetic measurements on mid-ocean ridges. This would require only the construction of precision acoustic transponders working at higher frequencies than present.

However, it should be noted in advance that the intense magnetization of the oceanic crust places a strong constraint on the accuracy with which the absolute field direction needs to be measured. This is because the near-bottom magnetic field from natural remanence produces a vector offset in the local magnetic field which can only be measured by careful magnetic surveys around the observatory site. Such surveys will clearly be done only once at or prior to the installation of an observatory. The accuracy with which the local magnetic survey can be done will determine the accuracy with which the observatory measures the absolute geomagnetic field excluding the strong local sources. In the absence of a local survey, or at least within the errors inherent to such a survey, there will remain an unknown vector offset to the geomagnetic field measured by the seafloor observatory. This suggests that the purpose of absolute direction measurement is to ensure that this offset remains fixed rather than varying with time due to instrument drift or monument motion. Thus, absolute direction measurements relative to a fixed local marker are nearly as useful as those referenced to a global frame; the angular difference between the local marker and true north will simply add to the unknown offset from local magnetic sources.

It is useful to estimate the overall absolute accuracy with which an observatory at each of the sites listed in Table 1 would have to determine the declination and inclination of the geomagnetic field to meet the 5 nT criteria used for INTERMAGNET stations. Note that this calculation does not take into account local magnetic sources, and hence may be regarded as an upper limit with which the field direction needs to be measured relative to a local marker; additional uncertainty will accrue from errors in the local magnetic survey. Expressions for the angular errors in declination and inclination are

$$\Delta D = \text{asin}\left(\frac{5}{H}\right) \quad (1)$$

$$\Delta I = \text{asin}\left(\frac{5}{F}\right) \quad (2)$$

where H and F are the horizontal and total magnetic field in nT. Table 3 contains (1) and (2) computed for each of the ocean bottom observatory sites listed in Table 1, where H and F were obtained from the IGRF 1990 model.

Table 3: Maximum Angular Uncertainty for 5 nT Absolute Field Determination

Site	Latitude	Longitude	H (nT)	F (nT)	ΔD (")	ΔI (")
NA1	30°N	48°W	27000	43000	38	24
WP1	30°N	144°W	26000	41000	40	25
NA2	10°N	36°W	30000	31000	34	33
WP2	10°N	132°W	31000	34000	33	30
WP3	10°S	120°W	30000	31000	34	33
SO1	50°S	108°E	11000	64000	94	16
SO2	50°S	144°W	22000	53000	47	19
SO3	50°S	108°W	24000	44000	43	23

Thus, declination and inclination must be measured with an accuracy of about 30 and 15 seconds of arc, respectively, to meet the 5 nT overall accuracy criterion. In some instances, these values may be relaxed, depending on the local magnitude of the geomagnetic field.

As described in Section C, absolute measurements of the declination and inclination are performed manually at terrestrial observatories using a DI flux sensor, which combines a null flux-gate magnetometer sensor with a theodolite. If this procedure could be automated, removing the need for a human operator, then a first major step toward seafloor absolute direction measurements would obtain. The development of an automatic DI flux is in progress at the Institut Royal Meteorologique in Belgium, with collaboration from the University of Liege and the University of Cambridge. This requires robotization of both the vertical and horizontal axes as well as overall leveling of the instrument using non-magnetic motors and angular encoders. Azimuth mark sighting may be replaced by an azimuth transfer using an autocollimator from a gyrocompass provided that the telescope of the DI flux is replaced with a mirror and the gyrocompass bears a mirror normal to its spin axis. This would allow location of the gyrocompass away from the automatic DI flux unit. Alternatively, the two can be combined in one instrument as described below.

The purpose of a gyrocompass is to sense the Earth's rotation and hence find the plane through the observer and the rotation axis of Earth. A horizontal in this plane gives the north-south direc-

tion. Commercially available geodetic gyrocompasses are based on a top spinning around a horizontal axis. The spinning top gyro is suspended in Earth's gravity field with the centre of gravity of the pendulum located below the spin axis. The rapidly spinning top tends to keep its axis fixed in direction. The rotation of Earth will cause the pendulum to depart from the vertical after a time, producing a torque about the top's centre on the pendulum mass, and causing it to precess around the vertical axis. One can show that this precession will bring the spin axis toward the north-south position, with equal rotation directions for Earth and top. Of course, the spin axis will overshoot the north-south direction and the same process will take place again with reversed torque, bringing the spin axis back, and so forth. This gives a sinusoidal motion, typically of several minutes period and with very low damping. The main difficulty in observing with the classical gyrocompass is caused by this low damping, forcing the observer to make measurements on a sine-wave in lieu of sighting at a well defined spot. Note that changing the top rotation direction will give the true south direction and this property can be used to compensate for some errors in the measurement. Given the need for a 30" accuracy in declination (see Table 3) and the inherent 10" accuracy of the DI flux yields a requirement for 20" accuracy in determining true north from the gyro. This is easily met if sufficient time is allowed to average out the precession, or else active damping is employed.

Alternative gyrocompass technologies include the ring laser gyro, fiber optic gyro, and nuclear gyro. The former is very fast (unlike the conventional gyro) and extremely accurate, but is quite expensive, very power hungry, and not commercially available. The fiber optic gyro is also fast, carries a medium price tag, but is probably not accurate enough in its present state of development. The nuclear gyro is fast and of medium accuracy, but is also power hungry and not commercially available. All three of these gyros would require magnetic shielding to avoid interference with other observatory instruments. Thus, at the present time, conventional gyrocompass technology appears to offer real advantages. For applications where magnetic contamination is not a problem, commercial spinning top gyrocompasses could be adapted, although active damping would have to be added. For other applications, a non-magnetic version would have to be developed.

A conceptual ocean bottom magnetic observatory incorporating the automatic DI flux sensor is shown in Figure 6. Both the DI flux and gyrocompass are symbolically gimballed by being mounted on spherical caps centered on the sensor. An optical autocollimator is used to transfer angular information from the gyro to the DI flux. Since an autocollimator is able to work at a distance, the gyro and its associated components need not be made non-magnetic, depending on their location. They are located away from the magnetically-clean end of the mounting base containing the DI flux, vector magnetometer, and total field sensor, together with the remaining non-critical parts of the observatory (e.g., batteries, data logger). A separation of at least 1 m would be required. An absolute measurement protocol might occur as follows (see Figure 6):

1. The DI flux and gyro are coarsely and finely levelled using the triaxial fluxgate sensor and a tilt reference as a guide.
2. The DI flux locates magnetic north and the vertical, hence giving the magnetic north azimuth and inclination of the field.
3. The gyro is spun up and oriented toward true north using the magnetic north direction as a first guess, the clamp is released, and active damping is switched in.
4. True north is located by following the rotor with the autocollimator and the gyro azimuth servomotor, and the azimuth is read out.
5. The DI flux mirror is oriented so the autocollimator light beam is normally incident, giving

the absolute azimuth of the DI flux azimuth encoder and hence the declination.

6. The measurement sequence is repeated with everything reversed to remove encoder errors. The difficulty with this sensor arrangement is that separate pressure housings with optical windows would have to be constructed. There is no particular problem with including optical windows in the ends of cylindrical pressure cases, but this will probably require large diameters depending on how small the gyroscope and DI flux can be made. Thus, packaging of separate DI flux and gyrocompass instruments may prove difficult.

A second conceptual prototype ocean bottom magnetic field sensor based on the automatic absolute DI flux instrument appears in Figure 7. In this instance, the gyro and DI flux are co-located, eliminating the problems outlined above, but requiring that the gyro be non-magnetic. In particular, non-magnetic electrostatic motors would be required to operate the gyro. The entire assembly containing the DI fluxgate sensor and gyrocompass is gimballed, with non-magnetic motors providing azimuth and site motion and non-magnetic encoders reading out the angles. A non-magnetic gyro is located above the biaxial fluxgate and yields the orientation of the gimbal assembly with respect to true north. A tilt sensor provides a local vertical reference. The measurement protocol would require reversal of the azimuth and site axes to remove fiducial errors in the encoders. The base is attached to the monument on which the seafloor observatory is placed, and could include a scalar magnetometer to provide a complete suite of instruments. Note that the biaxial fluxgate sensor could be operated in a DI variometer mode between taking absolute direction measurements, and hence supplant a separate three component vector magnetometer.

The fabrication of an instrument like that shown in Figure 7 will require a significant development effort. It is difficult to estimate the time and costs required, but it probably approaches 4 man-years of engineering effort and US\$500K in components to build the first unit. Serious attention will have to be given to the power budget; the gyro and gimbal systems will require substantial (by seafloor standards) energy. This is especially true if encoder errors are to be removed by reversing the sensor. However, once completed, such an instrument would be extremely attractive due to its compact size and self-contained nature. In fact, it would be very useful for automating terrestrial geomagnetic observatories, and is presently under development for just that purpose.

As an alternative to the absolute DI flux instrument, it is possible to determine absolute direction on the seafloor through acoustic means. Technology currently exists in the form of precision acoustic transponders that provide on the order of centimeter level location capability at full ocean depth using a 13.5-17.5 kHz swept signal [*Spiess et al.*, 1980; *Spiess*, 1985]. These transponders differ from conventional units which simply detect the presence of an interrogation pulse and send a reply ping, resulting in meter level location accuracy at best. Precision transponders record the incoming signal and, on command, return it with a preset time delay. The returning signal is then cross-correlated with the original transmission to measure the total elapsed time, from which the known delay is subtracted. This eliminates variability induced by much simpler detection schemes, and results in travel time measurement precision that approaches 5 microseconds, or at least 100 times better than conventional transponder technology. The major remaining source of error occurs when the sound velocity profile of the water column is used to convert travel times to ranges. This is because the sound velocity profile varies with time. The most important source of this variability is internal wave activity in the upper ocean which has a short spatial scale (up to hundreds of m) and high frequency (less than an inertial day) character, and can be averaged out statistically by ranging on precision transponders over many wave periods and from many locations. Conservatively, one should expect precision transponders to yield location accuracies of order 10 cm when the acoustic path traverses the upper ocean. Note that better

accuracy can be achieved between transponders located near the seafloor where sound velocity variability is small. A network of precision transponders is currently installed on the Cleft Segment of the Juan de Fuca Ridge to measure absolute motion associated with plate accretion, and will be monitored for at least five years on an annual basis.

For a geomagnetic observatory, it is necessary to transfer an absolute direction from the sea surface, where it can be referenced to a standard frame using the Global Positioning System satellites, to the seafloor. This can be accomplished by placing two primary reference ~10 kHz transponders on the seafloor spaced about 4 km apart. These would be located on 5 m high towers to take care of the upward refraction of sound near the seafloor. Each tower would also contain a ~50 kHz precision transponder whose purpose is to transfer the primary reference direction to a second pair of ~50 kHz transponders located on 5 m high towers near the observatory. This additional transponder pair would have a baseline which is orthogonal to that of the primary towers and be spaced about 30 m apart.

The system would work as follows:

1. The latitude and longitude of the primary reference transponders would be determined using GPS-acoustic techniques similar to those employed for geodetic measurements. This yields the distance between them and the absolute azimuth of the line joining them.
2. Either of the two secondary transponders located near the observatory would transmit to the 50 kHz transponders located on the primary towers. The replies received at the two secondary transponders will yield the distance to each of the primary reference units and the angle (nearly broadside to the secondary hydrophone pair) between the axial line of the secondary pair and the paths to each of the primary reference towers.
3. With these lengths (approximately 4 and 2 km, respectively) and the two small angles, one can calculate the angle between the primary reference line (which is known in a geographic coordinate system) and the line through the two local towers.

This geometry leads to a rather simple situation for estimating errors. The angles must be measured with accuracy comparable to that for the required azimuthal accuracy of the seafloor observatory, or about 30 seconds of arc. Hence, the distances must be known to a fractional accuracy comparable to the desired angular accuracy expressed in radians. The geographical locations of the primary reference transponders can easily be measured to 20 cm. Over 4 km, this means we know the orientation of the baseline separating them to 5×10^{-5} , or about 10 seconds of arc. The high frequency transponders located near the observatory can measure the order 2 km ranges to the primary references conservatively with 10 cm uncertainty, which yields the same 10 arc second error component as for the longer path. If the high frequency pair has 1000 wavelength (30 m) spacing and the phase differences in the arrivals at the two are measured to 0.1 wavelength, then this component contributes 20 arc second for each of the two angles, or an rms sum of a little over 30 arc seconds overall. This is a conservative calculation, and yields the 30 m baseline absolute orientation with the required accuracy. In practice, substantially better accuracies can be achieved.

The remaining problem is transfer of this baseline to the observatory. This is easily accomplished through optical means using corner cubes located on the secondary reference towers and servoed laser systems mounted at the four corners of the slab containing the observatory. The servo systems will allow alignment of the lasers and corner cube. Laser technology can determine the ranges from the slab corners to the towers with sub-millimeter accuracy. This translates into an additional angular uncertainty of order 0.1 mm in 15 m, or about 1 arc second. This has a negligible effect on the overall error budget.

The purpose of the acoustic-optical system is two-fold: to transfer an absolute direction from the sea surface (and hence a geographic reference frame) to the seafloor, and to monitor any changes in the azimuthal orientation of the geomagnetic observatory in this coordinate system. The former can be accomplished with the required accuracy using existing technologies. Aside from local tectonic changes which are expected to be minimal for the mid-plate sites listed in Table 1, the major source of temporal change in the observatory azimuth would be differential settling of the base slab into the sediment. This should be small after an initial transient upon installation. Thus, variations in the measured slab azimuth with time should be minimal. The absolute orientation information can be converted to absolute field direction using an automatic DI flux instrument (less gyrocompass) as described earlier, or with a precisely oriented vector fluxgate sensor. Either sensor measures the field direction relative to its orientation on the observatory base, and the acoustic-optical system orients the base relative to an absolute reference frame. In this sense, the acoustic-optical system replaces the gyroscope in Figures 6 and 7.

All of the technologies needed for the acoustic-optical system currently exist. A minimal development effort would be required to scale existing precision transponders up from ~ 10 kHz to ~ 50 kHz. Acquisition costs for precision transponders are about US\$20K apiece. Laser ranging systems could be built for about US\$10K apiece. This yields a bottom line of about US\$160K. The power requirement is not an issue; existing precision transponders have lifetimes of at least five years, and the laser system will not require significant power due to intermittent operation.

As a substantial scientific bonus, acoustic ranging on the primary reference transponders fixes two points on the seafloor in an absolute reference frame, and hence is of considerable interest for geodetic studies. To achieve a geodetically-useful accuracy of 1-2 cm, one or two additional precision transponders would be required. Thus, a seafloor geomagnetic observatory using the acoustic-optical system also serves as a major component of a geodetic observatory.

d. Tilt Sensors

Tilt sensors serve two purposes: to provide a local vertical reference for the magnetic field sensors, and to measure high frequency motion of the sensors caused by either seafloor movement or vortex shedding in near-bottom currents. In the first instance, it is necessary to measure the local vertical direction to better than 15 seconds of arc (see Table 3), or with an accuracy of about 1 part in 10^5 . This is not a stringent requirement; tilt can easily be measured to 1 μ radian or better. However, it is essential that long term drift be minimized, as such temporal variation would immediately translate into drift of the inclination baseline and hence of the field components. This precludes the use of simple, commercially-available capacitive bubble tilt sensors, and probably dictates the use of a custom tilt detector based on the principle of a plumb bob. It is not difficult to fabricate a system which optically tracks the motion of a weight suspended from a strong fiber as shown in Figure 8. The major source of drift for this type of sensor is from fluctuations in the output of the light source due to component aging. This can be measured independently and hence corrected for at some level. The frequency response of this sensor extends from DC to about 0.1 Hz (depending on the viscosity of the oil in which the weight is suspended), and hence it can also serve to detect overall platform motion at high frequencies.

Motion of a seafloor observatory can occur on a variety of time scales due to near-bottom water currents and turbulence. While turbulence is apt to be concentrated at high frequencies, tidally-induced motions and turbulence tied to the tidal cycle may also be present. Bottom turbulence can be minimized by locating observatories away from regions of high eddy energy, such as the western side of ocean basins, but cannot be eliminated entirely. It does not take much sensor

motion to induce significant magnetic field noise; 1 μ radian of rotation corresponds roughly to 10 pT of magnetic field variability at mid-latitudes. While simple averaging or filtering of magnetic field data collected at a high sample rate might be expected to remove much of the tilt noise in vector magnetometer data, it is probably better to independently measure the magnetic and tilt fields and explicitly remove tilt from the magnetic field in real time. This can be accomplished using standard adaptive correlation cancellation filters [Widrow and Stearns, 1985].

e. Electric Field Sensors

Technology to measure electric fields in the ocean, and especially short baseline techniques in which electrode reversal must be employed, are extensively reviewed by Filloux [1987]. It would not be difficult or costly to include an electric field capability in a seafloor geomagnetic observatory. However, the scientific case for this is not compelling for several reasons. First, short baseline electric field data are dominated by motional induction at periods longer than a few days [Chave *et al.*, 1992]. This means that long observatory records of the electric field will not be appreciably more useful for geophysical studies of the solid earth (in the sense that longer periods can be used) than those which can be collected in dedicated experiments. Second, the strong motional induction component will probably mask any long period electric fields associated with the toroidal part of the geodynamo, and hence long duration, short baseline records are not likely to be useful in studies of the core. Finally, while extended short baseline electric field records will contain information about the depth-averaged velocity field of the ocean, single records obtained at mid-basin are of limited use in physical oceanography. For geophysical studies of the deep earth and core, it appears that electric fields measured on long transoceanic cables which average away much of the motional induction component are of greater utility [Chave *et al.*, 1992; Lanzetta *et al.*, 1993]. This is not a seafloor geomagnetic observatory issue.

2. Data Recording and Transmission

Perhaps the simplest approach to archiving seafloor observatory data is *in situ* storage and intermittent retrieval by a ship-of-opportunity. This is attractive because it is relatively easy, but has the disadvantage that data are not available in anything approaching real time, and in fact may be delayed by up to several years. This is not a serious problem for most geophysical studies, but precludes the use of the data for any type of forecasting (e.g., calculation of magnetic indices).

It is useful to estimate the amount of storage which would be required for a seafloor geomagnetic observatory. Presuming that 5 minute samples are to be saved, that each channel requires three bytes or 24 bits, and that 7 channels (time, XYZ magnetic field, total field, and DI directions) are to be recorded continuously, then 2.2 megabytes of storage are required per year. This should probably be doubled to allow for full redundancy of all sensors and 10% added to cover ancillary and engineering data logging (e.g., temperature, battery voltages, etc.). This still amounts to less than 5 megabytes of storage per year. This is not a great deal by geophysical standards, and can easily be handled with a variety of existing and low cost technologies, including nonvolatile flash memory modules the size of a credit card or several types of magnetic media. Given the value and importance of the data, it would be prudent to provide for complete duplication of on-board storage; again, this will not tax the technology or appreciably affect the overall cost of an observatory.

The more difficult issue is data retrieval, whether that be at irregular intervals or in near real-time. A simple means of data retrieval is provision of a series of data storage modules which can

be released acoustically by a surface ship-of-opportunity and recovered. The data can then be read out, edited, and archived on land. It would not be difficult to include 5 independent modules each having 1-2 years of capacity. These could be replaced at periodic major service intervals when the observatory batteries are changed; this will be necessary on a five year time scale in any case. The data modules should store the complete data set to allow for loss of a single module, and the observatory should archive all of the data separately as a fail-safe backup. Data storage modules could be constructed for US\$5K apiece, and hence a five year lifetime system could be built for US\$25K. This does not include the cost of separate data archiving at the observatory, but that is not a major expense.

A variant to this scenario would include automatic release of the data modules at fixed (perhaps yearly) intervals. Once it reaches the surface, the module could then transmit its data over a satellite link, obviating the need for a surface ship. The only transmission avenue available at present is Service Argos, but the feasible data rate is much too low to allow the full data set to be sent. It would be possible to send a reduced data set (e.g., hourly or daily means), and this has the significant advantage that it would serve as a periodic check on observatory status. This might be especially useful for the most remote sites (i.e., SO1, SO2, and SO3) where ship visits will probably be separated by years. The full data set would still be archived in the observatory, and hence be recovered when it receives major service. Satellite data transmission from surface modules may become more attractive if any of several planned global telephone systems (e.g., Iridium as proposed by Motorola) become real.

The simplest alternative to *in situ* storage is acoustic transmission of data at irregular intervals upon command to a passing surface ship. Three simple rules of thumb may be applied in assessing the energy requirements and feasible data rates for acoustic data transmission [J. Catipovic, private communication]:

1. 3-6 bits/s may be sent per Hz of bandwidth,
2. 10,000 bits/s may be transmitted over a one km path, and this number scales down linearly as the path length increases,
3. Efficiencies of 1000 bits/joule per km of path are achievable.

This means that 250 bytes may be transmitted per second over full ocean depth (5 km), and hence one year of data (2.5 Mbyte including engineering data) can be sent in less than 20 minutes. This number should probably be doubled to allow for redundant transmission and error correction, but with an upper limit of 1 hour, could easily be accomplished by a ship-of-opportunity. The energy requirement to send a year's data over full ocean depth is about 10^5 joules, which is comparable to the energy content of a single D-size lithium battery. Neither the transmission time nor the energy requirements are severe. Acoustic modems are commercially available at a cost of US\$10K per bottom unit and US\$25K per surface controller. Each observatory would require a bottom acoustic modem (and two for redundancy), but a single surface controller could be used with all observatories. Thus, the cost of acoustic transmission is comparable to or less than that of releasable data storage modules, and hence is an attractive alternative.

Neither of these approaches provides for real-time data transmission, and would yield observatory data only after a delay of months to years. There are ways to achieve near real-time data transmission at a significant increase in cost and complexity. For example, data can be transmitted acoustically to a surface buoy and then be relayed by satellite link to land. Surface buoys can be constructed for US\$50-100K apiece, but lifetimes in excess of a year are very difficult to achieve except at huge increases in the cost of installation. Given the low data rate, there are a number of satellite systems which are suitable for the relay function (e.g., the GOES satellites already used

by INTERMAGNET), and satellite availability can only be expected to increase over time. Buoy survivability and lifetime becomes more problematical at high latitudes such as the Southern Ocean sites listed in Table 1. Finally, it should be noted that an electromechanical tether between the buoy and the observatory is less attractive than an acoustic link due to low reliability of the former.

Finally, there are active plans to reuse active submarine telephone cables for scientific purposes in both the US and Japan. If a scientific cable spans one of the observatory sites, it might prove feasible to connect geomagnetic instrumentation directly to the cable. This is very attractive because it provides virtually unlimited power, a means for command and control of the observatory instruments, real-time status information, and real-time data transmission. However, the installation costs for instrumentation on the cable are probably on the order of US\$1M. This is unlikely to be supportable solely for a geomagnetic observatory, but co-location with seismic and other instrumentation might make it an attractive alternative as the installation costs are shared. At the present time, the most likely of the candidate observatory sites for cable connection is WP1, as it coincides with a planned cabled geophysical observatory called Hawaii-2 Observatory (H₂O).

3. Observatory Timing and Control

A seafloor geomagnetic observatory will have to operate under the control of a master computer whose functions include monitoring all sensors to ensure functionality and proper adjustment, smart power control (see next section), checking for data integrity, and control of data storage. None of these tasks requires significant computing power, and hence there is a multitude of low cost hardware available for the purpose. A critical issue in selecting the right computational engine will be minimizing the power consumption, assuming that batteries will be the power source. The most difficult design task for the observatory controller will be software rather than hardware oriented; it is critical to develop control software which operates in a fail-safe manner such that the catastrophic demise of part of the observatory does not bring the rest of it down. It would also be wise to develop redundant control computers with the capability of cross-checking each other to detect faults.

A master clock will be required to provide timing information to the observatory and provide a time stamp on stored data. The INTERMAGNET standard calls for an absolute timing accuracy of 5 s/month, or about 2 parts in 10⁶ in a year. This level of accuracy is easily achieved with a high quality quartz crystal oscillator operating at very low power; because of the excellent temperature stability of the seafloor environment, there is no need for an oven. Most quartz crystals are cut to operate optimally at room temperature (20°C), but seafloor applications like this are better served if the minimum in the crystal temperature coefficient occurs at a typical bottom water temperature of 2°C. This requirement is easily accommodated by crystal manufacturers. Finally, it is very difficult to adjust the frequency of a crystal oscillator so that it will be at precisely the right frequency at *in situ* temperature, and a small frequency offset translates into a linear drift of the observatory clock over time. Such a drift is inevitable, but is easily corrected by comparing the observatory apparent time with a standard value upon recovery of the observatory for major servicing. As the major service interval is apt to be long (of order five years or more), and since even a small frequency offset can result in a substantial timing error after a long interval, it will also be necessary to provide the observatory with a means of communicating its apparent time on command. This can be accomplished acoustically, although care will be required so that acoustic

propagation delays can be accounted for. The two-way travel time from the surface to the seafloor at full ocean depth is of order 6.7 s, and if this can be corrected for at the 1% level, the uncertainty in observatory time will be 67 ms which is certainly more than adequate.

The above discussion presumes that the geomagnetic observatory operates autonomously. If real-time two-way communication is available, then timing information or corrections can be provided by a land control site. It would also be possible for a land station to exert considerable remote command and control in place of the observatory master computer.

4. Power

The most likely source of power for a seafloor geomagnetic observatory is batteries. The state-of-the-art in high energy density batteries is based on two types of lithium chemistries. The first of these uses a lithium thionyl chloride chemistry or its variants, and a D-size battery provides 3.6 volts at 14 amp-hour capacity, or about 1.8×10^5 joules of energy. This value should be de-rated by about 10% for operation at seafloor temperature, and must be further reduced for low drain applications. Lithium thionyl chloride batteries do suffer from passivation phenomena which raises the internal resistance and hence reduces their short term (until the passivation layer is destroyed) current delivery capability substantially, and can reduce their overall capacity unless care is used to ensure that they are discharged in an optimal manner. Their cost is about US\$40 for a D-size unit. The second type of battery is based on a lithium manganese dioxide chemistry. These provide 2.8 volts at 10 amp-hour capacity for a D-size battery, or about 1.0×10^5 joules of energy. Their capacity is only slightly reduced in low temperature applications. They do not suffer from passivation and are considerably less expensive at US\$20 per D-cell. The discharge curve for lithium batteries is quite flat, and it is practical to extract nearly all of their energy. They have a shelf life of at least a decade. Lithium batteries are regarded as hazardous material, and special regulations must be followed for shipment and disposal. This may also impact on their use around manned submersibles, depending on the operator.

The number of batteries required for an observatory depends on the power consumption, and this is quite uncertain until the sensor mix is determined. It is useful to compute the number of batteries which would be required to supply one watt of continuous power for a year, and then compare that to the consumption of various sensor mixes. One watt for a day amounts to 86400 joules per day or about 3×10^7 joules per year. This is equivalent to 0.5 lithium thionyl chloride D cell per day or 185 D cells for a year, and would occupy a volume of about $12,000 \text{ cm}^3$ after allowing a 20% margin for the packing inefficiency of cylindrical batteries. The volume could be reduced by about 10% using DD cells instead of D cells. To place these numbers in perspective, the batteries would occupy three 6" id pressure cases 22" long, or a single 9" id pressure case 30" long. The number of batteries should be increased by 30-50% to allow for battery failures and provide a safety margin. The number of batteries required scales linearly with the power consumption and the time interval between battery replacement. Thus, a five year observatory consuming one watt would require a large but still manageable number of batteries. A five year observatory consuming five watts would require a battery pack of truly heroic dimensions, and is not feasible. The cost of a one year supply of lithium thionyl chloride batteries to supply one watt is US\$7.5K without a safety margin, or more conservatively, US\$10-12K.

To place these numbers in perspective, the power consumption of an observatory consisting of a triaxial fluxgate magnetometer, automatic DI flux sensor excluding the north seeking gyroscope,

and scalar magnetometer running continuously is about 1.3 watt plus the power consumed by the master computer, data logger, clock, and servomotors for the DI flux, which presumably run infrequently. Thus, a reasonable minimum average power level for a fluxgate observatory is 1.5 watts without allowing for any sensor redundancy, although presumably spare sensors could be present with the capability to be switched on by the master computer if the main sensors fail. This is manageable with batteries for several years, but is not easy. If the power consumption were doubled to allow fully redundant sensor operation, it quickly becomes impractical. If the triaxial fluxgate sensor is replaced with suspended magnet variometers, then the power consumption drops to about 0.5 watt without sensor redundancy or less than 1 watt with full redundancy. This is a significant power reduction, and bears close attention.

If battery power is used, it is prudent to plan for smart control of multiple banks of batteries rather than using the simpler expedient of paralleling them with diode isolation to prevent back discharge. Smart control would entail active monitoring of the battery banks by the master computer and switching between them in order to maintain a constant and adequate current load on them. This is especially important if lithium thionyl chloride batteries are used because they cannot deliver their rated capacity at low current drains. Active battery management would also allow for early detection and isolation of battery banks containing bad cells.

The only alternatives to lithium batteries are alkaline cells or a variety of rechargeable battery chemistries such as lead-acid types. The former provide about 1.5 volts at 12 amp-hours capacity for a D-size cell, yielding about 36% of the energy of a lithium thionyl chloride battery. While they are inexpensive, their shelf life is much shorter, and serious problems with leaky batteries are frequently encountered in long oceanographic experiments. Thus, they are not recommended for high reliability applications. Rechargeable batteries make sense if a power source is likely to be available to provide energy at regular intervals. However, their self-discharge is typically much larger than for lithium batteries, and it is unlikely that they could power an observatory for multiple years without recharging. They are also much more costly for a given energy density.

More esoteric power sources which might be considered include submarine cables, radioisotopic generators, and fuel cells. Submarine cables can provide hundreds of watts continuously for periods of years, and hence would remove all concerns about power. As in the discussion of data storage, the cost of installing instruments on cables probably precludes their consideration unless other geophysical instruments are to be co-located, and in any case they can only be used where cables exist. They certainly should be considered whenever possible.

Radioisotopic generators are commercially available from Siemens in Germany which can operate to depths of 6000 m and provide more than 20 watts of power continuously for a decade. This unit uses a strontium titanate source to provide heat and a two stage thermocouple to generate electric power, and is International Atomic Energy Agency approved. The cost is about US\$250K. The major difficulties with any radioactive source are legal and political. By international law, radioactive material placed on the seafloor must be recovered and disposed of properly. This disposal can be costly and is fraught with uncertainty due to the volatile politics surrounding anything radioactive in much of the world. Depending on the country deploying a radioactive source, the permitting process can also prove formidable and time consuming. Thus, careful attention to these matters would be required before committing to a radioisotope source for an observatory. Furthermore, the cost is sufficiently high to make batteries an attractive alternative, although for co-location applications where enough instruments are used to consume the 20 watts that is available, the radioisotope generator might prove interesting.

Finally, fuel cells for the deep ocean are still in a development phase. At present, the few units

which are available are designed for high power (order 100 watt) use, mostly with unmanned underwater vehicle applications in mind. Further work would be required to bring the generated power down and the lifetime up so that they would be useful in observatory applications. Thus, fuel cells are an emerging technology which may be interesting at some future date.

5. *Observatory Packaging*

The physical design and packaging for a seafloor geomagnetic observatory will also require careful thought to avoid corrosion problems and allow for ease of installation and maintenance. The major issues which will require development work include the construction of a monument base to hold the observatory which will remain as stable as possible on the seafloor and devising a way to replace the observatory or its individual instruments without appreciably altering their orientation or location.

Corrosion is always a problem with seafloor instruments using metal pressure cases and attachments. The standard material for oceanographic pressure cases is either the 6061 or 7075 alloy of aluminum. Aluminum corrodes readily in seawater, and this is typically avoided by hard coating or anodizing all surfaces exposed to the ocean. While this works well on time scales of 1-2 years, corrosion of aluminum is inevitable on longer deployments, and could ultimately threaten the integrity of a permanent observatory. As an alternative, titanium is a suitable non-corroding material for pressure case and observatory fabrication which has a density and strength comparable to that of aluminum. Titanium is easily machined and welded, and the only minor complication obtains in fabricating cylindrical pressure cases because rolled titanium stock is not manufactured. Instead, pressure cases must be made by trepanning solid bar stock. The cost of titanium is about 30-50% higher than equivalent aluminum stock. It has the additional advantage of being non-magnetic. All metal components of a geomagnetic observatory exposed to seawater should be constructed from titanium for corrosion resistance. Care must be taken to avoid placing dissimilar metals in electrical contact because of their subsequent electrolytic destruction, but this is normal oceanographic practice.

The fabrication of permanent geophysical monuments on the seafloor is in its infancy, but is of broad interest to the geodetic community. In fact, this was a major item of discussion at the International Ocean Network Workshop held in Marseilles, France, in January 1995. The principal issue is one of stability: how to install a base on the seafloor, whether in sediment or on hard rock, which will not move appreciably after some initial transient settling. This can probably be resolved on hard rock by cementing a hard base to the rock substrate, but all of the observatory sites listed in Table 1 are located away from mid-ocean ridge crests where the seafloor will be sedimented. Absolute stability in sediment is problematical and perhaps unachievable. A better approach might be the installation of a heavy base with a large cross section which will initially settle into the sediment but move more slowly with time as the sediment is compacted. At that point, accepting that some movement is inevitable, additional motion can be monitored using tilt sensors to detect rotation about the two horizontal axes and an acoustic-optical system like that described earlier to determine rotation about the local vertical. Alternately, the absolute azimuth of the slab can be determined using an observatory gyrocompass. Either way, the absolute orientation of the observatory base to which all of the sensors are attached will be known and hence the individual data sets can be corrected for local effects. It would be useful to have an *a priori* estimate of the amount of settling which might be expected for different sediment types for the load exerted by the observatory base. This can probably be assessed using geotechnical information

compiled by the Deep Sea and Ocean Drilling Programs. In particular, this would indicate whether the observatory base should be installed at an earlier time than the observatory instrumentation to allow an initial settling transient to die out.

It is possible to put some constraints on the feasible size of an observatory base. Presuming that it will be cast out of concrete whose density is 2500 kg/m^3 (without allowing for reinforcing material), a slab which is 1.5 m on a side and 0.5 m thick would weight about 2800 kg in air and 1700 kg in water. This value would rise if the slab is reinforced with a non-magnetic metal like brass and drop slightly if it is reinforced with fiberglass or kevlar rods. In any case, this is close to the maximum weight which can safely be handled from a research vessel if allowance is made for dynamic loading effects, and hence a substantially larger observatory base would be difficult to construct.

The concrete observatory base is intended to be a permanent installation which would neither be retrieved nor moved after deployment. The geomagnetic observatory will be installed on the base with the intent that it can be removed at periodic intervals for servicing and refurbishment. It is very unlikely that a seafloor observatory can be constructed that will not require overhaul on a five year time scale, and this should be planned for from the beginning. The simplest approach would be to mount all of the observatory sensors on a titanium frame which would in turn mate to a set of pins cast into the concrete base. The purpose of the pins is to provide rough orientation of the frame and hence of the sensors. Since it is extremely difficult to devise a mounting system which automatically aligns the observatory to a few tens of arc seconds, the final orientation of the sensors would have to be measured *in situ* as described earlier. When service is required, the entire titanium frame with attached sensors is removed from the concrete base and recovered by a surface ship. This could be accomplished with the assistance of a manned submersible or ROV which would attach an elevator to the observatory, hence providing buoyancy to lift it to the surface. As an alternative, the Scripps thruster package could be used to connect a research vessel trawl wire to the observatory and allow it to be hoisted to the surface. Either approach would require careful design of the observatory frame so that the necessary acoustic homing beacons and lifting bails are incorporated and compatibility with a wide range of deep submergence vehicles is achieved. In fact, careful attention to the overall design to ensure compatibility with the broadest possible range of deep submergence assets is essential, and will require close consultation with submersible engineers.

It is probably not practical to replace individual sensors on the seafloor. Existing submersible and ROV technology does not possess the fine manipulative capability which would be required to handle this task unless each component is made very large, and it would then be very difficult to fit the requisite number of sensors on a $1.5 \times 1.5 \text{ m}$ surface. There is also an alignment issue here; each vector sensor would have to be capable of independently determining its absolute orientation if separate sensor replacement is anticipated, and this would prove quite costly. A simpler and more economic approach would be the inclusion of a fully redundant set of sensors mounted rigidly to the observatory frame with a known orientation as measured prior to deployment. As individual sensors fail, their backup units could be switched in by the observatory controller. This would require only that the absolute orientation of the entire observatory rather than that of each sensor be measurable *in situ*.

All of the observatory components which do not require absolute alignment (e.g., scalar magnetometer, data logger, master controller, and battery packs) can be mounted separately from the observatory mounting base and off to the side. These can then be cabled to the sensors on the base. This would allow replacement of the batteries or recovery of data without disturbing the ori-

entation of critical sensors.

Underwater electrical connectors are often a weak link in seafloor instrumentation, and careful design work will be required to provide redundancy and protect against major system failures due to faulty connectors. Underwater fiber optic technology is maturing rapidly, and should be seriously considered for applications such as data or control links where electrical energy is not being transferred due to their higher inherent reliability.

F. Logistical Issues

The logistics of installing and servicing a set of seafloor geomagnetic observatories poses a number of difficult issues associated with ship and submersible availability and capability that will have to be carefully examined. This is especially true of the most remote sites such as those in the Southern Ocean (see Table 1) because of the infrequency of research vessel activity in those parts of the globe.

It is difficult to envision installing or maintaining a seafloor geomagnetic observatory without the assistance of a manned submersible or ROV. This is especially true if an observatory consists of several subassemblies which are cabled together, and given the previous discussions on the required volume of batteries and the feasible size of a mounting base, this appears to be inevitable. However, the number of deep submergence assets available to the world oceanographic community is limited and unlikely to grow appreciably in the near future. Manned submersibles capable of reaching full ocean depth (at least 4500 m) include *Alvin* (US), *Nautile* (France), *Shinkai 6500* (Japan), and the two *Mirs* (Russia). In addition, the US Navy submersible *Sea Cliff* is sometimes available for scientific missions. Scientific ROVs with a full ocean depth capability include *Jason*, the soon-to-be-completed *Tiburón*, and the Scripps thruster/wireline re-entry system in the US and *Kaiko* in Japan. While additional ROVs exist in Canada, the US, and Japan, they cannot generally operate at a depth of 4 to 5 km where all of the observatory sites in Table 1 are located. All of these deep submergence assets are heavily utilized. This does not mean that they will be difficult to access for observatory purposes, but it should be realized that they are typically scheduled at least a year in advance, and hence it is unlikely that they will be available on short notice in the event that an observatory failure is detected. This argues strongly for the construction of geomagnetic observatories which are both autonomous and redundant in capability. It should also be noted that submersible activity has traditionally been concentrated in the North Atlantic Ocean and Mediterranean Sea, and North and Western Pacific Oceans, due largely to logistics, and they are rarely if ever scheduled in remote parts of the world oceans. This is especially true of manned submersibles, and will probably be less of an issue with ROVs which are presently less subscribed.

The logistical, instrumental, and scientific advantages of collocation of terrestrial field stations for seismology, geodesy, and geomagnetism were thoroughly discussed in *Geomagnetic Observatory Task Group* [1994], and has received considerable attention since that report appeared [e.g., Heirtzler et al., 1995]. The advantages of collocation are at least as strong for seafloor observatories; this is a major theme of the International Ocean Network program which is now being organized. Collocation offers major cost savings with respect to research vessel and submersible mobilization and transit costs which become more important as the observatory site becomes more remote. Technical advantages will also accrue from sharing infrastructure like power sources and communications systems. This is especially true if a geomagnetic observatory is collocated with a seismic component of the Ocean Seismic Network or its descendants because both

the power requirements and data rate for the former are much smaller than those of seismic systems. In fact, an ocean seismic observatory requires a near real-time data transmission capability because the volume of data exceeds that of any reasonable *in situ* storage medium. Note also that the high cost of submarine cable reuse probably precludes the installation of a single type of sensor, but becomes much more justifiable when its use crosses disciplinary boundaries and solves a variety of technical problems. Finally, it has already been noted that it is feasible to determine absolute direction on the seafloor using a modification of an existing seafloor geodetic technique employing precision acoustic transponders. Since this requires the absolute location of two closely-spaced seafloor points, a geomagnetic observatory using this method also serves as a component of a geodetic observatory and hence serves as a reference point distant from a tectonic plate boundary that is useful for plate deformation and kinematic studies.

Collocation is as much a management as it is a technical issue since the efforts of more than one discipline must be coordinated. Because of the inherent international nature of a seafloor geomagnetic observatory effort, this in turn becomes an exercise in international planning and management. It is premature to propose or construct an international framework to manage a seafloor geomagnetic observatory effort, but eventually this issue will have to be faced. Furthermore, the collocation issue virtually guarantees that the international management structure will have to consider a multidisciplinary seafloor observatory rather than a solely geomagnetic one. To this end, the International Ocean Network program has now included a geomagnetist in its steering committee, and can be expected to evolve into the necessary management group. This neither precludes nor replaces the need for a separate international technical group to set standards and procedures for seafloor geomagnetic observations, and such a committee will need to be established, probably under the purview of ION, as the planning for observatories matures.

G. A Conceptual Seafloor Observatory Design

In closing, it is a useful exercise to propose a conceptual seafloor geomagnetic observatory based on the discussions of this report, map out a construction timeline which would allow for any necessary engineering development, and provide cost estimates. It should be emphasized in advance that this is only one possible approach to the construction of an observatory, and is not intended to be exclusive or to ignore the advantages that may accrue as technologies change. To this end, only an autonomous observatory with *in situ* data storage will be considered because it applies to the largest possible number of sites. Furthermore, an approach which entails a minimum of engineering development and makes the maximum use of existing technology will be preferred over that requiring significant new instrument design. Thus, the acoustic-optical absolute direction technique will be considered rather than the absolute DI flux sensor because the former can be ready quickly and at a lower development cost. The absolute DI flux sensor is a very promising long term approach for both terrestrial and seafloor observatory applications, but does require (conservatively) 4 man-years of engineering effort plus associated costs approaching US\$0.5M. However, the north seeking gyroscope system should be considered for direction determination if it is both operational and proven when observatory construction begins.

Figure 9 shows a large scale cartoon of the seafloor geomagnetic observatory. The widely spaced pair of towers each contain two collocated precision acoustic transponders. The lower frequency (~10 kHz) version responds to interrogation from a GPS navigated surface ship and are used to fix the absolute locations of the towers in a global reference frame, yielding the strike of the baseline separating them. In the absence of differential motion of the towers from settling, this

needs to be done only once at the time the observatory is deployed. However, if the transponders are also part of an oceanic geodetic network, relocation on a roughly annual basis would be prudent. The second transponder on each tower operates at a frequency of ~50 kHz and responds to interrogation in turn from each of the short baseline pair of high frequency precision transponders located near the observatory base. As discussed in section 5, it is conservatively possible to measure the strike of the baseline separating the two closely spaced transponders with 30" or better absolute accuracy. The observatory base slab is then oriented relative to this baseline using laser rangefinders located at its four corners together with corner cube reflectors fixed to the transponder towers. Measurement of the short baseline strike angle can be repeated weekly for five years using internal transponder batteries. Similarly, the slab orientation can be determined at comparable intervals without significantly affecting the observatory energy budget.

Figure 10 shows a cartoon detailing the sensors, recording and control package, and battery packs for the seafloor observatory. A titanium frame is located on the concrete base slab by four titanium pins; these are tapered to provide as rigid a lock as possible commensurate with making the frame removable without moving the slab. A fully redundant set of vector sensors, including triaxial XYZ magnetometers, two axis tilt detectors, and automatic DI flux sensors, and a pair of scalar magnetometers, are fixed to the titanium frame with known orientations. Laser rangefinders are located at the four corners of the titanium frame. A separate package containing the master controllers for the observatory, the master clocks, redundant data storage with a 5 year capacity, and a pair of seafloor acoustic modems is placed a short distance away on the seafloor and connected to the observatory base by an electro-optical tether. A third seafloor package containing a set of 9" id by 3' pressure cases holds sufficient lithium batteries to power the observatory for 5 years with a reserve margin to allow for battery failures, and is connected by cable to the remaining pressure cases.

The actual mix of sensors can be varied, but is constrained by the power budget. As noted in section 5, the power savings that accrue by using suspended magnet variometers instead of vector fluxgate sensors is substantial, and results in about a factor of two reduction in the battery count. Given that the fluxgate offers few performance advantages, this makes the variometer the vector sensor of choice for an observatory. Similarly, the two tilt sensors require very little power, essentially being limited to that required to energize the light emitting diode source. The pair of DI flux sensors operate at a much higher power level, and significant energy savings might accrue if these are operated in turn rather than in parallel. The four servoed laser rangefinders have little impact on the energy budget. Finally, the pair of scalar magnetometers consume only limited energy due to the relatively long duty cycle. Overall, the consumption of the sensors on the observatory slab amounts to just under one watt assuming that everything is running. This could be reduced to 0.7 watts by operating only one of the DI flux instruments at a time. The external electronics package can easily operate at less than 0.3 watts, and hence the overall observatory power consumption is of order one watt. This would be closer to two watts if vector fluxgate sensors are used.

Table 4 gives rough estimates for the acquisition costs of the major observatory components excluding any development and integration engineering, expendable supplies like batteries, or installation costs. Engineering costs are particularly difficult to estimate, but for the first observatory, will probably amount to 100% of the fabrication cost.

It would be prudent to plan for a two year development and testing effort prior to observatory installation. The only major observatory component which requires testing in the ocean would be the absolute direction system because it involves a new application of precision acoustic transponders and their integration with optical range finding technology. Installation of the first obser-

vatory should be planned for year three.

It makes little sense to install the first seafloor geomagnetic observatory in a remote part of the world because the chance of failure is higher at the beginning. Perhaps the best sites in the list in Table 1 are WP1 and NA1 because they lie in close proximity to the most interested countries and hence could more easily be visited by a research vessel for monitoring or repair.

Table 4: Major Observatory Component Acquisition Costs

Component	Cost (US\$)
2x 3 component magnetic variometers	20K
2x automatic DI flux	100K
2x biaxial tilt sensor	20K
4x laser range finder	40K
2x Overhauser scalar magnetometer	16K
Master controller and clock	10K
2x data logger	10K
2x seafloor acoustic modem	20K
Titanium pressure cases and frame	100K
6x precision acoustic transponders	120K
4x transponder towers	40K
Total	496K

References

- Barker, F.S., and D.R. Barraclough, The effects of the non-uniform distribution of magnetic observatory data on secular variation models, *Phys. E. Pl. Int.*, 37, 65-73, 1985.
- Chave, A.D., On the electromagnetic fields induced by oceanic internal waves, *J. Geophys. Res.*, 89, 10519-10528, 1984.
- Chave, A.D., and D.S. Luther, Low-frequency, motionally induced electromagnetic fields in the ocean, 1, theory, *J. Geophys. Res.*, 95, 7185-7200, 1990.
- Chave, A.D., S.C. Constable, and R.N. Edwards, Electrical exploration methods for the seafloor, in M.N. Nabighian (ed.), *Electromagnetic Methods in Applied Geophysics*, Vol. 2, Tulsa: Society of Exploration Geophysicists, 931-966, 1991.
- Chave, A.D., D.S. Luther, L.J. Lanzerotti, and L.V. Medford, Geoelectric field measurements on a planetary scale: oceanographic and geophysical applications, *Geophys. Res. Lett.*, 19, 1411-1414, 1992.
- Coles, R.L. (ed.), Proceedings of the International Workshop on Magnetic Observatory Instruments, *Geol. Surv. Canada Paper 88-17*, 94 pp., 1988.
- Filloux, J.H., Instrumentation and experimental methods for oceanic studies, in J.A. Jacobs (ed.), *Geomagnetism*, Vol. 1, New York: Academic Press, 143-248, 1987.
- Geomagnetic Observatory Task Group, *An enhanced geomagnetic observatory network*, a report to the US Geodynamics Committee, National Research Council, 62 pp., 1994.
- J.R. Heirtzler, R.A. Langel, R. Baldwin, A.D. Chave, J.J. Frawley, and A.W. Green, Jr., Proposed geomagnetic observatories co-located with other geophysical stations, *Proc. 21st General Assembly of the International Union of Geodesy and Geophysics*, Boulder, CO, 2-14 July 1995.
- INTERMAGNET, *INTERMAGNET Technical Reference Manual*, 73 pp., 1994.
- Johnson, H.P., and J.E. Pariso, Variations in ocean crustal magnetization: systematic changes in the last 160 million years, *J. Geophys. Res.*, 98, 435-445, 1993.
- Langel, R.A., R.T. Baldwin, and A.W. Green, Toward an improved distribution of geomagnetic observatories for modeling of the main geomagnetic field and its temporal change, *J. Geomagn. Geoelectr.*, in press, 1995.
- Lanzerotti, L.J., A.D. Chave, C.H. Sayres, L.V. Medford, and C.G. MacLennan, Large-scale electric field measurements on the earth's surface: a review, *J. Geophys. Res.*, 98, 23,525-23,534, 1993.

- Lilley, F.E.M., J.H. Filloux, P.J. Mulhearn, and I.J. Ferguson, Magnetic signals from an ocean eddy, *J. Geomagn. Geoelectr.*, 45, 403-422, 1993.
- McLean, S.J., W.M. Davis, L.D. Morris, and H. Meyers, *A Report on Geomagnetic Observatories and Observations, 1994*, National Geophysical Data Center, US Department of Commerce, 143 pp., 1994.
- Narod, B.B., and R.D. Russell, *IEEE Trans.*, MAG-20, 592-597, 1984.
- National Geomagnetic Initiative, *The National Geomagnetic Initiative*, Washington D.C.: National Academy Press, 246 pp., 1993.
- Peddie, N.W., Magnetic observatory coverage and the reliability of secular-variation models, informal report, US Geological Survey, 1992.
- Russell, R.D., B.B. Narod, and F. Kollar, *IEEE Trans.*, MAG-19, 126-130, 1983.
- Spiess, F. N., D. E. Boegeman, F. V. Pavlicek, and C. D. Lowenstein, Precision transponder and method of communication therewith; U. S. Patent 4,214,314, July 22, 1980.
- Spiess, F. N.; Suboceanic geodetic measurements; *IEEE Trans. Geosci. Rem. Sens.*, GE -23, 502-510, 1985.
- Stuart, W.F. (ed.), Geomagnetic observatory and survey practice, *Geophys. Surv.*, 6 (3/4), 464 pp., 1984.
- Tivey, M.A., High-resolution magnetic surveys over the Middle Valley mounds, northern Juan de Fuca Ridge, in Mottl, M.J., E.E. Davis, and J.F. Slack (eds.), *Proc. Ocean Drill. Prog.*, 139, 29-35, 1994.
- Tivey, M.A., and H.P. Johnson, Variations in oceanic crustal structure and implications for the fine-scale magnetic anomaly signal, *Geophys. Res. Lett.*, 20, 1879-1882, 1993.
- Widrow, B., and S.D. Stearns, *Adaptive Signal Processing*, Englewood Cliffs: Prentice Hall, 474 pp., 1985.

Figure 1. Magnetic observatories active during some part of the interval 1818-1994, as determined from data archived at the World Data Center A. Green dots indicate observatories which are currently active, red dots indicate observatories whose present status is in question, and open circles indicate observatories which are not presently active (taken from *McLean et al., 1994*).

Figure 2. The locations of all geomagnetic observatories active in 1994 with 1000 km radius circles drawn surrounding them. Only one circle is shown when stations are very close together. INTERMAGNET stations are shown with solid symbols, while other stations are shown as open symbols. The top and bottom maps are Mollweide projections centered about the Greenwich and 180th meridians, respectively, and the middle pair of maps are polar projections (taken from *Geomagnetic Observatory Task Group, 1994*).

Figure 3. The locations of new geomagnetic observatories proposed by *Geomagnetic Observatory Task Group [1994]* with 1000 km radius circles drawn surrounding them. The open triangles are stations located on continents or islands, while the solid triangles indicate the seafloor observatories listed in Table 1. The top and bottom maps are Mollweide projections centered about the Greenwich and 180th meridians, respectively, and the middle pair of maps are polar projections (taken from *Geomagnetic Observatory Task Group, 1994*).

Figure 4. The ratio of the horizontal electric (top panel) and horizontal magnetic (bottom panel) fields at the sea surface to that at the seafloor as a function of period in the plane wave (i.e., magnetotelluric) limit. The earth is modeled as an insulating atmosphere overlying an ocean of conductivity 3.2 S/m and thickness as given, and underlain by a halfspace of conductivity 0.05 S/m (solid lines) or 0.005 S/m (dashed lines). Attenuation of the vertical magnetic field is similar to that of the electric field (taken from *Chave et al., 1991*).

Figure 5. Diagram indicating the principle of operation for suspended magnet variometer sensors utilizing electro-optical feedback, as developed by *Filloux [1987]*. An infrared light source generates a light beam which is focussed by a condensing lens system onto a mirror attached to a bar magnet suspended on a fine tungsten fiber and immersed in oil. The incident beam travels through a narrow slit in front of the condensing lenses and then through an objective close to the mirror. The reflected beam crosses the objective and forms an image of the slit on a twin photodiode array operated in a differential mode. If the normal to the mirror does not coincide with the optical axis of the system, the slit image is off center and the light sensor output is not null. The output of the light sensor is used to control a current sent through a coil which generates a magnetic field normal to the magnet, whose torque twists the suspension until the light beam is centered on the photodiode array. Thus, the current through the coil is a measure of the magnetic field normal to the mirror that acts on the magnet (taken from *Filloux, 1987*).

Figure 6. A conceptual seafloor geomagnetic observatory based on the absolute DI flux sensor described in the text. The observatory instruments are mounted on a slab base. The automatic DI flux sensor is shown at the front left, while a gyrocompass to measure the true north direction is shown at the front right. Directional information is sent between them optically using an autocollimator, while the bases of both sensors are gimballed. Pressure cases are not shown.

Figure 7. Conceptual diagram showing an automatic DI flux sensor. A non-magnetic gyroscope is shown at the top. A biaxial fluxgate sensor is mounted immediately below, and can be oriented using non-magnetic motors. The base is gimballed so that the entire unit can be leveled and moved azimuthally.

Figure 8. Sketch of a three-axis tilt sensor based on optical principles developed for seafloor applications requiring a stable baseline. The third component of tilt (rotation about the vertical) is measured by detecting the D component of the geomagnetic field and removing magnetic field fluctuations with a remote magnetometer, and is not relevant to an observatory application. The other tilt components are detected by focusing the image of a slit onto a mirror fixed to the bottom of a brass plumb bob which is suspended from a tungsten fiber and immersed in oil. The slit image is reflected onto a quad photodiode array operated in a differential mode which yields the two components of tilt about horizontal axes. The entire unit is gimballed for rough centering.

Figure 9. Cartoon showing a large scale view of a conceptual seafloor geomagnetic observatory. The primary towers at left and right are spaced about 4 km apart and contain pairs of precision acoustic transponders operating near 10 and 50 kHz, respectively. The lower frequency version can be interrogated from a surface ship whose position is known from GPS navigation, and hence the azimuth of the baseline separating the towers can be measured with about 10" of arc accuracy as described in the text. The secondary towers in the middle are separated by about 30 m, and contain 50 kHz precision transponders which range on the high frequency transponders on the primary towers. This yields the azimuth of the baseline separating them to about 30" of arc accuracy using the procedure described in the text. The slab located between the secondary towers contains the observatory magnetic field sensors, as detailed in Figure 10.

Figure 10. Cartoon showing the center of the conceptual seafloor geomagnetic observatory shown in Figure 9. The concrete slab located between the two secondary transponder towers contains instrumentation mounted on a removable titanium sled. This includes redundant three component suspended magnet variometers, absolute intensity sensors, and automatic DI flux sensors. The slab is oriented relative to the secondary towers using servoed laser rangefinders located at the four corners of the slab which reflect their light beams off of corner cubes located on the towers. The observatory controller, data logger, and acoustic modems to transmit data to a surface ship are located a short distance to one side and connected to the instrumentation slab by an electro-optical cable. A battery pack containing sufficient lithium batteries to power the observatory is located near the controller and linked to it by an electric cable. See text for discussion.

Magnetic Observatories 1818 - 1994

(based on data received at the WDC-A)

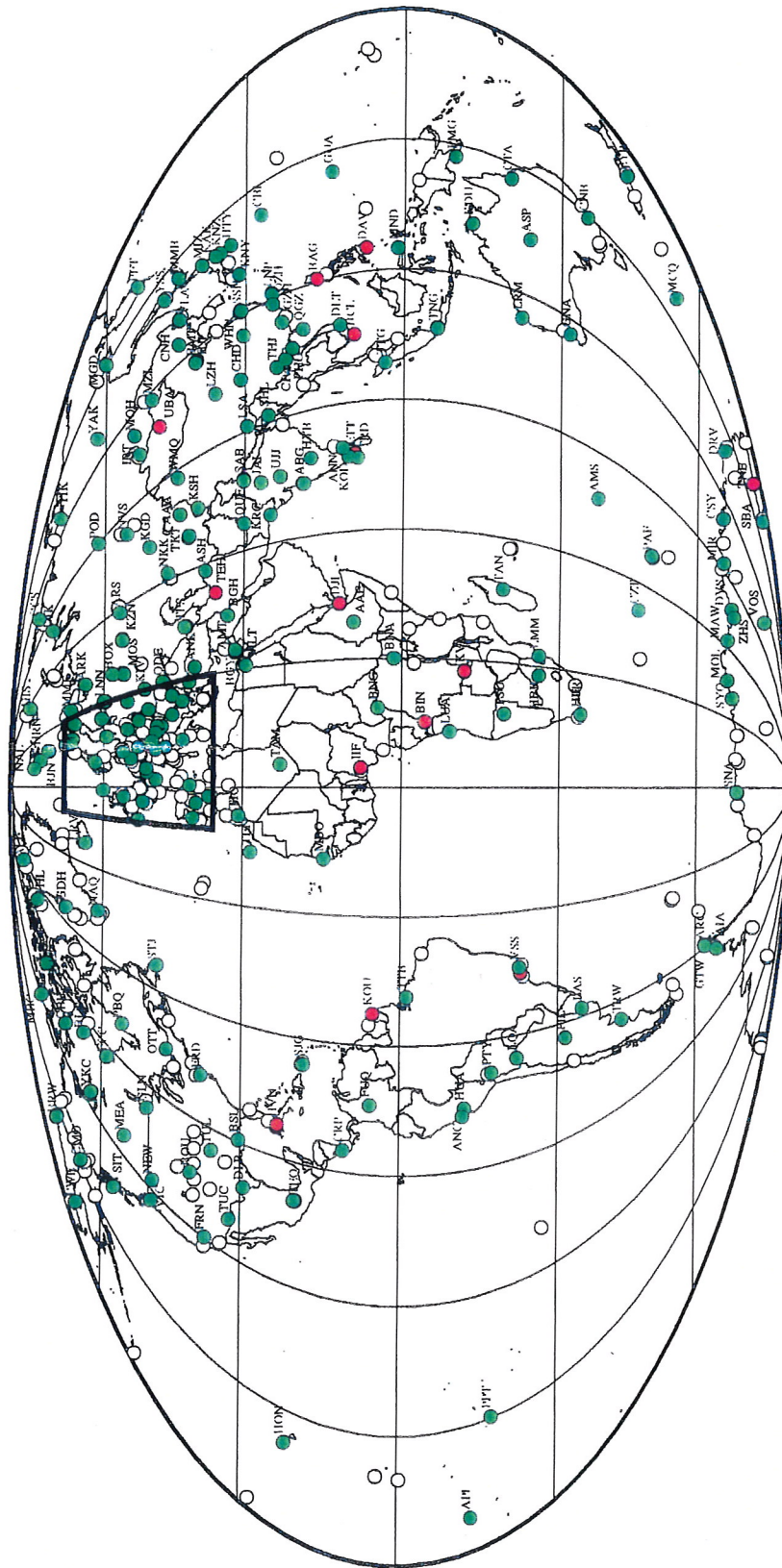

- Observatory status uncertain
- Observatory operating
- Observatory closed

Figure 1

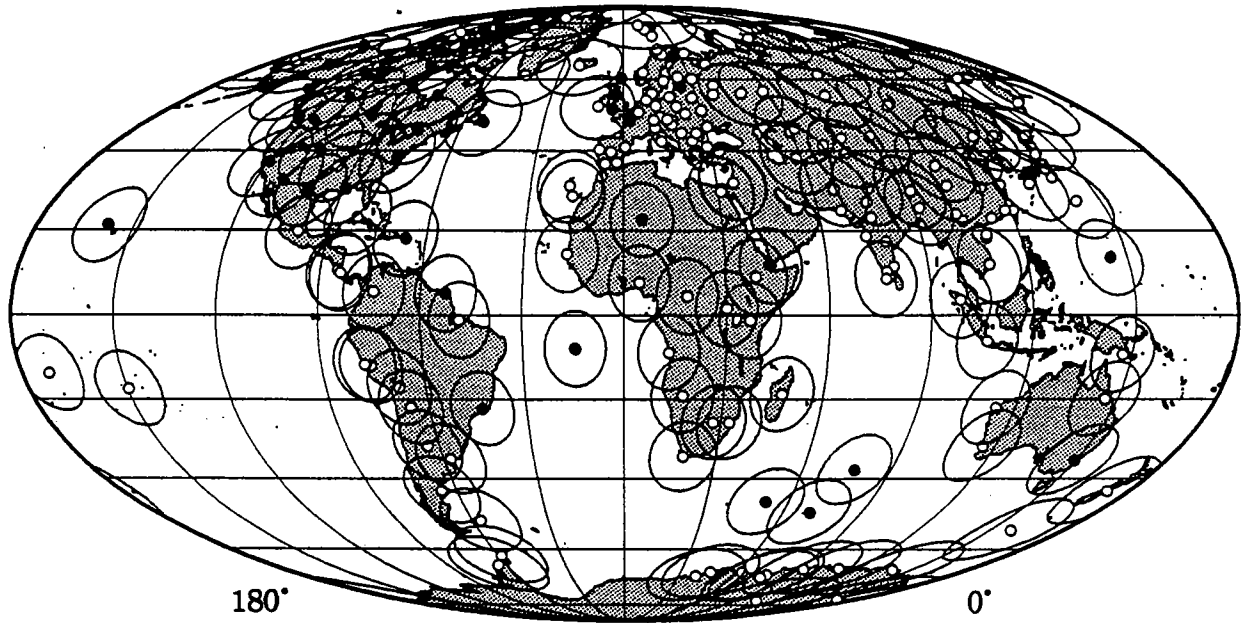

180°

0°

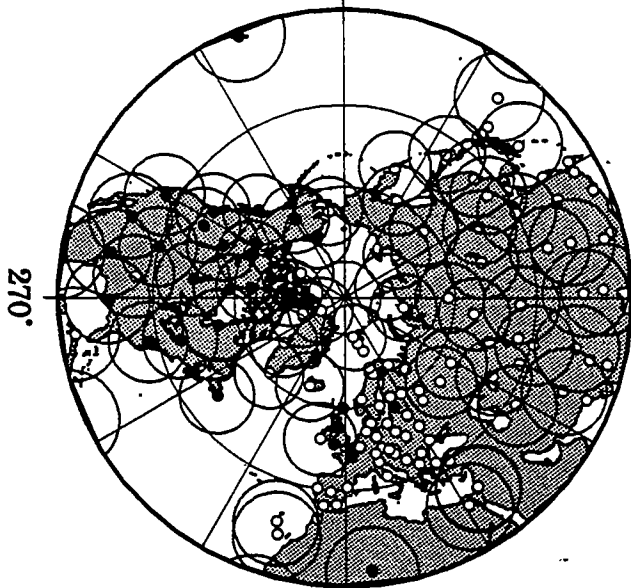

270°

90°

270°

0°

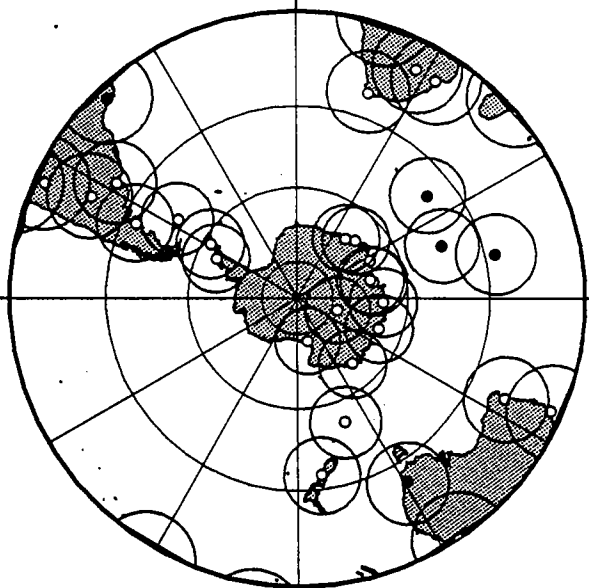

90°

180°

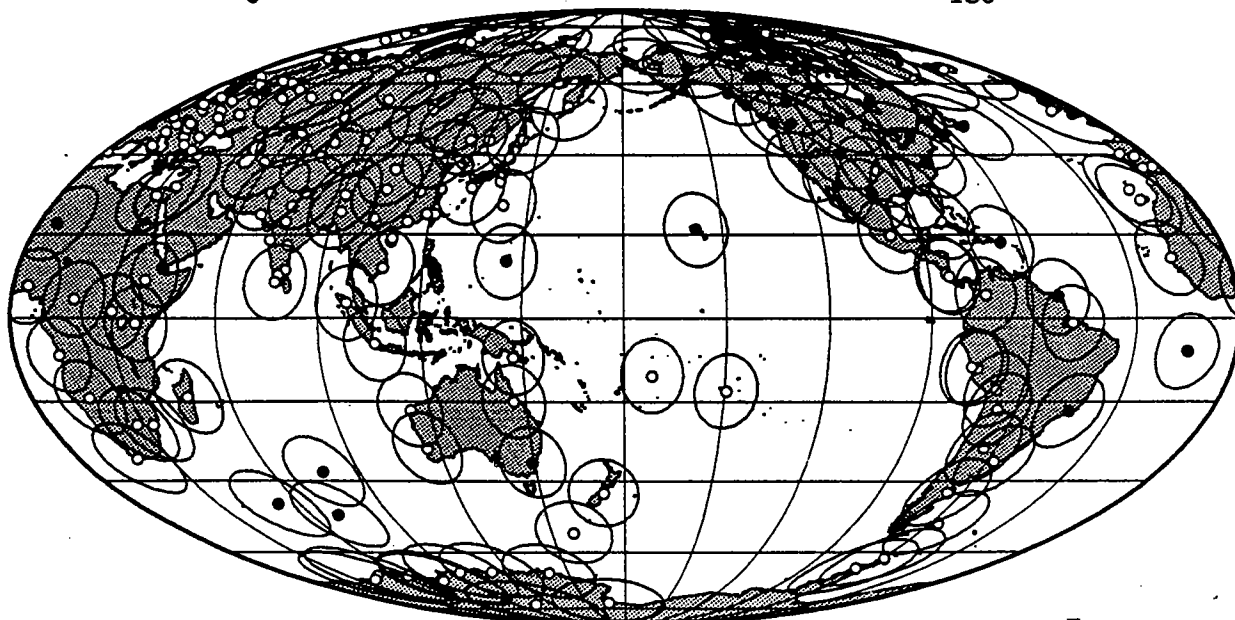

Figure 2

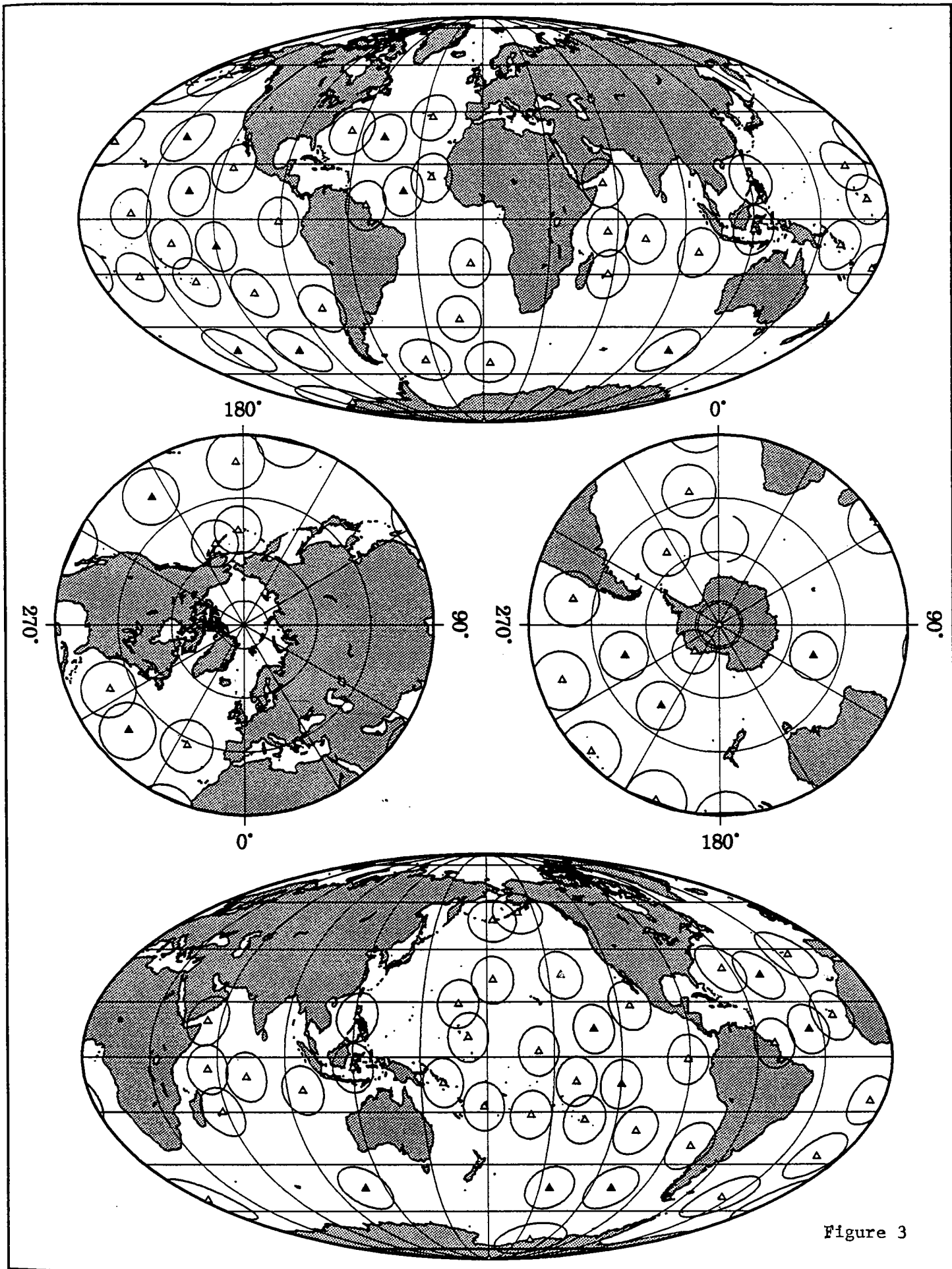

Figure 3

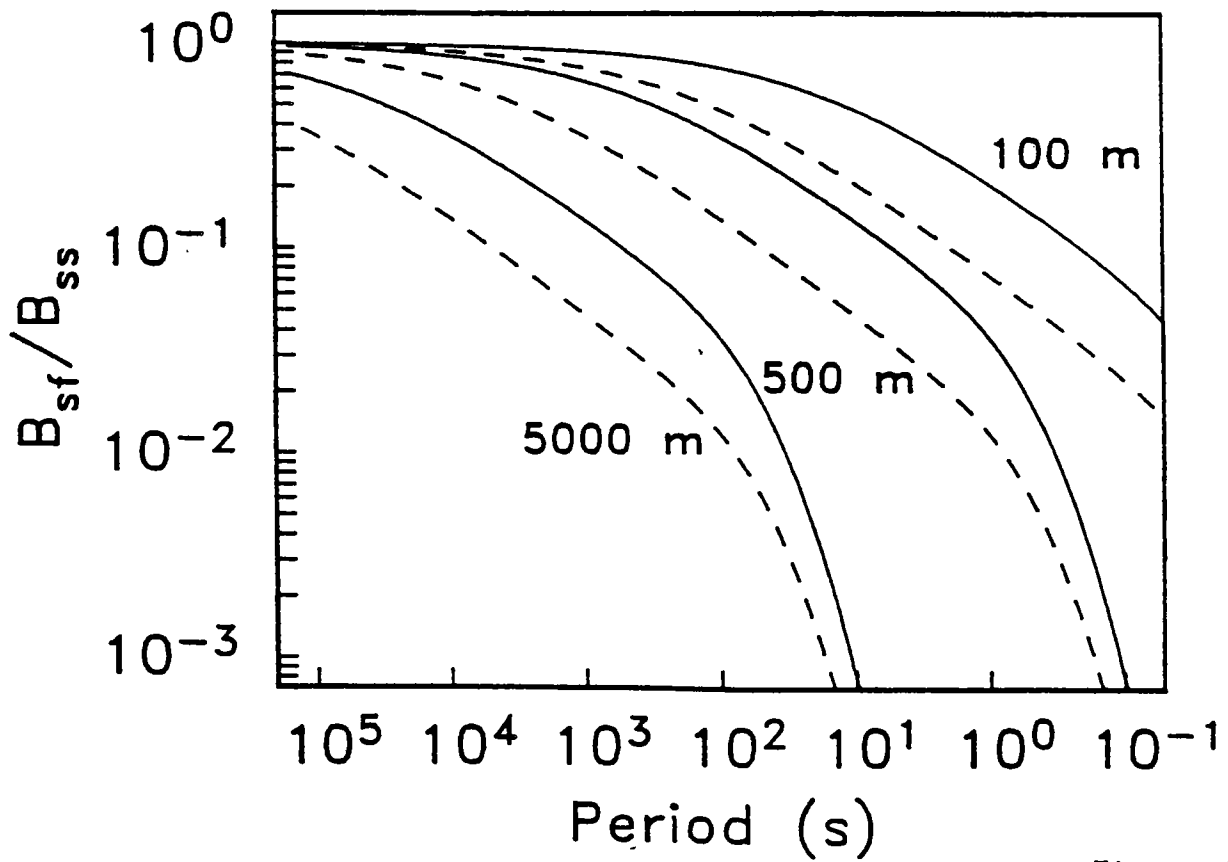
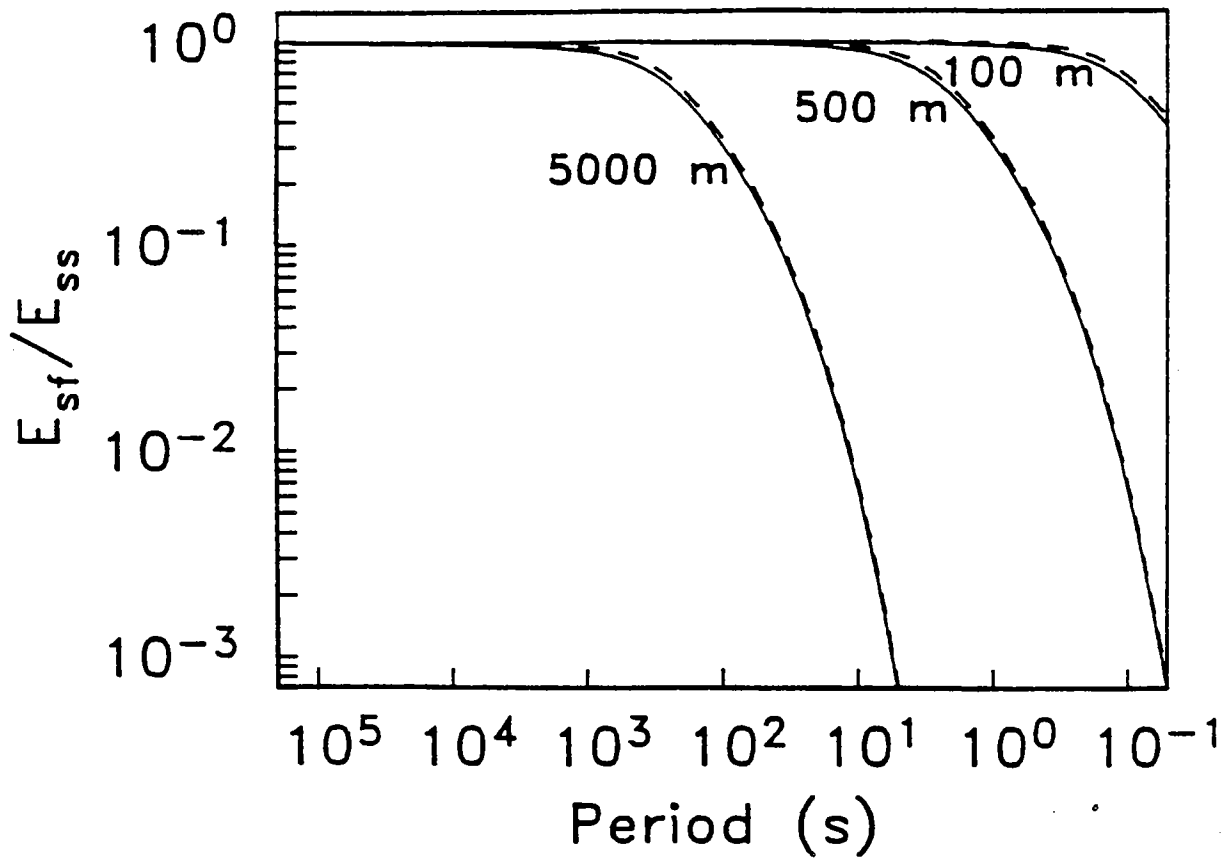

Figure 4

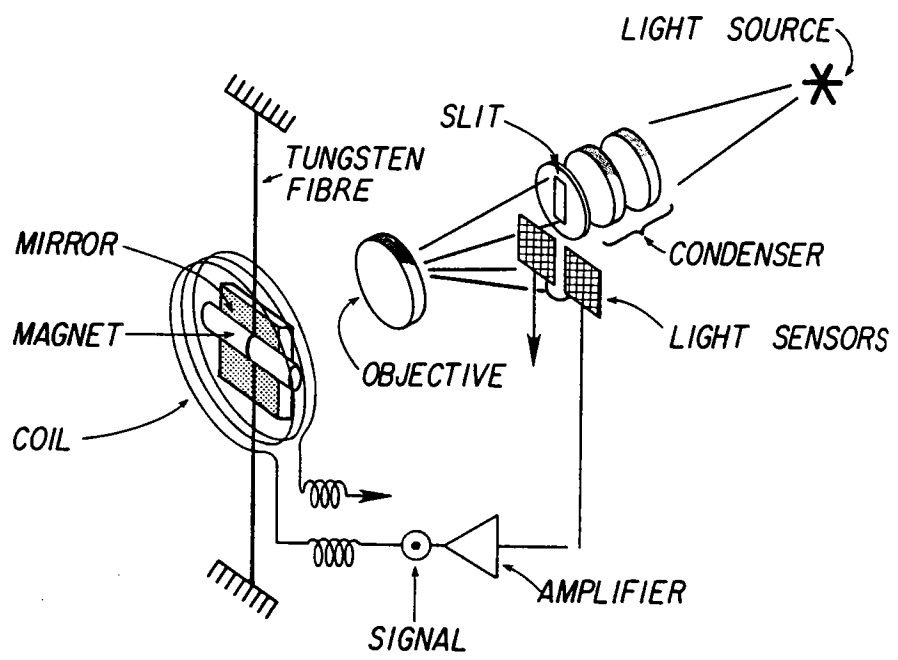

Figure 5

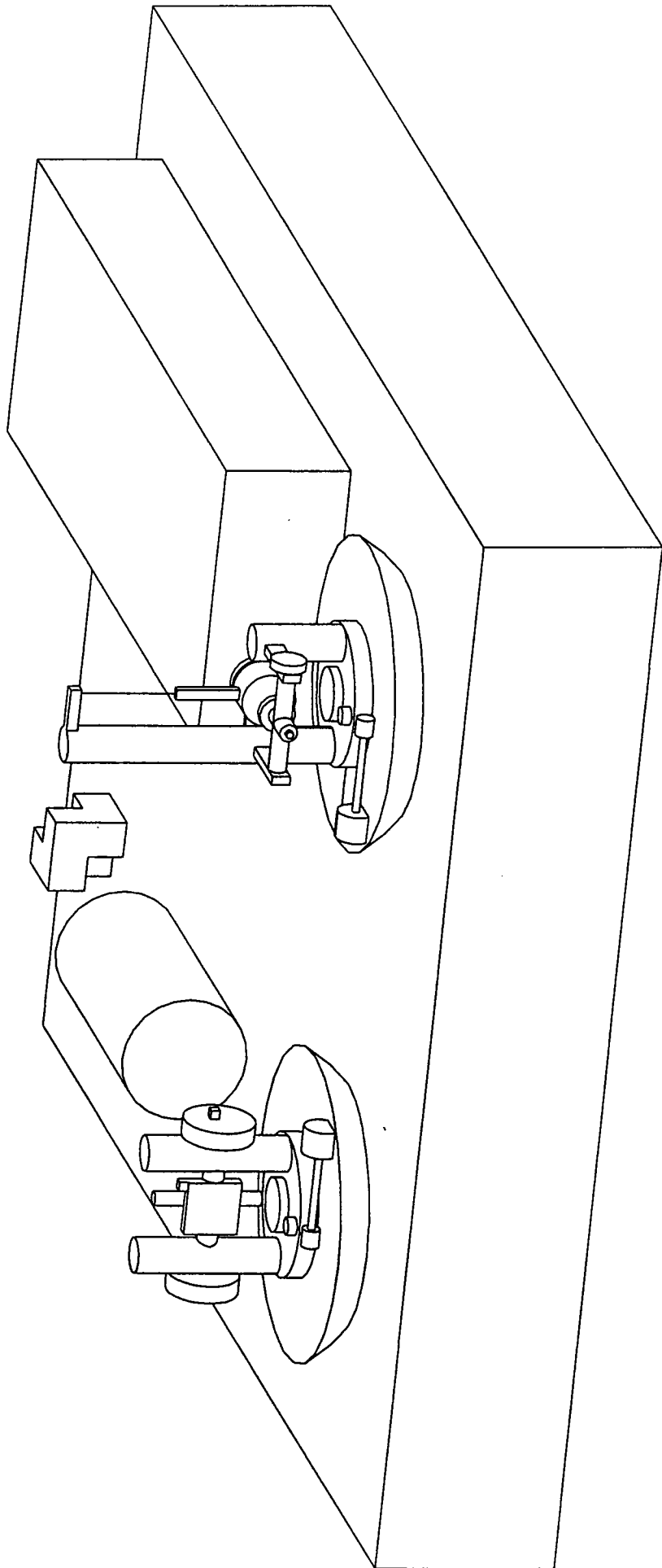

Figure 6

REPORT DOCUMENTATION PAGE	1. REPORT NO. WHOI-95-12	2.	3. Recipient's Accession No.
4. Title and Subtitle Report of a Workshop on Technical Approaches to Construction of a Seafloor Geomagnetic Observatory			5. Report Date September 1995
			6.
7. Author(s) Alan D. Chave, Arthur W. Green, Jr., Rob L. Evans, Jean H. Filloux, Lawrie K. Law, Robert A. Pettitt, Jr., Jean L. Rasson, Adam Schultz, Fred N. Spiess, Pascal Tarits, Maurice Tivey, Spahr C. Webb			8. Performing Organization Rept. No. WHOI-95-12
9. Performing Organization Name and Address Woods Hole Oceanographic Institution Woods Hole, Massachusetts 02543			10. Project/Task/Work Unit No.
			11. Contract(C) or Grant(G) No. (C) EAR94-21712 (G)
12. Sponsoring Organization Name and Address National Science Foundation			13. Type of Report & Period Covered Technical Report
			14.
15. Supplementary Notes This report should be cited as: Woods Hole Oceanog. Inst. Tech. Rept., WHOI-95-12.			
16. Abstract (Limit: 200 words) This report considers the technical issues on sensors, data recording and transmission, control and timing, power, and packaging associated with constructing a seafloor geomagnetic observatory. Existing technologies either already in use for oceanographic purposes or adapted from terrestrial geomagnetic observatories could be applied to measure the vector magnetic field components and absolute intensity with minimal development. The major technical challenge arises in measuring absolute direction on the seafloor because terrestrial techniques are not transferrable to the deep ocean. Two solutions to this problem were identified. The first requires the development of an instrument which measures the instantaneous declination and inclination of the magnetic field relative to a north-seeking gyroscope and the local vertical. The second is a straightforward extension of a precision acoustic method for determining absolute position on the seafloor.			
17. Document Analysis			
a. Descriptors geomagnetic observatory seafloor instrumentation long-term observations			
b. Identifiers/Open-Ended Terms			
c. COSATI Field/Group			
18. Availability Statement Approved for public release; distribution unlimited.		19. Security Class (This Report) UNCLASSIFIED	21. No. of Pages 47
		20. Security Class (This Page)	22. Price