

Technical Report

April 1998



---

## Pan American Climate Study (PACS)

Mooring Deployment Cruise Report  
*R/V Roger Revelle* Cruise Number Genesis 4  
9 April - 5 May 1997

by

Bryan S. Way  
William M. Ostrom  
Robert A. Weller  
Jonathan D. Ware  
Richard P. Trask  
Rick Cole  
Jeff Donovan

April 1998



Upper Ocean Processes Group  
Woods Hole Oceanographic Institution  
Woods Hole, Massachusetts 02543  
UOP Technical Report 98-01



WHOI-98-07

UOP-98-01

**Pan American Climate Study (PACS)  
Mooring Deployment Cruise Report  
R/V *Roger Revelle* Cruise Number Genesis 4  
9 April - 5 May 1997**

by

Bryan S. Way  
William M. Ostrom  
Robert A. Weller  
Jonathan D. Ware  
Richard P. Trask  
Rick Cole  
Jeff Donovan

**Technical Report**

Woods Hole Oceanographic Institution  
Woods Hole, Massachusetts 02543

April 1998

Funding was provided by the National Oceanic and Atmospheric Administration under  
Contract No. NA66GPO130.

Reproduction in whole or in part is permitted for any purpose of the United States  
Government. This report should be cited as Woods Hole Oceanog. Inst. Tech. Rept.,  
WHOI-98-07.

Approved for public release; distribution unlimited.

**Approved for Distribution:**

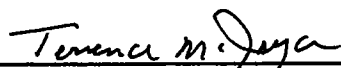

Terrence M. Joyce, Chair

Department of Physical Oceanography





## Abstract

Three surface moorings were deployed in the eastern equatorial Pacific from the R/V *Roger Revelle* as part of the Pan American Climate Study (PACS). PACS is a NOAA-funded study with the goal of investigating links between sea surface temperature variability in the tropical oceans near the Americas and climate over the American continents. The three moorings were deployed near 125°W, spanning the strong meridional sea surface temperature gradient associated with the cold tongue south of the equator and the warmer ocean north of the equator, near the northernmost, summer location of the Intertropical Convergence Zone. The mooring deployment was done to improve understanding of the air-sea fluxes and of the processes that control the evolution of the sea surface temperature field in the region.

Two surface moorings of the Upper Ocean Processes Group at the Woods Hole Oceanographic Institution (WHOI) were deployed—one at 3°S, 125°W and the other at 10°N, 125°W. One mooring from the Ocean Circulation Group (R. Weisberg) at the University of South Florida (USF) was deployed on the equator at 128°W.

The buoys of the two WHOI moorings were each equipped with meteorological instrumentation, including a Vector Averaging Wind Recorder, and an Improved METeoro-logical (IMET) system. The WHOI moorings also carried Vector Measuring Current Meters, single-point temperature recorders, and conductivity and temperature recorders located in the upper 200 meters of the mooring line. In addition to the instrumentation noted above, a variety of other instruments, including an acoustic current meter, acoustic doppler current meters, bio-optical instrument packages and an acoustic rain gauge, were deployed during the PACS field program. The USF mooring had an IMET system on the surface buoy and for oceanographic instrumentation, two RD Instruments acoustic doppler current profilers, single-point temperature recorders, and conductivity and temperature recorders. Conductivity-temperature-depth (CTD) profiles were made at each mooring site and during the transit between mooring locations.

This report describes, in a general manner, the work that took place during the Genesis 4 cruise aboard the R/V *Roger Revelle*. The three surface moorings deployed during this cruise will be recovered and re-deployed after approximately nine months, with a final recovery planned for 17 months after the first setting. Details of the mooring designs and preliminary data from the CTD profiles are included.



## Table of Contents

ABSTRACT.....	1
LIST OF FIGURES.....	4
LIST OF TABLES.....	5
SECTION 1: INTRODUCTION.....	6
SECTION 2: THE MOORED ARRAY.....	6
A. WHOI SURFACE MOORINGS.....	11
1. WHOI Meteorological Instrumentation.....	14
a. Vector Averaging Wind Recorder.....	14
b. Improved METeorological System.....	14
c. Stand-alone Relative Humidity/Temperature Instrument.....	24
2. Sub-surface Instrumentation.....	24
a. Buoy Tension Recorder.....	24
b. Sub-surface Argos Transmitter.....	29
c. SEACAT Conductivity and Temperature Recorders.....	29
d. MicroCAT Conductivity and Temperature Recorder.....	29
e. Brancker Temperature Recorders.....	29
f. Miniature Temperature Recorder.....	30
g. Vector Measuring Current Meters.....	30
h. WaDaR Temperature Recorder.....	30
i. Falmouth Scientific Instruments Current Meter.....	31
j. Davis/Shernan Current Meter.....	31
k. Chlorophyl Absorption Meter.....	31
l. Acoustic Rain Gauge.....	31
m. Acoustic Release.....	32
B. USF SURFACE MOORING AND INSTRUMENTATION.....	32
C. SHIPBOARD METEOROLOGICAL SYSTEM.....	33
SECTION 3: CRUISE CHRONOLOGY.....	36
ACKNOWLEDGMENTS.....	44
REFERENCES.....	44
APPENDIX 1: CRUISE PARTICIPANTS.....	45
APPENDIX 2 CTD TEMPERATURE, SALINITY AND DENSITY PROFILES.....	46
APPENDIX 3: WHOI INSTRUMENTATION DEPLOYED DURING PACS 1.....	60
APPENDIX 4 WHOI VMCM RECORD FORMAT.....	63
APPENDIX 5: PACS MOORING DEPLOYMENT PROCEDURES.....	64
APPENDIX 6: PACS ANTIFOULING COATING TEST.....	71

## List of Figures

FIGURE 1: PACS 1 MOORING CRUISE SCHEDULE.....	7
FIGURE 2: CRUISE TRACK AND MOORING LOCATIONS.....	7
FIGURE 3: CTD PROFILE LOCATIONS.....	8
FIGURE 4: PACS MOORED ARRAY INSTRUMENT LOCATIONS.....	10
FIGURE 5: WHOI PACS SOUTH MOORING SCHEMATIC.....	12
FIGURE 6: WHOI PACS NORTH MOORING SCHEMATIC.....	13
FIGURE 7: AERIAL VIEW OF METEOROLOGICAL INSTRUMENTATION.....	15
FIGURE 8: SOUTH BUOY SPIN ORIENTATION.....	19
FIGURE 9: NORTH BUOY SPIN ORIENTATION.....	20
FIGURE 10: SOUTH BUOY SPIN DATA PLOT.....	21
FIGURE 11: NORTH BUOY SPIN DATA PLOT.....	21
FIGURE 12: SOUTH DISCUS SUB-SURFACE PROFILE.....	27
FIGURE 13: NORTH DISCUS SUB-SURFACE PROFILE.....	28
FIGURE 14 : USF MOORING SCHEMATIC AND BUOY PROFILE.....	34
FIGURE 15: BOW-MOUNTED IR SST ELEVATION.....	35
FIGURE 16: PACS SOUTH SURVEY BATHYMETRY GRID.....	38
FIGURE 17: PACS SOUTH ANCHOR POSITION SURVEY.....	39
FIGURE 18: PACS NORTH SURVEY BATHYMETRY GRID.....	41
FIGURE 19: PACS NORTH ANCHOR POSITION SURVEY.....	43
FIGURE A2-1: COMPOSITE PLOT OF CTD DATA.....	47
FIGURE A2-2: PROFILES OF POTENTIAL TEMPERATURE, SALINITY, AND SIGMA-T FROM CTD STATIONS 1 AND 2.....	48
FIGURE A2-3: PROFILES FROM CTD STATIONS 3 AND 4.....	49
FIGURE A2-4: PROFILES FROM CTD STATIONS 5 AND 6.....	50
FIGURE A2-5: PROFILES FROM CTD STATIONS 7 AND 8.....	51
FIGURE A2-6: PROFILES FROM CTD STATIONS 9 AND 10.....	52
FIGURE A2-7: PROFILES FROM CTD STATIONS 11 AND 12.....	53
FIGURE A2-8: PROFILES FROM CTD STATIONS 13 AND 14.....	54
FIGURE A2-9: PROFILES FROM CTD STATIONS 15 AND 16.....	55
FIGURE A2-10: PROFILES FROM CTD STATIONS 17 AND 18.....	56
FIGURE A2-11: PROFILES FROM CTD STATIONS 19 AND 20.....	57
FIGURE A2-12: PROFILES FROM CTD STATIONS 21 AND 22.....	58
FIGURE A2-13: PROFILES FROM CTD STATIONS 23 AND 24.....	59
FIGURE A5-1: PACS DEPLOYMENT DECK LAYOUT.....	65
FIGURE A5-2: PERSONNEL WORK STATIONS DURING SURFACE BUOY DEPLOYMENTS.....	66
FIGURE A5-3: UOP DISCUS BAIL CONFIGURATION.....	69
FIGURE A6-1: ANTIFOULING PAINT TEST LOCATIONS ON THE PACS NORTH AND SOUTH DISCUS BUOY HULLS.....	72



## List of Tables

TABLE 1: PACS MOORING DEPLOYMENT INFORMATION.....	8
TABLE 2: CTD STATIONS OCCUPIED DURING GENESIS 4.....	9
TABLE 3: METEOROLOGICAL SENSOR SERIAL NUMBERS PACS WHOI DISCUS BUOYS.....	16
TABLE 4: SOUTH IMET AND VAWR COMPASS/VANE LISTINGS.....	17
TABLE 5: NORTH IMET AND VAWR COMPASS/VANE LISTINGS.....	18
TABLE 6: VAWR SENSOR SPECIFICATIONS.....	22
TABLE 7: IMET SENSOR SPECIFICATIONS.....	23
TABLE 8: PACS SOUTH BUOY SENSOR ELEVATIONS.....	25
TABLE 9 : PACS NORTH BUOY SENSOR ELEVATIONS.....	26
TABLE A5-1: PACS MOORING PAYOUT SPEED CHART.....	70

## Section 1: Introduction

The fourth leg of the R/V *Roger Revelle*'s first science expedition, Genesis 4, departed Callao, Peru, on April 9, 1997, at 1930 hours local time (0030 UTC, April 10, 1997.) The purpose of the cruise was to deploy three surface moorings in the eastern, equatorial Pacific. In addition to setting the three moorings, CTD profiles were taken at each mooring location and along 125°W. A turnaround cruise is planned for January 1998 and a final recovery cruise for August 1998. The mooring deployment schedule is shown in Figure 1.

The cruise involved personnel from the Upper Ocean Processes (UOP) Group at the Woods Hole Oceanographic Institution (WHOI), and the Ocean Circulation Group at the University of South Florida (USF). The science party also included two volunteers from the University of Colorado, one volunteer from the National Center for Atmospheric Sciences; and two volunteers who were freelance journalists. Appendix 1 lists the cruise participants. Figure 2 shows the cruise track and mooring locations. Table 1 lists the positions of the moorings deployed during this cruise.

The locations of the CTD profiles are shown in Figure 3 and listed in Table 2. Appendix 2 shows the temperature, salinity, and density profiles for each station.

In addition to this introduction, this report has three sections. The second section primarily describes the WHOI and USF moorings and their instrumentation and the third section presents a chronology of the cruise.

## Section 2: The Moored Array

Three moorings were deployed during cruise Genesis 4 of the R/V *Roger Revelle*. The north and south moorings in the array were WHOI/ UOP group surface moorings with meteorological and oceanographic instrumentation.

Each of the buoys of the two WHOI moorings were equipped with meteorological instrumentation, including a vector averaging wind recorder, an Improved METeorological (IMET) recorder, and a stand-alone humidity and temperature recorder. The WHOI moorings also carried vector measuring current meters; temperature recorders; and conductivity and temperature recorders located in the upper 200 meters of the mooring line. The oceanographic instrumentation on the southern WHOI mooring included a chlorophyll absorption meter, a Falmouth Scientific Instruments, Inc., acoustic current meter, and a prototype acoustic doppler current meter developed by Russ Davis and Jeff Sherman at Scripps Institution of Oceanography. The northern WHOI mooring also carried an acoustic rain gauge at a depth of 29 meters on the mooring line. The USF mooring had an IMET system on the surface buoy; and for oceanographic instrumentation, two RD Instruments acoustic doppler current profilers, temperature recorders, and conductivity and temperature recorders. CTD profiles were made at each mooring and at selected locations along 125°W. Figure 4 schematically shows all three moorings and the location of the sub-surface instrumentation.

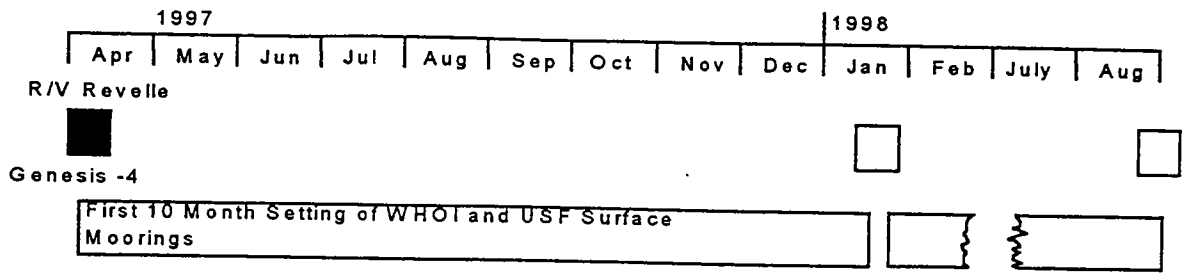

Figure 1: PACS 1 mooring cruise schedule.

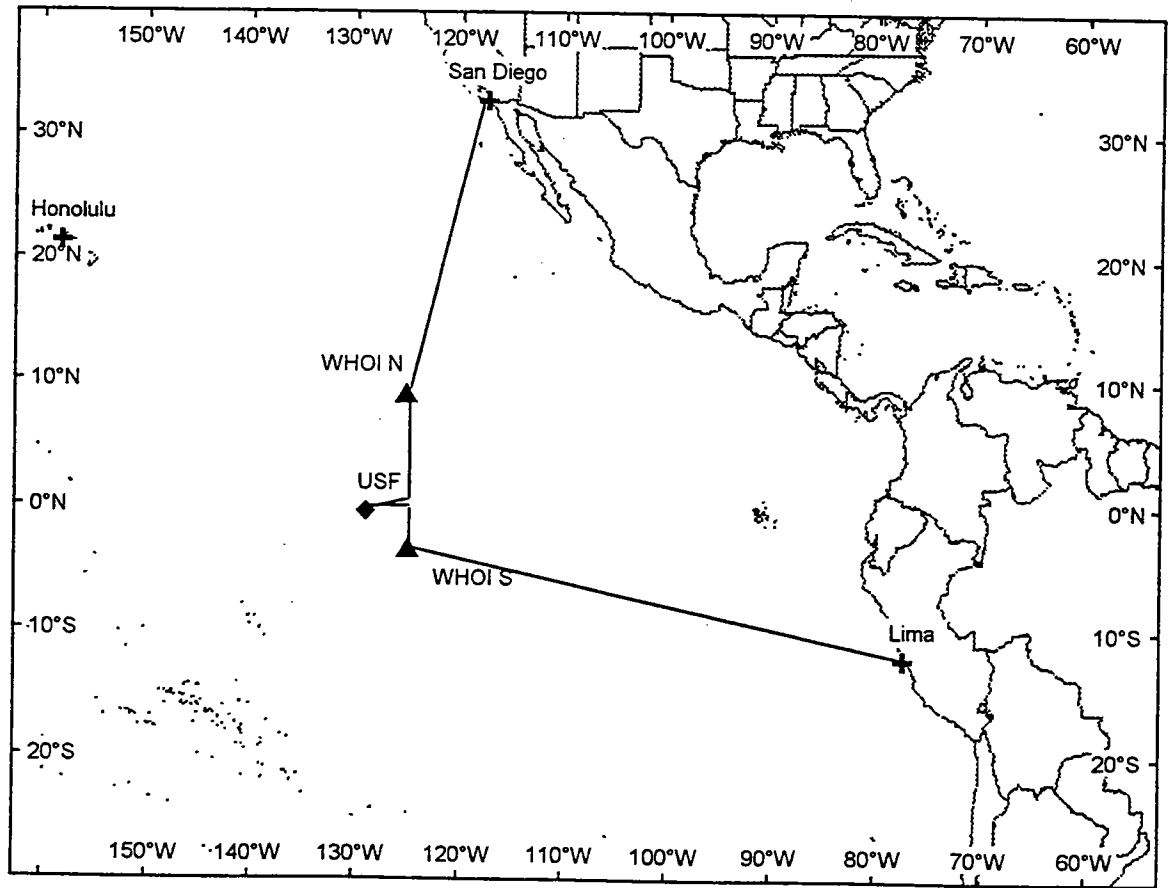
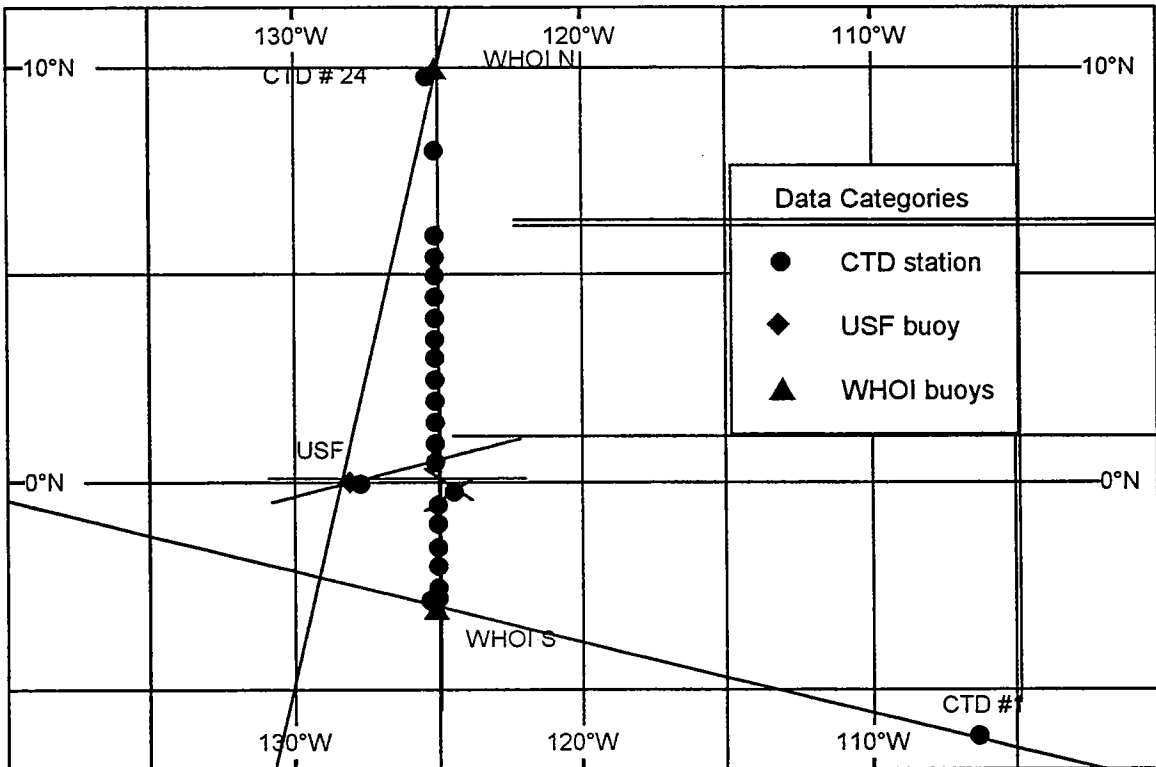

Figure 2: Cruise track and mooring locations.

**Table 1: PACS mooring deployment information**

Mooring	Deployment Date and Time	Anchor Position
WHOI PACS - South Discus Buoy (WHOI Moor. Reference No. 1014)	21 April 1997 @0002 UTC	2°46.78'S 124°39.38'W
USF Toroid Buoy	24 April 1997 @2154 UTC	00°00.39'N 127°58.34'W
WHOI PACS - North Discus Buoy (WHOI Moor. Reference No. 1015)	29 April 1997 @2135 UTC	9°58.99'N 125°23.39'W



**Figure 3: CTD profile locations.**

**Table 2: CTD stations occupied during Genesis 4.**

Note: The time and location are those associated with the start of the CTD profile.

CTD#	Date	Time (UTC)	Latitude	Longitude	Wire Out	File ID
1	4/15/97	1617	5° 57.7 S	106° 11.9' W	1000	PACS060
2	4/19/97	1508	2° 45.0'S	124° 51.6'W	4000	PACS070
3	4/19/97	2016	2° 29.8'S	124° 59.8'W	4000	PACS080
4	4/20/97	0221	2° 46.1'S	124° 39.5' W	4000	PACS090
5	4/22/97	1018	2° 00.0'S	125° 00.0'W	1000	PACS100
6	4/22/97	1404	1° 29.9'S	124° 59.5'W	1000	PACS110
7	4/22/97	1756	1° 00.0'S	125° 00.0'W	1200	PACS120
8	4/22/97	2200	0° 30.0'S	125° 00.0'W	1500	PACS130
9	4/23/97	0400	0° 12.6'S	124° 20.1'W	1000	PACS140
10	4/25/97	1526	0° 00.7'N	127° 35.3'W	4000	PACS150
11	4/26/97	1256	0° 30.1'N	124° 59.7'W	1000	PACS160
12	4/26/97	1630	1° 00.1'N	124° 59.9'W	1000	PACS170
13	4/26/97	1947	1° 30.1'N	124° 59.9'W	1000	PACS180
14	4/26/97	2307	2° 00.0'N	125° 00.0'W	1000	PACS190
15	4/27/97	0235	2° 29.9'N	125° 00.0'W	1000	PACS200
16	4/27/97	0600	2° 59.9'N	124° 59.9'W	1000	PACS210
17	4/27/97	0934	3° 30.0'N	125° 00.0'W	1000	PACS220
18	4/27/97	1302	4° 00.0'N	124° 59.8'W	1000	PACS230
19	4/27/97	1625	4° 30.1'N	124° 59.9'W	1000	PACS240
20	4/27/97	1937	5° 00.0'N	125° 00.0'W	1000	PACS250
21	4/28/97	0015	5° 30.0'N	125° 00.0'W	1000	PACS260
22	4/28/97	0341	6° 0.00'N	125° 00.0'W	1000	PACS270
23	4/28/97	1746	8° 04.7'N	124° 58.2'W	1000	PACS280
24	4/30/97	1531	9° 57.3'N	125° 25.7'W	4000	PACS290

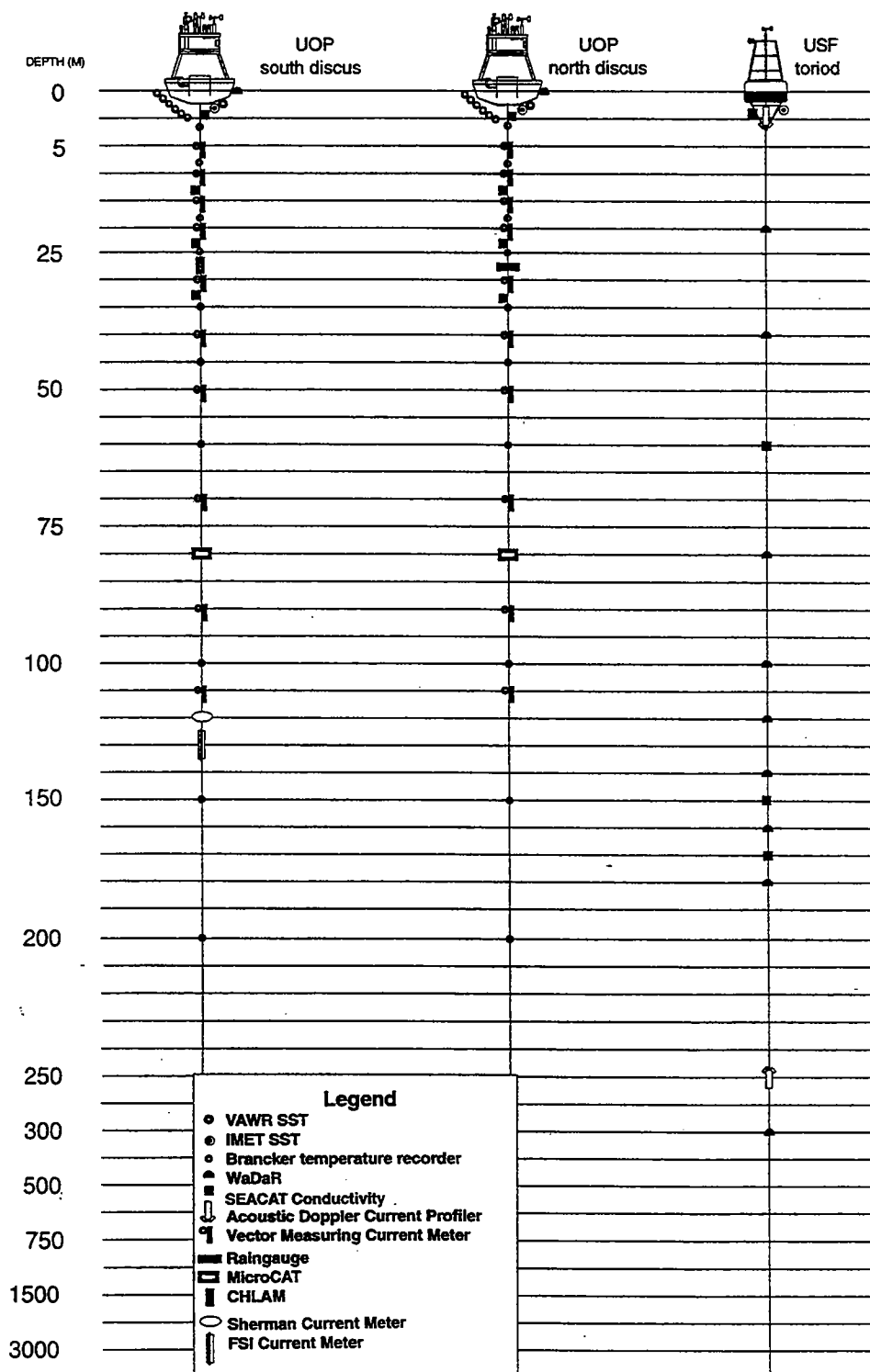

Figure 4: PACS moored array instrument locations.

## A. WHOI Surface Moorings

A total of 38 recording instruments with 74 sensors were deployed on the PACS South surface mooring. There were two meteorological systems, one stand-alone relative humidity/air temperature recorder (SAHTR), ten current meters, seventeen temperature data loggers, five conductivity/temperature-recording instruments, one accelerometer recorder, one chlorophyll absorption meter (CHLAM), and two acoustic current meters.

The PACS North surface mooring had a total of 36 recording instruments with 72 sensors. There were two meteorological systems, one SAHTR, ten current meters, seventeen temperature data loggers, five conductivity/temperature-recording instruments, one tension/acceleration recorder, and one acoustic rain gauge. Each instrument used on the WHOI moorings was given a pre-cruise electronics checkout while at the dock in Callao.

All of the instrumentation used on the WHOI moorings had some type of pre-deployment time mark applied. The Vector Averaging Wind Recorder (VAWR) and Improved METeorological (IMET) recorder had their short-wave radiation sensors black bagged for two record cycles. The VMCMs had their rotors spun. All of the temperature recorders were put in an ice bath for their time intervals. The time marks can be used to verify the accuracy of the instrument's clock in data processing. Appendix 3 has a complete listing of all WHOI instrumentation deployed during Genesis 4. For each instrument type, the listing shows the instrument serial number, the mooring on which it was deployed and the corresponding depth.

The PACS South mooring is shown schematically in Figure 5 and the PACS North mooring is shown in Figure 6. Both WHOI moorings are an inverse catenary design utilizing wire rope, chain, nylon and polypropylene line; and each mooring has a scope of 1.18 (Scope = slack length/water depth). The surface buoy is a three-meter diameter discus buoy with a two-part aluminum tower and rigid bridle.

The two PACS surface moorings are almost identical in design and instrumentation. Fifteen meteorological sensors are mounted on the top half of each buoy tower and are described in the following section. Ten near-surface oceanographic sensors are attached to the bridle and buoy hull. In addition to the buoy-mounted instruments, the South mooring supports an additional 27 recording packages, some of which have multiple sensors; the North mooring supports an additional 25 recording packages.

The design of these surface moorings took into consideration the predicted currents, winds, and sea-state conditions expected during the deployment duration. Further, they were constructed using hardware and designs that had been proven in the recent Arabian Sea deployment.

Shackles used on the WHOI moorings were shot peened to improve their fatigue endurance. Weldless endlinks replaced previously used weldless sling links based on their superior performance in the fatigue tests. Vector measuring current meter (VMCM) cages were gusseted and welds redone to meet new specifications established during Arabian

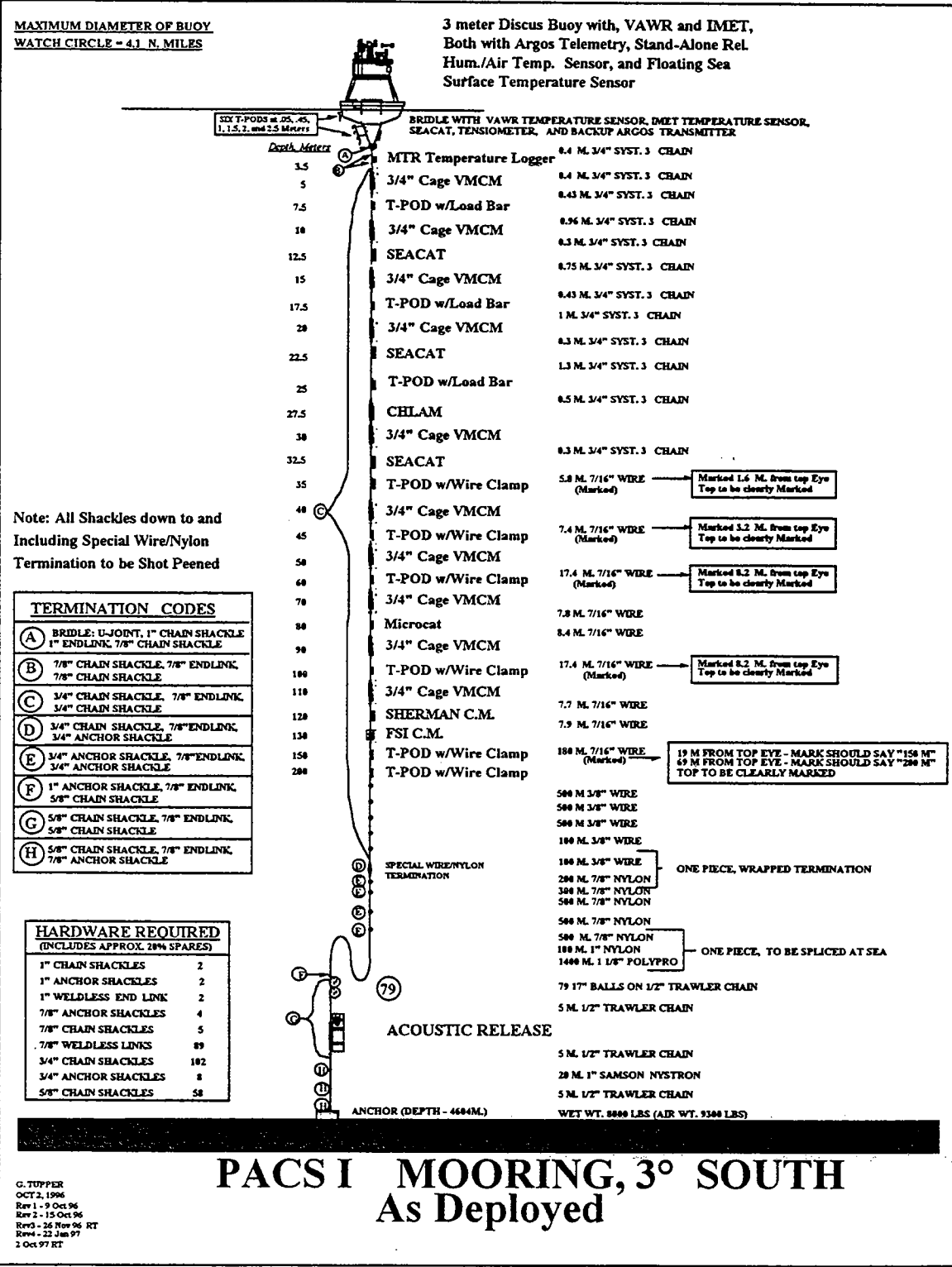
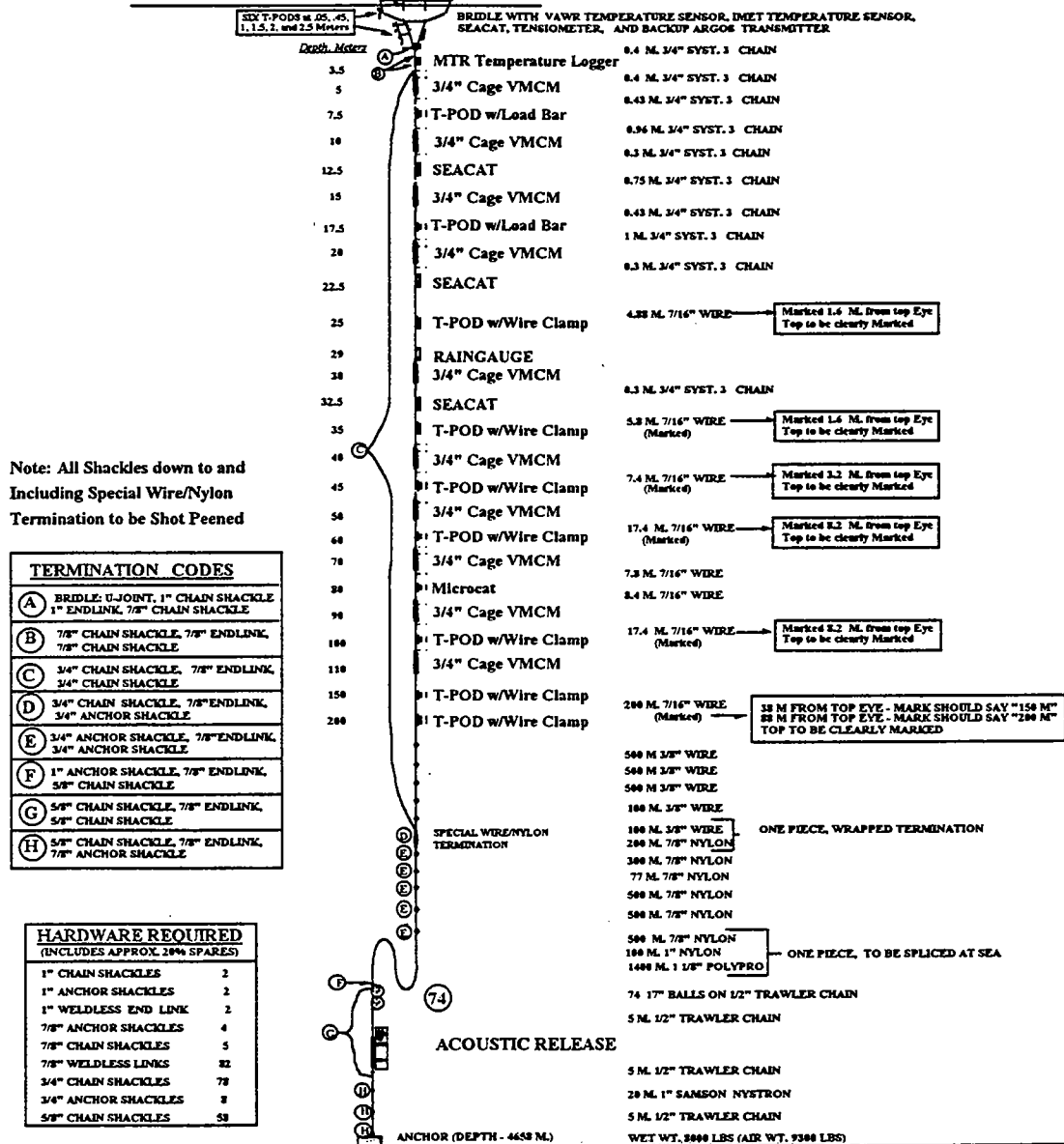

Figure 5: WHOI PACS South mooring schematic.



MAXIMUM DIAMETER OF BUOY  
WATCH CIRCLE - 4.0 N. MILES

3 meter Discus Buoy with, VAWR and IMET,  
Both with Argos Telemetry, Stand-Alone Rel.  
Hum./Air Temp. Sensor, and Floating Sea  
Surface Temperature Sensor



Note: All Shackles down to and  
Including Special Wire/Nylon  
Termination to be Shot Peened

TERMINATION CODES	
(A)	BRIDLE U-JOINT, 1" CHAIN SHACKLE 1" ENDLINK, 7/8" CHAIN SHACKLE
(B)	7/8" CHAIN SHACKLE, 7/8" ENDLINK, 7/8" CHAIN SHACKLE
(C)	3/4" CHAIN SHACKLE, 7/8" ENDLINK, 3/4" CHAIN SHACKLE
(D)	3/4" CHAIN SHACKLE, 7/8" ENDLINK, 3/4" ANCHOR SHACKLE
(E)	3/4" ANCHOR SHACKLE, 7/8" ENDLINK, 3/4" ANCHOR SHACKLE
(F)	1" ANCHOR SHACKLE, 7/8" ENDLINK, 5/8" CHAIN SHACKLE
(G)	5/8" CHAIN SHACKLE, 7/8" ENDLINK, 5/8" CHAIN SHACKLE
(H)	5/8" CHAIN SHACKLE, 7/8" ENDLINK, 7/8" ANCHOR SHACKLE

HARDWARE REQUIRED (INCLUDES APPROX. 20% SPARES)	
1" CHAIN SHACKLES	2
1" ANCHOR SHACKLES	2
1" WELDLESS END LINK	2
7/8" ANCHOR SHACKLES	4
7/8" CHAIN SHACKLES	5
7/8" WELDLESS LINKS	32
3/4" CHAIN SHACKLES	78
3/4" ANCHOR SHACKLES	8
5/8" CHAIN SHACKLES	58

## PACS I MOORING, 10° NORTH As Deployed

G. TUPPER  
OCT 2, 1996  
REV 1 - 9 OCT 96  
REV 3 - 26 Nov 96 RT  
REV 4 - 22 Jan 97  
2 Oct 97 RT  
12 Dec 97

Figure 6: WHOI PACS North mooring schematic.

Sea cyclic fatigue testing. More information about the design effort and cyclic fatigue tests can be found in Trask *et al.*, 1995; and Trask and Weller, 1995.

## 1. WHOI Meteorological Instrumentation

The discus buoys were outfitted with two separate meteorological packages. One system was a VAWR, which logged and telemetered data from eight meteorological sensors. The second meteorological data recording system, IMET, logged data from nine meteorological sensors; this data was also telemetered via Argos. A third instrument made an independent measurement of relative humidity and air temperature and recorded the data internally. Figure 7 shows an aerial view of the meteorological instrumentation mounted on the WHOI discus buoys; Table 3 gives the serial numbers of the sensors and modules of the meteorological instruments. A buoy spin of the South and North buoys was performed at the dock in Callao to confirm that the compasses of each VAWR and IMET were in proper working order. The data from the buoy spins are as follows: Tables 4 and 5, IMET and VAWR compass/vane listings; Figures 8 and 9, buoy spin orientation; Figures 10 and 11, plots of buoy spin data. All three meteorological systems are described in detail below.

### a. Vector Averaging Wind Recorder

One of the two meteorological units mounted on the three-meter discus buoy was a VAWR, which was configured to measure wind speed, wind direction, short-wave radiation, long-wave radiation, relative humidity, barometric pressure, air temperature, and sea surface temperature. Recording on a digital cassette, the VAWR was writing data to tape every 15 minutes. Table 6 shows the type of sensors used for the meteorological measurements and the sampling scheme. Data from the VAWR were telemetered via satellite back to WHOI through Service Argos. The VAWR Argos transmitter had three PTT ID numbers for data transmission, one of which was used for obtaining position information. The standard temperature range typically used in the VAWR is 0° to 30°C. This range was modified to be 0 to 35°C for the PACS experiment due to the expected high temperatures. The VAWR sea-surface temperature (SST) sensor was mounted on the bridle at a depth of approximately one meter. A continuous length of cable was run from the VAWR to the buoy deck and then down to the bridle-mounted SST sensor via an external aluminum pipe mounted on the side of the buoy in order to protect the cable. This method eliminated the need for multiple bulkhead connectors that can affect the temperature reading. Details of the VAWR configuration can be found in Trask *et al.*, 1995.

### b. Improved METeorological System

The IMET system for the PACS discus buoys consisted of nine IMET sensor modules and one Argos transmitter module to telemeter data via satellite back to WHOI through Service Argos. Table 7 details IMET sensor specifications. The modules measure the following parameters:

1. relative humidity with temperature
2. barometric pressure
3. air temperature (R. M. Young passive shield)

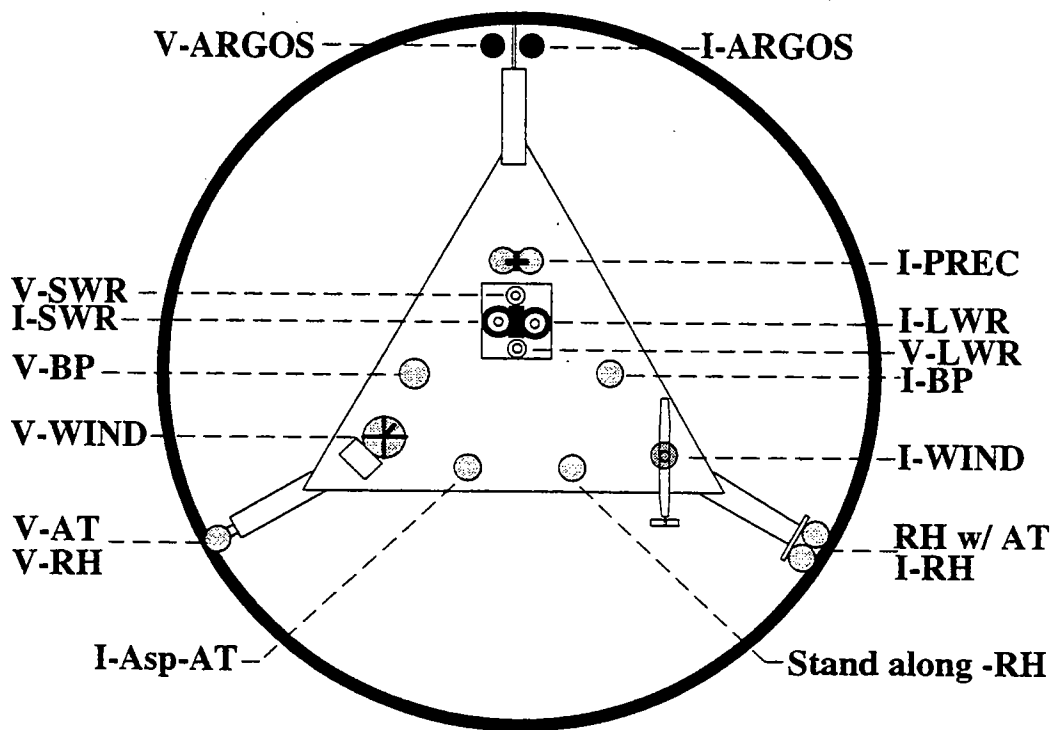

Figure 7: Aerial view of meteorological instrumentation.

**Table 3: Meteorological sensor serial numbers PACS WHOI discus buoys.**

NORTH

IMET

WND	111
SWR	111
LWR	006
HRH	107
BPR	107
SST	109
TMP 01 AT	105
TMP 02 ASP	101
PRC	102
LOGGER	295
PTT	106
ARGOS I.D. #1	27950
ARGOS I.D. #2	27951
ARGOS I.D. #3	27952

VAWR

V722WR	
SWR	26257
LWR	28459
RH	V-028-001
BP	44141
SST	5005
AT	5815
PTT	23978
ARGOS I.D. #1	27919
ARGOS I.D. #2	27920
ARGOS I.D. #3	27921
RESET TIME	1530:00
	5 APR 97

STAND-ALONE

BRH008	
--------	--

SOUTH

IMET

WND	105
SWR	109
LWR	104
HRH	110
BPR	110
SST	005
TMP 01 AT	104
TMP 02 ASP	106
PRC	109
LOGGER	143
PTT	101
ARGOS I.D. #1	27953
ARGOS I.D. #2	27954
ARGOS I.D. #3	27955

VAWR

V707WR	
SWR	28298
LWR	27957
RH	V-028-001
BP	53235
SST	5510
AT	5814
PTT	23974
ARGOS I.D. #1	27916
ARGOS I.D. #2	27917
ARGOS I.D. #3	27918
RESET TIME	1715:00
	2 APR 97

STAND-ALONE

BRH006	
--------	--

**Table 4: South IMET and VAWR compass/vane listings.**

**BUOY SPIN - PACS SOUTH - PERU - 4 APRIL 97**

1.	VAWR CO=5B VANE=62 158 062 DIR=220	IMET CO=158.8 VANE=57.7  DIR=216.5
2.	VAWR CO=49 VANE=41 101 121 DIR=222	IMET CO=101.0 VANE=116.7  DIR=217.7
3.	VAWR CO=74 VANE=1E 037 183 DIR=220	IMET CO=36.9 VANE=179.3  DIR=216.2
4.	VAWR CO=3A VANE=01 340 236 DIR=216	IMET CO=339.2 VANE=236.2  DIR=215.5
5.	VAWR CO=2D VANE=25 278 304 DIR=222	IMET CO=277.0 VANE=298.1  DIR=215.1
6.	VAWR CO=14 VANE=7E 217 003 DIR=220	IMET CO=216.2 VANE=0.7  DIR=216.9

**Table 5: North IMET and VAWR compass/vane listings.**

**BUOY SPIN - PACS NORTH - PERU - 5 APRIL 97**

1.	VAWR CO=52 VANE=63 152 065 DIR=217	IMET CO=162.3 VANE=56.3 DIR=218.6
2.	VAWR CO=15 VANE=7C 214 006 DIR=220	IMET CO=222.2 VANE=355.8 DIR=218.0
3.	VAWR CO=2F VANE=24 270 307 DIR=217	IMET CO=279.6 VANE=297.4 DIR=217.0
4.	VAWR CO=33 VANE=03 335 245 DIR=220	IMET CO=342.2 VANE=234.8 DIR=217.0
5.	VAWR CO=71 VANE=1D 031 188 DIR=219	IMET CO=39.2 VANE=178.6 DIR=217.8
6.	VAWR CO=4E VANE=44 093 127 DIR=220	IMET CO=100.0 VANE=116.7 DIR=216.7

# PACS SOUTH BUOY SPIN

BEARING - 222 DEGREES

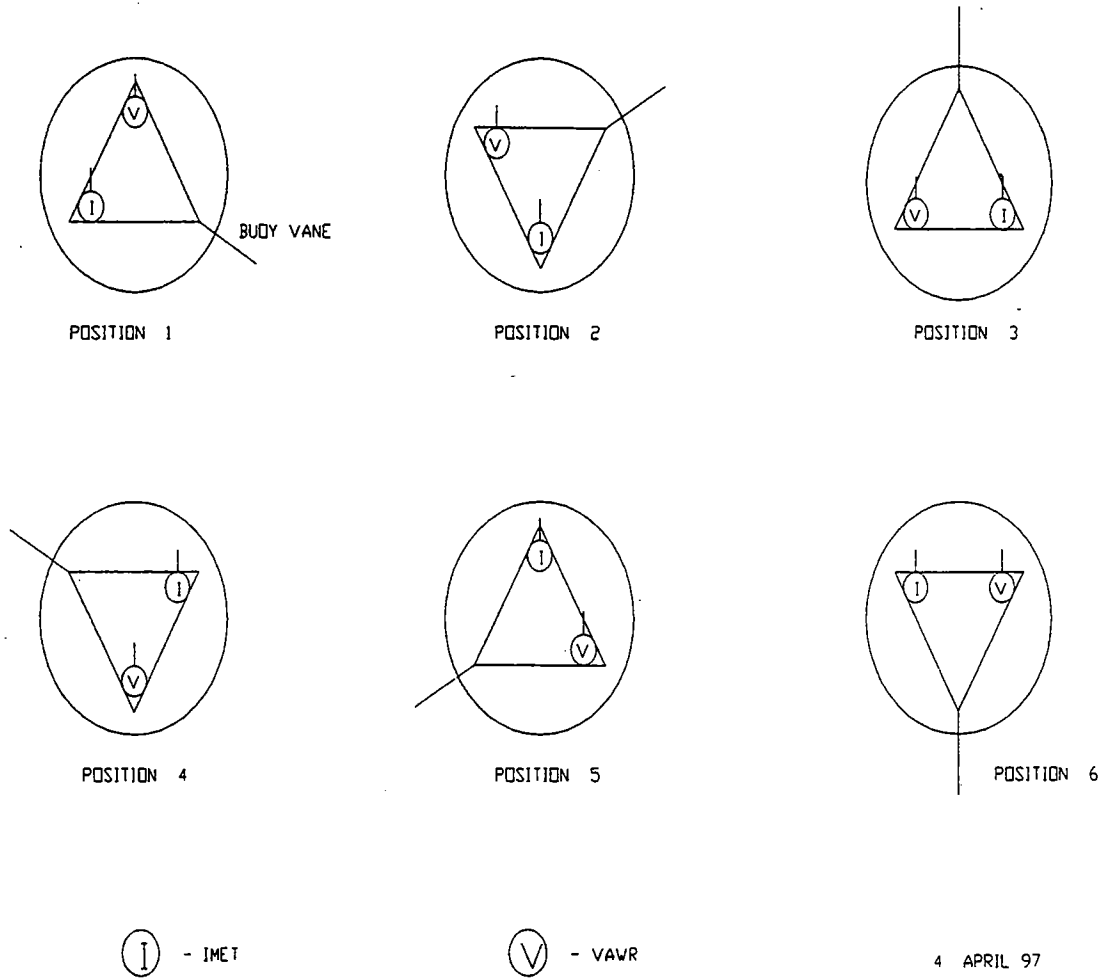

**Figure 8: South buoy spin orientation.**

# PACS NORTH BUOY SPIN

BEARING - 222 DEGREES

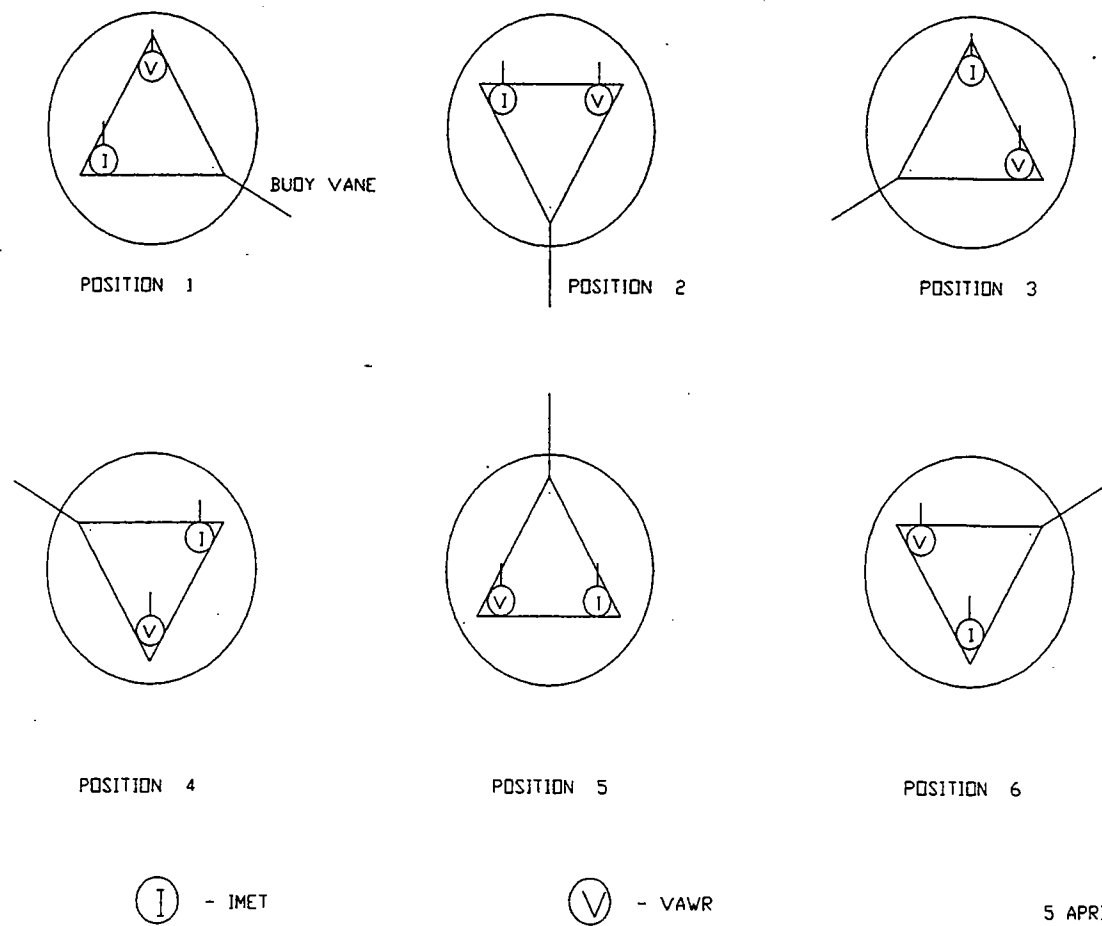

**Figure 9: North buoy spin orientation.**



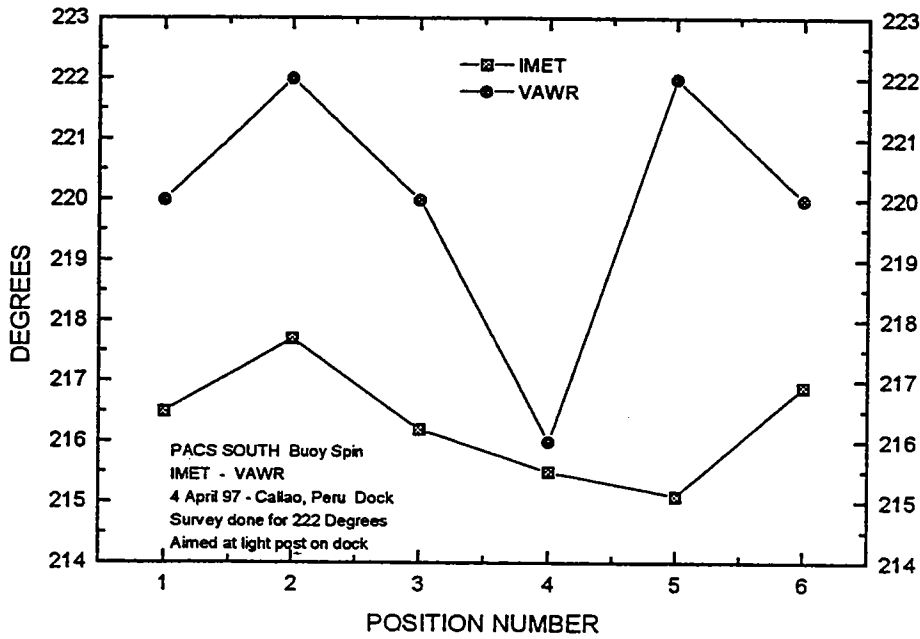

Figure 10: South buoy spin data plot.

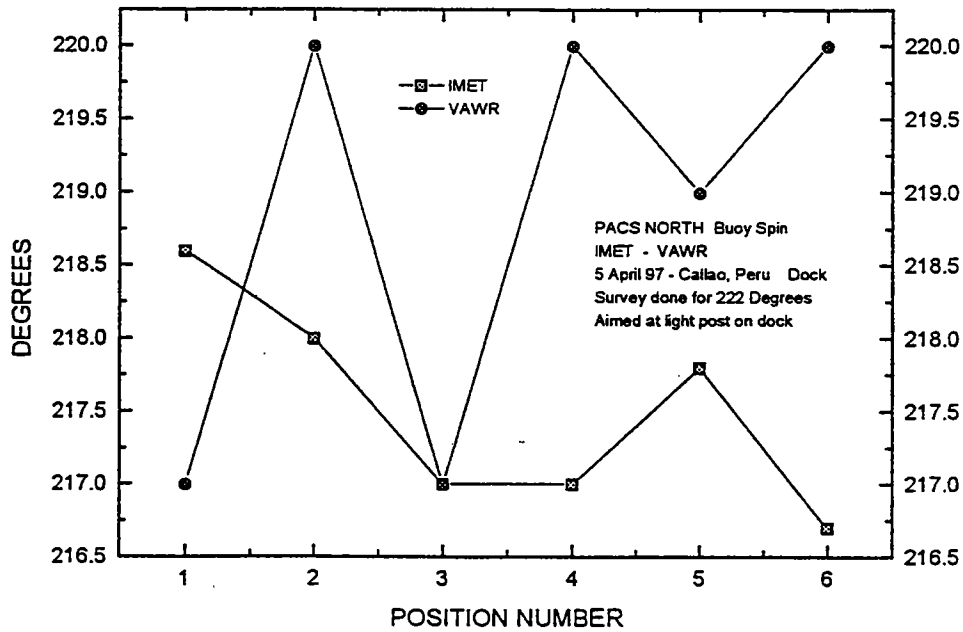

Figure 11: North buoy spin data plot.

**Table 6: VAWR sensor specifications**

<b>Parameter</b>	<b>Sensor Type</b>	<b>Nominal Accuracy</b>	<b>Comments</b>
Wind speed	R.M. Young 3-cup Anemometer	+5% +/-2%	Vector - averaged Note 1
Wind direction	Integral vane w/vane follower WHOI/EG&G	+/- 1 bit 5.6°	Vector- averaged
Insolation	Pyranometer Eppley 8-48	+/-3%	Averaged° of reading
Long-wave radiation Thermopile body Temp. dome Temp.	Pyrgeometer Eppley PIR PIR 10K @ 25° C 10K @ 25°C	+/- 10%	Averaged Note 2 Note 3
Relative humidity	Variable dielectric conductor Vaisala Humicap 0062HM	+/- 2% RH	3.515 sec. Sample Note 4
Barometric pressure	Quartz crystal digiquartz Paroscientific Model 215, 216	+/- 0.2 mbars wind < 20 m/s	2.636 sec. Sample Note 4
Sea temperature	Thermistor Thermometrics 4K @ 25° C	+/- .005 °C	Note 5
Air temperature	Thermistor Yellow Springs #44034 5K @ 25° C	+/- 0.2°C wind > 5 m/s	Note 6

**Notes:**

1. Over estimation of wind speed is characteristic of cup anemometers
2. LWR body temperature is measured during the third quarter of the recording interval, for one quarter of the record time. Error associated with solar heating is not included in accuracy.
3. LWR dome temperature is measured during the fourth quarter of the recording interval, for one quarter of the record time
4. Relative humidity and barometric pressure are burst samples taken in the middle of the recording interval.
5. Sea temperature is measured during the first quarter of the recording interval, for one quarter of the record time.
6. Air temperature is measured during the second quarter of the recording interval, for one quarter of the record time. Error associated with solar heating is not included in accuracy.

**Table 7: IMET sensor specifications**

<b>Parameter</b>	<b>Sensor</b>	<b>Nominal Accuracy</b>
Air temperature	Platinum Resistance Thermometer	+/- .25°C
Sea temperature	Platinum Resistance Thermometer	+/- .005°C
Relative humidity	Rotronic MP-100F	+/- 3%
Barometric pressure	Quartz crystal AIR DB-1A	+/- .5 mbar
Wind speed and wind direction	R.M. Young model 5103 Wind Monitor	-3% (speed) +/- 1.5° (dir)
Short-wave radiation	Temperature Compensated Thermopile Eppley PSP	+/- 3%
Long-wave radiation	Pyrometer Eppley PIR	+/- 10%
Precipitation	R.M. Young Model 50201 Self-siphoning rain gauge	+/- 10%
Aspirated air temperature	Platinum Resistance Thermometer	+/- .25°C

---

The logger polls all IMET modules at one-minute intervals (takes several seconds) and then goes to low-power sleep mode for the rest of the minute. Data are written to disk once per hour. The logger also monitors main battery and aspirated temperature battery voltage.

The air temperature, sea surface temperature, barometric pressure, relative humidity, long-wave radiation and precipitation modules take a sample once per minute and then go to low-power sleep mode for the rest of the minute.

The short-wave radiation module takes a sample every 10 seconds and produces a running, one-minute average of the six most recent samples. It goes to low-power sleep mode between ten-second samples.

The vane on the wind module is sampled at one-second intervals and averaged over 15 seconds. The compass is sampled every 15 seconds and the wind speed is averaged every 15 seconds. East and north current components are computed every 15 seconds

Once a minute, the logger stores east and north components that are an average of the most recent four 15-second averages. In addition average speed from four 15 second averages is stored, along with the maximum and minimum speed during the previous minute, average vane computed from four 15-second averages, and the most recent compass reading.

In addition, an IMET Argos PTT module is set for three IDs and transmits via satellite the most recent six hours of one-hour averages from the IMET modules. At the start of each hour, the previous hour's data are averaged and sent to the PTT, bumping the oldest hour's data out of the data buffer.

4. air temperature (aspirated shield)
5. sea surface temperature
6. precipitation
7. wind speed and direction
8. short-wave radiation
9. long-wave radiation

All IMET modules for the PACS experiment were modified for lower power consumption so that a non-rechargeable alkaline battery pack could be used.

The data logger for the system was based on an Onset Computer Corp. model 7 Tattletale computer with hard drive, also configured and programmed with power conservation in mind. An associated interface board ties the model 7 via individual power and RS-485 communications lines to each of the nine IMET modules, including the PTT module.

### **c. Stand-alone Relative Humidity/Temperature Instrument**

A self-contained relative humidity and air temperature instrument was mounted on the tower of the WHOI discus buoys. This instrument, developed and built by members of the UOP Group, takes a single point measurement of both relative humidity and temperature at a desired record interval. The sensor used was a Rotronics MP-100. The relative humidity and temperature measurements are made inside a protective Gortex shield. The logger is an Onset Computer, Corp., model 4A Tattletale, with expanded memory to 512K. The unit is powered by its own internal battery pack. The instrument interval was set to 3.75 minutes for the PACS Experiment.

The height (and depth) of the buoy and bridle mounted instrumentation can be found in Table 8 for the PACS South buoy and in Table 9 for the PACS North buoy.

## **2. Sub-surface Instrumentation**

The measured water line for the PACS South and North buoys was .33 meters below the buoy deck. Figure 12 illustrates the location of the sub-surface sensors attached to the discus bridle of the PACS South discus and Figure 13 illustrates the PACS North discus.

### **a. Buoy Tension Recorder**

Buoy tension was not measured on the South buoy, instead inside the well was a three-axis accelerometer manufactured by Summit Instruments, model #34103A, which measures X, Y, and Z components. The data were recorded using an Onset Computer, Corp., model 6 Tattletale, with a 40-Mega Byte hard drive attached. Acceleration was sampled every 12 hours beginning at 0000 hours UTC and 1200 hours UTC at a 4 HZ rate for a period of 23 minutes. The data for a two-day period was stored in a temporary buffer where it was then written to the disk drive. The North buoy incorporated the same accelerometer; and included in the measurement was a tension cell placed at the bottom of the three-part bridle. The tension cell, model TH-LB1B-SPL, manufactured by Omega-

**Table 8: PACS South buoy sensor elevations.**

Parameter	Sensor ID	Elevation relative to (meters)		Measurement Location
		buoy deck	water line	
<b>VAWR</b>				
Air temp.	22338	1.77		end of the temp. probe
Relative humidity	V-021-001	2.17		tip of the sensor
Barometric pressure	53235	2.39		center of the vane
Wind speed	707	2.97		axis of cups
Short-wave radiation	28298	3.05		dome shoulder
Long-wave radiation	27957	3.05		dome shoulder
Sea temperature	5510		-1.03	tip of sensor
<b>IMET</b>				
Air temperature	104	1.72		end of temp. probe.
Relative humidity	110	2.31		tip sensor
Barometric pressure	110	2.37		center of the vane
Wind speed	105	2.89		axis of cup
Short-wave radiation	109	3.05		dome shoulder
Long-wave radiation	104	3.05		dome shoulder
Precipitation	109	2.74		edge of the pre- cip. cup
Sea temperature	5		-1.03	tip of sensor
Aspirated Air temp.	106	1.86		end of temp. probe
Stand-alone RH w/ temp.	6	2.41		RH probe
Radar reflector				reflector base to deck
Argos antenna				antenna base to deck
<b>SEACAT</b>	143		-1.38	temperature probe
Temperature recorder	3835		-0.3	thermistor
Temperature recorder	3699		-0.54	thermistor
Temperature recorder	3701		-1.01	thermistor
Temperature recorder	4492		-1.51	thermistor
Temperature recorder	4489		-2.01	thermistor
Temperature recorder	3764		-2.52	thermistor
Tension cell	dummy			bridle spider
WaDaR	274		waterline	

Distance between buoy deck and water line was .33 meters

**Table 9 : PACS North buoy sensor elevations.**

Parameter	Sensor ID	Elevation relative to (meters)		Measurement Location
		buoy deck	water line	
<b>VAWR</b>				
Air temperature	V722WR 5815	2.06		end of the temp. probe
Relative humidity	V-028-001	2.17		tip of the sensor
Barometric pressure	44141	2.38		center of the vane
Wind speed	V722WR	2.97		axis of cups
Short-wave radiation	26257	3.05		dome shoulder
Long-wave radiation	28459	3.05		dome shoulder
Sea temperature	5005		-1.03	tip of sensor
<b>IMET</b>				
Air temperature	105	1.63		end of temp. probe.
Relative humidity	107	2.37		tip sensor
Barometric pressure	107	2.36		center of the vane
Wind speed	111	2.9		axis of cup
Short-wave radiation	111	3.05		dome shoulder
Long-wave radiation	6	3.05		dome shoulder
Precipitation	102	2.73		edge of the pre- cip. cup
Sea temperature	109		-1.03	tip of sensor
Aspirated air temp.	101	1.85		end of temp. probe
Stand-alone RH w/ temp.	BRH008	2.38		RH probe
Radar reflector		1.83		reflector base to deck
Argos antenna		0.51		antenna base to deck
<b>SEACAT</b>				
			-1.53	temperature probe
Temperature recorder	3263		-0.28	
Temperature recorder	4491		-0.51	thermistor
Temperature recorder	4483		-0.99	thermistor
Temperature recorder	3258		-1.49	thermistor
Temperature recorder	3838		-1.99	thermistor
Temperature recorder	3704		-2.49	thermistor
Tension cell			-2.1	bridle spider
WaDaR	275		waterline	

Distance between buoy deck and water line is .33 meters.

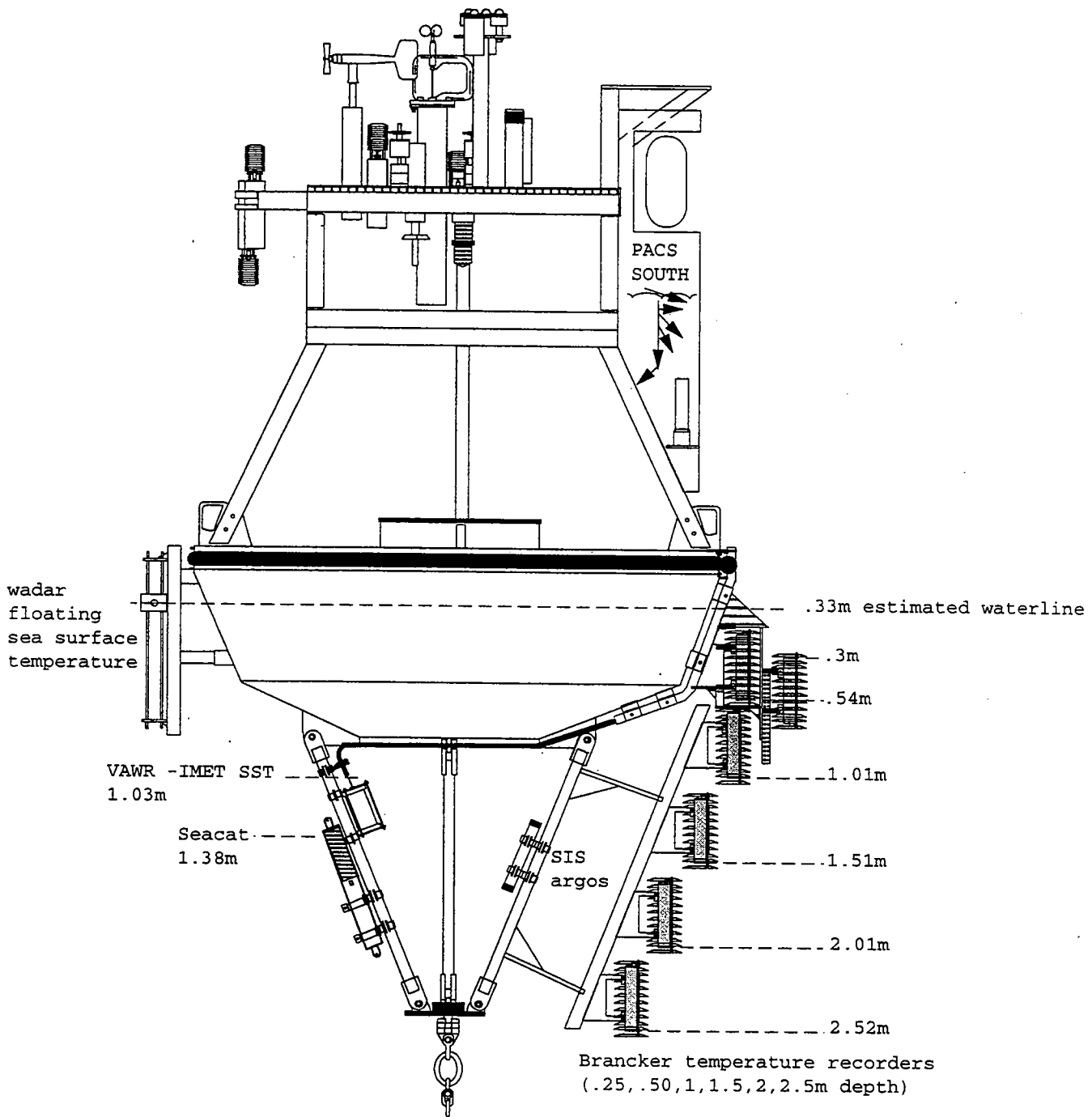

Figure 12: South discus sub-surface profile

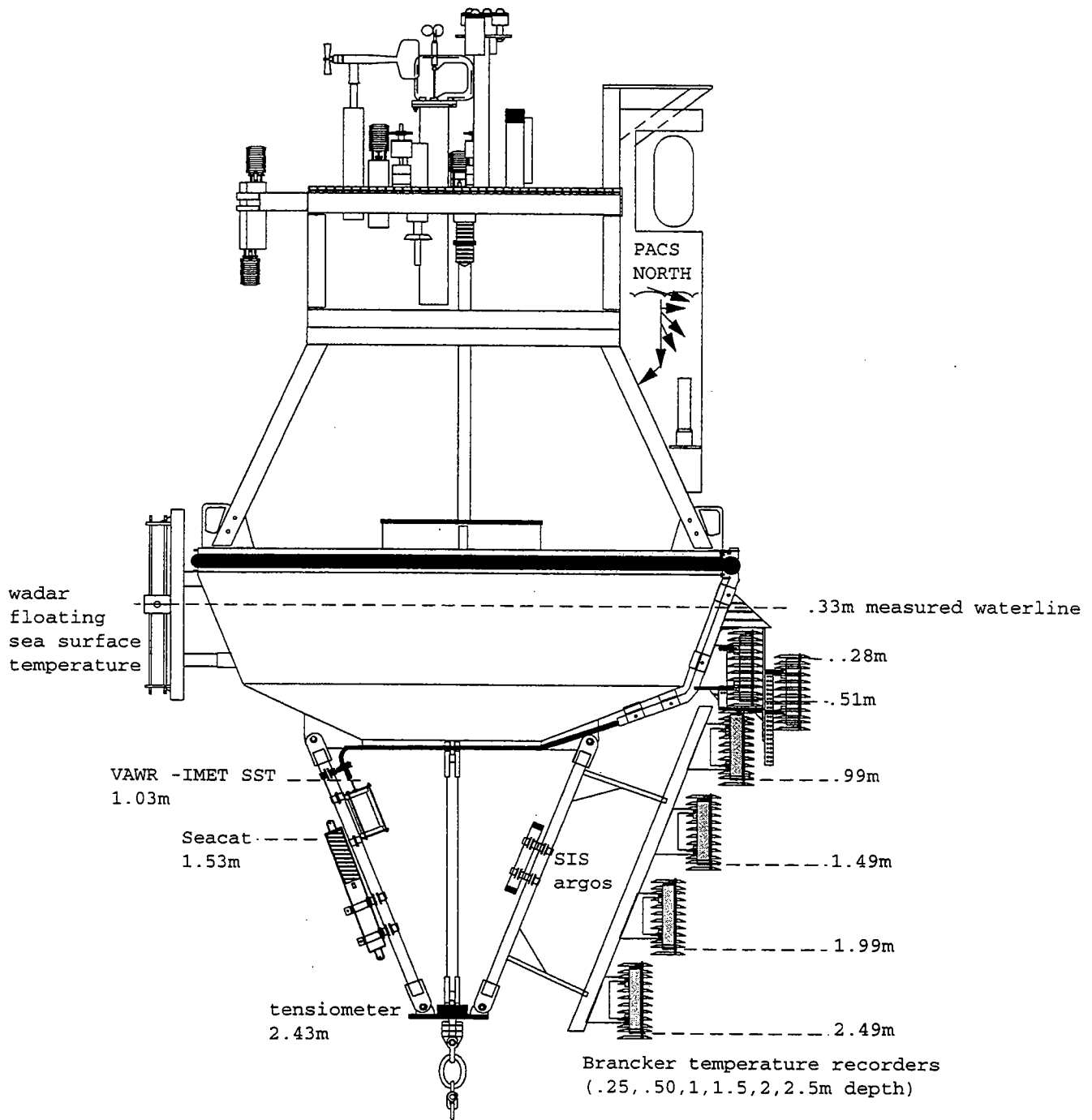

Figure 13: North discus sub-surface profile



dyne, Inc., had a range of 0 to 10,000 pounds. The recorded tension and acceleration data for the North buoy were sampled at a rate of 4 Hz, every 12 hours for 23 minutes beginning at 0000 hours UTC, then at 1200 hours UTC. The data were buffered for two days and then written to disk. A time spike was applied to the tension cell by pulling on the bridle bail with an aircraft strap. Tension was applied at 0000 hours UTC, 23 April 1997; and removed at 0005 hours UTC of the same day.

#### **b. Sub-surface Argos Transmitter**

An NACLS, Inc. Sub-surface Mooring Monitor (SMM) was mounted upside down on the bridle of each discus buoy. This was a backup recovery aid in the event that the mooring parted and the buoy flipped upside down.

#### **c. SEACAT Conductivity and Temperature Recorders**

There were five, Sea-Bird, Inc., SEACAT conductivity and temperature recorders deployed on each of the WHOI surface moorings. The model SBE 16 SEACAT was designed to measure and record temperature and conductivity at high levels of accuracy while deployed in either a fixed or moored application. Powered by internal batteries, a SEACAT is capable of recording data for periods of a year or more. Data are acquired at intervals set by the user. An internal back-up battery supports memory and the real-time clock in the event of failure or exhaustion of the main battery supply. Communication with the SEACAT is over a three-wire RS-232 link. The SEACAT is capable of storing a total of 64,754 samples. A sample rate of 450 seconds was used on the PACS 1 SEACATs. The shallowest SEACAT was mounted directly to the bridle of each of the discus buoys. The others were mounted on in-line tension bars and deployed at various depths throughout the moorings. Shaft anodes were secured to the in-line tension bars in the hope that the anodes would reduce the potential for electrolysis to occur.

#### **d. MicroCAT Conductivity and Temperature Recorder**

The MicroCAT, model SBE37, is a high-accuracy conductivity and temperature recorder with internal battery and memory. It is designed for long-term mooring deployments and includes a standard serial interface to communicate with a PC. Its recorded data are stored in non-volatile FLASH memory. The temperature range is  $-5^{\circ}$  to  $+35^{\circ}\text{C}$ , and the conductivity range is 0 to 6 Siemens/meter. The pressure housing is made of titanium and is rated for 7,000 meters. The conductivity cell is protected from bio-fouling by the placement of anti-foulant cylinders at each end of the conductivity cell tube. The MicroCAT is capable of storing 120,000 samples of temperature, conductivity and time. The sampling interval of the PACS MicroCATs was 225 seconds. Both the PACS North and South buoys had a MicroCAT placed at 80 meters in the mooring string using a titanium load bar with the MicroCAT.

#### **e. Brancker Temperature Recorders**

The Brancker temperature recorders are self-recording, single-point temperature loggers. The operating temperature range for this instrument is  $.2^{\circ}$  to  $34^{\circ}\text{C}$ . It has internal

battery and logging, with the capability of storing 24,000 samples in one deployment. A PC is used to communicate with the Brancker via serial cable for instrument set-up and data download. The PACS 1 Branckers were set to record data every 30 minutes.

A total of 30 Brancker temperature loggers were deployed on the discus moorings, with 15 on each of the buoys. Six were attached to the buoy in a near-surface temperature string, with depths ranging from .25 meters to 2.5 meters. The other nine Branckers on each mooring were dispersed at depths ranging from 7.5 meters to 200 meters.

#### **f. Miniature Temperature Recorder**

A Pacific Marine Environmental Lab (PMEL), Miniature Temperature Recorder (MTR) was mounted at a depth of 3.5 meters in-line on each of the WHOI moorings. The MTR is a single-point temperature logger. System timing and sampling are controlled by an internal microprocessor. It has an internal 9-volt battery that will power the MTR for periods greater than one year. Communication is through a serial cable using a PC. In addition to the system software, the data, as raw counts, are stored in battery-backed RAM. The MTR has the capability of storing 56,800 samples of temperature; the MTRs were set-up for PACS 1 to sample at a 450-second rate.

#### **g. Vector Measuring Current Meters**

The VMCM had two orthogonal cosine response propeller sensors that measured the components of horizontal current velocity parallel to the axles of the two-propeller sensors. The orientation of the instrument relative to magnetic north was determined by a flux gate compass. East and north components of velocity were computed, averaged and then stored on cassette magnetic tape. Temperature was also recorded using a thermistor mounted in a fast response pod, which was mounted on the top end cap of the VMCM. The VMCMs were set to record every 7.50 minutes. A total of twenty VMCMs were deployed on the surface moorings—ten on each mooring—at various depths ranging from 5 meters to 110 meters. All of the VMCMs had a compass spin performed at the dock in Callao to verify that the instrument was not damaged in transport. Appendix 4 provides a description of how each parameter in the VMCM is sampled.

#### **h. WaDaR Temperature Recorder**

The WaDaR temperature recorder used on the PACS buoys was a model TL, manufactured by TSKA, Inc. The WaDaRs are designed to record highly accurate water temperatures over long periods of time. The instrument is self-contained, with batteries, memory and a microprocessor directing operations. Communication is achieved using a PC that provides the WaDaR set-up commands for recording and downloads data from a deployment. The WaDaR has a temperature range of  $-3^{\circ}$  to  $+35^{\circ}$  C. The pressure case is made of titanium and is rated for full-ocean depth. One WaDaR was placed on each of the PACS buoys on a floating, sea-surface temperature device designed by the UOP group; this at-

tached to the buoy hull. The WaDaR will record up to 65,520 temperature measurements in a single deployment. For the PACS experiment the record rate was set to 450 seconds.

**i. Falmouth Scientific Instruments Current Meter**

The 3D ACM, s/n 1428a, is an acoustic current meter on trial deployment from Falmouth Scientific Instruments, Inc. (FSI). The FSI current meter uses four perpendicularly oriented transducers to extract a single-point measurement. In addition to current values of north, east and up, the instrument also records temperature, tilt, direction and time. The instrument was set to record once every 15 minutes, which corresponds to an average measurement of 890 seconds. The remaining 10 seconds were necessary for the instrument to perform the various current calculations and to store them in memory without corrupting the current measurement.

**j. Davis/Sherman Current Meter**

This instrument, developed by Russ Davis and Jeff Sherman at the Scripps Institution of Oceanography (SIO), is an acoustic Doppler current meter. Two orthogonal acoustic sensors point outward in the horizontal plane at the top of the instrument. Each sensor samples the along-beam velocity in a range bin away from the pressure case, thus avoiding eddies and other flow disturbance near the pressure case and supporting cage. The Davis/Sherman current meter was deployed on the PACS South mooring at a depth of 120 meters, between a VMCM at 110 meters and a Falmouth Scientific current meter at 130 meters for the purpose of intercomparison.

**k. Chlorophyll Absorption Meter**

A WET Labs Chlorophyll Absorption Meter (CHLAM), model number 9510005, serial number ACH0126, was placed on the PACS 1 South discus mooring at a depth of 50 meters. The CHLAM was mounted on a frame that fits inside a standard VMCM cage. A SeaBird pump drew water through a mesh filter, the CHLAM, and a brominating canister. Between samples, the bromide diffused through the system to reduce biofouling. Data are stored to a WET Labs MPAK data logger. The CHLAM/MPAK recorded a reference and signal from three optical wavelengths, 650, 676 and 712 nautical miles, and an internal temperature. The sample interval rate is 2 hours. At each sample, the pump is turned on for 10 seconds to flush the system then 10 seconds of sampling with the 10 second average of signal and reference stored in the MPAK. The complete system was powered by two, 10 D-cell alkaline battery packs and should last for approximately 400 days.

**l. Acoustic Rain Gauge**

An acoustic rain gauge from Jeff Nystuen at the Applied Physics Laboratory at the University of Washington was deployed on the PACS North mooring at a depth of 29 meters. This instrument uses a hydrophone and listens to ambient noise. Rain falling on the sea surface produces noise at certain frequencies, and these frequencies are sampled by this instrument. In August 1997, Bob Houze of the University of Washington will stand by the PACS North mooring aboard the R/V *Ron Brown*. The ship will be equipped

with a Doppler radar which will provide rainfall maps. Data from the IMET rain gauges on the surface buoy as well as from the acoustic rain gauge, can be compared with the rainfall data from the Doppler radar.

#### **m. Acoustic Release**

An acoustic release is used just above the anchor to release the mooring from the anchor. It is also used as a transponder to precisely locate the anchor on the bottom.

The type of release used on the two WHOI moorings was an EG&G, model 322.

The PACS 1 South mooring release information is as follows: Release S/N = 339; receiver # = 4; interrogate frequency = 11 KHZ and the reply frequency = 10 KHZ.

For the North mooring the release information is as follows: Release S/N = 323; receiver # = 8; interrogate frequency = 11 KHZ; and the reply frequency = 10 KHZ.

Each release was wire tested to a depth of 1,000 meters prior to deployment.

### **B. USF Surface Mooring and Instrumentation**

To the west of the WHOI moorings at the equator a USF surface mooring utilizing a 7'-6" diameter toroid-shaped buoy for its primary flotation was set. The USF buoy was outfitted with a tower that contained an Improved METeorological (IMET) system which measured wind speed and direction, air temperature, sea surface temperature, short-wave radiation, long-wave radiation, precipitation and barometric pressure. This data was being telemetered via GOES. The subsurface instrumentation on the USF mooring included a downward-looking acoustic doppler current profiler (ADCP) mounted in the buoy bridle. Below the chain was a 225-meter length of faired wire rope which had ten temperature recorders and five conductivity/temperature recorders attached to the wire at various depths. An additional upward-looking ADCP was deployed at a depth of 250 meters.

Twenty-seven different sensors were deployed on the USF mooring. Mounted on the tower of the surface buoy were eight IMET sensors; the Vitel VX4004 data logger, an Argos PTT, the IMET Acoustic Doppler Current Profiler (ADCP) module, a radar reflector; and a light. Subsurface instruments included: a bridle-mounted, downward-looking 600kHz, RD Instruments ADCP; a Sea-Bird Electronics SBE-16 conductivity and temperature recorder (SEACAT) and, the IMET sea surface temperature module. Mounted on the 3/8" wire rope were three SBE-16 SEACATs (temperature and conductivity only) and ten, WaDaR temperature recorders. At the 250-meter break an upward-looking, 150kHz SC-ADCP was attached in line on the mooring along with an SBE-16 SEACAT measuring pressure, temperature and conductivity. Dual EG&G, model 8202, acoustic releases held the mooring to the anchor.

The Ocean Circulation Group of USF deployed a "taught line" air-sea interaction mooring system during PACS 1. The mooring components consisted of 3/8" wire rope;

7/16" wire rope; 1/2" galvanized, long link chain and, 3/4" braided nylon. Mooring attachment hardware included: safety anchor shackles in sizes of 1", 7/8", 3/4", and, 5/8"; and, 3/4" sling links. The mooring was kept in place with a "5-stack", 4000-pound railroad wheel anchor. The mooring had a scope of 0.985. Figure 14 shows the USF mooring schematic and a surface buoy profile.

### C. Shipboard Meteorological System

Following the deployment of a surface buoy and prior to its recovery, it is common practice to position the ship approximately .25 miles downwind of the buoy so that shipboard meteorological observations can be made and compared with the data collected by the buoy. The bow meteorological system was put together to record, from a mast near the bow, accurate values of meteorological parameters for comparison with buoy values. The data are recorded by a Campbell Scientific, CR10, data logger and transmitted to a computer in the main lab where they are plotted on a computer screen and made available for analysis. While close to the buoy the Argos transmissions can be received, decoded, and compared with the shipboard observations. The comparison of data provides a means by which to confirm that the buoy-mounted sensors have not been damaged during deployment. Similarly, if a sensor is damaged during recovery, the sensor may not be able to be recalibrated. If accurate shipboard observations are made prior to recovery these observations provide a means by which to evaluate the sensor's performance at the end of the deployment.

An independent meteorological data recording system was mounted to the jackstaff of the *Revelle* for use during cruise Genesis 4. The package contained wind speed and direction, air temperature, relative humidity, short-wave radiation, long-wave radiation and barometric pressure sensors. The relative humidity/air temperature sensor was a Rotronics MP-100 sensor that is aspirated to minimize the effect of solar heating. The sensor is the same as used in the IMET relative humidity module and the stand-alone relative humidity with temperature instrument. The wind sensor is an R.M. Young propeller anemometer, also used in the IMET wind module. The short-wave sensor is a Precision Spectral Pyranometer (PSP) manufactured by Eppley Laboratory, which is the type used on the IMET system. Long-wave radiation uses Precision Infrared Radiometer (PIR) (Eppley Laboratory), that is also used in the IMET buoy system. Barometric pressure is measured with a Rosemount type 1201. The radiation sensors were mounted on the ship's anchor windless at the bow of the ship.

Attached to the bow rail was an Infrared (IR) thermometer, model #THI-500, manufactured by Tasco. This instrument was aimed downward to the water to make a measurement of the sea-surface temperature. Figure 15 shows the elevation and angle of the bow-mounted IR SST sensor. The data from the IR thermometer were recorded on the bowmast data logger. After each of the PACS 1 mooring deployments, 24 hours of mete-

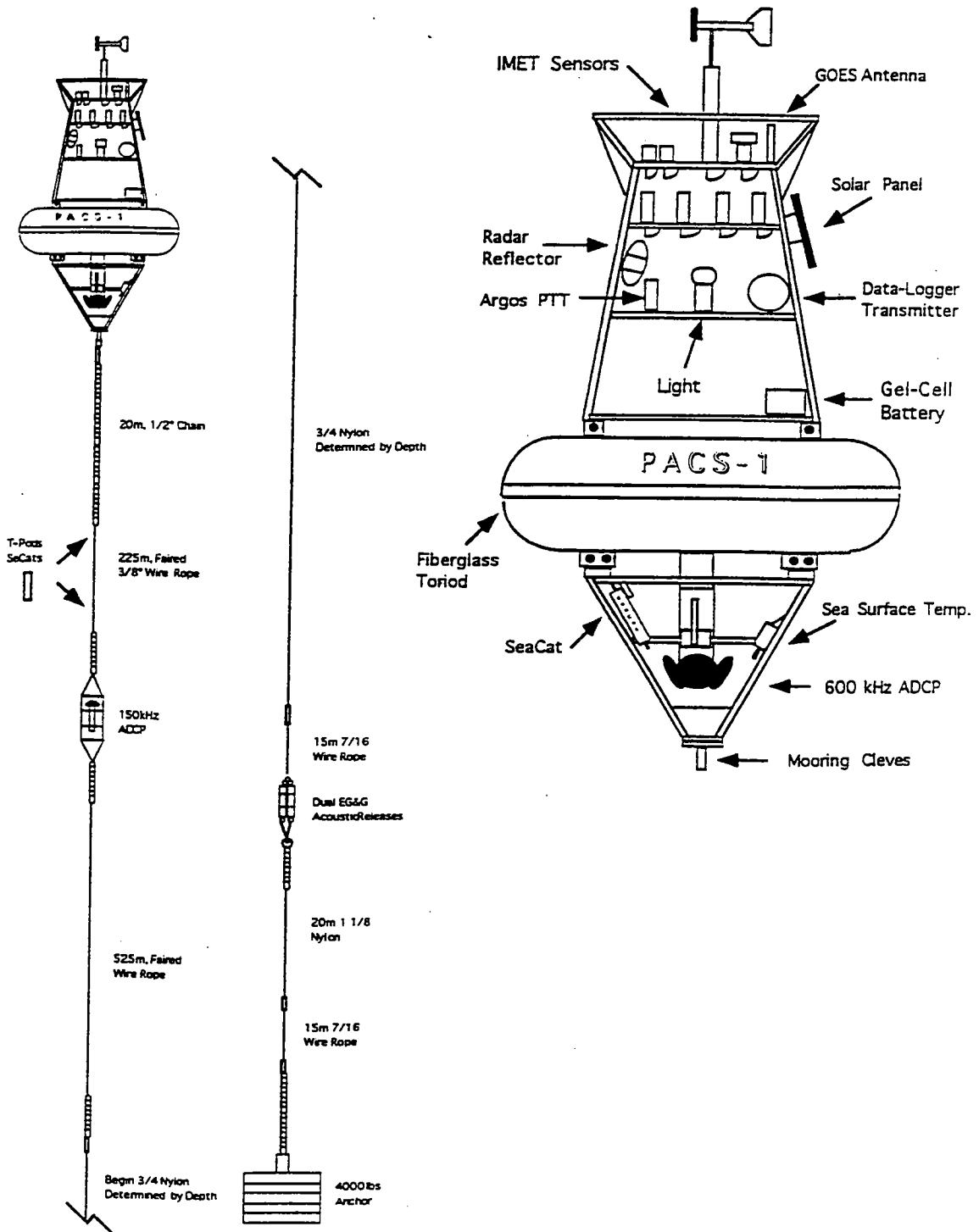

Figure 14 : USF mooring schematic and buoy profile

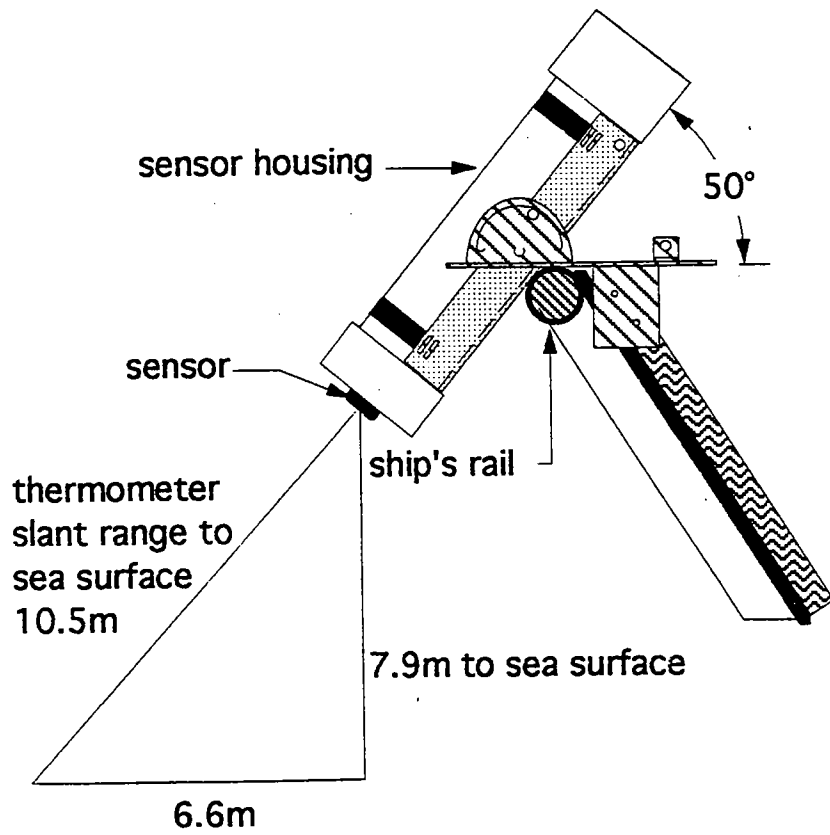

Figure 15: Bow-mounted IR SST elevation.

orological observations were made using the WHOI bowmast-mounted meteorological sensors and the use of hand-held meteorological sensors. These sensors included an AIR Model #AIR-HB-1A, which measured barometric pressure. Another Tasco IR thermometer was used for sea-surface temperature, and a mercury thermometer was also used to measure the sea-surface temperature by dropping it with a bucket to the surface. A Vaisala relative humidity/air temperature sensor, model #HM34, was used to take readings at the bow of the ship. The hand-held data were taken every 15 minutes during the 24-hour period; the bowmast-mounted meteorological system was on and logging data for the entire cruise period.

### **Section 3: Cruise Chronology**

The buoys, meteorological and oceanographic equipment, and related gear were shipped to the port of Callao, Peru. Preparations were done in a shed on the docks beginning in late March. The buoy meteorological instrumentation and telemetry of the meteorological data were checked out, and all VMCMs, Brancker temperature recorders (TPODS), (SEACATs, and other instruments were prepared. On April 5, 1997, the *Revelle* arrived from its previous leg. Loading of the equipment began on April 6 and continued through the next day until it was halted by Peruvian Customs officials. Loading resumed late on April 8, and gear was aboard early on the April 9. Delayed by local authorities past the scheduled departure time of 1600 hours, the ship finally departed Callao at 1930 hours local.

From Callao, the ship steamed west-northwest toward the first mooring location at 3°S, 125°W. The course to that point was altered to accommodate a request by Dr. Peter Lonsdale, SIO, to collect Sea Beam data near the Galapagos Rise. On April 15 at 0900 hours local, the ship stopped to lower two acoustic releases for testing and take a CTD profile using the WHOI self-contained Sea-Bird SBE-19. At 1100 hours local, the ship resumed steaming towards the site of the first mooring. While underway to the site, preparations were carried out for the mooring deployments. These included familiarization of the science party with the operation of the Lebus winch and spooler, with the handling of lines, and with the basic safety issues.

#### *WHOI PACS South surface mooring*

The *Revelle* arrived at the site of the first mooring, 3°S, 125°W, early on April 19, 1997. A plot of the bottom topography made by Jeff Donovan and Kam Sahami using a new bottom topography data set developed at SIO, provided a more detailed preview of the region than available from GEBCO charts. Using this data, several probable sites were identified, and an overnight bottom survey using Sea Beam was carried out. In the morning, a 4,000-meter deep CTD was attempted at the site. This was unsuccessful due to the CTD writing many short files once it got deeper than 2,000 meters. Upon recovery, it was discovered that the sliding on-off switch was loose, and that this caused the CTD to turn on and off. Before each future cast, the two screws that mount the switch



were tightened with a screwdriver. While the CTD was being checked out, the ship moved north to the site of the next planned CTD. A successful 4,000 meter CTD was obtained at 2.5°S, 125°W; and another when the *Revelle* returned to the mooring site.

On the night of April 19 and early on the 20<sup>th</sup>, the bottom was resurveyed, and the surface currents were evaluated using the ship to judge surface set and drift. An area that was flat (within one 10 m contour) was found roughly between 2°45'S and 2°47'S 124°38'W and 124°40'W. Figure 16 shows the bottom contours developed from the Sea Beam surveys. The currents were from the south-southwest (approx. 205°), so an approach path for the mooring deployment was chosen, with the ship steaming toward 205. A start point (2°40.3'N, 124°36.2'W) was chosen roughly seven nautical miles from the target (2°46.6'S, 124°39.2'W) with an anchor drop point chosen 470 meters (10% of the water depth) further along the same track. The Sea Beam, with sound speed correction based on a daily 1500-meter XBT and transducer depth accounted for, gave a depth at the target site of 4605 meters. The 3.5 kHz depth sounder, with transducer depth correction, read 4623 meters that, with a Matthews table correction of 8 meters, gave 4631 meters. Because the mooring was designed for 4600 meters, no further adjustments were made to its length.

The deployment began at 0630 hours local on April 20 and lasted until 1700 hours local. Delays occurred due to a heat-related loss of power on the Lebus winch; and a shut down of the winch to investigate a strong smell of burning electrical insulation. However, the Lebus restarted after it cooled, and no source of the burning smell was located. The anchor was dropped at 1702 hours local (000 UTC) on April 21, 1997 at 2° 46.955 S, 124° 39.412 W. Following the anchor drop, an acoustic survey of the anchor position was carried out (Figure 17), and the anchor location was identified as 2°46.785'S, 124°39.385'W, approximately 6.9% of the water depth away from the anchor drop site. The average sound speed used for the survey 1507.4 m s<sup>-1</sup> was obtained from the sound speed profile being used by the Sea Beam, which, in turn, is based on a daily XBT down to 1500 meters and climatological conditions at greater depths. Alongside the buoy (2°45.728'S, 124°38.692'W), Sea Beam gave a water depth of 4618.7 meters, and the Bathy 2000 3.5 kHz system gave 4602 meters (with Matthews table correction of 8 meters).

After the anchor survey, the ship was positioned roughly a quarters of a mile downwind for a 24-hour comparison of ship and buoy meteorological sensors. On April 21 the small boat was used to make a visual inspection of the buoy and to note the water-line and position of the floating SST sensor.

### *CTDs along 125°W*

After leaving the site of the PACS South surface mooring, the *Revelle* steamed north along 125°W, making CTD profiles to 1,000 meters every 0.5° of latitude up to the equator. The position of the CTDs made during the cruise are shown in Figure 3 and more detail, including positions and plots of the temperature, salinity, and density profiles are given in Appendix 2. Upon reaching the equator, *Revelle* steamed west to 128°W, the

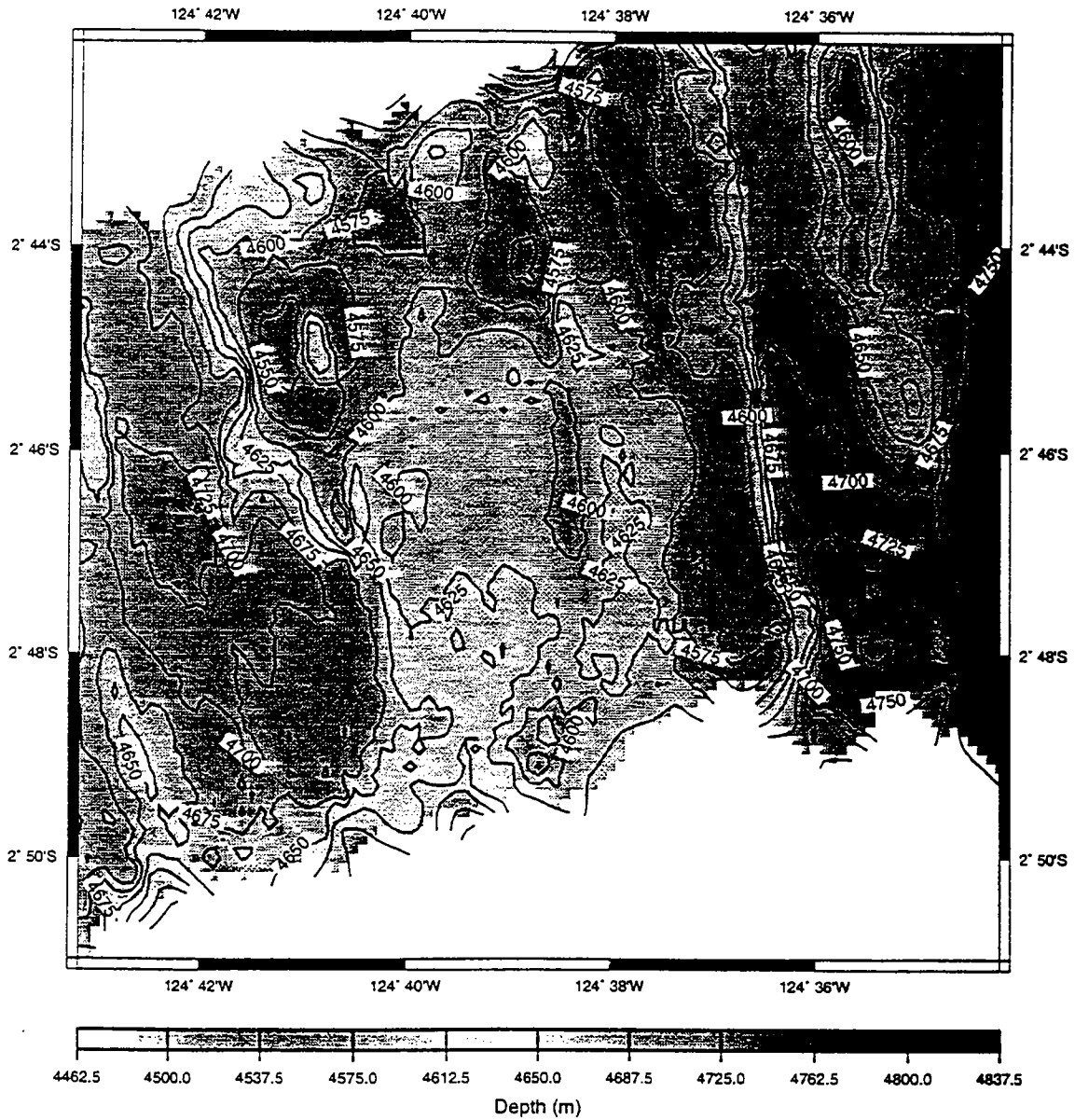

Figure 16: PACS South survey bathymetry grid.

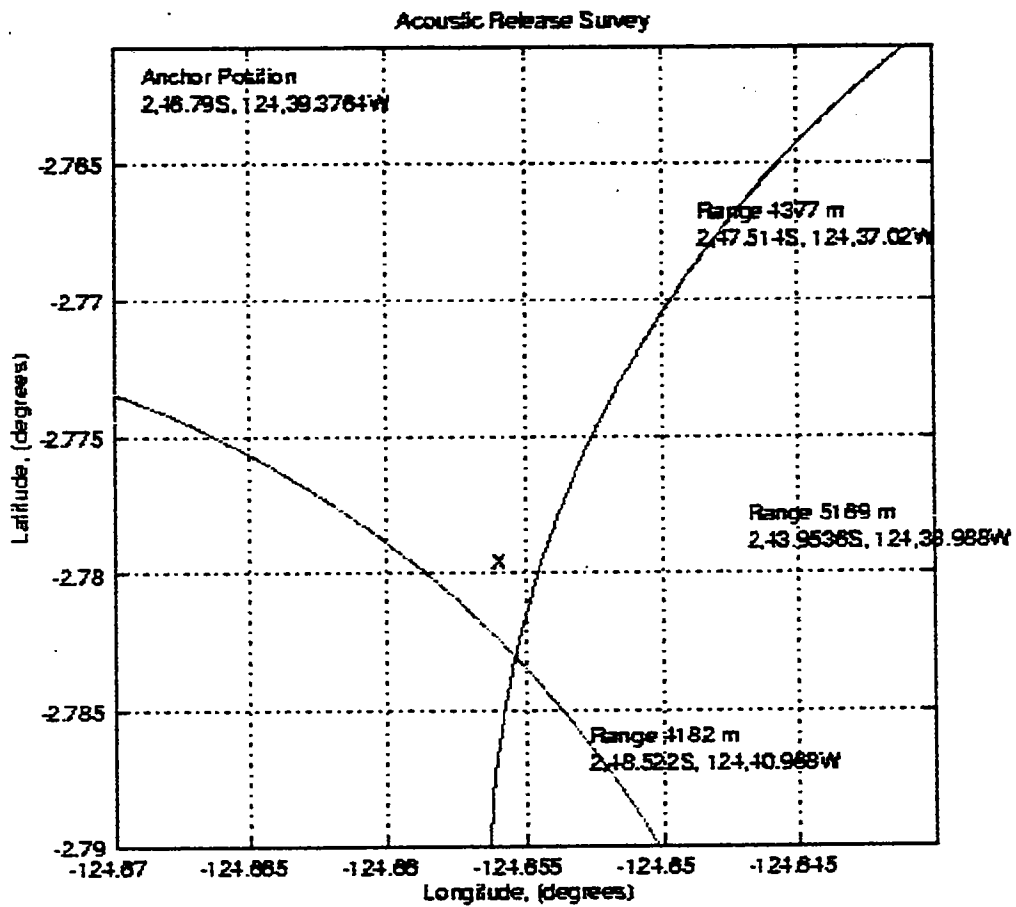

Figure 17: PACS South anchor position survey.

site of the USF mooring. While steaming west, a strong (2 knots) eastward surface current was encountered.

#### *University of South Florida surface mooring*

On April 23 a bottom survey was conducted of the site. Based on the digital bathymetric data brought along by Jeff Donovan, a target region was identified just north of the equator centered at about  $0^{\circ}12'N$ ,  $128^{\circ}10'W$ . The ship's ADCP was jury-rigged (the differential GPS had been sent out for repair) to provide an indication of the currents; and it was learned that the equatorial undercurrent had surfaced. Surface currents were  $100\text{-}120\text{ cm s}^{-1}$  to the east; and the core of the undercurrent at a depth of 75 meters had speeds of approximately  $200\text{ cm s}^{-1}$ . The ship was positioned 2.8 miles east of the target and steamed slowly to the west against the current while deploying the mooring. The mooring deployment began at 0900 hours local, and the anchor was dropped at 1454 hours local. The mooring position was determined by bringing the *Revelle* near the buoy; it was recorded as  $0^{\circ}00.396'N$ ,  $127^{\circ}58.346'W$ .

The small boat was used to make a visual inspection of the buoy. Following the deployment, a 24-hour period of comparison of ship and buoy meteorological data was carried out. The ship departed the site at 1700 local on April 25.

#### *CTDs along $125^{\circ}W$*

After leaving the site of the USF surface mooring, *Revelle* steamed toward  $0.5^{\circ}N$ ,  $125^{\circ}W$  and resumed making 1,000 meters CTD profiles every  $0.5^{\circ}$  latitude along  $125^{\circ}W$ . CTD stations were occupied at  $0.5^{\circ}$  through  $6.0^{\circ}N$  without problem. At  $6.5^{\circ}N$ , the CTD failed to record data. The *Revelle* continued north while the CTD was worked on. The problem was the magnetic reed switch used as an on-off switch was no longer turning on. A stronger magnet was jury-rigged in its place.

#### *Repair to PMEL Buoy*

On April 28, 1997, at the request of Hugh Milburn, the ship stopped to carry out a repair on the Next Gen surface mooring recently deployed at  $8^{\circ}N$ ,  $125^{\circ}W$ . The small boat was put over the side, and Rick Cole and Ben Webster went on board the buoy, unplugged the Eppley short-wave sensor from the data logger and protected the plug and cable from exposure to the elements. Following this repair, *Revelle* moved off and made a 1,000-meter CTD. Then she steamed toward  $10^{\circ}N$ ,  $125^{\circ}W$ .

#### *WHOI PACS North surface mooring*

On the night of April 28, 1997, a bottom survey was initiated in the vicinity of  $10^{\circ}N$ ,  $125^{\circ}W$ , using the Sea Beam and 3.5 kHz systems. The bathymetry proved to be dominated by north-south running ridges (Figure 18), and it was difficult to identify an

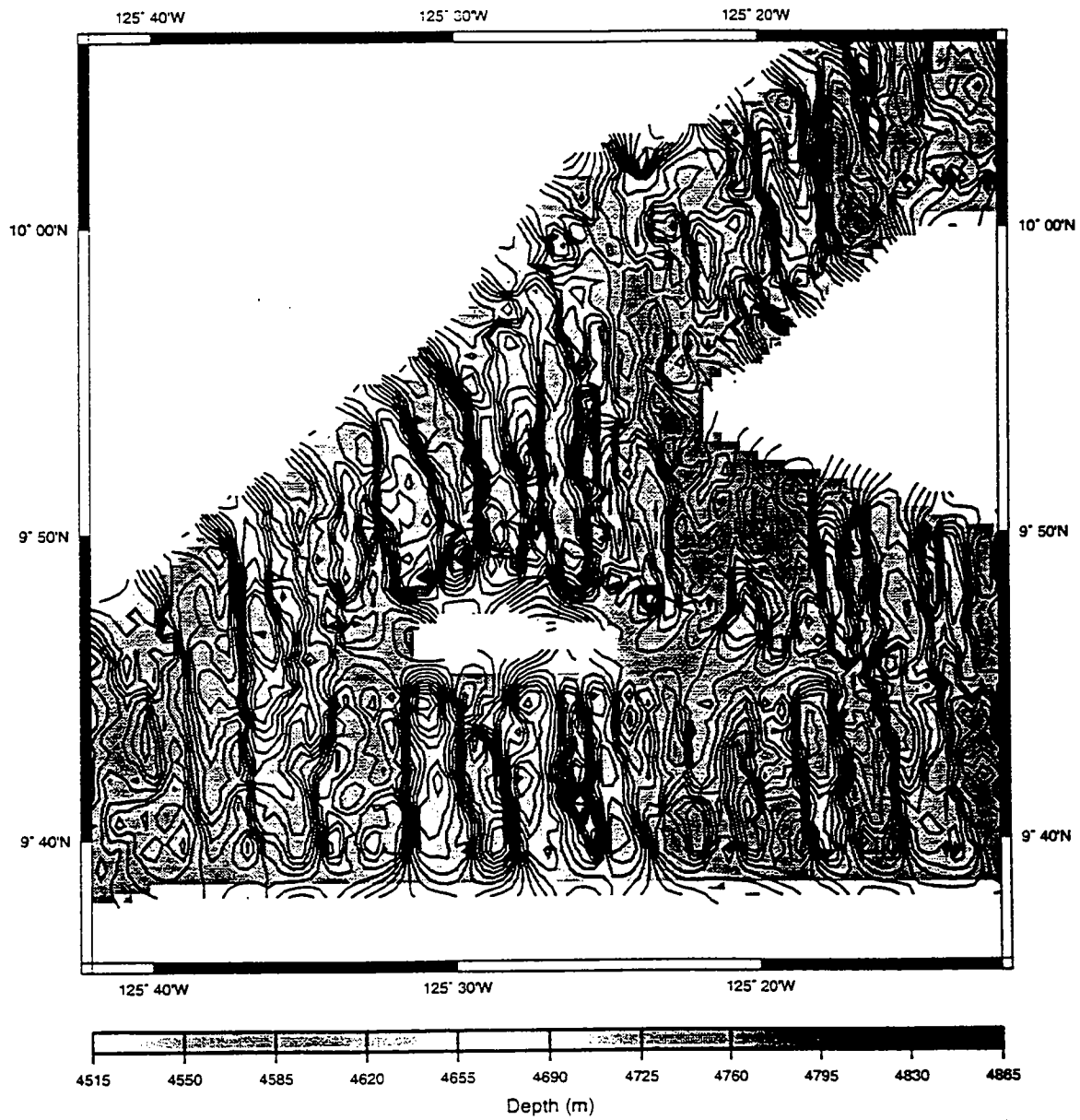

Figure 18: PACS North survey bathymetry grid.

obvious target. The ADCP showed 0.5 knot to 1.0-knot surface currents in the upper 50 meters that changed direction over the course of the night. Squalls of over 20 knots with rain came and went. Early on April 29, the decision was made to use a course of 040°, steaming into the swell out of the northeast and against what was, at that time, surface flow out of the east.

A region of topography that varied slowly between depths of 4600 meters to 4700 meters was identified that offered a run of approximately 10 nautical miles when taking an 040° heading starting in the southwest. The strategy chosen was to adjust the mooring for a depth of 4650 meters and try to drop anchor shortly after the ship steamed over the bottom close to that depth. To make the adjustment, 150 meters times the 1.18 scope, or 177 meters of nylon were added. This was done by using a 500-meter reel of nylon in place of a 400-meter reel and adding a new 77-meter shot.

An initial point for the mooring deployment was chosen as 9°52.3'N, 125°28.7'W. A nominal target of 9°57.7'N, 125°24.3'W was chosen at a range of 6.5 nautical miles, with another way point 9.9 miles away at 10°0.3'N, 125°22.0'W was given to the bridge. At PACS South, the automatic navigation system had gone into reverse as the ship steamed over the anchor point. To prevent this, the navigation system was set up to steam to the point 9.9 nautical miles away.

The mooring deployment started at 0800 hours local (1500 hours UTC). When the buoy was over the side and just behind the stern, the ship would back down when the autopilot was engaged. Therefore, the deployment was done with manual steering. At 1435 hours local (2135 hours UTC) the anchor was dropped at 9°59.082'N, 125°23.245'W, approximately 8.7 nautical miles along the track. An inspection in the small boat was done after the mooring settled out, with an attempt to videotape the action of the floating SST sensor and to note the waterline (14" below the deck). The buoy looked fine, with the Brankers riding at design depth. An anchor survey (Figure 19) located the anchor at 9°58.995'N, 125°23.388'W. The average sound speed of 1503.7 m s<sup>-1</sup> was obtained from the XBT and climatology-based sound-speed profile being used with the Sea Beam. The fall back was 303.9 meters or 6.5%. By the Sea Beam, the water depth at the anchor was 4664 meters.

Following the anchor survey, the ship moved to a quarter of a mile downwind and hand-held meteorological observations began every 15 minutes. These continued until 0800 hours on April 30, when the ship moved off 1.5 nautical miles and a 4,000-meter CTD profile was taken. Following the CTD, the ship moved back to take station a quarter of a mile downwind of the buoy. The bow-mast and telemetered buoy data compared well, and a fax from WHOI indicated that the Argos telemetry was successfully being received there.

At 1430 hours on April 30, 1997, *Revelle* had been on station for 24 hours following the deployment of the PACS North surface mooring and the ship left to begin the passage back to San Diego. The ship was unloaded on May 5 and 6, 1997 and the gear shipped back to WHOI.

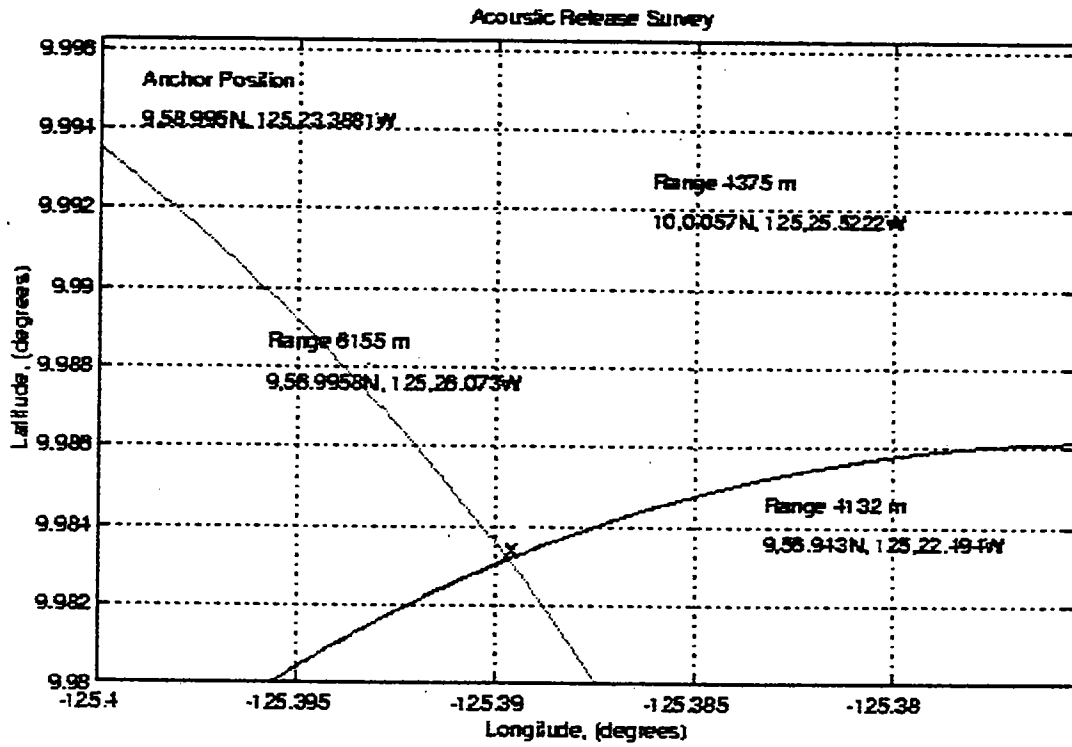

Figure 19: PACS North anchor position survey

## Acknowledgments

The captain and crew of the R/V *Roger Revelle*, and the Resident Marine Technician, Bob Wilson, and Computer Technician, Todd Porteous, deserve special thanks for their hard work and dedication in making Genesis 4 a total success. A ship is a good ship, only when there are highly skilled professionals to run her. Also we sincerely thank Nancy Brink and Penny Foster for their help in preparing this report.

This work was supported by the National Oceanic and Atmospheric Administration Grant No. NA-66GP0130.

## References

- Trask, Richard P., Bryan S. Way, William M. Ostrom, Geoffrey P. Allsup, and Robert A. Weller, 1995. Arabian Sea Mixed Layer Dynamics Experiment, Mooring Deployment Cruise Report, R/V *Thomas Thompson* Cruise Number 40, 11 October-25 October 1994. Upper Ocean Processes Group, UOP Technical Report 95-1, Woods Hole Oceanographic Institution Technical Report WHOI-95-01, 64 pages
- Heinmiller, Robert H., 1976. Mooring Operations Techniques of the Buoy Project at the Woods Hole Oceanographic Institution. Woods Hole Oceanographic Institution Technical Report, WHOI-76-69, 94 pp.
- Trask, Richard P., and Robert A. Weller, 1995. Cyclic Fatigue Testing of Surface Mooring Hardware for the Arabian Sea Mixed Layer Dynamics Experiment. Upper Ocean Processes Group, UOP Technical Report 95-15, Woods Hole Oceanographic Institution Technical Report, WHOI-95-16, 66 pp.



## **Appendix 1 Cruise Participants**

### **WHOI**

Robert Weller, Chief Scientist  
Will Ostrom  
Bryan Way  
Jon Ware

### **USF**

Rick Cole  
Jeff Donovan  
Jyotika Virmani  
Bob Helber

### **University of Colorado**

Kamran Sahami  
Johannes Loschnigg

### **NCAR**

Ben Webster

### **Volunteers**

Roger Archibald  
Stephanie Ocko

### **Peruvian observers:**

Luis Beltran  
Jorge Paez  
Eddy Rojas

### **SIO**

Bob Wilson, resident technician  
Todd Porteous, computer technician

## **Appendix 2**

### **CTD temperature, salinity and density profiles**

Figure A2-1 is a composite plot of CTD data, containing three sections showing salinity, potential temperature and potential density.

Figures A2-2 through A2-13 are profiles from each CTD station showing potential temperature, salinity, and sigma-t.

Pacs 1 125 W CTD Section: Salinity

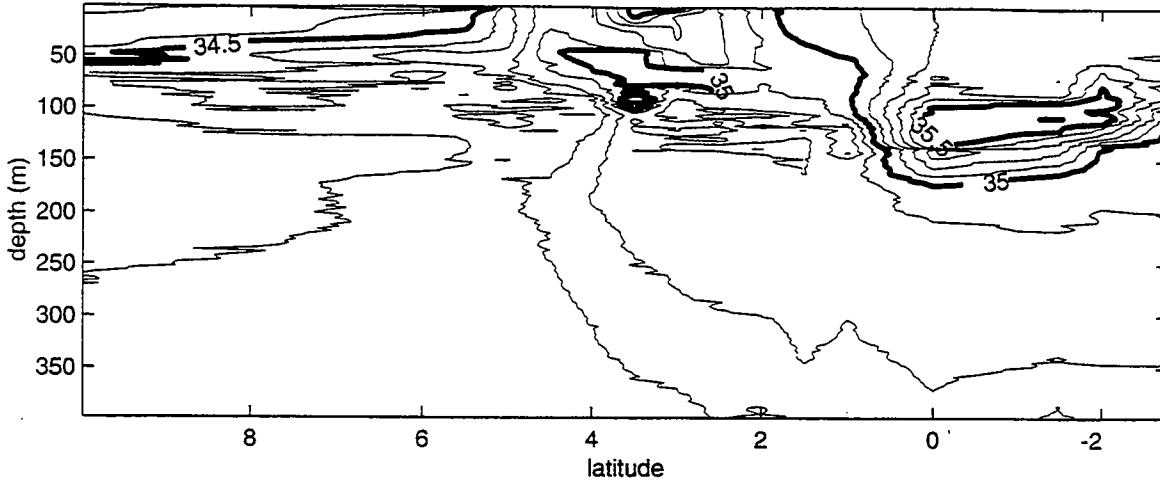

Pacs 1 CTD Section: Potential Temperature

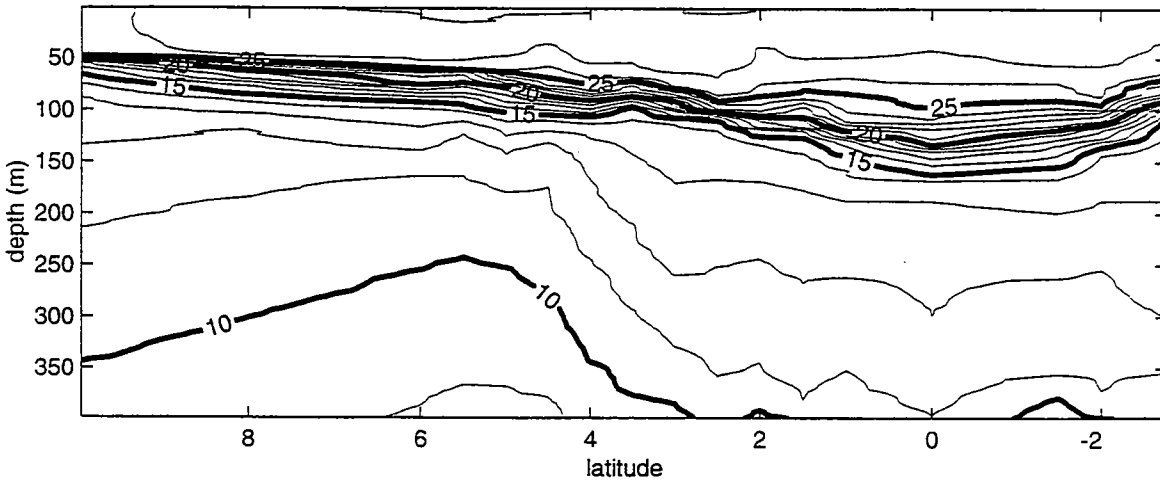

Pacs 1 CTD Section: Potential Density

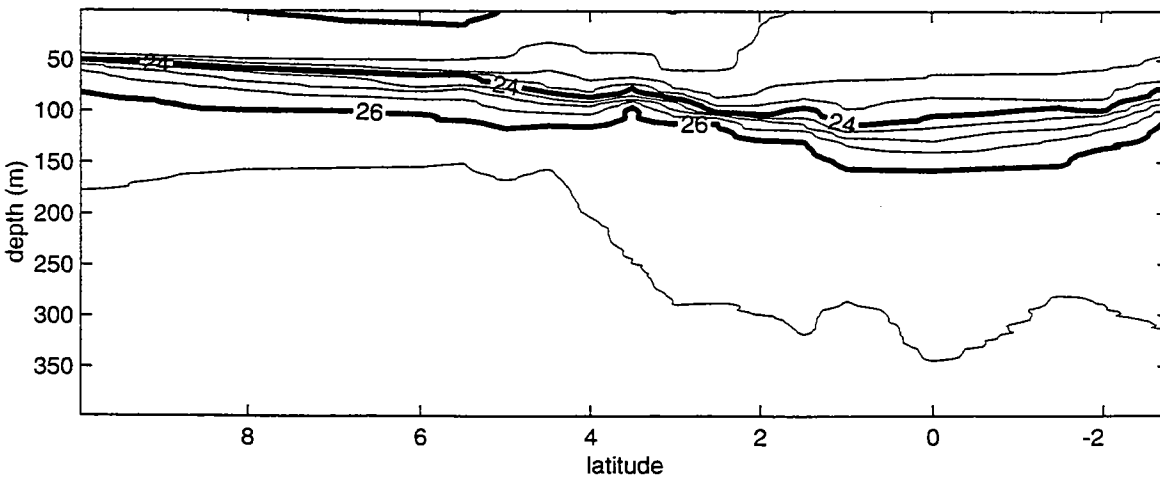

Figure A2-1: Composite plot of CTD data.

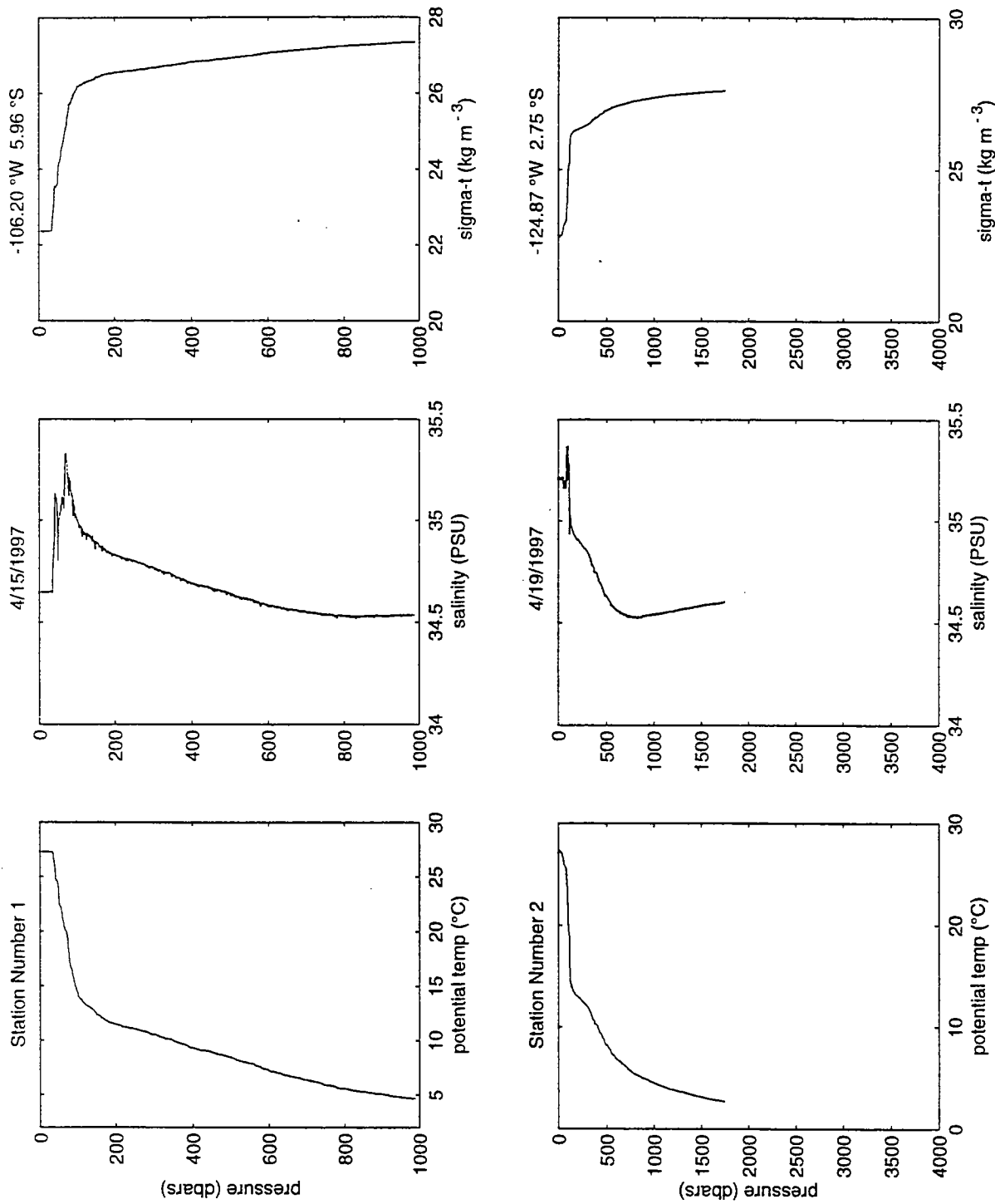

Figure A2-2: Profiles of potential temperature, salinity, and sigma-t from CTD stations 1 and 2.

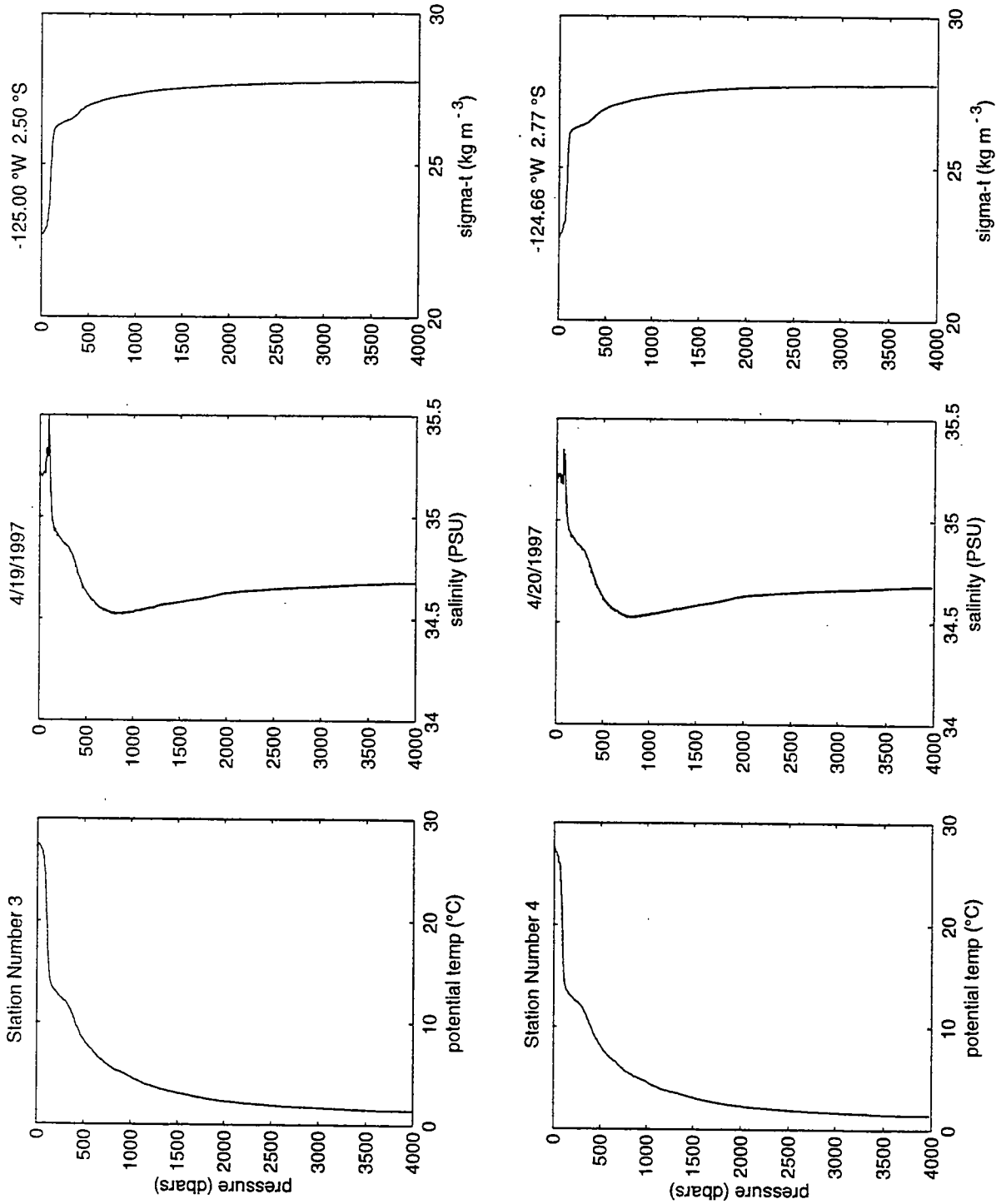

Figure A2-3: Profiles from CTD stations 3 and 4.

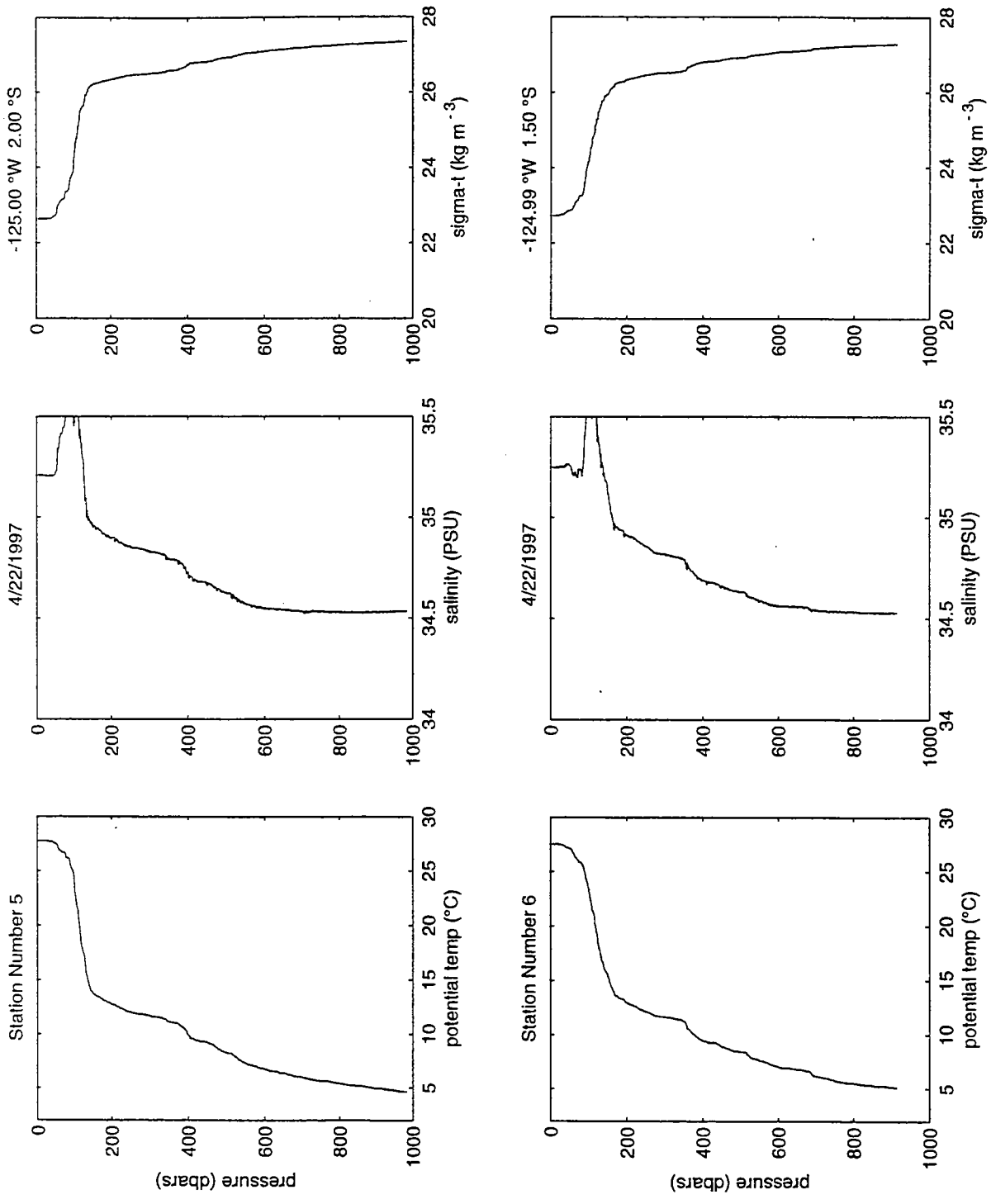

Figure A2-4: Profiles from CTD stations 5 and 6.

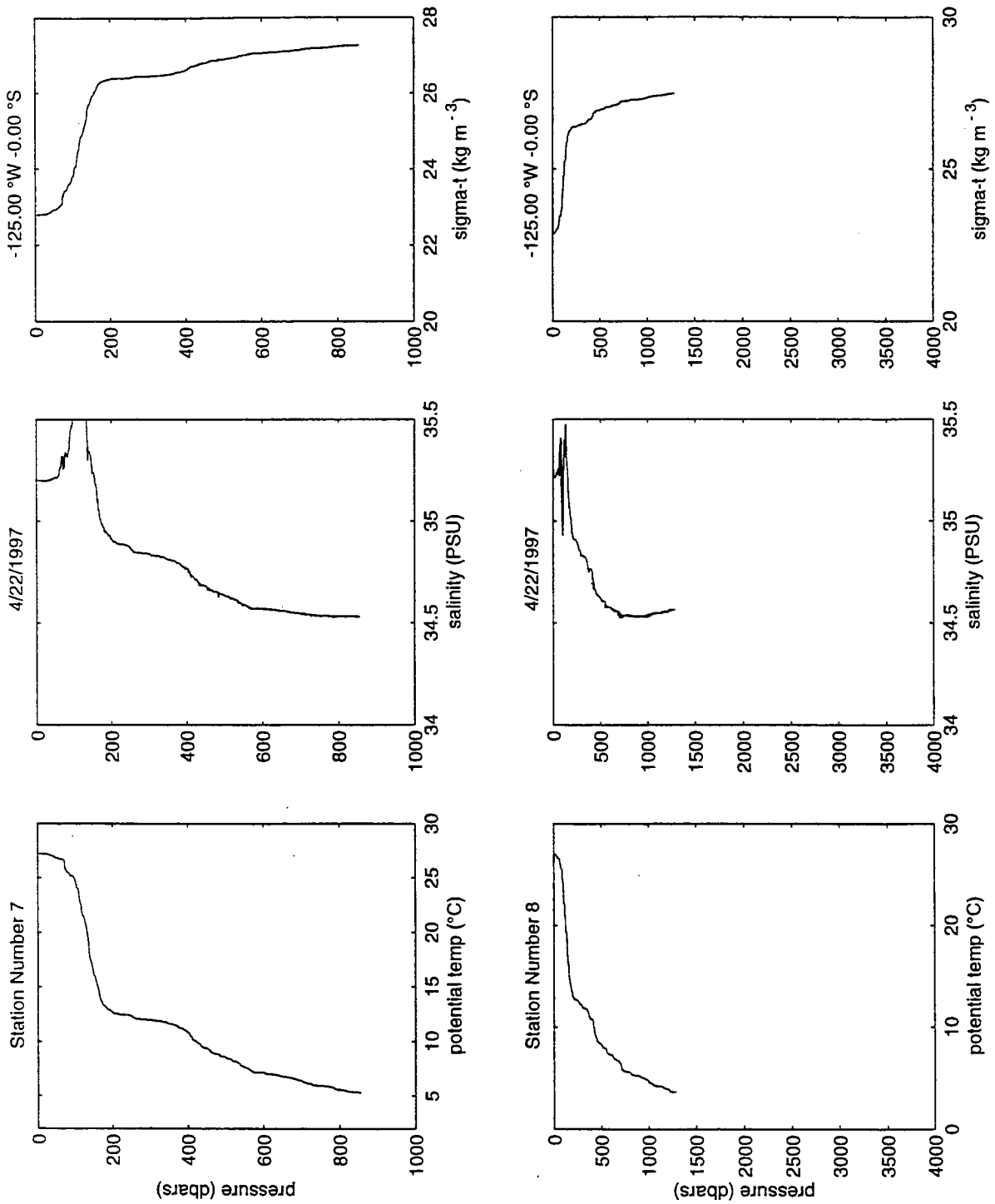

Figure A2-5: Profiles from CTD stations 7 and 8.

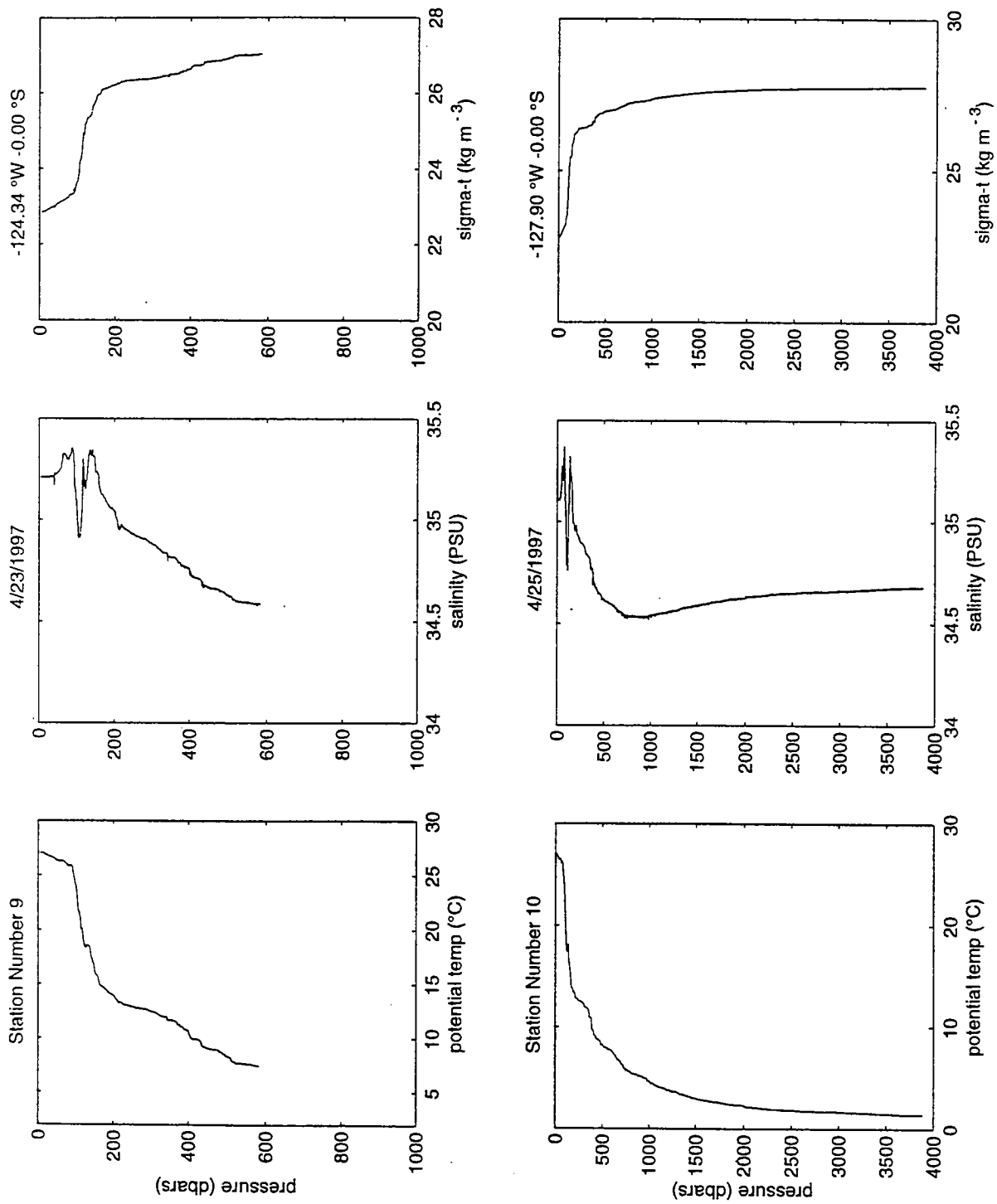

Figure A2-6: Profiles from CTD stations 9 and 10.



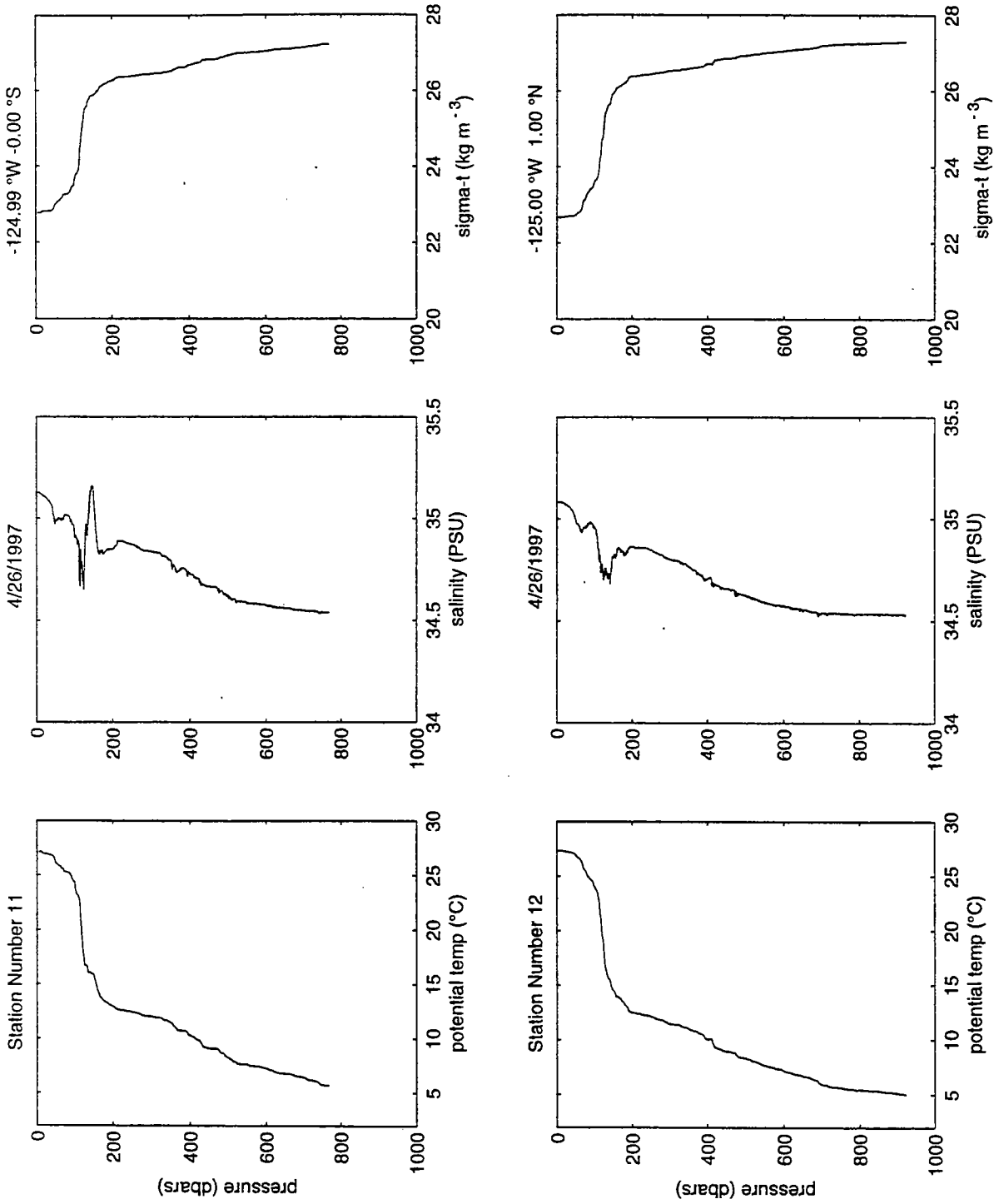

Figure A2-7: Profiles from CTD stations 11 and 12.

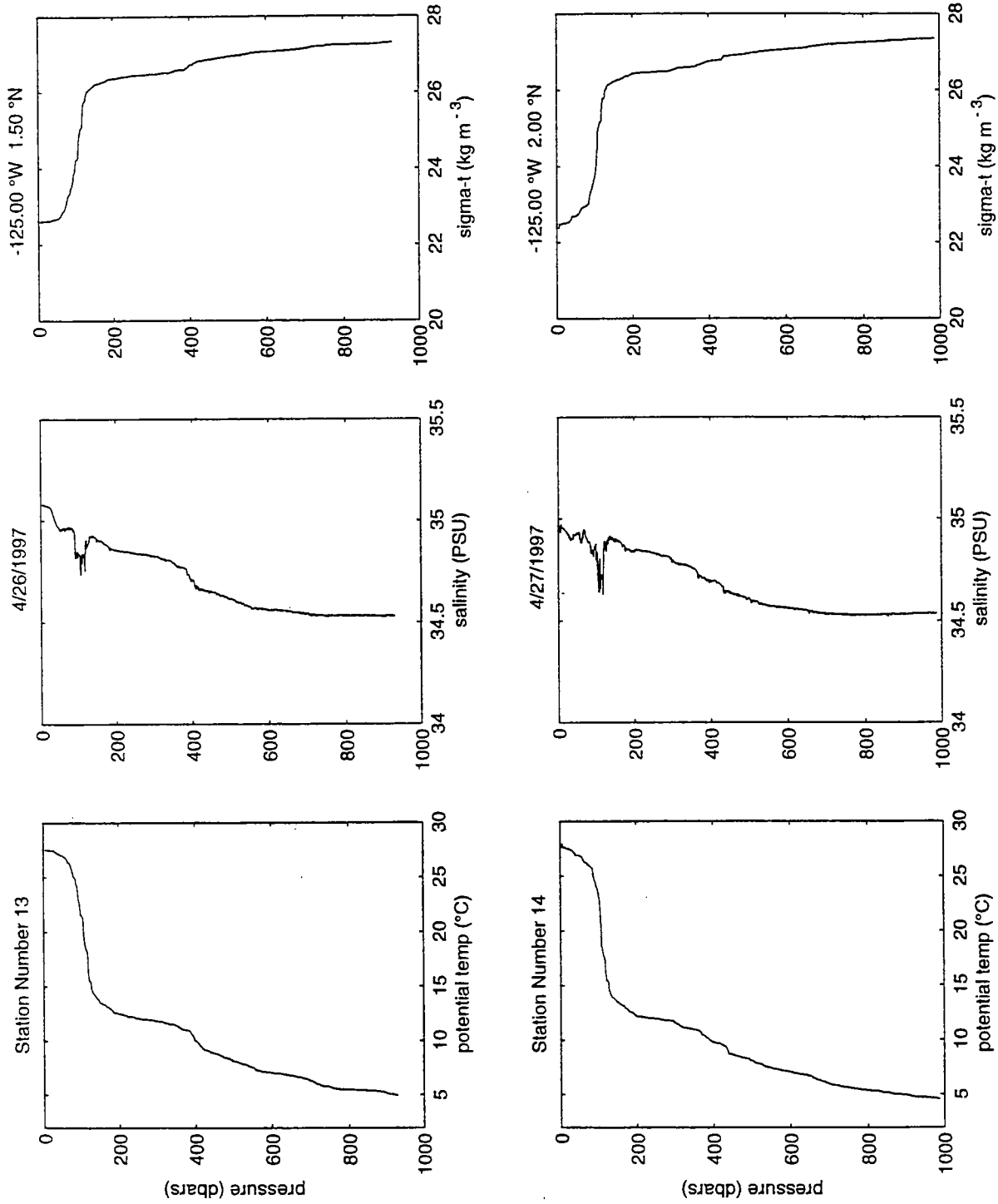

Figure A2-8: Profiles from CTD stations 13 and 14.

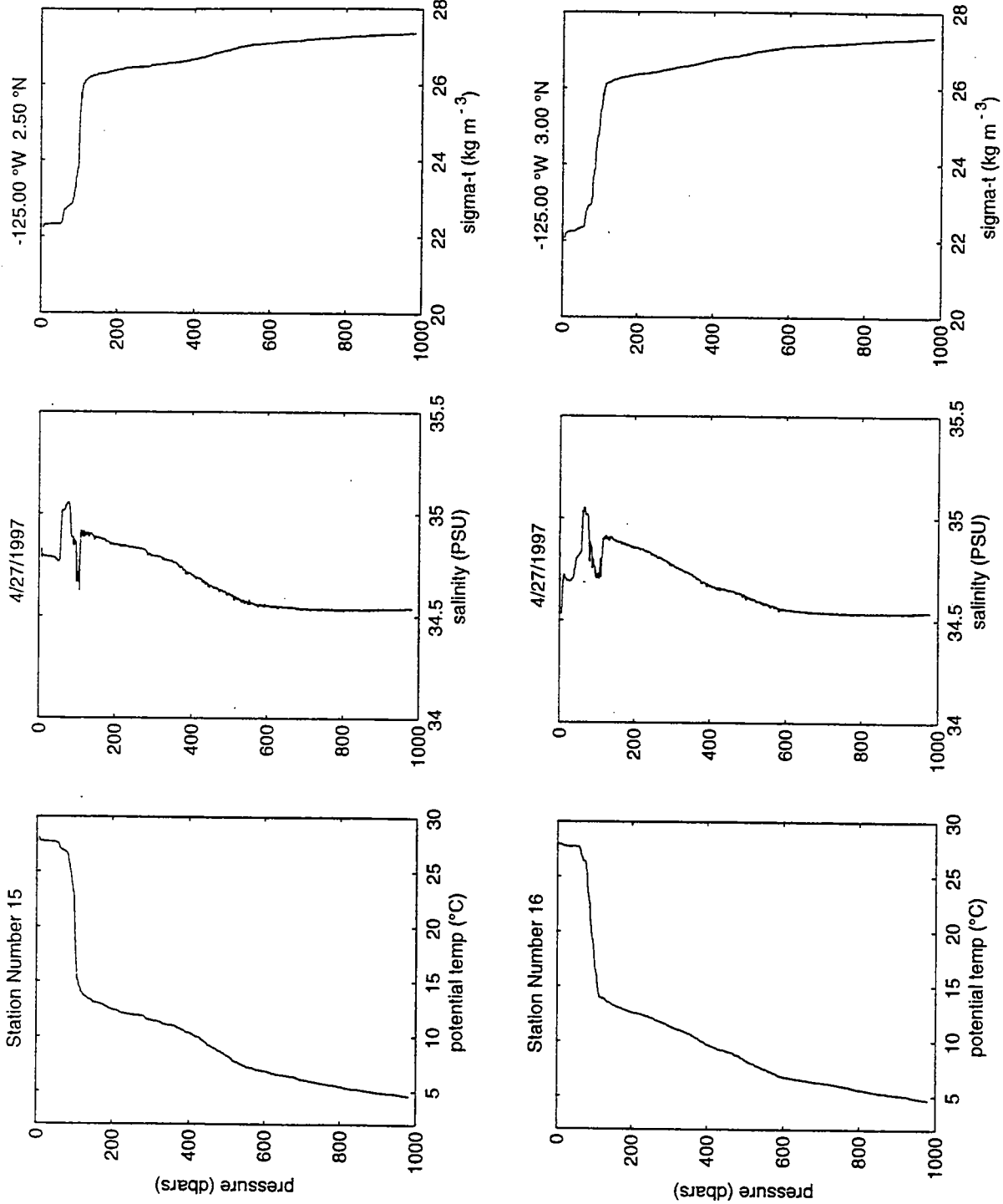

Figure A2-9: Profiles from CTD stations 15 and 16.

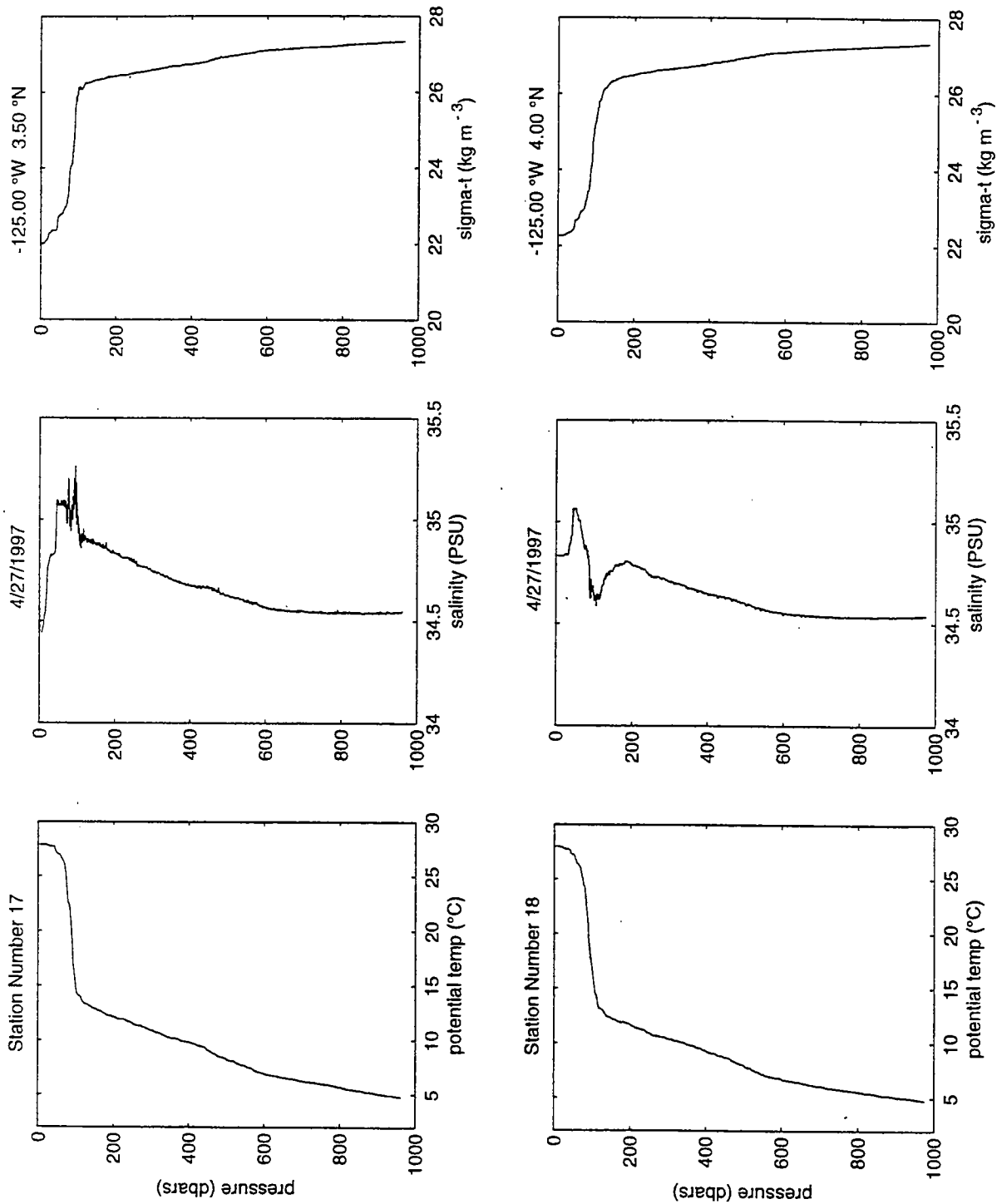

Figure A2-10: Profiles from CTD stations 17 and 18.

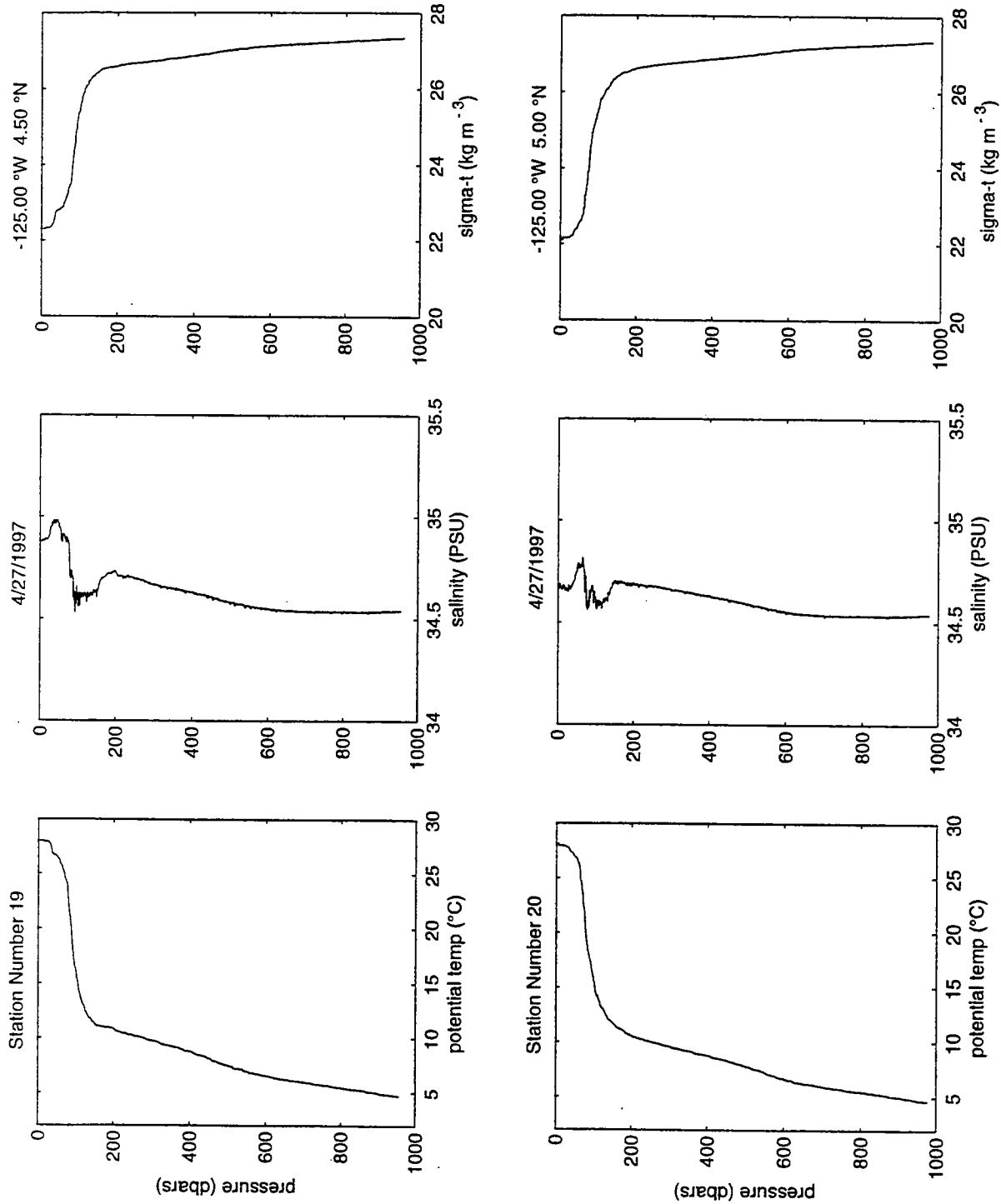

Figure A2-11: Profiles from CTD stations 19 and 20.

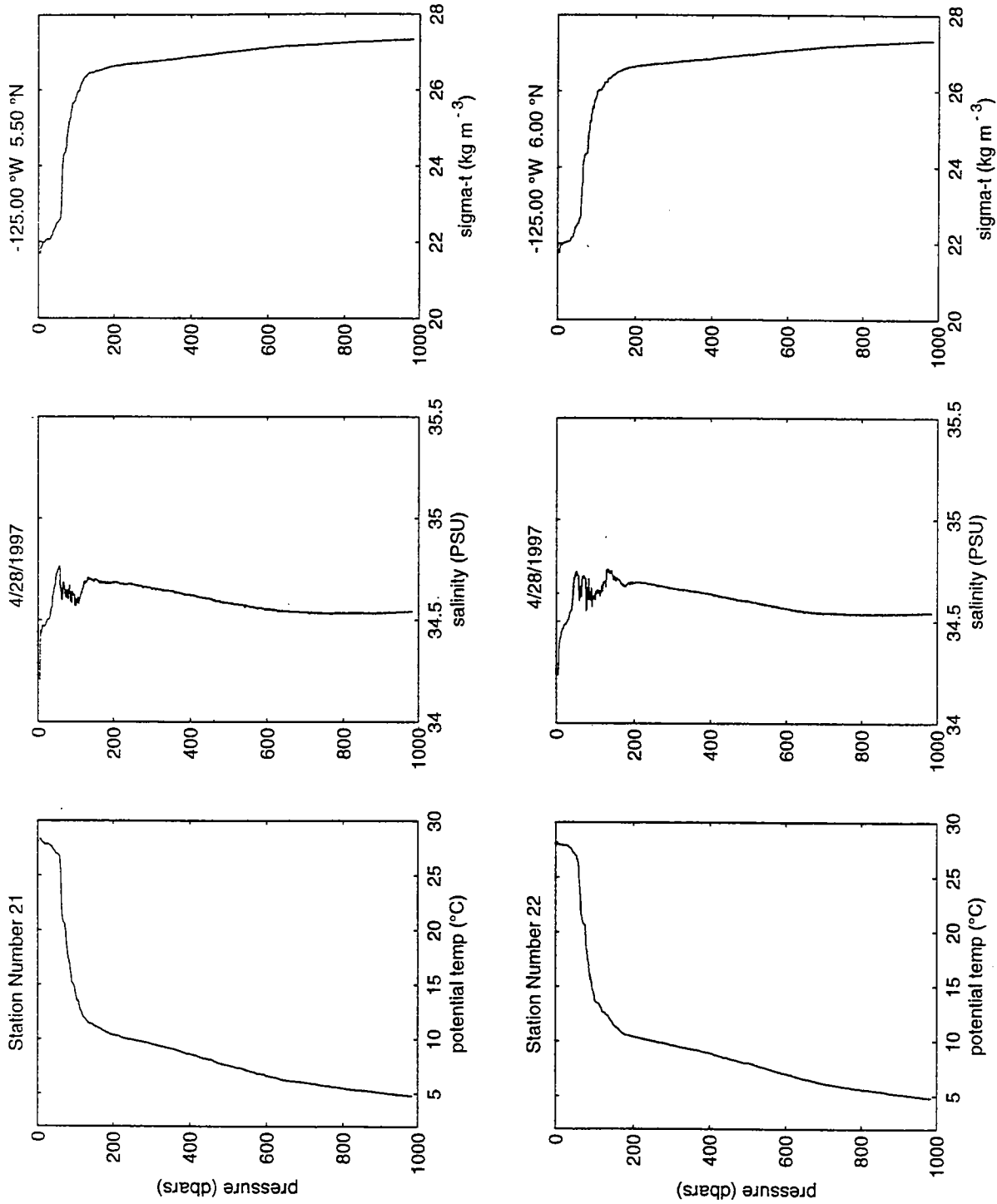

Figure A2-12: Profiles from CTD stations 21 and 22.

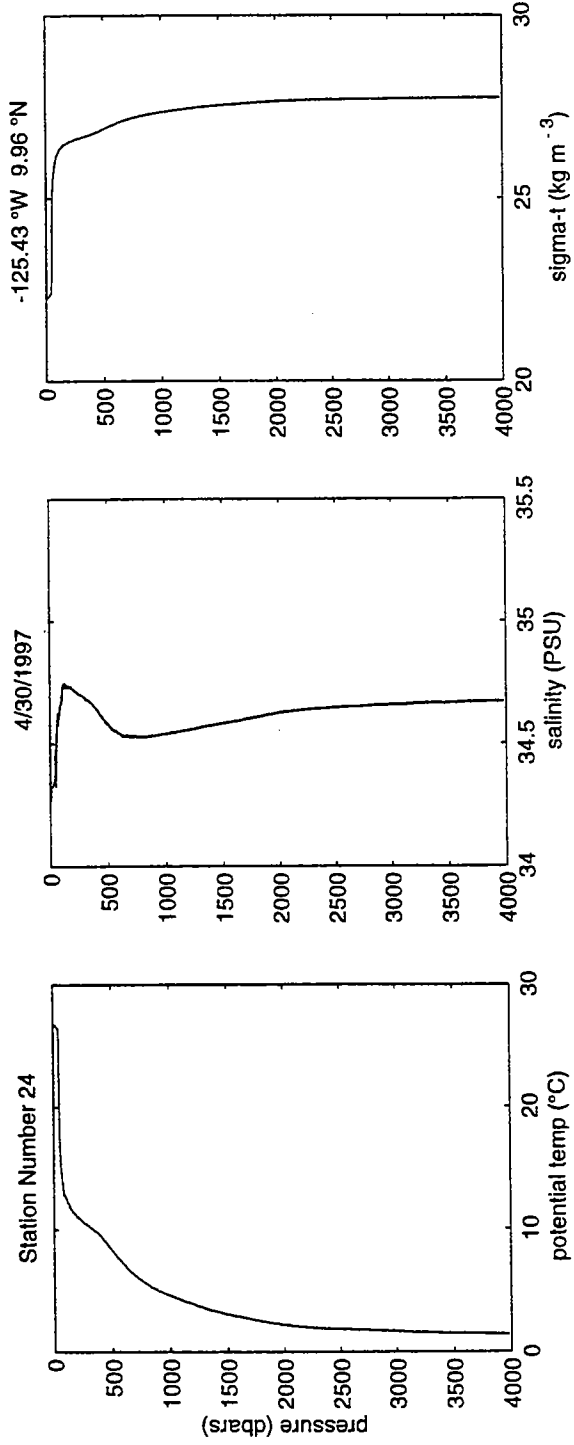
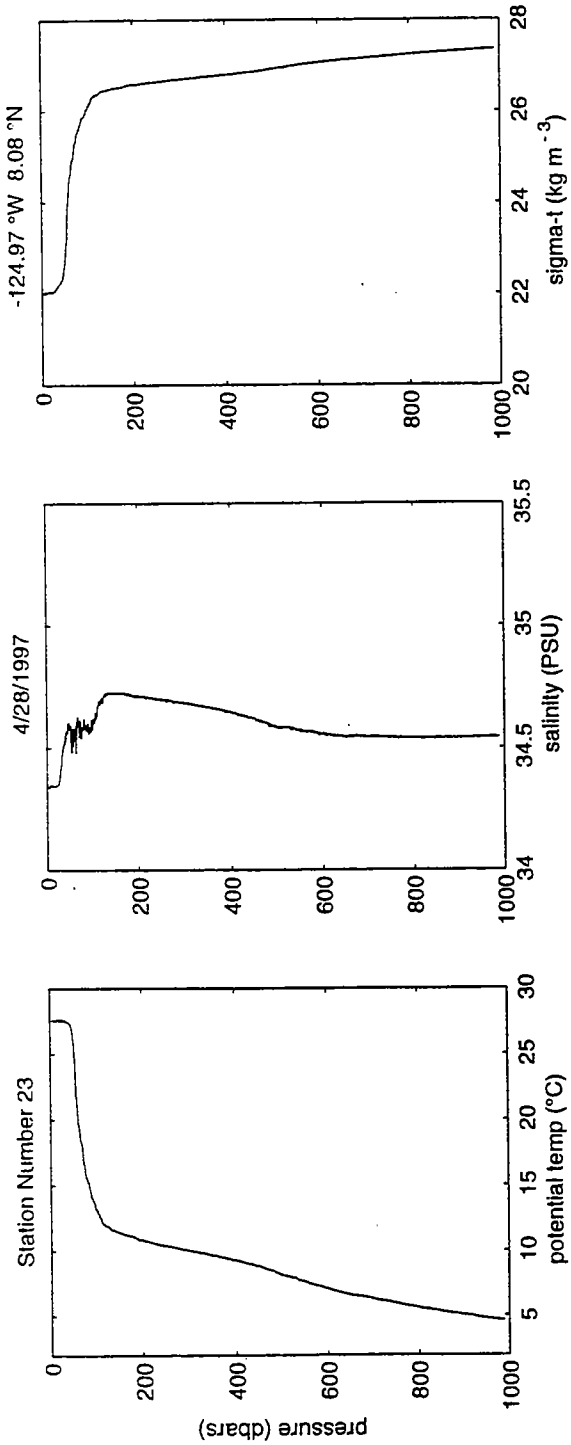

Figure A2-13: Profiles from CTD stations 23 and 24.

**Appendix 3**  
**WHOI instrumentation deployed during PACS 1**

Instrument No.	Mooring	Depth (meters)
<b>Brancker Temperature Recorders</b>		
3258	WHOI North	1.50
3259	WHOI North	7.50
3263	WHOI North	0.25
3265	WHOI South	17.50
3279	WHOI South	35.00
3309	WHOI North	45.00
3662	WHOI North	150.00
3667	WHOI South	60.00
3699	WHOI South	0.50
3701	WHOI South	1.00
3703	WHOI North	25.00
3704	WHOI North	2.50
3761	WHOI North	35.00
3762	WHOI South	200.00
3764	WHOI South	2.50
3835	WHOI South	0.25
3836	WHOI South	7.50
3838	WHOI North	2.00
3839	WHOI North	200.00
4481	WHOI North	17.50
4482	WHOI South	150.00
4483	WHOI North	1.00
4485	WHOI South	45.00
4487	WHOI North	100.00
4489	WHOI South	2.00
4491	WHOI North	0.50
4492	WHOI South	1.50
4494	WHOI South	25.00
4495	WHOI North	60.00



## VMCM

VM-008	WHOI South	90.00
VM-009	WHOI South	5.00
VM-011	WHOI South	10.00
VM-013	WHOI North	40.00
VM-014	WHOI North	15.00
VM-015	WHOI North	20.00
VM-016	WHOI North	5.00
VM-018	WHOI South	70.00
VM-019	WHOI North	110.00
VM-020	WHOI North	10.00
VM-021	WHOI South	110.00
VM-025	WHOI South	40.00
VM-026	WHOI North	90.00
VM-031	WHOI North	70.00
VM-032	WHOI South	50.00
VM-033	WHOI North	50.00
VM-037	WHOI North	30.00
VM-038	WHOI South	20.00
VM-039	WHOI South	30.00
VM-056	WHOI South	15.00

## SEACAT

143	WHOI South	1.71
928	WHOI North	12.50
929	WHOI South	32.50
991	WHOI South	22.50
992	WHOI North	32.50
993	WHOI South	12.50
994	WHOI North	1.86
995	WHOI North	22.50

MTR

3143	WHOI South	3.50
3240	WHOI North	3.50

WaDaR

274	WHOI South	Surface
275	WHOI North	Surface

MICROCAT

009	WHOI North	80.00
010	WHOI South	80.00

CHLAM

ACH0126	WHOI South	27.50
---------	------------	-------

FSI Current Meter

1428A	WHOI South	130.00
-------	------------	--------

SHERMAN Current Meter

001	WHOI South	120.00
-----	------------	--------

Rain Gauge

002	WHOI North	29.00
-----	------------	-------

## Appendix 4

### WHOI VMCM record format

#### 1. RECORD COUNTER (TIME)

The first 16 bits (4 characters) of data comprise the record number. The counter is incremented once each data record. The first record number is one (0001) and is used to initialize the instrument. The data and length of the first record may be invalid and should be ignored. Record two (0002) contains data for the first record interval. After 65535 records, the record counter will reset to zero and begin its normal counting.

#### 2. NORTH VECTOR

Each vector is scaled from a 24-bit accumulator and stored in a 16-bit floating-point representation. This vector is the algebraic sum of the NORTH component of current flow from each sample.

#### 3. EAST VECTOR

Each vector is scaled from a 24-bit accumulator and stored in a 16-bit floating-point representation. This vector is the algebraic sum of the EAST component of current flow from each sample.

#### 4. ROTOR 2 (X CURRENT FLOW) (UPPER)

The rotor counts are an algebraic sum of the counts for a record interval. Rotor counts are scaled from a 24-bit accumulator and stored as a 16-bit floating number.

#### 5. ROTOR 1 (Y CURRENT FLOW) (LOWER)

The rotor counts are an algebraic sum of the counts for a record interval. Rotor counts are scaled from a 24-bit accumulator and stored as a 16-bit floating number.

#### 6. COMPASS

The compass field is an 8 bit 2's complement number (-128 to +128 decimal). The stored value is measured at the beginning of the last sample of the record interval.

#### 7. TEMPERATURE

One temperature sample is taken at the beginning of each record interval.

**Record interval** = 2 seconds to 2 hours

**Sample interval** = .25 seconds to 2 seconds in quarter second steps

**PREAMBLE/ TIME/ NORTH/ EAST/ R2/ R1/ COMPASS/ TEMP./ PARITY**

(2)        (4)        (4)        (4) (4) (4)        (2)        (4)        (1)

(X) = Number of characters

## Appendix 5

### PACS mooring deployment procedure

The PACS North and South surface moorings, deployed from the R/V *Roger Revelle*, were set using the UOP, two-phase mooring technique. Phase 1 involved the lowering of approximately 40 meters of instrumentation over the port side of the ship; and phase 2, the deployment of the buoy into the sea. The benefits from lowering the first 40 meters of instrumentation are three fold: (1) It allows for the controlled lowering of the upper instrumentation; (2) The suspended instrumentation, attached to the buoy's bridle, acts as a sea anchor to stabilize the buoy during the deployment of the buoy; and (3) the 80-meter length of paid out mooring wire provides adequate scope for the buoy to clear the stern without capsizing or hitting the ship.

The basic deck equipment and deck layout are illustrated in Figure A5-1. The mooring gear used in the deployment of the surface moorings included: the Lebus winch system, crane on the 01-level deck, HIAB crane, Yale grips and the standard complement of chain grabs, stoppers and slip lines.

The personnel utilized during the first phase of the operation included: a deck supervisor, three Lebus winch operators, four mooring wire handlers, crane-whip operator, a HIAB crane operator and a 01-deck crane operator. Figure A5-2 illustrates the positioning of personnel during the instrument-lowering phase.

For this narrative the southern mooring (Figure 5) is used to describe the deployment procedures utilized for both the north and south WHOI moorings. Prior to the deployment of the southern mooring, a 150-meters length of 3/8" diameter wire rope was measured and four Yale grips were woven at 31 meters, 36 meters, 41 meters, and 46 meters from the swage fitting. (Yale grips are a multi-strand Kevlar eye splice that can be spliced mid-span onto wire or line.) The grips provide the wire handler at the rail a better holding point on the hauling wire during the instrument-lowering phase of the deployment. This wire shot, or hauling wire, was pre-wound onto a wooden reel, with Yale grips on top of the reel. The reel was secured to the Lebus spooler and the bitter end of the wire paid out and reeved five wraps around the Lebus capstan winch. The hauling wire was then paid out to allow its bitter end to be passed out through the center of the A-frame and around the aft port quarter and up forward along the port rail to the instrument lowering area Figure A5-2.

The four hauling-wire handlers were positioned around the aft port rail. Their positions were in front of the Lebus capstan, the center of the A-frame, aft port quarter, and approximately eight meters forward along the port rail. The wire handlers' job was to keep the hauling wire from fouling in the ship's propellers.

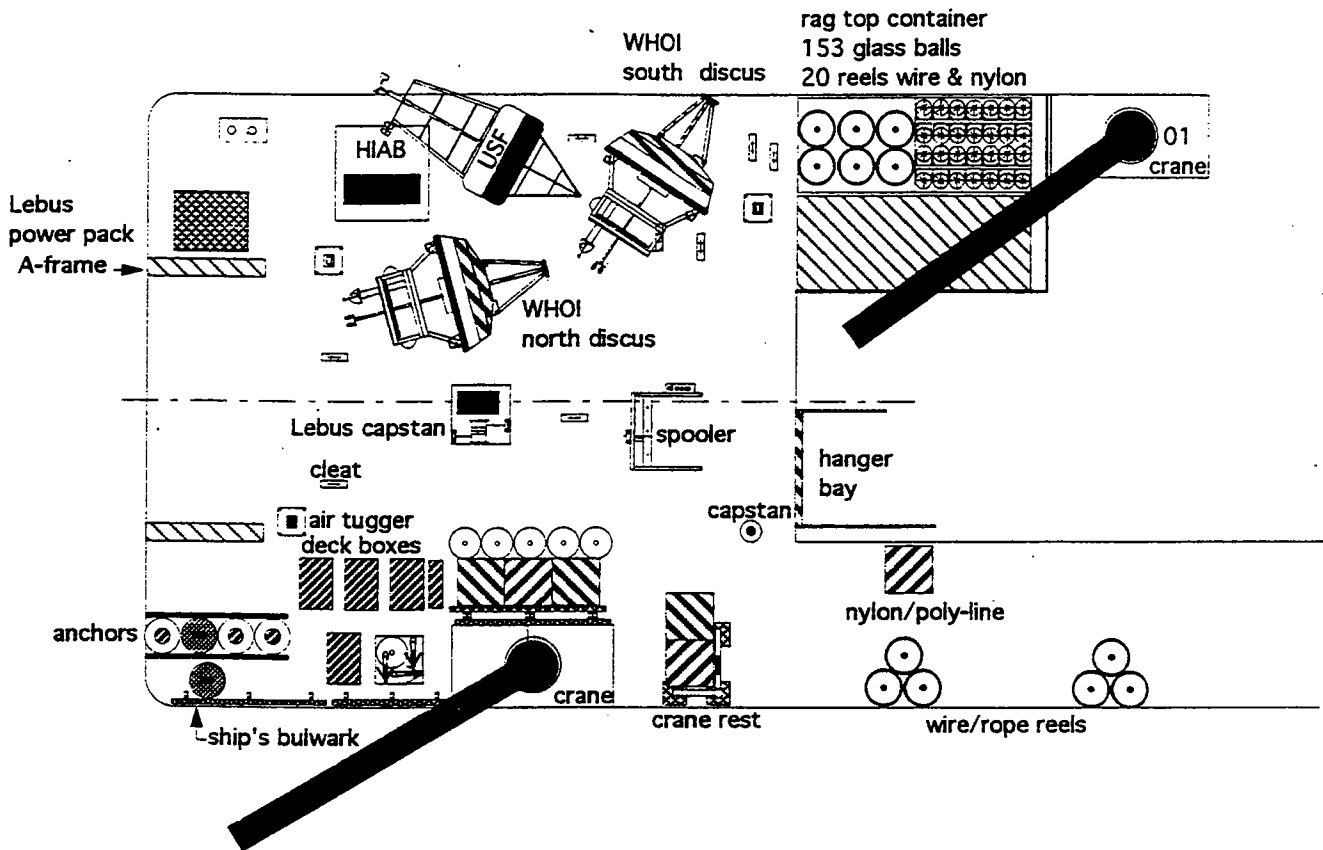

- Science Gear Weights**
- 5 deck box 5800 lbs.
  - 2 USF anchor 9000 lbs.
  - 3 UOP anchor 27900 lbs.
  - 1 USF toriod 2500 lbs.
  - 2 UOP discus 5400 lbs.
  - 1 Lebus power pack 4500 lbs.
  - 1 Lebus capstan 4900 lbs.
  - 1 Lebus spooler 2000 lbs.
  - 35 wire/nylon reels 7000 lbs.
  - 3 air tiggers 900 lbs.
  - 153 glass balls & van 20600 lbs.
  - 1 dragging gear 2000 lbs.

PACS  
 Weller-Weisberg  
 4/13/97  
 W.Ostrom  
 departure layout  
 92500 lbs.  
 scale 1"= 15'

Figure A5-1: PACS deployment deck layout.

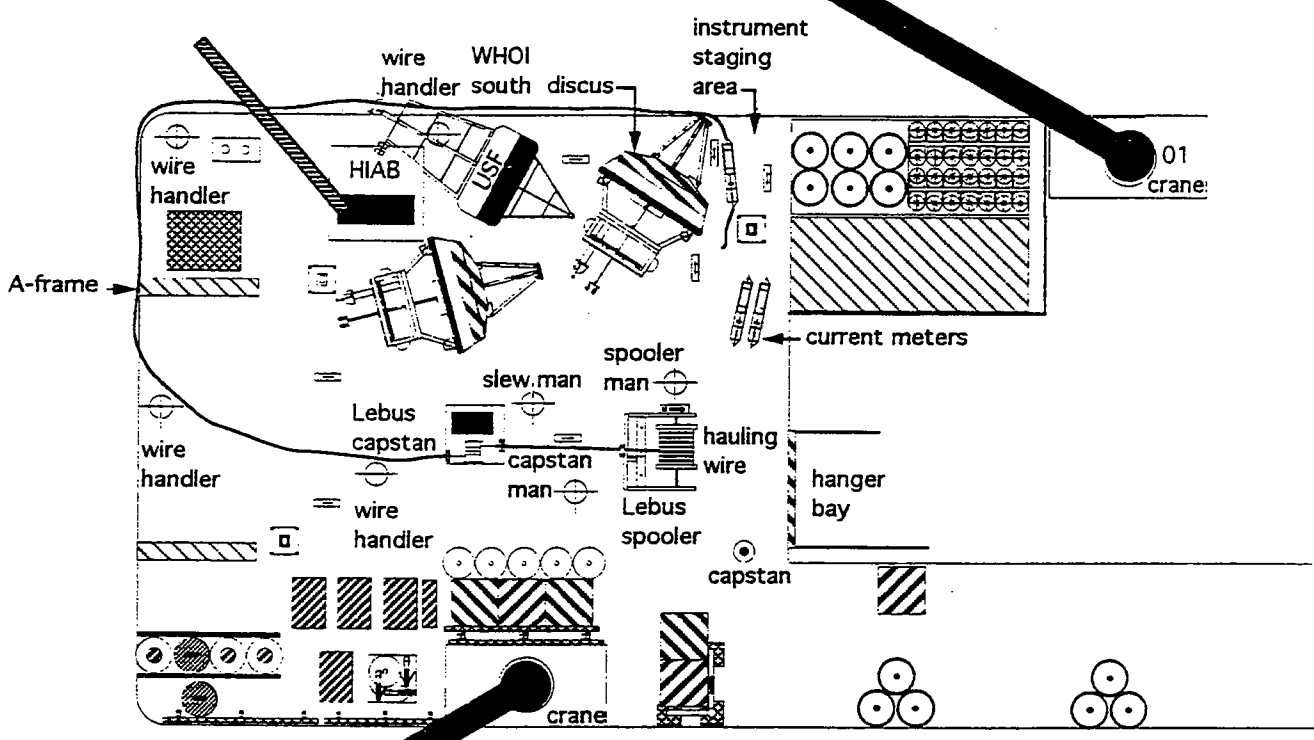

scale 1" = 15'

Figure A5-2: Personnel work stations during surface buoy deployments.

The HIAB crane located on the fantail's port side was used as an outrigger, hooking the last Yale grip to a Release-A-Matic quick release hook, which was secured to the HIAB boom. The crane's boom was articulated so that it would reach 15 feet over the port aft quarter. The port aft quarter wire handler was responsible for attaching the last Yale grip to the hook and releasing this grip and hauling wire once the discus had been deployed and had drifted clear of the ship's propellers.

Prior to the start of the operation the ship's bow was positioned up wind with minimal way during the instrument-lowering phase. The 01-deck crane was extended out so that there was a minimum of ten meters of free whip hanging over the instrument-lowering area.

The Lebus winch had three operators: capstan, slue, and spooler. Their duties entailed the paying out of the hauling wire at a similar speed to that of the 01-level crane's whip. The instrument lowering commenced by shackling the bitter end of the hauling wire to the 7.4-meter length of 7/16" wire rope. The free end of 7.4-meter wire rope was then shackled to the bottom of the 40-meter VMCM. The 5.8-meter shot of 7/16" wire rope, 35-meter depth Brancker temperature recorder, 32.5-meter depth SEACAT and .3-meter 3/4" chain were then connected to the top of the 40-meter VMCM. The crane whip was hooked near the top of the chain shot using a 3/4" chain grab and sling. This was done with the 01-crane in the extended position. The crane whip then raised the chain and attached instrumentation until the entire length was vertical and approximately .5 meters off the deck. The crane was instructed to swing outboard one meter to clear the ship's side and slowly lowered its whip and attached mooring components down into the water. The Lebus winch simultaneously paid out the hauling wire. The wire handlers positioned around the stern tended the hauling wire, easing it over the port side and allowing only enough wire over the side to keep the lowered mooring segment vertical in the water. The chain was stopped off when the chain-grabbed end was .5 meters above the ship's deck. The crane was then directed to swing slightly inboard. A stopper line, with a Renfro snap hook, was hooked into the loose end link shackled to the bitter end of the 3/4" chain and secured to a deck cleat. The whip was then lowered, transferring the tension to the stopper line.

The next segment in the mooring to be lowered included the 30-meter VMCM, the CHLAM and .5 meters of 3/4" chain. The instruments were brought into the instrument-lowering area with their bottom ends pointing outboard so that it could be shackled in series to the top of the stopped-off chain shot. The loose end of the chain, fitted with a 3/4" chain shackle and 7/8" end link, was again hooked onto the crane whip using a chain grab. The crane whip was then raised, taking with it the chain and instruments into a vertical position .5 meters off the deck. Once the crane's whip had taken the load off the mooring components and they were hanging over the side, the stopper line was slackened and removed. The crane was then swung out board and the whip lowered. The Lebus winch slowly paid out the hauling wire.

The operation of lowering the upper mooring components in conjunction with the pay out of the hauling wire was repeated up to the upper .4-meter shot which was shack-

led to the MTR temperature logger. At this point the chain segment attached to the MTR was stopped off to the deck with a chain grab, leaving enough slack in the assembly to be shackled to the discus universal joint attached to the bridle.

At this point in the deployment the last Yale grip was hooked into a quick release hook which was hung from the HIAB crane boom. The crane then extended outboard over the aft port rail keeping the hauling wire well away from the side of the ship.

The second phase of the operation was the launching of the discus buoy. There were three slip lines rigged on the discus to maintain constant swing control during the lift. One was positioned on the bridle, tower bail and a buoy deck bail (Figure A5-3). The 30-foot bridle slip line was used to stabilize the bridle and allow the hull to pivot on the bridle's apex at the start of the lift. The 60-foot tower slip line was rigged to check the tower swing as the hull swung outboard. A 75-foot buoy deck bail slip line was the most important of all the slip lines. This line prevented the buoy from spinning as the buoy settled out in the water. This is important in order for the quick release hook, hanging from the crane's whip, could be released without fouling. The buoy deck bail slip line was removed just following the release of the discus into the sea. One additional line, called the whip tag line, was used in this operation. The whip tag line kept the whip away from the tower's meteorological sensors once the quick release hook had been pulled free and the discus was cast adrift.

The personnel utilized for this phase of the operation included: a deck supervisor, two Lebus winch operators, two hauling wire handlers, three slip line handlers, an 01-deck crane operator, a HIAB crane operator, a crane whip tag line handler, and an operator for the quick release hook.

With all three slip lines in place, the crane was directed to swing over the discus buoy. The extension of the crane's boom was approximately 60 feet. The crane's whip was lowered to the discus, and the quick release hook was attached to the main lifting bail. Slight tension was taken up on the whip in order to take hold of the buoy. The chain lashings, binding the discus to the deck, were removed. The stopper line holding the suspended 40 meters of mooring string was eased off to allow the discus to take on that hanging tension. The discus was raised up and swung outboard as the slip lines kept the hull in check. The bridle slip line was removed first followed by the tower bail slip line. Once the discus had settled into the water (approximately 20 feet from the side of the ship) and the release hook had gone slack, the quick release hook operator pulled the trip line and cleared the whip away from the buoy (forward) with the help of the whip tag line handler. The slip line to the buoy deck bail should be cleared at about the same time the quick release hook is tripped or slightly before. If the discus were released prior to the buoy settling out in the water, the tower could swing into the whip and cause potential damage to the tower sensors. The ship then maneuvered slowly ahead to allow the discus to pass around the stern of the ship. The HIAB crane holding the Yale grip on the hauling wire was cast off once the buoy had drifted aft to a position just forward of its extended boom.



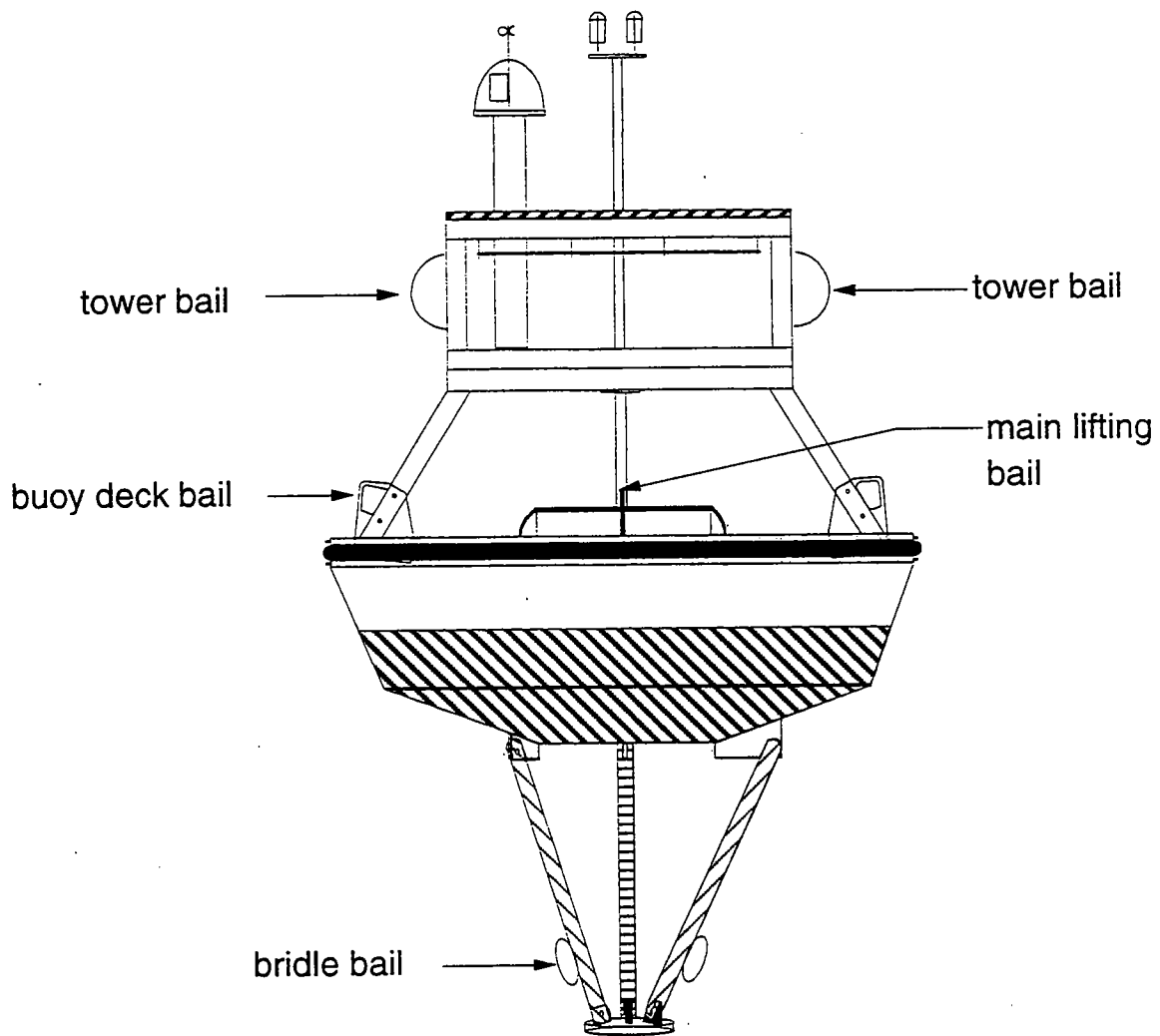

**Figure A5-3: UOP discus bail configuration.**

The Lebus operator was instructed to slowly haul in the hauling wire once the discus had straightened out behind the ship. The ship's speed was at that time increased to one knot through the water in order to maintain safe distance between the discus and the ship. Once this had occurred the bottom end of the 7.4-meters shot of 7/16" wire rope (Figure 3) shackled to the hauling wire was hauled in and stopped off at the transom. The next instrument was brought out and shackled to the bitter end of the stopped-off wire rope. At this point the remainder of the mooring was deployed using the WHOI Buoy Group's winch-to-deck stopper technique (Heinmiller, 1976)

*Miscellaneous Notes*

During all the deployments a digital tachometer, Ametek model #1726, was used in the calculation of mooring pay out speed verses the ship's speed through the water. This tool was used as a check to verify that the mooring was always being slightly towed during deployment. The tachometer utilized a rotating wheel, which was manually placed against the wire or nylon rope being paid out over the stern. The selected readout from the tachometer was in miles per hour. Table A5-1 shows a given ship's speed and the corresponding tachometer reading.

**Table A5-1: PACS mooring payout speed chart**

Ship's speed	Payout Meter Readings*
0.25	0.24
0.5	0.49
0.75	0.73
1	0.97
1.25	1.21
1.5	1.46
1.75	1.7
2	1.94
2.25	2.19
2.5	2.43
2.75	2.68
3	2.92

10% less than ship's speed; takes into consideration nautical miles versus statute mile.  
 10% reduction to prevent paying out faster than ship's speed.

## Appendix 6

### PACS antifouling coating test

For the past seven years the UOP Group has used Ameron 635 tributyltin-based antifouling paint on aluminum buoy hulls and sub-surface instrumentation to prevent fouling for up to eight months. Recently this antifouling coating has been taken out of production, and an alternate coating is being sought.

The PACS North and South discus hull bottoms were used as test surfaces for an intercomparison test between three antifouling paints. The coatings tested were: Pettit Alumacoat II; Ameron 635; and No Foul SN-1. The biocide used in the Pettit and Ameron paints is tributyltin. Both the Pettit and Ameron paints are federally regulated in their application and use. No Foul SN-1 is a vinyl copolymer antifouling paint that is free of copper and tributyltin. This paint has been reported to have good antifouling capabilities without the hazardous handling problems characteristic in the other two coatings. The purpose of this field test was to find an alternative to tributyltin-based antifouling paint that is environmentally safer in its application and use.

The buoy hulls were painted so that coatings would be subjected to similar current flow and swell impact around the hull. Figure A6-1 details the paint scheme used. Three coats of each paint type were applied by brush and hand roller. The dry mil thickness of the paints was approximately six mils. The tie coat on which the antifouling coatings were painted was Ameron PSX 700, a high-build siloxane coating.

The floating sea-surface temperature frame and WaDaR float were painted with Ameron 635. The Brancker temperature pod pipe and the solar shield plates for the near surface, six Branckers were painted with No Foul SN-1. Following attachment of the solar-shielded Branckers onto the temperature pod pipe, the instruments and solar shields were spray painted with a tributyltin-based antifouling paint, Interlux Yacht Classic 2837. This was done for additional protection against fouling. The discus bridle legs and attached sensor brackets were coated with No Foul SN-1. The VMCM instrument cage rods, instrument stings and fans were spray painted with two coats of Pettit Alumicoat II. All the Brancker temperature recorder thermistor end caps were hand-painted with Ameron 635. The Brancker wire clamp brackets were painted with No Foul SN-1.

At the conclusion of the nine-month deployment, the antifouling paints on the discus hull will be evaluated for ablation rate, marine fouling and propagation of corrosion.



## DOCUMENT LIBRARY

*Distribution List for Technical Report Exchange – July 1998*

University of California, San Diego  
SIO Library 0175C  
9500 Gilman Drive  
La Jolla, CA 92093-0175

Hancock Library of Biology & Oceanography  
Alan Hancock Laboratory  
University of Southern California  
University Park  
Los Angeles, CA 90089-0371

Gifts & Exchanges  
Library  
Bedford Institute of Oceanography  
P.O. Box 1006  
Dartmouth, NS, B2Y 4A2, CANADA

NOAA/EDIS Miami Library Center  
4301 Rickenbacker Causeway  
Miami, FL 33149

Research Library  
U.S. Army Corps of Engineers  
Waterways Experiment Station  
3909 Halls Ferry Road  
Vicksburg, MS 39180-6199

Marine Resources Information Center  
Building E38-320  
MIT  
Cambridge, MA 02139

Library  
Lamont-Doherty Geological Observatory  
Columbia University  
Palisades, NY 10964

Library  
Serials Department  
Oregon State University  
Corvallis, OR 97331

Pell Marine Science Library  
University of Rhode Island  
Narragansett Bay Campus  
Narragansett, RI 02882

Working Collection  
Texas A&M University  
Dept. of Oceanography  
College Station, TX 77843

Fisheries-Oceanography Library  
151 Oceanography Teaching Bldg.  
University of Washington  
Seattle, WA 98195

Library  
R.S.M.A.S.  
University of Miami  
4600 Rickenbacker Causeway  
Miami, FL 33149

Maury Oceanographic Library  
Naval Oceanographic Office  
Building 1003 South  
1002 Balch Blvd.  
Stennis Space Center, MS, 39522-5001

Library  
Institute of Ocean Sciences  
P.O. Box 6000  
Sidney, B.C. V8L 4B2  
CANADA

National Oceanographic Library  
Southampton Oceanography Centre  
European Way  
Southampton SO14 3ZH  
UK

The Librarian  
CSIRO Marine Laboratories  
G.P.O. Box 1538  
Hobart, Tasmania  
AUSTRALIA 7001

Library  
Proudman Oceanographic Laboratory  
Bidston Observatory  
Birkenhead  
Merseyside L43 7 RA  
UNITED KINGDOM

IFREMER  
Centre de Brest  
Service Documentation - Publications  
BP 70 29280 PLOUZANE  
FRANCE



<b>REPORT DOCUMENTATION PAGE</b>	<b>1. REPORT NO.</b> WHOI-98-07	<b>2.</b> UOP-98-01	<b>3. Recipient's Accession No.</b>
<b>4. Title and Subtitle</b> Pan American Climate Study (PACS) Mooring Deployment Cruise		<b>5. Report Date</b> April 1998	
<b>7. Author(s)</b> Bryan S. Way, William M. Ostrom, Robert A. Weller, Jonathan D. Ware, Richard P. Trask, Rick Cole, Jeff Donovan		<b>8. Performing Organization Rept. No.</b> WHOI-98-07	
<b>9. Performing Organization Name and Address</b>  Woods Hole Oceanographic Institution Woods Hole, Massachusetts 02543		<b>10. Project/Task/Work Unit No.</b>  <b>11. Contract(C) or Grant(G) No.</b> (C) NA66GPO130 (G)	
<b>12. Sponsoring Organization Name and Address</b>  National Oceanic and Atmospheric Administration		<b>13. Type of Report &amp; Period Covered</b> Technical Report	
<b>15. Supplementary Notes</b> This report should be cited as: Woods Hole Oceanog. Inst. Tech. Rept., WHOI-98-07			
<b>16. Abstract (Limit: 200 words)</b>  Three surface moorings were deployed in the eastern equatorial Pacific from the R/V <i>Roger Revelle</i> as part of the Pan American Climate Study (PACS). PACS is a NOAA-funded study with the goal of investigating links between sea surface temperature variability in the tropical oceans near the Americas and climate over the American continents. The three moorings were deployed near 125°W, spanning the strong meridional sea surface temperature gradient associated with the cold tongue south of the equator and the warmer ocean north of the equator, near the northernmost, summer location of the Intertropical Convergence Zone. The mooring deployment was done to improve understanding of the air-sea fluxes and of the processes that control the evolution of the sea surface temperature field in the region.  Two surface moorings of the Upper Ocean Processes Group at the Woods Hole Oceanographic Institution (WHOI) were deployed—one at 3°S, 125°W and the other at 10°N, 125°W. One mooring from the Ocean Circulation Group (R. Weisberg) at the University of South Florida (USF) was deployed on the equator at 128°W.  The buoys of the two WHOI moorings were each equipped with meteorological instrumentation, including a Vector Averaging Wind Recorder, and an Improved Meteorological (IMET) system. The WHOI moorings also carried Vector Measuring Current Meters, single-point temperature recorders, and conductivity and temperature recorders located in the upper 200 meters of the mooring line. In addition to the instrumentation noted above, a variety of other instruments, including an acoustic current meter, acoustic doppler current meters, bio-optical instrument packages and an acoustic rain gauge, were deployed during the PACS field program. The USF mooring had an IMET system on the surface buoy and for oceanographic instrumentation, two RD Instruments acoustic doppler current profilers, single-point temperature recorders, and conductivity and temperature recorders. Conductivity-temperature-depth (CTD) profiles were made at each mooring site and during the transit between mooring locations.  This report describes, in a general manner, the work that took place during the Genesis 4 cruise aboard the R/V <i>Roger Revelle</i> . The three surface moorings deployed during this cruise will be recovered and re-deployed after approximately nine months, with a final recovery planned for 17 months after the first setting. Details of the mooring designs and preliminary data from the CTD profiles are included.			
<b>17. Document Analysis</b> <p><b>a. Descriptors</b></p> air-sea interaction moored instrument measurements PACS: eastern tropical Pacific <p><b>b. Identifiers/Open-Ended Terms</b></p> <p><b>c. COSATI Field/Group</b></p>			
<b>18. Availability Statement</b>  Approved for public release; distribution unlimited.		<b>19. Security Class (This Report)</b> UNCLASSIFIED	<b>21. No. of Pages</b> 71
		<b>20. Security Class (This Page)</b>	<b>22. Price</b>

