

Woods Hole Oceanographic Institution

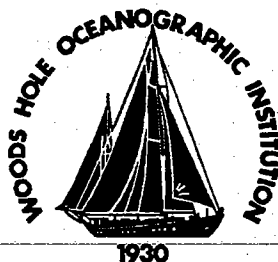

Pressure/Temperature Logger (PTL) Development and Field Deployment for the Great Bay, NH, Tidal Dynamics Experiment

by

Carl T. Friedrichs¹, Wayne D. Spencer² and David G. Aubrey²

¹College of William and Mary, School of Marine Science,
Virginia Institute of Marine Science, Gloucester Point, VA 23062-1346

²Woods Hole Oceanographic Institution
Woods Hole, Massachusetts 02543

January 1998

Technical Report

Funding was provided by the National Science Foundation
through Grant No. OCE91-02429.

Approved for public release; distribution unlimited.

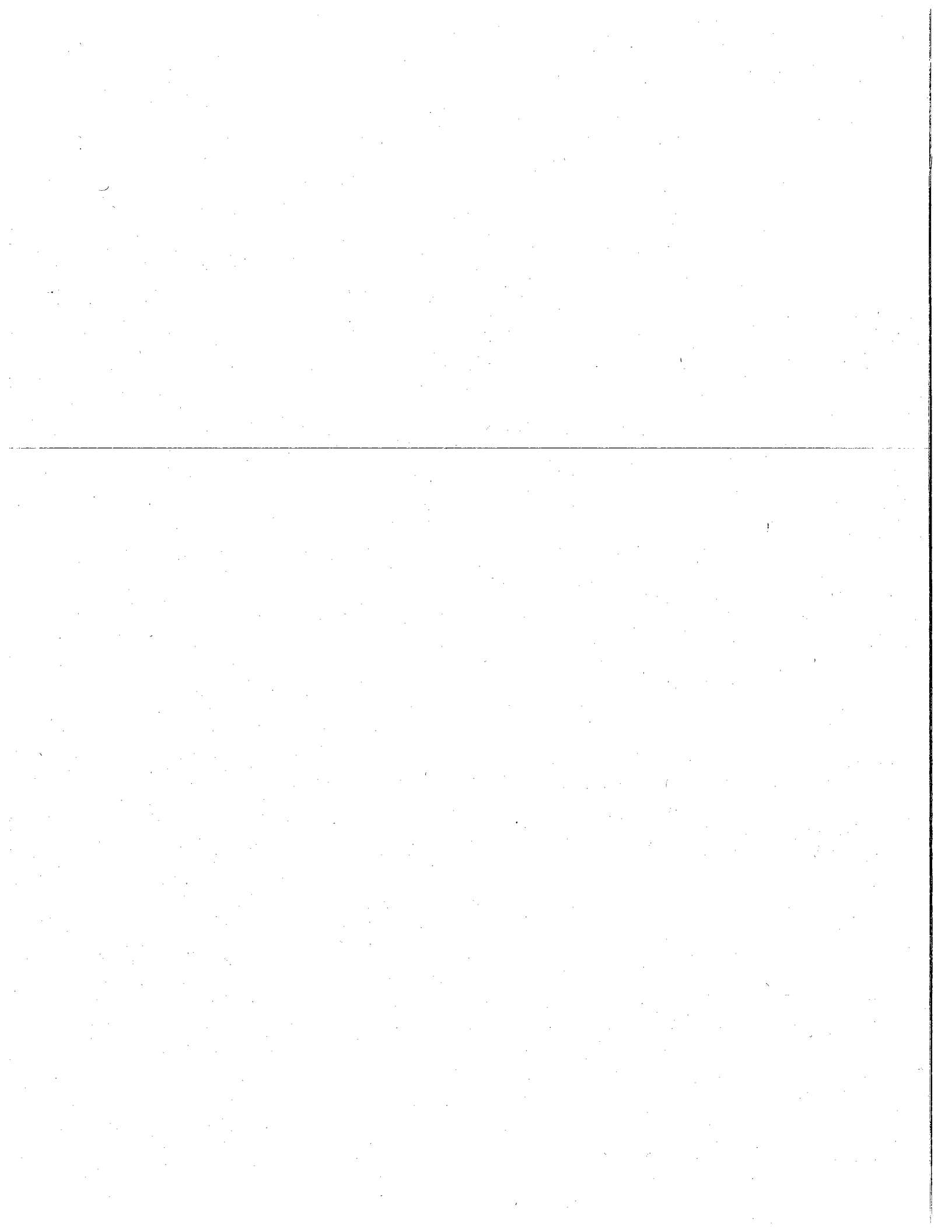

WHOI-98-02

**Pressure/Temperature Logger (PTL) Development and Field Deployment for the
Great Bay, NH, Tidal Dynamics Experiment**

by

Carl T. Friedrichs¹, Wayne D. Spencer² and David G. Aubrey²

¹College of William and Mary, School of Marine Science,
Virginia Institute of Marine Science, Gloucester Point, VA 23062-1346

²Woods Hole Oceanographic Institution
Woods Hole, Massachusetts 02543

January 1998

Technical Report

Funding was provided by the National Science Foundation
through Grant No. OCE91-02429.

Reproduction in whole or in part is permitted for any purpose of the United States
Government. This report should be cited as Woods Hole Oceanog. Inst. Tech. Rept.,
WHOI-98-02.

Approved for public release; distribution unlimited.

Approved for Distribution:



William B. Curry, Chair
Department of Geology and Geophysics



Abstract

During 1992 and 1993 experiments were conducted in the shallow east side of Great Bay, New Hampshire. These experiments were conducted to better understand the morphodynamics and evolutionary tendencies of shallow tidal embayments and intertidal flats. Hardware and software used in the collection of data are described. Discussed also are techniques used to collect data. Six pressure temperature loggers (PTL) and one current meter (TCSWG) were developed for the experiments. Both instruments are internally powered and internally recording. The instruments were developed because no company was found that manufactured a similar instrument within the price range of the project.

Table of Contents

	Abstract	i
1.	Introduction	1
	1.1. Motivation and goals	1
	1.2. Other related work	2
	1.3. Experiment overview	3
2.	Instrument Design	6
	2.1. Mechanical	6
	2.2. Electronic	7
	2.3. Power requirements	7
	2.4. Data Capacity	10
3.	Software	12
	3.1. Example session	12
4.	Calibration	14
	4.1. Method	14
	4.2. Offset	14
	4.3. Gain	14
5.	Summary	16
	5.1. Experiment results	16
	5.2. PTL	16
	Acknowledgements	17
	References	17

List of Tables

1.1	Great Bay field experiment instrument location	5
4.1	Pressure sensor calibrations	15
4.2	Estimates of PTL accuracy	15

List of Figures

1.1	Great Bay field location map	4
2.1	PTL pressure case	8
2.2	PTL electronics rack	9
2.3	Interface electronics for the PTL	11

1. Introduction

Pressure measurements required for the Great Bay, New Hampshire, experiment necessitated the construction of several small, programmable, inexpensive, accurate, and reliable) Pressure/Temperature Loggers (PTLs). The instruments were designed and built at WHOI because no adequately programmable instrument was commercially available to log tides, waves and temperature for the needed duration (one month) at a cost the project could bear (less than \$3,000 each). The typical price for an instrument of this type is \$5-10k. The project funded the construction of 5 PTLs which were deployed successfully at Great Bay for one month periods during the two experiments. This report describes (i) the design and calibration of the PTL, (ii) the deployment and resulting observations from Great Bay, and (iii) the motivation behind the experiment and other recently accomplished, closely related work.

1.1. Motivation and goals

The overall goal of the project funded by NSF grant OCE 91-02429, of which the Great Bay experiment is one component, is an improved understanding of the morphodynamics and evolutionary tendencies of shallow tidal embayments and intertidal flats. The strong tidal nonlinearities, poorly quantified role of wind waves, and the important interactions between hydrodynamics, sediment transport, and morphology have posed such difficult scientific questions in the past that the question of the evolution of these shallow coastal systems has not been resolved. The focus of the project is the temporal and spatial distribution of shear stress due to tidal circulation and episodic wind wave activity, and the consequences of this stress distribution for sediment transport and morphologic change. Questions being addressed include: (1) What is the dominant momentum balance governing tidal flow over representative intertidal flats? (2) Do tidal currents, wind waves, or an intermittent combination of both regimes dominate the bottom stress field? (3) Are spatial or temporal asymmetries in bottom stress more relevant to net sediment transport? (4) What "equilibrium" tidal flat morphologies (and embayment morphologies in general) are likely to develop from different bottom stress fields? (5) How does morphology feed back to affect hydrodynamics as equilibrium is approached? (6) Do observations indicate significant correlations between temporal/spatial variations in the wave/current climate and temporal/spatial variations in the tidal flat topography, bottom sediment properties, and/or suspended sediment concentration?

At present the hydrodynamic details of intertidal flow over flats is poorly understood. The large changes in water depth over flats has made the collection of accurate, continuous observations of currents and pressure gradients particularly difficult. The characteristically large changes in water depth have similarly impeded developments in our theoretical understanding of these flows. Yet the presence of intertidal flats along economically important coastal areas and waterways has required their representation in increasingly detailed numerical models of coastal fluid motion. One novel approach to the dynamical inclusion of intertidal flats in finite element models assumes the highly nonlinear momentum balance across the flats to be frictionally dominated, allowing the neglect of the instability-inducing acceleration terms from the momentum equation (Friedrichs et al., 1990, 1992b). This numerical approach is presently being extended by a group at the Thayer School of Engineering, Dartmouth College, led by D. R. Lynch (Ip, et al, submitted). A major motivation for this field experiment was to better constrain tidal flat hydrodynamics for application to these models, including clarification of the appropriate momentum balance.

1.2. Other related work

This report focuses on the observational aspects of this study. However, much theoretical work and syntheses of existing observations relevant to the morphodynamics of tidal embayments have also been completed under funding from the same National Science Foundation grant. Two theoretical aspects of tidal morphodynamics were studied in particular: (i) mechanisms responsible for temporal asymmetries in bottom stress during flood and ebb (Friedrichs and Madsen, 1992; Friedrichs, 1993; Friedrichs and Aubrey, 1994 a, b), and (ii) evolution toward morphologies which minimize spatial variations in bottom stress (Friedrichs, 1993, 1995; Friedrichs and Aubrey, 1992, 1994 a, b, 1996; Friedrichs et al., 1992a). Temporal asymmetries in bottom stress enhance transport of coarse sediment in the direction of flood- or ebb-dominance, and may either accelerate the tendency for estuarine in-filling (under flood-dominance) or perhaps lead to a stable balance between sediment supply and dispersal (under ebb-dominance). If critical stress at erosion and deposition are significantly different, as is typically the case for fine sediment in tidal channels and on tidal flats, then "diffusive" dispersion of fine sediment is likely. Spatial variations in bottom stress will then favor deposition in areas of lower relative to areas of higher stress.

The first topic is an analytic extension of 1-D numerical modeling experiments conducted by Speer and Aubrey (1985) and Friedrichs and Aubrey (1988). Through diagnostic numerical modeling and comparison of results to field observations, Speer and Aubrey (1985) and Friedrichs and Aubrey (1988) showed that embayments which are shallow relative to tidal amplitude tend to be flood-dominant, whereas embayments with deep channels and large tidal flats tend to be ebb-dominant. Friedrichs and Madsen (1992) and Friedrichs and Aubrey (1994b) showed analytically that the hydrodynamics of these systems in general, and their non-linear aspects in particular, can be more easily understood if one assumes the first-order momentum balance to be frictionally-dominated. Applying this simplification, Friedrichs and Madsen (1992) and Friedrichs and Aubrey (1994b) derived an "asymmetry parameter", γ , which governs when systems will be flood- or ebb-dominant. This parameter is given by $\gamma = \delta a/h - \Delta b/b$, where a is tidal amplitude, h is channel depth at mean water (excluding flats), b is embayment width at mean water (including flats), Δb is the amplitude of change in embayment width over the tidal cycle, and δ is a dimensionless number between about 1 (when acceleration is important) and 1.6 (when acceleration is unimportant). If $\gamma > 0$, systems tend to be flood-dominant; if $\gamma < 0$ they tend to be ebb-dominant.

The second theoretical topic is qualitatively consistent with the concepts of shear and settling lag developed by Postma (1967), where lags between hydrodynamics and sediment response cause sediment to move away from areas of high stress and toward areas of low stress. Friedrichs (1995) tested the applicability of this argument to channelized embayments by examining spring tidal discharge and cross-sectional geometry from 228 sections in 26 separate sheltered tidal systems. Friedrichs (1995) found the distribution of (tidally-induced) maximum bottom stress, τ , within individual systems to be statistically consistent with spatially uniform τ . The critical shear stress just capable of initiating sediment motion was found to provide a lower bound on τ , and the characteristic value of τ appropriate to individual systems was found to be a function of spring tidal range. Small along-channel deviations away from uniform τ were associated with along-channel variation in the direction of maximum discharge, suggesting a feedback mechanism between temporal and spatial asymmetries in τ . It was hypothesized that convergence in the direction of maximum shear stress (due to temporal asymmetries) causes deposition, a reduction in cross-sectional area, and an increase in velocity. Area is reduced and velocity

is increased until a locally increased magnitude of τ is reached which effectively disperses the sediment once more (via spatial asymmetries). This feedback between temporal and spatial asymmetries is consistent with the analytic results of Friedrichs and Aubrey (1994b), who also found a tendency for counteracting temporal and spatial asymmetries to be present in stable tidal channels.

Friedrichs and Aubrey (1996) applied similar concepts to the study of equilibrium tidal flat hypsometry, i.e., the distribution of horizontal surface area with respect to elevation. Recent observations of tidal flat morphology have correlated convex hypsometry with large tide ranges, long-term accretion and/or low energy wave activity. Concave hypsometry, in turn, has been correlated with small tide ranges, long-term erosion and/or high energy wave activity. Friedrichs and Aubrey (1996) demonstrated that this empirical variation in tidal flat hypsometry is consistent with a simple morphodynamic model which assumes tidal flats to be at equilibrium when t is spatially uniform. Two general cases were considered: (i) dominance of τ by tidal currents, where τ is equal to maximum tidally-generated shear stress, and (ii) dominance of τ by wind waves, where τ is equal to maximum wave-generated shear stress. Analytic solutions indicated that domination by tidal currents favors a convex hypsometry, and domination by wind waves favors a concave hypsometry. In addition to the roles played by tides and waves, the effect of shoreline curvature on equilibrium hypsometry was also found to be important.

1.3. Experiment overview

The observational portion of this project is focused on a large intertidal mud flat and channel system in Great Bay, NH (Figure 1.1). Great Bay was selected as the field site for several reasons. In particular: (1) Great Bay contains one of the largest expanses of sheltered, intertidal mud flats in the northeastern United States. Previous observational and modeling work (see Section 1.1) has indicated the importance of intertidal flats in determining flood- or ebb dominance of entire embayments. Previous field studies performed by our group at Woods Hole have focused primarily on tidal channels, including the Nauset Inlet system (Aubrey and Speer, 1985) and Chatham Harbor (Giese et al., 1989), and intertidal mud flats are an under-studied environment in comparison, especially with regards to hydrodynamics. (2) Background literature is available on the general hydrodynamic conditions and geologic history of the Great Bay estuary, compiled in large part by the faculty of the Jackson Estuarine Laboratory, University of New Hampshire. Recent, generalized bibliographies on Great Bay have been compiled by Penniman et al. (1989) and Short (1992). (3) Previous systems that have been studied in detail by our group (Nauset, Chatham) are flood-dominant, whereas historical observations indicate at least certain portions of Great Bay are ebb-dominant.

Table 1.1 and Figure 1.1 summarize the locations and durations of instrument deployments at Great Bay. Deployment locations are relative to the benchmark at the Emery Farm (157 Newington Rd, Greenland, NH) at $70^{\circ} 50.085'W$, $43^{\circ} 03.407' N$, with angles in degrees clockwise of true north. The PTLs formed the major component of the field experiment and are the primary focus of this report. Additional aspects of the Great Bay experiment will be documented in subsequent reports and papers. The PTL deployment scheme during the fall of 1992 was aimed at identifying general patterns in the tidal pressure gradient, and thus the PTLs were distributed widely over the flats. Having identified the orientation of the gradient in the first year, the second deployment in the summer of 1993 positioned all but one of the PTLs in a single line more closely spaced along the dominant pressure gradient. In both years the PTLs were deployed inside PVC pipe sunk into the tidal flat in an attempt to (i) minimize flow disturbance, and (ii) allow accurate documentation of tidal water levels all the way to tidal flat exposure.

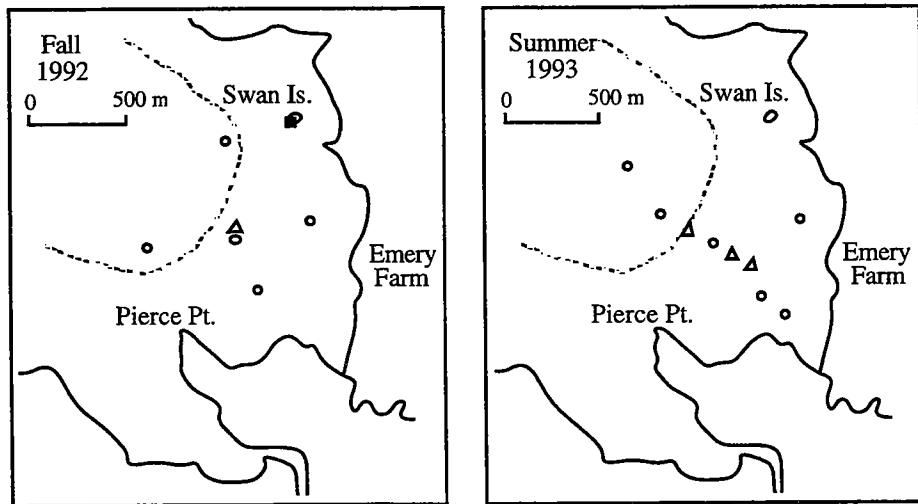
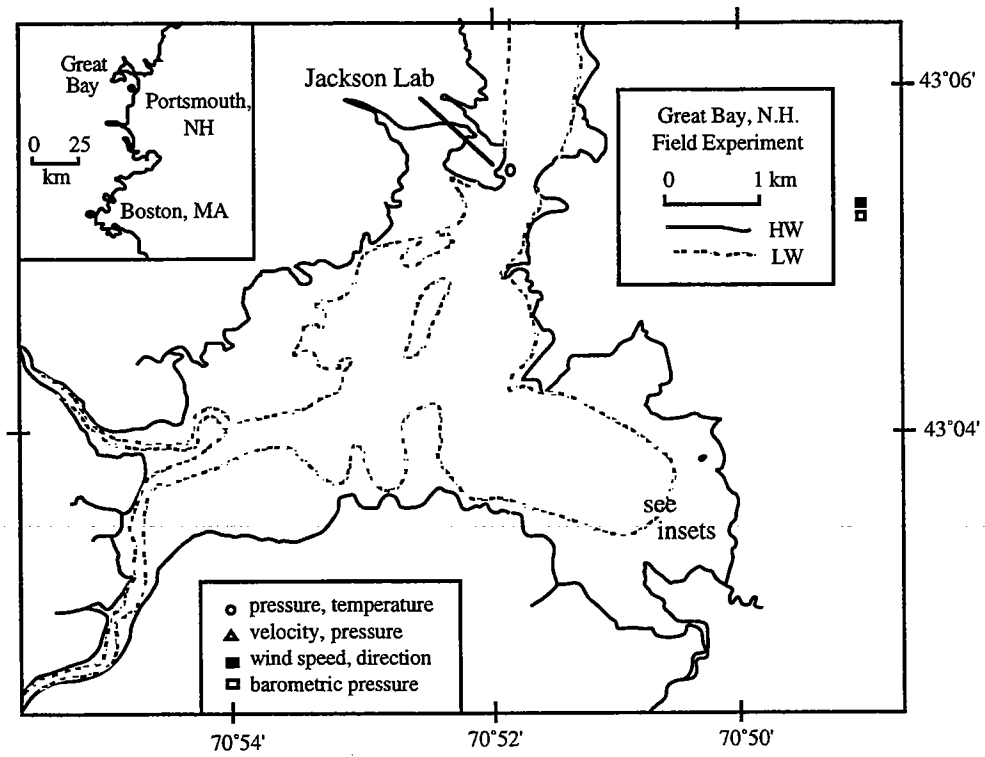

Figure 1.1. Great Bay field experiment location maps.

Table 1.1 Great Bay field experiment instrument locations						
Instrument	Deployment Date	Retrieval Date	Distance (m)	Angle (deg)	Sampling Scheme	Data Quality
PTL01	9/19/92	9/30/92	1167	274.3	6 min + 240 @ 4 Hz each hr	Good
	10/1/92	10/15/92	375	310.6	6 min + 240 @ 4 Hz each hr	Good
	8/10/93	8/17/93	955	283.6	6 min + 120 @ 4 Hz each hr	Good
	8/18/93	9/2/93	955	283.6	6 min + 120 @ 4 Hz each hr	Good
PTL03	9/25/92	9/30/92	696	281.8	6 min + 240 @ 4 Hz each hr	Poor
	10/1/92	10/17/92	996	312.2	6 min + 240 @ 4 Hz each hr	Poor
	8/11/93	8/26/93	285	317.8	6 min + 120 @ 4 Hz each hr	Good
	8/27/93	9/2/93	285	317.8	6 min + 120 @ 4 Hz each hr	Good
PTL04	9/20/92	9/30/92	375	310.6	6 min + 240 @ 4 Hz each hr	Good
	10/1/92	10/17/92	1167	274.3	6 min + 240 @ 4 Hz each hr	Good
	8/10/93	8/26/93	432	243.1	6 min + 120 @ 4 Hz each hr	Good
	8/27/93	9/2/93	432	243.1	6 min + 120 @ 4 Hz each hr	Good
PTL05	9/20/92	9/30/92	592	255.7	6 min + 240 @ 4 Hz each hr	Good
	10/1/92	10/17/92	592	255.7	6 min + 240 @ 4 Hz each hr	Good
	8/10/93	8/26/93	396	220.0	6 min + 120 @ 4 Hz each hr	Good
	8/27/93	9/2/93	396	220.0	6 min + 120 @ 4 Hz each hr	Good
PTL06	9/20/92	9/30/92	996	312.2	6 min + 240 @ 4 Hz each hr	Good
	10/1/92	10/13/92	696	281.8	6 min + 240 @ 4 Hz each hr	Good
	8/10/93	8/26/93	659	277.1	6 min + 120 @ 4 Hz each hr	Good
	8/27/93	9/2/93	659	277.1	6 min + 120 @ 4 Hz each hr	Good
TCSWG	8/11/93	8/17/93	1219	293.9	120 @ 4 Hz each 6 min	No data
	8/18/93	8/19/93	768	281.7	120 @ 4 Hz each 6 min	Good
	8/20/93	8/22/93	768	281.7	120 @ 4 Hz each 6 min	No data
	8/23/93	8/26/93	545	271.5	120 @ 4 Hz each 6 min	Good
	8/27/93	9/7/93	1219	293.9	120 @ 4 Hz each 6 min	No data
635-9	9/20/92	10/13/92	695	281.8	256 @ 2 Hz each 30 min	Good
	8/10/93	9/2/93	435	265.3	256 @ 2 Hz each 30 min	Good
TDR516	8/11/93	9/2/93	1219	293.9	6 min interval	Good
TDR515	9/20/92	10/16/92	Jackson Lab pier		6 min interval	Good
	8/10/93	9/2/93	Jackson Lab pier		6 min interval	Good
Anemometer	9/21/92	10/16/92	Swan Island		1 min interval	Poor
Angle of Pierce Pt east of due north:				249.0		

2. Instrument Design

Pressure measurements required for the Great Bay experiment necessitated the construction of several small, programmable, inexpensive (but accurate and reliable) Pressure and Temperature Loggers (PTLs). The PTLs had to be small enough to fit inside wells sunk into the flats at Great Bay, yet have power and data storage capacity sufficient to record detailed wave and tide information internally for periods up to a month. Temperature measurements, although not used for the New Hampshire project, were included in the PTL's capability to accommodate other future requirements. A YSI thermister was used as the sensor and read via a voltage divider (Figure 2.3). The center voltage of the voltage divider inputs directly to one of the analog channels of the Tattle Tale data logger.

2.1. Mechanical

Due to the specifications that the PTL be used in shallow water it was feasible to construct the case of polyvynelchloride (PVC). PVC was chosen for its low cost, chemical compatibility with seawater, and its ease of machining. PVC and 316 Stainless Steel (SS) are the only materials exposed to the marine environment. The case (Figure 2.1) is 17 inches (43 cm) in length (including the 0.63 inch (1.6 cm) lid). The handle adds about two inches to the length of the case. All but one of the PTLs have an external diameter of 5.0 inches (12.7 cm), and an internal diameter of 3.6 inches (9.2 cm). The exception is PTL # 06, which was a prototype, and has an O.D. of 5.6 inches (14.2 cm) and an ID of 4.1 inches (10.5 cm). The water seal design of the case (Figure 2.1) consists of simple o-ring seals, 1/4 inch pipe threads, and 1/4 inch screws for end cap fasteners. One end of the case is permanently closed with a welded and glued end cap. Pressure changes at the diaphragm of the pressure sensor are recorded on an internal data logger. The diaphragm is located approximate 23/8 inches (6.03 cm) below the external surface of the removable lid. The distance from the lid to the pressure sensor diaphragm can be obtained by measuring from the weld ring on the pressure sensor that is closest to the lid.

The maximum deployment depth for the PTL during the NH experiment was 4 m. The PTL pressure case is rated to a depth of 100 m, but deployment is limited to 17 m by the pressure rating of the Druck pressure sensor and the pipe fittings used as case penetrators. The response of the Druck pressure sensor is linear and accurate up to a pressure of 40 psi (400% of rated pressure). Deployment at these depths require a change in the resistors used to control the amplifier circuit gain and offset. A conservative 13 m maximum depth specification for the PTL, with the existing pressure sensor, would allow for occasional deeper water deployments (outside the shallow tidal systems in which the PTL was designed to be used). This specification would allow for 4 m water surface waves to be superimposed on the deployment depth. Deployments deeper than 13 m would require a redesign of all penetrators and the use of a pressure sensor rated for a greater depth.

The electronics rack inside the pressure case (Figure 2.2) is made of non-conducting materials. All penetrations are through one end cap to which the electronics rack is attached. This design allows the user to open the case and remove all electronic parts from one end. Fewer o-ring seals are needed reducing fabrication time and the likelihood of water leaks. Both sensors penetrate the end cap using 1/4" National Pipe Thread (NPT). These threads are used in low pressure pipe systems such as domestic water piping where the pressure is typically 80 psi or less. For low pressure oceanographic applications these fittings provide a low cost, highly reliable solution to water proof penetration needs.

2.2. Electronic

The PTL major electronic components consist of a strain gauge pressure sensor, a thermistor encapsulated inside a 1/4" NPT stainless steel pipe plug, a digital data logger (Onset Computer, Tattletale model 2b), an interface board (designed and fabricated at WHOI), and a battery pack. Temperature is measured using a thermistor and resistor to create a voltage divider circuit. The system's Tattletale data logger, which requires very little power (5 ma in sleep mode, 30 ma in run mode) has a 229 kB data capacity RAM storage. At Great Bay the maximum deployment time of the PTL was defined by the data storage capacity rather than by the power capacity of the battery pack. Using a sampling scheme that records one tide record every 6 minutes and 120 wave observations every hour (4 Hz for 30 seconds). The memory is filled in about 30 days. Sampling can be adjusted to fit the user's needs.

The interface electronics board (Figure 2.3) consists of a differential, chopper-stabilized amplifier (Linear Technologies part #LTC1052) with a capacitor switching differential input (LTC part #1043) with + or - offset adjustment capabilities. Using about 1 ma powered from the Tattletale voltage regulator, the amplifier has a gain of about 100. The output of the amplifier is limited to less than 5 volts because the amplifier is excited by the output of the data logger's onboard 5 volt regulator. Limiting the amplifier output to less than 5 volts is important because the data logger's analog to digital (A to D) converter will fail with an input higher than 5 volts. A component carrier is used to mount appropriate gain and offset controlling resistors. If the PTL is to be deployed at a different depth the gain and offset can be changed to optimize resolution. The resistors that affect the gain and offset are easily changed because they are mounted on a component carrier.

The pressure sensors in the PTLs are Druck model PDCR 961. This pressure sensor has a manufacturer's specified accuracy of about 0.68 cm of seawater (sw). Careful calibration at WHOI, however, indicate significantly better results are possible (see Section 4). Pressure measurements are made ratiometrically using the regulated 5 volt DC supplied from the Tattletale (ratiometric because this voltage is also the A to D reference voltage). The amplifier drives to within 0.02 volts of the 5 volt supply giving a digital dynamic range of 0 to 4084 out from the A to D converter. The digital range of 4084 translates to a resolution of about 0.1 cm sw over the 4 m depth range used at Great Bay. The 4 m depth range specification for Great Bay was to accommodate the 2.5 m maximum spring tidal range, 0.5 m burial into the mud flat, potential air pressure fluctuations equivalent to 35 cm, plus a few tens of cm to spare.

2.3. Power requirements

The battery pack consists of two 6 volt alkaline lantern batteries. The battery used at Great Bay (Duracell part #PC915) has approximately 11 amp hours capacity if a cut off voltage of 3.5 and a temperature of 21 degrees C is assumed. Choosing a typical temperature of 12 degrees C and reducing the capacity of the battery to approximately 80% (this is a conservative specification because specifications from Duracell indicate that at 12 degree C the amp hour capacity is reduced to only 90%), the two batteries supply 8.8 amp hours. The sampling scheme at Great Bay was (i) bursts of 0.5 second samples averaged for one minute starting every six minutes (to resolve tide), and (ii) bursts of 0.25 second samples of unaveraged pressure for a duration of 30 seconds starting every hour (120 records recorded to resolve waves).

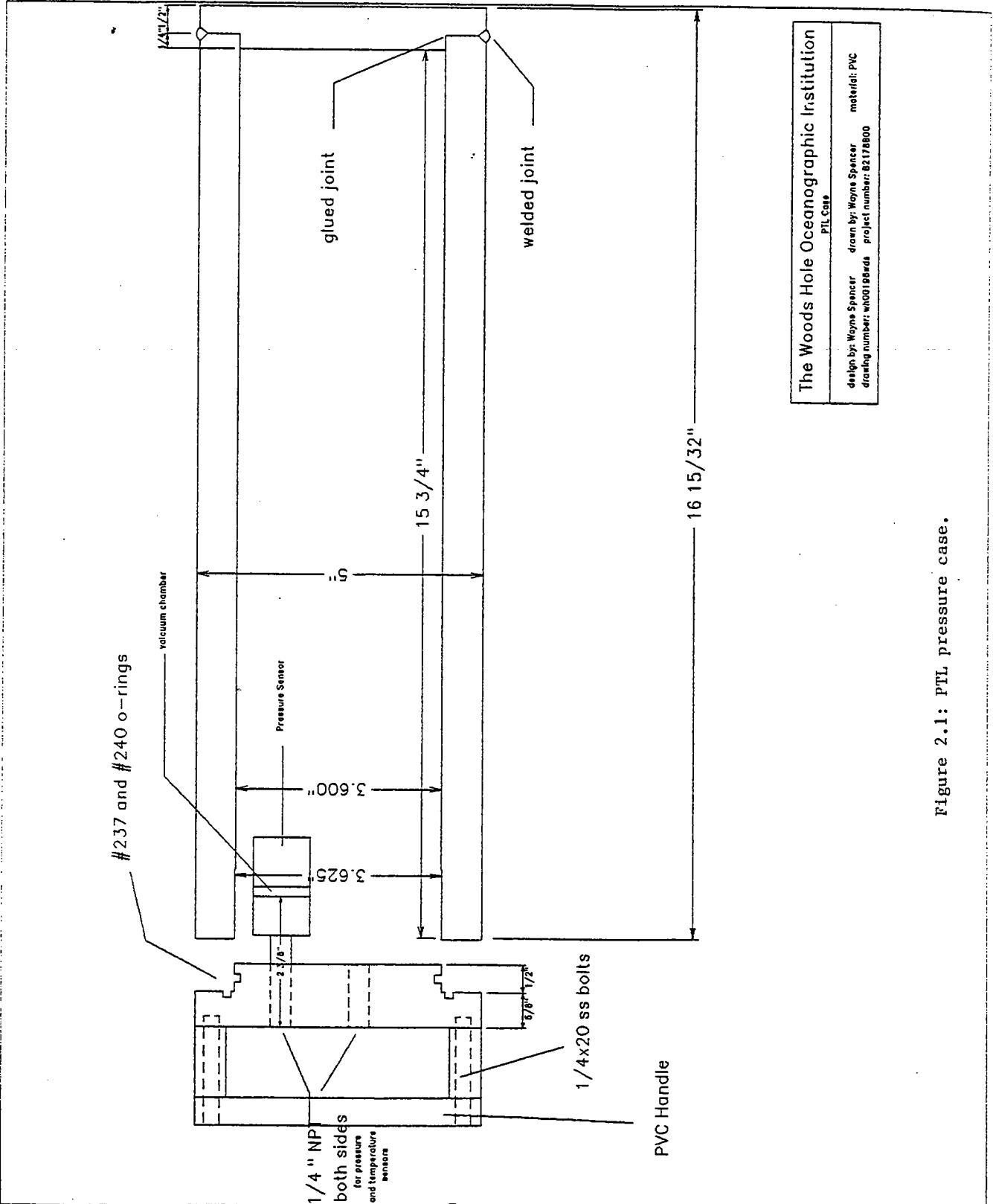

The Woods Hole Oceanographic Institution
 PTL Case
 design by: Wayne Spencer drawn by: Wayne Spencer material: PVC
 drawing number: wh001984ds project number: 82178600

Figure 2.1: PTL pressure case.

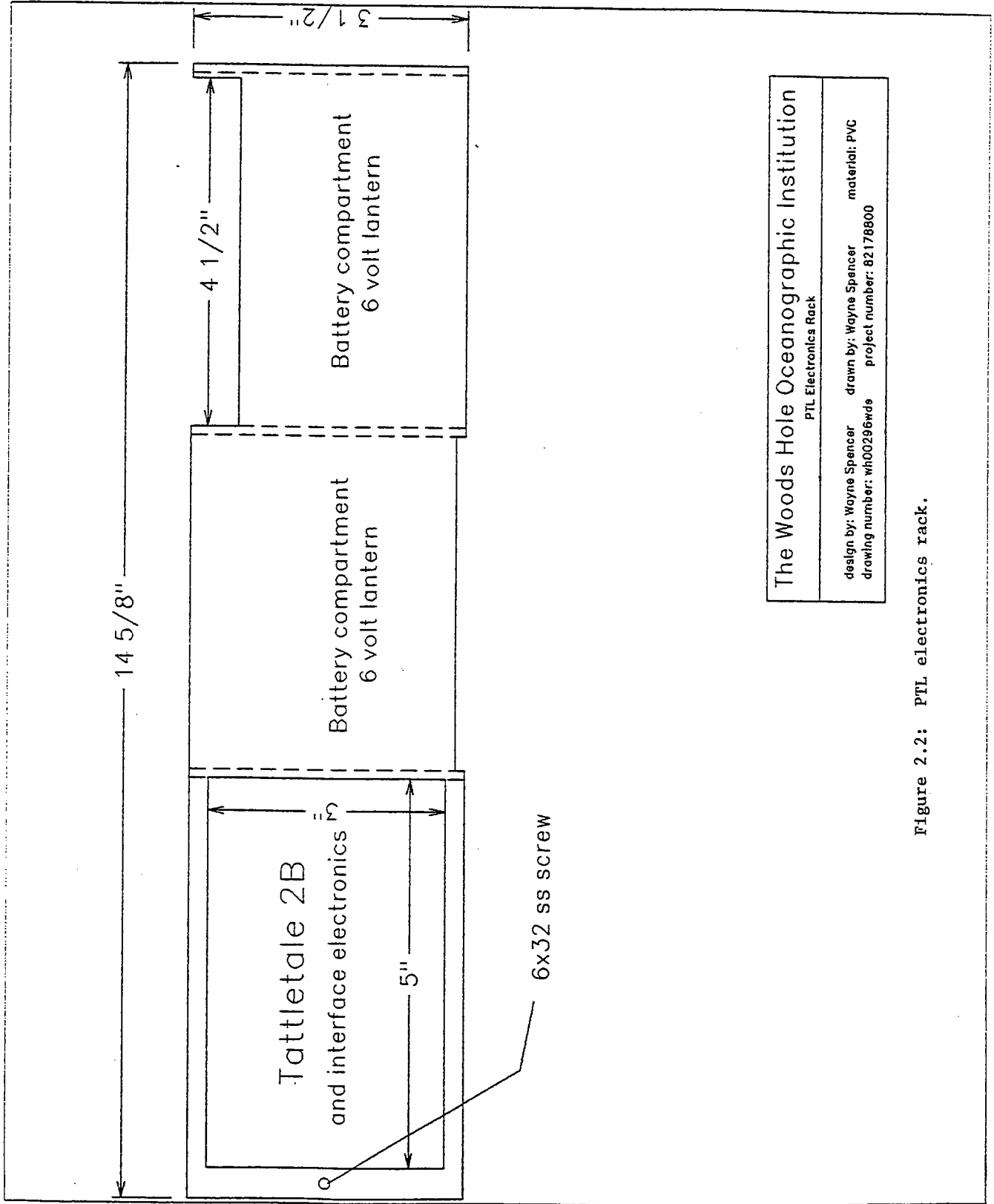

The Woods Hole Oceanographic Institution
 PTL Electronics Rack
 design by: Wayne Spencer drawn by: Wayne Spencer material: PVC
 drawing number: wh00296wds project number: 82178800

Figure 2.2: PTL electronics rack.

The following battery capacity requirement is derived assuming that the system runs for 1.1 minutes every 6 minutes (for tide measurement and Tattletale warm-up) plus an additional 36 second recording event every hour for wave measurements.

- | | | | |
|----|--|-------------|---------------|
| 1. | 32 ma for 11.6 min/hr for running Tattletale | 4.45 amp hr | (for 30 days) |
| 2. | 5 ma for 48.4 min/hr for sleeping Tattletale | 2.9 amp hr | (for 30 days) |

The total power requirement of 7.4 amp hours is significantly less than the available 8.8 amp hours, and the PTL could be programmed to sample less frequently and remain deployed longer. Nonetheless, it is generally suggested that easily accessible shallow water deployments be limited to 30 days as many factors such as fouling and damage due to boat traffic can jeopardize data.

Using the Eveready 6 volt lantern battery #528 will increase the power capacity significantly. The specifications for the 528 indicate that at similar discharge rates to that of the Great Bay deployment scheme the 528 will provide about 16 ampere hours at 12 ° C. This would mean a deployment length (if additional memory was used) of about 65 days.

2.4 Data capacity

The data storage requirement for one data word is 2 bytes. For each 6 minute data sample (pressure, temperature, date, and time) the data storage requirement is 8 bytes. This implies 80 bytes/hr, or 1920 bytes/day, or 57,600 bytes/30 days. The hourly component will use 240 bytes/hour plus 4 bytes for date and time which will use 5,856 bytes/day, or 175,680 bytes/30 days. This would require a data storage capacity of 233,280 bytes to make the above deployment. The data storage capacity of 229,000 will be expended in 29.45 days using the above sampling technique. The following is a breakdown of a sequence of data words used in recording tide and waves. The TT is a sequential recorder (1 dimension array). The smallest amount of memory that the PTL can record is one Byte.

```

Beginning of data file year (1B), Month(1B), Day(1B)
Tide P (2B), T(2B), Day(1B), Hour(1B), Minute(1B), second(1B)
      P (2B), T(2B), Day(1B), Hour(1B), Minute(1B), second(1B)
      P (2B), T(2B), Day(1B), Hour(1B), Minute(1B), second(1B)
      P (2B), T(2B), Day(1B), Hour(1B), Minute(1B), second(1B)
      P (2B), T(2B), Day(1B), Hour(1B), Minute(1B), second(1B)
      P (2B), T(2B), Day(1B), Hour(1B), Minute(1B), second(1B)
      .
      .
      .
Waves Day(1B), Hour(1B), Minute(1B), Second(1B)
      P (2B)
      P (2B)
      P (2B)
      P (2B)
      P (2B)
      .
      .
      .
      P (2B)

```

Note that the user's option allows the selection of no wave samples as well as tide interval in which case the above data stream would be changed.

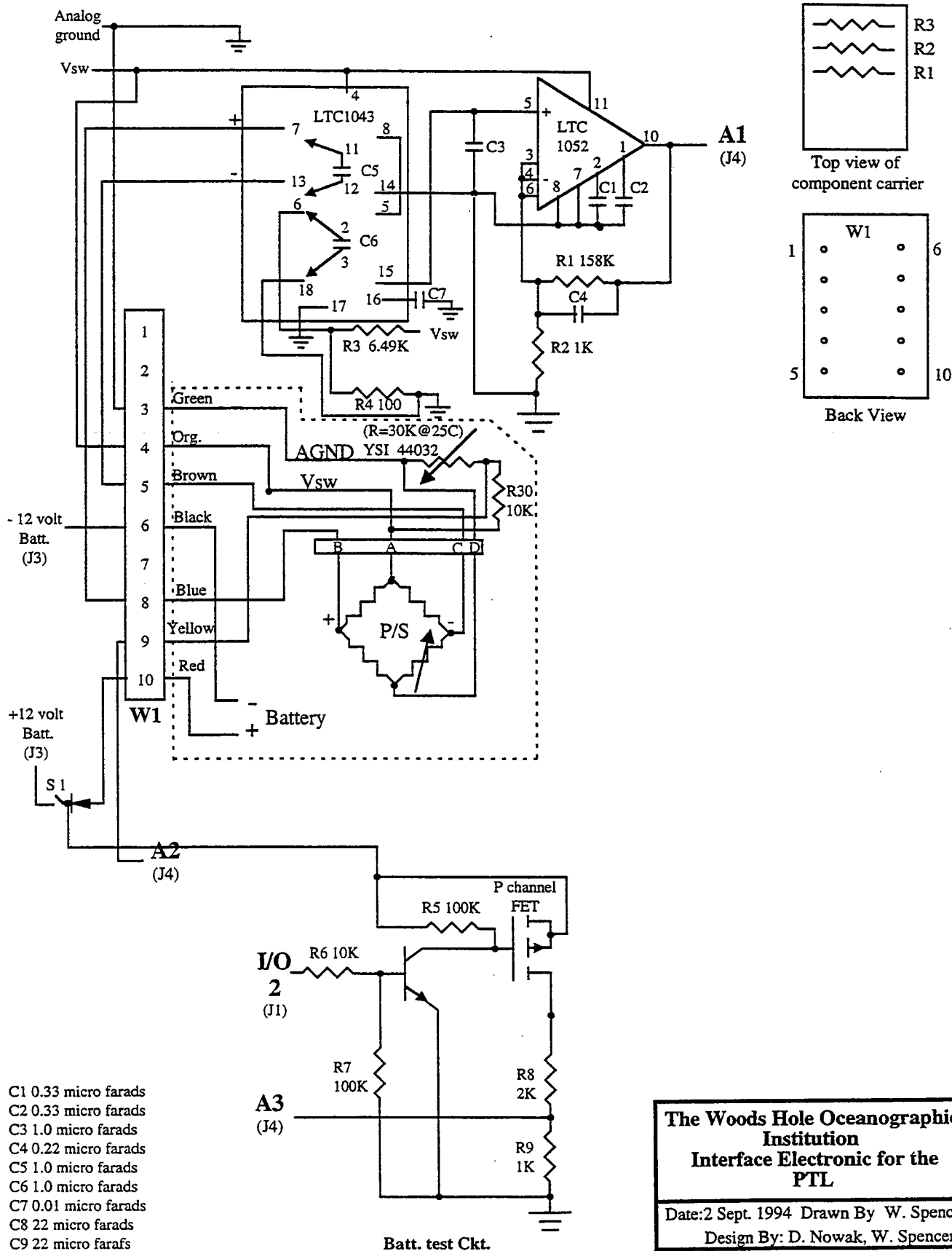

Figure 2.3: Interface electronics for the PTL.

3. Software

Software requirements for the PTL were (i) sample and store data accurately and efficiently, (ii) assist the user in mistake free instrument set up (including reminders and logical entry protocol), (iii) allow the user to dump data quickly in a format compatible with existing software, (iv) allow the user to define different sampling schemes easily. The Tattletale data logger, which is easily programmed in BASIC computer language, is ideally suited for this task.

The PTL program gives the user menu-options for setting up data acquisition schemes and other functions. All program functions take place while the PTL is running on its batteries and connected to a terminal emulator. It is recommended that an emulator produced by Onset Computer (TattleTools) be used when setting up the PTL. This allows convenient reloading of the software after switching power on. For the Great Bay project TattleTools v.1.33 for the Macintosh was used. Onset also provides Windows 3.1 based software. The loaded software is lost in the event of a disconnection with the alkaline lantern batteries, but any data in the RAM are preserved as long as the Tattletale's lithium backup battery is functional. Disconnecting the lantern batteries is a practical way to "reboot" the PTL, keeping in mind one must reload the PTL software afterward. The software downloads data from the PTL by dumping it to a computer screen so it is practical to use a communication program that easily saves a screen dump when downloading. The user should ensure that handshaking is enabled on the TT 2B before starting the dump routine. The Tattletools command **Xshake 1500** enables handshaking with a time-out of 15 seconds.

3.1. Example session

>RUN

PTL FIELD PROGRAM VERSION 4.1

C. FRIEDRICHS, W. SPENCER, T. McSherry SEPT 11, 1992

LAST UPDATED AUG. 5 1993

(NOTE: REPLACE LITHIUM EVERREADY #CR2032 BY JULY 1998)

PTL BATTERY VOLTAGE UNDER NORMAL LOAD = 2861 CPU units (see calibration)

!! ACCOUNT FOR TEMPERATURE WHEN CALCULATING DEPLOYMENT LIFE !!

ENTER PTL ID NUMBER (1,3,4,5 OR 6): 1

PTL TIME IS NOW 0:0::36 ON 1/1/80

DO YOU WANT TO SET TIME & DATE? (0=NO, 1=YES): 1

YOU WILL ENTER YEAR, MONTH, DAY, HOUR, MINUTE AND SECOND, ONE AT A TIME. THE EXACT TIME WILL BE REGISTERED WHEN YOU HIT RETURN AFTER ENTERING THE SECOND.

THE YEAR IS (0 TO 99) 97

THE MONTH IS (1 TO 12) 11

THE DAY IS (1 TO 31) 5

THE HOUR IS (0 TO 23) 11

THE MINUTE IS (0 TO 59) 24

THE SECOND IS (0 TO 59) 40

NEW PTL TIME IS NOW 11:24::40 ON 11/5/97

IS NEW PTL TIME OK? (0=NO, 1=YES): 1

MENU: OPTION	ENTER
SCREEN TEST PTL	1
SET UP FOR TIDE OR TIDE & WAVE	2
CALIBRATE PTL	3
DUMP DATA FROM PTL	4
EXIT	5

MENU OPTION: 2

TIDE SAMPLING SCHEME:

PRESSURE IS SAMPLED EVERY 0.5 SEC DURING A BURST.

THE AVERAGE PRESSURE SAMPLE DURING THE BURST IS THEN RECORDED TO THE DATAFILE AS A TIDE READING.

IF YOU MAKE A MISTAKE, TYPE <CTRL> C AND BEGIN AGAIN

ENTER INTERVAL BETWEEN BEGINNING OF TIDE BURSTS IN MINUTES (6 IS SUGGESTED, MUST BE MULTIPLE OF 2): 6

ENTER NUMBER OF PRESSURE SAMPLES PER TIDE BURST (120 IS SUGGESTED, 180 MAX): 120

ENTER TOTAL LENGTH OF DEPLOYMENT IN HOURS: 720

DO YOU WANT TO LOG WAVES? (0=NO, 1=YES): 0

PTL TIME IS NOW 11:25::28 ON 11/5/97

ENTER DATE AND TIME FOR FIRST TIDE OBSERVATION:

MONTH WILL BE (1 TO 12) 11

DAY WILL BE (1 TO 31) 7

HOUR WILL BE (0 TO 24) 12

MINUTE WILL BE (0 TO 59) 00

SECOND WILL BE (0 TO 59) 00

!! SELECT AND SAVE INFORMATION BETWEEN STARS !!

SET-UP INFORMATION FOR PTL NO. 1

1ST RECORD CENTERED AT 12:0::0 + 3 SECONDS, ON 11/7/97

TIDE BURST INTERVAL = 6 MINUTES

SAMPLES PER BURST = 120

LENGTH OF DEPLOYMENT = 720 HOURS

WAVES (0=NO, 1=YES) = 0

BYTES USED WILL BE = 57603 OUT OF POSSIBLE 224000

4. Calibration

4.1. Method

Because of the very small pressure differences to be resolved at Great Bay, a large effort was expended in accurately calibrating the PTL pressure sensors. Calibration of the PTLs was performed in an open stairwell at WHOI which allowed a five meter plastic tube to be hung vertically with several PTLs attached at the base via hose fittings. The tube was filled with fresh water and the water level was adjusted relative to a cloth measuring tape attached to the hose. The measuring tape was graduated in meters. The height of the water column adjacent to the measuring tape was observed by eye and recorded in a lab notebook while the PTLs recorded internally at 1 Hz. The height of the water column was adjusted every one to two minutes, and the response of each PTL was later averaged over each time interval (after the water level had stabilized) to produce a single record corresponding to each height. The barometric pressure in the standards lab in another part of the building was also recorded periodically to at least partially correct for the effects of variable atmospheric pressure. Some results of the PTL calibrations are displayed in Table 4.1.

4.2. Offset

Calibration offset information was not particularly useful at the Great Bay field experiment because precise elevation bench marks could not be established. Nonetheless, intercept information (probably accurate to ± 5 to 10 mm) is listed in Table 4.1 for the 1993 calibrations. This information may be useful in interpreting future PTL deployments. Applying the gain and intercepts in Table 4.1 to future PTL deployments will provide a first estimate of the equivalent column of fresh water above the sensor, i.e., one estimate of gauge pressure not including atmospheric pressure. The resulting total height represents the distance from the pressure sensor diaphragm, about 2.3/8" (6.03 cm) below the outer surface of the endcap, to the top of the water column. It is important to note the strong dependence of the intercept on the atmospheric pressure during calibration, thus mean atmospheric pressure during calibration is included in Table 4.1. A one millibar change in atmospheric pressure is equivalent to 10.2 mm of H₂O, and if applied elsewhere, the intercepts in Table 4.1 must be adjusted appropriately to match the local atmospheric pressure. In interpreting PTL field data it must be remembered that the PTL records total pressure, including atmospheric pressure (i.e., not gauge pressure). To interpret field data in terms of subtle local changes in sea level, barometric effects must be removed by subtracting out a record of atmospheric pressure recorded nearby, which often includes pressure variations equivalent to about 30 cm of fresh water. Correction for barometric pressure is not necessary, however, when calculating the pressure gradient between two PTLs deployed simultaneously within a few kilometers of each other. It is safe to assume the spatial variations in barometric pressure are on the order of 10s to 100s of km, so that the difference in pressure between two nearby PTLs will not include barometric effects.

4.3 Gain

At Great Bay resolution of relative head differences between instruments on the order of a few millimeters was desired. Since the tidal range at Great Bay is about two meters, gains must remain stable within a few parts per thousand over the period of a three-week deployment. The results displayed in Table 4.1 suggest that the PTLs are capable of this degree of accuracy. Exceptions are PTL03 in 1992, which was not properly adjusted for high resolution sampling until the second deployment, and PTL06 in 1993, which malfunctioned between the two experiments and apparently remained unstable after being rebuilt. Otherwise, apparent drifts in gain over a given deployment are probably due in large part to the errors inherent in (i) visual estimation of water height during the calibration

Table 4.1 Pressure sensor calibrations

PTL	Date	Temp (C)	Gain (mm H2O/bit)	R-square	# obs.	Range	Intercept	Atmos. Pres. (mbar)
PTL01	9/15/92	4	1.29935	0.9999370	15	672 - 3866		
	9/15/92	19	1.29691	0.9999924	16	807 - 3904		
	9/15/92	28	1.29726	0.9999898	16	853 - 3834		
	10/27/92	r.t.	1.29175	0.9999938	16	955 - 3841		
	7/22/93	r.t.	1.29891	0.9999872	31	816 - 3997	-706	1010.0
	9/14/93	r.t.	1.29824	0.9999974	20	961 - 3916	-843	1022.6
PTL03	10/27/92	r.t.	14.61	0.9910	18	76 - 397		
	7/22/93	r.t.	31.18	0.9947	31	73 - 209	-1822	1010.0
	8/3/93	r.t.	1.29944	0.9999982	19	118 - 3879	250	1014.3
	9/14/93	r.t.	1.29545	0.9999987	23	183 - 3809	171	1022.6
PTL04	9/17/92	r.t.	1.30495	0.9999934	13	508 - 3476		
	10/27/92	r.t.	1.29947	0.9999976	18	481 - 4043		
	7/22/93	r.t.	1.30612	0.9999937	31	319 - 3495	-62	1010.0
	8/3/93	r.t.	1.30642	0.9999985	18	401 - 3837	-114	1014.3
	9/14/93	r.t.	1.30134	0.9999966	23	457 - 4070	-184	1022.6
PTL05	9/15/92	4	1.29953	0.9999559	15	630 - 3823		
	9/15/92	19	1.29624	0.9999975	16	762 - 3858		
	9/15/92	28	1.29699	0.9999947	16	797 - 3777		
	12/14/92	r.t.	1.30134	0.9999643	13	880 - 3554		
	7/22/93	r.t.	1.30051	0.9999956	31	662 - 3851	-507	1010.0
	9/14/93	r.t.	1.30105	0.9999977	21	811 - 4023	-650	1022.6
PTL06	9/17/92	r.t.	1.29949	0.9999930	16	552 - 3882		
	12/14/92	r.t.	1.29081	0.9999584	12	579 - 3276		
	8/3/93	r.t.	1.24697	0.9999832	18	308 - 3902	13	1014.3
	9/14/93	r.t.	1.22812	0.9999990	21	403 - 3804	-90	1022.6

r.t. = room temperature

Table 4.2 Estimates of PTL accuracy

PTL	Experiment	Gain	error
PTL01	Fall 92	1.29480	0.00304
	Summer 93	1.29858	0.00034
PTL03	Summer 93	1.29744	0.00200
PTL04	Fall 92	1.30221	0.00274
	Summer 93	1.30380	0.00246
PTL05	Fall 92	1.29946	0.00187
	Summer 93	1.30078	0.00027
PTL06	Fall 92	1.29515	0.00434
Mean error:			0.00213

procedure and (ii) in correcting for changes in barometric pressure during the calibration process. For example, the r-squared values for calibrations on 12/14/92 and for the 4 degree calibration on 9/15/92 are consistently lower than the r-squared values for the 19 and 28 degree calibrations on 9/15/92, regardless of the individual PTL examined. Also the gains measured for PTL01 and PTL05 on 9/15/92 shift in unison between calibrations, but not monotonically with temperature. Since a single set of height readings are used for all PTLs during a given calibration run, inaccurate visual readings of water elevations or imperfect corrections for atmospheric pressure could produce such systematic variations. The smallest pre- to post-experiment drift in gain (for PTL05 between 7/22/93 and 9/14/93) is associated with very high r-squared values, further suggesting that stability in gain is largely a function of calibration errors.

Table 4.2 displays the gains used in processing the field data along with an estimate of the likely error in the gain. The gain used for each analysis is the mean of the gain measured before and after the experiment. The error is the difference between the mean gain and the pre-experiment gain. (The 1992 data from PTL03 and the 1993 data from PTL06 were not accurate enough for application to pressure gradient calculations.) Table 4.2 indicates that the "error" in gain was generally less for the second experiment than the first, which is consistent with a reduction in human error during calibration with practice. As discussed in the previous paragraph, the apparent drift in gain is probably an overestimate of the true drift because of inaccuracies in visually recording the water column height and accounting for changing barometric pressure. It is likely that the true limitation of PTL accuracy is closer to the lowest calibration errors in Table 4.2., i.e., less than one part in a thousand. To be conservative, however, the error in gain for the purposes of field data analysis was assumed to be the average of the errors listed in Table 4.2, i.e., about two parts per thousand.

5. Summary

5.1 Experiment results

For 3 weeks each in September '92 and August '93, an array of five to six pressure sensors were installed over 1 km² of intertidal flats, along with 1 electromagnetic current meter (EMCM) in '92 and 4 EMCMs in '93. This provided background hydrodynamic information while bottom topography (relative to rods inserted into the mud) and sediment were repeatedly sampled over the flat. Topographic changes suggest sediment do indeed continually disperse from areas of high bottom stress toward areas of low bottom stress. During calm periods, shear stress is greater in channels due to tidal velocities, and sediment moves from the channels to the flats. During wind events, stress is greater on the flats due to wind waves, and sediment moves back to the channels. Neither of these conditions is sustained for sufficient periods for the flat to reach "equilibrium" with a single dominant process. Rather, it appears the flat is always in "disequilibrium", continually adjusting toward, but never reaching, either wave-dominated or tidally-dominated morphologies.

5.2 PTL

The 5 PTLs (PTL 2 was not fabricated) used during the Great Bay project proved to be accurate and reliable. The exception was PTL 6 which suffered from a fabrication problem. The PTLs have a specified accuracy of .8 cm of sw. The accuracy of the gain was noted to be better (0.2 cm) than the specified accuracy. The resolution of the PTL can be adjusted to less than 0.0001 m. The drift in pressure data was noted to be less than 0.2 cm over a 3 week deployment. During the Great Bay experiments the temperature data from the PTLs were not used. The PTLs record temperature to an accuracy of 0.1^o C.

Acknowledgments

This work was funded by the National Science Foundation under grant number OCE91-02429. We would like to gratefully acknowledge the help of the personnel at the University of New Hampshire (UNH) for allowing us access to boat launching facilities at Jackson Estuarine Laboratory and for their many helpful insights and local knowledge about Great Bay. David Aubrey guided and aided us in the planning and execution of this project as well as in the procurement of funds. Steve O'Malley, Linda Lotto, and Ben Gutierrez were the major players with the authors in doing the field work. Larry Ward of UNH provided not only local knowledge but many helpful hours of his time to the project. Preparation of this report was facilitated with the help of Ms. Pamela Barrows of WHOI.

References

- Aubrey, D. G., and P. E. Speer, 1985. A study of non-linear tidal propagation in shallow inlet/estuarine systems, part I: observations. *Estuarine, Coastal and Shelf Science*, 21: 185-205.
- Friedrichs, C. T., 1993. Hydrodynamics and morphodynamics of shallow tidal channels and intertidal flats. Ph.D. Thesis, Woods Hole Oceanographic Institution - Massachusetts Institute of Technology Joint Program in Oceanography, Woods Hole, MA, 214 pp.
- Friedrichs, C. T., 1995. Stability shear stress and equilibrium cross-sectional geometry of sheltered tidal channels. *Journal of Coastal Research*, 11:1062-1074.
- Friedrichs, C. T., and D.G. Aubrey, 1988. Non-linear tidal distortion in shallow well-mixed estuaries: a synthesis. *Estuarine Coastal and Shelf Science*, 27: 521-545.
- Friedrichs, C. T., and D. G. Aubrey, 1992. Equilibrium hypsometry of intertidal flats. Proceedings, Physics of Estuaries and Coastal Seas, 6th International Conf., Margaret River, Australia.
- Friedrichs, C.T., and D.G. Aubrey, 1994a. Tidal propagation in strongly convergent channels. *EOS*, 75 (No.3, supplement): 62.
- Friedrichs, C. T., and D. G. Aubrey, 1994b. Tidal propagation in strongly convergent channels. *Journal of Geophysical Research*, 99: 3321-3336.
- Friedrichs, C. T., and D. G. Aubrey, 1996. Uniform bottom shear stress and equilibrium hypsometry of intertidal flats. In: C. Pattiaratchi (ed.), *Mixing Processes in Estuaries and Coastal Seas*, American Geophysical Union Press, Washington, D.C., p. 421-452..
- Friedrichs, C. T., and D. G. Aubrey and D. R. Lynch, 1990. Non-linear tides in two-dimensions in frictionally-dominated embayments. *EOS*, 71: 1370.
- Friedrichs, C. T., D. G. Aubrey and D. R. Lynch, 1992a. Critical shear stress and equilibrium geometry of tidal channels and tidal embayments. Proceedings, Physics of Estuaries and Coastal Seas, 6th International Conf., Margaret River, Australia, p. 196-199.
- Friedrichs, C. T., D. R. Lynch and D. G. Aubrey, 1992b. Velocity asymmetries in frictionally-dominated tidal embayments: longitudinal and lateral variability. In: D. Prandle (ed.), *Dynamics and Exchanges in Estuaries and the Coastal Zone*, Coastal and Estuarine Studies, Vol. 40, American Geophysical Union, Washington, D.C., p. 277-312.
- Friedrichs, C. T., and O. S. Madsen, 1992. Nonlinear diffusion of the tidal signal in frictionally-dominated embayments. *Journal of Geophysical Research*, 97: 5637-5650.
- Giese, G. S., D. G. Aubrey, and J. T. Liu, 1989. Development, characteristics, and effects of the new Chatham Harbor inlet. Woods Hole Oceanographic Institution, WHOI-89-19, Woods Hole, MA, 32 pp.

- Ip, J. T. C., D. R. Lynch and C.T. Friedrichs, submitted. Simulation of estuarine flooding and dewatering with application to Great Bay, New Hampshire. *Estuarine Coastal and Shelf Science*.
- Penniman, C. A., F. T. Short, and S. E. Adams, 1989. Bibliography of research on the Great Bay estuary and adjacent upland region. University of New Hampshire/ University of Maine Sea Grant College Program, UNHMP-AR-SG-89-2, 113 pp.
- Postma, H., 1967, Sediment transport and Sedimentation in the estuarine environment. In: G. H. Lauff (ed.), *Estuaries*, American Association for the Advancement of Science, Washington, D.C., p. 158-179.
- Short, F. T., 1992. (ed.) The ecology of the Great Bay estuary, New Hampshire and Maine: an estuarine profile and bibliography. NOAA - Coastal Ocean Program Publication, 222 pp.
- Speer, P. E., and D. G. Aubrey, 1985. A study of non-linear tidal propagation in shallow inlet/estuarine systems, part II: theory. *Estuarine, Coastal and Shelf Science*, 21: 207-224.

DOCUMENT LIBRARY

Distribution List for Technical Report Exchange – September 1997

University of California, San Diego
SIO Library 0175C
9500 Gilman Drive
La Jolla, CA 92093-0175

Hancock Library of Biology & Oceanography
Alan Hancock Laboratory
University of Southern California
University Park
Los Angeles, CA 90089-0371

Gifts & Exchanges
Library
Bedford Institute of Oceanography
P.O. Box 1006
Dartmouth, NS, B2Y 4A2, CANADA

NOAA/EDIS Miami Library Center
4301 Rickenbacker Causeway
Miami, FL 33149

Research Library
U.S. Army Corps of Engineers
Waterways Experiment Station
3909 Halls Ferry Road
Vicksburg, MS 39180-6199

Institute of Geophysics
University of Hawaii
Library Room 252
2525 Correa Road
Honolulu, HI 96822

Marine Resources Information Center
Building E38-320
MIT
Cambridge, MA 02139

Library
Lamont-Doherty Geological Observatory
Columbia University
Palisades, NY 10964

Library
Serials Department
Oregon State University
Corvallis, OR 97331

Pell Marine Science Library
University of Rhode Island
Narragansett Bay Campus
Narragansett, RI 02882

Working Collection
Texas A&M University
Dept. of Oceanography
College Station, TX 77843

Fisheries-Oceanography Library
151 Oceanography Teaching Bldg.
University of Washington
Seattle, WA 98195

Library
R.S.M.A.S.
University of Miami
4600 Rickenbacker Causeway
Miami, FL 33149

Maury Oceanographic Library
Naval Oceanographic Office
Building 1003 South
1002 Balch Blvd.
Stennis Space Center, MS, 39522-5001

Library
Institute of Ocean Sciences
P.O. Box 6000
Sidney, B.C. V8L 4B2
CANADA

National Oceanographic Library
Southampton Oceanography Centre
European Way
Southampton SO14 3ZH
UK

The Librarian
CSIRO Marine Laboratories
G.P.O. Box 1538
Hobart, Tasmania
AUSTRALIA 7001

Library
Proudman Oceanographic Laboratory
Bidston Observatory
Birkenhead
Merseyside L43 7 RA
UNITED KINGDOM

IFREMER
Centre de Brest
Service Documentation - Publications
BP 70 29280 PLOUZANE
FRANCE

REPORT DOCUMENTATION PAGE	1. REPORT NO. WHOI-98-02	2.	3. Recipient's Accession No.
4. Title and Subtitle Pressure/Temperature Logger (PTL) Development and Field Deployment for the Great Bay, NH, Tidal Dynamics Experiment			5. Report Date January 1998
7. Author(s) Carl T. Friedrichs ¹ , Wayne D. Spencer ² and David G. Aubrey ²			6.
9. Performing Organization Name and Address ¹ College of William and Mary, School of Marine Science, Virginia Institute of Marine Science, Gloucester Point, VA 23062-1346 ² Woods Hole Oceanographic Institution Woods Hole, Massachusetts 02543			8. Performing Organization Rept. No. WHOI-98-02
12. Sponsoring Organization Name and Address National Science Foundation			10. Project/Task/Work Unit No.
			11. Contract(C) or Grant(G) No. (C) OCE92-02429 (G)
			13. Type of Report & Period Covered Technical Report
			14.
15. Supplementary Notes This report should be cited as: Woods Hole Oceanog. Inst. Tech. Rept., WHOI-98-02.			
16. Abstract (Limit: 200 words) During 1992 and 1993 experiments were conducted in the shallow east side of Great Bay, New Hampshire. These experiments were conducted to better understand the morphodynamics and evolutionary tendencies of shallow tidal embayments and intertidal flats. Hardware and software used in the collection of data are described. Discussed also are techniques used to collect data. Six pressure temperature loggers (PTL) and one current meter (TCSWG) were developed for the experiments. Both instruments are internally powered and internally recording. The instruments were developed because no company was found that manufactured a similar instrument within the price range of the project.			
17. Document Analysis a. Descriptors tidal currents morphology b. Identifiers/Open-Ended Terms c. COSATI Field/Group			
18. Availability Statement Approved for public release; distribution unlimited.		19. Security Class (This Report) UNCLASSIFIED	21. No. of Pages 25
		20. Security Class (This Page)	22. Price

