

Woods Hole Oceanographic Institution

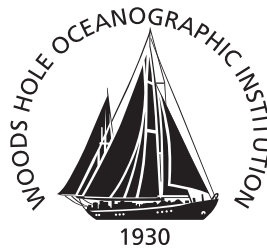

Long-Term Evolution and Coupling of the Boundary Layers in the Stratus Deck Regions of the Eastern Pacific (STRATUS)

by

Lisanne E. Lucas
Bryan S. Way
Robert A. Weller
Paul R. Bouchard
William M. Ostrom
Albert S. Fischer
Carlos F. Moffat
Wolfgang Schneider
Melanie R. Fewings

Woods Hole Oceanographic Institution
Woods Hole, Massachusetts 02543

June 2001

Technical Report

Funding was provided by the National Oceanic and Atmospheric Administration
under grant number NA96GP0429.

Approved for public release; distribution unlimited.



Upper Ocean Processes Group
Woods Hole Oceanographic Institution
Woods Hole, MA 02543
UOP Technical Report 2001-01

WHOI-2001-04

UOP 2001-01

**Long-Term Evolution and Coupling
of the Boundary Layers in the Stratus Deck Regions
of the Eastern Pacific (STRATUS)**

by

Lisanne E. Lucas
Bryan S. Way
Robert A. Weller
Paul R. Bouchard
William M. Ostrom
Albert S. Fischer
Carlos F. Moffat
Wolfgang Schneider
Melanie R. Fewings

June 2001

Technical Report

Funding was provided by the National Oceanic and Atmospheric Administration under grant number NA96GP0429.

Reproduction in whole or in part is permitted for any purpose of the United States Government. This report should be cited as Woods Hole Oceanog. Inst. Tech. Rept., WHOI-2001-04.

Approved for public release; distribution unlimited.

Approved for Distribution:

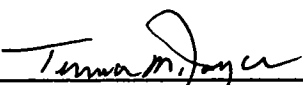

Terrence M. Joyce, Chair

Department of Physical Oceanography



0 0301 0042540 1

**Long-Term Evolution and Coupling of the Boundary Layers in the
Stratus Deck Regions of the Eastern Pacific
(STRATUS)**

Mooring Deployment Cruise Report
R/V *Melville* Cruise Number Cook 2
2 October - 14 October 2000

by

Lisanne E. Lucas
Bryan S. Way
Robert A. Weller
Paul R. Bouchard
William M. Ostrom
Albert S. Fischer
Carlos F. Moffat
Wolfgang Schneider
Melanie R. Fewings

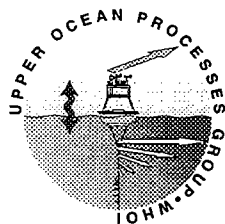

Upper Ocean Processes Group
Woods Hole Oceanographic Institution
Woods Hole, Massachusetts 02543

UOP Technical Report 01-01

Abstract

A surface mooring was deployed in the eastern tropical Pacific west of northern Chile from the R/V *Melville* as part of the Eastern Pacific Investigation of Climate (EPIC). EPIC is a CLIVAR study with the goal of investigating links between sea surface temperature variability in the eastern tropical Pacific and climate over the American continents. Important to that goal is an understanding of the role of clouds in the eastern Pacific in modulating atmosphere-ocean coupling. The mooring was deployed near 20°S 85°W, at a location near the western edge of the stratocumulus cloud deck found west of Peru and Chile. This deployment started a three-year occupation of that site by a WHOI surface mooring in order to collect accurate time series of surface forcing and upper ocean variability.

The surface mooring was deployed by the Upper Ocean Processes Group of the Woods Hole Oceanographic Institution (WHOI). In collaboration with investigators from the University of Concepcion, Concepcion, Chile, an XBT section was also made on the way out to the mooring site from Arica, Chile, and an XBT and CTD section was made on the way into Arica.

The buoy was equipped with meteorological instrumentation, including two Improved METeorological (IMET) systems. The mooring also carried Vector Measuring Current Meters, single-point temperature recorders, and conductivity and temperature recorders located in the upper meters of the mooring line. In addition to the instrumentation noted above, a variety of other instruments, including an acoustic current meter, an acoustic doppler current profiler, a bio-optical instrument package, and an acoustic rain gauge, were deployed.

This report describes, in a general manner, the work that took place and the data collected during the Cook 2 cruise aboard the R/V *Melville*. The surface mooring deployed during this cruise will be recovered and re-deployed after approximately 12 months and again after 24 months, with a final recovery planned for 36 months after the first setting. Details of the mooring design and preliminary data from the XBT and CTD sections are included.

Table of Contents:

ABSTRACT	ii
TABLE OF CONTENTS	iii
LIST OF FIGURES	v
LIST OF TABLES	vii
SECTION 1: INTRODUCTION.....	1
SECTION 2: THE WHOI SURFACE MOORING AND SHIPBOARD SAMPLING	3
A. THE SURFACE MOORING	3
1. <i>Meteorological Instrumentation</i>	5
a. Improved METeorological System	11
b. Stand-alone Relative Humidity/Temperature Instrument	11
c. Onset StowAway TidbiT Temperature Loggers.....	11
2. <i>Sub-surface Instrumentation</i>	12
a. Floating SST Sensor.....	12
b. Sub-surface Argos Transmitter.....	12
c. SEACAT Conductivity and Temperature Recorders	12
d. MicroCAT Conductivity and Temperature Recorder.....	12
e. Brancker Temperature Recorders.....	13
f. SBE-39 Temperature Recorder	13
g. Onset StowAway TidbiT Temperature Loggers.....	13
h. Vector Measuring Current Meters.....	13
i. Falmouth Scientific Instruments Current Meter	14
j. RDI Acoustic Doppler Current Profiler	14
k. Chlorophyll Absorption Meter	14
l. Acoustic Rain Gauge	14
m. Acoustic Release	15
B. SHIPBOARD AIR-SEA FLUX SYSTEM	19
C. ANCILLARY SHIPBOARD METEOROLOGICAL AND OCEANOGRAPHIC INSTRUMENTATION.....	19
1. <i>Meteorological Instrumentation Provided by Woods Hole Oceanographic</i>	19
a. ASIMET Relative Humidity/ Air Temperature Specifications.....	20
b. ASIMET Short-wave Radiation Specifications	20
c. ASIMET Long-wave Radiation Specifications	21
2. <i>Independent Meteorological Data Recording System (Shipboard)</i>	22
3. <i>FSI-OCM & FSI-OTM (Shipboard - Thermo-salinograph)</i>	22
4. <i>Acoustic Doppler Current Profiler (Shipboard)</i>	22
5. <i>Sea Beam 2000 (Shipboard)</i>	23
6. <i>Knudsen 320 B/R (Shipboard)</i>	23
7. <i>Shipboard Navigation Systems</i>	23
8. <i>Gravimeter</i>	23
SECTION 3: SAMPLING DURING TRANSITS AND BUOY/SHIP COMPARISON	24
A. OUTBOUND	24
1. <i>Underway Watch</i>	24
2. <i>XBT section</i>	25
3. <i>Intercomparison of ship's sensors with handheld sensors</i>	28
4. <i>Intercomparison of Buoy and Ship IMET sensors after deployment</i>	33
B. INBOUND	34
1. <i>XBT/CTD section</i>	34
SECTION 4: CRUISE CHRONOLOGY.....	41
ACKNOWLEDGMENTS	47
REFERENCES	47
APPENDIX 1: CRUISE PARTICIPANTS.....	48

APPENDIX 2: XBT TEMPERATURE PROFILES	49
APPENDIX 3: WHOI INSTRUMENTATION DEPLOYED DURING STRATUS 1	58
A. INSTRUMENT INFORMATION (SERIAL NUMBERS, DEPLOY TIME, SAMPLING RATES).....	58
B. MOORING LOG.....	60
C. INSTRUCTIONS FOR LOADING THE RDI WORKHORSE ADCP IN TO CAGE	68
APPENDIX 5: STRATUS MOORING DEPLOYMENT PROCEDURES	69
APPENDIX 6: STRATUS ANTIFOULING COATING TEST	80
APPENDIX 7: SHIPBOARD AIR-SEA FLUX SYSTEM PROCEDURE DETAILS.....	84
APPENDIX 8: DATA COLLECTED DURING THE COOK 02 CRUISE ON THE R/V MELVILLE	86
SEABEAM, GRAVITY, AND NAVIGATION SHIPBOARD DATA	86
SHIPBOARD ADCP, ZONAL AND MERIDIONAL CURRENTS.	89
SHIPBOARD IMET AND THERMO-SALINOGRAPH SENSORS.....	90
ASIMET LONGWAVE RADIATION, RELATIVE HUMIDITY, AIR TEMPERATURE, AND INCOMING SHORTWAVE RADIATION.....	93

List of Figures

Figure 1: STRATUS mooring cruise schedule.....	1
Figure 2: Cruise track and mooring locations.	2
Figure 3: STRATUS 1 mooring diagram.....	4
Figure 4: STRATUS 1 Buoy IMET Towertop.....	5
Figure 5: Buoy spin orientation for pre-deployment test at WHOI.....	8
Figure 6: Pre-deployment Buoy Spin at WHOI.	9
Figure 7: Buoy orientation for the spin done in Arica, Chile.....	10
Figure 8: Spin data plot for Arica, Chile.....	10
Figure 9: Location of the ASIMET Modules	20
Figure 10: Visual observations of cloud type and cover made by the outbound underway watch.	25
Figure 11: Location of XBT casts with good data in the outbound direction.....	26
Figure 12: Sea surface temperatures from XBT casts (0.67 m) and bucket casts.....	27
Figure 13: Contour plot of temperature from the good XBT stations in the outbound direction. Dots on the top x-axis mark the location of the included XBT casts. The top bound in temperature (above 22°C) is set by spikes in the near-surface temperature data visible near the coast.....	28
Figure 14: Overplots of Ship IMET, Buoy IMET, handheld, and written ship logs of air temperature, barometric pressure, and relative humidity.....	30
Figure 15: Overplots of Ship IMET, Buoy IMET, handheld, and written ship logs of sea surface temperature and salinity from the ship's thermosalinograph. The last plot is of the flow past the thermosalinograph, verifying that the pump was on while on station.....	31
Figure 16: Overplots of Ship IMET, Buoy IMET, handheld, and written ship logs longwave and shortwave radiation, and precipitation.	32
Figure 17: Alongtrack wind vectors calculated from the ship's IMET and GPS sensors, averaged every 30 minutes.....	33
Figure 18: Comparison of ship IMET wind speed and buoy IMET wind speeds while on station after the buoy deployment. The time axis extends from the time of deployment to the time the ship left its monitoring station, 0.25 miles downwind of the buoy. Ship IMET wind speed is uncorrected, but the ship was holding station during this time.....	34
Figure 19: CTD stations one, two, three and four.	36
Figure 20: CTD stations five, six, seven and eight.....	37
Figure 21: CTD stations nine, ten, eleven and twelve.....	38
Figure 22: CTD station thirteen.....	39
Figure 23: Inbound CTD transect profile.....	39
Figure 24: Course track for carrying out the bottom survey using the SeaBeam on October 5-6, 2000.....	42
Figure 25: Contour plot of the bottom topography mapped during the survey.....	43
Figure 26: Target track path (black line) and ship's track (green) recorded by GPS during the mooring deployment, the acoustic survey of the anchor position, and the subsequent occupation of a position 1/4 mile downwind of the surface buoy.....	45
Figure 27: Figure showing the intersection of three horizontal range arcs based on slant ranges obtained at three survey points. The small blue circle is the position at which the anchor	

was deployed and the X marks a best estimate of the position on the bottom of the anchor.

.....	45
Figure 28: Profile plots of the XBT station data by station number, separated by 10°C.	52
Figure 29: Profile plots of the XBT station data, separated by 10°C.	53
Figure 30: Profile plots of the XBT station data, separated by 10°C.	54
Figure 31: Profile plots of the XBT station data, separated by 10°C.	55
Figure 32: Profile plots of the XBT station data, separated by 10°C.	56
Figure 33: Profile plots of the XBT station data, separated by 10°C.	57
Figure 36: Diagram describing insertion of RDI ADCP into cage.	68
Figure 37: Basic deck equipment and deck layout.....	70
Figure 38: Three slip lines rigged on the discus to maintain constant swing control during the lift.	73
Figure 39: H-Bit winding for releasing the final 2000 m of line.	75
Figure 40: Details how this line was reeved around the H-bit.....	76
Figure 41: Position of the line handler and assistant.	76
Figure 42: Eighty-one glass balls in hard hats stowed on deck for deployment.....	77
Figure 43: Diagram of the Discus Buoy and Painting Scheme.....	83
Figure 44: Track plot of the STRATUS 1 cruise. Positions are marked for noon local time.	86
Figure 45: Ship Course, Speed, and Distance Traveled (by Date).....	87
Figure 46: SeaBeam Water Depth, Gravity, and Gravity Anomaly (by Date)	88
Figure 47: Zonal and Meridional Currents for the Shipboard ADCP.	89
Figure 48: Air Temperature, Barometric Pressure, SST, and Relative Humidity from Shipboard IMET sensors.....	90
Figure 49: Longwave and Shortwave radiation, Wind speed and direction.	91
Figure 50: Precipitation, Sigma t, Sound velocity, and Sea surface conductivity.	92
Figure 51: Dew Point, Sea Surface Salinity, and Flow through the Thermo-Sal.....	92
Figure 52: ASIMET Longwave Radiation (shown with Thermopile voltage).	93
Figure 53: ASIMET Relative Humidity and Shortwave Radiation.....	94

List of Tables

Table 1: STRATUS mooring deployment information	2
Table 2: Meteorological sensor serial numbers STRATUS WHOI discus buoy.	6
Table 3: Pre-Deployment Buoy Spin done at WHOI. IMET 1, 2 and 3 compass/vane listings. ...	7
Table 4: Buoy Spin done on the dock in Arica, Chile. IMET 1 and 2 compass/vane listings.	9
Table 5: IMET sensor specifications	16
Table 6: STRATUS buoy tower sensor information.	17
Table 7: STRATUS subsurface sensor information.	18
Table 8: Instrumentation mounted on 03 level on R/V <i>Melville</i>	21
Table 9: CTD locations and times.	40
Table 10: Sampling at each location.....	40
Table 11: Outbound XBT station locations, filenames, and comments.	49
Table 12: Locations of CTD casts	51
Table 13: Instrumentation Mounted On 3 Meter Discus Buoy Tower And Bridle.....	58
Table 14: Instrumentation mounted on the mooring line of the 3 meter discus buoy	59
Table 15: Weights per unit area and estimated film thickness of antifouling paints applied to the STRATUS discus buoy.	81
Table 16: Information regarding the antifoulants applied to instrumentation.	82

Section 1: Introduction

The second leg of the R/V *Melville's* fall 2000 expedition, Cook 2, departed Arica, Chile, on October 2, 2000, at 1800 hours local time (2200 UTC, October 2, 2000) with a science party (Appendix 1) from Woods Hole Oceanographic Institution (WHOI), Servicio Hidrográfico y Oceanográfico de la Armada de Chile (SHOA), the Universidad de Concepción (UdeC), and the Universidad Católica de Valparaíso (UCV). The goals of the cruise were to deploy a surface mooring under the stratocumulus cloud deck west of Chile (starting a 3-year occupation of that site, Figure 1), to observe the air-sea fluxes during the transit between Arica and the mooring site, to make an XBT section during the transit out of Arica, and to make an XBT and CTD section with water sampling and analyses during the transit back into Arica. The mooring deployment was part of CLIVAR studies of the eastern Pacific examining the long-term temporal evolution of the upper ocean and of the cloud deck and the coupling between the ocean and atmosphere in this region. The objectives of the XBT and CTD sections were to analyze the water masses of the Chilean Basin and to study the vertical and cross-shore extent of the oxygen minimum zone. In addition, the nutrient status of the Basin would be determined and the microplankton biomass examined throughout the water column. SHOA personnel were participating as national observers from Chile.

The cruise track (Figure 2) started to the southwest, running roughly perpendicular to the coast until the 20°S latitude line was intersected and then west to the mooring (Figure 2). XBTs were dropped every 30 minutes once outside the 12 mile limit of Chilean waters; the locations and profiles on the outbound leg are summarized in Appendix 2. The CTD station and XBT profile locations on the inbound leg are summarized in Table 11 and Table 12 and the profiles in Appendix 2 and Section 3B. Details of the mooring deployment are summarized Table 1.

Including this introduction, the report has four sections. The second section primarily describes the WHOI mooring and its instrumentation, the third section describes the transects, and the fourth section presents a chronology of the cruise.

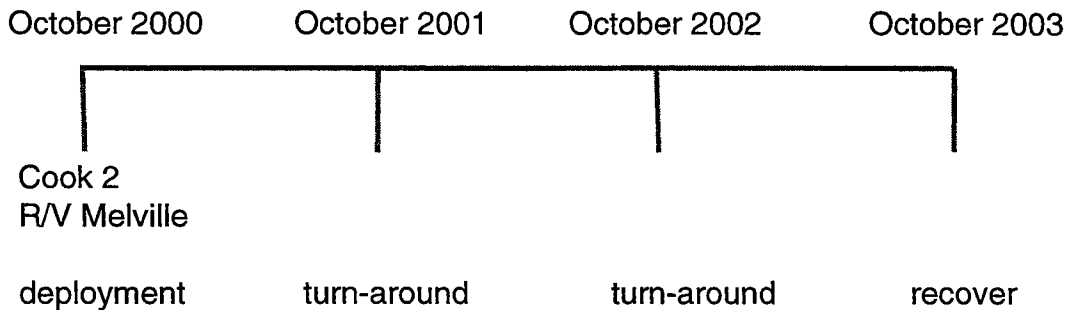

Figure 1: STRATUS mooring cruise schedule.

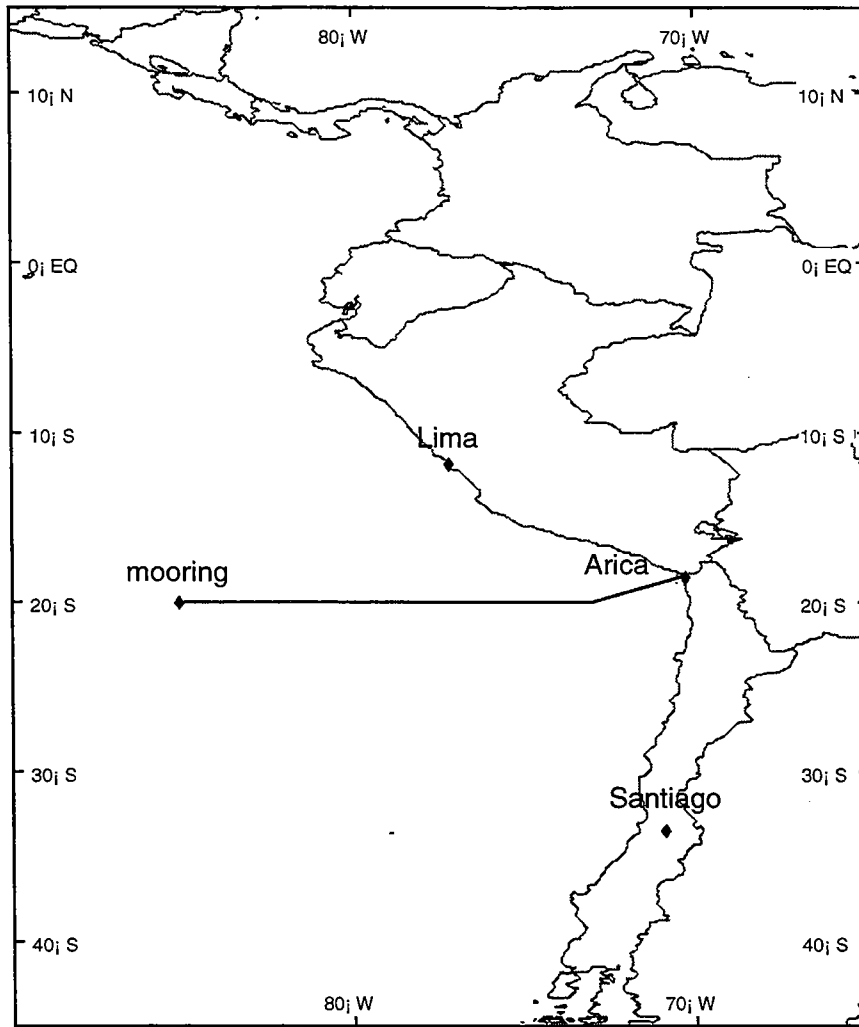

Figure 2: Cruise track and mooring locations.

Table 1: STRATUS mooring deployment information

Mooring	Deployment Date and Time	Anchor Position
WHOI STRATUS 1 Discus Buoy (WHOI Moor. Reference No. 1052)	7 October 2000 @20:43:00 UTC	20° 9.4174'S 085° 9.0729'W Water Depth: 4440 m

Section 2: The WHOI Surface Mooring and Shipboard Sampling

A. The Surface Mooring

One surface mooring was deployed during cruise Cook 2 of the R/V *Melville*. The three meter discus buoy was equipped with meteorological instrumentation, including two Improved METeorological (IMET) recorders, and a stand-alone humidity and temperature recorder. The WHOI mooring also carried vector measuring current meters, temperature recorders, and conductivity and temperature recorders located in the upper 450 meters of the mooring line, as well as an Acoustic Doppler current profiler, a Falmouth Scientific Instruments (FSI) current meter, a chlorophyll absorption meter, 4 Onset Tidbit temperature loggers, and an acoustic rain gauge. Figure 3 schematically shows the mooring and the location of the sub-surface instrumentation.

A total of 41 recording instruments with 72 sensors were deployed on the STRATUS 1 surface mooring. There are two meteorological systems, one stand-alone relative humidity/air temperature recorder (SAHTR), one floating sea surface temperature recorder, three current meters, sixteen temperature data loggers, ten conductivity/temperature-recording instruments, one chlorophyll absorption meter (CHLAM), one acoustic rain gauge, and one acoustic current meter.

All of the instrumentation used on the WHOI moorings had some type of pre-deployment time mark applied (Appendix 3, Table 13 and Table 14). The two Improved METeorological (IMET) recorders had their short-wave radiation sensors black bagged for two record cycles. The VMCMs had their rotors spun. All of the temperature recorders were put in an ice bath for their time intervals. The time marks will be used to verify the accuracy of the instrument's clock in data processing. Appendix 3 has a complete listing of all instrumentation deployed during Cook 2. For each instrument, the listing shows the instrument type, sampling interval, instrument serial number and the corresponding depth.

The surface mooring has seventeen meteorological sensors mounted on the top half of the buoy tower (Figure 4) and are described in this section. Five near-surface oceanographic sensors are attached to the bridle and buoy hull. In addition to the buoy-mounted instruments, the STRATUS 1 mooring supports an additional 34 recording packages, some of which have multiple sensors.

The STRATUS 1 mooring is shown schematically in Figure 3. This WHOI mooring is an inverse catenary design utilizing wire rope, chain, nylon and polypropylene line and a scope of 1.25 (Scope = slack length/water depth). The surface buoy is a three-meter diameter discus buoy with a two-part aluminum tower and rigid bridle.

The design of these surface moorings took into consideration the predicted currents, winds, and sea-state conditions expected during the deployment duration. Further, they were constructed using hardware and designs that had been proven in the recent PACS deployment.

MAXIMUM DIAMETER OF BUOY
WATCH CIRCLE = 3.72 N. MILES

3 meter Discus Buoy with following Equipment:

- 2 IMET, both with Argos Telemetry
- 1 Additional ASIMET HRH with Vaisala sensor
- Floating Sea Surface Temperature Sensor
- 1 TidBit temperature logger

NOTE: All T-pods, Microcats, Seacats and SBE-39s are to be installed on the mooring with the sensors up.

No Foul & Clear
Coat TBT on cages
above 70 m.

Note: All instruments without cages have protective trawler guards

TERMINATION CODES	
A	BRIDLE: U-JOINT, 1" CHAIN SHACKLE 1" ENDLINK, 7/8" CHAIN SHACKLE
C	3/4" CHAIN SHACKLE, 7/8" ENDLINK, 3/4" CHAIN SHACKLE
D	3/4" CHAIN SHACKLE, 3/4" ANCHOR SHACKLE
E	3/4" ANCHOR SHACKLE, 7/8" ENDLINK, 3/4" ANCHOR SHACKLE
F	1" ANCHOR SHACKLE, 7/8" ENDLINK, 5/8" CHAIN SHACKLE
G	5/8" CHAIN SHACKLE, 7/8" ENDLINK, 5/8" CHAIN SHACKLE
H	5/8" CHAIN SHACKLE, 7/8" ENDLINK, 7/8" ANCHOR SHACKLE

HARDWARE REQUIRED (INCLUDES APPROX. 20% SPARES)	
1" CHAIN SHACKLES	2
1" ANCHOR SHACKLES	2
1" WELDLESS END LINK	2
7/8" ANCHOR SHACKLES	4
7/8" CHAIN SHACKLES	2
7/8" WELDLESS LINKS	120
3/4" CHAIN SHACKLES	163
3/4" ANCHOR SHACKLES	11
5/8" CHAIN SHACKLES	60

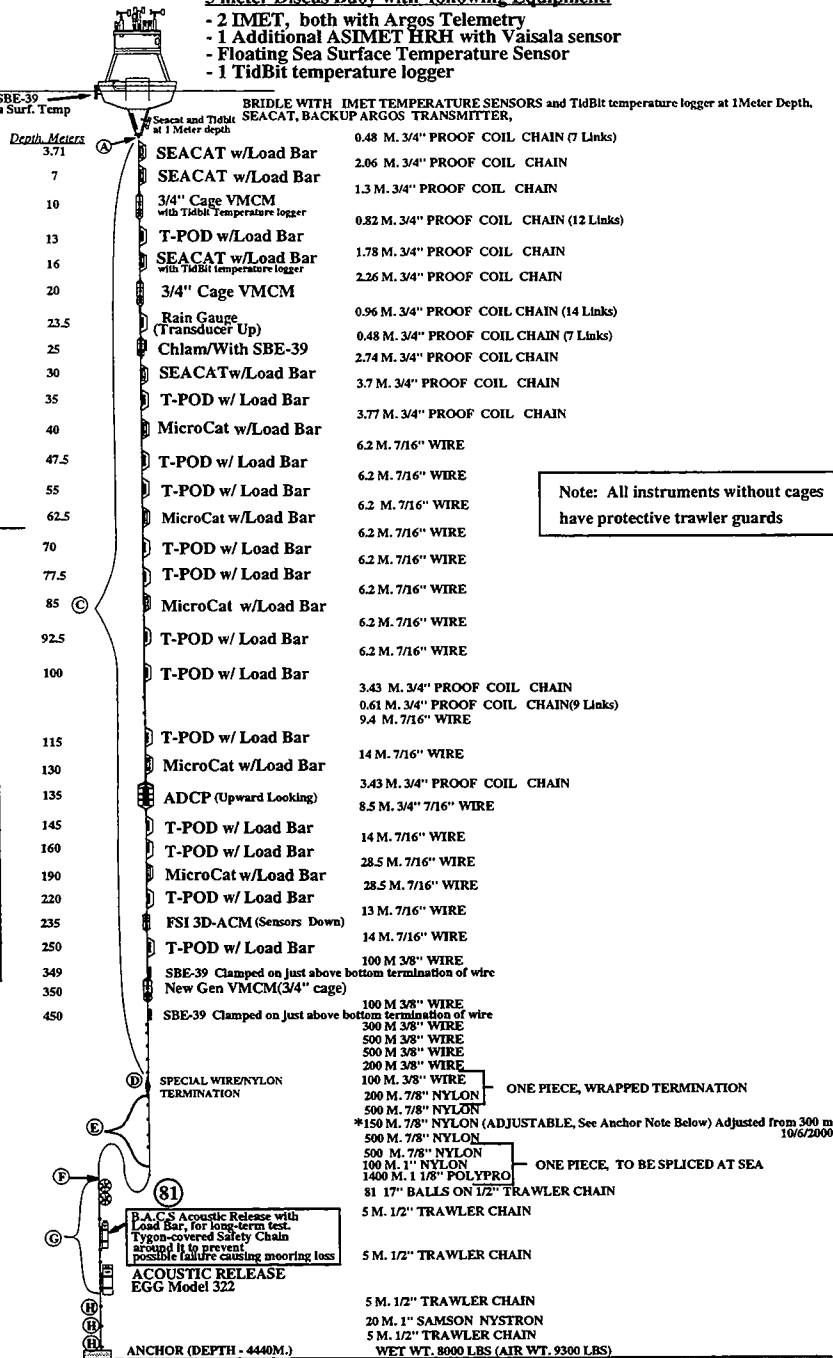

* Note: No adjustment required if the water depth is within plus or minus 100 Meters.

G. Tupper/E. Greeley 30 Dec 99
 Rev 1 - 31 Jan 00
 Rev 2 - 23 Mar 00
 Rev 3 - 11 Jul 00
 Rev 4 - 11 Jul 00
 Rev 5 - 18 Jul 00
 Rev 6 - 8 Aug 00
 Revised at Sea - 6 Oct 00
 Final after deploy - 8 Oct 00

STRATUS MOORING

First Deployment

Figure 3: STRATUS 1 mooring diagram.

1. Meteorological Instrumentation

The discus buoy was outfitted with two separate and redundant meteorological packages. The meteorological data recording system, IMET, logged data from eight meteorological sensors at one minute intervals; this data was averaged into one hour intervals and telemetered via Service Argos. A separate relative humidity and air temperature instrument made an independent measurement and recorded the data internally. Figure 4 shows the mounting locations and orientations of the instruments as they were deployed on the STRATUS 1 mooring.

Figure 4 shows a top view of the meteorological instrumentation mounted on the WHOI discus buoys; Table 2 gives the serial numbers of the sensors and modules of the meteorological instruments. Two buoy spins of the STRATUS 1 buoy were performed. The first was done as part of the pre-deployment procedure at WHOI and the second at the dock in Arica to confirm that the compasses of each IMET were in proper working order. The data from the pre-deployment buoy spins are as follows: Table 3 IMET System 1, 2, and 3 compass/vane listings; Figure 5 buoy spin orientation; Figure 6 plots of buoy spin data. The Arica spin data is listed in Table 4, Figure 7 and Figure 8. The instrument systems deployed on the STRATUS 1 mooring are described in detail below.

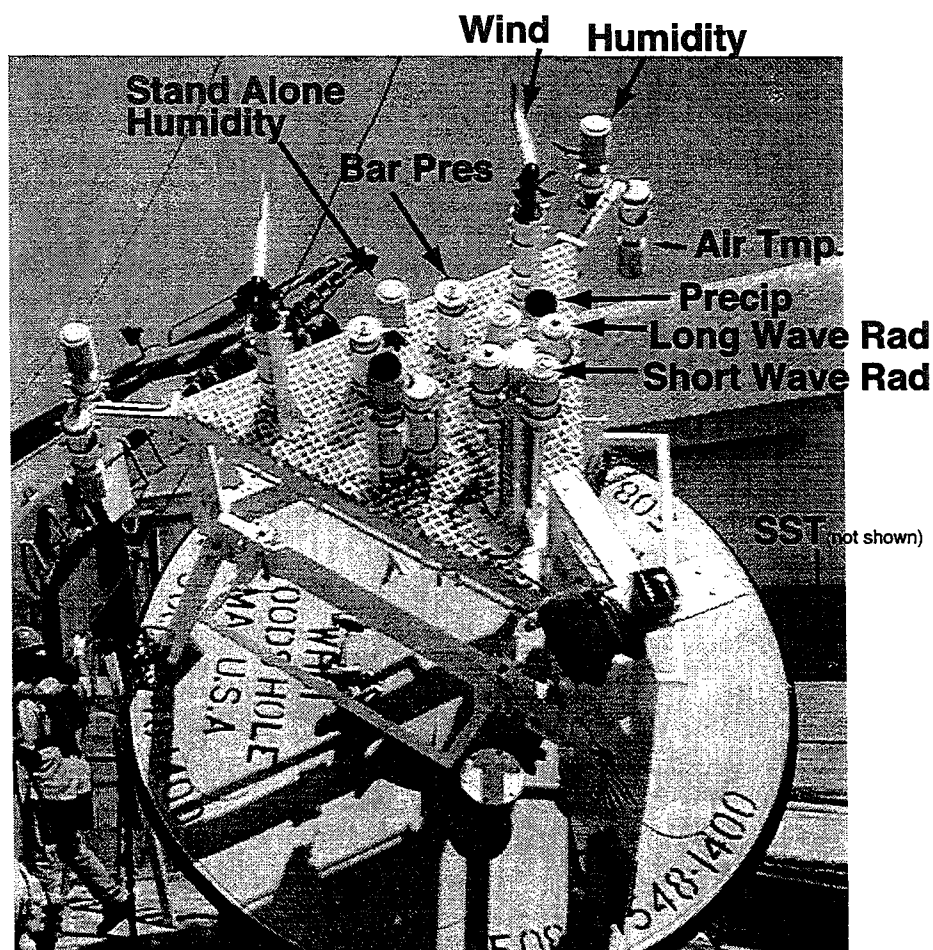

Figure 4: STRATUS 1 Buoy IMET Towertop.

Table 2: Meteorological sensor serial numbers STRATUS WHOI discus buoy.

STRATUS-1

IMET 1

WND	104
SWR	111
LWR	101
HRH	108
BPR	107
SST	003
TMP AT	102
PRC	102
LOGGER	117
PTT	
ARGOS I.D. #1	27916
ARGOS I.D. #2	27917
ARGOS I.D. #3	27918

IMET 2

WND	105
SWR	109
LWR	106
HRH	110
BPR	106
SST	104
TMP AT	104
PRC	101
LOGGER	226
PTT	
ARGOS I.D. #1	27919
ARGOS I.D. #2	27920
ARGOS I.D. #3	27921

STAND-ALONE

HRH	204
-----	-----

**Table 3: Pre-Deployment Buoy Spin done at WHOI.
IMET 1, 2 and 3 compass/vane listings.**

STRATUS PRE-DEPLOYMENT BUOY SPIN TEST
WHOI - 309 degrees

30-Jun-00

POSITION #		DIRECTION	VANE	COMPASS
1	IMET - 1	309.6	242.9	67
1	IMET - 2	307.1	153.3	154
2	IMET - 1	308.3	182.1	126.3
2	IMET - 2	307.7	92.8	214.9
3	IMET - 1	307.8	123	184.7
3	IMET - 2	308	33	275
4	IMET - 1	307	61.9	245.1
4	IMET - 2	310.3	334	336.4
5	IMET - 1	308.5	1.4	307.4
5	IMET - 2	309.9	274.2	35.5
6	IMET - 1	308.6	301.6	7.1
6	IMET - 2	309.7	215.9	93.4

IMET 1 = DATA LOGGER S/N 117
IMET 2 = DATA LOGGER S/N 226

IMET 1 = WND104
IMET 2 = WND105

STRATUS PRE-DEPLOYMENT BUOY SPIN TEST
WHOI - 309 degrees

30-Jun-00
STRATUS (SPARE)

POSITION #		DIRECTION	VANE	COMPASS
1	IMET - 3	306.8	156.1	150.7
2	IMET - 3	311.5	94.9	216.6
3	IMET - 3	312	35.9	276.3
4	IMET - 3	311	337.5	333.4
5	IMET - 3	307.1	227	30.1
6	IMET - 3	305.6	214.5	91.1

IMET 3 = DATA LOGGER S/N 295

IMET 3 = WND111

STRATUS PRE-DEPLOYMENT BUOY SPIN
 WHOI TEST SITE- BUOY ORIENTATION - 30 JUNE 00

BEARING - 309 DEGREES

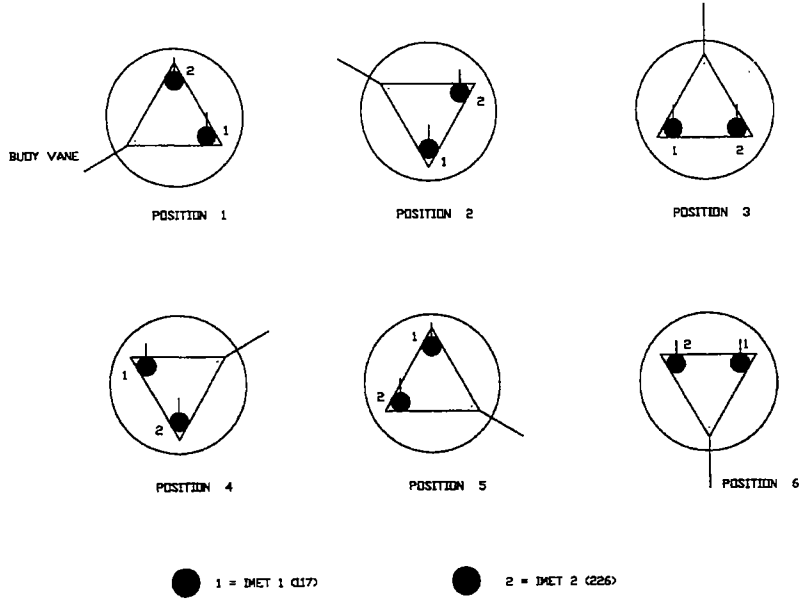

STRATUS PRE-DEPLOYMENT BUOY SPIN (SPARE IMET)
 WHOI TEST SITE- BUOY ORIENTATION - 30 JUNE 00

BEARING - 309 DEGREES

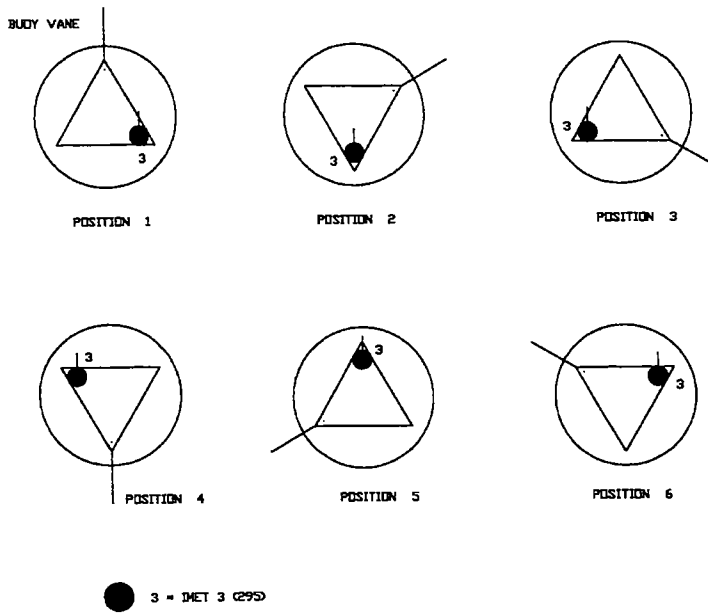

Figure 5: Buoy spin orientation for pre-deployment test at WHOI.

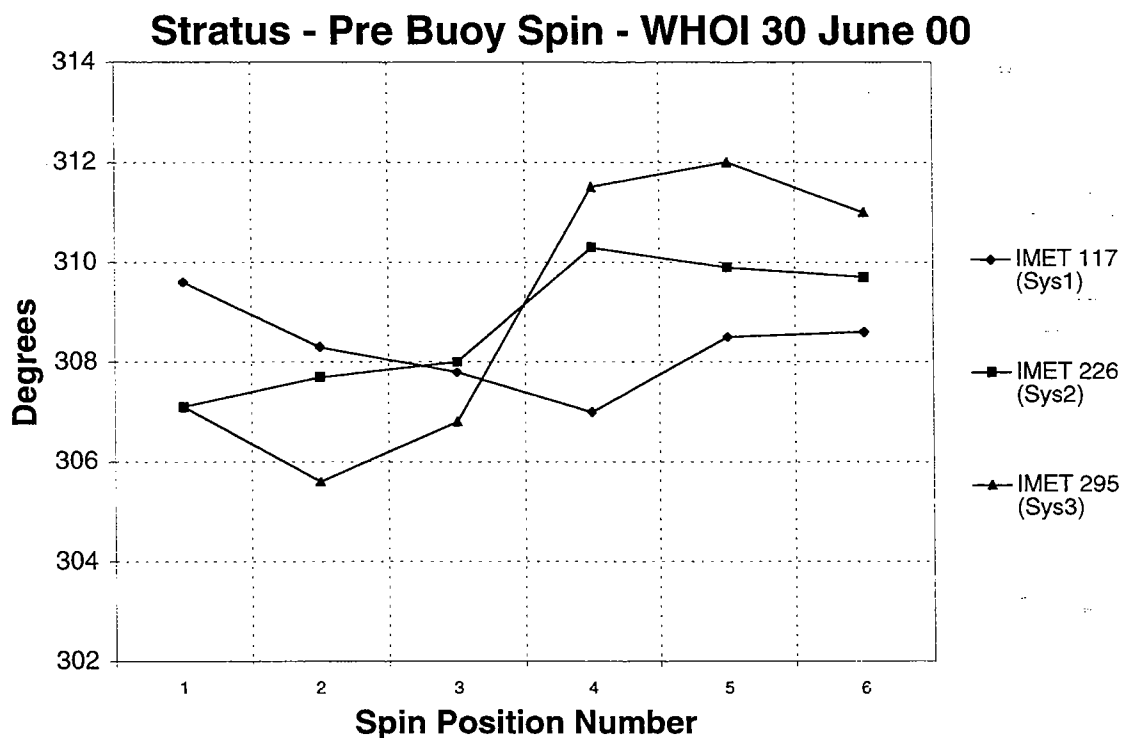

Figure 6: Pre-deployment Buoy Spin at WHOI.

Table 4: Buoy Spin done on the dock in Arica, Chile. IMET 1 and 2 compass/vane listings.

STRATUS PRE-DEPLOYMENT BUOY SPIN TEST
ARICA, CHILE - 90 DERGEES AT SMOKE STACK

27-Sep-00

POSITION #		DIRECTION	VANE	COMPASS
1	IMET - 1	91.4	2.8	88.6
1	IMET - 2	91.4	276.3	175.1
2	IMET - 1	89.4	300.9	148.5
2	IMET - 2	91.4	213.8	237.6
3	IMET - 1	87.3	241.2	206.1
3	IMET - 2	91.9	154	297.9
4	IMET - 1	87.2	182.8	264.4
4	IMET - 2	90.4	94.2	356.2
5	IMET - 1	90.6	123	327.6
5	IMET - 2	90.2	33.8	56.4
6	IMET - 1	94.5	63.3	31.2
6	IMET - 2	87	330.5	116.5

IMET 1 = DATA LOGGER S/N 117
IMET 2 = DATA LOGGER S/N 226

STRATUS PRE-DEPLOYMENT BUOY SPIN
 ARICA, CHILE BUOY ORIENTATION 27 SEPT 00

BEARING - 90 DEGREES

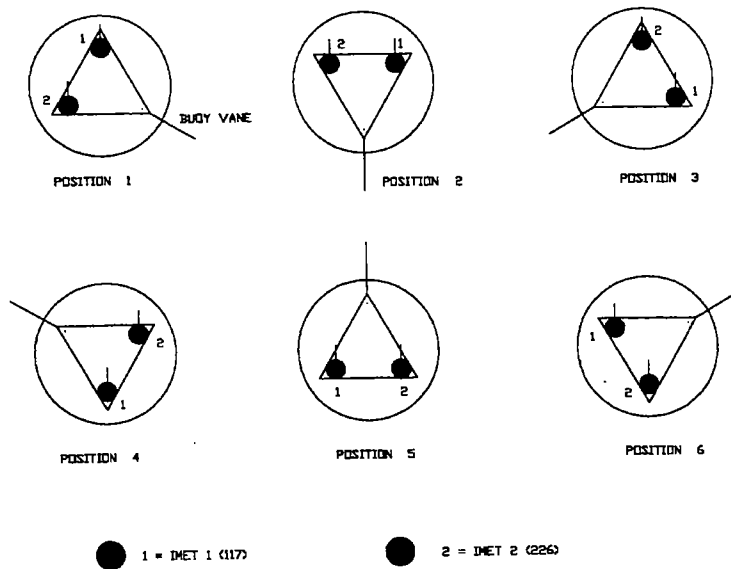

Figure 7: Buoy orientation for the spin done in Arica, Chile.

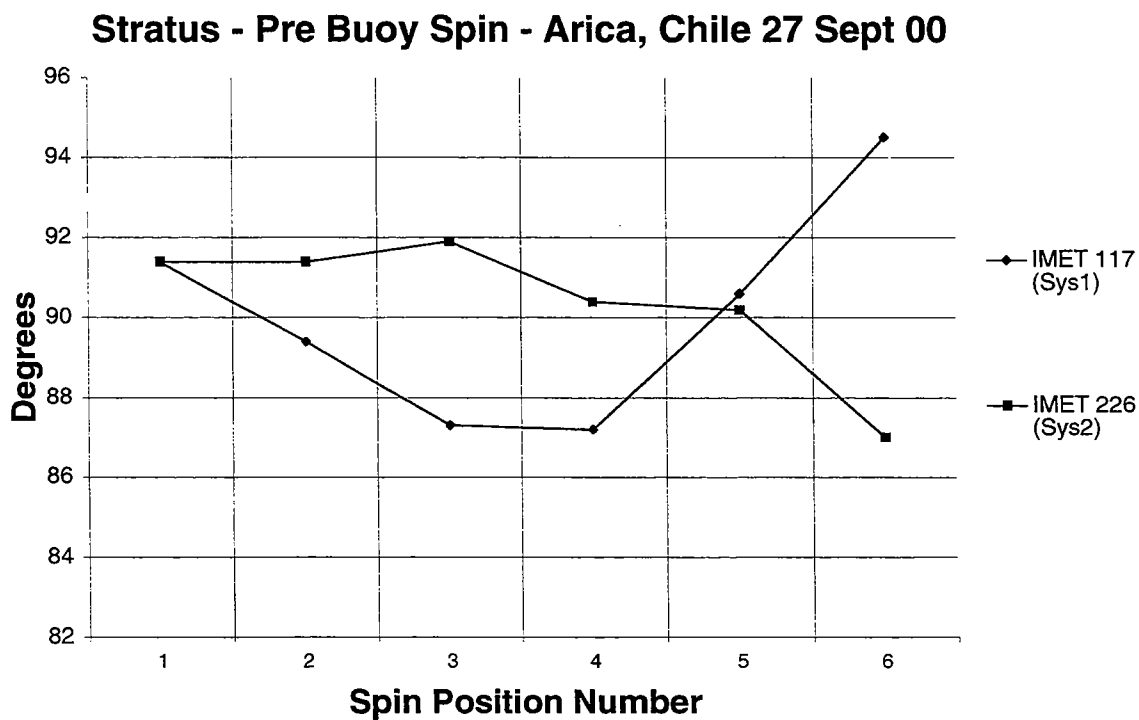

Figure 8: Spin data plot for Arica, Chile.

a. Improved METeorological System

The IMET systems for the STRATUS 1 discus buoy consisted of eight IMET sensor modules and one Argos transmitter module to telemeter data via satellite back to WHOI through Service Argos. Table 5 details IMET sensor specifications. The modules measure the following parameters:

1. relative humidity with temperature
2. barometric pressure
3. air temperature (R. M. Young passive shield)
4. sea surface temperature
5. precipitation
6. wind speed and direction
7. short-wave radiation
8. long-wave radiation

All IMET modules for the STRATUS experiment were modified for lower power consumption so that a non-rechargeable alkaline battery pack could be used.

The data logger for the system was based on an Onset Computer Corp. model 7 Tattletale computer with hard drive, also configured and programmed with power conservation in mind. An associated interface board ties the model 7 via individual power and RS-485 communications lines to each of the nine IMET modules, including the PTT module.

b. Stand-alone Relative Humidity/Temperature Instrument

A self-contained relative humidity and air temperature instrument was mounted on the tower of the WHOI discus buoys. This instrument, developed and built by members of the UOP Group, takes a single point measurement of both relative humidity and temperature at a desired record interval. The sensor used was a Rotronics MP-101A. The relative humidity and temperature measurements are made inside a protective Gortex shield. The logger is an Onset Computer, Corp., model 4A Tattletale, with expanded memory to 512K. The unit is powered by its own internal battery pack. The instrument interval was set to 1 minute for the STRATUS 1 Experiment.

c. Onset StowAway TidbiT Temperature Loggers

The Tidbit temperature logger is a completely sealed, small (~3 cm diameter) medallion like temperature logger. It is depth rated to approximately 300 m (1,000 ft.) and has an operating temperature range of -20° to +50°C. The tidbit uses optical communication via an Optical Base Station that plugs into a standard PC serial port. One Tidbit was placed on the IMET system #2 air temperature module, co-located with the sensor. The sampling rate was set to once every 30 minutes.

The height of the buoy mounted instrumentation can be found in Table 6.

2. Sub-surface Instrumentation

The measured water line for the STRATUS 1 buoy was 0.43 meters below the buoy deck. Figure 3 illustrates the location of the sub-surface sensors attached to the discus bridle of the STRATUS 1 buoy. The depths of the instruments, parameters sampled, and sampling rates are summarized in Table 7. Whenever possible, "trawl-guards", designed and fabricated at WHOI, protected instruments from being fouled by fishing lines. These guards are meant to keep lines from hanging up on the in-line instruments.

a. Floating SST Sensor

A SeaBird SBE-39 was placed in a floating holder (a buoyant block of synthetic foam sliding up and down along 3 stainless steel guide rods) in order to sample the sea temperature as close as possible to the sea surface. Visual check of this sensor after deployment indicated a depth of ~2 cm. The Seabird model SBE-39 is a small, light weight, durable and reliable temperature logger that was set to record the sea surface temperature every 5 minutes.

b. Sub-surface Argos Transmitter

An NACLS, Inc. Sub-surface Mooring Monitor (SMM) was mounted upside down on the bridle of the discus buoy. This was a backup recovery aid in the event that the mooring parted and the buoy flipped upside down.

c. SEACAT Conductivity and Temperature Recorders

There were five, Sea-Bird, Inc., SEACAT conductivity and temperature recorders deployed on the WHOI surface mooring. The model SBE 16 SEACAT was designed to measure and record temperature and conductivity at high levels of accuracy while deployed in either a fixed or moored application. Powered by internal batteries, a SEACAT is capable of recording data for periods of a year or more. Data are acquired at intervals set by the user. An internal back-up battery supports memory and the real-time clock in the event of failure or exhaustion of the main battery supply. Communication with the SEACAT is over a three-wire RS-232 link. The SEACAT is capable of storing a total of 260,821 samples. A sample rate of 225 seconds was used on the STRATUS 1 SEACATs. The shallowest SEACAT was mounted directly to the bridle of the discus buoy. The others were mounted on in-line tension bars and deployed at various depths throughout the moorings. The conductivity cell is protected from bio-fouling by the placement of antifoulant cylinders at each end of the conductivity cell tube.

d. MicroCAT Conductivity and Temperature Recorder

The MicroCAT, model SBE37, is a high-accuracy conductivity and temperature recorder with internal battery and memory. It is designed for long-term mooring deployments and includes a standard serial interface to communicate with a PC. Its recorded data are stored in non-volatile FLASH memory. The temperature range is -5° to +35°C, and the conductivity range is 0 to 6 Siemens/meter. The pressure housing is made of titanium and is rated for 7,000 meters. The MicroCAT is capable of storing 419,430 samples of temperature, conductivity and time. The sampling interval of the STRATUS 1 MicroCATs was 225 seconds (3.75 minutes). These

instruments were mounted on in-line tension bars and deployed at various depths throughout the moorings. The conductivity cell is protected from bio-fouling by the placement of antifoulant cylinders at each end of the conductivity cell tube.

e. Brancker Temperature Recorders

The Brancker temperature recorders are self-recording, single-point temperature loggers. The operating temperature range for this instrument is 2° to 34°C. It has internal battery and logging, with the capability of storing 24,000 samples in one deployment. A PC is used to communicate with the Brancker via serial cable for instrument set-up and data download. The STRATUS 1 Branckers were set to record data every 30 minutes. A total of 13 Brancker temperature loggers were deployed on the discus mooring.

f. SBE-39 Temperature Recorder

The Seabird model SBE-39 is a small, light weight, durable and reliable temperature logger that was set to record temperature every 5 minutes.

g. Onset StowAway TidbiT Temperature Loggers

The Tidbit temperature logger is a completely sealed, small (~3 cm diameter) medallion like temperature logger. It is depth rated to approximately 300 m (1,000 ft.) and has an operating temperature range of -20° to +50°C. The tidbit uses optical communication via an Optical Base Station that plugs into a standard PC serial port. A total of three Tidbit temperature loggers were placed on the STRATUS 1 mooring line. In order to make a reliable comparison of performance all of the Tidbits were co-located with other temperature recording devices: one on the (IMET system #1) 1 m Sea Surface temperature module, one on the 10 m VMCM temperature sensor, and one on the 16 m SEACAT loadbar. The sampling rate was set to once every 30 minutes.

h. Vector Measuring Current Meters

The VMCM had two orthogonal cosine response propeller sensors that measured the components of horizontal current velocity parallel to the axles of the two-propeller sensors. The orientation of the instrument relative to magnetic north was determined by a flux gate compass. East and north components of velocity were computed continuously, averaged and then stored on cassette magnetic tape. Temperature was also recorded using a thermistor mounted in a fast response pod, which was mounted on the top end cap of the VMCM. The VMCMs were set to record every 7.50 minutes.

A new generation VMCM was deployed at the 350m depth on the STRATUS 1 discus buoy. It has all of the same components as the previous original VMCM but has a circuit board and flash card memory module. It can store up to 40 Mb of data on the flash card therefore the sampling rate was set to once per minute.

A total of 3 VMCMs were deployed on the surface mooring. All of the VMCMs had a compass spin performed at the dock in Arica to verify that the instrument was not damaged in transport.

i. Falmouth Scientific Instruments Current Meter

The 3D ACM, s/n 1325a, is an acoustic current meter on trial deployment from Falmouth Scientific Instruments, Inc. (FSI). The FSI current meter uses four perpendicularly oriented transducers to extract a single-point measurement. In addition to current values of north, east and up, the instrument also records temperature, tilt, direction and time. The instrument was set to record once every 30 minutes with an averaging interval of 450 seconds.

j. RDI Acoustic Doppler Current Profiler

An RD Instruments (RDI) Workhorse acoustic doppler current profiler (ADCP, Model WHS300-1, Serial number TSN-1218) was mounted at 135 m looking upwards on the mooring line. The RDI ADCP measures a profile of horizontal current velocities. The data sampling rates and parameters are user-definable, and were set as follows: 12 velocity bins of 10 m each, starting 11.98 m from the transducers and ending at 131.98 m; 30 pings per ensemble with one ping per second; and a 30-minute interval between the start of ensembles. These settings provided an approximately 400-day deployment lifetime on the internal battery. These particular settings are only available using the Windows version of the RDI deployment software (the DOS version limits you to 8 m bins). The time between pings must be set manually in the text-based deployment file before it is sent to the instrument.

k. Chlorophyll Absorption Meter

A WETLabs Chlorophyll Absorption Meter (CHLAM), model number 9510005, serial number ACH0126, was placed on the STRATUS 1 discus mooring at a depth of 25 meters. The CHLAM was mounted on a frame that fits inside a standard VMCM cage. A SeaBird pump drew water through a mesh filter and the CHLAM, and past two brominating canisters arranged end-to-end. Between samples, the bromide diffused through the system to reduce biofouling. Data were stored in a WET Labs MPAK data logger, serial number PK-023. The CHLAM/MPAK recorded a reference and signal from three optical wavelengths (650, 676 and 712 nanometers) and an internal temperature. The sample interval rate is 2 hours. At each sample, the pump is turned on for 10 seconds to flush the system. Ten seconds of sampling follow, with the 10-second average of signal and reference stored in the MPAK. The complete system was powered by two 10 D-cell alkaline battery packs and should last for approximately 400 days.

l. Acoustic Rain Gauge

An acoustic rain gauge from Jeff Nystuen at the Applied Physics Laboratory at the University of Washington was deployed on the STRATUS 1 mooring at a depth of 23.5 meters. This instrument uses a hydrophone and listens to ambient noise. Rain falling on the sea surface produces noise at certain frequencies, and these frequencies are sampled by this instrument. Data from the IMET rain gauges on the surface buoy as well as from the acoustic rain gauge can be compared.

m. Acoustic Release

On the STRATUS mooring there are 2 different acoustic releases. A primary release used for recovery of the mooring, and a secondary release used for test purposes. The primary release is an EG&G model 322 acoustic release. The Interrogate Frequency is 11.0 kHz. The Reply Frequency is 10.0 kHz. The codes are as follows: Enable=42, Disable=41, and Release=43. The test release is a Burn-wire Acoustic Release Transponder modified to be motor driven with a WHOI fabricated load bar. The Interrogate Frequency is 11.0 kHz. The Reply Frequency is 12.0 kHz. The codes are as follows: Enable=302632, Disable=302657, and Release=323616.

The test release has a titanium strength bar which was designed at WHOI. It was cut using a computer driven water jet. The strength member is rated for 60,000 lbs. This is being tested for the first time because the release mechanism on the BACS release can not handle the load it sees during the launch of the mooring and anchor drop. There is a piece of 1/2" trawler chain inside 2 " tygon tubing in parallel with the release. If the release fails or the strength member fails, the mooring will be held by the trawler chain. Then the recovery will be done with the primary release.

Table 5: IMET sensor specifications

Parameter	Sensor	Nominal Accuracy
Air temperature	Platinum Resistance Thermometer	+/- .25°C
Sea temperature	Platinum Resistance Thermometer	+/- .005°C
Relative humidity	Rotronic MP-100F	+/- 3%
Barometric pressure	Quartz crystal; AIR S2B	+/- .5 mbar
Wind speed and wind direction	R.M. Young model 5103 Wind Monitor	-3% (speed); +/- 1.5° (dir)
Short-wave radiation	Temperature Compensated Thermopile; Eppley PSP	+/- 3%
Long-wave radiation	Pyrometer; Eppley PIR	+/- 10%
Precipitation	R.M. Young Model 50201 Self-siphoning rain gauge	+/- 10%

The logger polls all IMET modules at one-minute intervals (takes several seconds) and then goes to low-power sleep mode for the rest of the minute. Data are written to disk once per hour. The logger also monitors main battery and aspirated temperature battery voltage.

The air temperature, sea surface temperature, barometric pressure, relative humidity, long-wave radiation and precipitation modules take a sample once per minute and then go to low-power sleep mode for the rest of the minute.

The short-wave radiation module takes a sample every 10 seconds and produces a running, one-minute average of the six most recent samples. It goes to low-power sleep mode between ten-second samples.

The vane on the wind module is sampled at one-second intervals and averaged over 15 seconds. The compass is sampled every 15 seconds and the wind speed is averaged every 15 seconds. East and north current components are computed every 15 seconds.

Once a minute, the logger stores east and north components that are an average of the most recent four 15-second averages. In addition average speed from four 15 second averages is stored, along with the maximum and minimum speed during the previous minute, average vane computed from four 15-second averages, and the most recent compass reading.

In addition, an IMET Argos PTT module is set for three IDs and transmits via satellite the most recent six hours of one-hour averages from the IMET modules. At the start of each hour, the previous hour's data are averaged and sent to the PTT, bumping the oldest hour's data out of the data buffer.

Table 6: STRATUS buoy tower sensor information.

Instrumentation mounted on 3 meter discus buoy

Parameter	Sensor ID	Sampling Rate/Record Rate	Elevation relative to buoy deck (meters)	Elevation relative to water line (meters)	Measurement location
IMET system 1	Logger 117				
Wind speed	WND 104		2.96	3.39	Prop axis
Wind direction	WND 104		2.96	3.39	Prop axis
Air Temperature	TMP 102		1.61	2.04	End of probe
Relative Humidity	HRH 108		2.31	2.74	Tip of sensor
Barometric Pressure	BPR 107		2.36	2.79	Center of port
Precipitation	PRC 102		2.71	3.14	Top of funnel
Long-wave Radiation	LWR 101		3.15	3.48	Base of dome
Short-wave Radiation	SWR 111		3.14	3.47	Base of dome
Sea Temperature	SST 003		-1.00	-0.57	End of probe
IMET system 2	Logger 226				
Wind speed	WND 105		2.89	3.32	Prop axis
Wind direction	WND 105		2.89	3.32	Prop axis
Air Temperature	TMP 104		1.59	2.02	End of probe
Relative Humidity	HRH 110		2.34	2.77	Tip of sensor
Barometric Pressure	BPR 106		2.40	2.83	Center of port
Precipitation	PRC 101		2.74	3.17	Top of funnel
Long-wave Radiation	LWR 106		3.15	3.58	Base of dome
Short-wave Radiation	SWR 109		3.14	3.57	Base of dome
Sea Temperature	SST 104		-1.00	-0.57	End of probe
Stand-alone Relative Humidity	HRH 204		2.32	2.75	Tip of sensor
Tid-bit Air Temp	358910		1.77	2.20	Tied to TMP 104
SBE-39 Floating SST	0072		surface	0	
Tid-bit Sea Temp	358909		-1.00	-0.57	Near SST 003
SeaCat Conductivity/ Temperature	1878		-1.00	-0.57	Center of cell

Table 7: STRATUS subsurface sensor information.

Instrumentation mounted on the mooring line of the 3 meter discus buoy

Instrument	Serial Number	Depth from Mooring Diagram (meters)	Sampling Rate/Record Rate	Parameter(s) Measured
SeaCat	1875	3.71	3.75 Min.	Temperature
	1873	7		
	2325	16		Conductivity
	1880	30		
Brancker T-Pod	3763	13	30 Min.	Temperature
	4491	35		
	3301	47.5		
	3831	55		
	3830	70		
	3764	77.5		
	3258	92.5		
	3263	100		
	4495	115		
	4485	145		
	4228	160		
	3836	220		
3259	250			
VMCM	VM038	10	7.5 Min.	East and North Currents
	VM037	20		
New Gen VMCM	VM01	350		
MicroCat	1328	40	3.75 Min.	Temperature Conductivity
	1326	62.5		
	1305	85		
	1330	130		
	1306	190		
SBE-39	0050	25 (on Chlam)	5 Min.	Temperature
	0048	349		
	0049	350		
Chlam	ACH0126	25	2 Hours	Chlorophyll-a
ADCP	TSN-1218	135	30 Min.	East and North Currents
FSI	1325A	235	30 Min.	East and North Currents
Tidbit	358909	(on bridle)	30 Mins	Temperature
	358907	10 (on VMCM)		
	358908	16 (on SeaCat)		
Acoustic Rain Gauge	F9	23.5		Precipitation

B. Shipboard Air-Sea Flux System

A sonic anemometer system for measuring turbulent wind flux (son-flux system) was mounted on the jackstaff on the bow of the R/V *Melville*. Jim Edson and Jon Ware developed the system at WHOI. The sensor consisted of a Gill R3A Ultrasonic Anemometer, a Crossbow DMU-AHRS motion sensing unit, and an Onset TT8 interface. From the sensor, a cable ran to an interface box in the lab which connected to a PC computer and two power supplies. The cable supplied power to the instrument and was used for continual real-time data uploading to the PC. Jon Ware and Ed Hobart developed the logging software (Son_flux) at WHOI. There are two calibration procedures for the DMU. The first, zeroing of the rate sensor while the ship is tied to the dock, was completed successfully. The second, a hard iron calibration that requires spinning the ship through 720° while underway, was not completed because the instrument timed out. The sensor's magnetic compass data can be corrected for this missing calibration after the cruise by using the ship's gyro compass data. The hard iron calibration constants were not set to zero until October 7, 2000 (see Appendix 7). The data files recorded by the Son_flux software are named DDDSSSS.C1 where DDD is yearday and SSSS is the time of day (UTC) in seconds when the data in the file begins. The data files from the cruise each contain 1 hour of data. Data recording began on October 2, 2000 before the R/V *Melville* left Arica, and continued until we returned to Chilean waters on October 13, 2000 with two breaks for hard iron calibration. See Appendix 7 for detailed timeline of data recording and calibrations.

C. Ancillary Shipboard Meteorological and Oceanographic Instrumentation

Following the deployment of a surface buoy, and prior to its recovery, the ship is positioned approximately 0.25 miles downwind of the buoy so that shipboard meteorological observations can be made and compared with the data collected by the buoy. While close to the buoy the Argos transmissions can be received, decoded, and compared with the shipboard observations. The comparison of data provides a means by which to confirm that the buoy-mounted sensors have not been damaged during deployment. Similarly, if a sensor is damaged during recovery, the sensor may not be able to be recalibrated. If accurate shipboard observations are made prior to recovery these observations provide a means by which to evaluate the sensor's performance at the end of the deployment. The comparison plots can be found in Section 3. This section includes a brief description of the instrumentation used in making the buoy/ship comparison and ancillary shipboard meteorological and oceanographic observations.

1. Meteorological Instrumentation Provided by Woods Hole Oceanographic

In order to obtain a good record of incoming longwave and shortwave radiation during the transits to and from the mooring site, additional sensors were mounted on the ship to complement the ship's IMET system. These were installed forward of the bridge on the O-3 level, clamped to the railing together with an ASIMET RH/Air Temperature module (Figure 9).

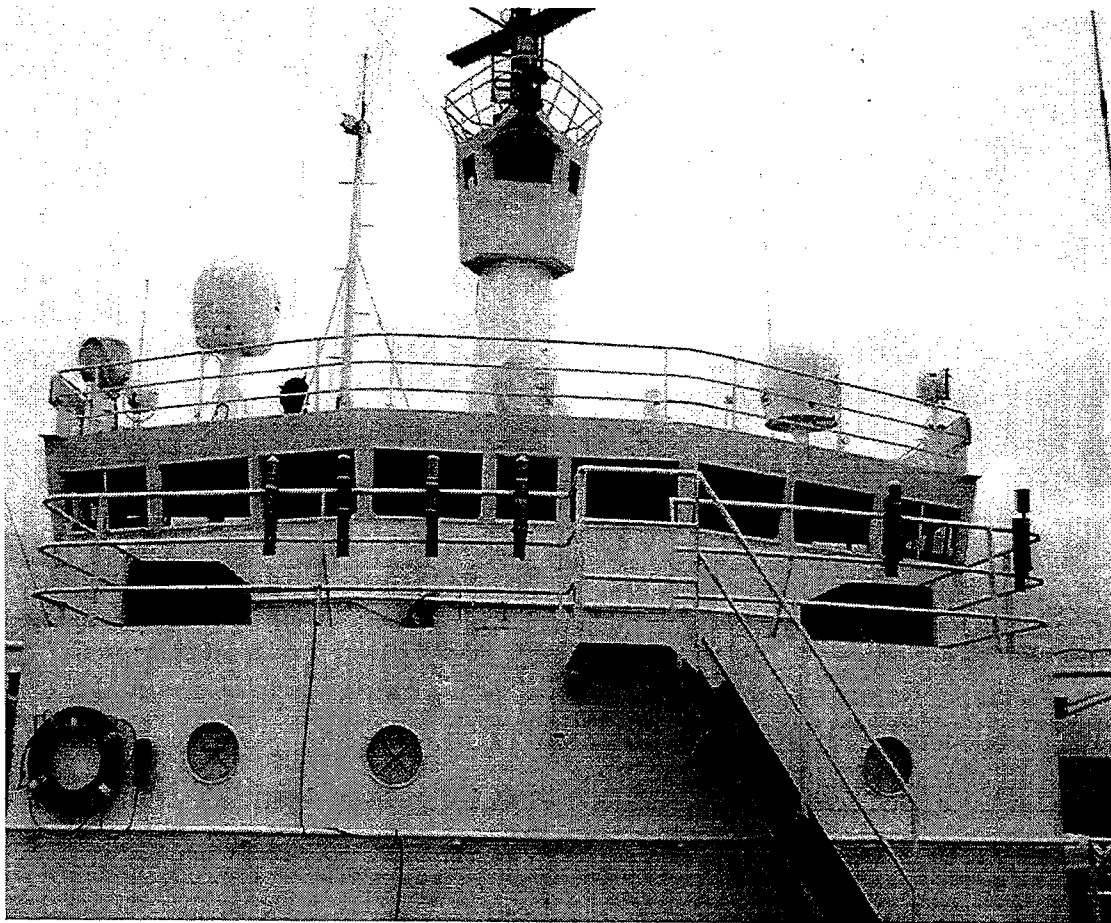

Figure 9: Location of the ASIMET Modules

a. ASIMET Relative Humidity/ Air Temperature Specifications

Relative humidity measurements are made with a Rotronic MP-101A Sensor. To meet the environmental needs of buoys and ships, the sensor is packaged in a custom housing which is more rugged than the standard housing and with high pressure water seals. The sensor electronics is conformal coated and the housing is sealed with desiccant packs to eliminate condensation. The humidity-temperature probe provides analog outputs of 0 to 1.0 volts DC for humidity (0 to 100% rh): and 0 to 1.0 volts DC for temperature (-40 to +50 deg. C). These signals are amplified and converted to digital within the module. One set of measurements are made every minute and calibrated via a fourth order polynomial for RH% and degrees C. This set of measurements is returned when polled. This probe is placed inside a modified R.M. Young multi-plated radiation shield. This modified shield has wider plate spacing and hydrophobic coating on the plates to provide a more accurate measurement.

b. ASIMET Short-wave Radiation Specifications

Short-wave radiation is measured with a modified Eppley Precision Spectral Pyranometer (PSP) mounted on a aluminum base which provides a reference mass for the PSP. The aluminum base is mounted to a PVC endcap for thermal isolation from the module housing. The sensor uses a temperature compensated thermopile. It provides an output voltage proportional to

incident short-wave radiation (0.3 to 5.0 micro meters). Sensitivity is approximately 9 micro volts per watt, per meters squared, and has a temperature dependence of +/- 1% over the range of -20 to +40 degrees C. A sample is collected, calibrated via a fourth order polynomial, and averaged for the returned measurement.

c. ASIMET Long-wave Radiation Specifications

Long-wave radiation is measured with a modified Eppley Precision Infrared Radiometer (PIR) sensor. Samples are recorded at a rate of 1 per minute. There are 3 temperatures measured, thermopile, dome temperature, and body temperature which are used in calculating temperature radiation compensation for sensor response. It provides an output voltage proportional to incident long-wave radiation (3.0 to 100.0 um). Sensitivity is approximately 5 micro volts per watt meter squared and temperature dependence is +/-2% over the range (-20 to +40 degrees C).

Table 8: Instrumentation mounted on 03 level on R/V *Melville*

Parameter	Sensor ID	Elevation to water line (meters)	Measurement location
Short-wave Radiation	SWR 208	12.54	Base of dome
Short-wave Radiation	SWR 211	12.54	Base of dome
Long-wave Radiation	LWR 207	12.55	Base of dome
Long-wave Radiation	LWR 206	12.54	Base of dome
Long-wave Radiation	LWR 001	12.62	Base of dome
Relative Humidity	HRH 207	12.58	Tip of sensor

2. Independent Meteorological Data Recording System (Shipboard)

An independent meteorological data recording system is permanently mounted on the bowmast of the *Melville* and is maintained by SIO. The package is built up from IME modules and contained wind speed and direction, air temperature, relative humidity, short-wave radiation, long-wave radiation and barometric pressure sensors. The air temperature sensor is a R.M. Young sensor that was last calibrated on 10 Aug. 2000. The relative humidity/air temperature sensor was a Rotronics MP-101A sensor that is aspirated to minimize the effect of solar heating. It was last cleaned and calibrated on 15 Aug. 2000. The sensor is the same as used in the IMET relative humidity module and the stand-alone relative humidity with temperature instrument. The wind sensor is an R.M. Young propeller anemometer, also used in the IMET wind module. It was last calibrated on 10 Aug. 2000. The short-wave sensor is a Precision Spectral Pyranometer (PSP) manufactured by Eppley Laboratory, which is the type used on the IMET system. Dome was last cleaned on 14 Aug. 2000, and sensor calibrated at Eppley on 19 July 2000. Long-wave radiation uses Precision Infrared Radiometer (PIR) (Eppley Laboratory), that is also used in the IMET buoy system. Dome was checked on 14 Aug. 2000. Sensor was found to be using an old set of calibrations, therefore a very small amount of drift may be included in the data. Barometric pressure is measured with a A.I.R type DB-2A. It was last checked and calibrated on 9 Aug. 2000. Data are obtained every minute by RS-485 and are made available on the ship's computer system.

3. FSI-OCM & FSI-OTM (Shipboard - Thermo-salinograph)

The FSI OCM (Falmouth Scientific Instruments - Ocean Conductivity Module) is used in conjunction with the FSI OTM (Ocean Temperature Module) to continuously record conductivity, temperature, and salinity during the outbound and inbound legs of the cruise. The sampling is done by pumping sea water through the modules via the uncontaminated sea water system. Uncontaminated seawater is provided by the pump in the bow dome at 50 gal/minute. The OCM was last calibrated on 10 Aug 2000. The FSI OTM was last calibrated on 19 July 2000.

4. Acoustic Doppler Current Profiler (Shipboard)

The RD-VM (RD Instruments - vessel mount) 300 kHz Acoustic Doppler Current Profiler (ADCP) employs the Doppler principle to remotely measure speed and direction of water currents from a moving vessel. By transmitting a succession of acoustic pulses, and segmenting the resulting backscatter echoes into many depth cells (bins) over a depth range of 30 to 700 meters, computer analysis of the bins provides a detailed profile of current speed and direction throughout the water column accurate to 1 cm/sec. In waters where the bottom depth is within range, the ADCP bottom track feature measures earth referenced vessel speed. Combination of these measurements yields absolute (earth referenced) vertical current profiles from a moving vessel without inputs from other navigation systems. The IBM XT/AT compatible computer based Data Acquisition System (DAS) processes the ADCP data in real time together with vessel attitude and heading data to produce vector averaged profiles in earth referenced coordinates. Processed and / or raw data is logged on hard disk. Data was also displayed in real time on the monitor screen.

5. Sea Beam 2000 (Shipboard)

The Sea Beam 2000 system, by Sea Beam, uses an array of 121 sensors (beams) that are mounted on the hull in alignment with the centerline of ship. It is a multi-beam echo sounder. The Sea Beam system was updated in 1993 when the R/V *Melville* underwent its major overhaul and extension. Side scan (4 bit-resolution) and depth were recorded on a plotter while the Sea Beam system was running. The Sea Beam is calibrated daily with a sound speed correction based on a daily 1500-meter XBT. The Sea Beam 2000 maps the sea floor as the ship steams in a swath where width is roughly 1/4 the water depth.

6. Knudsen 320 B/R (Shipboard)

The Knudsen single beam echo sounder 320 B/R uses 3.5 and 12 kHz frequency sound to measure distance to the ocean bottom. It measures the depth of the water by transmitting brief pulses of ultrasound downward toward the ocean bottom, and measures the amount of time it takes for the bottom echo to return. The intensity of the received signal as a function of depth is printed vertically on the graph recorder. During the Cook 2 cruise, only the low frequency sounder was used.

7. Shipboard Navigation Systems

An Ashtech 3DF differential GPS receiver is used to record the attitude, pitch and roll of the R/V *Melville*. It is permanently installed to provide the most accurate information. The Ashtech, along with GPS heading information, is passed to the ADCP for calculation of the current profiles. P-Code (decoded military GPS) and Trimble are used to calculate the position and speed that is displayed on the other shipboard instrument systems. The bridge uses the traditional type of ship navigation instruments including the Doppler Sonar Speed Log and a Gyroscope.

8. Gravimeter

The Bell BGM-3 gravity meter measures relativistic changes in the Earth's gravity field. This is used to analyze changes of density in the Earth's crust.

Section 3: Sampling During Transits and Buoy/Ship Comparison

A. Outbound

1. Underway Watch

In the direction outbound to the mooring site from Arica, the underway watch launched expendable bathythermographs (XBTs), made handheld observations of surface meteorology and cloud cover, and logged the ship IMET and thermosalinograph systems.

XBTs launches occurred every 30 minutes, nominally on the hour and half hour, from the aft starboard corner of the fantail. The models used were the Sippican T-7 and Sparton XBT-7, both logging to a nominal depth of 760 m. Approximately once a day, a FastDeep XBT from the ship's supply, logging to 1000 m, was launched instead in order to calibrate the SeaBeam system. In one instance a Sippican T-10, logging to a terminal depth of 200 m, was launched instead. A large number of the probes were quite old, and a high failure rate was anticipated. Fortunately, the vast majority of the probes worked with no apparent problems (see Appendix 2, Table 11). The most frequently encountered problem was softened wax in the launcher-loaded end of the XBT tube, making electrical contact between the launcher and the XBT difficult. This was overcome by cocking the gun quickly to pierce the wax, and by occasionally wiping the prongs in the launcher clean. Data for each XBT cast was stored in ascii (.edf) and binary (.rdf) format. The correct GPS location for the start of each cast is stored in the headers of the data file, though the time and date in the header information is incorrect. XBT launches were discontinued at the start of the bottom survey.

A bucket temperature was taken after each XBT launch, with the temperature read on a mercury thermometer in the third of a sequential series of catches, to allow the thermometer time to equilibrate. Along with this, a number of handheld and visual meteorological observations were made to build confidence in the ship IMET systems. These were: an infra-red skin temperature (IR) using a handheld probe pointed downwards about 30° away from the ship (Tasco THI-500), relative humidity (RH) and air temperature (AT) from a Vaisala handheld instrument (Vaisala HM 34), barometric pressure (BP — from an AIR barometer/altimeter set to pressure mode), and visual observations of both cloud cover and cloud type when possible. The bucket temperatures and handheld readings were made from just aft of the port hangar on the fantail of the ship, extending instruments into the airstream passing the ship.

The underway watch also hand-logged the display of the ship IMET and thermosalinograph systems every half hour, to build confidence that this data was being properly recorded. As the ship approached the mooring site and during the bottom survey, estimates of the ADCP near-surface (60 m depth) velocity were logged in order to build a rough map of current velocities for mooring deployment planning. The outbound underway watch was discontinued at the end of the bottom survey.

The handwritten logs were entered into an Excel spreadsheet file ('XBT/ship log' and 'Handheld Met log'), and imported into Matlab. These files are written with the raw XBT data files.

Three salinity samples were drawn from the ship's uncontaminated seawater tap (drawing from the same source as the thermosalinograph) for later autosal analysis on the outbound and inbound legs.

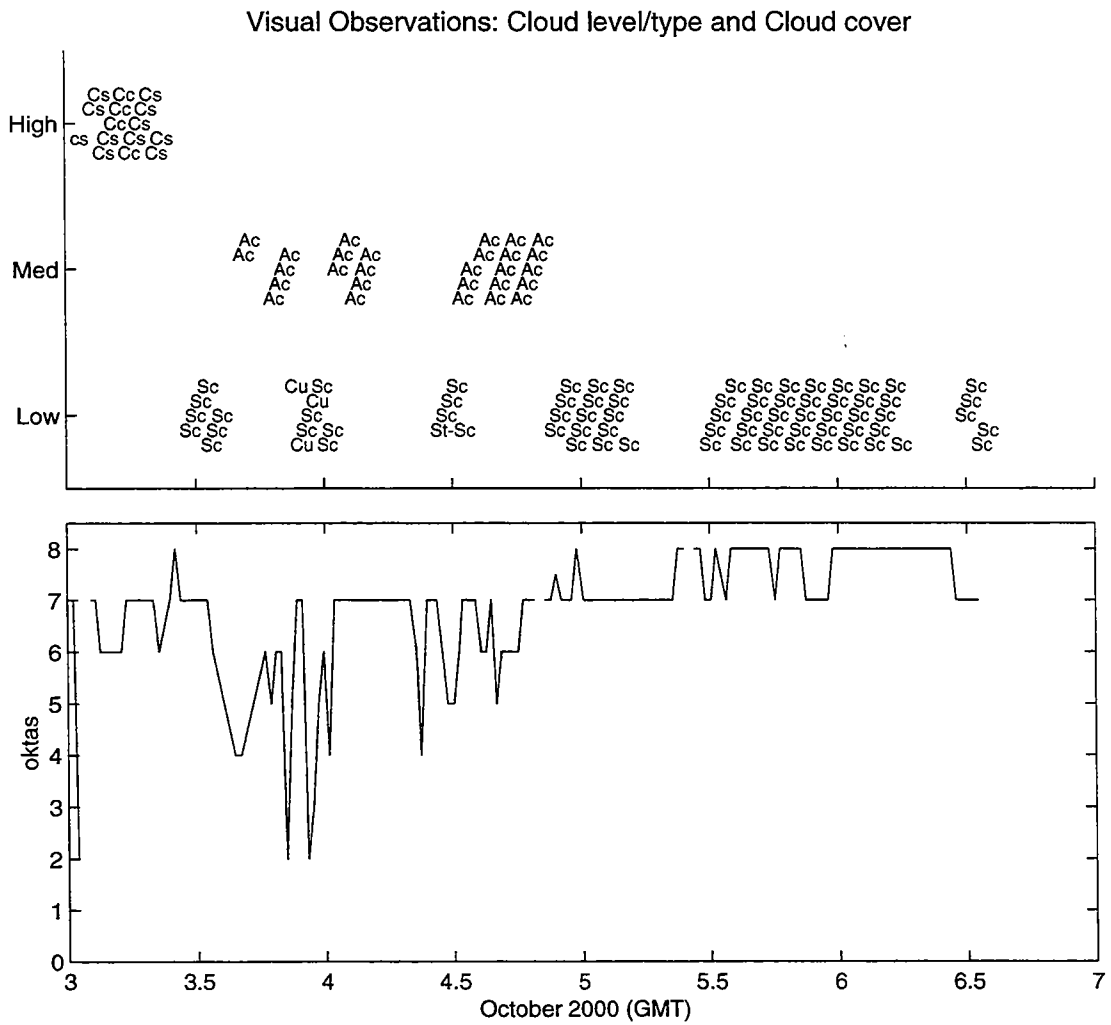

Figure 10: Visual observations of cloud type and cover made by the outbound underway watch.

2. XBT section

The outbound XBT section captured the upper ocean temperature structure at a high spatial resolution (averaging about 11 km). The station spacing and temperature contours displayed in Figure 11 and Figure 13 result from a rough data quality control, removing obviously bad XBT casts or portions of casts. Within several hundred kilometers of the coast, the mixed layers are quite shallow, generally less than 60 m deep. Further offshore and extending to the site of the mooring, the mixed layers gradually become much deeper, to well over 150 m

deep. Except for a swath nearshore (about 250 km wide peaking about 100 km offshore), surface waters were cooler when associated with shallow mixed layers, and grew warmer approaching the mooring site, where mixed layers were much deeper. The seasonal thermocline at the base of the mixed layer was quite sharp, with a temperature jump of over 3°C over several tens of meters. The seasonal thermocline had some depth variability suggestive of mesoscale eddies, sampled by a number of XBT stations (see particularly around 74.5 and 73°W), as did the permanent thermocline (with a very broad feature centered about 78°W).

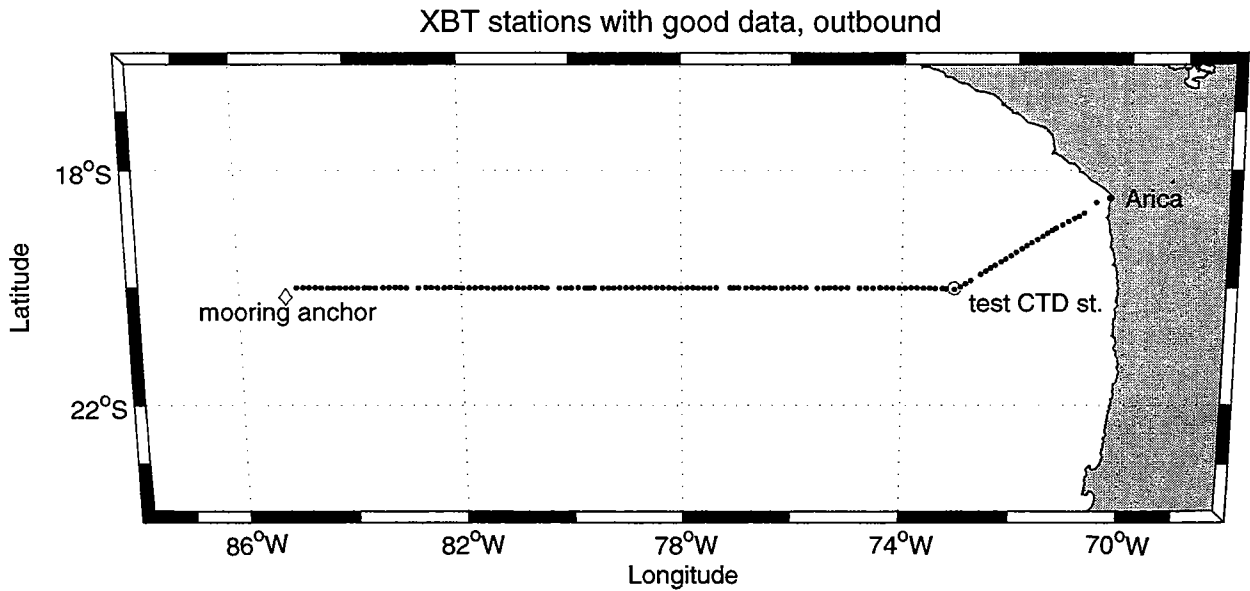

Figure 11: Location of XBT casts with good data in the outbound direction.

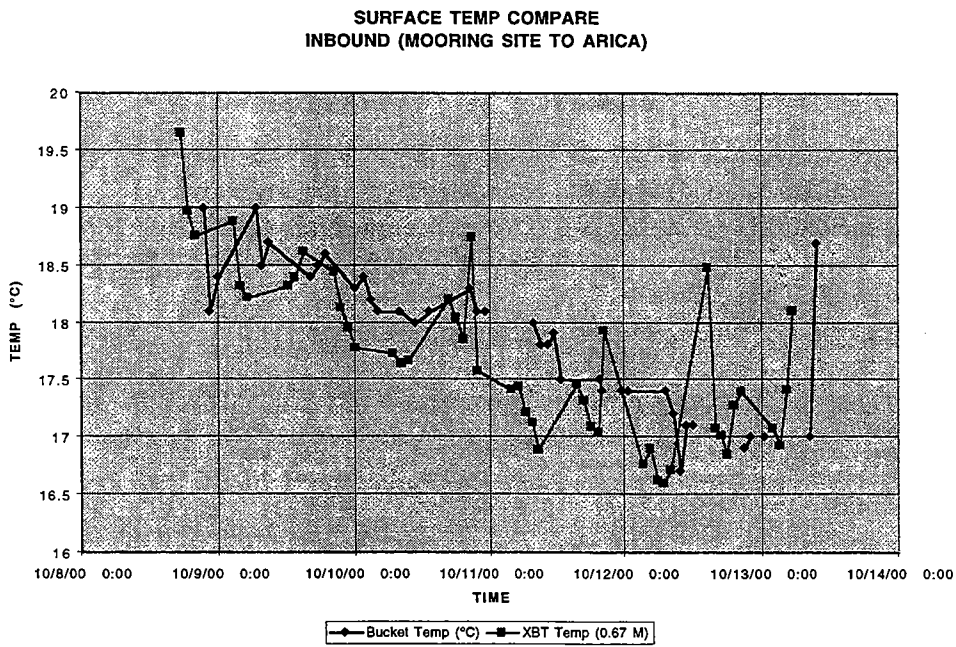
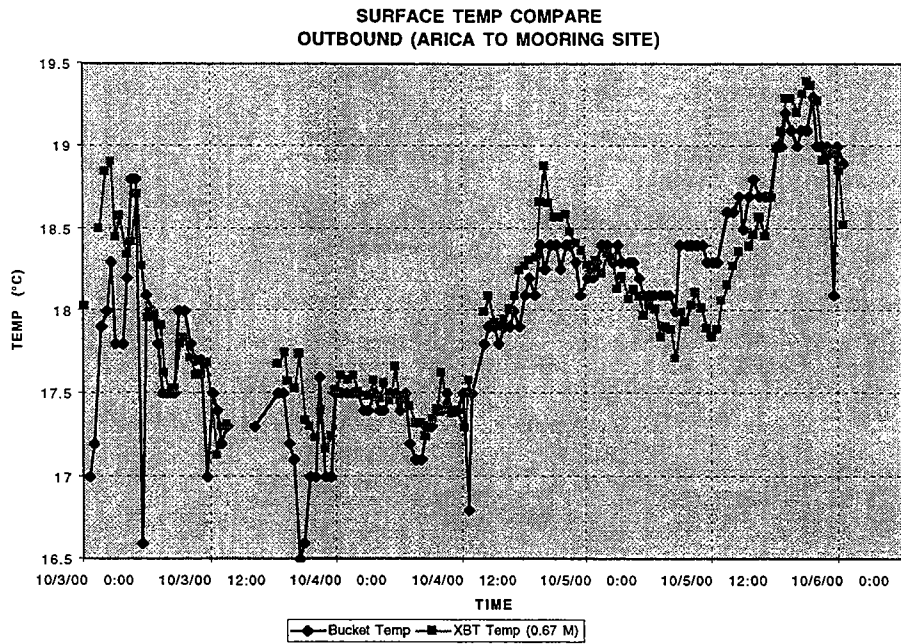

Figure 12: Sea surface temperatures from XBT casts (0.67 m) and bucket casts.

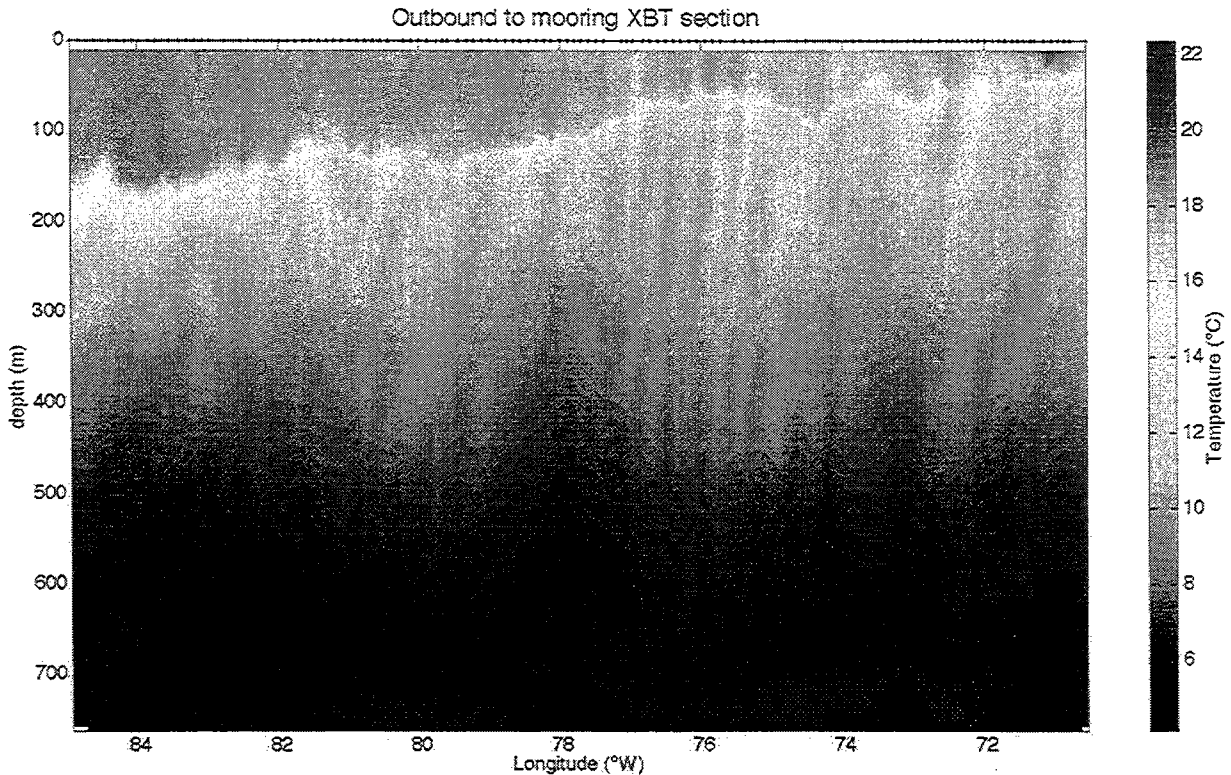

Figure 13: Contour plot of temperature from the good XBT stations in the outbound direction. Dots on the top x-axis mark the location of the included XBT casts. The top bound in temperature (above 22°C) is set by spikes in the near-surface temperature data visible near the coast.

3. Intercomparison of ship's sensors with handheld sensors

Comparison of the handheld meteorological data and ship IMET data gave us confidence that the ship IMET sensors were in reasonably good calibration and that electronic logging was working.

Figure 14 and Figure 15 show overplots of handheld, buoy, and ship IMET data. They generally show remarkably good agreement between the handheld readings and the ship met readings, and between ship and buoy readings (for those variables that location and tilt of the buoy on the dock or on the fantail of the ship does not affect the measurement).

Air temperature (top of Figure 14) has the worst correspondence between handheld and ship readings. Comparisons of the buoy temperature and handheld temperatures from the Vaisala sensor on the dock suggested a calibration problem with the handheld sensor. While on the dock and on the fantail of the ship, the buoy air temperatures show a more pronounced diurnal warming than the ship IMET sensors, but otherwise read about 0.7 °C lower, suggesting that the ship IMET air temperature sensor may have an offset calibration.

Both barometric pressure and relative humidity (middle and bottom of Figure 14) show good agreement between handheld, ship, and buoy readings, both while underway and at the dock before sailing. Handheld readings of barometric pressure were slightly higher (by about 0.5 mb) than the ship IMET sensor. Since the buoy transmissions are only integer values of barometric pressure, it is impossible to compare the sensors to that level of accuracy, but the atmospheric tidal signal is reproduced in all three records.

The ship thermosalinograph temperature (top of Figure 15, and valid only when the flow past the sensor, bottom, is nonzero) and bucket temperature measurements are in good agreement, particularly after one day underway when watchstanders had received some practice in taking the bucket temperature. The IR skin temperature was always equal to or below the bucket and ship T/S temperatures.

Sea surface salinity measured by the ship's thermosalinograph was not independently measured before the buoy deployment (except for by autosal analysis) and the rest of the meteorological measurements (long-wave and short-wave radiation, precipitation, and wind speed and direction) though recorded by the buoy were affected by the tilt of the sensors until deployment. Despite mild misting rain observed on several occasions, the ship precipitation sensor showed a continuous evaporation.

In all cases, the hand-recorded output of the ship IMET and thermosalinograph corresponded exactly to the file output (within the error imposed by typos). With good agreement between handheld and ship sensors (except for the small discrepancy suggested in air temperature, with the handheld sensor suspect), handheld meteorological measurements were halted at the start of the bottom survey.

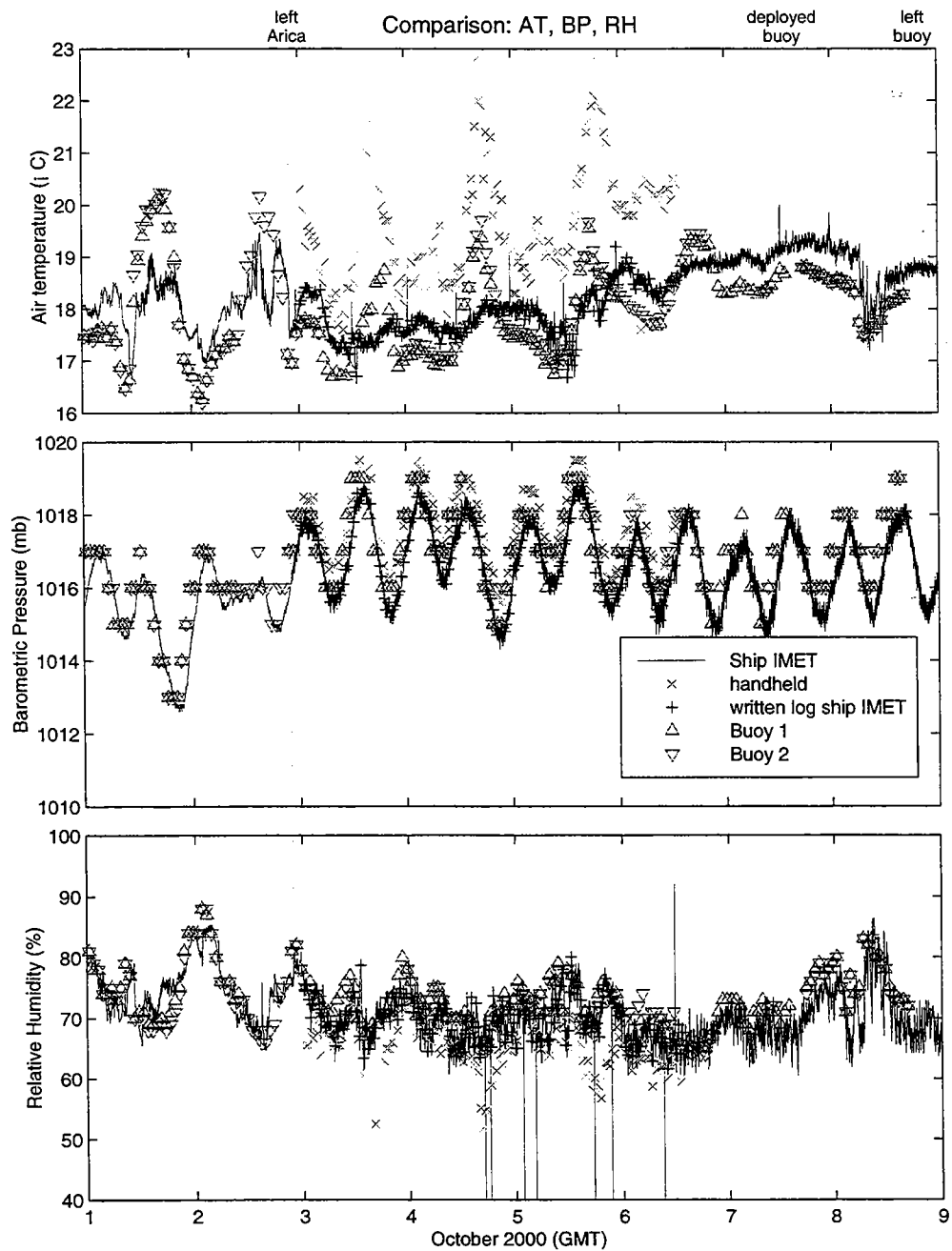

Figure 14: Overplots of Ship IMET, Buoy IMET, handheld, and written ship logs of air temperature, barometric pressure, and relative humidity.

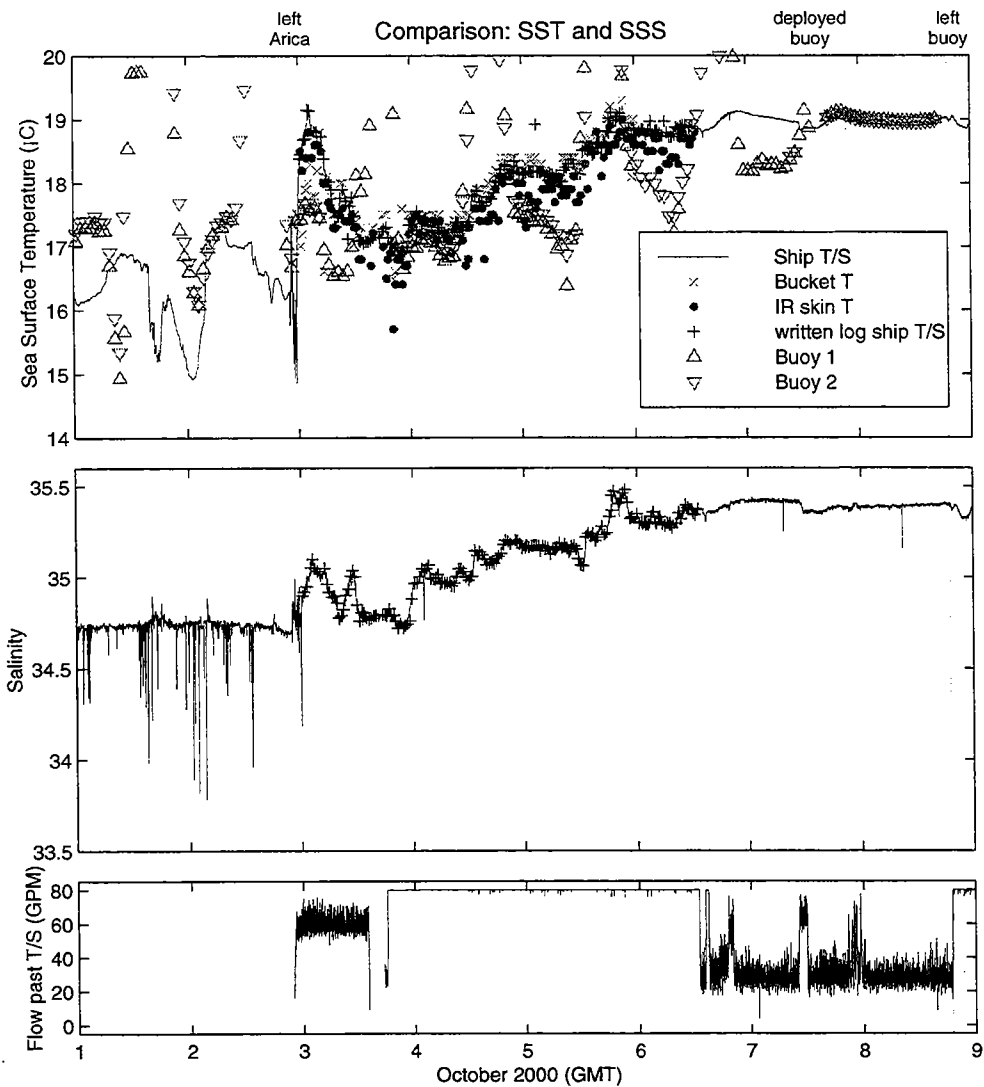

Figure 15: Overplots of Ship IMET, Buoy IMET, handheld, and written ship logs of sea surface temperature and salinity from the ship's thermosalinograph. The last plot is of the flow past the thermosalinograph, verifying that the pump was on while on station.

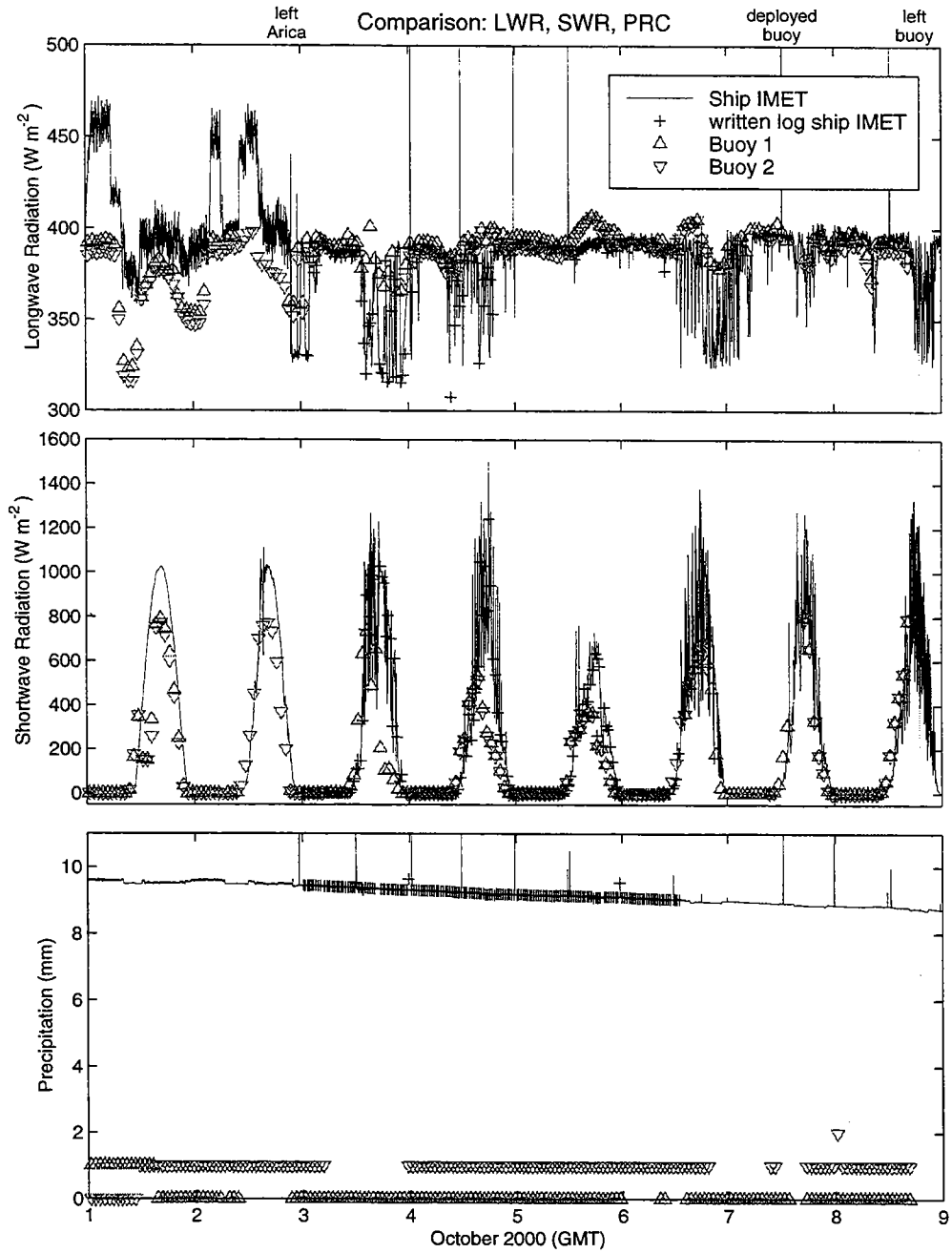

Figure 16: Overplots of Ship IMET, Buoy IMET, handheld, and written ship logs longwave and shortwave radiation, and precipitation.

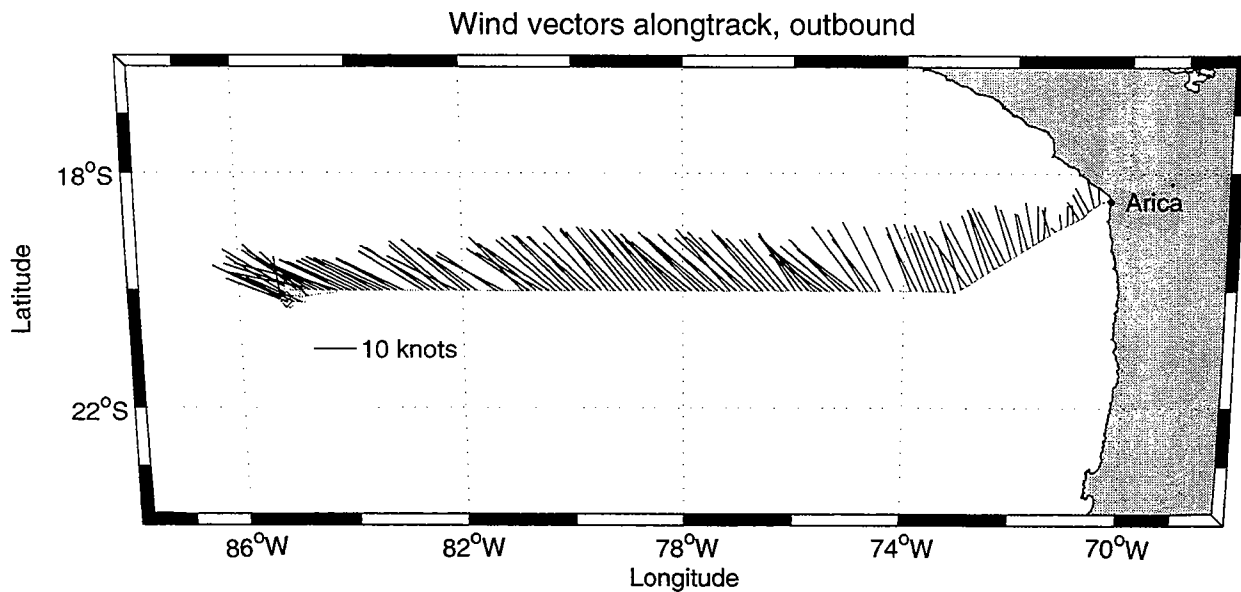

Figure 17: Alongtrack wind vectors calculated from the ship's IMET and GPS sensors, averaged every 30 minutes.

Alongtrack wind vectors were calculated from the ship's IMET winds (which measured relative to the moving platform of the ship) and heading and speed estimates based on ship GPS fixes in the IMET file (Figure 17). A more careful future analysis should use ship's heading information from the ship navigation system. The SE trade winds dominate the wind field from Arica out to the mooring site, with an increase in the winds as the ship moved offshore and to the west-southwest.

4. Intercomparison of Buoy and Ship IMET sensors after deployment

The ship IMET system is described in Section 2-C. After deployment of the surface mooring, the ship was held approximately 0.25 miles downwind, and a comparison of the shipboard meteorological and buoy sensor measurements was made. Figure 14, Figure 15, and Figure 16 show the period of time that the ship was on station near the buoy. Keeping in mind the differences noted in the section above (ship air temperature tends to read 0.7°C high, and ship barometric pressure about 0.5 mb low), a comparison shows that virtually all the sensors on the buoy were returning good values.

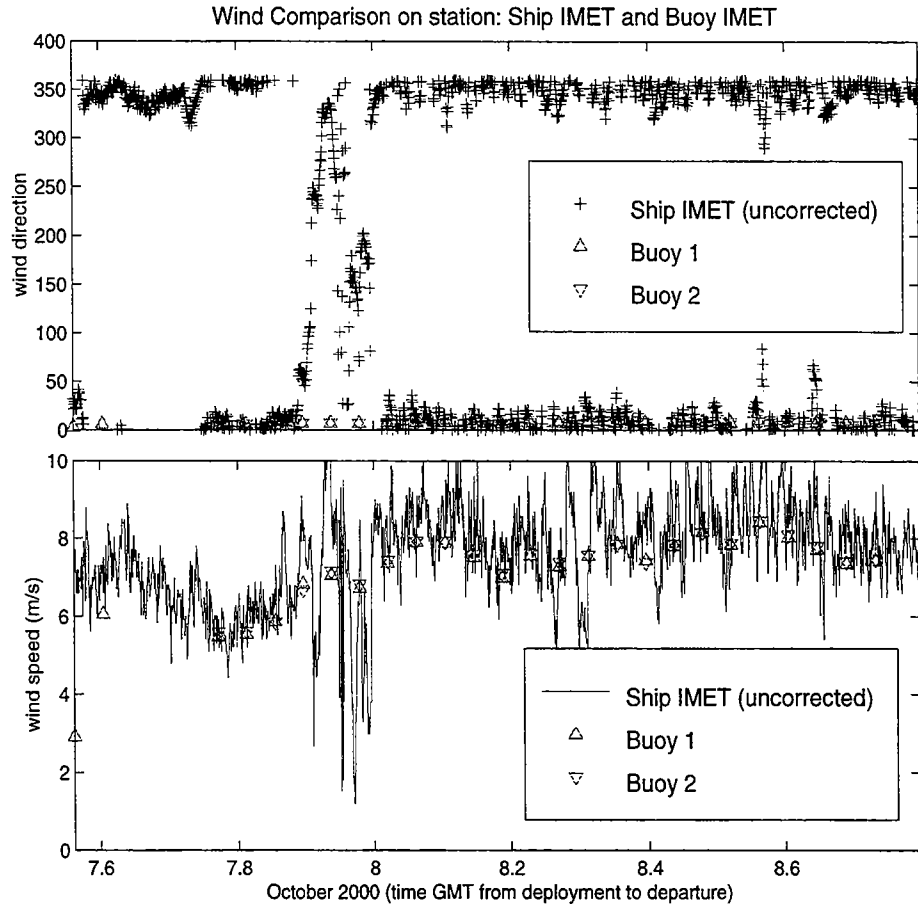

Figure 18: Comparison of ship IMET wind speed and buoy IMET wind speeds while on station after the buoy deployment. The time axis extends from the time of deployment to the time the ship left its monitoring station, 0.25 miles downwind of the buoy. Ship IMET wind speed is uncorrected, but the ship was holding station during this time.

B. INBOUND

1. XBT/CTD section

Watches resumed shortly before departure from the mooring. In conjunction with an inbound CTD section, XBTs were launched every 0.25 ° in longitude alongtrack (when not on CTD station), all Sippican T-7s or Spartan XBT-7s with terminal depths of 760 m. Bucket temperatures were taken with all XBT stations. Since the handheld and ship IMET meteorological measurements were in good agreement, the handheld measurements were discontinued.

Starting at 71°W and eastwards towards the 12 mile Chilean territorial zone, the XBT drop rate was increased significantly to capture details of the coastal upwelling. Two additional salinity samples from the ship's uncontaminated seawater tap (drawn from the same source as the ship's thermosalinograph) were taken. Results of the analysis of these water samples were not available in time for the publication of report.

For the hydrographic stations a SBE911+ CTD installed in a water sampling rosette was used. The rosette carried 24 sample bottles holding about 12 liters each. The CTD was equipped with two sets of pumped temperature and conductivity sensors, a fluorometer, an oxygen sensor, a light transmissiometer and an altimeter. Temperature and conductivity sensors were calibrated before the cruise by Seabird.

A total of 13 hydrographic stations were taken during Cook2, starting at the deployment site of the mooring (20° 09.508'S 85° 08.878' W). The transect was carried out along 20°S until 71°W, just east of the trench, covering the eastern part of the Peru Basin and the northern part of the Chile Basin, resulting in a station spacing of nearly 1° of longitude. All stations were sampled from surface to bottom, besides the trench station (Station 12) due to depth limitations of some of the sensors. During the upcast water samples were drawn for calibration purpose, and for chemical and biological analysis. A listing of the hydrographic stations is presented in Table 9. In between stations, XBT profiles down to 750 m were carried out each 15' of longitude. Table 10 lists the inbound XBT profile locations.

The hydrographic data were processed according to standard procedures (with SBE Seasoft routines) and were averaged to a bin-size of 1 db. Profiles of temperature, salinity and potential density for all stations are shown at the end of this section together with temperature and salinity sections along the transect.

From surface to bottom basically 5 water masses can be identified: Subtropical Water (Mixed layer with the highest temperatures and salinities), Subantarctic Surface Water (a thin layer below the mixed layer characterized by an upper salinity minimum), Equatorial Subsurface Water (a layer of 300-400 m with an intermediate salinity maximum and very low oxygen concentrations), Antarctic Intermediate Water (intermediate salinity minimum between about 500-800 m), and Pacific Deep Water (with decreasing temperatures and increasing salinities towards the ocean floor).

Parallel to the R/V *Melville* transect, two further transects were carried out by R/V *Vidal Gormaz*, along 27°S and 33°S at about the same time in 2000. All transects together will be analyzed with respect to water masses, geostrophic currents and the extent of the Oxygen Minimum Zone, and will be contrasted to WOCE transects within the southeast Pacific Ocean obtained during the early 1990's.

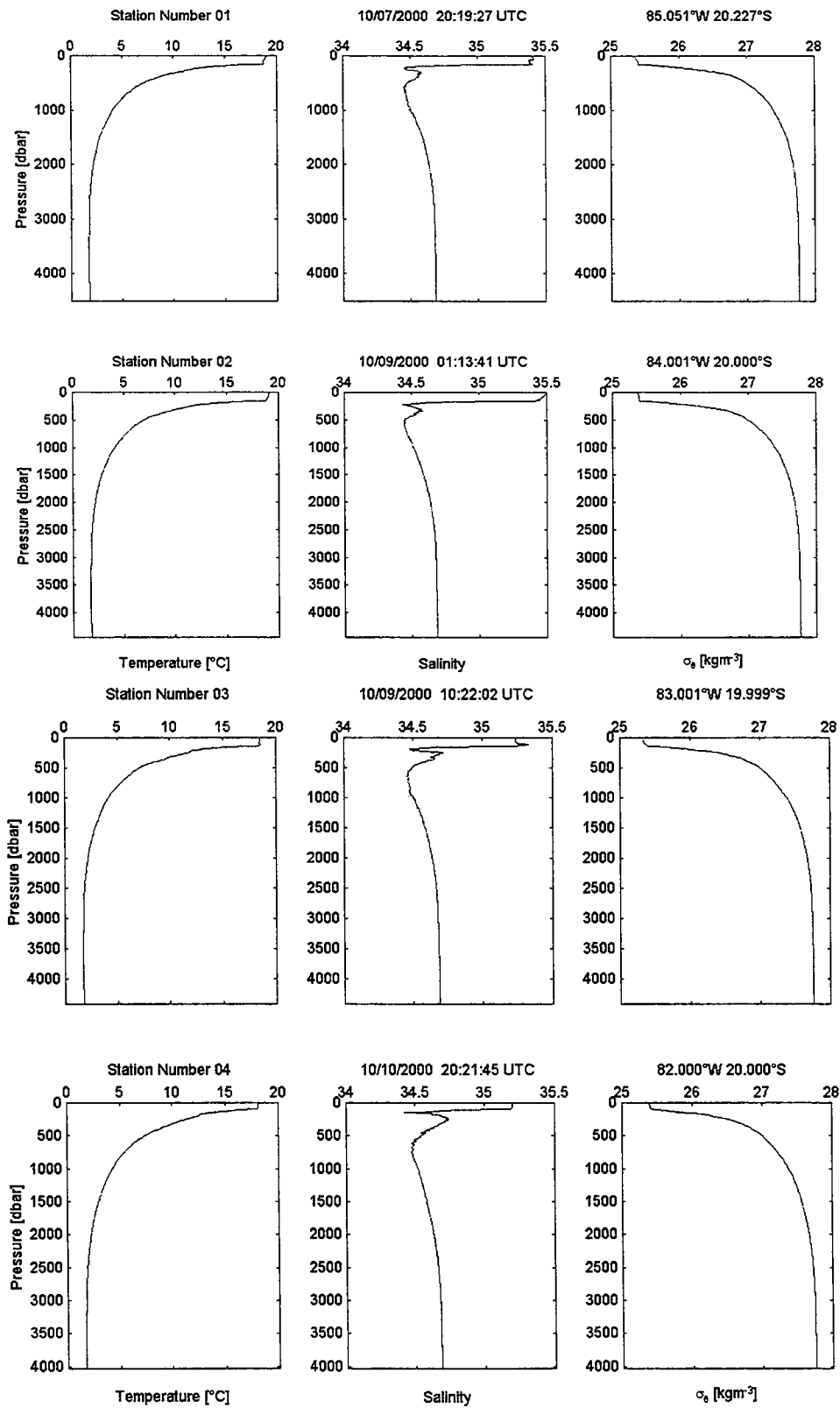

Figure 19: CTD stations one, two, three and four.

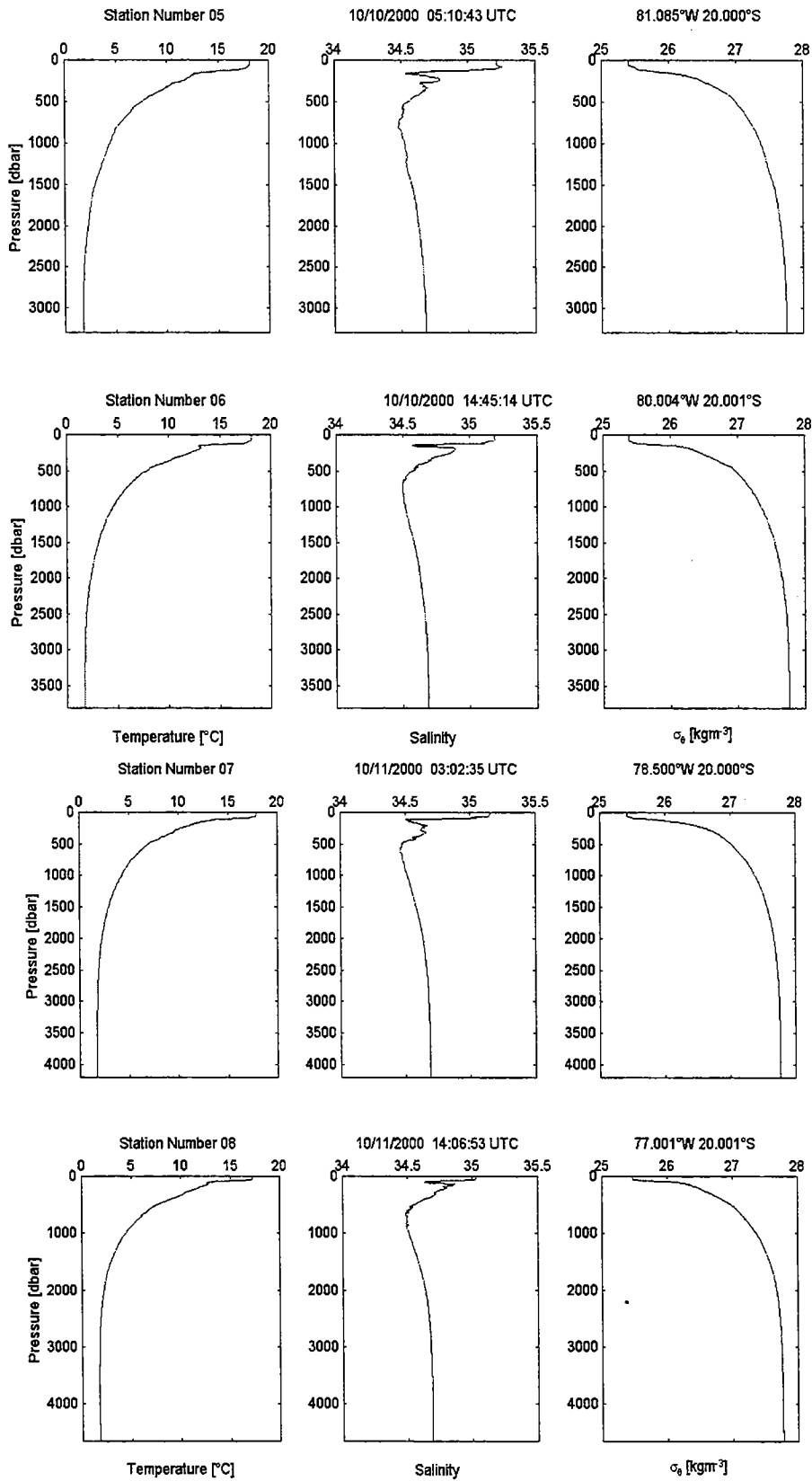

Figure 20: CTD stations five, six, seven and eight.

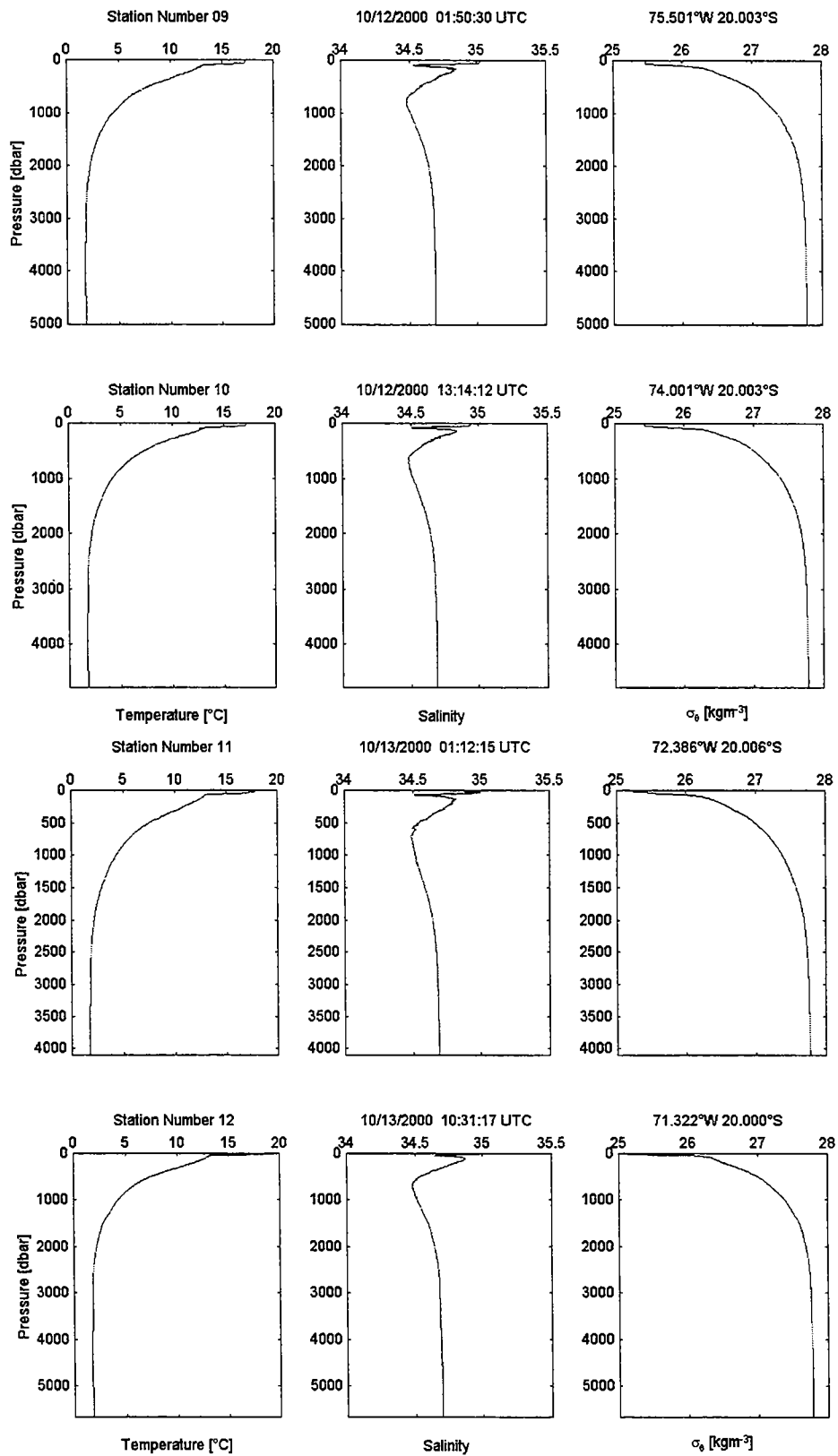

Figure 21: CTD stations nine, ten, eleven and twelve.

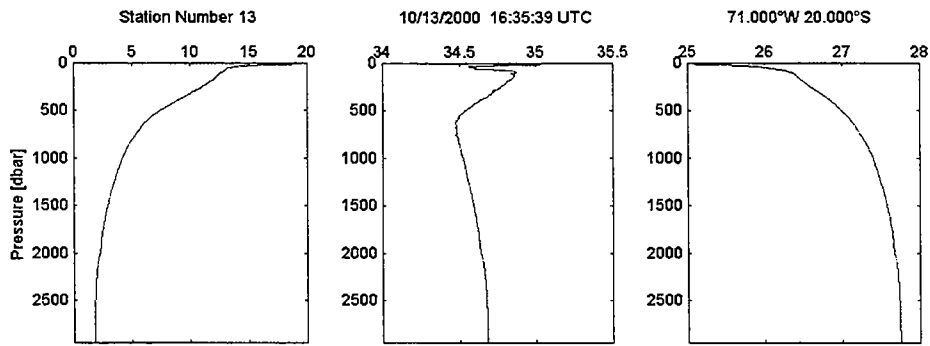

Figure 22: CTD station thirteen.

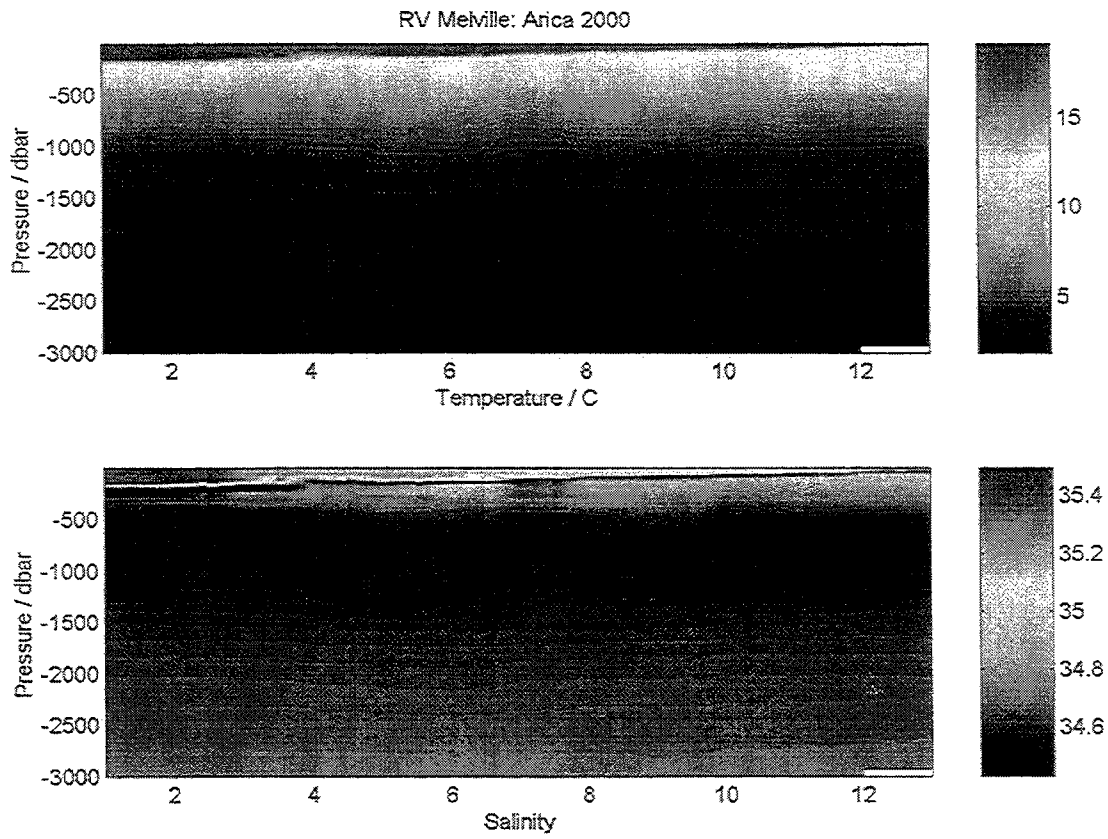

Figure 23: Inbound CTD transect profile.

Table 9: CTD locations and times.

Station N°	Date	Start Time [UTC]	Start Latitude [dd°mm.mm']	Start Longitude [ddd°mm.mm']	Depth [m]
1	00-10-06	20:20	20° 13.64'S	085° 3.07'W	4459
2	00-10-09	01:22	19° 59.99'S	084° 0.07'W	4365
3	00-10-09	10:22	19° 59.95'S	083° 0.06'W	4379
4	00-10-09	20:19	19° 59.97'S	082° 0.44'W	4006
5	00-10-10	05:12	19° 59.99'S	081° 0.05'W	3300
6	00-10-10	14:44	20° 0.08'S	080° 0.23'W	3793
7	00-10-11	03:05	20° 0.01'S	078° 30.02'W	4190
8	00-10-11	14:04	20° 0.04'S	077° 0.08'W	4607
9	00-10-12	02:00	20° 0.20'S	075° 30.05'W	4980
10	00-10-12	13:16	20° 0.25'S	074° 0.06'W	4742
11	00-10-13	01:18	20° 0.33'S	072° 23.17'W	4043
12	00-10-13	10:31	20° 0.02'S	071° 19.31'W	5500
13	00-10-13	16:35	20° 0.0'S	071° 0.00'W	3006

Table 10: Sampling at each location

Station N°	Bottles Fired	Pigments	Nutrients	Dissolved and Particulated ATP	Amino-acids	Oxygen	Bacterial Abundance Biomass Biovolume	POC/DOC
1	12	✓	✓	✓	✓	✓		
2	23	✓	✓	✓	✓			
3	24	✓	✓	✓	✓	✓		
4	24	✓	✓	✓	✓			
5	23	✓	✓	✓	✓			
6	12	✓	✓	✓	✓	✓		
7	12	✓	✓	✓	✓			
8	12	✓	✓	✓	✓	✓		
9	12	✓	✓	✓	✓			
10	12	✓	✓	✓	✓	✓	✓	
11	12	✓	✓	✓	✓		✓	
12	24	✓	✓	✓	✓	✓	✓	✓
13	12	✓	✓	✓	✓			

Section 4: Cruise Chronology

The buoy, meteorological and oceanographic equipment, mooring hardware, and related gear were shipped to the port of Arica, Chile in August 2000. Prior to this, the oceanographic and meteorological instrumentation had been tested and calibrated at WHOI. Further, the IMET meteorological instrumentation had been mounted to the buoy and that buoy included in an intercomparison on the beach with similar meteorological instrumentation from NOAA PMEL and JAMSTEC. In conjunction with that intercomparison the entire buoy had been rotated through 360°, stopping every 90° to record measured heading against true heading in order to quantify the uncertainty in measured wind direction due to the anemometers' compasses. See Section 2 for detailed results of the pre-deployment buoy spin.

Preparations in Arica were done in front of a warehouse at the Peruvian section of the port of Arica, Chile. This work was done in the last week of September 2000. The buoy meteorological instrumentation and telemetry of the meteorological data were checked out, and all VMCMs, Brancker temperature recorders (TPODS), SEACATs, micorCATS, SBE39s, Tidbits, and other instruments were prepared. On September 29, 2000, the *R/V Melville* arrived from its previous leg. Loading of the equipment began on September 30. The ship departed Arica on October 2 at ~1800 hours local.

From Arica, the ship steamed southwest to cross the coastal currents at a right angle. On the way out of Arica the ship executed two 720° turns in order to carry out a calibration of the compass in the air-sea flux system. Underway watch started at 1600 local, but no observations were made until the ship was outside the 12 mile limit in accordance with the clearance granted by the Ministry of Foreign Relations of the Republic of Chile. Once 20°S latitude was intersected the ship headed due west along 20°S. While underway to the site, preparations were carried out for the mooring deployments. These included familiarization of the science party with the operation of the mooring winch, with the handling of lines, and with the basic safety issues.

The underway watch took XBTs, bucket temperatures, and hand held meteorological observations and also manually recorded data from the ship's IMET and thermosalinograph. This was done on the leg outbound to the mooring site to carry out a comparison of the ship's underway systems in advance of using it to check the performance of the surface mooring once it was deployed. The results of the underway sampling on the outbound leg are presented in Section 2. At ~1000 local on October 3, the three releases were tested on the hydrographic wire at several depths down to 1,000 m. The WHOI SeaBird SBE-19 CTD was deployed on the same wire as a test. This was followed by a 200 m profile with the ship's CTD and rosette to confirm its operation.

Arriving at the nominal site for the mooring (85°W, 20°S) at 1900 local on October 5, the first activity was a survey of the bottom (Figure 24). This was done using the ship's SeaBeam to find and map the relatively flat (within ~100 m) section of bottom needed for deploying the mooring and to identify the depth of the water at the mooring so that the final splice in the adjustable section of the mooring could be completed. In the southwestern sector of the survey, a flat section with a depth of ~4450 m was found that was roughly 10 miles long and 4 miles wide (Figure 25).

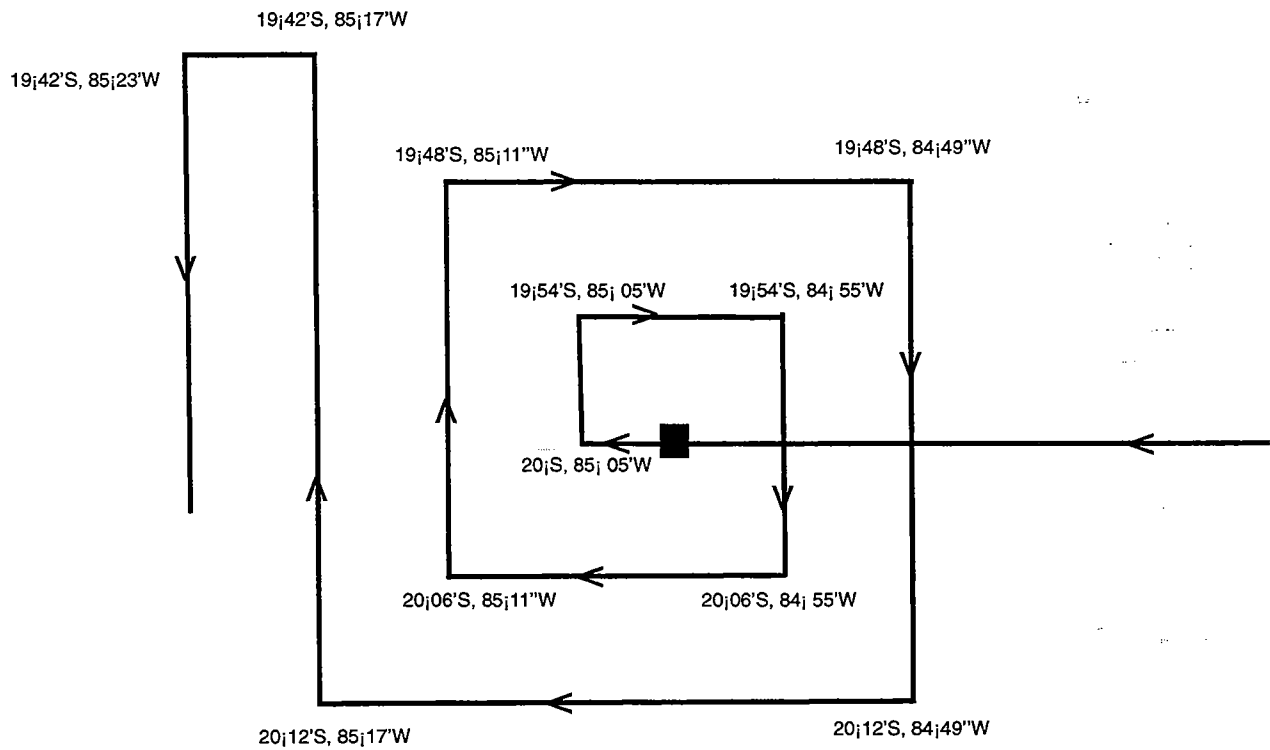

■ target for mooring 85° W, 20° S

Figure 24: Course track for carrying out the bottom survey using the SeaBeam on October 5-6, 2000.

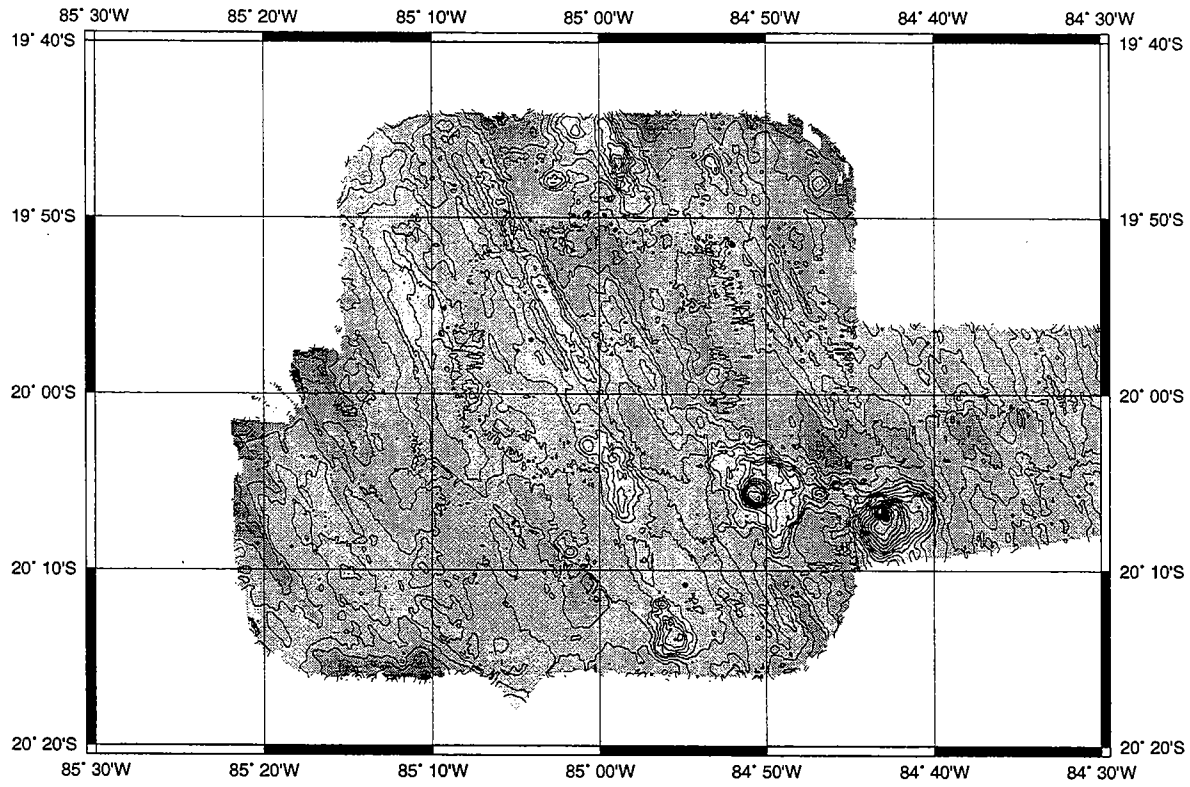

(Provided by Barry Eakins, SIO)

Figure 25: Contour plot of the bottom topography mapped during the survey.

The prevailing winds were from the east-southeast, and much of the time a northward current of 10 to 25 cm s⁻¹ was seen in the vicinity of the mooring site. To accommodate these conditions, to use the wind and current to carry the surface buoy away from the ship, and to be able to steam a course over the target region with the mooring trailing straight behind the ship, a path to the east-southeast over the flat bottom was chosen. The initial point of the track was (20° 07'S, 85° 12.5'W) and the final point was (20° 13'S, 85° 04'W). The final point was 10 nm away from the initial point. On October 6, the mooring was wound onto the TSE winch and final preparations made to the instrumentation, including application of antifouling paint, and grease to the ADCP transducer heads. (The CHLAM was started the morning of the 7th.) While these preparations were underway, a trial approach along the chosen track was made while resurveying the bottom. An initial speed of 1/2 knot through the water was successfully maintained, and the remainder of the bottom along the line was resurveyed at 5 knots. This confirmed that the mooring could be deployed in 4450 m ± 50 m of water anywhere along the track after moving approximately 4 miles down the track from the initial point. The Sea Beam was using a 1,000 m XBT for sound speed correction. The single point Knudsen depth recorder agreed with the SeaBeam once a 9 m depth correction from the Matthews Tables (region 42) was applied. Following this trial run and resurvey, a deep CTD was done with the ship's CTD. This would serve as the first station of the XBT/CTD section to be made inbound from the mooring site.

The deployment began with staging the instrumentation on deck at 0530 hours local on October 7. The attaching of instruments to the buoy and lowering them over the side began at 0800 with the ship holding its heading into the wind at the initial point. The deployment lasted until ~1600 hours local. The anchor was dropped at 1543 hours local (2043 UTC) on October 7, 2000 at 20° 09.508' S, 85° 08.878' W. Following the anchor drop, an acoustic survey of the anchor position was carried out. Figure 26 shows the track during the mooring deployment relative to the target track line as well as the ship's maneuvering during the acoustic survey and the subsequent day spent next to the surface buoy. Following the acoustic survey the releases were disabled. The anchor location was identified as 20°09.508'S, 85°09.073'W, approximately 5.9% of the water depth away from the anchor drop site. Alongside the buoy, Sea Beam gave a water depth of 4440 meters (Figure 27).

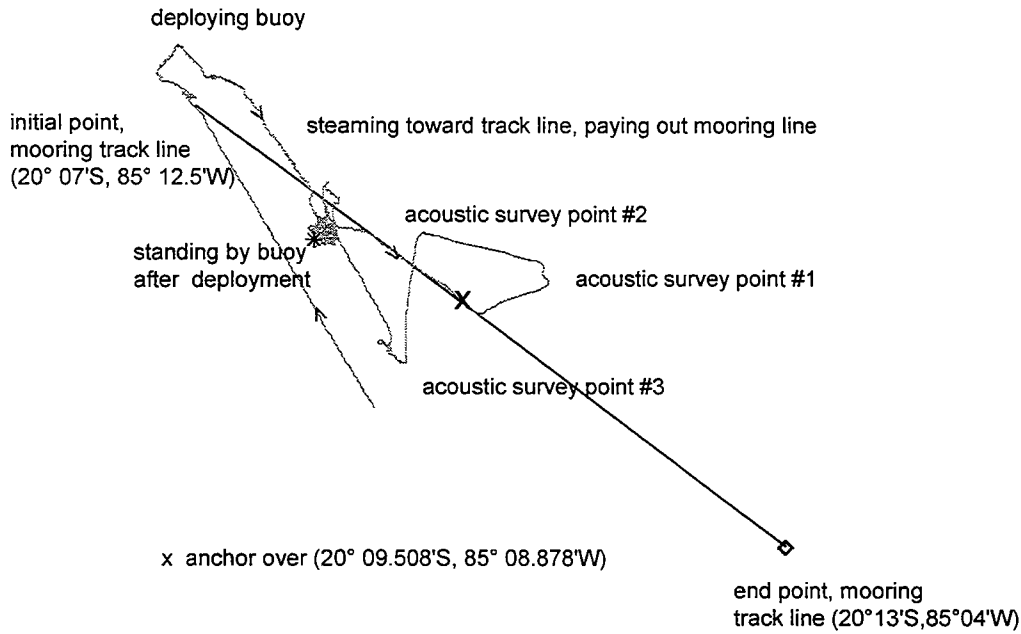

Figure 26: Target track path (black line) and ship's track (green) recorded by GPS during the mooring deployment, the acoustic survey of the anchor position, and the subsequent occupation of a position 1/4 mile downwind of the surface buoy.

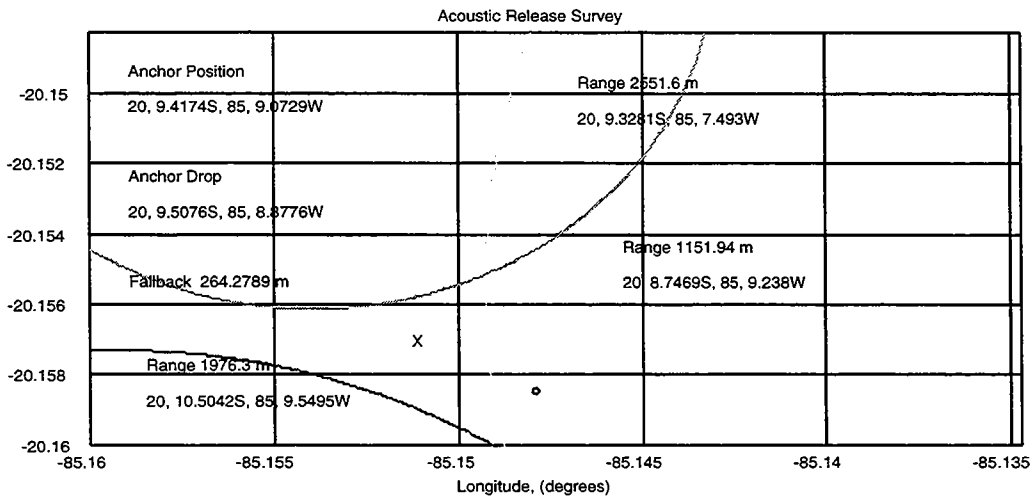

Figure 27: Figure showing the intersection of three horizontal range arcs based on slant ranges obtained at three survey points. The small blue circle is the position at which the anchor was deployed and the X marks a best estimate of the position on the bottom of the anchor.

After the anchor survey, the ship was positioned roughly a quarter of a mile downwind for a 24-hour comparison of ship and buoy meteorological sensors. On October 9 conditions were too rough to launch a small boat, so a close approach to the buoy was made with the ship to observe the functioning of the floating SST sensor and to gauge the mean waterline of the buoy. Shortly after, a piece of yellow plastic was observed in the water. Upon recovery, this was found to be a portion (~1/8 of one side) of a yellow hardhat from a glass ball, suggesting one ball had imploded upon deployment. Telemetry from the buoy was received directly and by e-mail from WHOI, and all indications were that the IMET systems were functioning well and the buoy holding on station. At 1400 local on October 8, R/V *Melville* departed the mooring site, sailing eastward along 20°S.

The underway watch was restarted at 1200 local. The handheld meteorological observations and manual logging carried out on the outbound leg were not repeated. Steaming east along 20°S, CTD stations were made every degree of longitude. XBTs were dropped every 15' of longitude in between. and the ship left to begin the passage back to San Diego. The ship was unloaded on May 5 and 6, 1997 and the gear shipped back to WHOI. The results of the inbound sampling are discussed in Section 2.

At 0800 local on October 14, 2000, R/V *Melville* docked in Arica. Unloading was completed on October 15.

Note: From The start of the cruise until 0200 local on October 5, local=UTC-4. To accommodate the shift in sunrise/sunset due to moving west, at 0200 local on October 5, the clocks were retarded and local = UTC-5.

Acknowledgments

The captain, Eric Buck, and crew of the R/V *Melville*, and the Resident Marine Technician, Ron Comer, and Computer Technician, John Chatwood, deserve special thanks for their hard work and dedication in making Cook 2 a total success. The facilities support staff and the shops at WHOI, especially the Mooring and Rigging shop, and their personnel are due much credit for the purchasing, design, fabrication, preparation, and shipping of all the equipment deployed and used on this cruise. Members of the Mooring and Rigging shop were essential to this effort.

This work was supported by the National Oceanic and Atmospheric Administration Grant No. NA96GP0429

References

- Trask, Richard P., Bryan S. Way, William M. Ostrom, Geoffrey P. Allsup, and Robert A. Weller, 1995. Arabian Sea Mixed Layer Dynamics Experiment, Mooring Deployment Cruise Report, R/V *Thomas Thompson* Cruise Number 40, 11 October-25 October 1994. Upper Ocean Processes Group, UOP Technical Report 95-1, Woods Hole Oceanographic Institution Technical Report WHOI-95-01, 64 pages
- Heinmiller, Robert H., 1976. Mooring Operations Techniques of the Buoy Project at the Woods Hole Oceanographic Institution. Woods Hole Oceanographic Institution Technical Report, WHOI-76-69, 94 pp.
- Trask, Richard P., and Robert A. Weller, 1995. Cyclic Fatigue Testing of Surface Mooring Hardware for the Arabian Sea Mixed Layer Dynamics Experiment. Upper Ocean Processes Group, UOP Technical Report 95-15, Woods Hole Oceanographic Institution Technical Report, WHOI-95-16, 66 pp.

Appendix 1: Cruise Participants

WHOI

Robert Weller, Chief Scientist
Paul Bouchard
Jim Dunn
Melanie Fewings
Albert Fischer
Sandy Lucas
Will Ostrom
Jim Ryder

Chilean Navy Hydrographic and Oceanographic Service (SHOA)

Claudia Valenzuela
Manuel Castillo

University of Concepcion

Rodrigo Castro
Luis Cuevas
Marcelo Gutierrez
Carlos Moffat
Marcel Ramos
Efrain Rodriguez
Wolfgang Schneider

Universidad Catolica de Valparaiso

Cesar Hormazabal

SIO

Ron Comer, resident technician
John Chatwood, computer technician

APPENDIX 2: XBT TEMPERATURE PROFILES

Table 11: Outbound XBT station locations, filenames, and comments.

Note that the locations are approximate based on handwritten logs, but time UTC and date are correct. The exact GPS location of launch is stored in the header of each datafile, but the time and date stored there are incorrect, since they were incorrectly set on the XBT launch computer. Also, note that the mixed layer depth logged in stations 194-210 and 218-224 is the seasonal thermocline depth. Data quality comments are extracted from the handwritten log, and from a first rough look at the data.

XBT type	Lat (°S)	Lon (°W)	Oct-00 day	Time (UTC)	Filename	mixed layer	Data quality comments
T7	18 32.9100	070 34.7200	3	0005	T7_00194	35	
T7	18 36.0000	070 40.0000	3	0049	T7_00195		Bad cast
T7	18 43.7000	070 47.5000	3	0133	T7_00196	40	
T7	18 46.8700	070 51.8000	3	0200	T7_00197	40	
T7	18 49.4650	070 56.9980	3	0233	T7_00198	50	
T7	18 52.3000	071 02.1000	3	0300	T7_00199	50	
T7	18 55.2700	071 09.6400	3	0330	T7_00200	55	
T7	18 58.6313	071 16.3895	3	0409	T7_00201	60	
T7	19 01.1510	071 20.8711	3	0433	T7_00202	60	
T7	19 04.6300	071 26.5800	3	0503	T7_00203	85	
T7	19 07.7100	071 31.6900	3	0533	T7_00204	75	
T7	19 10.5900	071 36.5300	3	0600	T7_00205	70	
T7	19 15.1900	071 44.4900	3	0644	T7_00207	65	
T7	19 18.4100	071 49.9500	3	0714	T7_00208	85	
T7	19 21.2800	071 54.7700	3	0731	T7_00209	75	
T7	19 25.7000	072 02.0680	3	0805	T7_00210	60	XBT lat/lon logged after cast, 0822
T7	19 27.1084	072 04.3700	3	0833	T7_00211	60	
T7	19 30.3400	072 09.8200	3	0904	T7_00212	50	
T7	19 33.2900	072 14.8500	3	0931	T7_00213	60	
T7	19 36.9579	072 21.1830	3	1006	T7_00214	50	
T7	19 39.9690	072 26.1860	3	1034	T7_00215	60	
T7	19 42.8000	072 31.0600	3	1101	T7_00216	60	
T7	19 46.0000	072 36.3900	3	1131	T7_00217	25	
T7	19 52.3280	072 46.8390	3	1230	T7_00218	95	
T7	19 55.4100	072 52.1800	3	1300	T7_00219	95	
T7	19 58.6400	072 57.5900	3	1330	T7_00220	90	
			3	1401			On station CTD 1, thermosalinograph turned on 1725Z
T7	20 01.4558	073 04.4740	3	1818	T7_00221	60	
T7	20 00.8000	073 14.0200	3	1859	T7_00222	60	
FD	20 00.6104	073 16.8337	3	1918	TF_00223	60	
T7	20 00.2500	073 24.7000	3	1954	T7_00224	40	
T7	20 00.1408	073 30.5193	3	2021	T7_00225	40	
T7	20 00.0376	073 36.8260	3	2051	T7_00226	50	
T7	19 51.9104	073 43.8181	3	2123	T7_00227	60	During XBT save, a possible error occurred; data looks OK (skipped file 228)
T7	19 59.9600	073 50.6200	3	2155	T7_00229		XBT wire broken; data bad below 200 m
T7	20 00.0200	073 56.6300	3	2222	T7_00230	60	
T7	20 00.0200	074 02.7600	3	2250	T7_00231	60	
T7	20 00.0136	074 10.3659	3	2322	T7_00232	70	
T7	19 59.9610	074 16.5807	3	2352	T7_00233	80	
T7	19 59.9500	074 22.9400	4	0021	T7_00234	100	
T7	20 00.1000	074 31.2400	4	0102	T7_00235	95	
T7	20 00.1513	074 38.1490	4	0133	T7_00236	90	
T7	20 00.0059	074 45.4639	4	0204	T7_00237	80	
T7	19 59.9500	074 50.6390	4	0234			XBT bad (no file, no number skipped)
T7	19 59.9800	074 56.9900	4	0300	T7_00238	75	

T7	20	00.0150	075	04.0330	4	0330	T7_00239	100	
T7	19	59.8874	075	11.0062	4	0401	T7_00240	60	
T7	19	59.9640	075	17.1601	4	0431	T7_00241	65	
T7	20	00.0683	075	23.3670	4	0459	T7_00242	60	
T7	20	00.0887	075	29.9630	4	0532	T7_00243	60	
T7	20	00.0852	075	36.4086	4	0559	T7_00244	300	Bob says bad cast; ML >300
T7	19	59.9735	075	42.0025	4	0630	T7_00245	55	
T7	19	51.9106	075	49.5162	4	0701	T7_00246	55-60	
T7	19	59.9465	075	56.0545	4	0731	T7_00247	50	
T7	19	59.9400	076	02.8100	4	0800	T7_00248	40	
T7	20	00.0851	076	09.6656	4	0831	T7_00249	60	
T7	19	59.9800	076	17.2220	4	0906	T7_00250	70	
T7	19	59.9262	076	22.6202	4	0931	T7_00251	60	
T7	19	59.9300	076	29.4200	4	1002	T7_00252	50	
T7	20	00.0640	076	35.8950	4	1030	T7_00253	60	
T7	19	59.9900	076	42.4100	4	1100	T7_00254	70	
T7	19	59.9300	076	48.6800	4	1130	T7_00255	60	
T7	19	59.9900	076	57.0300	4	1208	T7_00256	80	
T7	19	59.9800	077	02.0900	4	1232	T7_00257	90	
T7	19	59.9500	077	05.5100	4	1247	T7_00258	85	
					4	1330			XBT machine down to fix SeaBeam plotter
T7	19	59.9100	077	21.8800	4	1404	T7_00259	95	XBT computer time Set to local (-4)
T7	20	00.0000	077	28.8400	4	1435	T7_00260	100	
T7	20	00.4000	077	35.2400	4	1504	T7_00261	100	
T7	20	00.1000	077	41.6600	4	1534	T7_00262	100	
T7	19	59.9471	077	47.3640	4	1601	T7_00263	100	
T7	20	00.0000	077	55.5800	4	1634	T7_00264	100	
T7	20	00.1000	078	02.0200	4	1706	T7_00265	100	
T7	20	00.2000	078	08.7900	4	1734	T7_00266	100	
T7	19	59.9500	078	15.6000	4	1802	T7_00267	100	logged good, but looks bad below 200m
T7	19	59.9300	078	22.1800	4	1834	T7_00268	100	
T7	19	59.9400	078	28.5800	4	1910	T7_00269	120	
FD	19	59.9400	078	35.5700	4	1935	TF_00270	90	
T7	19	59.9500	078	39.7810	4	2000	T7_00271	110	
T7	19	59.9600	078	46.1700	4	2029	T7_00272	110	
T7	19	59.9500	078	53.2800	4	2101	T7_00273	110	
T7	19	59.9800	078	59.8900	4	2131	T7_00274	110	
T7	19	59.9800	079	06.7100	4	2203	T7_00275	110	
T7	20	00.0150	079	13.2830	4	2232	T7_00276	120	
T7	20	00.0340	079	19.1624	4	2300	T7_00277	120	
T7	20	00.0100	079	26.1120	4	2332	T7_00278	140	
T7	19	59.9900	079	35.2400	5	0013	T7_00279	140	
T7	20	00.0500	079	39.2800	5	0031	T7_00280	140	
T7	20	00.0200	079	44.7900	5	0100	T7_00281	140	
T7	19	59.9400	079	52.5200	5	0131	T7_00282	120	
T7	20	00.0500	079	59.5900	5	0204	T7_00283	100	
T7	20	00.0200	080	05.7300	5	0231	T7_00284	115	
T7	20	00.0030	080	12.9000	5	0303	T7_00285	110	
T7	20	00.0370	080	18.4400	5	0328	T7_00286	110	Logged good, but all XBT data looks bad
T10	20	00.0314	080	26.7423	5	0406	T0_00287	115	Used T-10 since no T-7 could be found
T7	19	59.9600	080	33.5300	5	0433	T7_00288	100	
T7	19	59.9100	080	39.6000	5	0504	T7_00289	130	
T7	19	59.9900	080	45.9400	5	0533	T7_00290	135	
T7	20	00.1400	080	53.0900	5	0606	T7_00291	110	
T7	20	00.1000	080	59.3600	5	0634	T7_00292	130	
T7	20	00.0454	081	06.2684	5	0706	T7_00293	95	First probe did not load properly; had to get another
T7	20	00.0701	081	12.2506	5	0734	T7_00294	80	
T7	20	00.1152	081	18.7332	5	0804	T7_00295	125	
T7	20	00.3092	081	24.9388	5	0832	T7_00296	100	
T7	20	00.0420	081	32.2870	5	0904	T7_00297	100	
T7	19	59.9530	081	38.9450	5	0934	T7_00298	80	
T7	20	00.0104	081	45.2834	5	1002	T7_00299	110	
T7	20	00.1126	081	52.0711	5	1032	T7_00301	120	error in file T7_00300; quit program and restarted

T7	20	00.0370	081	59.2380	5	1105	T7_00302	130	
T7	19	59.9898	082	05.1036	5	1132	T7_00303	140	
T7	19	59.9008	082	11.8615	5	1202	T7_00304	110	
T7	20	00.1040	082	18.4570	5	1231	T7_00305	130	
T7	20	00.0200	082	24.7500	5	1300	T7_00306	140	
T7	19	59.9200	082	31.9400	5	1332	T7_00307	150	
T7	19	59.9700	082	38.0700	5	1400	T7_00308	125	
T7	20	00.0000	082	46.2500	5	1437	T7_00309	140	
T7	20	00.0500	082	52.6800	5	1503			XBT: Bad (no file)
T7	20	00.0500	082	59.1000	5	1532	T7_00311	150	Marked bad in log; data looks OK
T7	19	59.9700	083	04.8000	5	1601	T7_00312	150	
T7	19	59.9600	083	11.3400	5	1630	T7_00313	160	
T7	19	59.9697	083	18.0225	5	1701	T7_00314	145	
T7	19	59.9900	083	25.4200	5	1734	T7_00315	150	
T7	20	00.0400	083	33.8200	5	1811	T7_00316	150	
T7	30	00.0090	083	39.9700	5	1838	T7_00317	160	
T7	20	00.0190	083	45.2250	5	1903	T7_00318	165	
T7	20	00.0366	083	52.5041	5	1935	T7_00319	170	
T7	20	00.0316	083	59.2925	5	2007	T7_00320	170	
T7	20	00.0431	084	05.3610	5	2035	T7_00321	170	
FD	20	00.0614	084	11.0876	5	2101	TF_00322	160	
T7	20	00.0000	084	17.4700	5	2130	T7_00323	160	
T7	20	00.1100	084	23.8500	5	2159	T7_00324	140	
T7	20	00.0600	084	31.1100	5	2233	T7_00325	130	
T7	19	59.9947	084	37.1532	5	2301	T7_00326	140	
T7	19	59.9186	084	43.7678	5	2332	T7_00327		
T7	19	59.9500	084	49.9990	6	0001	T7_00328	170	
T7	20	00.0425	084	57.0079	6	0033	T7_00329	150	
					6	0106			Start bottom survey, stop outbound XBTs

Table 12: Locations of CTD casts

Station N°	Date	Start Time [UTC]	Start Latitude [dd°mm.mm']	Start Longitude [ddd°mm.mm']	Depth [m]
1	00-10-06	20:20	20° 13.64'S	085° 3.07'W	4459
2	00-10-09	01:22	19° 59.99'S	084° 0.07'W	4365
3	00-10-09	10:22	19° 59.95'S	083° 0.06'W	4379
4	00-10-09	20:19	19° 59.97'S	082° 0.44'W	4006
5	00-10-10	05:12	19° 59.99'S	081° 0.05'W	3300
6	00-10-10	14:44	20° 0.08'S	080° 0.23'W	3793
7	00-10-11	03:05	20° 0.01'S	078° 30.02'W	4190
8	00-10-11	14:04	20° 0.04'S	077° 0.08'W	4607
9	00-10-12	02:00	20° 0.20'S	075° 30.05'W	4980
10	00-10-12	13:16	20° 0.25'S	074° 0.06'W	4742
11	00-10-13	01:18	20° 0.33'S	072° 23.17'W	4043
12	00-10-13	10:31	20° 0.02'S	071° 19.31'W	5500
13	00-10-13	16:35	20° 0.0'S	071° 0.00'W	3006

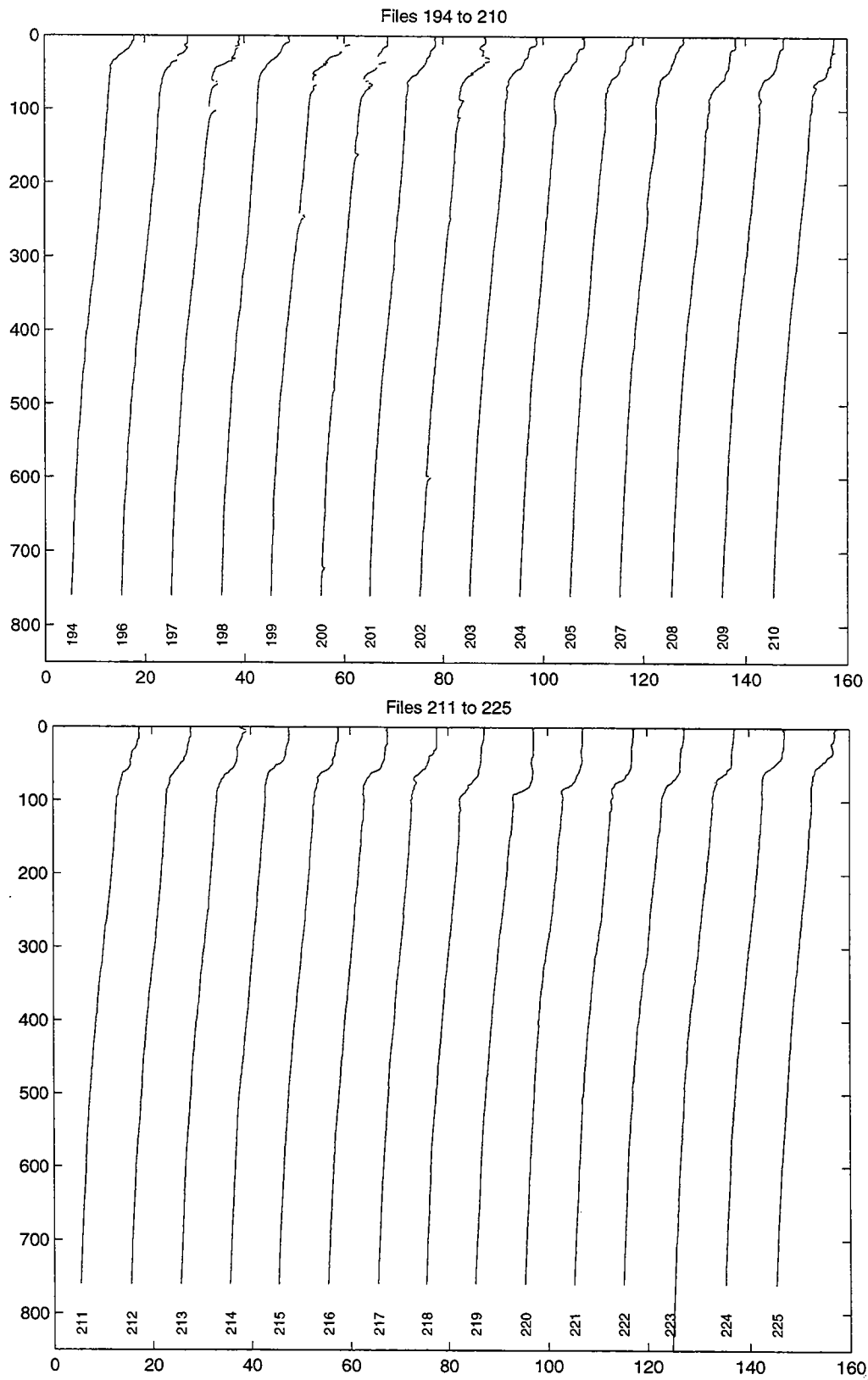

Figure 28: Profile plots of the XBT station data by station number, separated by 10°C.

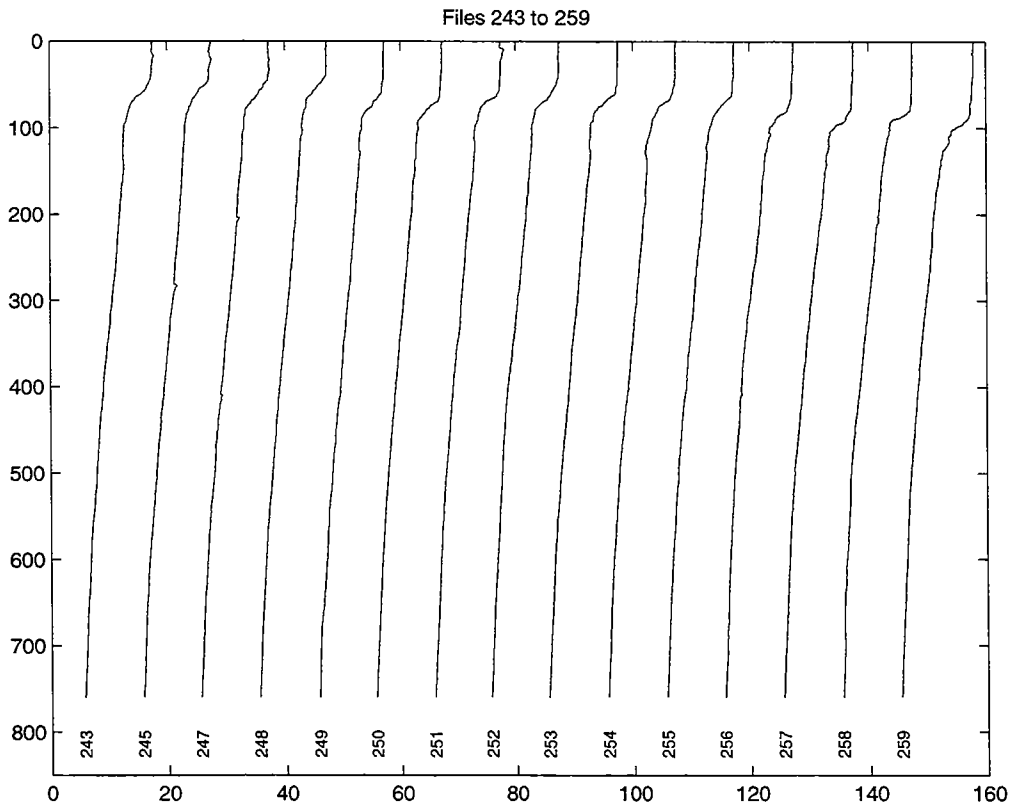
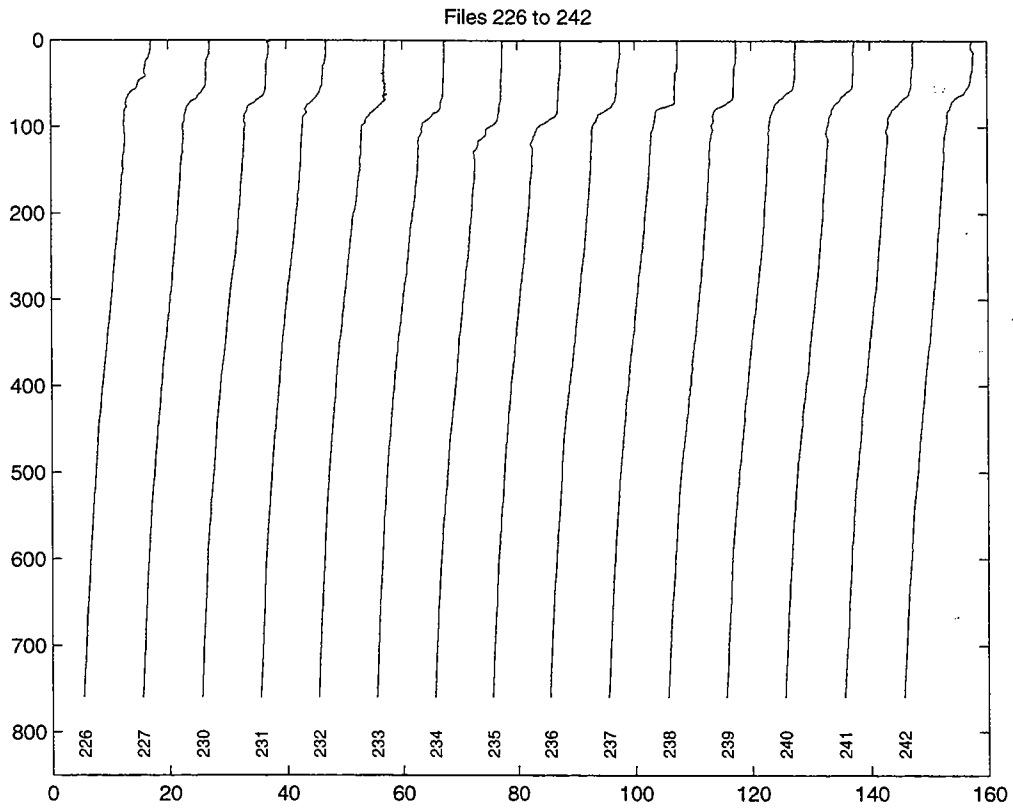

Figure 29: Profile plots of the XBT station data, separated by 10°C.

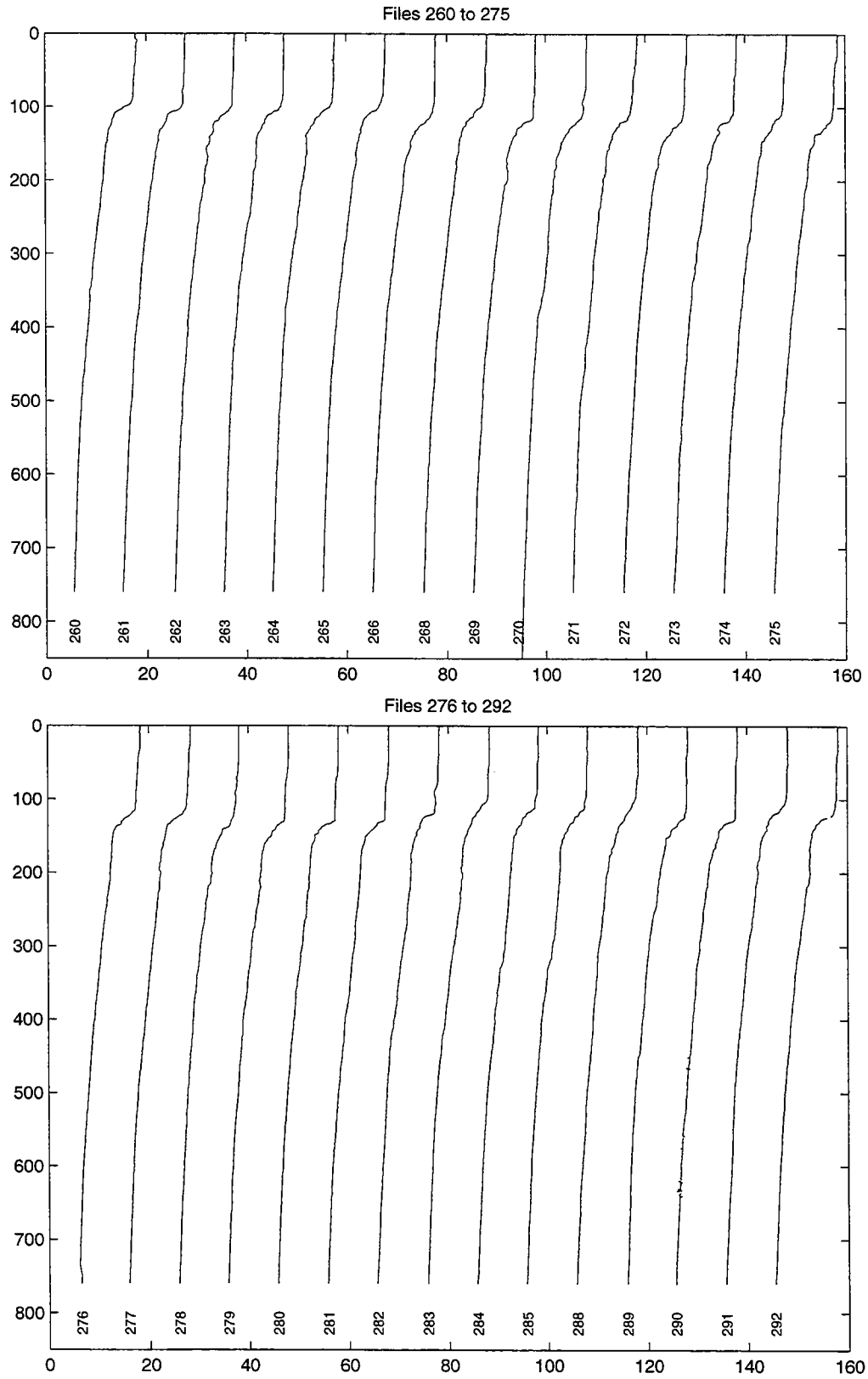

Figure 30: Profile plots of the XBT station data, separated by 10°C.

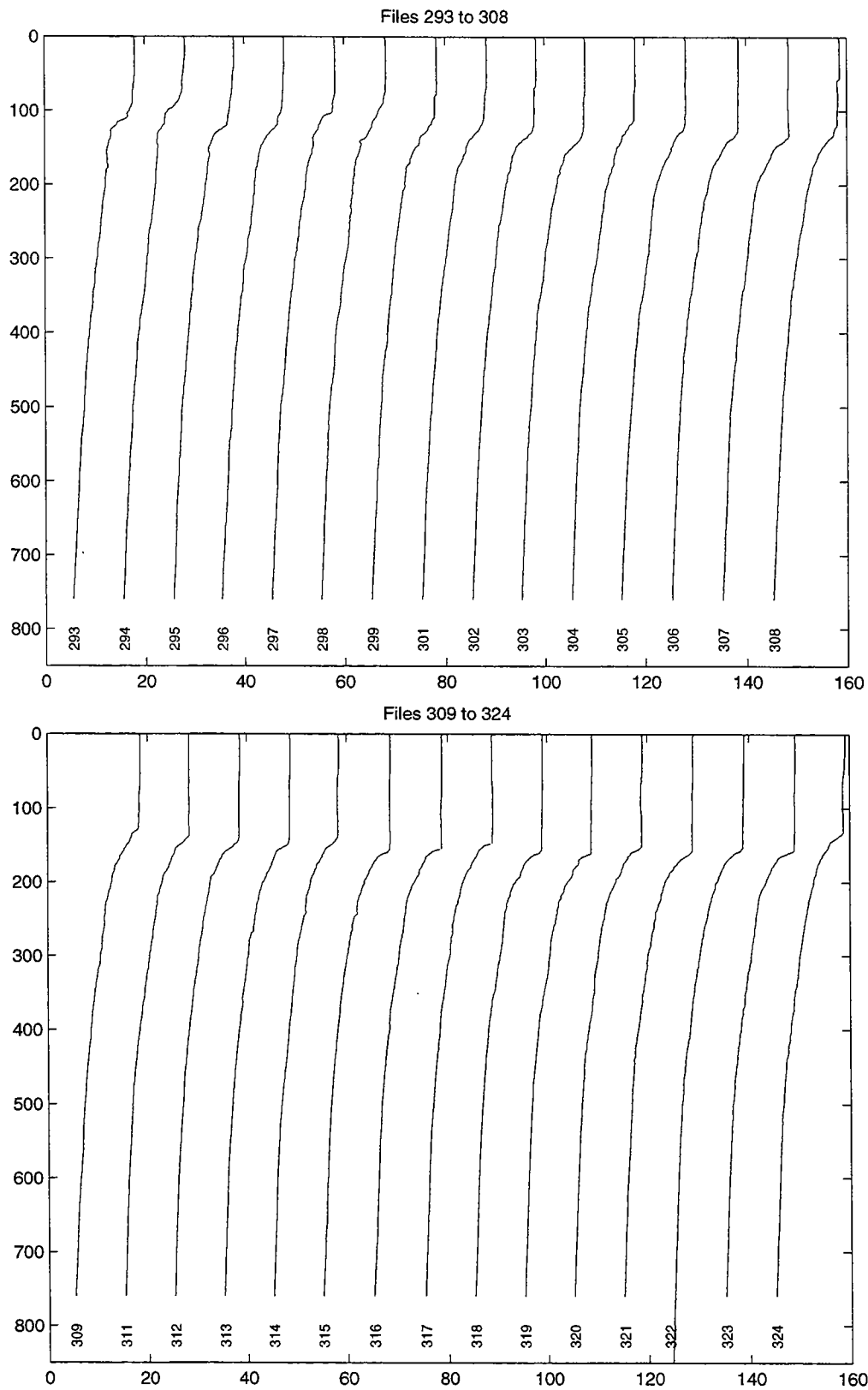

Figure 31: Profile plots of the XBT station data, separated by 10°C.

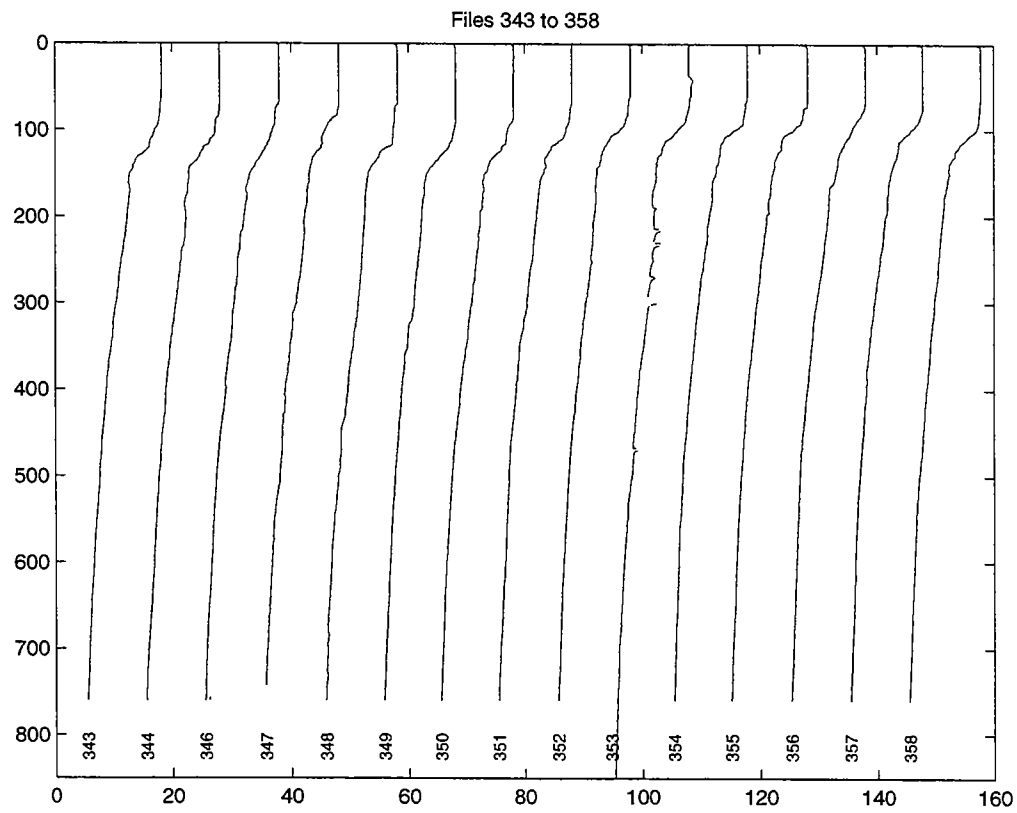
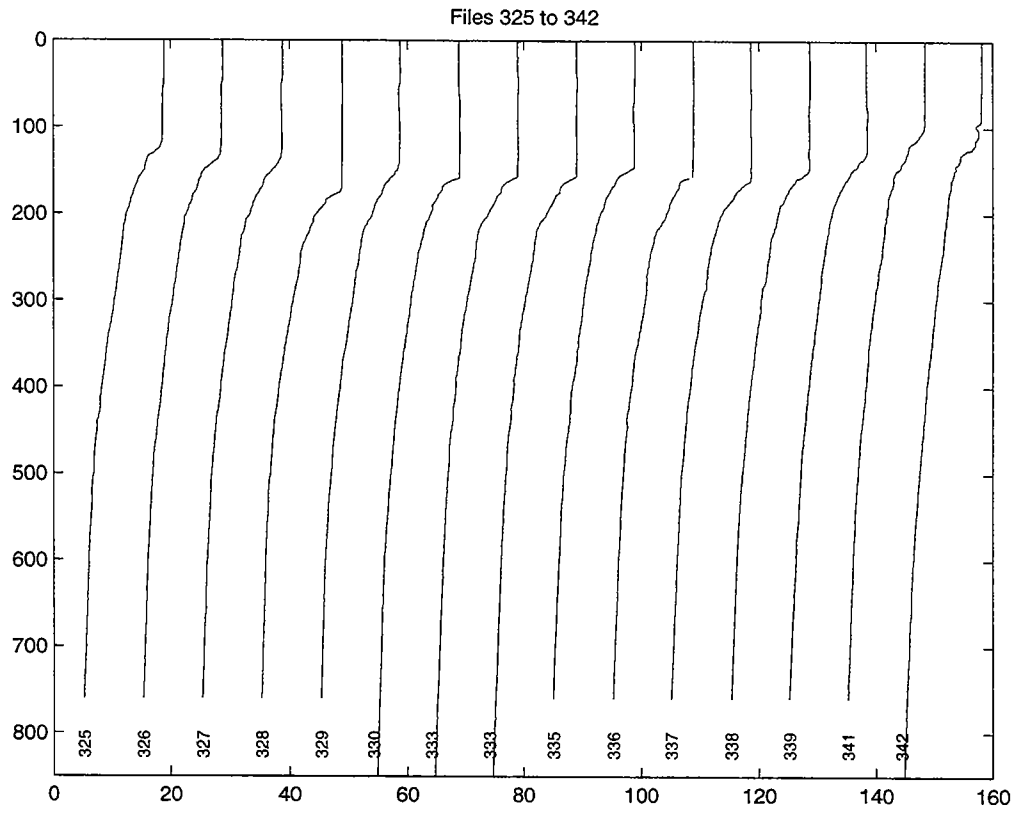

Figure 32: Profile plots of the XBT station data, separated by 10°C.

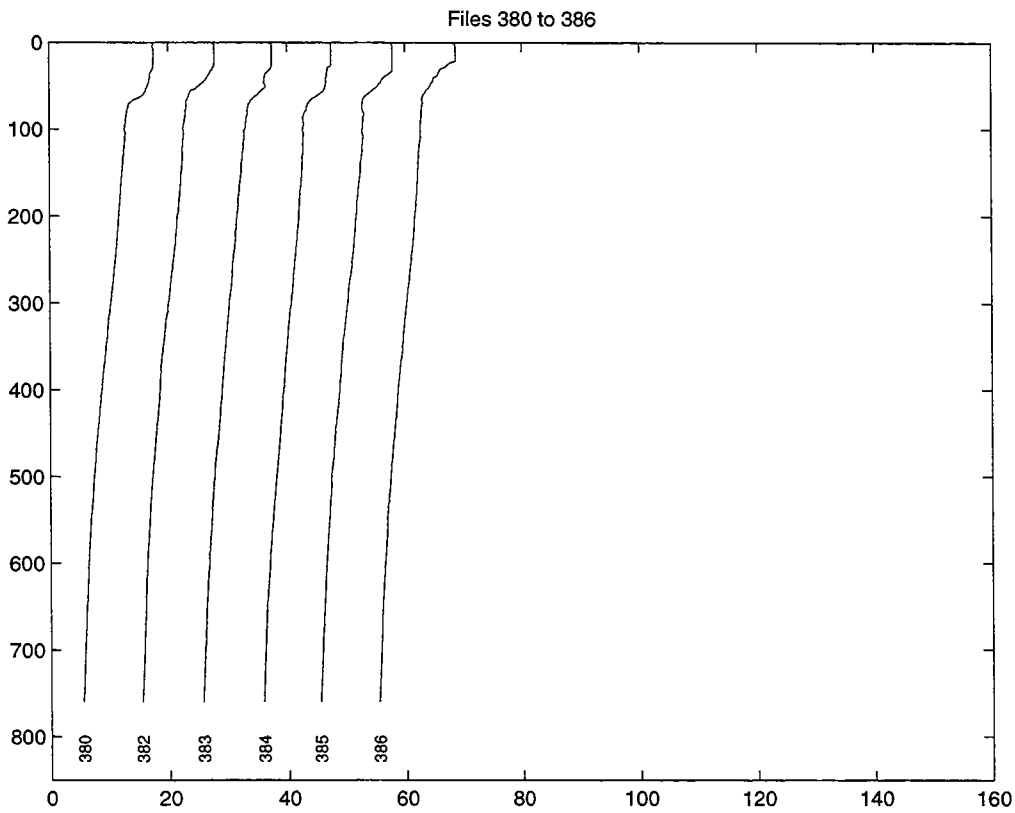
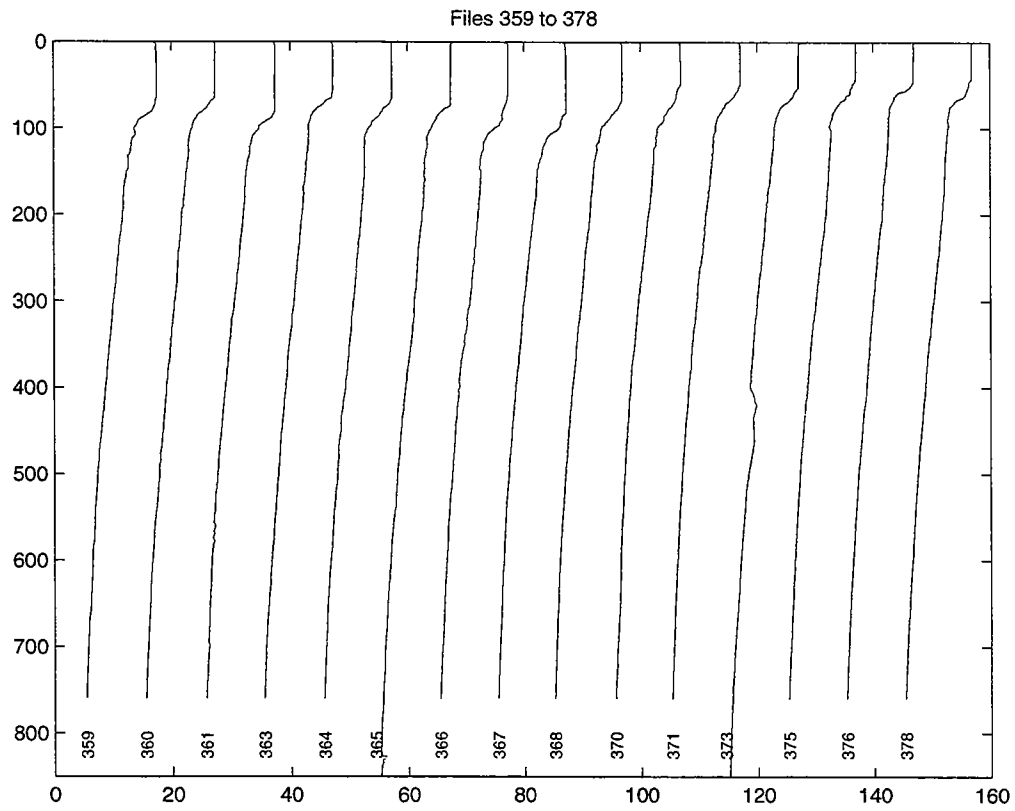

Figure 33: Profile plots of the XBT station data, separated by 10°C.

APPENDIX 3: WHOI Instrumentation Deployed During STRATUS 1

A. INSTRUMENT INFORMATION (Serial numbers, deploy time, sampling rates)

Table 13: Instrumentation Mounted On 3 Meter Discus Buoy Tower And Bridle

Parameter	Sensor ID	Sampling Rate/Record Rate	Time Deployed	Time Spike (UTC) Start - Finish	Elevation relative to water line (meters)
IMET system 1	Logger 117	1 Min.			
Wind speed	WND 104				3.39
Wind direction	WND 104				3.39
Air Temperature	TMP 102				2.04
Relative Humidity	HRH 108				2.74
Barometric Pressure	BPR 107				2.79
Precipitation	PRC 102				3.14
Long-wave Radiation	LWR 101				3.48
Short-wave Radiation	SWR 111			15:00:15 - 15:02:02 4 October 2000	3.47
Sea Temperature	SST 003				-0.57
IMET system 2	Logger 226				
Wind speed	WND 105				3.32
Wind direction	WND 105				3.32
Air Temperature	TMP 104				2.02
Relative Humidity	HRH 110				2.77
Barometric Pressure	BPR 106				2.83
Precipitation	PRC 101				3.17
Long-wave Radiation	LWR 106				3.58
Short-wave Radiation	SWR 109			15:00:15 - 15:02:02 4 October 2000	3.57
Sea Temperature	SST 104				-0.57
Stand-alone Relative Humidity	HRH 204				2.75
Tidbit Air Temp	358910	30 Min.		19:23-20:14 29 Sept. 2000	2.20
SBE-39 Floating SST	0072	5 Min.		22:01 - 22:11 28 Sept. 2000	-0.02
Tidbit Sea Temp	358909	30 Min.		19:23 - 20:14 29 Sept. 2000	-0.57
SeaCat Conductivity/ Temperature	1878	3.75 Min.		20:29 - 20:38 28 Sept 2000	-0.57

Table 14: Instrumentation mounted on the mooring line of the 3 meter discus buoy

Instrument	Serial Number	Depth from Mooring Diagram (meters)	Sampling Rate/Record Rate	Time Deployed (Record Start)	Time Spike (UTC) Start - Finish	Depth relative to water line (meters)	Parameter(s) Measured
SeaCat	1875	3.71	3.75 Min.		20:29 - 20:38 28 Sept. 2000		Temperature
	1873	7					Conductivity
	2325	16					
	1880	30					
Brancker T-Pod	3763	13	30 Min.		19:59 - 21:01 28 Sept 2000		Temperature
	4491	35					
	3301	47.5					
	3831	55					
	3830	70					
	3764	77.5					
	3258	92.5					
	3263	100					
	4495	115					
	4485	145					
	4228	160					
	3836	220					
	3259	250					
VMCM	VM038	10	7.5 Min.	13:30:45	ⓐ 17:33:00 ⓑ 20:03:00		East and North Currents
	VM037	20		13:19:01	ⓐ 17:35:00 ⓑ 20:04:00		
New Gen VMCM	VM01	350		14:54:10	ⓐ 17:32:00 ⓑ 20:05:00		
				7 Oct 2000 (Bands Off)	3 Oct 2000 (Rotor Spin)		
MicroCat	1328	40	3.75 Min.		20:15 - 20:28 28 Sept 2000		Temperature
	1326	62.5					Conductivity
	1305	85					
	1330	130					
	1306	190					
SBE-39	0050	25 (on Chlam)	5 Min.		22:01 - 22:11 28 Sept 2000		Temperature
	0048	349					
	0049	350					
Chlam	ACH0126	25	2 Hours				
ADCP	TSN-1218	135	30 Min				East and North Currents
FSI	1325A	235	30 Min				East and North Currents
Tidbit	358909	(on bridle)	30 Mins		19:23-20:14 29 Sept. 2000	1 (on bridle)	
	358907	10 (on VMCM)					
	358908	16 (on SeaCat)					
Acoustic Rain Guage	F9	23.5					Precipitation

B.MOORING LOG

Moored Station Log

PAGE 1

(fill out log with black ball point pen only)

ARRAY NAME AND NO. Stratus 1 MOORED STATION NO. 1052

Launch (anchor over)

Date 7 Oct. 2000 Time 20:43:00 UTC
Latitude 20° 09.508' N or (S) Longitude 085° 08.878' E or (W)
Position Source: GPS, LORAN, SAT. NAV., OTHER GPS
Deployed by: Ostrom, Bouchard, Dunn, Ryder Recorder/Observer: Sandy Lucas
Ship and Cruise No Melville, Cook 02 Intended duration: 365 days
Depth Recorder Reading 4440 m Correction Source: Sea Beam
Depth Correction 0 m
Corrected Water Depth 4440 m Magnetic Variation: 8.3 (E) or (W)
Anchor Position: Lat. 20° 9.4174' N or (S) Long. 85° 9.0729' E or (W)
Argos Platform ID No. See Nex Page Additional Argos Info may be found on pages 2 and 3.

Acoustic Release Information

Release No. 339 Enable 42 Disable 41
Receiver No. 4 Tested to 1,000 meters
Interrogate Freq. 11 kHz Release Command 43
Reply Freq. 10 kHz

Recovery (release fired)

Date _____ Time _____ UTC
Latitude _____ N or S Longitude _____ E or W
Position Source: GPS, LORAN, SAT. NAV., OTHER _____
Recovered by: _____ Recorder/Observer: _____
Ship and Cruise No. _____ Actual duration: _____ days
Distance from actual waterline to buoy deck _____ meters

Surface Components

Buoy Type 3m. Discus Hull Color(s) Hull Blue Bulb Tower White
with every stripe

Buoy Markings _____

Surface Instrumentation			
Item	ID	Height *	Comments
Data Logger	117	-	Located in well / System #1
Relative Humidity	HEH 108	231 cm	(tip of sensor) Relative to Buoy Deck
Wind Module	WWD 104	296 cm	(Prop. Axis)
Air Temp.	TMP 102	161 cm	(end of Probe)
Barom. Pressure	BPR 107	236 cm	(Center of Port)
Short Wave Rad.	SWR 111	314 cm	(Base of Dome)
Long Wave Rad.	LWR 101	315 cm	(" " ")
Precipitation	PRC 102	271 cm	(Top of funnel)
Argos Trans.	PTT 27916		PTT 101
	27917		
	27918		
Data Logger	226		located in well / System #2
Relative Humidity	HEH 110	234 cm	(tip of sensor)
Wind Module	WWD 105	289 cm	(Prop. Axis)
Air Temp	TMP 104	159 cm	(end of Probe)
Barom. Pressure	BPR 106	240 cm	(Center of Port)
Short Wave Rad.	SWR 109	314 cm	(Base of Dome)
Long Wave Rad.	LWR 106	315 cm	(" " ")
Precipitation	PRC 101	274 cm	(Top of funnel)
Argos Trans.	PTT 27919		PTT 104
	27920		
	27921		
Relative Humidity	HEH 204	232 cm	(Tip of sensor) STAND ALONE
Tidbit Air Temp	358910	177 cm	Tied to TMP 104 (Sys #2 Air Temp)
Flashing Light	24412	279 cm	Solar Power (mid height)
Radar Reflector	none	211 cm	(mid height)

* Height above buoy deck

Sub-Surface Instrumentation on Buoy and Bridle			
Item	ID	Depth†	Comments
IMET/SST	SST SST003	1 m	System #1
IMET/SST	SST 104	1 m	System #2
Sea Cat	1878	1 m	
TidBit	358909	1 m	located on Bridle next to SST #1
ARGOS Transmitter	11427		Clamped to Bridle
SBE 39	0072	0 m	Floating SST
Bridle	—	—	No tension logged. Termination of Bridle to 0.48 m. 3/4" Proof Coil Chain is: U-joint → 1" Chain Shackle → 1" Endlink → 7/8" Chain Shackle
† Depth below buoy deck			

Sub-Surface Components

	Type	Size(s)	Manufacturer		
Chain					
Wire Rope					
Synthetics					
Hardware					
Flotation	Type (G.B.s, Spheres, etc)	Size	Quantity	Color	
	G.B.s w/ Hard Hats*	17"	81	yellow	
	* Lost at least 1 after deployment (see pg 10)				
No. of Flotation Clusters 1					
Anchor Dry Weight 9300 lbs					

MOORED STATION NUMBER

1052

Item No.	Lgth [m]	Item	Inst No.	Time Over	Notes	Data No.	Calc Dpth	Time Back	Notes
3-71	1	0.48	3/4" Procs Coil Chain						
	2		Sea Cat w/ Loadbar	1875	13:27:30	Inst. hanging over side but not in H ₂ O			
	3	2.06	3/4" Procs Coil Chain						
7	4		Sea Cat w/ Loadbar	1873	13:26:50				
	5	1.3	3/4" Procs Coil Chain						
10	6		3/4" Cage VMCM	VM038	13:21:50	Bands 066 140-13:30:45			
	7	—	T. dbit on VMCM cage	358907	13:30:45				
13	8	0.82	3/4" Procs Coil Chain						
	9		TPOD w/ Loadbar	3763	13:30:22				
16	10	1.78	3/4" Procs Coil Chain						
	11		Sea Cat w/ Load bar	2325	13:38:17				
20	12	—	T. dbit on Sensor loadbar	358908	13:38:17				
	13	2.26	3/4" Procs Coil Chain						
23.5	14		3/4" VMCM Cage	VM037	13:19:01	Bands 066			
	15	0.96	3/4" Procs Coil Chain						
25	16		Rain Gauge Trans. up	F9	13:21:55				
	17	0.48	3/4" Procs Coil Chain						
25	18		CHLAM	ACT0126	13:21:40				
	19	—	SBE-39 located on CHLAM	0050	13:21:40				
25	20	2.74	3/4" Procs Coil Chain						

Date/Time	Comments
line 7	Ⓣ T. dbit co located with the VMCM Temp. Sensor (see photo)
line 12	Ⓣ T. dbit located on Sea Cat Load bar near temp sensor
line 19	Ⓣ SBE-39 located on CHLAM (see photo)
line 1 to Bridle	Ⓣ atted to Bridle w/ a U-joint → 1" Chain Shack. → 7/8" end link → 7/8" Chain
all lines 1-75 to each other	Ⓣ 3/4" Chain Shackles, 7/8" end link, 3/4" Chain Shackles

MOORED STATION NUMBER

1052

Depth from Previous

Item No.	Lgth [m]	Item	Inst No.	Time Over	Notes	Data No.	Calc Dpth	Time Back	Notes
30		SeaCast w/ Lead bar	1880	13:21					
	3.7	3/4" Proof Coil Chain							
35		TPOD w/ Lead bar	4491	13:18					
	3.77	3/4" Proof Coil Chain							
40		Micro Cast w/ Lead bar	1328	13:18					
	6.2	7/16" wire							
47.5		TPOD w/ Lead bar	3301	13:59:30					
	6.2	7/16" wire							
55		TPOD w/ Lead Bar	3831	14:02:40					
	6.2	7/16" wire							
62.5		Micro Cast w/ Lead bar	1326	14:04:25					
	6.2	7/16" wire							
70		TPOD w/ Lead bar	3830	14:07:50					
	6.2	7/16" wire							
77.5		TPOD w/ Lead bar	3764	14:09:30					
	6.2	7/16" wire							
85		Micro cast w/ Lead bar	1305	14:11:50					
	6.2	7/16" wire							
92.5		TPOD w/ Lead bar	3258	14:12:35					
	6.2	7/16" wire							
Date/Time		Change from original design ^{62.5} Comments							
Line 31		Switched ³²⁵⁸ microcat w/ SeaCast due to lack of Anti foul Plugs for micro cat.							

MOORED STATION NUMBER

1052

Item No.	Lgth [m]	Item	Inst No.	Time Over	Notes	Data No.	Calc Dpth	Time Back	Notes
100		T-Pod w/ Leadbar	3263	14:17:55					
	3.43	3/4" Proob Coil chain							
	0.61	3/4" Proob Coil chain			9 Links				
	9.4	7/16" wire							
115		TPOD w/ Leadbar	4495	14:21:10	End Comp Says SW: 4492				
	14.0	7/16" wire							
130		Micro cat w/ leadbar	1330	14:24:55					
	3.43	3/4" Proob Coil chain							
135		ADCP upward looking		14:29:20					
	8.5	7/16" wire							
145		TPOD w/ Leadbar	4485	14:30:28					
	14.0	7/16" wire							
160		TPOD w/ Leadbar	4228	14:34:45					
	28.5	7/16" wire							
190		Microcat w/ leadbar	1306	14:38:45					
	28.5	7/16" wire							
220		TPOD w/ leadbar	3836	14:46:02					
	13.0	7/16" wire							
235		PSI-3D ACM Sensors Down	1325A	14:44:25					
	14.0	7/16" wire							
Date/Time		Comments							
		Change from orig. Drawing: Switched 16m Microcat w/ 130m Seacat due to lack of 16m plug.							

MOORED STATION NUMBER

1052

depth from mooring	Item No.	Lgth [m]	Item	Inst No.	Time Over	Notes	Data No.	Calc Dpth	Time Back	Notes
250	61		TPOD w/ Leadbar	3259	14:46:10					
	62	100.0	3/8" wire							
349	63	—	SBE-39 (+) Clamped to wire	0048	14:49:25	#20 14:54:10				
350	64		New from VM 3/4" Cage	VM01	14:49:25	Bands 066 #20 14:54:10				
	65	100.0	3/8" wire							
450	66	—	SBE-39 Clamped Just above wire End	0049	15:10:45					
	67	300.0	3/8" wire							
	68	500.0	3/8" wire							
	69	500.0	3/8" Wire							
	70	200.0	3/8" Wire		15:56:20					
	71	100.0	3/8" wire		16:10:00	Wire Repair See note				
	72	200.0	7/8" Nylon			Special termination between				
	73	500.0	7/8" Nylon							
	74	150.0	7/8" Nylon		16:38	Adjusted from 300m due to #20 depth				
	75	500.0	7/8" Nylon							
	76	500.0	7/8" Nylon							
	77	100.0	1" Nylon							
	78	1400.0	1 1/8" PolyPro							
	79	(81)	17" Glass Balls		19:48					
	80	5	1/2" Truss Chain							

Date/Time	Comments
line 63	SBE-39 is clamped to wire just above termination.
line 66	SBE-39 is Clamped to wire just above termination. ^{lower} Bolt stripped Sealed w/ Blk tape (See Photo)
lines 71 & 72	wire + Nylon are on piece w/ a wrapped termination
line 74	Reduced to 150 m from 300 m due to anchor depth of 4450m
line 71	wire Rubbed on deck Edge (approx 12m above wire/Nylon Jct.) Repair was made w/ Silicon and Black Tape

MOORED STATION NUMBER

1052

Item No.	Lgth [m]	Item	Inst No.	Time Over	Notes	Data No.	Calc Dpth	Time Back	Notes
81		Bass Acoustic Release w/ leader	25290						
82	5.0	1/2" Trawl Chain							
83		Acoustic Release E. 677 Model 522	339	20:24:20	Puller Spring Disabled at 22:38				
84	5.0	1/2" Trawl Chain							
85	20.0	1" Samson Nylon							
86	5.0	1/2" Trawl Chain							
87		Anchor (8000 lbs in #20)	20-43:00	20:43:00	20° 09.508 S 85° 08.878 W				
88									
89									
90									
91									
92									
93									
94									
95									
96									
97									
98									
99									
100									

Date/Time	Comments
line 81	Bass Release: Interrogate freq. 11 kHz Reply 12 kHz Release 323616
line 83	Acoustic Release Receiver # 4

C. INSTRUCTIONS FOR LOADING THE RDI WORKHORSE ADCP IN TO CAGE

The fit of the instrument into its titanium cage is very tight, and the following insertion procedure (Figure 36) works successfully.

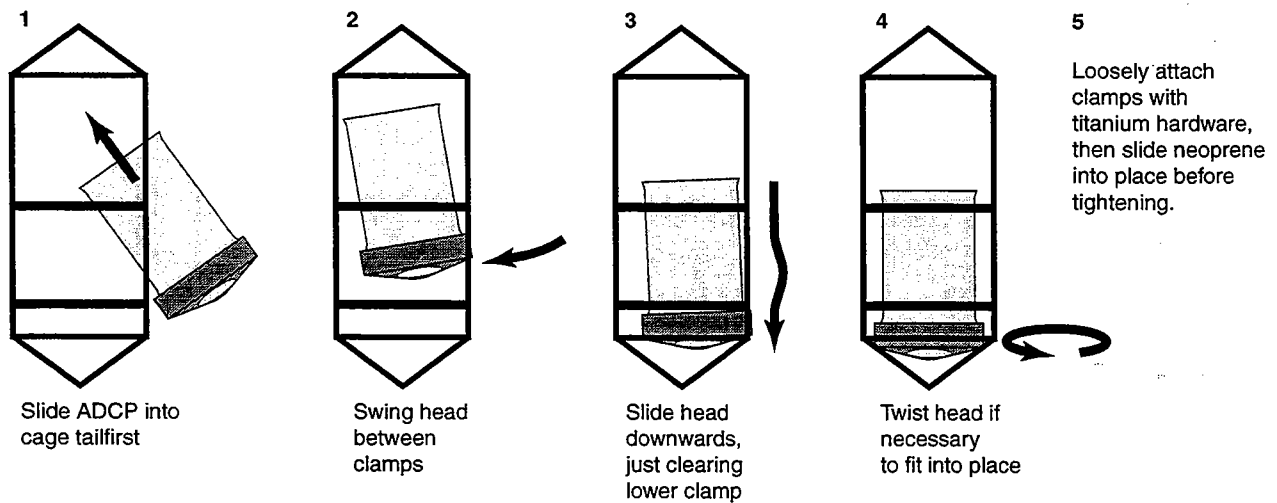

Figure 36: Diagram describing insertion of RDI ADCP into cage.

APPENDIX 5: STRATUS MOORING DEPLOYMENT PROCEDURES

The STRATUS surface mooring deployed from the R/V *Melville* was set using the UOP two phase mooring technique. Phase 1 involved the lowering of approximately 40 meter of instrumentation over the starboard side of the ship. Phase 2 was the deployment of the buoy into the sea. The benefits from lowering the first 40 meters of instrumentation are three fold in that: (1) it allows for the controlled lowering of the upper instrumentation; (2) the suspended instrumentation, attached to the buoy's bridle acts as a sea anchor to stabilize the buoy during the deployment of the buoy; and (3) the 80 meter length of paid out mooring wire and instrumentation provides adequate scope for the buoy to clear the stern without capsizing or hitting the ship. The remainder of the mooring is deployed over the stern. The following narrative is the actual step by step procedure used for the STRATUS mooring deployed from the R/V *Melville*. The ship deck layout, available personnel and mooring handling equipment need to coincide when developing a surface mooring deployment scenario.

The basic deck equipment and deck layout is illustrated in Figure 37. The mooring gear used in the deployment of the surface mooring included: the TSE winch, main crane, jib crane and the standard complement of chain grabs, stopper and slip lines.

The TSE winch drum was pre-wound with the following mooring components listed from deep to shallow:

- 300 m 7/8" nylon - adjustable
- 500 m 7/8" nylon
- 500 m 7/8" nylon
- 200 m 7/8" nylon
- canvas tarp barrier interface
- 100 m 3/8" wire
- 200 m 3/8" wire
- 500 m 3/8" wire
- 500 m 3/8" wire
- 300 m 3/8" wire
- 100 m 3/8" wire
- 100 m 3/8" wire

A canvas tarp was placed between the nylon and wire rope to prevent the wire from burying into the nylon line when under tension. These mooring components were pre-wound onto the TSE winch within 24 hours of deployment. A tension cart was used to pretension the nylon and wire during the winding process. The sea condition during the deployment caused greater than usual line tension, which caused some loosening of wire turns towards the end of the wire to nylon shot. Additionally, some loosening could have been caused by the nylon compressing. The canvas shifted during the pay out of the wire rope exposing a small area of nylon line. The wire buried slightly and jammed over itself. The wire was stopped off using a kevlar "Yale" grip lashed to the wire. The line tension was transferred to the grip and the fouled wire was un-jammed, without damage.

The personnel utilized during the first phase of the operation were: a deck supervisor, winch operator, 4 mooring wire handlers, crane-whip man, and a 01 crane operator. Figure 37 illustrates the positioning of personnel during the instrument lowering phase.

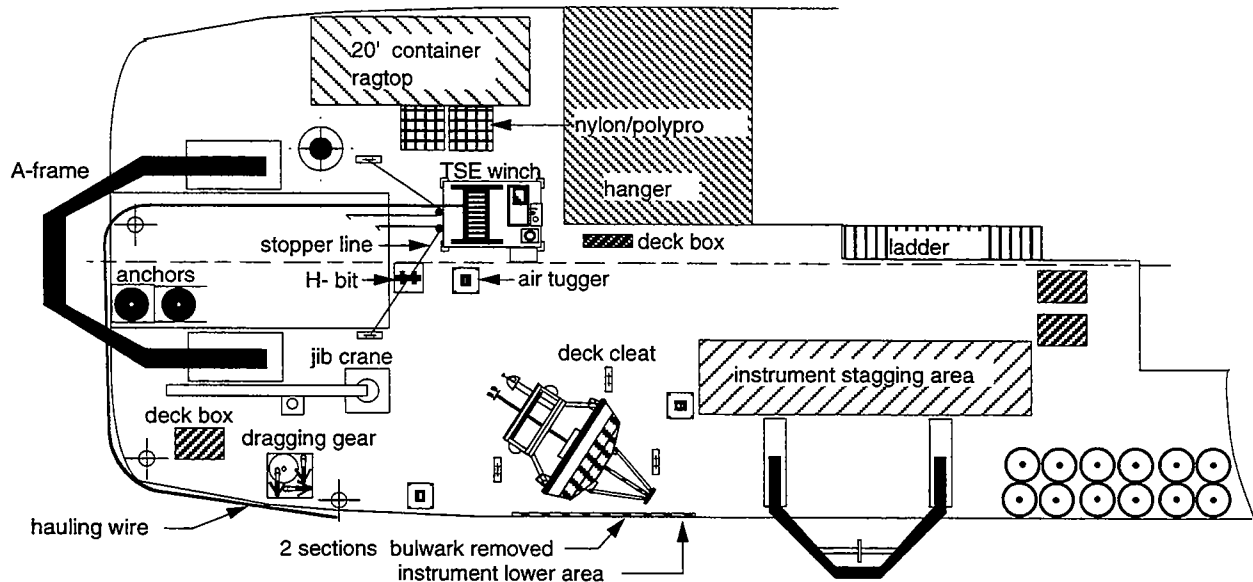

- 2700 discus buoy
- 18600 anchors
- 7000 TSE winch
- 14000 ragtop container
- 2000 dragging gear
- 3750 wire & nylon rope
- 2000 poly pro line
- 3000 mooring hardware deck boxes
- 53050 lbs. main deckload

R/V Melville - STRATUS deck plan
 W.Ostrom
 9/29/00
 version: 2
 scale: 1" = 15'
 note: ⊕ hauling wire handler position

Figure 37: Basic deck equipment and deck layout

Prior to the deployment of the mooring a 100 meter length of 3/8" diameter wire rope or hauling wire was paid out to allow its bitter end to be passed out through the center of the A-frame and around the aft starboard quarter and up forward along the starboard rail to the instrument lowering area.

The four hauling wire handlers were positioned around the aft port rail. Their positions were in front of the TSE winch, the center of the A-frame, aft starboard quarter, and approximately 5 meters forward along the starboard rail. The wire handler's job was to keep the hauling wire from fouling in the ship's propellers and pass the wire around the stern to the closest line handlers on the starboard rail.

Prior to starting the mooring deployment, the ship hove to with the ship's bow positioned so that the wind was slightly on the starboard bow. The 01 crane was extended out so that there was a minimum of 10 meters of free whip hanging over the instrument lowering area. All the sub-surface instruments had been staged in their order of deployment on the starboard side main deck. Instrumentation from 40 meters to the surface had a pre-connected shot of chain or wire shackled to the top of the instrument. Instrumentation 47.5 meters and deeper had their chain or wire shot secured to the bottom of the instrument.

The free end of the hauling wire was off spooled from the TSE winch, and passed through the A frame, out around and up to the instrument lowering area. The first instrument segment to be lowered was the 6.2 meter length of 7/16" wire rope, 40 meter depth MicroCat, 3.77 meter length of 3/4" chain, 35 meter Brancker temperature recorder and 3.7 meter shot of 3/4" chain. The instrument lowering commenced by shackling the bitter end of the hauling wire to the free end of the 6.2 meter length of 7/16" wire rope shot. The crane whip hook suspended over the instrument lowering area was lowered to approximately 1 meter from the deck. A 2 meter long green "Lift All" sling, slung in a barrel hitch, through a 3/4" chain grab was hooked onto the crane hook. The chain grab was hooked onto the 3.7 meter 3/4" chain approximately .5 meters from the free end. The sling was hooked onto the crane hook. The crane whip was raised up so that the chain and instruments were lifted off the deck approximately 0.5 meters. The crane was instructed to swing outboard one meter to clear the ship's side and slowly lowered its whip and attached mooring components down into the water. The TSE winch simultaneously paid out the hauling wire. The wire handlers positioned around the stern tending the hauling wire eased it over the starboard side and allowing only enough wire over the side to keep the deepest mooring segment vertical in the water. The 3.7 meter 3/4" chain was stopped off .5 meter above the ship's deck, using a 3/4" chain grab attached to an Ingersal Rand 1000 lb. line pull air tugger line. The crane was then directed to swing slightly inboard and lower its 3/4" chain grab to the deck. The air tugger's line hauled in enough to take over the load from the crane's chain grab. The crane hook was removed. A 3/4" diameter, nylon stopper line with a Renfro snap hook was then hooked into the loose end link shackled to the bitter end of the 3/4" chain and secured to a deck cleat. The tugger line was then eased off transferring the tension to the stopper line.

The next segment in the mooring to be lowered was the 30 meter SEACAT, and 2.74 m length of 3/4" chain. The instrument and chain were brought into the instrument lowering area with the instrument bottom end pointing outboard so that it could be shackled to the top of the stopped off chain shot. The loose end of the chain, fitted with a 3/4" chain shackle and 7/8" end link, was again hooked onto the crane whip using a slung chain grab. The crane whip was raised

taking with it the chain and instrument into a vertical position, 0.5 m off the deck. Once the crane's whip had taken the load of the mooring components and hanging over the side, the stopper line was slackened and removed. The crane swung outboard and the whip lowered. The TSE winch slowly paid out the hauling wire at a pay out rate similar to the descent rate of the crane whip.

The operation of lowering the upper mooring components in conjunction with the pay out of the hauling wire was repeated up to the 0.48 meter shot of 3/4" chain shackled to the 3.71 meter depth SEACAT. At this point the chain segment attached to the SEACAT was stopped off to the deck by inserting a 1/2" screw pin shackle and 5/8" pear ring into the middle of the 0.48 meter length of 3/4" chain. The air tugger line was hooked into the pear ring and drawn tight as the crane whip lowered the chain to the deck edge. The crane whip and chain grab were removed. The free end of 0.48 meter 3/4" chain was then shackled to the 1" end link attached to discus bridle universal joint.

The second phase of the operation was the launching of the discus buoy. There were three slip lines rigged on the discus to maintain constant swing control during the lift. One was positioned on the bridle, tower bail and a buoy deck bail (Figure 38). The 30 ft. bridle slip line was used to stabilize the bridle and allow the hull to pivot on the bridle's apex at the start of the lift. The 60 ft. tower slip line was rigged to check the tower swing as the hull swung outboard. A 75 ft. buoy deck bail slip line was the most important of all the slip lines. This line prevented the buoy from spinning as the buoy settled out in the water. This is important so that the quick release hook, hanging from the crane's whip, could be released without fouling against the discus tower. The buoy deck bail slip line was removed just following the release of the discus into the sea. One additional line called the whip tag line was used in this operation. This tag line was tied to the crane whip headache ball to help pull the whip away from the tower's meteorological sensors once the quick release hook had been released and the discus cast adrift.

The personnel utilized for this phase of the operation included a deck supervisor, TSE winch operator, two hauling wire handlers, three slip line handlers, a 01 crane operator, a crane whip tag line handler and quick release hook handler.

With all three slip lines in place the crane was directed to swing over the discus buoy. The extension of the crane's boom was approximately 60 ft. The crane's whip was lowered to the discus and the quick release hook attached to the main lifting bail. Slight tension was taken up on the whip to take hold of the buoy. The chain lashing, binding the discus to the deck were removed. The tugger line holding the suspended 40 meters of mooring string up the apex of the discus bridle was eased off to allow the discus to take on that hanging tension. The discus was then raised up and swung outboard as the slip lines kept the hull in check. The bridle slip line was removed first followed by the tower bail slip line. Once the discus had settled into the water (approximately 15 ft. from the side of the ship), and the release hook had gone slack, the quick release hook handler pulled the trip line and cleared the whip away from the buoy (forward) with the help of the whip tag line handler. The slip line to the buoy deck bail should be cleared at about the same time the quick release hook is tripped or slightly before. If the discus were released prior to the buoy settling out in the water the tower could swing into the whip and cause potential damage to the tower sensors. The ship then maneuvered slowly ahead to allow the discus to pass around the stern of the ship.

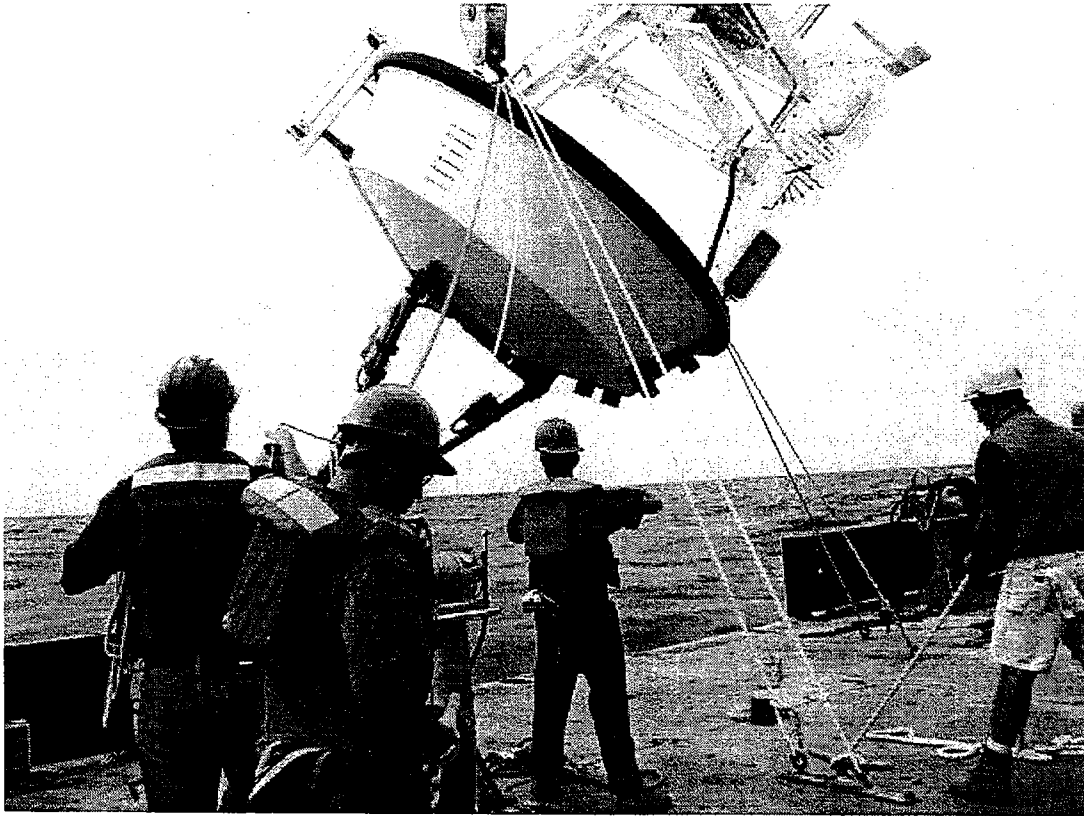

Figure 38: Three slip lines rigged on the discus to maintain constant swing control during the lift.

The TSE winch operator was instructed to slowly haul in the hauling wire once the discus had drifted behind the ship. The ship's speed was increased to 1 kt. through the water in order to maintain a safe distance between the discus and the ship. Once this occurred the bottom end of the 6.2 meter shot of 7/16" wire rope shackled to the hauling wire was hauled in and stopped off at the transom, using a 20 meter length of 3/4" Samson 2 and 1 nylon and a 2 ton snap hook. This line was fair leaded from a 8" snatch block shackled to the front of the winch and back to a deck cleat. The next instrument, 47.5 meter depth Brancker temperature recorder and pre-attached wire shot, 6.2 meter 7/16" wire rope were brought out and shackled to the bitter end of the stopped off wire rope. The free end of 6.2 meter wire rope shackled to the bottom of the Brancker's load bar was then shackled to the free end of hauling wire. The hauling wire was hauled in onto the TSE winch to take up the loose slack of that wire shot. A canvas cover was wrapped around the shackles and termination, before being wound up onto the winch drum. The purpose of the canvas was to encapsulate the shackles and wire rope termination to prevent damage from point loading the lower layers of wire rope and nylon already on the drum. Then TSE winch slowly took up the mooring tension away from the stopper line hooked onto the 6.2 meter wire rope. The line stopper was removed. The TSE winch paid out allowing the Brancker to be eased over the stern. As the bottom end of 6.2 meter wire shot came off the TSE winch drum, the canvas wrap was removed and a stopper line hooked onto the 7/8" end link, which was shackled between the hauling wire and 6.2 meter wire shot. The TSE winch paid out the mooring wire slowly and pulling the stopper line aft to approximately 2 meters from the transom edge. The stopper line was secured to the deck cleat. The TSE winch eased off the mooring

tension to the deck cleat. The hauling wire was unshackled, and the next instrument and wire shot were brought out to the stopped off wire. The process of instrument insertion was repeated for the remaining instruments. As the number of instruments deployed increased so did the mooring tension and it became more difficult to manually lift each instrument over the stern with out potential damage from dropping the instrument onto the deck. To help elevate the mooring wire during wire pay out and instrument deployment over the transom, the ship's jib crane located on the starboard aft quarter was used. The crane was positioned so that the crane's whip hang over the mooring wire 3 meters forward of the transom. A 10" snatch block was hooked onto the crane whip hook. The block was hooked around the mooring wire, forward of the instrument to be deployed. The crane whip was hauled in lifting the mooring wire and instrument so that the mooring wire fleet angle was off the transom edge to allow the instrument to travel over the side unobstructed. The ship's speed during this phase of the mooring operations was approximately 1 to 1.5 kts. Once the remaining instruments had been deployed, the 10 "snatch block was replaced with the WHOI designed, Gifford mooring block to support the long length of wire and nylon line. This block has a large shieve and extra wide throat so that terminations, shackles and rings can pass through it.

The long lengths of wire and nylon were paid out approximately 10% slower than the ship's speed through the water. This was accomplished by using a digital tachometer, Ametek model #1726, to calculate the mooring pay out speed verses the ship's speed through the water. This tool was used as a check to see that the mooring was always being towed slightly during deployment. The selected readout from the tachometer was in miles per hour.

All the mooring wire and nylon on the TSE drum was paid out and the end of the nylon was stopped off to a deck cleat. The mooring was set up for a temporary towing in the following manner. A 5 meter length of 1/2" trawler chain was secured to stopped off nylon end A second stopper line was hooked onto the chain. Both stoppers were eased out so that 1 to 2 meters of the chain shot was past the stern and secured to deck cleats. The speed of the ship was around 1 knot. A Reel-O-Matic tension cart was positioned along side the TSE winch. The last 500 meter length of 7/8" nylon was mounted to the cart. The nylon was fairlead to the TSE winch and wound up onto the drum. The free end of the nylon was shackled to the stopped off 1/2" chain and hauled in, pulling the deployed nylon termination back onto the deck. This termination was stopped off and the towing chain was removed. The nylon terminations were shackled together and pay out continued. The mooring was stopped off 1 meter from the transom using a stopper line.

An H-bit cleat was positioned in front of the TSE winch and secured to the deck. The free end of the 2000 meters shot of nylon / polypropylene line stowed in two wire baskets located against the rag top container was bent around the H-bit and passed on to the stopped off mooring line. Figure 39 and photograph Figure 40 details how this line was reeved around the H-bit. The shackle connection between the two nylon shots was made. The line handler at the H-bit pulled in all the residual slack in the line and held the line tight against the H-bit. The stopper line was then eased off and removed. It was found to be very important to that the H-bit line handler keep the mooring line parallel to the H-bit with constant moderate back tension at all times, while the mooring tension was on the H-bit. The position of the line handler is detailed in photograph Figure 41. The H-bit line handler with the aid of one assistant eased out the mooring line around

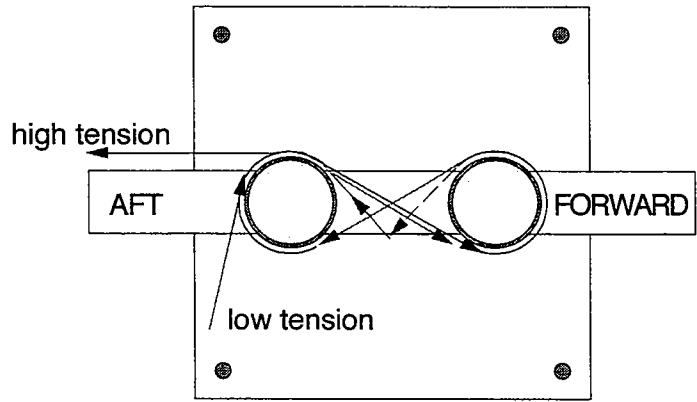

H-Bit line fair lead detail

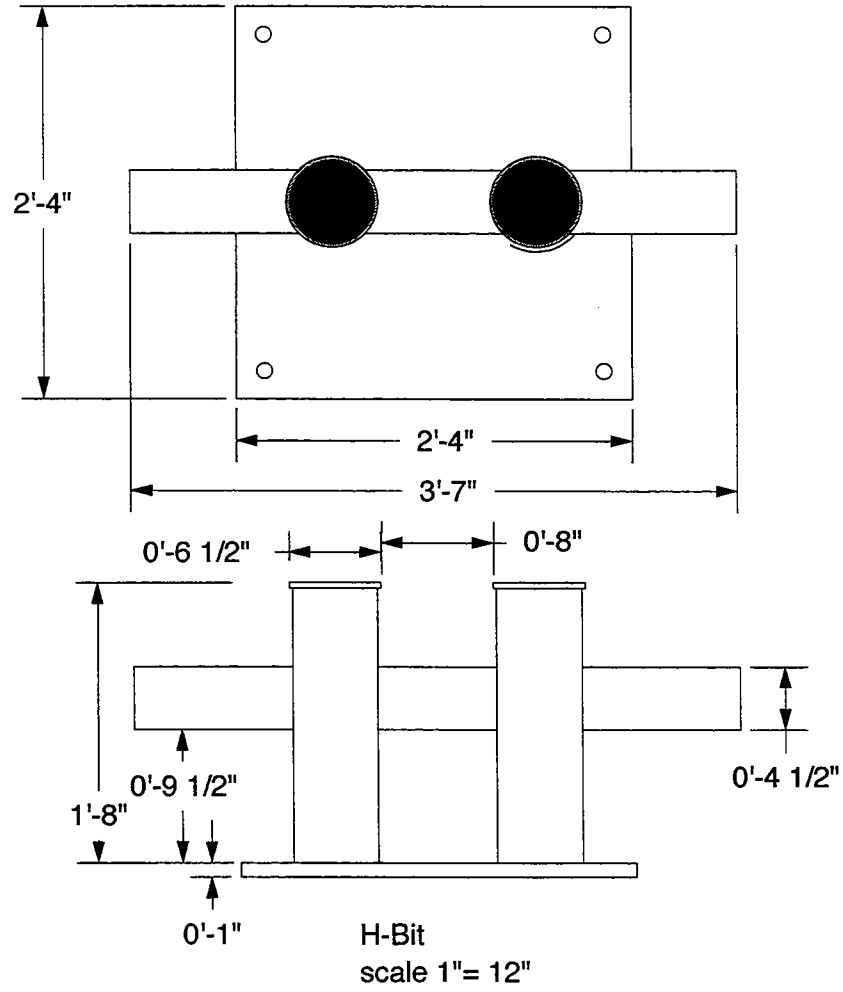

Figure 39: H-Bit winding for releasing the final 2000 m of line.

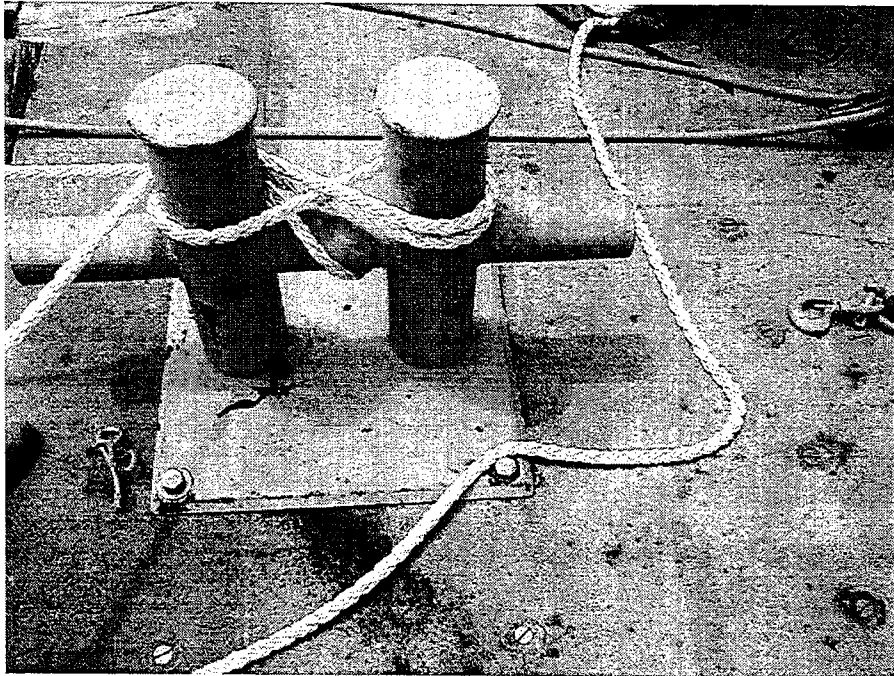

Figure 40: Details how this line was reeved around the H-bit

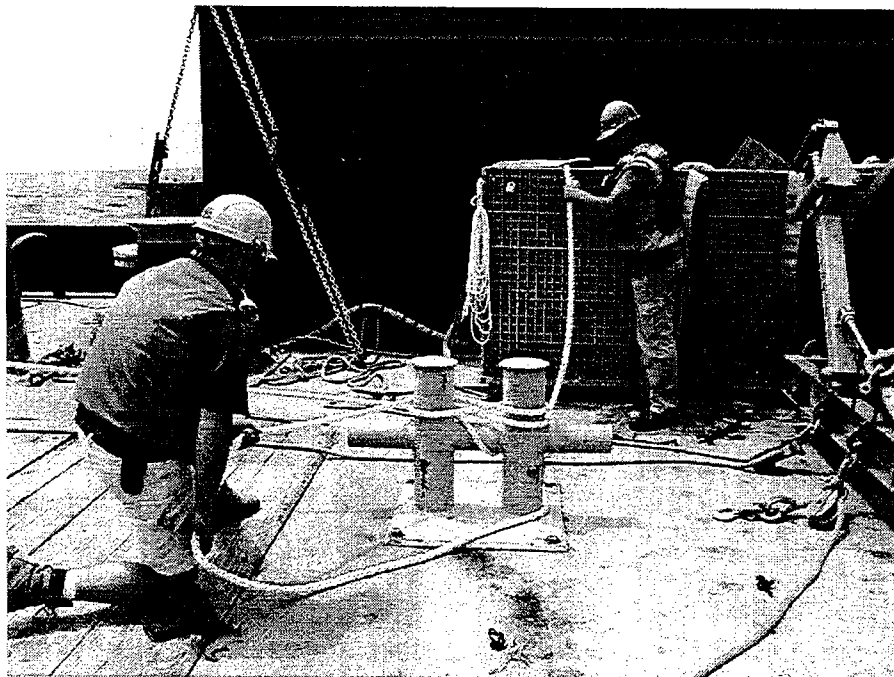

Figure 41: Position of the line handler and assistant.

the H-bit at the appropriate pay out speed relative to the ships speed through the water. While the nylon / polypropylene line was being paid out, the main crane was used to lift out the 81 glass ball out of the rag top container. These balls were staged fore and aft in 16 ball segments, aft of the starboard A-frame Figure 42. Once the end of the polypropylene line was reached pay out was stopped and a length of 3/4" line was tied to the high tension side of the polypropylene line using a timber hitch knot. This line was than secured to a deck cleat. Another length of line was tied to the end thimble of polypropylene line, to be used as a safety checking line as the mooring line was eased around the H-bit. The TSE winch tag line was shackled to the end of the polypropylene line. The winch line and mooring line were wound up taking the mooring tension away from the timber hitched stopper line. The stopper line was removed. The TSE winch paid out the mooring line so that its thimble was approximately 1 meter from the ship's transom.

The deployment of the 81 - 17" glass balls was accomplished by using two 20 meter long 3/4" Sampson stopper lines fitted with 2 ton snap hooks, fair leaded through two 8" snatch blocks secured to the front of the TSE winch. This configuration of the deck stopper fair lead allowed for the maximum available distance between the TSE winch and the transom while keeping the mooring components centered in the front of TSE winch. The 81 glass balls were bolted on 1/2" trawler chain in 4 ball / 4 meter increments. As the glass balls were slung out of the rag top container, they were separated into 5 strings, approximately 16 meters long. The first sting of glass balls was dragged aft up to the stopped off polypropylene line. The free end of the glass ball string was then shackled onto the mooring line. The glass balls were stretched out up to the front of the winch. A stopper line with a 2 ton snap hook was hooked onto a end link

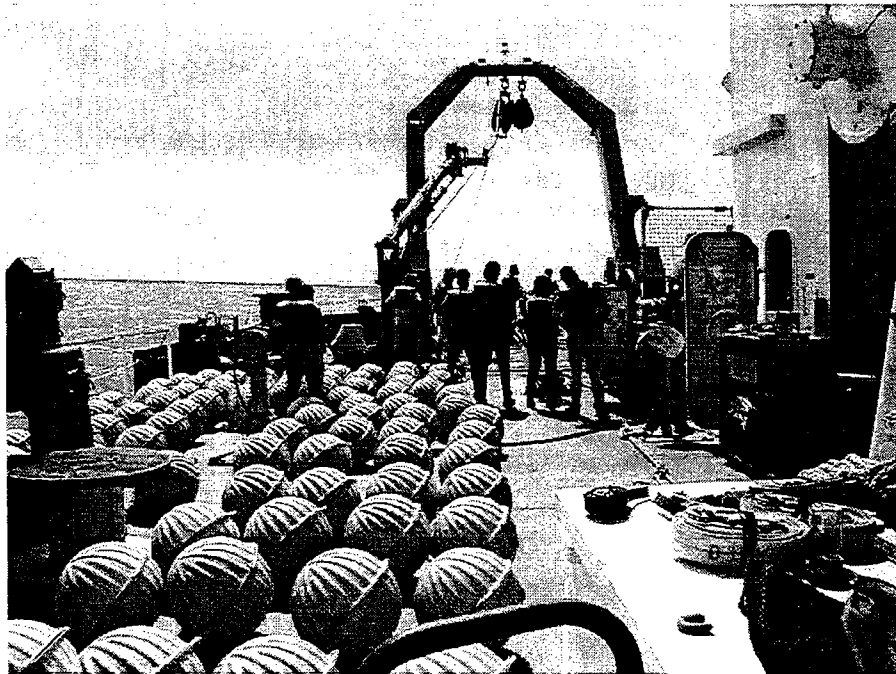

Figure 42: Eighty-one glass balls in hard hats stowed on deck for deployment.

positioned closest to the front of the winch and the line brought up tight and secured to a deck cleat. The stopper which was holding the mooring tension at the transom was then eased off allowing the load to shift to the forward stopper line. This stopper was slowly paid out as several deck personnel assist in dragging the remaining glass ball aft along the side of the TSE winch aft. The stopper line was paid out so that the adjacent glass ball out board of the stopper's hook remained on deck with a segment of 1/2" trawler chain bent over the deck edge. The stopper line was secured to the deck. The free stopper line again hooked onto the closest shackle, end link, shackle joint closest to the TSE winch. Tension was pulled up, and the line cleated, then the aft stopper line was eased off and removed. The next 16 glass ball segment was pull aft and shackled onto the end of the stopped off glass balls and the swapping stopper lines technique repeated so that the 5 meter length of 1/2" trawler chain shackled to the last ball string was stopped off 1 meter from the transom. The deck supervisor made a conscious effort to make sure that the snap hooks were hooked and deck cleats were reeved correctly during the glass ball phase of the deployment.

The two acoustic releases and attached 1/2" trawler chain segments were deployed using a air tugger hauling line revved through a block hung in the Aframe and the TSE winch. Shackled to the end of tugger line was a 1/2" chain grab. The 20 meter 1" Samson anchor pennant was shackled to the TSE winch tag line and pre-wound onto the winch drum. The test B.A.C.S. acoustic release was positioned on the fantail 1 meter from the transom. The stopped off 5 meter length of 1/2" trawler chain was shackled to the top of the release. A 5 meter length of 1/2" chain was shackled to the bottom of release and the loose end of the chain secured to the anchor pennant. The Aframe was positioned so that the hanging air tugger line and chain grab was over the top end of the release. The tugger line was lowered and hooked onto the 1/2" chain approximately 1 meter from the bottom end of the release. The anchor pennant was drawn up so that all available slack in the line was taken up on the winch drum. The tugger line was hauled in lifting the release 1.5 meters off the deck. The Aframe was shifted out board with the TSE winch slowly paying out its line. The tugger line hauled in and paid out during this shift out board in order to keep the release off the deck as the instrument passed over the transom. Once the release had cleared the deck, the TSE winch pay out was stopped and the tugger line was removed. The 5 meter 1/2" chain was then stopped off with a stopper line and the anchor pennant was removed. The EGG acoustic release was positioned, rigged and deployed in a similar fashion.

If there had been a need to tow the mooring for a period of time in order to reach an appropriate depth or location the mooring would have been rigged for towing from the after 5 meter shot of trawler chain secured to the release. In this instance the depth was acceptable for the mooring design so the anchor pennant was paid out with deck personnel holding chafing gear around the line, where the line bent over the transom. The 5 meter, 1/2" chain shackled to the anchor was lead out over the stern and back onto the deck. The bottom end of the pennant was paid out parallel to the end of the 1/2" trawler chain. The free end of the 1/2" chain was then shackled to the stopped off end link. A 1/2" screw pin shackle and a 5/8" pear ring were as well secured end link. A deck cleat was bolted to the deck positioned fore and aft 1 meter forward of the stopped off anchor pennant. This deck cleat was bolted down with a 1" eye bolt positioned on its aft end. A 20 meter length 3/4" Samson line was bent through the 5/8" pear ring and one of its free ends tied in a bowline on to the cleat's eye bolt. The free end of the line was pull tight and secured onto the horns of the cleat. The TSE winch tag line was eased off and removed. The

01 crane was shifted so that the crane whip would hang over and slightly aft of the anchor. The whip was lowered and the whip hook secured to the tip plate chain bridle. A slight strain was applied to the bridle. The chain lashings were removed from the anchor. The Samson line was slipped off transferring the mooring tension to the 1/2" chain and anchor. The line was pulled clear and the crane whip raised 0.5 meters lifting the forward side of the tip plate causing the anchor to slide over board.

APPENDIX 6: STRATUS ANTIFOULING COATING TEST

Erosion Rate Study of No Foul SN-1 on STRATUS Discus Buoy

W. Ostrom - WHOI

M. Alex Walsh – E Paint Company, Inc.

The STRATUS discus hull was used as platform to evaluate two antifouling paints in an ongoing test to evaluate antifouling paints suitable for moored aluminum buoy hulls and subsurface instrumentation positioned in the photic zone. The Upper Oceans Processes group has traditionally relied on organotin-based antifouling paints such as Amercoat #635 (Ameron International Protective Coatings Group) and Micron 33 (International Paint). However, this class of antifouling paint has been banned by the International Maritime Organization (IMO), with use of these products phased out by 2003. Fears of an imminent ban of organotin antifouling paints as well as environmental and toxicological concerns with their use prompted members of the Upper Oceans Processes group to identify alternatives. Work began in the early 90's to identify an environmentally compliant replacement. Years of foul-resistance testing using discus and guard buoys as platforms moored throughout the world have identified an effective replacement for organotin antifouling paints, No Foul SN-1® manufactured by E Paint Company, Inc. Instead of the age-old method of leaching toxic heavy metals, the patented No Foul® approach takes visible light and oxygen in water to create peroxides that inhibit the settling of fouling organisms. Photogeneration of peroxides and the addition of an organic cobioicide, which rapidly degrades in water to benign by-products, make No Foul SN-1 an effective alternative to organotin antifouling paints. Prolonged service life of No Foul SN-1, 2-3 years or equal to organotin-based antifoulants, has not been demonstrated scientifically. This research effort investigates the erosion characteristics of two No Foul SN-1 formulations in an attempt to correlate erosion rates with service life.

To compare erosion rate over time three products were tested, No Foul SN-1, No Foul SN-1⁺ and Micron 33. Micron 33 was used as a comparative control. No Foul SN-1 has been repetitively tested in the field and has shown good bonding and antifouling characteristics as well as a demonstrated service exceeding 8 months (UOP technical report 98-02 page 98-101). It was concluded from this study that "No Foul SN-1, with adequate mil thickness, will perform as well as tributyltin based antifouling antifoulants". Because of the extended deployment period of 12 months for the STRATUS mooring, an experimental formulation, SN-1⁺ was included in this study. This version of the product is reported to ablate at a slower rate due to the addition of an UV stabilizer to the formula. Degradation from exposure to ultraviolet light is the primary reason for rapid erosion on treat substrates positioned in the photic zone. The addition of a stabilizer to SN-1⁺ consequently should reduce the erosion rate and provide a longer service life.

The discus hull bottom was painted in the following manner. The hull's bottom was first lightly sanded to remove loose debris and provide a coarse substrate for application of one coat of a high build epoxy primer, Devoe's Bar-Rust 235. This coating was applied to act as a tie-coat between residual antifouling coatings still remaining on the discus hull and the new formulations used for this study. The color of the primer was light gray. While the epoxy tie-coat was tack-

free but soft to finger pressure, as recommended by the manufacturer, the first coats of No Foul SN-1 were applied.

The hull of the discus buoy was sectioned off so that the SN-1 and SN-1+ were painted on opposite sides. Immediately adjacent to each sample area, a 4" wide strip was left unprotected to act as the control for the test. Between two unprotected control strips, running along the center of the discus bottom, Micron 33 was applied as a comparative control. The paint scheme is detailed in Figure 43. The weights of each paint applied per cm² were measured in grams and the coating thickness estimated. Table 15 below details the weight of each sample applied per unit area, estimated film thickness and dates of application.

All the test coatings upon the conclusion of the test will be photographed and film thickness testing conducted to determine the erosion rates over time. The types and degree of fouling present on discus hull upon recovery will be documented.

In addition to the discus buoy, instrumentation was also treated with antifouling coatings. Table 16 below details the preventive measures taken in protecting the subsurface instrumentation against bio-fouling.

Table 15: Weights per unit area and estimated film thickness of antifouling paints applied to the STRATUS discus buoy.

PAINTS APPLIED (Inrespectiveorder)	DATE	COLOR	SECTION A			
			Chine wt(g)/cm ²	mils(dft)	Bottom wt(g)/cm ²	mils(dft)
No Foul SN-1	24-Jul-00	WHITE	0.02	2	0.02	2
No Foul SN-1	25-Jul-00	GRAY	0.05	4	0.03	3
No Foul SN-1	26-Jul-00	BLUE	0.03	3		
No Foul SN-1	27-Jul-00	BLUE	0.03	3	0.02	2
SECTION B						
No Foul SN-1 ⁺	24-Jul-00	WHITE	0.03	<1		
No Foul SN-1 ⁺	24-Jul-00	GRAY	0.04	2		
No Foul SN-1 ⁺	25-Jul-00	BLUE	n/d	2		
No Foul SN-1	25-Jul-00	BLUE	0.02	2	0.02	2
No Foul SN-1	26-Jul-00	BLUE	0.03	3	0.03	3
No Foul SN-1	27-Jul-00	BLUE	0.03	3	0.03	3
No Foul SN-1	27-Jul-00	BLUE			0.02	2
No Foul SN-1	1-Oct-00	WHITE	n/d	5	n/d	5

Table 16: Information regarding the antifoulants applied to instrumentation.

Instrument	Paint	Color	# coats/mils (dft)	Application	Date Applied
VMCM cage	SN-1	white	2/6mils.	spray	Aug-00
VMCM sting	SN-1	white	1/3mils.	spray	Aug-00
VMCM fans	SN-1	white	1/3mils.	spray	Aug-00
VMCM assembled	TempoTBT	clear	1/3mils.	spray	Oct-00
MicroCat trawl guard	SN-1	white	1/3mils.	spray	Oct-00
MicroCat trawl guard	TempoTBT	clear	1/3mils.	spray	Oct-00
SEACAT trawl guard	SN-1	white	1/3mils.	spray	Oct-00
SEACAT trawl guard	TempoTBT	clear	1/3mils.	spray	Oct-00
SEACAT sensor shield	SN-1	white	1/3mils.	spray	Oct-00
Brancker thermister	SN-1	white	3/3mils.	brush	Oct-00
Brancker trawl guard	SN-1	white	1/3mils.	spray	Oct-00
Brancker trawl guard	TempoTBT	clear	1/3mils.	spray	Oct-00
Chlam cage	SN-1	white	2/6mils.	spray	Aug-00
Rain gauge	TempoTBT	clear	1/3mils.	spray	Oct-00
FSST frame	SN-1	white	2/6mils.	brush	Oct-00
FSST frame assembled	TempoTBT	clear	1/3mils.	spray	Oct-00
Discus bridle legs	SN-1	white	3/9mils.	brush	Oct-00
Discus bridle legs	SN-1	blue	1/3mils.	brush	Oct-00

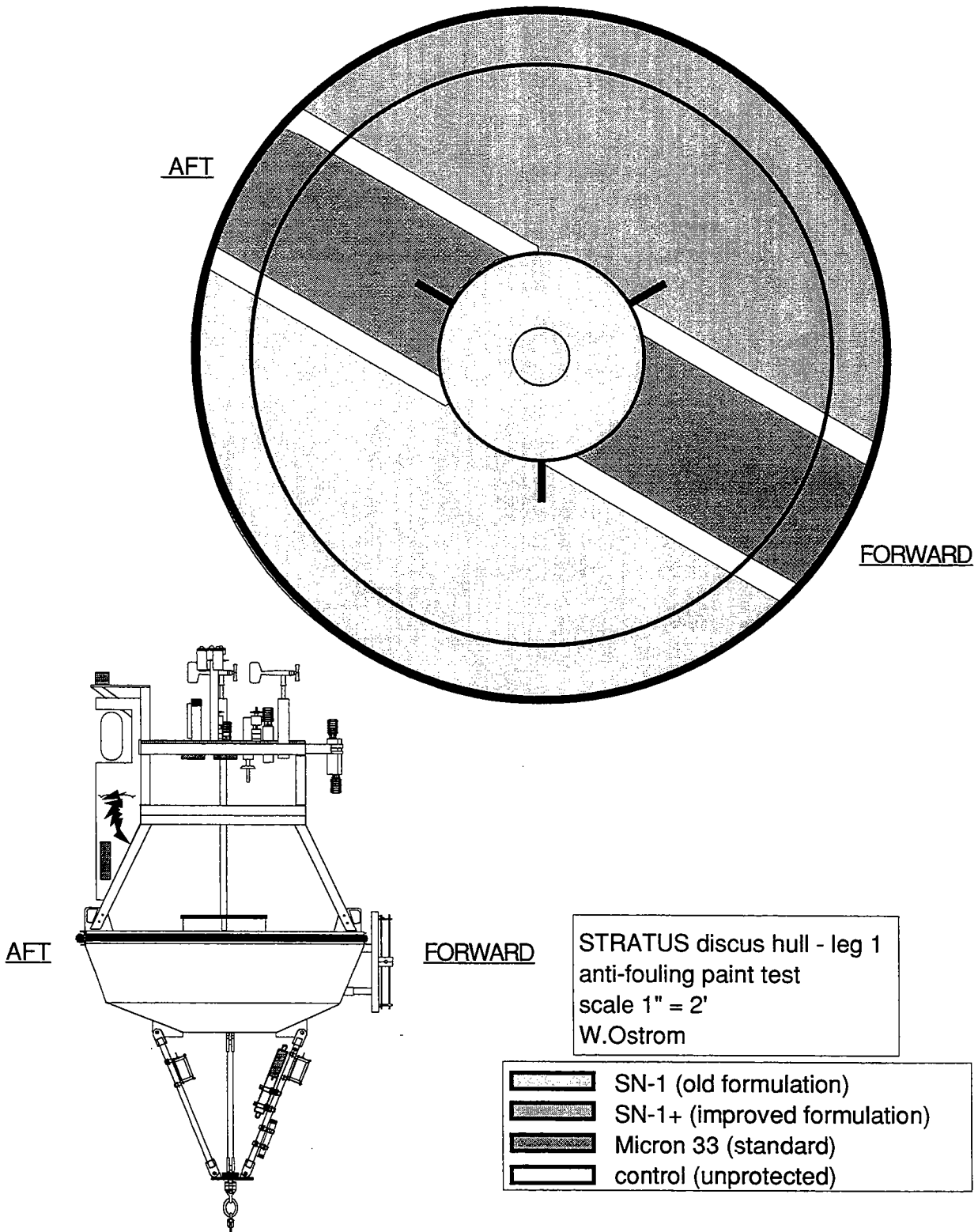

Figure 43: Diagram of the Discus Buoy and Painting Scheme

Appendix 7: Shipboard Air-Sea Flux System Procedure Details

A sonic anemometer system for measuring turbulent wind flux (son-flux system) was mounted on the jackstaff on the bow of the R/V *Melville*. The system was developed at WHOI by Jim Edson, Jon Ware, and Bob Weller. The sensor system mounted on the mast consisted of a Gill R3A Ultrasonic Anemometer, a Crossbow DMU-AHRS motion sensing unit, and an Onset TT8 interface. From the mast, a cable ran to an interface box which connected to a PC computer and two power supplies. The cable supplied power to the instrument and was also used for continual real-time data uploading to the PC. The logging software (Son_flux) was developed at WHOI by Jon Ware and Ed Hobart.

There are two calibration procedures for the DMU: zeroing of the rate sensor while tied to the dock, and a hard iron calibration routine while the ship is underway. These are performed using the Crosscut terminal program.

The data files recorded by the Son_flux software are named DDDSSSS.C1 where DDD is yearday and SSSS is the time of day (UTC) in seconds when the data in the file begins. The data files are written at intervals specified by the operator at the time when data acquisition is initiated. Usually there is between 1 minute and 1 hour of data points per file. (Few-minute files in testing mode; 1-hour files during actual deployment.)

September 28, 2000, in warehouse in Arica:

14:48:30 Set the PC clock to UTC.
16:35 Started son-flux system logging with 1-hour files.
16:41 Stopped logging. Everything looked fine with the real-time data display.
16:42 Started logging with 2-minute files. File name did switch over as scheduled.
16:49 Stopped logging.
16:56 Started logging with 1-minute files.
17:32 Stopped logging.

Checked calibration commands were working: in Crosscut,
entered "ze" and got "Z0" response
entered "d" and got "D" response
entered "e" and got "E" response

19:10 Started logging with 3-minute files.
19:16 Stopped logging. Everything ready to go until getting on the ship.

September 29, 2000, on board R/V *Melville* tied to Arica dock:

Jim Ryder and Will Ostrom mounted the instrument on the mast. "N" markings on the instrument case were aligned as closely as possible by eye to point forward along the midline of the ship. The underside of the large channel in the mounting bracket was 41' 4" above the water. This was before the UOP mooring equipment was loaded onto the ship, which would have decreased the height of the instrument above the water. A digital level sitting flat in the channel of the mounting bracket read between 0.2-0.3 deg down when parallel to the ship's centerline,

and 2.3-3.0 deg up when perpendicular to the ship's centerline. The uncertainty in these measurements is due to the movement of the ship while tied to the dock.

The computer, interface box, and power supplies were located in the science chart room.

23:36 Zeroed rate sensor. No hard iron calibration (ship not underway until October 2, 2000).

23:42 Started logging with 1-hour files.

October 1, 2000, on board R/V *Melville* tied to Arica dock:

22:17 Stopped logging in order to install surge protector.

22:22 Started logging with 1-hour files.

October 2, 2000, on board R/V *Melville* tied to Arica dock:

15:12 Stopped logging to re-zero rate sensor. Lots of horizontal surge at this dock - trying for a better zero since ship was not still in the water last time rate sensor was zeroed.

15:16 Started logging with 1-hour files.

22:00 (approximately) R/V *Melville* departed Arica.

October 2, 2000, on board R/V *Melville* underway to mooring site:

22:46 Stopped logging to do hard iron calibration.

22:51 Started 720 deg rotation of ship.

23:12 Finished ship rotation. DMU did not respond to "e" command within several minutes.

23:13 Trying ship rotation again.

23:35 Finished 720 deg rotation. DMU still did not respond.

Tried giving "d" command to DMU (got "D" response) followed immediately by "e" command. DMU did respond correctly ("E") this time. Apparently DMU timed out during the ship rotation.

23:39 Started logging again without successful hard iron calibration.

(Did not set hard iron calibration constants to zero.)

October 6, 2000

Email from Jim Edson: the hard iron correction to the DMU's magnetic compass can be done after the cruise using the ship's gyro compass data, which John Chatwood says is being recorded at least once per minute.

October 7, 2000, on board R/V *Melville* departing mooring site:

22:41 Stopped logging to try hard iron calibration again, spinning ship faster.

22:46 Started calibration.

22:48 Stopped with incomplete calibration; ship not spinning fast enough yet.

22:50 Started calibration again.

22:56 Finished spinning ship 720 deg. Stopped calibration. No "E" response from DMU.

23:05 Still no response from DMU. Gave up on hard iron calibration.

23:08 Set hard iron calibration constants to zero with "h" command.

23:10 Started logging.

Jon Ware says Crossbow manufacturers recommend less than 2 minutes spinning time for the ship, but Captain says even with bow thruster (not used here) the ship cannot spin any faster.

Appendix 8: Data collected during the Cook 02 Cruise on the R/V *Melville*

SIO Data Files: Content, Format, Decoding

SeaBeam, Gravity, and Navigation Shipboard Data

The underway SeaBeam, gravity, and navigation data are recorded to the R/V *Melville's* main computer log files in 1-minute intervals. Each record includes the GPS (PCODE) time and location, ship speed and heading, the water depth from center beam of the SeaBeam, and gravity from the gravimeter. The underway file is traditionally kept in the UWMGR/ directory and is in ASCII format. It has a file name that is list.uwmrg.<cruise>, where yy is the two digit year, mm is the two digit month, dd is the two digit date, and <cruise> means the name of the cruise (e.g., cook02mv). The files are in space separated, formatted, ASCII format. The column headers are: Day, Time (GMT), Latitude Deg, Min, Longitude Deg, Min., Course (Deg), Speed (Kts), Cum.Dist N.Miles, SeaBeam (Meters - Generic 1500m/s Sound Vel correction), SeaBeam (Meters - With Specific Sound Vel. Corrected), Magnetics Obsv, Mag. Anom, Gravity Obsv, Grav. Anom, Record In File. The data recorded during the Cook02 leg are shown in Figure 1 through Figure 46. The full multi-beam SeaBeam mapping data are contained in the directories that begin with SB*. Software to read and produce the SeaBeam maps is located here: http://www.ldeo.columbia.edu/MB-System/html/mbsystem_home.html.

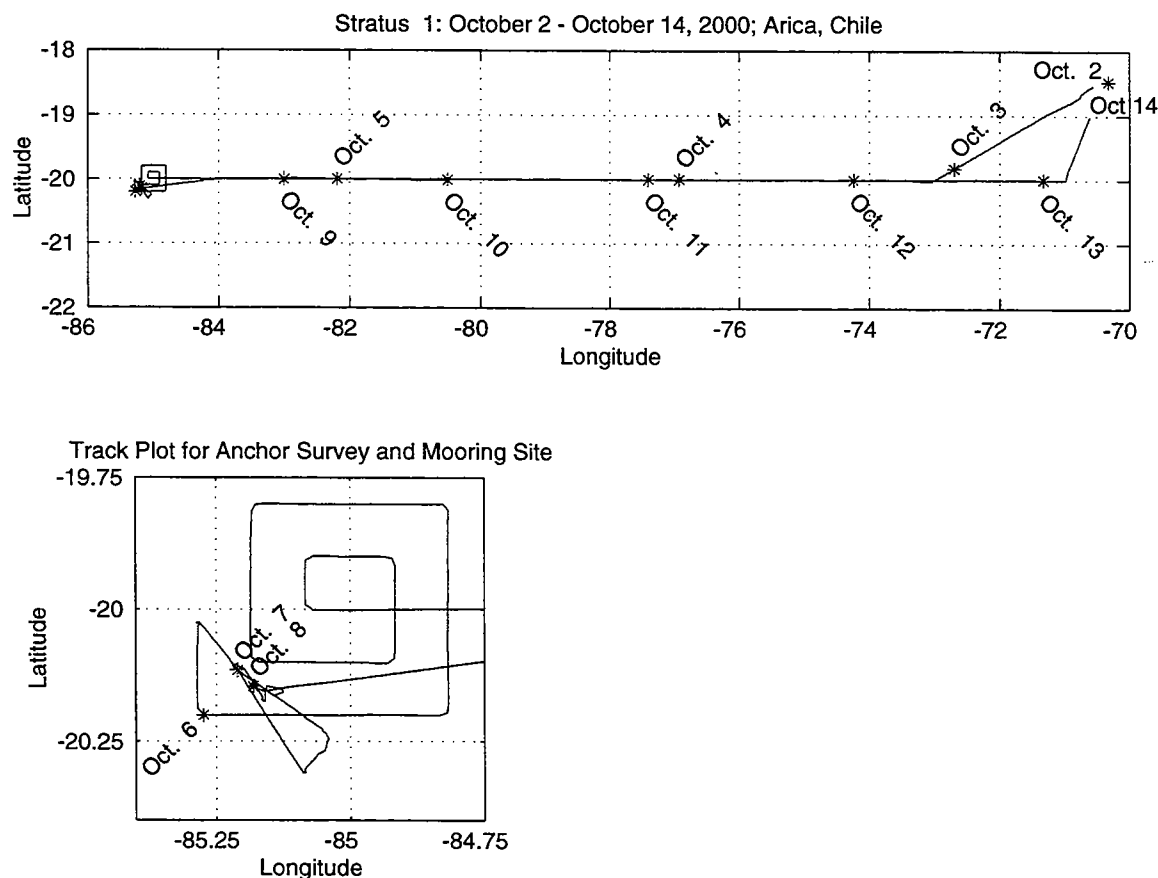

Figure 44: Track plot of the STRATUS 1 cruise. Positions are marked for noon local time.

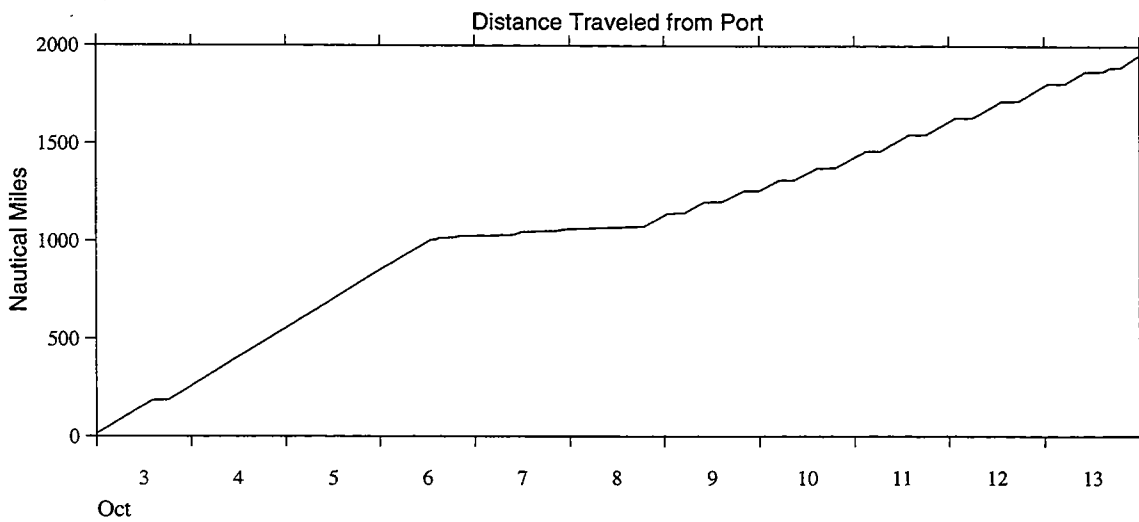
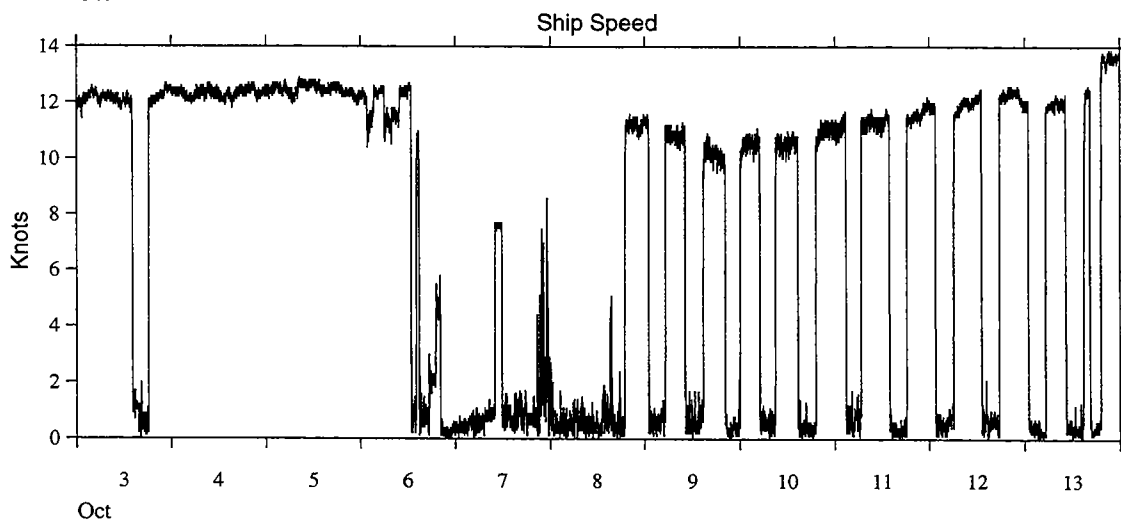
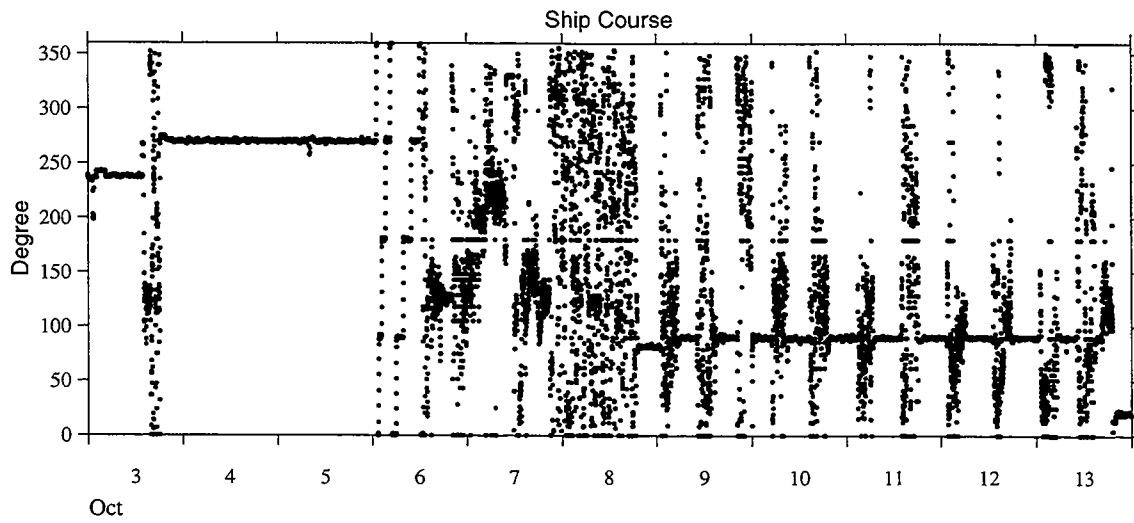

Figure 45: Ship Course, Speed, and Distance Traveled (by Date)

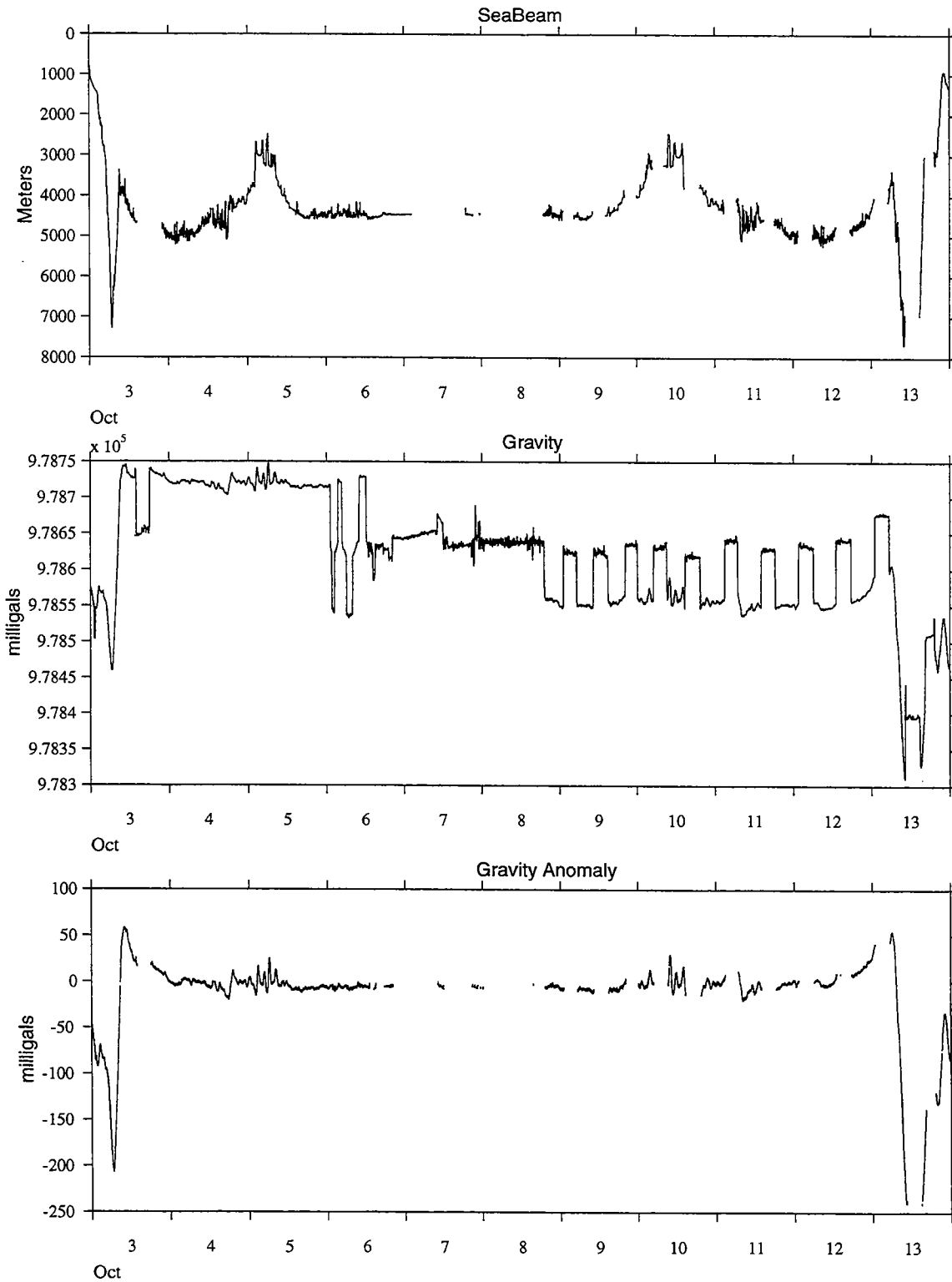

Figure 46: SeaBeam Water Depth, Gravity, and Gravity Anomaly (by Date)

Shipboard ADCP, Zonal and Meridional currents.

The RD Instruments vessel mounted Acoustic Doppler Current Profiler (ADCP) recorded the zonal (U – East) and Meridional (V- North) vector current velocities during the Cook02 cruise. The data is stored in the standard RDI ADCP binary format pingdata.###. These files were decoded using the information available from http://www.ncdc.noaa.gov/coare/catalog/data/ocean_large_scale/adcp_coare.html and free software from CODAS (<ftp://noio.soest.hawaii.edu/pub/codas3/> - see the README file and ping2mat program). The converted pingdata and the corresponding current velocities are shown in Figure 47.

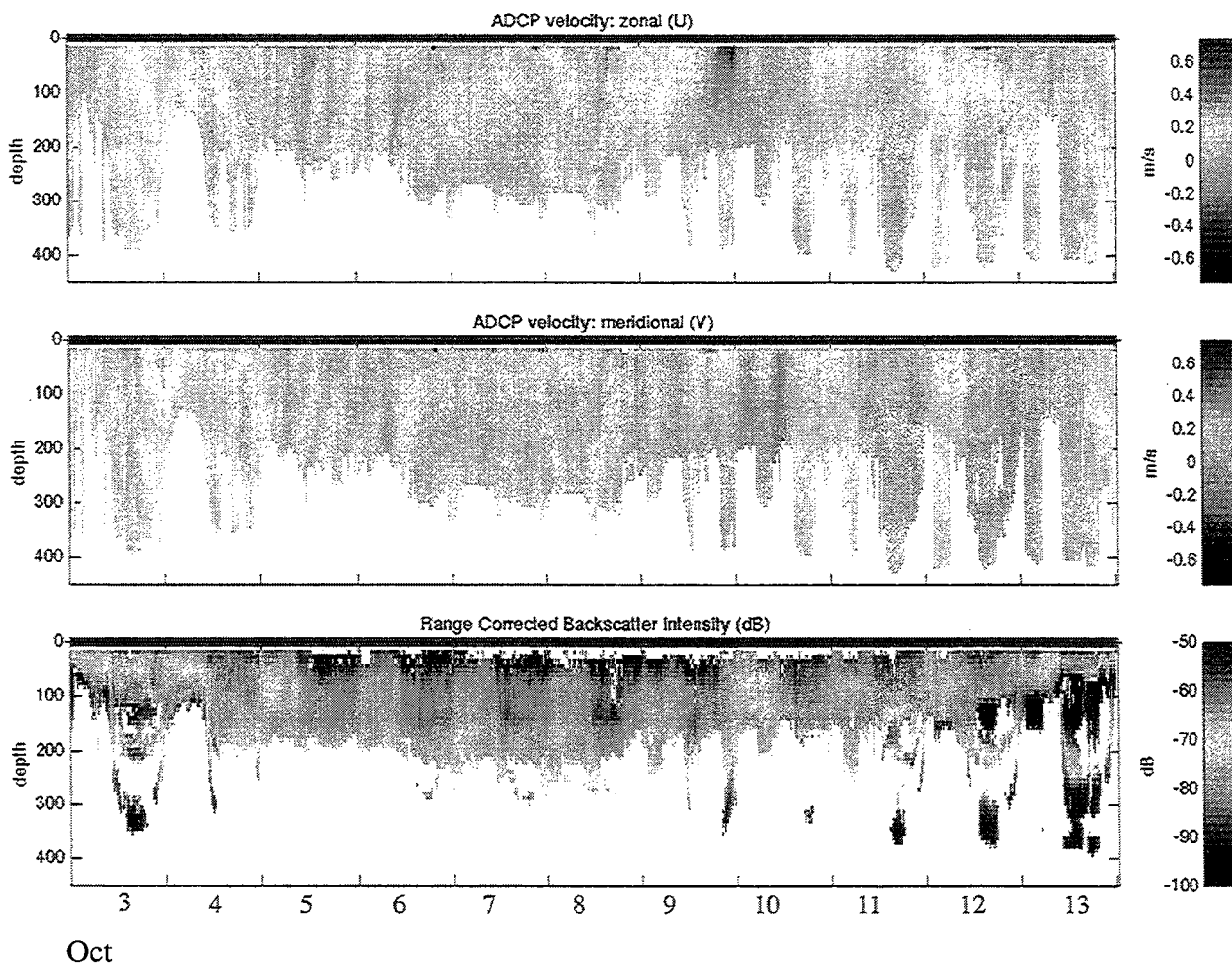

Figure 47: Zonal and Meridional Currents for the Shipboard ADCP.

Shipboard IMET and Thermo-Salinograph sensors

The meteorological and oceanographic data sampled by the IMET and Thermo-Salinograph instruments are recorded to the R/V *Melville's* main computer log files. Each record includes the IMET data with radiation and wind, Thermo-Salinograph data, GPS (PCODE) time and location, and ship speed and heading. These files are traditionally kept in the MET/ directory and are in ASCII format. They have file names that are yymmdd.dat.Z, where yy is the two digit year, mm is the two digit month, dd is the two digit date, and the Z means that the file is compressed.

Unfortunately, due to a computer network error during the Cook02 leg the MET/ files were produced with mostly bad value flagged data. To compensate for this error we used the raw IMET data that was recorded to the IMET logging computer approximately every 30 seconds. These files are comma separated, ASCII format. File names are of the format yymmdd.SCR. The column headers are: \$WISCR, day, month, year, hour, minute, second, AT, BP, RH, AT_RH, DP, PRC, WN (wind speed, kts, relative to ship), WD (wind direction, relative to ship), SW, LW, LW_DOME, LW_BODY, LW_TPILE, SST, SSC (conductivity, mmho), FLOW, SAL (psu), SIG_T, SOUND_VEL, LAT, LON. IMET and Thermo-Salinograph data are shown in Figure 48 through Figure 51.

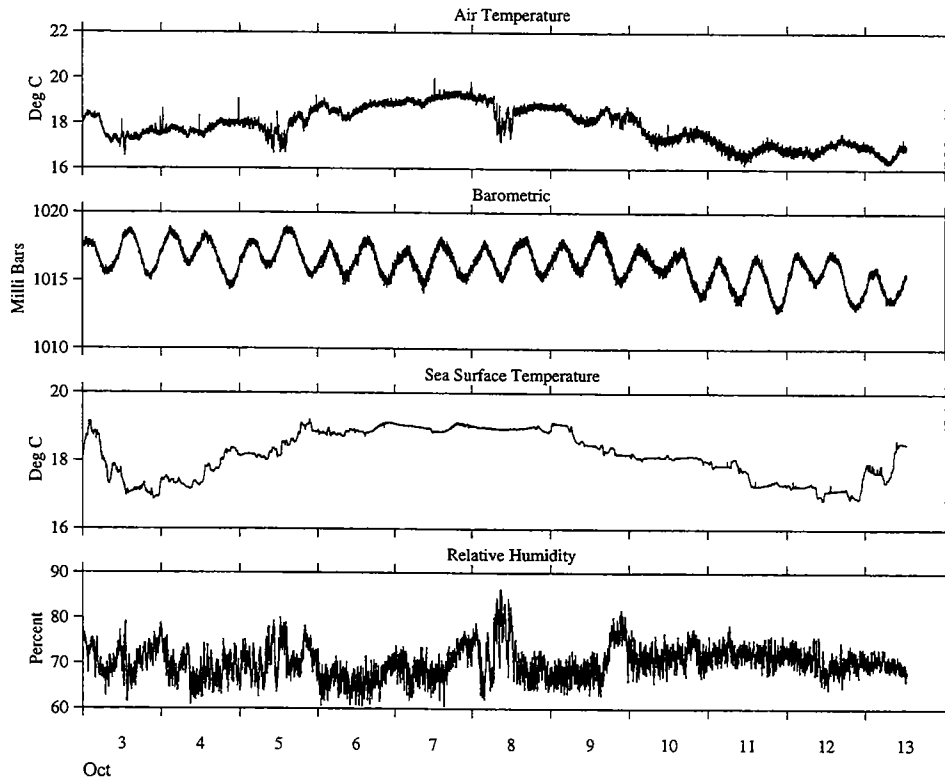

Figure 48: Air Temperature, Barometric Pressure, SST, and Relative Humidity from Shipboard IMET sensors.

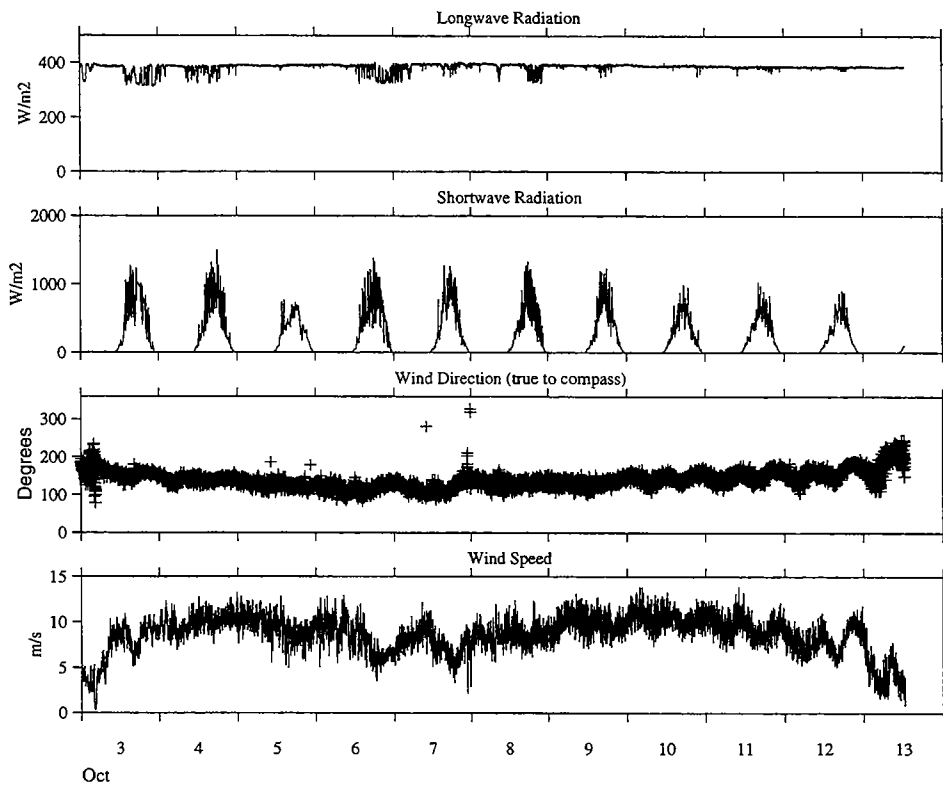

Figure 49: Longwave and Shortwave radiation, Wind speed and direction.

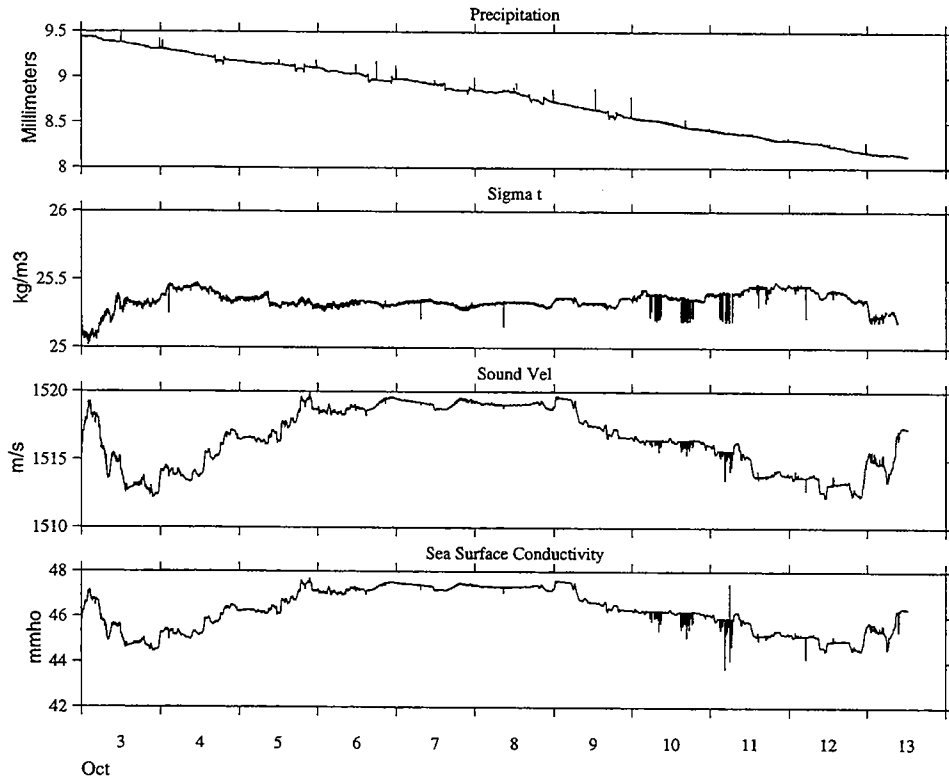

Figure 50: Precipitation, Sigma t, Sound velocity, and Sea surface conductivity.

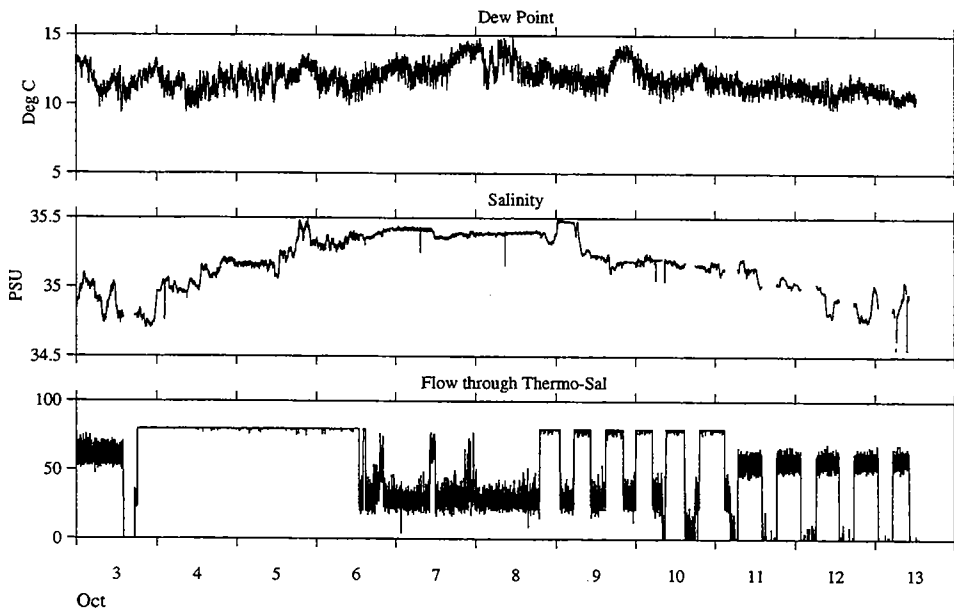

Figure 51: Dew Point, Sea Surface Salinity, and Flow through the Thermo-Sal.

ASIMET Longwave Radiation, Relative Humidity, Air Temperature, and Incoming Shortwave Radiation

ASIMET longwave radiation, relative humidity, air temperature, and incoming shortwave radiation sensors were placed on the 03 deck of the R/V *Melville* (see Section 2-C for details). The data recorded from these instruments are shown in Figure 52 and Figure 53. The binary data was converted to ASCII, standard WHOI ASIMET format. The format is described as follows:

Humidity with Air Temperature: Each ASCII line contains a time stamp (hour, minute, second), date stamp (day, day of the week – Sunday=7, month, year), one hour worth of 1-minute data for humidity (60 continuous samples), one hour worth of 1-minute data for air temperature (60 continuous samples), separated with commas.

Longwave Radiation: Each ASCII line contains a time stamp, date stamp, one hour worth of 1-minute data for the body temperature, one hour worth of 1-minute data for dome temperature, one hour worth of 1-minute data for thermopile voltage, and one hour worth of 1-minute data for the computed longwave radiation.

Shortwave Radiation: Each ASCII line contains a time stamp, date stamp, one hour worth of 1-minute data for shortwave radiation.

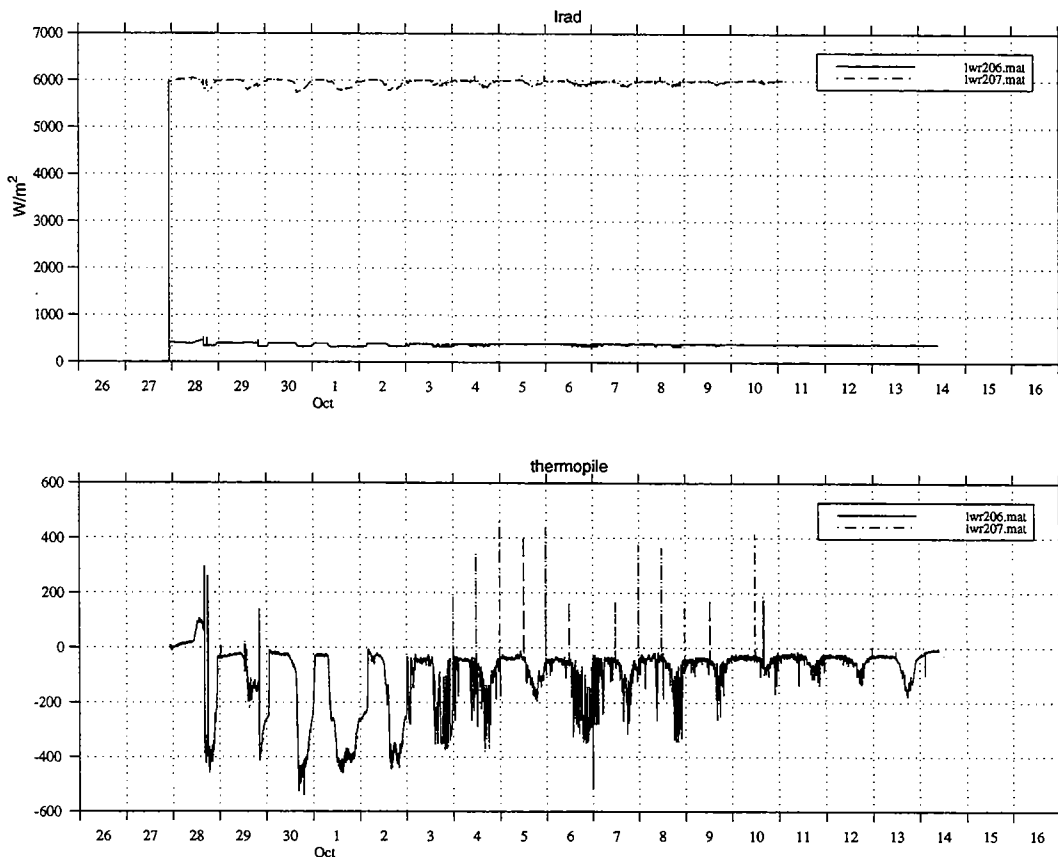

Figure 52: ASIMET Longwave Radiation (shown with Thermopile voltage).

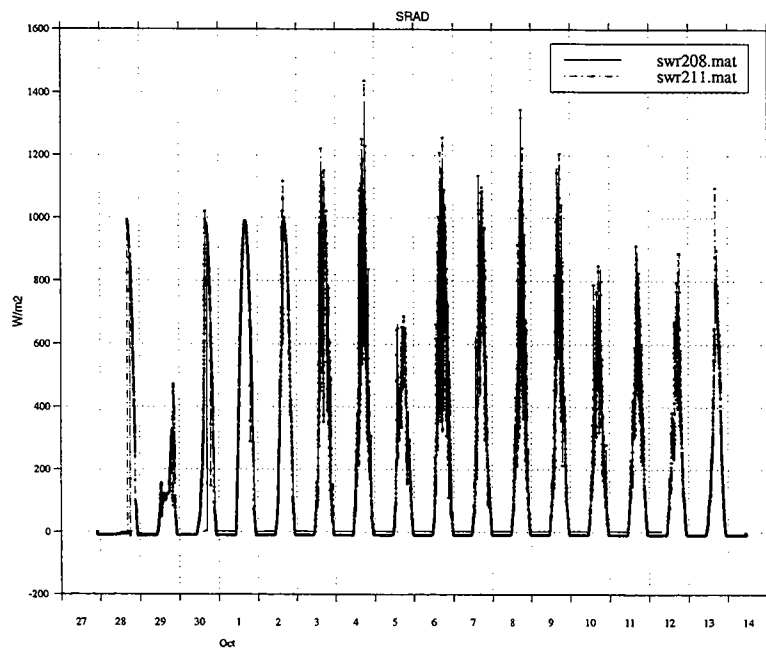
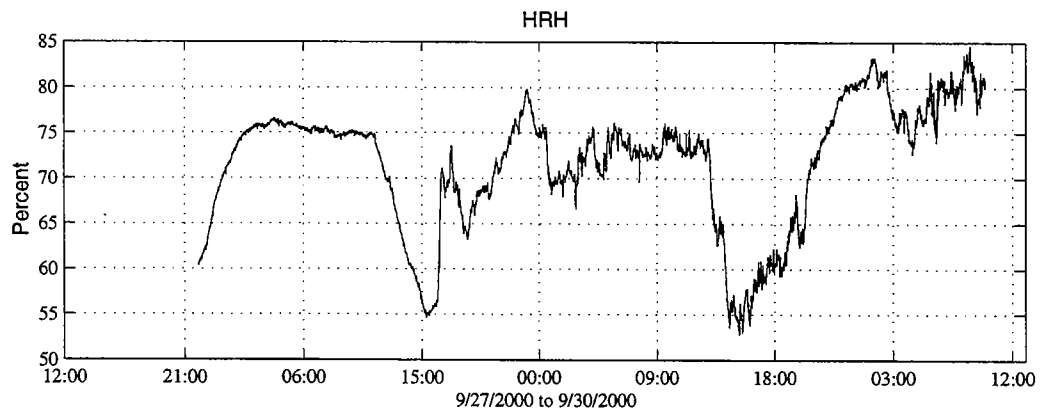
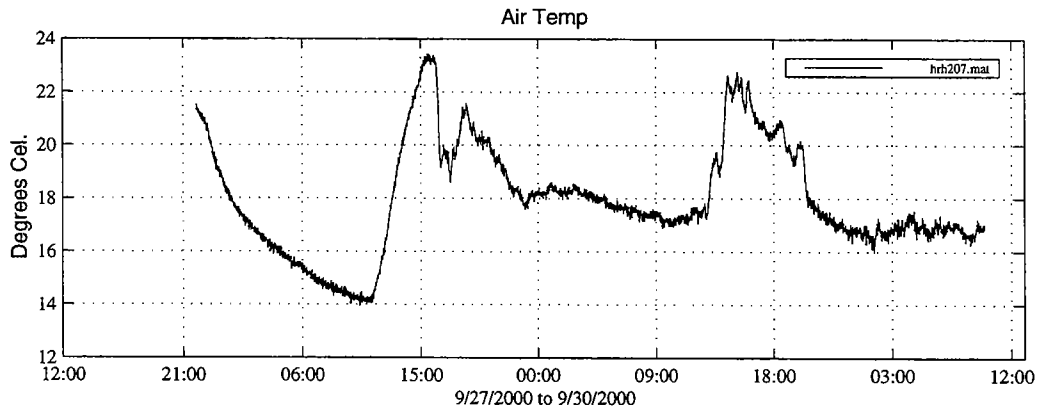

Figure 53: ASIMET Relative Humidity and Shortwave Radiation.

DOCUMENT LIBRARY

Distribution List for Technical Report Exchange – July 1998

University of California, San Diego
SIO Library 0175C
9500 Gilman Drive
La Jolla, CA 92093-0175

Hancock Library of Biology & Oceanography
Alan Hancock Laboratory
University of Southern California
University Park
Los Angeles, CA 90089-0371

Gifts & Exchanges
Library
Bedford Institute of Oceanography
P.O. Box 1006
Dartmouth, NS, B2Y 4A2, CANADA

NOAA/EDIS Miami Library Center
4301 Rickenbacker Causeway
Miami, FL 33149

Research Library
U.S. Army Corps of Engineers
Waterways Experiment Station
3909 Halls Ferry Road
Vicksburg, MS 39180-6199

Marine Resources Information Center
Building E38-320
MIT
Cambridge, MA 02139

Library
Lamont-Doherty Geological Observatory
Columbia University
Palisades, NY 10964

Library
Serials Department
Oregon State University
Corvallis, OR 97331

Pell Marine Science Library
University of Rhode Island
Narragansett Bay Campus
Narragansett, RI 02882

Working Collection
Texas A&M University
Dept. of Oceanography
College Station, TX 77843

Fisheries-Oceanography Library
151 Oceanography Teaching Bldg.
University of Washington
Seattle, WA 98195

Library
R.S.M.A.S.
University of Miami
4600 Rickenbacker Causeway
Miami, FL 33149

Maury Oceanographic Library
Naval Oceanographic Office
Building 1003 South
1002 Balch Blvd.
Stennis Space Center, MS, 39522-5001

Library
Institute of Ocean Sciences
P.O. Box 6000
Sidney, B.C. V8L 4B2
CANADA

National Oceanographic Library
Southampton Oceanography Centre
European Way
Southampton SO14 3ZH
UK

The Librarian
CSIRO Marine Laboratories
G.P.O. Box 1538
Hobart, Tasmania
AUSTRALIA 7001

Library
Proudman Oceanographic Laboratory
Bidston Observatory
Birkenhead
Merseyside L43 7 RA
UNITED KINGDOM

IFREMER
Centre de Brest
Service Documentation - Publications
BP 70 29280 PLOUZANE
FRANCE

REPORT DOCUMENTATION PAGE	1. REPORT NO. WHOI-2001-04	2. UOP 2001-01	3. Recipient's Accession No.
4. Title and Subtitle Long-Term Evolution and Coupling of the Boundary Layers in the Stratus Deck Regions of the Eastern Pacific (STRATUS)		5. Report Date June 2001	
7. Author(s) Lisanne E. Lucas, Bryan S. Way, Robert A. Weller, Paul R. Bouchard, William M. Ostrom, Albert S. Fischer, Carlos F. Moffat, Wolfgang Schneider and Melanie R. Fewings		8. Performing Organization Rept. No. WHOI-2001-04	
9. Performing Organization Name and Address Woods Hole Oceanographic Institution Woods Hole, Massachusetts 02543		10. Project/Task/Work Unit No.	
		11. Contract(C) or Grant(G) No. (C) NA96GP0429 (G)	
12. Sponsoring Organization Name and Address NOAA		13. Type of Report & Period Covered Technical Report	
		14.	
15. Supplementary Notes This report should be cited as: Woods Hole Oceanog. Inst. Tech. Rept., WHOI-2001-04.			
16. Abstract (Limit: 200 words) A surface mooring was deployed in the eastern tropical Pacific west of northern Chile from the R/V Melville as part of the Eastern Pacific Investigation of Climate (EPIC). EPIC is a CLIVAR study with the goal of investigating links between sea surface temperature variability in the eastern tropical Pacific and climate over the American continents. Important to that goal is an understanding of the role of clouds in the eastern Pacific in modulating atmosphere-ocean coupling. The mooring was deployed near 20°S 85°W, at a location near the western edge of the stratocumulus cloud deck found west of Peru and Chile. This deployment started a three-year occupation of that site by a WHOI surface mooring in order to collect accurate time series of surface forcing and upper ocean variability. The surface mooring was deployed by the Upper Ocean Processes Group of the Woods Hole Oceanographic Institution (WHOI). In collaboration with investigators from the University of Concepcion, Concepcion, Chile, an XBT section was also made on the way out to the mooring site from Arica, Chile, and an XBT and CTD section was made on the way into Arica. The buoy was equipped with meteorological instrumentation, including two Improved METeorological (IMET) systems. The mooring also carried Vector Measuring Current Meters, single-point temperature recorders, and conductivity and temperature recorders located in the upper meters of the mooring line. In addition to the instrumentation noted above, a variety of other instruments, including an acoustic current meter, an acoustic doppler current profiler, a bio-optical instrument package, and an acoustic rain gauge, were deployed. This report describes, in a general manner, the work that took place and the data collected during the Cook 2 cruise aboard the R/V Melville. The surface mooring deployed during this cruise will be recovered and re-deployed after approximately 12 months and again after 24 months, with a final recovery planned for 36 months after the first setting. Details of the mooring design and preliminary data from the XBT and CTD sections are included.			
17. Document Analysis a. Descriptors Stratocumulus clouds Air-sea interaction Moored data b. Identifiers/Open-Ended Terms c. COSATI Field/Group			
18. Availability Statement Approved for public release; distribution unlimited.		19. Security Class (This Report) UNCLASSIFIED	21. No. of Pages 106
		20. Security Class (This Page)	22. Price