

Edith Cowan University
Research Online

ECU Publications 2012

1-1-2012

Low-Cost Educational Optical Coherence Tomography System for Thickness Measurements Tomography System for Thickness Measurements

Joshua Barr

Paul V. Jansz

Edith Cowan University, pjansz@our.ecu.edu.au

Steven Hinckley

Edith Cowan University, s.hinckley@ecu.edu.au

Graham WILD

Follow this and additional works at: <https://ro.ecu.edu.au/ecuworks2012>

 Part of the [Engineering Commons](#)

Barr, J. A., Jansz, P. V., Hinckley, S. , & WILD, G. (2012). Low-Cost Educational Optical Coherence Tomography System for Thickness MeasurementsTomography System for Thickness Measurements. Proceedings of 20th Australian Institute of Physics Congress. (pp. 1-4). Sydney, Australia. Engineers Australia. Conference website available [here](#).

This Conference Proceeding is posted at Research Online.
<https://ro.ecu.edu.au/ecuworks2012/157>

Low-Cost Educational Optical Coherence Tomography System for Thickness Measurements

Joshua Barr¹, Paul Jansz¹, Steven Hinckley¹, and Graham Wild²

¹Centre for Communications Engineering Research, Edith Cowan University, Joondalup WA 6027, Australia.

²School of Aerospace, Mechanical, and Manufacturing Engineering, RMIT University, Melbourne VIC 3000, Australia.

Abstract Summary

We have developed an inexpensive rudimentary low coherence interferometer that can be used to measure sample thickness in the micron to mm range, and for exploring educational aspects of interferometry and optical coherence tomography.

Keywords- Optical coherence tomography (OCT), thickness measurement, optical metrology.

I. INTRODUCTION

Since the invention of optical coherence tomography (OCT) in 1991 [1], research has mainly focused on biomedical imaging applications of this technology [2]. More recently low coherence interferometry (LCI) has been applied to the measurement of the thickness of opaque reflective material including [3], automated contact lens metrology [4], art [5] and archeology conservation [6] scanning paper for thickness measurements [7] and quality control of multilayered printed circuit boards [8]. However, there are no educational demonstrations of this phenomena available, and commercially available systems are usually very expensive (normally tens of thousands of dollars), making them unattainable for most educational applications. Hence, there is an urgent need to develop an affordable and simple demonstration system that can be used for education of future users of low coherence interferometry (including OCT) and its application to, for example, thickness measurement.

Recently, a theoretical model of OCT has been developed from first principles [9] that allows users to simulate the performance of different aspects of OCT for specified sample structures, including the effect of different sources [9], and the behaviour of different optical delay lines [10]. This model will be used in conjunction with the proposed LCI measurement setup, to study reflection interferometry phenomena.

The objectives of this work are to develop a low-cost LCI-OCT Michelson interferometer-based setup using inexpensive optical components, that can be applied to (i) measuring the thickness of samples by reflectance interferometry, (ii) comparing theoretical modeling of this technique with experimental results, and (iii) providing simple demonstrations of the operation and performance of low coherence interferometric systems for educational purposes.

II. BACKGROUND

A. LCI-OCT Theory

In LCI and OCT, a low coherent light source generates a reflection intensity map of a material's 2D (B-Scan) or 3D cross section. Penetration depth depends on material type, increasing with wavelength and optical power and is typically 1 to 5 mm *in vivo*, increasing with longer wavelength and optical power [9]. Fig. 1 shows a Michelson OCT operation.

The axial resolution depends on the light source's spectral shape and is the coherence length (L_C) of the source spectrum divided by the average tissue refractive index, according to,

$$L_C = \frac{\ln 4 \cdot \lambda_0^2}{\pi \cdot \Delta\lambda}, \quad (1)$$

where, λ_0 is the source central wavelength, and $\Delta\lambda$ is the spectral Full Width at Half Maximum (FWHM) of the source's power spectrum. The Superluminescent diode (SLD) light source used in this research has λ_0 at 1559.6nm, with $\Delta\lambda$ equal to 39.6nm, resulting, from (1), in a L_C of 27.1 μ m.

B. OCT Simulation Model

The Matlab model [9] is based on a Michelson interferometer optical configuration (Fig. 1). It is capable of digitizing the real SLD spectrum which is used by the model to produce an interferogram of the virtual sample. The light source, optical delay line (ODL) and sample characteristics, are defined in a Microsoft Excel spreadsheet, used by the model for the OCT simulation. The model corrects for refractive index effects.

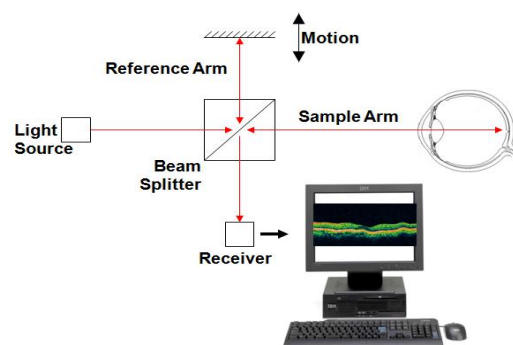

Figure 1. Fundamental time domain OCT operation, showing a Michelson interferometer-based system [9].

III. METHOD

A. Interferometer Setup

The interferometer setup is shown in Fig. 2. The basic configuration is as a Michelson interferometer, using a wide bandwidth light source and a time domain optical delay line. The samples under study were held at a constant position, relative to the interferometer arms. The optical delay line (the reference arm of the OCT system) consisted of a moving mirror, the position of which was varied using a moving stage controlled by a Thorlabs controller cube (TDC001) connected and controlled via universal serial bus (USB) from a PC. The light intensity was monitored by measuring the short-circuit photocurrent generated by the photodiode (JD-R-108331 Germanium PD 30.85A/W) using an Agilent 34401A digital multimeter (DMM), as the ODL reflector was translated at a constant velocity either side of the samples position. The coupler used was a 1550nm 50/50 coupler with each arm measuring 50 cm long alongside a Denselight DL-BZ1-CS5254A 1550nm SLD light source. The DMM readings were logged by a PC connected by a serial interface. The PC also controlled and tracked the motor used in the ODL down to micrometer precision. Software was written for the DMM in C, using Pelles C as the integrated development environment (IDE), to read measurements from the DMM at a specified interval for the time required to obtain 3000 measurements.

The samples examined were a Thorlabs precision adjustable mirror (a small glass layer with a highly polished aluminum backing), and a 3 cm × 3 cm × 2 mm sample of fused silica glass.

B. Simulations

The single mirror simulation required defining one reflective interface with a refractive index high enough so the reflection was virtually 100%. In the dual interface glass sample simulation, the glass layer was defined as 2 mm thick with the refractive index of 1.4439 [11] for fused silica glass at 1560 nm. The interface distance in both cases was not the optical distance of the experimental samples, resulting in a difference of peak positions in simulated and experimental interferograms.

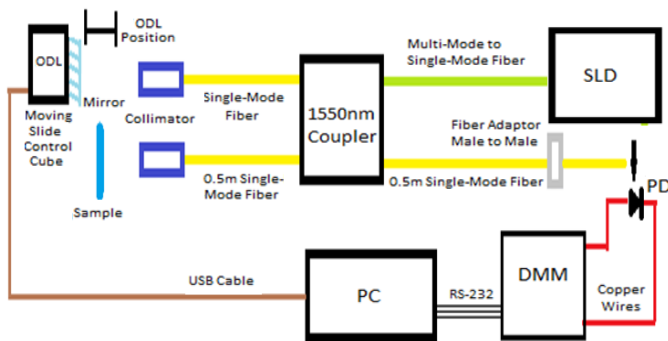

Figure 2. Experimental 1D Scanning Michelson time domain LCI.

C. System Cost

One of the major objectives of this experiment was to develop an LCI-OCT measurement setup that is low-cost, by using inexpensive optical components and simple experimental procedures. The components used to develop this system, together with associated costs were: SLD (\$2,500), 50:50 coupler (\$200), photodetector (\$100), multimeter (\$1,500), translating stage (\$300), optical driver (\$200), consumables including optical mounts and optical fibres (\$200). The total cost was about \$5,000, of which the major costs were the SLD and Agilent multimeter (\$4,000), with the remainder of the essential components being relatively inexpensive. Expenses on other components such as the PC were not included as most students would have access to one either personally or in a normal laboratory environment.

In some cases, equipment used in this experiment had a greater cost that would be ideal for a low-cost setup. For example, the multimeter cost is high, but the chosen model can be replaced by any model multimeter that can measure microampere currents and is able to be PC interfaced. The highest cost item was the SLD, which is the preferred light source for OCT. It may be possible to replace this with a lower cost high intensity IR LED in future work. In this paper, we have attempted to generate the experimental results as simply as possible. In future work, we will attempt to replace the more expensive component with lower cost alternatives.

IV. RESULTS

This section is arranged for comparisons, i.e. so that the difference between source spectrum and the ideal Gaussian spectrum can be appreciated as well as for comparison between simulation and experimental interferogram A-scans.

A. SLD Spectrum

Fig. 3 shows the superluminescent LED spectrum. The measurements indicate a peak emission wavelength of 1559.6nm with a bandwidth of 39.6nm, and a coherence length of 27.1 μ m.

B. Single Interface Mirror Sample.

Fig. 4 and 5 compare the simulated A-scan (Fig. 4) with the experimental A-Scans (Fig. 5) of the mirror sample.

Similar constructive interference is evident at the sample mirror position for both simulated (Fig. 4) and experimental (Fig. 5) interferograms.

C. Dual Interface Fused Silica Glass Sample.

Here the simulated A-scan (Fig. 6) is compared with the experimental A-Scans (Fig. 7) of the glass sample.

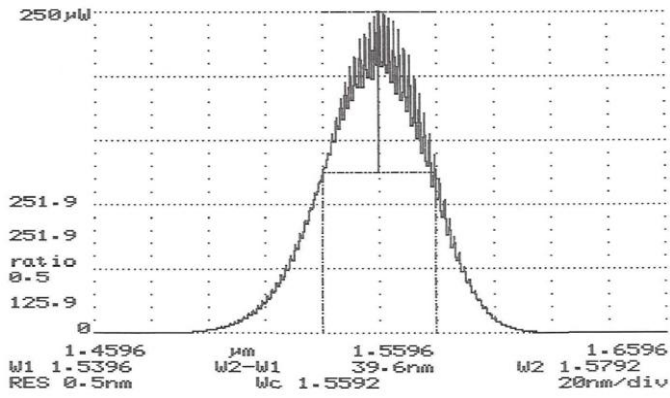

Figure 3. SLD spectrum showing $\Delta\lambda = 39.6\text{nm}$ and $\lambda_0 = 1559.6\text{ nm}$ resulting in a $L_C = 27.1\text{ }\mu\text{m}$ from (1).

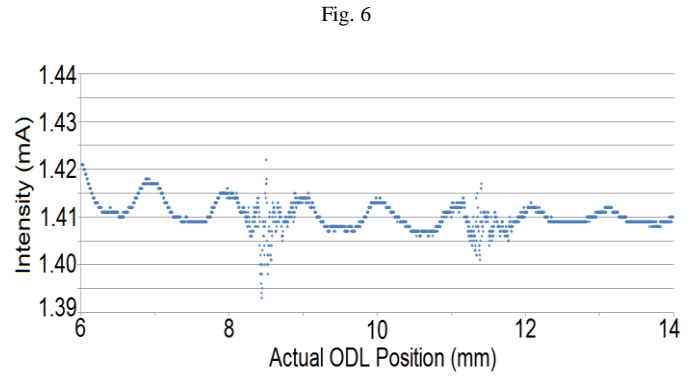

Figure 7. Measured interferometer light intensity for a dual interface glass sample using a 1560 nm SLD with Michelson Interferometer configuration, for a reference arm scan range of 9.5 mm.

V. DISCUSSION

The system has demonstrated a significant degree of accuracy and precision, with only 1% variation in repeated measurements and 1% variation from the exact position value. This was demonstrated for multiple scans under identical conditions in terms of the intensity values and the position of the interferometry peaks (corresponding to the front and back surfaces of the glass sample). This effectively demonstrates the correct operation of an OCT device, reinforcing the user's understanding of LCI. The distinct peaks and dips in each interferogram clearly indicate changes in the interference of the two reflected light beams.

Fig. 5A and 5B demonstrate an axial scan of the LCI, by using one mirror as the ODL and the other mirror as a sample mirror. This confirmed that the axial-scan of the apparatus matched the simulated results. However, the experimental results (Fig. 5A, 5B) do indicate a significantly broader full-width-at-half-maximum (FWHM) interferogram peak, compared to the simulation results (Fig. 4) for the same experimental parameters. This could be attributed to a number of factors. Firstly, the beam reference reflection may not be consistent due to the reflecting surfaces having minor irregularities. Secondly, intensity changes in the output light from the SLD can cause peak broadening. Thirdly, peak broadening can be caused by uncontrolled vibrations, either to the sample or reference mirror at the time of recording. Although these effects result in degradation of the observed spectra, they allow users to understand the causes of non-ideal phenomena and their affect on observed interferograms.

Fig. 7 shows how the LCI axial imager is able to capture and display the position of both reflected peaks of the sample. Each peak identifies the air to glass transition point of the sample at its front and back surface. The positions of the two peaks (Fig. 7) give the recorded ODL travel between peaks as $2.93 \pm 0.04\text{mm}$. The actual thickness of the glass sample is $2.03 \pm 0.03\text{mm}$, after correction for the slowing of the speed of light through the glass. As the light enters the glass, the light slows, making the ODL travel distance longer than the actual sample thickness, by a proportion of the refractive

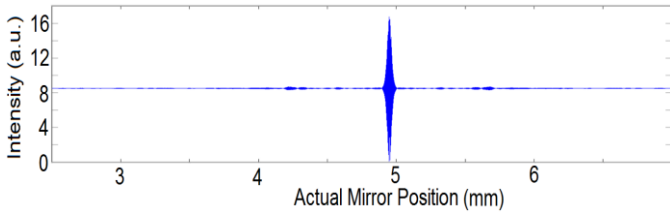

Figure 4. Simulated interferogram of perfectly reflecting virtual mirror in a TD OCT optical circuit using a digitised spectrum of the experimental SLD. Constructive interference is evident at the sample mirror position.

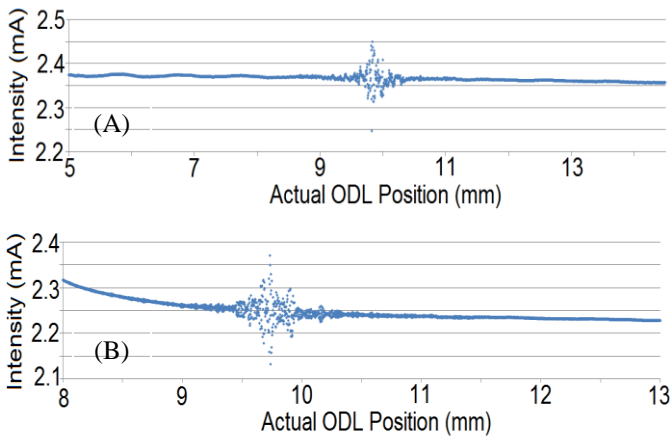

Figure 5. Measured interferometer light intensity for a mirrored sample using a 1560 nm SLD with Michelson Interferometer configuration, for a reference arm scan range of (A) 9.5 mm and (B) 5 mm.

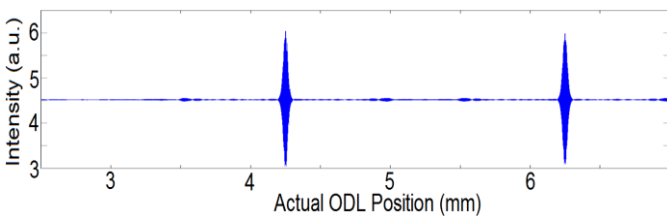

Figure 6. Simulated interferogram of 2 mm thick 1.44 refractive index virtual glass sample in a TD OCT optical circuit using a digitised spectrum of the experimental SLD. Constructive interference is evident at the sample's two interfaces, noticeable 2 mm apart.

index, 1.4439. The caliper measured thickness of the glass sample, was 2.01 ± 0.01 mm demonstrating significant accuracy with a percentage error of only 1%. The simulation accounts for the effect of refractive index and matches the recorded data, showing two peaks, 2mm apart (Fig. 6).

The experiment shows an axial resolution of about 75.6 ± 15 microns (Fig. 5A) given by an approximation of the FWHM of the recorded peak. A 1560nm Gaussian spectrum, with a FWHM bandwidth of 40nm, has a coherence length of about 27 microns under ideal conditions using (1), similar to Fig. 4.

The results indicate that a rudimentary optical setup, as presented in this paper, can provide reasonably accurate OCT data for photonics education or laboratory use at a reasonable cost. The experimental findings of this work significantly support the results of the seminal OCT paper [1], as well as recent work using OCT to scan a layered tape structure [12]. The results are comparable with respect to peak locations and intensity change due to reflection between layers. However, there is an errant sine wave in the results (Fig. 7) that is due to the motion of the ODL, as its screw mechanism changes in speed as the ODL runs, and creates the wave due to the change in the overall Doppler Effect of the mirror arm.

The discrete almost quantized nature of the experimental data is due to the loss of the last 2 digits on the DMM display, due to rounding by the DMM caused by interfacing issues. An improvement to the experimental procedure would be to amplify the signal from the photodiode (decrease in cost but possible increase in error), or obtain a more programmable DMM (increase in cost), or modify the data acquisition software to allow the computer to collect and record the last 2 digits of data eliminating the problem (no extra cost). Though the sampling rate could exceed 632 readings/mm (Fig. 5B), unfortunately, the sampling rate of 316 readings/mm (Fig. 5A, 7) was too small to capture each individual peak in the interference envelope. The solution for these problems would be an excellent project for an undergraduate student, allowing participants to obtain a better understanding of the intensity change occurring as the mirror moves, develop instrumentation skills in designing appropriate signal processing circuits (e.g. a current-to-voltage converter and amplifier), and demonstrate how outside noise affects the experiment and the data collected.

Future work will include adaption of the current equipment for more relevant industrial purposes, mentioned previously [3-8]. Future development of the system will aim to lower the cost of each component without sacrificing accuracy and precision as well as improving the sampling system. Improvements to the signal processing and optical circuitry will enable the study of multilayered samples, including

coverslip stacks, and biological phantoms. Other improvements may later also involve custom made sampling circuitry.

VI. CONCLUSION

Education as a medium for this technology allows for further development of low cost systems for industrial and commercial use. As the performed tests conducted showed the constructed device could not only identify the position with minimal error but also did it at a reasonably low cost (excluding the measuring equipment). In future further development of cheap systems like this one will allow for the costs associated with its development to decrease as some of the issues raised in the discussion are solved.

REFERENCES.

- [1] D. Huang, E. A. Swanson, C. P. Lin, J. S. Schuman, W. G. Stinson, W. Chang, and J. G. Fujimoto, "Optical coherence tomography," *Science*, vol. 254, pp. 1178-1181, 1991.
- [2] W. Drexler, J.G. Fugimoto (edt), "Part IV : Optical Coherence Tomography Applications", in *Optical Coherence Tomography: Technology and Applications*, Berlin, Heidelberg : Springer-Verlag, pp. 888 - 1326 (2008).
- [3] M. Leitner, "Looking inside materials with optical coherence tomography", at http://www.recendt.at/517_ENG_HTML.php , accessed 13th January, (2012).
- [4] B. R. Davidson, J. F. Barton, "Application of optical coherence tomography to automated contact lens metrology", *Journal of Biomedical Optics*, vol. 15, no. 1, 016009-1-9, 2010.
- [5] H. Liang, M. Cid, R. Cucu, G. Dobre, A. Podoleanu, J. Pedro, and D. Saunders, "En-face optical coherence tomography - a novel application of non-invasive imaging to art conservation", *Optics Express*, Vol. 13, no. 16, pp. 6133-44, 2005.
- [6] H. Liang, B. Peric, M. Hughes, A. Podoleanu, M. Spring, and D. Saunders, "Optical coherence tomography for art conservation and archaeology" *Proc. SPIE Vol. 6618*, 661805, 2007.
- [7] E. Alarousu, "Low Coherence Interferometry And Optical Coherence Tomography In Paper Measurements," *OULU University Press* pp. 256, 2006.
- [8] M. W. Lindner, P. Andretzki, F. Kiesewetter, G. Häusler, "Handbook of Optical Coherence Tomography", ed G J Tearney and B E Bouma, New York: Marcel Dekker, pp 335-57, 2002.
- [9] P. Jansz, S. Richardson, G. Wild, and S. Hinckley, "Modelling of low coherence interferometry using broadband multi-Gaussian light sources", *Photonic Sensors*, vol. 2, no. 3, pp. 247-258, Sept. 2012.
- [10] P. Jansz, G. Wild, S. Richardson, and S. Hinckley, "Simulation of an optical delay lines for optical coherence tomography", *Proceedings of IQEC/CLEO Pacific Rim*, Australian Optical Society, Sydney pp. 1400 - 2, 2011.
- [11] http://refractiveindex.info/?group=GLASSES&material=F_SILICA accessed 17th July 2012.
- [12] V. D. Nguyen, J. Kalkman, T. G. van Leeuwen, K. Worhoff, R. M. de Ridder, and M. Pollnau, "Towards a miniaturized optical coherence tomography system," *Proc. Of Conference on Lasers and Electro-optics (CLEO)*, pp. 1-2, 2011.