

Edith Cowan University
Research Online

ECU Publications Pre. 2011

2008

An Intensiometric Detection System for Fibre Bragg Grating Sensors

Graham Wild
Edith Cowan University

Steven Hinckley
Edith Cowan University

Follow this and additional works at: <https://ro.ecu.edu.au/ecuworks>

 Part of the [Engineering Commons](#)

[10.1109/OECCACOFT.2008.4610361](https://ro.ecu.edu.au/ecuworks/820)

This is an Author's Accepted Manuscript of: Wild, G. , & Hinckley, S. (2008). An Intensiometric Detection System for Fibre Bragg Grating Sensors. Proceedings of of OECC/ACOFT 2008. (pp. 2). Sydney, Australia. IEEE. Available [here](#) © 2008 IEEE. Personal use of this material is permitted. Permission from IEEE must be obtained for all other uses, in any current or future media, including reprinting/republishing this material for advertising or promotional purposes, creating new collective works, for resale or redistribution to servers or lists, or reuse of any copyrighted component of this work in other works.

This Conference Proceeding is posted at Research Online.
<https://ro.ecu.edu.au/ecuworks/820>

An Intensiometric Detection System for Fibre Bragg Grating Sensors

Graham Wild and Steven Hinckley

Physics Research Group, Edith Cowan University, Joondalup, WA 6027, Australia

Phone: +61863045129, Fax: +61863045811, Email: G.Wild@ecu.edu.au

Abstract - We present an Intensiometric Detection System for Fibre Bragg Grating sensors. The system is designed to directly detect intensity modulated signals, or to convert spectrally modulated signals into intensity modulated signals.

Introduction

Fibre Bragg Grating (FBG) sensing research tends to focus on the use of FBGs as spectral transduction elements. The absolute nature of the spectral encoding of the measurand makes FBG sensors immune to optical power fluctuations. It also enables large numbers of FBGs to be multiplexed along lengths of optical fibre. The spectral property of FBGs means they can be easily multiplexed in Wavelength Division Multiplexing (WDM) [1]. These systems require spectral decoding of the sensor signals, which can be slow and expensive. Conversely, FBGs can be used as intensity based sensors, using edge filter detection or power detection [2]. Here, the intensity information from the FBG can easily be correlated to a change in the measurand. Problems, such as input optical power fluctuations, are reintroduced into the system. However, the advantages of edge filter detection, specifically the simplicity of detection, greatly outweigh the corresponding disadvantages.

In this paper, we present an Intensiometric Detection System (IDS) capable of detecting intensity modulated signals from optical fibre sensors, specifically FBGs. We also show a simple modification to the system which will enable spectrally encoded signals to be converted to intensity modulated signals for detection. The system would be capable of receiving signals from multiplexed FBGs, using WDM or Time Division Multiplexing (TDM).

Electronic System Design

The IDS is an extension of initial work done on a

Transmit Reflect Detection System (TRDS) [3]. The TRDS differentially amplified the transmitted and reflected signals from a single edge filter detected FBG sensor. The result of the TRDS was improved sensitivity and efficiency, specifically with high frequency dynamic signals, such as ultrasound [4].

The IDS design includes 2 PIN receivers (Fujitsu FRM3Z231KT). The preamp supply and PIN bias is provided by a +/- 5V supply. The power supply is internal, which uses a centre tapped 12.6V transformer to step down mains voltage. This is then half wave rectified, filtered, and regulated. For the IDS, the output of the two receivers is differentially amplified using a high speed differential amplifier (AD830ANZ). The differential output is then digitised via an ADC (AD7827BNZ). An eight bit ADC was chosen for speed and to ensure the computer interface for the initial system was as simple as possible. The computer interface is an eight channel USB interface (DLP-IO8-G), based on a USB to serial converter (FT232R), and a microcontroller (PIC16F688). The electronic circuit is shown in Figure 1.

Two possible future modifications have been considered for the electronic system design. These are increasing the data rate, and increasing the resolution. There is a trade off between these two aspects. To increase the speed, a USB to parallel interface (FT245R) could be utilised, which would allow all eight bits to be transferred at the maximum rate of the interface (USB245M) of 1MBps. To increase the resolution of the system a 16 bit, or better, ADC could be used. To ensure the system is as fast as possible the full serial nature of the ADC could be utilised with a direct connection to the USB to serial converter (FT232R).

To make the IDS compatible with the configurations considered below, programmable gain amplifiers would need to be added. These would go after the preamp of the receiver, but before the differential amplifier.

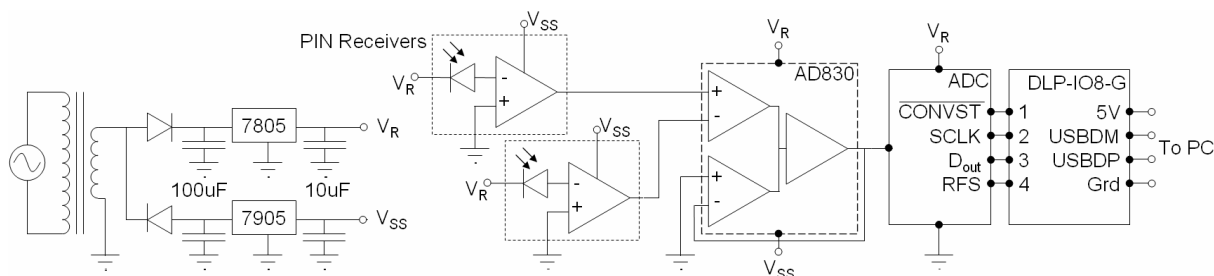

Fig. 1. Circuit diagram of the IDS. The PIN receivers give a negative offset due to amplifier bias. The offset is removed by the difference amplifier, giving a positive or negative signal. The ADC has an internal 2.5V reference to give only positive bits.

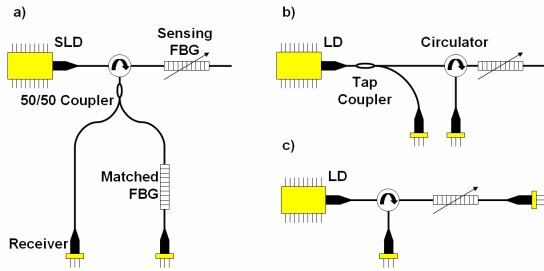

Fig. 2. Optical circuits for intensity modulated FBG interrogation. (a) Matched FBG edge filter detection, (b) power detection, and (c) transmit-reflect power detection.

Optical System Design

To detect intensity modulated signals from FBG sensors, no additional optics is required for the IDS. This includes both edge filter detection, and power detection systems. Figure 2 shows the use of the two receivers in the IDS for (a) power detection, (b) edge filter detection, and (c) transmit-reflect detection.

For quasi-static spectrally encoded signals to be converted to intensity modulated signals, a Tunable Laser (TL) is used as the source. This would require no additional optics for the IDS. The peak reflected intensity could be directly correlated to the wavelength of the laser via a computer interface to both the TL and the IDS. This method could be used with a WDM system. However, this method could not be used for high speed dynamic signals. Figure 2 (b) represents the geometry of the optical system, however, a TL would be

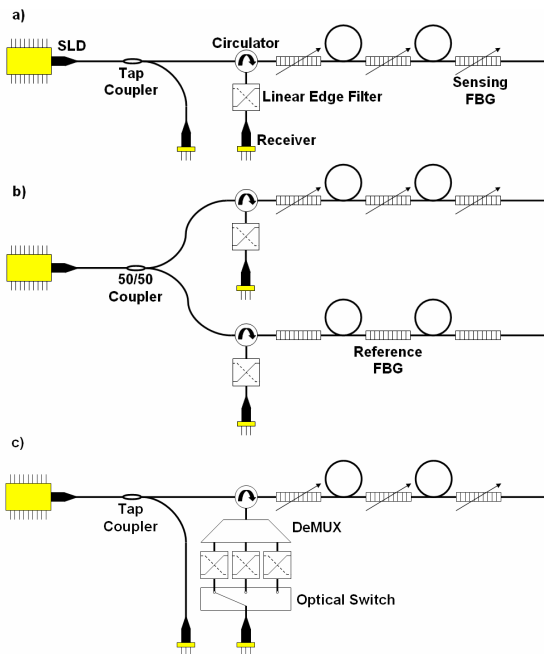

Fig. 3. Optical circuits for multiplexed FBG sensors interrogation using the IDS with linear edge filters. TDM using (a) a tap coupler, or (b) a reference fibre. (c) WDM using a DeMUX and an optical switch.

used in place of the laser diode.

Traditional FBG sensing systems utilise broadband light sources, such as SuperLuminescent Diodes (SLD). To convert the spectrally encoded signals from these sensors into intensity modulated signals for detection with the PIN receivers, a linear edge filter is used. Linear edge filters have previously been used to convert dynamic strain signals from FBGs [5-6]. To resolve the input power fluctuation issue, a tap coupler is used to give a reference intensity signal, show in Figure 3 (a). A more robust system could employ a reference fibre length, with an identical configuration to the sensing fibre length, shown in Figure 3 (b).

For TDM FBG sensors, the source is pulsed. The time-dependent intensity information is then sampled at appropriate points to recover the sensor information. For WDM FBG sensors, a demultiplexer is used, with a linear filter on each channel. To utilise a single receiver system, an optical switch is used to select the appropriate channel. The WDM interrogation system is shown in Figure 3 (c).

System Test

To ensure the constructed IDS module was working effectively, a simple test experiment was performed. Due to the generation of balance signals for the differential amplifier, a transmit-reflect detection system was used as the input to the IDS. The sensing system was used to monitor the longitudinal strain applied to a steel sample, previously done with the TRDS [3]. The FBG was bonded to the sample using cyanoacrylate. A stress strain apparatus was used to apply a tensile force to the test sample, giving the applied stress and the resultant strain. The signal from the FBG sensor was interrogated by the IDS. Due to the quasi-static nature of the measurand, simple communication was established with the module via the hypertext terminal. For this, the onboard ADC of the module was used.

The IDS detection system preformed as designed. More thorough testing is to be undertaken. The focus will be on the development of software to ensure the system can be used to effectively detect dynamic signals.

Conclusions

In conclusion, we have presented an Intensiometric Detection System for Fibre Bragg Grating sensors. The IDS developed can be used as a detection system for intensity based FBG sensors. The proposed IDS can be used to decode spectrally modulated FBG sensor signals

References

1. A.D. Kersey, LEOS '94 2 (1994) p. 153.
2. B. Lee and Y. Jeong, in "Fiber Optic Sensors" (Marcel Dekker, New York, 2002), p. 295.
3. G. Wild, S. Hinckley and P.V. Jansz, Proc SPIE 6801 (2007) p. 68010N.
4. G. Wild and S. Hinckley, ICST (2007) p.546.
5. C. Ambrosino et al, Proc SPIE 6619 (2007) p. 661940-1.
6. C. Ambrosino et al, ICST (2007) p. 410.