

Edith Cowan University
Research Online

ECU Publications Pre. 2011

1-1-2010

Wireless Acoustic Communications and Power Supply for In-vivo Biomedical Devices

Graham Wild
Edith Cowan University

Steven Hinckley
Edith Cowan University

Follow this and additional works at: <https://ro.ecu.edu.au/ecuworks>

 Part of the [Engineering Commons](#)

[10.1109/ULTSYM.2010.5936017](https://ro.ecu.edu.au/ecuworks/6470)

This is an Author's Accepted Manuscript of: Wild, G., & Hinckley, S. (2010). Wireless Acoustic Communications and Power Supply for In-vivo Biomedical Devices. Proceedings of IEEE International Ultrasonics Symposium. (pp. 4p.). San Diego, California, USA. Institute of Electrical and Electronic Engineers. Available [here](#)

© 2010 IEEE. Personal use of this material is permitted. Permission from IEEE must be obtained for all other uses, in any current or future media, including reprinting/republishing this material for advertising or promotional purposes, creating new collective works, for resale or redistribution to servers or lists, or reuse of any copyrighted component of this work in other works.

This Conference Proceeding is posted at Research Online.
<https://ro.ecu.edu.au/ecuworks/6470>

Wireless Acoustic Communications and Power Supply for *In Vivo* Biomedical Devices

G. Wild and S. Hinckley
School of Engineering, Edith Cowan University
270 Joondalup Drive
Joondalup, WA 6027 Australia

Abstract—Pacemakers are common biomedical devices used in the treatment of specific cardiovascular problems. Current research in biomedical engineering is investigating the use of so called brain pacemakers to regulate conditions such as Parkinson’s and other neurological conditions. In this paper, we demonstrate the principle of acoustic communications and power harvesting, *in vivo*. The signals are intended to be used for fixed *in vivo* biomedical devices, such as pacemakers, were wired and wireless RF communications cannot be used. Results show the performance of the communications channel. The frequency response, transfer function and transient response (at resonance) of the communications channel were measured. Successful communication was achieved through the communications channel using phase shift keying. A data rate of 40kbps could be achieved. Preliminary results harvesting these acoustic signals to recharge the *in vivo* biomedical devices give a maximum AC power of 1.12mW.

I. INTRODUCTION

Neurological pacemakers are currently used to regulate conditions such as Parkinson’s diseases [1]. Transient devices, such as those used in the gastrointestinal track, make use of high frequency RF, where the permittivity of the human body begins to decrease [2]. However, significant power is still required for communications. This results in local tissue heating due to the absorption of the EM radiation. This heating has side effects that limit the exposure times for safe practices [3-5]. For neural implants, where the goal is to have the product implanted for long periods of time, without complications and minimal side effects, RF communications is not currently used.

Wireless acoustic communications represents an ideal, low power method of communicating with *in vivo* biomedical devices. Acoustic communications has previously been proposed for communications in Structural Health Monitoring (SHM) systems, where autonomous robotic agents are used for inspection and repair [6-8]. Here, acoustic signals were successfully shown to be used for transmitting relatively high data rates (up to 100kbps) using piezoelectric transducers and aluminum paneling.

The added advantage of utilizing acoustic communications is the use of a piezoelectric receiver. This means that current work into piezoelectric power harvesting [9] could be utilized for supplying power to the *in vivo* biomedical devices. Here, the acoustic transmissions used for communications, can be used to transmit power.

II. THEORY

A. Communications

As with previous work [6-8], we implement Phase Shift Keying (PSK) due to the frequency response of the communications channel. The encoding of the PSK signal is achieved by switching the phase of the carrier wave by 180 degrees. Decoding the received signal is achieved with some simple mathematics, which involves;

- multiplying the received signal by a synchronous sine and cosine (called I and Q respectively),
- low pass filtering to remove the carrier, and then,
- taking the arctangent of I on Q to recover the phase of the information.

The filter used was a raised cosine filter [10]. The decoding algorithm was implemented in Matlab (The MathWorks, Inc).

B. Power Harvesting

For the power harvesting, the piezoelectric receiver is modeled as an AC current source, i_p , in parallel with a capacitor, C_p . The amplitude of the current source, I_p , is referred to as the short circuit current. The open circuit voltage, V_{OC} , can then be defined in terms of the short circuit current and capacitance [11], that is,

$$V_{OC} = \frac{I_p}{\omega C_p} \quad (1)$$

where ω is the angular frequency of the current source.

To harvest the power, the piezoelectric element needs to be connected across a load resistance. A simple RC circuit analysis gives the output voltage (V) as [9],

$$V = \frac{I_p R}{\sqrt{1 + (\omega C_p R)^2}} \quad (2)$$

where R is the size of the load resistor.

The power as a function of the resistance can then be expressed as,

$$P = \frac{V^2}{R} = \frac{I_p^2 R}{1 + (\omega C_p R)^2} \quad (3)$$

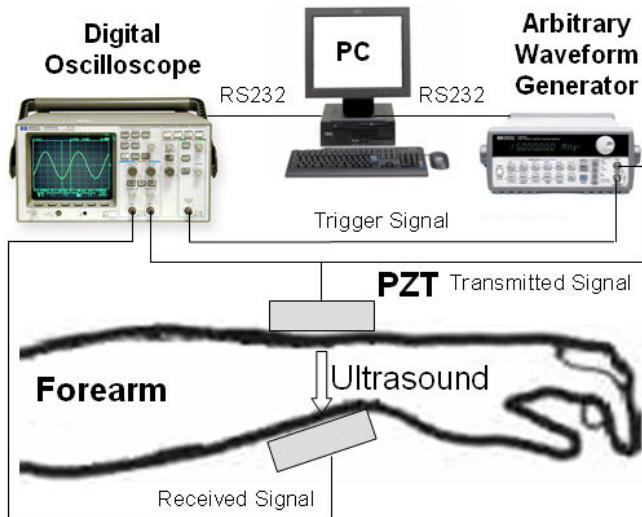

Fig. 1. Setup of the acoustic transmissions channel.

III. METHOD

A. Channel Characterization

The experimental setup of the acoustic transmissions channel is shown in Figure 1. The PZT transducers used were un-backed, and coupled to the forearm using acoustic coupling gel. The piezoelectric transducers used were Steiner and Martins SMQA PZTs. They had a thickness of 2.1mm, corresponding to a resonant frequency of 1MHz, and a radius of 10mm.

The channel was characterized in terms of,

- the transfer function,
- the frequency response, and
- the transient response.

First, the transfer function of the communications channel was measured. The function generator was set to give a continuous sine wave at the resonant frequency of the PZT transducers, 1MHz. The amplitude was then varied from 1 volt to 10 volts. Values were recorded at 1 volt increments. This process was repeated several times to give an average and statistical uncertainty.

Next, the frequency responses of the communications channel were determined. The function generator was set to give a continuous sine wave at maximum voltage, 10 Volts peak. The frequency was then varied from 10 kilohertz to 2 Megahertz. Values were recorded every 10 kilohertz.

Finally, the transient response of the communications channel was investigated, using a low rate sine wave burst at 1MHz with 100 cycles. The trailing signal is also examined to determine if it will have any adverse effects on the performance of the communications channel.

B. Communications

The communications signals were generating on an Agilent 33120A arbitrary waveform generator. The PSK signals were generated in the Waveform Editor software for the waveform generator. The signals were then flashed to the device via the

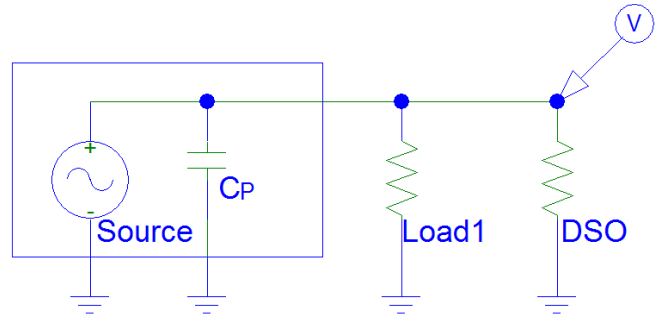

Fig. 2. The PSpice simulation circuit, with the AC current source and the source capacitor as the piezoelectric receiver in parallel with the Load and DSO.

computer interface. The waveform generated consisted of a sine wave carrier, with a data rate of 1/100 the carrier frequency (the software does not generate time so the frequency is set and varied on the generator, and hence a ratio is used). So for the carrier wave frequency of 1MHz, the data rate was 10kbps.

The communications signals were recorded on the DSO and downloaded to a PC. The signals were then demodulation using the Matlab (The MathWorks, Inc) program.

C. Power Harvesting

For the preliminary acoustic power harvesting, the AC performance was analyzed. First the capacitance of the piezoelectric element was measured using a capacitance meter. After calculating the reactance at the resonant frequency, the output of the piezoelectric receiver was applied to a variable resistor. The voltage drop across the load was then measured using a 1MΩ Digital Storage Oscilloscope (DSO). The AC circuit was also simulated in PSpice (Cadence Design Systems, Inc). The value of I_p was obtained from (1), using the measured values of C_p and V_{OC} . A parametric analysis was performed, varying the value of the load resistance in a frequency domain analysis. The load value was swept from 10Ω to the value of the DSO, 1MΩ at 10 points per decade. Figure 2 shows the circuit diagram for the power harvesting simulations. For the experiments, this simply required the load resistance to be placed between the received line and ground of Figure 1.

IV. RESULTS AND DISCUSSION

A. Channel Performance

Fig. 3 shows the transfer function of the transmissions channel. As expected, for the range of values considered, the transfer function is linear. The coefficient is quite low, too low to use a conventional AC to DC converter circuit for the power harvesting. For future work it will be necessary to address this issue. One way to do this would be to use an amplified source. However, for power transmission it would be more efficient to try and eliminate losses in the channel. The channel could be made more efficient by using transducers with their acoustic impedance matched to the transmission medium. Some randomness is noticeable in the signal, hence the uncertainty.

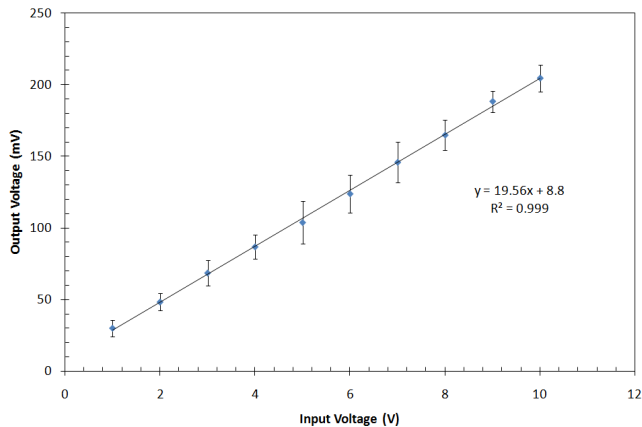

Fig. 3. Transfer function of the transmission channel.

It is worth noting that a similar uncertainty would be expected on all other results. The experiments were performed with the arm as immobile as possible. A significant variation was noticed when the arm/hand was allowed to articulate. The peak value varied from around 140mV to 280mV, a factor of 2. These fluctuations suggested that PSK would be a more robust encoding method compared to amplitude shift keying.

The frequency response of the acoustic transmission channel is shown in Fig. 4. Two peaks are shown in the data, the primary peak around 1MHz and a secondary peak around 100kHz. These correspond to the fundamental longitudinal mode and the fundamental radial mode, respectively. We can see from the frequency response that PSK would be a more robust encoding method compared to frequency shift keying. The frequency response also suggests that the bandwidth for the communications signal will be low relative to the resonant frequency. This is due to the fact that the communications bandwidth is related to the bandwidth of the resonance. To increase the achievable data rates, a broadband transducer could be utilized.

Fig. 5 shows the transient response of the transmission channel. The received tone burst is relatively compact, with a short transient period, and a small amount of signal in the tail. The rise time, which takes approximately 25 cycles at 1 megahertz, was measured as 25 microseconds. Although Fig. 4 suggests that relative to the carrier frequency, the data rate

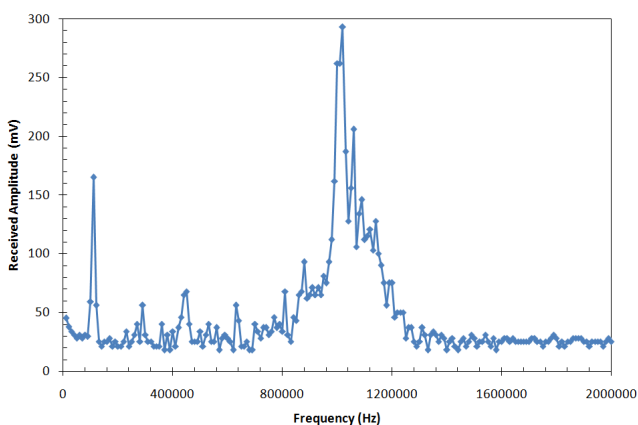

Fig. 4. Frequency response of the transmission channel.

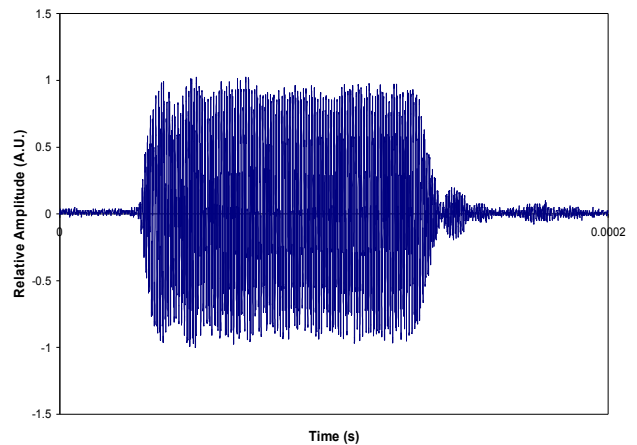

Fig. 5. Transient response of the transmission channel.

would be low, the result of the transient response suggests that sufficient data rates may be achievable, specifically if a transducer with a higher resonant frequency was to be utilized. The use of a high communications rate would reduce the effect of fluctuations due to motion of the communications medium.

B. Communications Signals

The results of the acoustic communications test are shown in Fig. 6 and 7. Fig. 6 shows the received PSK signal, which contains the data stream [1 1 0 0 1 0 1 1 1]. The decoded PSK signal is then shown in Fig. 7. The original digital information can be recovered by selecting a digital 1 as a phase less than 0 degrees, and a digital 0 as a phase greater than 0 degrees. The recovered phase information from the phase shift keying signal suggests that a relatively high data rate is possible. The phase transitions indicate that a data rate up to that of the amplitude shift signal (40 kilobits per second) could be used.

C. Power Harvesting

The capacitance of the piezoelectric receiver was measured to be 1.086nF. At the resonant frequency of 1.035MHz, this gives a reactance of 141Ω. With an open circuit voltage of 570mV, (1) gives a short circuit current of 4mA. These values were then used in the PSpice simulation of the AC circuit.

Fig. 8 shows the load current as a function of the output

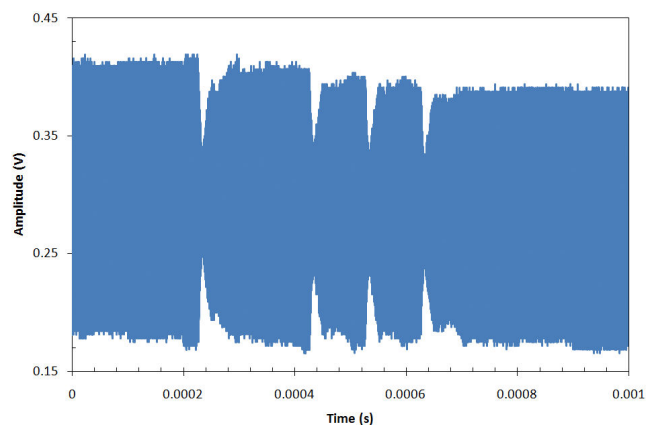

Fig. 6. The received PSK acoustic communications signal.

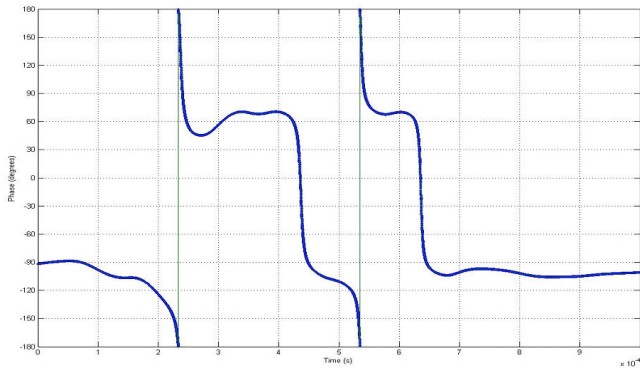

Fig. 7. Phase diagram showing the recovered phase information from the PSK signal.

voltage (IV curve), and Fig. 9 shows the power delivered to the load as a function of the output voltage (PV curves), for the experimental, theoretical and simulated results. The PV curve shows a measured peak power of 1mW, while theory and simulation give peak power values of 1.121mW and 1.125mW, respectively.

The preliminary results for the power harvesting are promising. The value of 1mW was significant compared to values expected. However, in the attempt to implement an AC to DC converter, the very high frequency appears to be limiting the ability to successfully rectify the output of the transducer. This is mainly due to the high junction capacitance of the rectifier diodes. In the conversion from AC to DC, the capacitance is an important consideration to achieve peak power output [9]. To resolve this issue, we intend to acquire transducers with a lower resonant frequency, in the kilohertz range, and quantify the performance of the power conversion as a function of frequency.

However, with the successful implementation of an AC to DC converter, the measured power levels could easily be utilized for the *in vivo* recharging of a device such as a pacemaker [12].

V. CONCLUSION

In conclusion, we have successfully used acoustic transmissions to both communicate and harvest power through a biological medium, *in vivo*. The acoustic communications show great promise for utilization in practical communications

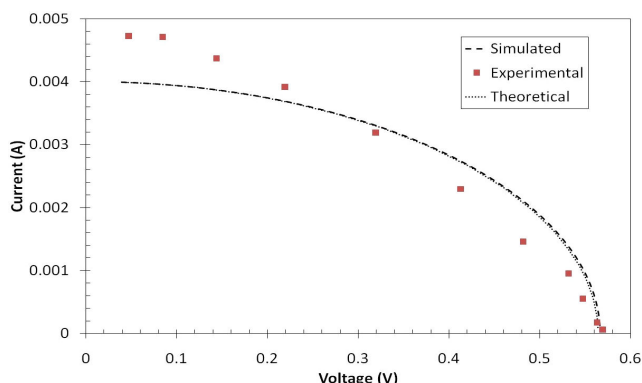

Fig. 8. Load current as a function of the voltage, I-V curve.

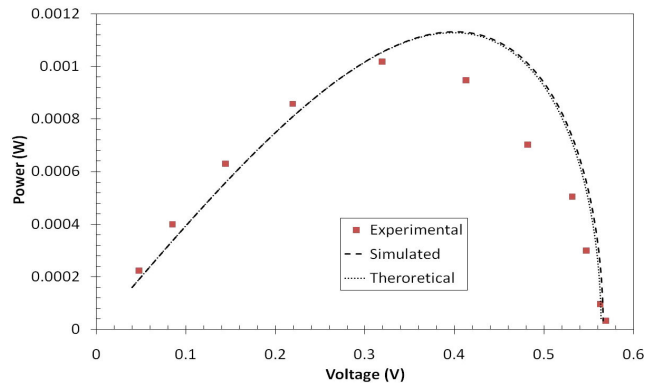

Fig. 9. Power delivered to the load as a function of the voltage, P-V curve.

with *in vivo* biomedical devices; specifically in those applications where local heating effects of wireless RF transmission is prohibitive. Even if the data rate was lowered in order to reduce the bit error rate, and increase reliability, a significant data rate could be utilized, more than is necessary for static biomedical devices. The power that can be delivered through the channel is also promising, especially for low power devices, such as pacemakers and neural implants.

REFERENCES

- [1] V. K. Varadan, "The role of nanotechnology and nano and micro-electronics in monitoring and control of Cardiovascular diseases and neurological disorders," Proc. SPIE, vol. 6528, 2007.
- [2] C. Kim, T. Lehmann and S. Nooshabadib, "An ultra-wideband transceiver for biotelemetry systems," Proc. SPIE, vol. 6798, 2007.
- [3] C. Gabriely, S. Gabriely and E. Corthout, "The dielectric properties of biological tissues: I. Literature survey," Phys. Med. Biol. vol. 41, pp. 2231–2249, 1996.
- [4] S. Gabriely, R.W. Lau and C. Gabriel, "The dielectric properties of biological tissues: II. Measurements in the frequency range 10 Hz to 20 GHz," Phys. Med. Biol. vol. 41, pp. 2251–2269, 1996.
- [5] S. Gabriely, R.W. Lau and C. Gabriel, "The dielectric properties of biological tissues: III. Parametric models for the dielectric spectrum of tissues," Phys. Med. Biol. vol. 41, pp. 2271–2293, 1996.
- [6] G. Wild and S. Hinckley, "Electro-acoustic and acousto-optic communications for robotic agents in smart structures," Proc. SPIE, vol. 6414, 2006.
- [7] G. Wild and S. Hinckley, "Wireless acoustic communications for autonomous agents in structural health monitoring sensor networks," Proc. SPIE, vol. 6798, 2007.
- [8] G. Wild and S. Hinckley, "Pspice simulation of an electro-acoustic communications channel.5442893 abstract," IEEE Trans. Ultrason., Ferroelectr., Freq. Control, vol. 57, no. 4, pp. 981-985, 2010.
- [9] G.K. Ottman, et al., "Adaptive piezoelectric energy harvesting circuit for wireless remote power supply" IEEE Trans. Power Electron. vol. 17, no. 5, pp. 669-676, 2002.
- [10] J. Proakis and M. Salehi, *Communication Systems Engineering*, New Jersey: Prentice Hall, 1994.
- [11] M. Guan and W.H. Liao, "Comparative analysis of piezoelectric power harvesting circuits for rechargeable batteries" in Proc. 2005 IEEE Int. Conf. Information Acquisition, pp. 243-246, 2005.
- [12] V.S. Mallela, V. Ilankumaran and N.S. Rao, "Trends in cardiac pacemaker batteries" Indian Pacing Electrophysiol. J., vol. 4, no. 4, pp. 201–212, 2004.