

2015

## Language Teachers' Conceptions of Intelligence and their Roles in Teacher Care and Teacher Feedback

Reza Pishghadam

*Ferdowsi University of Mashhad*, pishghadam@um.ac.ir

Elham Naji Meidani

*Ferdowsi University of Mashhad*

Gholam Hassan Khajavy

*Ferdowsi University of Mashhad*

Follow this and additional works at: <https://ro.ecu.edu.au/ajte>



Part of the [Educational Psychology Commons](#), and the [Other Teacher Education and Professional Development Commons](#)

---

### Recommended Citation

Pishghadam, R., Naji Meidani, E., & Khajavy, G. (2015). Language Teachers' Conceptions of Intelligence and their Roles in Teacher Care and Teacher Feedback. *Australian Journal of Teacher Education*, 40(1). <http://dx.doi.org/10.14221/ajte.2015v40n1.4>

This Journal Article is posted at Research Online.  
<https://ro.ecu.edu.au/ajte/vol40/iss1/4>

## Language Teachers' Conceptions of Intelligence and their Roles in Teacher Care and Teacher Feedback

Reza Pishghadam  
Elham Naji Meidani  
Gholam Hassan Khajavy  
Ferdowsi University of Mashhad, Iran

*Abstract: The purpose of this study was to find the relationships among teachers' conceptions of intelligence, teacher care, and teacher feedback in the realm of English Language Teaching (ELT). To this aim, three scales were developed to measure the aforementioned constructs. The participants consisted of 81 English as a Foreign Language (EFL) teachers and their 426 students who were learning English in private language institutes. The scales were validated by Confirmatory Factor Analysis (CFA) and the correlations among their subscales were investigated. The findings suggested that modularity, increasability, and applied ELT are associated with the nature and amount of teacher feedback and care as perceived by the students. Moreover, the results revealed that teachers' conceptions of intelligence significantly affect how they evaluate their students ( $p < .05$ ). In the end, implications were provided in the context of teaching.*

### Introduction

Ellis (2008) defines intelligence as a general set of cognitive abilities involved in performing a wide range of learning tasks. Individuals look at intelligence from their own point of view and form their own "conceptions" towards it (Faria, 1998). Conceptions consist of beliefs, attitudes, and intentions (Brown, 2008), which may significantly affect behavior (Ajzen, 2005). Teachers, as professionals who are constantly dealing with learners and their cognitive abilities, develop certain conceptions about intelligence, which could influence their behavior in the classroom. In the field of second/foreign language teaching, intelligence has been mentioned as an influential psychological construct in the learning process (Dornyei, 2005). It follows that language teachers enter the classroom with a set of conceptions about intelligence and its role in language learning, which could be manifested both verbally and non-verbally in how they treat their students.

The conceptions that teachers form in their mind about learners' intelligence may be demonstrated in the care that they provide learners with. The term 'teacher care' reflects those practices conducted by teachers in order to establish rapport and a positive relationship with their students (Rogers & Webb, 1991). Feedback, the information passed on from the teacher to the students about their performance, is another important aspect of the teacher-student communication (Mitchell & Myles, 2004). In the field of ELT, due to the huge attention

devoted to the teacher-student relationship, learner-centered classrooms, and the psychology of the language learner (see Ellis, 2008), teacher care and teacher feedback are considered as two highly significant constructs.

A few studies have examined teachers' conceptions of intelligence and their relationship with different factors, such as teachers' educational goals (Lynott & Woolfolk, 1994), teachers' biases in giving responses to students (Lee, 1996), students' self-perceptions in learning (Pretzlik, Olsson, Nabuco, & Cruz, 2003) and their field of teaching (Jonsson, Beach, Korp, & Erlandson, 2012). To the researchers' knowledge, however, no study has quantifiably examined the relationship between language teachers' conceptions of intelligence and their classroom behavior in an EFL context. In their classroom interactions, language teachers frequently evaluate, respond, and react based on how they define intelligence and the role they assign to it in language learning. Since teacher care and teacher feedback essentially embrace most of the interactions that take place between the teacher and the students, they have been selected as two principal and interrelated aspects of teacher practice in the present study, to see whether they have a significant relationship with language teachers' conceptions of intelligence. In the following sections a brief account of the background of the study is provided.

## **Intelligence in Education**

The concept of intelligence has passed an evolutionary trend. It first began as a one-dimensional concept or *g* factor (Spearman, 1904). From this point of view, intelligence (*g*) was described as "the ability to deal with cognitive complexity" (Gottfredson, 1998, p. 24). In 1993, Gardner redefined intelligence as "a biopsychological potential to process information that can be activated in a cultural setting to solve problems or create products that are of value in a culture" (p.33). Therefore, the term 'Multiple Intelligences' (MI) was introduced for the first time. Gardner's view was in contrast with the former view, which stated that intelligence is based on a unitary or 'general' ability for problem solving (Teele, 2000). Gardner claimed that the brain has different and equally important types of intelligence, and emphasized on discrete cognitive abilities, closely related to the concept of modularity (Jarvis, 2005). Modularity is about the degree to which cognitive domains are separable, that is whether they function independently of one another (see Elsabbagh & Karmiloff-Smith, 2006). Similar to Gardner, Robert Sternberg presented a revolutionary definition of the word "intelligence". In his triarchic view of intelligence, Sternberg (1985) proposed three metacomponents for the construct: analytical, creative, and practical. Analytic intelligence or componential ability relates to analyzing, evaluating, judging, comparing, and contrasting; creative intelligence or experiential ability concerns engaging in creative thinking and coping with novelty; and practical intelligence or contextual ability involves dealing with problems and issues in daily life. Sternberg (2002) called his theory the "theory of successful intelligence". Another important aspect of intelligence is its increasability (Jarvis, 2005). There are two theories in this regard (Bandura & Dweck, 1981): incremental theory which sees intelligence as malleable, changeable, and able to be increased; and entity theory which sees intelligence as something inborn, fixed, and unchangeable. Thus, the incremental view is defined as the belief that individuals can control their intelligence and increase it by studying and learning, while the entity theory believes that intelligence is genetic and humans are born with a predetermined level of it.

Within the domain of general education, studies have revealed that intelligence can be a strong predictor of learning (Chamorro-Premuzic, 2007; Primi, Ferrao, & Almeida, 2010). In fact, the existence of a positive correlation between IQ and school performance is one of the most common contributions confirmed by research in educational psychology (Faria, 1998). In language education, in particular, there are two major views about the relation between intelligence and language learning. One view claims that language learning ability is the same as other skills (non-modularity), whereas the other view states that there is a special talent for learning a new language and that language develops independent of other cognitive functions (modularity). Studies have supported the latter view by revealing that some students have a high IQ, but are weak at language learning (Ganschow & Sparks, 2001), while some are good language learners despite having a low IQ (Sparks & Atzer, 2000). By and large, modularity theory seems to be more in line with the reality of mind.

Researchers have investigated the relationship between learners' implicit theories of intelligence and their academic achievement (Braasch, Braten, Stromso, & Anmarkrud, 2014; Good, Aronson, & Inzlicht, 2003). All studies have shown that learners' beliefs in incremental theory lead to their higher performance. In contrast, belief in a limited quantity of intelligence has shown to create anxiety in learners, leading to their underachievement (Jarvis, 2005). On the whole, it has been frequently attested that entity theories decrease motivation, learning, and achievement as opposed to incremental theories, which improve these aspects among learners (Carr & Dweck, 2011).

Some studies have examined teachers' views about intelligence and their educational outcomes. One of the pioneer studies was carried out by Lynott and Woolfolk (1994), which revealed that the higher the teachers' ratings of a particular dimension of intelligence, the more they valued educational goals consistent with that dimension of intelligence. Lee (1996) demonstrated that teachers who believed in the entity theory of intelligence treated their students more unequally than those who support the incremental view. Leroy, Bressoux, Sarrazin, and Trouilloud (2007) reported that teachers with a fixed view of intelligence were less likely to create the types of autonomy-supportive climates in their classrooms that could promote students' intrinsic motivation. Jonsson, Beach, Korp, and Erlandson (2012) compared the conceptions of teachers from different disciplines and reported that teachers from language, social science, and practical disciplines had a significant preference for an incremental theory of intelligence while the teachers in mathematics did not. Regarding language teachers' conceptions of intelligence, a study was carried out by Pishghadam (2014), in which some Iranian EFL teachers were interviewed about the relationship between intelligence and language learning. The teachers were then classified into boosters, gloomers, and modulars to represent their classroom behavior. Boosters are of the opinion that intelligence can be increased and has more impact on language learning, while gloomers believe that it is something fixed and has only some effect on language learning and finally, modulars, as the name suggests, believe in modularity. The aforementioned study is one of a kind in ELT, and no similar studies have been reported in the field.

As already stated, previous research has focused on the effect of intelligence on learning in general and on second/foreign language, in particular. A novel look at the connection between intelligence and second/foreign language learning is to think about the impact of learning a second/foreign language on intelligence, in other words, how learning a new language can increase the learners' intelligence level. This new stance has been taken by Pishghadam (2011)

in his theory of Applied ELT, which emphasizes on the effects of ELT classes on the cognitive and emotional aspects of the mind. According to the theory, due to the cognitive and communicative nature of English language learning classes in EFL contexts, Pishghadam (2011) is of the view that psychometric and emotional intelligence can be increased in these classes. In general, he has proposed that a *life syllabus* can be introduced in these classes to expedite the procedure.

## Teacher Care

First popularized by Rogers and Webb (1991), teacher care refers to teacher-initiated practices that foster strong interpersonal bonds with students. It entails maintaining a classroom environment in which the students feel respected and are at the same time respectful of the teacher as the authority figure (Ware, 2006). Teacher caring has been associated with a wide range of positive outcomes including higher attendance, increased time spent studying, improved academic achievement, and lower drop-out rate (see Foster, 2008). High levels of teacher care, in general, have shown to be related to higher levels of autonomous motivation (the sense of unpressured willingness to perform an action); lower anxiety; and optimal instructional related feelings (Bieg, Rickelman, Jones, & Mittag, 2013).

As Kohl (1984) asserted “a teacher has an obligation to care about every student” (p. 66). When the teacher does not give equal care to students, biased relations with students take place (Gomez, Allen, & Clinton, 2004). Teacher biases in the classroom may be based on cultural or performance differences. While cultural biases relate to ideology and culturally aligned ways of thinking, performance biases discriminate against low-performing and high-performing students (Anderman & Anderman, 2009). Teachers’ biases against low-performing students may originate from their conceptions about whether learners’ performance relates more to intelligence or effort (Pishghadam, 2014).

Another important component of teacher care is stroke, which is defined as every action to acknowledge other’s presence and values (Shirai, 2006) in order to satisfy an individual’s need for recognition or their “recognition hunger” (Berne, 1988). Stroke is classified into different types: verbal or non-verbal, positive or negative, conditional or unconditional (Stewart & Joines, 1987). Because of its emphasis on paying attention to students, stroke is closely related to feedback, especially feedback that provides positive and negative evaluations directed at the students (Hattey & Timperley, 2007). According to Freedman (1993), learners who study in a stroke-rich environment achieve higher levels of performance. In a recent study, Pishghadam and Khajavy (in press) developed and validated a Student Stroke Scale and demonstrated that stroke has a positive relationship with extrinsic and intrinsic motivation.

## Teacher Feedback

In the context of teaching, in general, feedback can be defined as “information that is given to the learner about his or her performance of a learning task, usually with the objective of improving this performance” (Ur, 1996, p.242). The notion of feedback, which is closely related to stroke (Hattey & Timperley, 2007) and accordingly teacher caring is considered widely important in education for consolidating learning. The power of feedback lies in the fact that it is taken into account by students and it affects their cognition (Perrenoud, 1998). In a review of evidence related to the impact of feedback on learning and achievement, Hattie and Timperley (2007) examined 12 meta-analyses, which included 196 studies and 6972 effect sizes. The average effect size for the effect of feedback on learning was 0.79, which showed that feedback is indeed powerful in learner achievement.

With regard to theories of second language learning, the importance of feedback is discussed in Long’s Interaction Hypothesis and Vygotsky’s Sociocultural Theory by highlighting teacher-student interactions and the social nature of learning, respectively (see Mitchell & Myles, 2004). When examining the existing scholarship about feedback in language learning classes, different feedback typologies exist including written versus oral, implicit versus explicit, positive or negative and teacher feedback versus peer feedback. Moreover, different opinions abound about the role of feedback, how and when it should be provided, and the effects it leaves on students.

In a general but comprehensive classification, Gattullo (2000) and Harmer (2001) divide feedback given in the language learning classroom into corrective, evaluative, and strategic. The comprehensiveness of this classification lies in the fact that it includes the main types of feedback provided in the language classroom (Gattullo, 2000; Harmer, 2001). Corrective feedback deals with helping learners notice and correct wrong forms or informing them that what they produced is correct. For example, a student may say “Yesterday I come to school at eight o’clock”, and the teacher gives corrective feedback by saying “Yesterday I came to school at eight o’clock”. Corrective feedback itself is divided into different types; including recast, clarification request, metalinguistic feedback, elicitation, repetition and explicit correction (Lyster & Ranta, 1997). As making errors is a necessary and natural part of language learning, error correction is one of the mostly used feedback types in language pedagogy (Hendrickson, 1978). Evaluative feedback is used to pass judgment on learners’ performance and is very common in second and foreign language teaching classes (Gattullo, 2000). For this purpose, words or phrases such as “good”, “excellent”, “poor performance”, etcetera are applied. Finally, strategic feedback provides advice to learners on ways to improve their performance and become more self-reliant by providing them with techniques and channels (Harmer, 2001). For example, for a student who cannot pronounce “the”, the teacher might say “Look at my tongue, put your teeth on your tongue, the.”

## **Purpose of the Study**

The present study attempts to design and validate three scales for investigating language teachers' conceptions of intelligence, learners' evaluation about the feedback the teacher gives to them in the classroom, along with learners' assessment of teacher care. Although a few scales have been designed and validated regarding teachers' conceptions of intelligence (Dweck, 2000; Lynott & Woolfolk, 1994), they lack two requirements: firstly, they were not designed with relation to language learning and secondly, they include only one factor, which is incrementality. Regarding teacher feedback, although some scales have been validated in the general education context (Burnett, 2002) and the language classroom (Aljaafreh & Lantolf, 1994), they do not include the corrective, evaluative, and strategic feedback typology. Moreover, no scale has been validated to measure teacher care specifically. Further purposes of the study are to explore the associations among the subscales of the three scales, the predictability of their factors and the influence of teachers' conceptions of intelligence on how they evaluate their students' ability. Therefore, the present study addresses the following questions:

1. Do the three newly-designed scales (Language Teachers' Conceptions of Intelligence Scale, Language Teacher Feedback Scale, and Teacher Care Scale) demonstrate psychometric properties?
2. Are there any significant relationships among the subscales of the three scales?
3. Do language teachers' conceptions of intelligence significantly affect their rating of their students' ability level?
4. Do language teachers' conceptions of intelligence significantly predict teacher care and teacher feedback?

## **Methodology**

### **Participants and Setting**

There were two groups of participants in the present study: teachers and their students. In order to select the participants, convenience sampling was done. The teacher sample consisted of a total of 81 EFL teachers, working in different private language institutes in Mashhad, a city in northeastern Iran. They included 57 females and 24 males. Their mean age was 26.64 years (standard deviation= 7.6). The student sample consisted of 426 EFL learners, who attended the participating teachers' classes. They included 276 females, 128 males (22 missing). Their mean age was 19.69 years (standard deviation= 6.77). The learners comprised of different proficiency levels from elementary to advanced.

The ELT system in Iran is divided into two sections: the public sector and the private sector. The public system of English language teaching mostly follows the Grammar Translation Method and does not address the communicative aspects of language teaching. The private sector, on the other hand, follows communicative approaches. Therefore, teachers are expected to create a learner-centered atmosphere, devote their attention to the students' needs and feelings and make a great deal of interaction with the students. Moreover, there is no obligation to attend such institutes; therefore learners who attend them are motivated and pay close attention to their

teacher's behavior. In order to highlight these points, the present research was conducted in private language institutes, particularly the most popular ones in the city. The teachers and learners were chosen based on their willingness to participate and all ethical issues of participation were taken closely into consideration.

## **Instrumentation**

### **Language Teachers' Conceptions of Intelligence Scale (LTCI-S)**

This instrument was designed based on three constructs of increasability, modularity, and applied ELT as discussed in the theoretical framework. The scale consisted of 15 items, 5 for each construct, in the form of a 6-point Likert ranging from *Strongly agree* (6) to *Strongly disagree* (1). To check content validity, think-aloud was conducted in order to ensure the comprehensibility of all items and remove any ambiguities. It should be noted that think-aloud is considered an appropriate method for checking readers' understanding of constructs and the comprehensibility, readability and legibility of items in a questionnaire (Dornyei, 2007). For this purpose, five English language teachers were asked to talk about the content of the items as they responded to them. Based on the results, modifications were made to the wording of some of the items (see Appendix A for items).

### **Language Teacher Feedback Scale (LTF-S)**

This scale was constructed based on Gattullo's (2000) and Harmer's (2001) division of feedback into corrective, evaluative, and strategic. This categorization summarizes well what teachers of English usually do when interacting with their students: correcting mistakes, evaluating their performance, and providing techniques to overcome their problems in language learning. A total of 18 items were written in Persian, the participants' mother tongue, on a 6-point Likert-type scale ranging from *Always* (6) to *Never* (1). For the corrective, evaluative, and strategic subscales, 7, 6 and 5 items were conceived of, respectively. Subsequently, five English language learners were asked to respond to the scale, by having one particular English teacher in mind. The researchers asked the learners to give comments about the content of the scale as they responded to it. A few items had to be restated to clear their ambiguities (see Appendix B for items of the English version).

### **Teacher Care Scale (TC-S)**

The Teacher Care Scale (TC-S) was based on a three-factor model of stroke, biased relation with others, and feedback. A total of 20 items were written in Persian on a Likert-type scale of 6 points, ranging from *Always* (6) to *Never* (1). The first 10 items were written about stroke, the next five items were composed regarding biased relations and the succeeding five were about feedback. The piloting process was the same as the one for the LTF-S. The five language learners who were chosen were asked to respond to the items about a particular teacher in their mind and talk about the content of the scale and the comprehensibility of each item. After that, a few changes were made to the wordings based on the reactions of the students (see Appendix C for items of the English version).



## Procedure

After gaining permission from the private language institutes and their teachers, the researchers entered each teacher's classroom and distributed two sets of instruments (the LTICI-S to the teacher, and the LTF-S and TC-S to the learners), which they were supposed to respond about the teacher of that exact class. Since the learners were not all at the same level of English proficiency, the scales given to them were designed in their mother tongue, Persian, so as not to have any comprehension problems. The LTICI-S was in English, though, since it was given to teachers of English, and no comprehension problems were assumed. The design of the research necessitated that the participants write their names on the scales. However, they were assured that their responses would remain confidential. It took 10 and 15 minutes for each teacher and his/her students to respond, respectively. The researchers were present during this time. Afterwards, the researchers asked the teachers to rate each of their students' English proficiency level as low, mid, or high on the basis of their final achievement test. It should be noted that the research was conducted at the end of the term so that there would be a more accurate evaluation of students' performance, and in the same way, students would be able to make better judgments about their teacher's classroom practices.

For the data analysis, first CFA was conducted to validate the scales. Following that, correlations were run to find the relationships among the subscales of the Teachers' Conceptions of Intelligence, Teacher Care, and Teacher Feedback. In order to investigate how teachers' conceptions of intelligence might affect how they evaluate their students, an ANOVA was performed. Finally, multiple regression analyses were performed to test the predictability of teacher feedback by teacher care factors, and the predictability of teacher feedback and teacher care by teachers' conceptions of intelligence factors.

## Results

### Confirmatory Factor Analysis

In order to validate the LTICI-S, TC-S, and LTF-S, CFA was utilized. Based on previous studies and review of the literature, a three-factor model of Teachers' Conceptions of Intelligence (15 items), a three-factor model of Teacher Care (20 items) and three-factor model of Teacher Feedback (18 items) were proposed.

Following this, two separate CFAs were performed. First, LTICI-S model was evaluated. In order to assess fit of the model, goodness-of-fit indices are utilized. In this study, the following goodness-of-fit indices were used: chi square/df, Goodness of fit index (GFI), Comparative Fit Index (CFI), and Root Mean Square Error of Approximation (RMSEA). To have a fit model, chi square/df should be less than 3, CFI and GFI  $>.90$ , and RMSEA  $<.08$  (Hu & Bentler, 1999). The initial model did not show good fit to the data; therefore, some modifications were made. Items 1 ( $\beta = .11, p >.05$ ), 4 ( $\beta = .15, p >.05$ ), and 9 ( $\beta = .07, p >.05$ ) were removed due to low factor loadings which were not significant. The final model showed good fit to the data (Fig. 1). Goodness-of-fit indices can be seen in Figure 1.

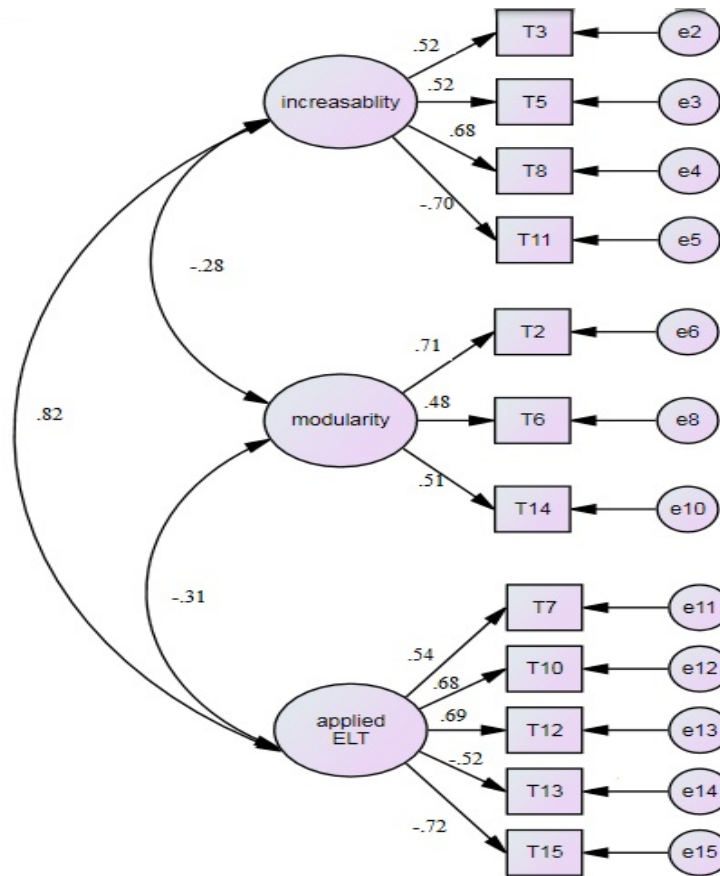

**Fig 1: Final CFA model of Teachers 'Conceptions of Intelligence**

Next, Teacher Feedback model was evaluated. The initial model did not show good fit to the data; therefore, some modifications were made. Items 1 ( $\beta = .13, p > .05$ ), 6 ( $\beta = .09, p > .05$ ), 7 ( $\beta = .07, p > .05$ ), 14 ( $\beta = .18, p > .05$ ), 16 ( $\beta = .13, p > .05$ ) were removed due to low factor loadings, which were not significant. The final model showed good fit to the data (Fig. 2). Goodness-of-fit indices can be seen in Table 1.

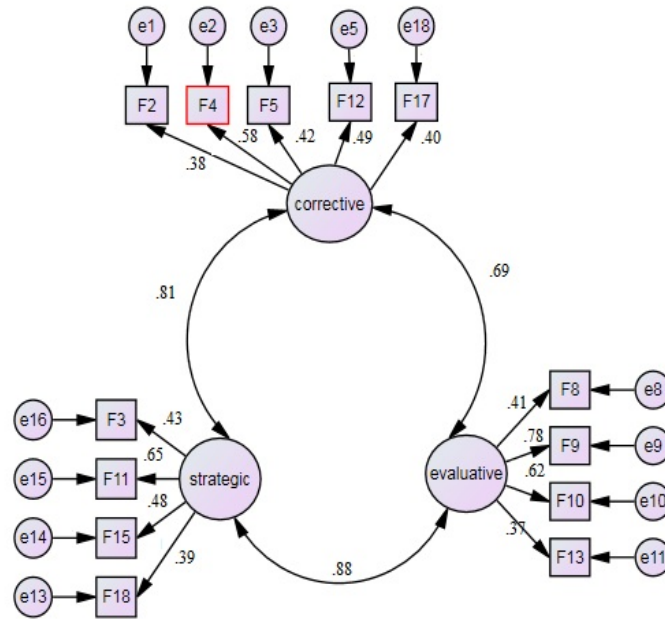

**Fig 2: Final CFA model of Teacher Feedback**

Finally, Teacher Care model was evaluated. The initial model did not show good fit to the data; therefore, some modifications were made. Items 2 ( $\beta = .14, p > .05$ ) and 16 ( $\beta = .09, p > .05$ ) were removed due to low factor loadings, which were not significant. The final model showed good fit to the data (Fig.3). Goodness-of-fit indices can be seen in Table 1.

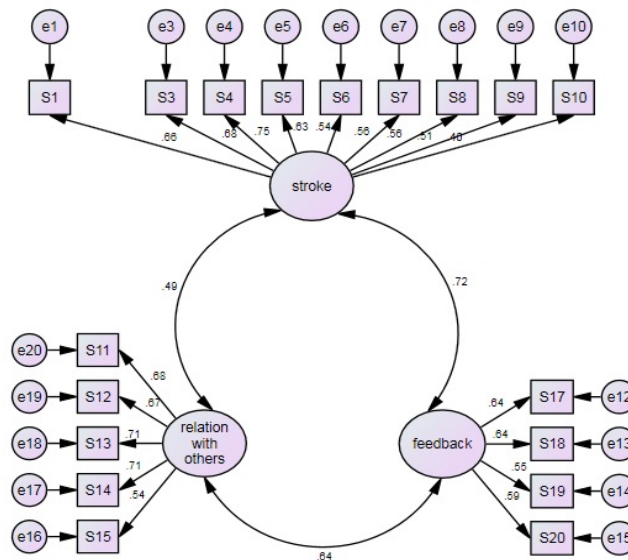

**Fig 3: Final CFA model of Teacher Care**

	$\chi^2$	Df	$\chi^2/df$	GFI	CFI	RMSEA
Teachers' Conception of Intelligence	198.25	83	2.38	.91	.93	.06
Teacher Feedback	194.18	132	1.47	.92	.95	.07
Teacher Care	374.99	130	2.88	.93	.91	.06

**Table 1: Goodness-of-fit indices for scales**

Internal consistency of each scale and their subscales are presented in Table 2. As Table 2 shows, all scales and subscales have Cronbach's alphas above the recommended value of .70, except for increasability ( $\alpha = .63$ ), applied ELT ( $\alpha = .68$ ), and bias relation with others ( $\alpha = .66$ ). Therefore, the results related to these subscales should be treated with more care.

	Number of items	Cronbach's alpha
Corrective feedback	5	.71
Evaluative feedback	4	.72
Strategic feedback	4	.79
Total feedback	13	.84
Increasability	4	.63
Modularity	3	.70
Applied ELT	5	.68
Total Teacher Feedback	12	.76
Stroke	9	.81
Feedback	4	.75
Bias relation with others	5	.66
Total Care	18	.85

**Table 2: Internal consistency of LTCI-S, LTF-S and TC-S and their subscales**

### Descriptive Statistics and Correlations

The descriptive statistics and correlations among the subscales of the teachers' conceptions of intelligence, teacher care, and teacher feedback were examined (Tab. 3). First, the relationships between teachers' conceptions of intelligence and teacher feedback were investigated. As Table 3 shows, there was a negative relationship between corrective feedback with increasability ( $r = -.28, p < .05$ ) and applied ELT ( $r = -.20, p < .05$ ). Moreover, a positive relationship was found between strategic feedback and applied ELT ( $r = .20, p < .05$ ). Therefore, belief in the increasability of intelligence and applied ELT led to less corrective feedback from the teachers to the students. Moreover, teachers who believed in applied ELT provided more strategic feedback to their students. Following this, the relations between teachers' conceptions

of intelligence and teacher care were investigated. Stroke was positively related to modularity ( $r = .31, p < .05$ ) and negatively related to applied ELT ( $r = -.23, p < .05$ ). This finding suggests that teachers who believed in the modularity of mind paid more attention to the students in the classroom, and those who believed in applied ELT paid less attention

Finally, the relations between teacher care and teacher feedback were investigated. Corrective feedback was positively and significantly related to stroke ( $r = .56, p < .05$ ) and feedback ( $r = .22, p < .05$ ), and negatively related to biased relations with others ( $r = -.25, p < .05$ ). Evaluative feedback was negatively related to biased relations with others ( $r = -.27, p < .05$ ) and feedback ( $r = -.39, p < .05$ ). Strategic feedback was also positively and significantly related to stroke ( $r = .39, p < .05$ ). Therefore, corrective feedback and strategic feedback were both positively related to stroke, while corrective feedback and evaluative feedback were both negatively related to biased relations with others.

	Mean (Standard Deviation)	1	2	3	4	5	6	7	8	9
1.increasability	15.69(3.15)	1.00								
2.modularity	10.31(2.97)	-.32**	1.00							
3.applied ELT	17.16(2.38)	.41**	-.29*	1.00						
4.corrective	23.15(2.49)	-.28**	.13	-.20*	1.00					
5.evaluative	15.90(3.16)	-.13	.06	-.15	.32**	1.00				
6.strategic	17.80(2.58)	.15	.02	.20*	.28*	.32**	1.00			
7.stroke	42.38(5.59)	-.15	.31**	-.23*	.56**	.08	.08	1.00		
8.bias	15.31(4.68)	.07	-.10	.03	-.25*	-.27*	-.14	-.27*	1.00	
9.feedback	16.86(3.21)	.02	.03	.09	.22*	-.39**	.07	.34**	-.29	1.00

**Table3: Descriptive statistics and correlations among teachers' conceptions of intelligence, teacher care, and teacher feedback**

### Analysis of Variance (ANOVA)

To examine how teachers with different conceptions of intelligence evaluate their students' ability, an ANOVA was used. Students' ability was a nominal variable with three layers of low, mid, and high. First, descriptive statistics for the three subscales of Teachers' Conceptions of Intelligence were calculated (Tab. 4).

		N	Mean	Std. Deviation	Std. Error	Minimum	Maximum
increasability	low	16	16.7060	3.29085	.82271	12.00	25.30
	mid	50	16.0190	2.91119	.41170	10.00	26.23
	high	13	13.4615	3.23046	.89597	8.00	17.00
	Total	79	15.7373	3.18100	.35789	8.00	26.23
modularity	low	18	10.6984	3.55842	.83873	3.00	16.00
	mid	50	10.1472	2.91202	.41182	3.00	16.00
	high	13	10.6923	2.59437	.71955	5.00	14.00
	Total	81	10.3572	2.99438	.33271	3.00	16.00
applied ELT	low	18	17.5059	2.34585	.55292	13.11	22.00
	mid	48	17.0059	2.40828	.34760	9.40	21.00
	high	13	17.2308	2.65059	.73514	12.00	21.00
	Total	79	17.1568	2.41206	.27138	9.40	22.00

**Table 4: Descriptive statistics for teachers' conceptions of intelligence**

To see whether these differences are statistically significant, F value was calculated. No significant difference was found among the three groups with regard to modularity [ $F(76, 2) = .53, p > .05$ ] and applied ELT [ $F(76, 2) = .92, p < .05$ ]. Only increasability subscale had a significant F value [ $F(76, 2) = 4.66, p < .05$ ]. Post hoc analysis with Tukey was run to see the exact point of difference. Results of post hoc analysis showed a significant difference between low and high (mean difference = 3.24,  $p < .05$ ), and mid and high (mean difference = 2.55,  $p < .05$ ) ability levels of the students with regard to the teachers' conception of increasability of intelligence. It can be implied that those teachers who had a higher rating of increasability of intelligence saw their students' ability lower than those who had a lower rating of increasability of intelligence.

### Regression Analyses

The first regression was performed to examine the predictability of teacher feedback by teachers' conceptions of intelligence (increasability, modularity, and applied ELT). Among the three regressions completed, only one of them was significant. Teachers' conceptions of intelligence accounted for 8% of the variance in corrective feedback [ $F(3, 74) = 2.95, p < .05$ ,  $Adj R^2 = .08$ ]. Increasability ( $\beta = -.26, t = -2.34, p < .05$ ) was the only significant predictor of corrective feedback (Tab. 5). Therefore, it can be predicted that teachers who believe in increasability of intelligence, provide less corrective feedback to their students.

Factor	predictor	beta	t
corrective feedback	increasibility	-.26	-2.34*
	modularity	.05	.49
	applied ELT	.13	1.16
	F(3,74)	2.95*	
	Adj R <sup>2</sup>	.08	
evaluative feedback	increasibility	-.16	-1.45
	modularity	.06	.56
	applied ELT	-.19	-1.68
	F(3,74)	1.49	
	Adj R <sup>2</sup>	.01	
strategic feedback	increasibility	.11	.97
	modularity	.01	.12
	applied ELT	-.17	-1.48
	F(3,74)	1.29	
	Adj R <sup>2</sup>	.01	

**Table 5: Multiple regressions with teachers' intelligence conception variables as predictors of teacher feedback**

The last regression was performed to examine the predictability of the teacher care by teachers' conceptions of intelligence (increasibility, modularity, and applied ELT). Among the three regressions completed, only one of them was significant. Teachers' conceptions of intelligence accounted for 11% of the variance in stroke [ $F(3, 74) = 3.92, p < .01, \text{Adj } R^2 = .11$ ]. Modularity ( $\beta = .26, t = 2.44, p < .01$ ) was the only significant predictor of stroke (Tab. 6). Therefore, from the three subconstructs of teachers' conceptions of intelligence, only modularity was found to be a significant predictor of teacher care. It can be predicted that teachers who believe in the modularity of the mind, provide their students with more stroke.

Factor	predictor	beta	t
stroke	increasibility	-.11	-.97
	modularity	.26	2.44**
	applied ELT	.18	1.60
	F(3,74)	3.92**	
	Adj R <sup>2</sup>	.11	
bias	increasibility	.08	.68
	modularity	-.08	-.74
	applied ELT	.06	.51
	F(3,74)	.40	
	Adj R <sup>2</sup>	.03	
feedback	increasibility	.01	.04
	modularity	-.02	-.19
	applied ELT	.09	.77
	F(3,74)	.21	
	Adj R <sup>2</sup>	.02	

**Table 6: Multiple regressions with teachers' intelligence conception variables as predictors of teacher care**

## Discussion

This study sought to design and validate three scales and examine the associations among them. Based on the review of literature, a three-factor model of Language Teacher's Conceptions of Intelligence (15 items), a three-factor model of Teacher Care (20 items) and a three-factor model of Teacher Feedback (18 items) were proposed. In order to address the first research question, CFA was run, and some items were removed from the model due to their low factor loadings. The LTCI-S resulted in a 12 item scale, the TC-S became 18 items, and 5 items were removed from the LTF-S, making it 13 items in total.

As for the second research question, some noteworthy results were found regarding the relationship between teachers' conceptions of intelligence with their feedback and also the amount of care they devoted to their students. Among the subscales of teacher feedback, the only factor that had a positively significant relationship with applied ELT was strategic feedback. This means that teachers who believed that using strategies to improve language learning and that solving problems and difficulties in the language learning process could increase intelligence gave more strategic feedback to their students. By providing strategic feedback, they made students independent learners and more reliant on themselves, thus making them able to use their language learning experience in other domains of life (Pishghadam, 2011). Moreover, applied ELT had a significantly negative relationship with corrective feedback. Therefore, teachers who had the conception that learning English can increase learners' intelligence were less concerned with giving corrective feedback. A highlighted feature of applied ELT includes moving beyond language classes to language- and- life classes by implementing 'life syllabus' in the classroom. This syllabus directs English teachers to give priority to life issues rather than language in class, and thus primacy is given to the improvement of learners' life qualities (Pishghadam, 2011). It seems that teachers who are in favor of this outlook do not preoccupy themselves and their students with form and accuracy, but pay more attention to providing strategic feedback, which paves the way for better learning in general (Gattullo, 2000; Harmer, 2001).

A significantly positive relationship was also discovered between modularity and stroke, which indicates that teachers who separate general intelligence from language learning ability pay more attention to their students in class and are more willing to establish rapport with them. These teachers look at students as individuals who are there to learn a new language, regardless of whether they are intelligent or not. As put by Jarvis (2005), teachers who believe in MI theory and accordingly modularity, organize their classroom environment in a way to enable students to become more successful learners and to develop the "whole person".

With regard to the association between teacher feedback and teacher care, both corrective and strategic feedback positively correlated with stroke, implying that teachers who pay more attention to their students provide more feedback to them. Furthermore, corrective and evaluative feedback negatively correlated with biased relations with other students, demonstrating that teachers who are more aware of giving feedback to their students, distribute their attention more equally in the classroom and try not to favor the high-ability students over the low-ability ones.

Regarding the third research question, a significant finding was that those teachers who had a higher rating of increasibility of intelligence saw their students' ability lower than those who had a lower rating of increasibility of intelligence. This implies that teachers who believe that intelligence is not a fixed trait and that it can be increased by the environment have higher



expectations from their students in their performance than those teachers who see intelligence as inflexible and stable. Past research has shown that students who endorse incremental theories of intelligence have higher academic performance than those who approve of the entity theory (Braasch, Braten, Stromso, & Anmarkrud, 2014; Good, Aronson, & Inzlicht, 2003). The results of this study indicate that likewise, teachers who support the incremental theory of intelligence see higher potentials in students and therefore rate their performance lower than teachers who have the opposite view.

The fourth research question was addressed by finding the predictability of teacher care and teacher feedback by teachers' conceptions of intelligence factors. Regarding the predictability of teacher feedback by intelligence conceptions, only increasability was found to have significant predictability for corrective feedback. However, the relationship was negative, meaning that those teachers who believed in the malleability of intelligence gave less corrective feedback to their students. One justification may be that teachers who believe intelligence is susceptible to being increased through effort, let students find the correct answer themselves, instead of providing them with the correct form. However, this part of the results calls for further investigation, especially regarding the specific types of corrective feedback (Lyster & Ranta, 1997).

Finally, in relation to the predictability of teacher care by intelligence conceptions, modularity was found as a significant predictor of stroke, confirming the correlation result obtained in the previous part that teachers who see intelligence as non-influential in language learning provide their students with more stroke. It also corroborates Pishghadam (2014), demonstrating that modulars care more about their students, know their names, and distribute their eye contact equally. As already mentioned, separating language learning from intelligence, creates a more relaxing and comfortable environment in the language classroom. This paves the way for more stroke, and as reported by Pishghadam and Khajavy (in press), leads to higher extrinsic and intrinsic motivation.

This study has a number of implications. The first group of implications lies in applying the scales developed. All three scales can be used as teacher evaluation instruments in different educational settings. The LTF-S could be used to assess teachers' feedback practices in language learning classrooms; the TC-S could be applied as a teacher evaluation instrument not only in language learning, but in all subject area classrooms and the LTCI-S can be employed as an evaluation or even recruitment instrument for language teachers.

Other implications are based on the results of the study. Since the findings have highlighted a significantly positive relationship between belief in modularity and devoting more care to students, attempts should be made to remove prejudgments about students' intelligence level in language learning classrooms. Instead, the language learning classroom should be seen as an opportunity to enhance students' intelligence. Taking into account that teacher care is a predictor of corrective feedback and the significance of corrective feedback in interlanguage development (Hendrickson, 1978), teachers should be aware of devoting more care to their students, by providing them with stroke, general feedback, and not displaying biases between high and low performing students. The results have also underscored the important role of teachers' conceptions of intelligence in their classroom practices. Given the significance of pre-service education in reinforcing or changing belief systems (Koc, 2013), teacher educators should work on the conceptions of student teachers about intelligence by instructing them to have a modular, malleable and incremental view of the construct. Moreover, the significance of

teacher care and teacher feedback needs to be brought into student teachers' attention so that they know how to make a link between their conceptions and their classroom practices.

Results of this study should be interpreted in light of some limitations. First of all, the findings are contextualized by an Iranian sample of teachers and students. Also, it was carried out only in private language institutes, which is an informal setting, and so the results may not be generalizable to formal ones, such as public schools. Furthermore, only correlational procedures were employed to examine the relations among the constructs. The proficiency level of learners and experience rate of teachers were also not controlled, which may have been important variables. The sources of the teachers' conceptions remain uninvestigated as well.

In the end, future studies could be conducted to revalidate the scales with other statistical techniques such as Rasch Analysis or with larger sample populations. More investigations need to be carried out to see whether similar results might be obtained from other educational settings and subject areas. Further research could be done to examine the predictability of the scales with different variables such as teacher success and language achievement. This study has highlighted the connection between teacher cognition and teacher practice. More studies of this kind need to be done to track the source of classroom practices, through delving into teachers' conceptions about different constructs.

## References

- Ajzen, I. (2005). *Attitudes, personality and behavior* (2<sup>nd</sup> ed.). New York: Open University Press.
- Aljaafreh, A., & Lantolf, J. P. (1994). Negative feedback as regulation and second language learning in the zone of proximal development. *The Modern Language Journal*, 78(4), 465-483. <http://dx.doi.org/10.1111/j.1540-4781.1994.tb02064.x>
- Anderman, E.M., & Anderman, L.H. (2009). *Psychology of classroom learning: An Encyclopedia*. USA: Macmillan Reference.
- Bandura, M., & Dweck, C.S. (1981). *The relationship of conceptions of intelligence and achievement goals to achievement-related cognition, affect and behavior*. Unpublished manuscript, Harvard University.
- Berne, E. (1988). *Games people play*. New York: Grove Press.
- Bieg, S., Rickelman, R.J., Jones, J.P., & Mittag, W. (2013). The role of teachers' care and self-determined motivation in working with students in Germany and the United States. *International Journal of Educational Research*, 60, 27-37. <http://dx.doi.org/10.1016/j.ijer.2013.04.002>
- Braasch, J.L.G., Braten, I., Stromso, H.I., & Anmarkrud, O. (2014). Incremental theories of intelligence predict multiple document comprehension. *Learning and Individual Differences*, 31, 11-20. <http://dx.doi.org/10.1016/j.lindif.2013.12.012>
- Brown, G. T. L. (2008). *Conceptions of assessment: Understanding what assessment means to teachers and students*. New York: Nova Science Publishers.
- Burnett, P.C. (2002). Teacher praise and feedback and students' perceptions of the language classroom. *Educational Psychology: An International Journal of Experimental Educational Psychology*, 22(1), 5- 16. <http://dx.doi.org/10.1080/01443410120101215>
- Carr, P.B., & Dweck, C.S. (2011). Intelligence and motivation. In R.J. Sternberg & S.B. Kaufman (Eds.), *The Cambridge handbook of intelligence* (pp. 748–70). New York:

- Cambridge University Press. <http://dx.doi.org/10.1017/CBO9780511977244.038>
- Chamorro-Premuzic, T. (2007). *Personality and individual differences*. Oxford: Blackwell.
- Dornyei, Z. (2005). *The psychology of language learner: Individual differences in second language acquisition*. Mahwah, NJ: Lawrence Erlbaum.
- Dornyei, Z. (2007). *Research methods in applied linguistics*. Oxford: Oxford University Press.
- Dweck, C. (2000). *Self-theories: Their role in motivation, personality, and development*. Philadelphia, PA: Psychology Press.
- Ellis, R. (2008). *The study of second language acquisition*. Oxford: Oxford University Press.
- Elsabbagh, M., & Karmiloff-Smith, A. (2006). Modularity of mind and language. In K. Brown (Ed.), *The encyclopedia of language and linguistics*: Vol. 8. (pp. 218-224). Oxford: Elsevier.
- Faria, L. (1998). Personal conceptions of intelligence, attributions and school achievement: Development of a comprehensive model of inter-relations during adolescence. *Psicologia: Revistada Associacao Psicologia*, 12, 101-113.
- Foster, K.C. (2008). The transformative potential of teacher care as described by students in higher education access initiative. *Education and Urban Society*, 41(1), 104-126. <http://dx.doi.org/10.1177/0013124508321591>
- Freedman, M. (1993). *The kindness of strangers: Adult mentors, urban youth and the new volunteerism*. San Francisco: Jossey-Bass Publishers.
- Ganschow, L., & Sparks, R. (2001). Learning difficulties and foreign language learning: A review of research and instruction. *Language Teaching*, 34, 79-98.
- Gardner, H. (1993). *Multiple intelligences: The theory and practice*. New York: Basic Books.
- Gattullo, F. (2000) Corrective feedback and teaching style: exploring a relationship. In Moon, J. & Nikolov.M. (Eds.), *Researching into English teaching for young learners*. Pecs: University of Pecs Press.
- Good, C., Aronson, J., & Inzlicht, M. (2003). Improving adolescents' standardized test performance: An intervention to reduce the effects of stereotype threat. *Journal of Applied Developmental Psychology*, 24, 645-662. <http://dx.doi.org/10.1016/j.appdev.2003.09.002>
- Gomez, M.L., Allen, A.R., & Clinton, K. (2004). Cultural models of care in teaching: A case study of one pre-service secondary teacher. *Teaching and Teacher Education*, 20, 473-488. <http://dx.doi.org/10.1016/j.tate.2004.04.005>
- Gottfredson, L. (1998). The general intelligence factor. *Scientific American*, 9(4), 24-29.
- Harmer, J. (2001). *The practice of English language teaching* (3rd ed.). London: Longman.
- Hattie, J., & Timperley, H. (2007). The power of feedback. *Review of Educational Research*, 77, 81-112. <http://dx.doi.org/10.3102/003465430298487>
- Hendrickson, J. (1978). Error correction in foreign language teaching: Recent theory, research, and practice. *The Modern Language Journal*, 62, 387-398.
- Hu, L. T., & Bentler, P.M. (1999). Cutoff criteria for fit indexes in covariance structure analysis: Conventional criteria versus new alternatives. *Structural Equation Modeling*, 6, 1-55. <http://dx.doi.org/10.1080/10705519909540118>
- Jarvis, M. (2005). *The psychology of effective learning and teaching*. Nelson Thornes Ltd.
- Jonsson, A.C., Beach, D., Korp, H., & Erlandson, P. Teachers' implicit theories of intelligence: influences from different disciplines and scientific theories. *European Journal of Teacher Education*, 35(4), 387-400.

- Koc, M. (2013). Student teachers' conceptions of technology: A metaphor analysis. *Computers & Education*, 68, 1-8. <http://dx.doi.org/10.1016/j.compedu.2013.04.024>
- Kohl, H. (1984). *Growing minds*. New York: Harper & Row.
- Lee, K. (1996). A study of teacher responses based on their conceptions of intelligence. *Journal of Classroom Interaction*, 31, 1-12.
- Leroy, N., Bressoux, P., Sararzin, P., & Trouilloud (2007). Impact of teachers' implicit theories and perceived pressure on the establishment of an autonomy supportive classroom. *European Journal of Psychology of Education*, 22(4), 529-545. <http://dx.doi.org/10.1007/BF03173470>
- Lynott, D.J., & Woolfolk, A.E. (1994). Teachers' implicit theories of intelligence and their educational goals. *The Journal of Research and Development in Education*, 27(4), 253-264.
- Lyster, R., & Ranta, L. (1997). Corrective feedback and learner uptake: Negotiation of form in communicative classrooms. *Studies in Second Language Acquisition*, 19, 37-66. <http://dx.doi.org/10.1017/S0272263197001034>
- Mitchell, R., & Myles, F. (2004). *Second language learning theories* (2<sup>nd</sup> ed.). UK: Hodder Arnold.
- Perrenoud, P. (1998). From formative evaluation to a controlled regulation of learning processes: Towards a wider conceptual field. *Assessment in Education: Principles, Policy & Practice*, 5(1), 85-102.
- Pishghadam, R. (2011). Introducing Applied ELT as a new approach in second/foreign language studies. *Iranian EFL Journal*, 7(2), 8-14.
- Pishghadam, R. (2014, April 8). *Social conceptions of intelligence and their influence on English language teacher care*. Paper presented at the 2014 Annual International Conference on LSP and Specialized Translation Skills Training.
- Pishghadam, R., & Khajavy, G.H. (in press). Development and validation of the student stroke scale and examining its relation with academic motivation. *Studies in Educational Evaluation*, 40(2), 1-15.
- Pretzlic, U., Olsson, J., Nabuco, M.E., & Cruz, I. (2003). *Cognitive Development*, 18, 579-600. <http://dx.doi.org/10.1016/j.cogdev.2003.09.008>
- Primi, R., Ferrao, M. E., & Almeida, L. (2010). Fluid intelligence as a predictor of learning: A longitudinal multilevel approach applied to mathematics. *Learning and Individual Differences*, 20, 446-451.
- Rogers, D., & Webb, J. (1991). The ethic of caring in teacher education. *Journal of Teacher Education*, 42(3), 173-181. <http://dx.doi.org/10.1177/002248719104200303>
- Shirai, S. (2006). How transactional analysis can be used in terminal care. *International Congress Series*, 1287, 179-184. <http://dx.doi.org/10.1016/j.ics.2005.12.052>
- Sparks, R., & Artzer, M. (2000). Foreign language learning, hyperlexia, and early word recognition. *Annals of Dyslexia*, 50, 189-211.
- Spearman, C. (1904). "General intelligence," objectively determined and measured. *The American Journal of Psychology*, 15(2), 201-292. <http://dx.doi.org/10.2307/1412107>
- Sternberg, R. (1985). *Beyond IQ: A triarchic theory of human intelligence*. New York: Cambridge University Press.
- Sternberg, R. (2002). The theory of successful intelligence and its applications for language-aptitude testing. In P. Robinson (Ed.), *Individual differences and instructed language*

*learning* (pp. 13-43). Amsterdam: John Benjamins. <http://dx.doi.org/10.1075/llt.2.04ste>  
 Stewart, I., & Joines, V. (1987). *TA today: A new introduction to transactional analysis*. Nottingham: Lifespace.  
 Teele, S. (2000). *Rainbows of intelligence: Exploring how students learn*. Thousand Oaks, Calif.: Corwin Press.  
 Ur, P. (1996). *A course in language teaching*. Cambridge: Cambridge University Press.

### Acknowledgements

We gratefully acknowledge the project reported here was supported by a grant-in-aid of research from Ferdowsi University of Mashhad in 2014 (contract code: 30251) without which this research would not have been possible.

### Appendices

#### Appendix A

Language Teachers' Conceptions of Intelligence Scale (LTCl-S)

#	Statement	Strongly agree	Mostly agree	Moderately agree	Slightly agree	Mostly disagree	Strongly disagree
1	Intelligence is genetic.						
2	Intelligent people are better at learning second/foreign languages.						
3	Intelligence can be increased by learning and studying.						
4	Learning a second/foreign language successfully is a matter of hard work, <b>not</b> intelligence.						
5	The environment people live in can affect their level of intelligence.						
6	Students who have difficulty learning a second/foreign language are <b>not</b> intelligent.						

7	Learning a second/foreign language can increase intelligence.						
8	Teachers are able to increase students' level of intelligence.						
9	Learning languages is related to a specific type of intelligence.						
10	Using strategies to improve second/foreign language learning can increase intelligence.						
11	Nothing can be done to increase unintelligent people's intelligence.						
12	Solving problems and difficulties in learning a second/foreign language can increase intelligence.						
13	Learning another language <b>does not</b> have an effect on intelligence.						
14	Some people have a special talent for learning languages, which is <b>not</b> related to their intelligence.						
15	Intelligence <b>cannot</b> be increased by learning a second/foreign language.						

**Appendix B**

**Language Teachers Feedback Scale (LTF-S)**

My teacher...	Always	Usually	Often	Sometimes	Rarely	Never
1 Encourages me to try hard in learning English						
2 Explicitly corrects me when I make a mistake						
3 Teaches me strategies to make up for my mistakes						
4 Encourages me when I give a correct response						
5 Makes me aware of my mistake by his/her look						
6 Expects me to have a good performance under all conditions						
7 Ignores my mistakes						
8 Compares me with myself, not with other students						
9 Amplifies my mistakes						
10 Attributes my mistakes to lack of competence and talent						
11 Makes learning English look like a difficult process						
12 Does not show any reaction after I speak in class						
13 Talks about my poor performance to myself and not in front of others						
14 Encourages or punishes me with smiles or frowns						
15 Emphasizes more on my abilities than my weaknesses						
16 Asks other students to correct my mistakes						
17 Tries to have me find the correct response by myself						
18 Teaches me to use my other abilities in learning English						

**Appendix C**

**Teacher Care Scale (TC-S)**

My teacher...	Always	Usually	Often	Sometimes	Rarely	Never
1 Pays attention to me						
2 Knows my name						
3 Encourages me						
4 Devotes enough time to me in class						
5 Uses my knowledge in the class						
6 Checks my homework						
7 Asks me questions						
8 Lets me ask questions						
9 Devotes enough time to me outside the class						
10 Responds to my phone calls and emails						
11 Pays less attention to the weak students						
12 Devotes more time to high-ability students						
13 Does not let weak students ask questions in class						
14 Asks high-ability students more questions						
15 Compliments high-ability students in front of the others						
16 Does not correct my mistakes quickly						
17 Does not pay attention to what I say						
18 Carefully answers my questions						
19 Becomes angry when I make a mistake						
20 Encourages me when I give a correct response						