

Edith Cowan University
Research Online

Theses: Doctorates and Masters

Theses

2010

Impact of static stretch and muscular contractions on force production within the human triceps surae muscle-tendon complex

Anthony D. Kay
Edith Cowan University

Follow this and additional works at: <https://ro.ecu.edu.au/theses>

 Part of the [Musculoskeletal, Neural, and Ocular Physiology Commons](#)

Recommended Citation

Kay, A. D. (2010). *Impact of static stretch and muscular contractions on force production within the human triceps surae muscle-tendon complex*. <https://ro.ecu.edu.au/theses/123>

This Thesis is posted at Research Online.
<https://ro.ecu.edu.au/theses/123>

Edith Cowan University

Copyright Warning

You may print or download ONE copy of this document for the purpose of your own research or study.

The University does not authorize you to copy, communicate or otherwise make available electronically to any other person any copyright material contained on this site.

You are reminded of the following:

- Copyright owners are entitled to take legal action against persons who infringe their copyright.
- A reproduction of material that is protected by copyright may be a copyright infringement. Where the reproduction of such material is done without attribution of authorship, with false attribution of authorship or the authorship is treated in a derogatory manner, this may be a breach of the author's moral rights contained in Part IX of the Copyright Act 1968 (Cth).
- Courts have the power to impose a wide range of civil and criminal sanctions for infringement of copyright, infringement of moral rights and other offences under the Copyright Act 1968 (Cth). Higher penalties may apply, and higher damages may be awarded, for offences and infringements involving the conversion of material into digital or electronic form.

The Impact of Static Stretch and
Muscular Contractions on Force
Production within the Human Triceps
Surae Muscle-Tendon Complex

Anthony David Kay

2010

Doctor of Philosophy

USE OF THESIS

The Use of Thesis statement is not included in this version of the thesis.

Declaration

I certify that this thesis does not, to the best of my knowledge and belief:

(i) incorporate without acknowledgement any material previously submitted for a degree or diploma in any institution of higher education;

(ii) contain any material previously published or written by another person except where due reference is made in the text; or

(iii) contain any defamatory material.

I also grant permission for the Library at Edith Cowan University to make duplicate copies of my thesis as required.

Signed _____

Anthony D. Kay

Date 03/02/2010

Acknowledgements

I would like to thank my supervisor Tony Blazeovich for his continual support and professional excellence throughout my studies, the participants for taking part in the studies and my colleagues Tony Baross and Chris Talbot for their daily roles as soundboards to all aspects of my research.

Thesis Abstract

Pre-performance routines commonly include stretching and intense muscular contractions in an attempt to optimise muscular performance and reduce injury risk. However, the isolated and combined effects of stretching and muscle contractions on neuromuscular performance are not well described. The aims of this research were to examine the effects of acute static stretch and intense muscular contractions on force production of the human plantarflexors and to examine possible mechanical and neuromuscular mechanisms underpinning any changes. Techniques including isokinetic dynamometry, electromyography (EMG), sonography and motion analysis were used in three studies on recreationally active human volunteers ($n=20$). In the first study, three 60-s passive stretches was found to significantly reduce concentric plantarflexor joint moment (5.0%; $P<0.05$), which was correlated ($r = 0.81$; $P<0.01$) with a reduction in EMG amplitude (9.2%; $P<0.05$). No reduction in Achilles tendon stiffness or gastrocnemius medialis (GM) muscle operating length was found, and all measures recovered by 30 min. This indicates that post-stretch force losses are transient and are largely associated with reduced neuromuscular activity (EMG amplitude) rather than changes in the muscles' operating lengths. Nonetheless, strong muscular contractions, commonly performed during pre-performance routines and incorporated into research designs, may influence the effects of stretch. In the second study it was found that six 8-s maximal isometric contractions reduced Achilles tendon stiffness (10.9%; $P<0.01$) and passive joint moment (4.9%; $P<0.01$) and also significantly reduced concentric moment (11.5%; $P<0.01$), which was again correlated ($r = 0.90$; $P<0.01$) with a reduction in EMG amplitude (21.0%; $P<0.01$). Importantly, a subsequent bout of static stretch, which was identical to that used in study 1, did not result in a further change in any measure ($P > 0.05$). Whilst concentric moment and EMG recovered 30 min later, the decreases in Achilles tendon stiffness and passive moment remained. Thus, the normal stretch-induced reductions in force production were removed when isometric contractions were performed prior to stretch, but this was because concentric strength and neuromuscular activity were already affected; the reduction in concentric moment without a decrease in isometric moment indicates a contraction mode-specific response. The final study revealed that the use of concentric contractions (6×8-s) also resulted in similar reductions in Achilles tendon stiffness (11.7%; $P<0.01$) and concentric joint moment (6.6%; $P<0.01$) as the isometric contractions, and these were correlated ($r = 0.94$; $P<0.01$) with a reduction in EMG amplitude (10.2%; $P<0.01$). However, a further reduction in concentric moment was detected following an identical bout of static stretch (5.8%; $P<0.01$) with no further change in EMG. Importantly, EMG recovered 30 min later while concentric moment remained depressed (9.2%; $P<0.01$), indicating a muscle-based mechanism for these force losses. No reduction in GM muscle operating length was found, removing this as a mechanism underpinning the losses in force. The findings from the present series of studies have important implications for research study design as the warm-up imposed on subjects prior to stretch seems to strongly influence the impact of stretch. Furthermore, the results also have important practical implications in the formulation of pre-performance routines where maximal force production in the plantarflexors is an important goal.

Table of Contents

Page iii	Use of thesis copyright statement
Page iv	Declaration
Page v	Acknowledgements
Page vi	Thesis Abstract
Page viii	List of Tables & Figures
Page xii	Publications Arising from the Research
Page 1	Chapter 1 Introduction
Page 5	Chapter 2 Literature Review
Page 26	Chapter 3 Study 1 – Moderate-duration static stretch reduces active and passive plantarflexor moment but not Achilles tendon stiffness or active muscle length
Page 60	Chapter 4 Study 2 – Isometric contractions reduce plantarflexor moment, Achilles tendon stiffness and neuromuscular activity but remove the subsequent effects of stretch
Page 83	Chapter 5 Study 3 – Concentric muscle contractions prior to static stretching minimise but do not remove stretch-induced force deficits
Page 101	Chapter 6 General Discussion of the Present Research
Page 108	References
Page 120	Appendix 1 – Power Analyses
Page 123	Appendix 2 – Ethics form, informed consent form, participant information sheet, recruitment poster, risk assessment
Page 134	Appendix 3 – Repeated measures ANOVA tables

List of Tables & Figures

- Table 2.7.1. Effects of passive stretch on muscular performance without prior warm-up.
- Table 2.7.2. Effects of passive stretch on muscular performance with prior warm-up.
- Table 3.3.1. Linear regression calculations for ultrasound data sampled at 4.67 Hz.
- Table 3.4.1. Intraclass correlation coefficients (ICCs) & coefficients of variation (CVs) for concentric and passive joint moment, TS EMG, Achilles tendon length and stiffness and gastrocnemius medialis (GM) muscle length within the no stretch (control) condition.
- Table 3.4.2. Repeated measures ANOVA for normalised moment during maximal concentric plantarflexion trials.
- Table 3.4.3. Repeated measures ANOVA for normalised gastrocnemius lateralis (GL), gastrocnemius medialis (GM), soleus (Sol), triceps surae (TS) and tibialis anterior (TA) electromyographic (EMG) amplitude.
- Table 3.4.4. Repeated measures ANOVA for moment during passive dorsiflexion trials.
- Table 3.4.5. Repeated measures ANOVA for gastrocnemius medialis (GM) muscle length, Achilles tendon length and stiffness during maximal concentric plantarflexion trials.
- Table 3.4.6. Repeated measures ANOVA for Achilles tendon and gastrocnemius medialis (GM) muscle length during passive dorsiflexion trials.
- Table 4.4.1. Repeated measures ANOVA for normalised moment during maximal concentric plantarflexion trials.
- Table 4.4.2. Repeated measures ANOVA for normalised gastrocnemius lateralis (GL), gastrocnemius medialis (GM), soleus (Sol), triceps surae (TS) and tibialis anterior (TA) electromyographic (EMG) amplitude during maximal concentric plantarflexion trials.
- Table 4.4.3. Repeated measures ANOVA for normalised joint moment during passive trials.
- Table 4.4.4. Repeated measures ANOVA for gastrocnemius medialis (GM) muscle length, Achilles tendon length and stiffness during maximal concentric plantarflexion trials.
- Table 4.4.5. Repeated measures ANOVA for Achilles tendon length and gastrocnemius medialis (GM) muscle length during passive trials.
- Table 5.4.1. Repeated measures ANOVA for normalised moment during maximal concentric plantarflexion trials.
- Table 5.4.2. Repeated measures ANOVA for normalised gastrocnemius lateralis (GL), gastrocnemius medialis (GM), soleus (Sol), triceps surae (TS) and tibialis anterior (TA) electromyographic (EMG) amplitude during maximal concentric plantarflexion trials.

- Table 5.4.3. Repeated measures ANOVA for normalised joint moment during passive trials.
- Table 5.4.4. Repeated measures ANOVA for gastrocnemius medialis (GM) muscle length, Achilles tendon length and stiffness during maximal concentric plantarflexion trials.
- Table 5.4.5. Repeated measures ANOVA for Achilles tendon length and gastrocnemius medialis (GM) muscle length during passive trials.
- Figure 2.2.1. Excitatory and inhibitory neuromuscular input (from Wilmore & Costill, 1999).
- Figure 2.2.2. Principle of orderly recruitment.
- Figure 2.2.3. Calcium release following an action potential (from Wilmore & Costill, 1999).
- Figure 2.3.1. Muscle hierarchical structure (from Wilmore & Costill, 1999).
- Figure 2.3.2. Myofilament arrangement of the sarcomere (Wilmore & Costill, 1999).
- Figure 2.3.3. Cross-sectional hexagonal actin-myosin arrangement (from McArdle et al., 2001).
- Figure 2.3.4. Hierarchical structure of the tendon (from McArdle et al., 2001).
- Figure 2.4.1. Mechanical schematic of the muscle-tendon complex (MTC) (from McNair & Stanley, 1996).
- Figure 2.5.1. Active force-length characteristics of skeletal muscle.
- Figure 2.5.2. Stiff & compliant stress-strain characteristics of an elastic material.
- Figure 2.5.3. Force-length characteristics of the muscle-tendon complex (MTC).
- Figure 3.3.1. Joint moment and EMG during passive trial.
- Figure 3.3.2. Passive ankle joint moment recorded during a slow ($5^{\circ}\cdot^{-1}$) dorsiflexion rotation.
- Figure 3.3.3. Joint moment recorded during a concentric plantarflexion trial.
- Figure 3.3.4. Fast fourier transformation (FFT) depicting the spectral frequency of the filtered EMG signal.
- Figure 3.3.5. EMG processing.
- Figure 3.3.6. Correlation between soleus (Sol; A), gastrocnemius lateralis (GL; B), gastrocnemius medialis (GM; C), and triceps surae (TS; D) electromyographic amplitude (EMG) and joint moment.
- Figure 3.3.7. Correlation between tibialis anterior (TA) electromyographic amplitude (EMG) and dorsiflexor joint moment.
- Figure 3.3.8. Reflective marker (motion analysis) and ultrasound probe positioning.
- Figure 3.3.9. Camera, reflective marker and orthogonal plane positions within the calibrated volume.
- Figure 3.3.10. Motion analysis data for estimated Achilles tendon length during passive (A) and active concentric (B) trials.
- Figure 3.3.11. Achilles tendon length between pilot testing trials during passive trials at 10%, 30%, 50%, 70% and 90% of ROM.
- Figure 3.3.12. Ultrasound image of gastrocnemius medialis (GM)-Achilles tendon junction.
- Figure 3.3.13. Transistor-transistor linear (TTL) pulse and joint angle synchronisation.
- Figure 3.3.14. Achilles tendon excursion calculated for one passive trial at 28 Hz and 4.67 Hz.

- Figure 3.3.15. Intra-tester digitisation reliability of muscle-tendon junction (MTJ) displacement measured at 10%, 30%, 50%, 70% and 90% of ROM.
- Figure 3.4.1. Concentric (A) and passive plantarflexor joint moment (B), triceps surae (TS) EMG (C), gastrocnemius medialis (GM) muscle length (D), Achilles tendon stiffness (E) and stiffness (F) within the no stretch (control) condition at 10%, 30%, 50%, 70% and 90% of ROM. M_{pas} - percentage of maximal joint moment recorded during passive trial.
- Figure 3.4.2. Concentric joint moment during active plantarflexion trials.
- Figure 3.4.3. Triceps surae (TS) electromyographic (EMG) amplitude during maximal concentric plantarflexion within the stretch condition.
- Figure 3.4.4. Correlations between post-stretch reductions in concentric joint moment and triceps surae (TS) electromyographic (EMG) amplitude (A = 50%; B = 70% of ROM).
- Figure 3.4.5. Moment during passive dorsiflexion trials within the stretch condition measured at 10%, 30%, 50%, 70% and 90% of ROM.
- Figure 3.4.6. Achilles tendon length (A) and gastrocnemius medialis (GM) muscle length (B) during maximal concentric plantarflexion trials measured at 50%, 70% and 90% of ROM.
- Figure 3.4.7. Achilles tendon (A) and gastrocnemius medialis (GM) muscle length (B) during passive dorsiflexion trials measured at 10%, 30%, 50%, 70% and 90% of ROM.
- Figure 4.3.1. Timeline of the maximal voluntary isometric contractions (MVICs) and stretch interventions.
- Figure 4.3.2. Active joint moment during a ramped isometric plantarflexion trial measured in the anatomical position (0°).
- Figure 4.4.1. Normalised isometric joint moment and electromyographic (EMG) amplitude during the 1st and 6th maximal voluntary isometric contraction (MVIC).
- Figure 4.4.2. Normalised moment during maximal concentric plantarflexion trials measured at 50%, 70% and 90% of ROM.
- Figure 4.4.3. Normalised triceps surae (TS) electromyographic (EMG) amplitude during maximal concentric plantarflexion trials measured at 50%, 70% and 90% of ROM.
- Figure 4.4.4. Triceps surae (TS) electromyographic (EMG):moment ratio during maximal concentric plantarflexion trials measured at 50%, 70% and 90% of ROM.
- Figure 4.4.5. Correlations between post-maximal isometric contractions (MVICs) reductions in concentric joint moment and triceps surae (TS) electromyographic (EMG) amplitude (A = 50%; B = 70%; C = 90% of ROM).
- Figure 4.4.6. Correlations between 30 min post-stretch recovery in concentric joint moment and triceps surae (TS) electromyographic (EMG) amplitude (A = 70%; B = 90% of ROM).
- Figure 4.4.7. Joint moment during passive trials measured at 50%, 70% and 90% of ROM.

- Figure 4.4.8. Achilles tendon length (A), gastrocnemius medialis (GM) muscle length (B) and Achilles tendon stiffness (C) during the 1st and 6th maximal voluntary isometric contraction (MVIC).
- Figure 4.4.9. Achilles tendon stiffness calculated during the concentric trials measured at 90% of ROM.
- Figure 4.4.10. Gastrocnemius medialis (GM) muscle (A) and Achilles tendon (B) length calculated during the passive trials measured at 50%, 70% and 90% of ROM.
- Figure 5.3.1. Timeline of the maximal voluntary concentric contractions (MVCCs) and stretch interventions.
- Figure 5.4.1. Normalised moment during maximal concentric plantarflexion trials measured at 50%, 70% and 90% of ROM.
- Figure 5.4.2. Normalised triceps surae (TS) electromyographic (EMG) amplitude during maximal concentric plantarflexion trials measured at 50%, 70% and 90% of ROM.
- Figure 5.4.3. Triceps surae (TS) electromyographic (EMG):moment ratio during maximal concentric plantarflexion trials measured at 50%, 70% and 90% of ROM..
- Figure 5.4.4. Correlations between post-maximal voluntary concentric contractions (MVCCs) reductions in concentric joint moment and triceps surae (TS) electromyographic (EMG) amplitude (A = 50%; B = 70%; C = 90% of ROM).
- Figure 5.4.5. Joint moment during passive trials measured at 50%, 70% and 90% of ROM.
- Figure 5.4.6. Achilles tendon length (A), gastrocnemius medialis (GM) muscle length (B) and Achilles tendon stiffness (C) calculated during the concentric trials measured at 50%, 70% and 90% of ROM.
- Figure 5.4.7. Achilles tendon length (A) and gastrocnemius medialis (GM) muscle length (B) during the passive trials measured at 50%, 70% and 90% of ROM.

Publications arising from the research

Published articles

Kay, A. D. & Blazevich, A. J. (2009). Moderate-duration static stretch reduces active and passive plantarflexor moment but not Achilles tendon stiffness or active muscle length. *Journal of Applied Physiology*, 106, 1249-1256.

Kay, A. D. & Blazevich, A. J. (2009). Isometric contractions reduce plantarflexor moment, Achilles tendon stiffness and neuromuscular activity but remove the subsequent effects of stretch. *Journal of Applied Physiology*, 107, 1181-1189.

Articles under review

Kay, A. D. & Blazevich, A. J. Concentric muscle contractions prior to static stretching minimise but do not remove stretch-induced force deficits. *Journal of Applied Physiology*, in press.

Presentations

Kay, A. D. & Blazevich, A. J. Isometric contractions reduce plantarflexor moment, Achilles tendon stiffness and neuromuscular activity but remove the subsequent effects of stretch. 5th annual conference of the United Kingdom Strength & Conditioning Association, Wyboston, United Kingdom, June 5-7, 2009.

Chapter 1

Introduction

1.1 Background to the thesis

Pre-performance or warm-up routines are normally performed prior to exercise and sporting participation to enhance force production and reduce the injury risk in clinical, recreationally active and athletic populations (Bishop, 2003). These routines regularly include cardiovascular work, progressively intense muscular contractions and muscle stretching. The acute effects of stretch include a temporarily increased functional range of motion (ROM) and reduced muscle-tendon complex (MTC) stiffness (Alter, 1996; Cramer et al., 2004, 2007; Kay & Blazevich, 2008), which potentially reduce injury risk, while the strong muscular contractions modify tendon stiffness (Kubo et al., 2001b) and possibly optimise force production (Baudry & Duchateau, 2007; Hamada et al. 2003; O'Leary et al., 1997). However, the efficacy of pre-performance stretching to reduce injury risk is equivocal, with several reviews of the literature failing to find sufficient evidence to support this contention (Gleim & McHugh, 1997; Thacker et al., 2004; Weldon & Hill, 2003). Furthermore, there is a growing body of research highlighting significant impairments in force and power production following acute static stretch in (amongst others) the knee extensors (Siatras et al., 2008), knee flexors (Ogura et al., 2007) and plantarflexors (Maisetti et al., 2007). Given the relative importance of the plantarflexors in many exercise and sporting situations including propulsion during locomotion, the present research focussed on this muscle group. An important consideration for the present research was not only to determine the effects of moderate-duration stretch on force production, but also to highlight the possible mechanisms underpinning these losses. Although several mechanisms have been hypothesised, the two primary mechanisms include: 1) a reduced neuromuscular activity, as measured by electromyographic (EMG) amplitude (Avela et al., 1999, 2004, Fowles et al., 2000), and 2) changes in the stiffness of MTC, which are thought to affect myofilament interaction and reduce force (Cramer et al., 2007; Kay & Blazevich, 2008; Weir et al., 2005). Although initially these two mechanisms appear distinct, Avela et al. (2004) suggested that reduced MTC stiffness may result in disfacilitation of group Ib muscle afferents influencing the activation of the α motoneuron pool, accordingly these mechanisms may be related. Unsurprisingly, the inclusion of passive stretching within warm-up regimes prior to the performance of tasks that require maximal force production has recently come under increased scrutiny.

In contrast to the possible negative effects of pre-performance stretching, the series' of intense muscular contractions also commonly performed in warm-up routines has sometimes been shown to enhance muscle force production (Baudry & Duchateau, 2007; Hamada et al. 2003; O'Leary et al., 1997), a phenomenon known as post-activation potentiation (PAP). This force enhancement is usually attributed to the preceding series of contractions resulting in a greater phosphorylation of myosin light chains, leading to a greater calcium sensitivity of the contractile proteins (Grange et al., 1993; Palmer & Moore, 1989) that subsequently results in an increase

in both peak force and rate of force development (Metzger et al., 1989). However, the benefit of these maximal contractions is still debated because of equivocal reports in the literature (Chiu et al., 2003; Gossen & Sale, 2000; Hrysomallis & Kidgell, 2001) regarding the force potentiating effect. Importantly, Chiu et al. (2003) reported that while a potentiating effect occurred in a highly trained athlete group, no effect was detected within a recreationally active group, indicating that the training status of the participants may influence the effect of these contractions on force production. Collectively, the research examining either the isolated effects of stretch or intense muscular contractions on force production has revealed both beneficial (contractions) and detrimental (stretch) outcomes. However, to date no study has specifically examined the effects on force production when maximal contractions precede passive stretch, thus the combined effects of these interventions are presently unknown.

Whilst understanding the combined effects of these interventions is important for the design of warm-up protocols for clinical and athletic populations, it also has important implications for experimental study design. Several stretch-based studies have included repeated maximal contractions in either the warm-up or during the experimental testing protocol (Bradley et al., 2007; Cramer et al., 2004, 2007; Egan et al., 2007; Maisetti et al., 2007), while others included a brief cardiovascular warm-up (Behm et al., 2004; Kay & Blazevich, 2008; McBride et al., 2007; Siatras et al., 2008; Young et al., 2006), or no warm-up (Evetovich et al., 2003; McHugh & Nesse, 2008; Ogura et al., 2007; Ryan et al., 2008; Weir et al., 2005), prior to examining the effects of stretch. The significant differences in study design may partially explain the disparate results reported in the literature on the effects of stretch, the mechanisms underpinning any reductions in force and the efficacy of stretching during warm-up routines prior to the execution of tasks where maximal force production is important to performance.

1.2 Aims of the thesis

The major aims of the thesis were to 1) determine whether a moderate duration of acute static stretch (3 min) would result in significant force deficits within the plantarflexors, 2) examine a number of potential mechanisms underpinning these potential force losses, and 3) examine whether the inclusion of intense muscular contractions prior to stretching mitigate or compound the effects of stretch on force production. The present body of research was conducted between February 2005 and July 2009 with the data being collected in the biomechanics laboratory at The University of Northampton. Twenty recreationally active participants (9 female, 11 male) volunteered and the same participants were used in each of the three studies within the thesis. The participants were free from any lower limb injury and refrained from flexibility training during the testing period. Ethical approval was sought and granted from the School of Health at The University of Northampton and the research was conducted in accordance with the Declaration of Helsinki. The analysis techniques employed within the thesis included 1) isokinetic dynamometry, which was used to record passive, isometric and concentric plantarflexor joint moment (muscle force) prior to and following acute static stretching, 2) simultaneous EMG monitoring of the gastrocnemius medialis (GM) and lateralis

(GL), soleus (Sol), and tibialis anterior (TA), 3) ultrasonography identifying GM-Achilles muscle-tendon junction (MTJ) excursion enabling muscle and tendon length, strain and stiffness to be calculated *in vivo*, and 4) real-time 3D motion analysis to record movement of the ankle during the experimental trials.

1.3 Limitations within the literature

There are several methodological issues that may limit the external validity of previous research findings to populations employing pre-performance stretching. First, the duration of stretch imposed in many of these studies does not accurately reflect normal pre-performance athletic practice, with some studies employing durations ranging between 10-60 minutes (Avela et al., 2001; Behm et al., 2001; Fowles et al., 2000; Kokkonen et al., 1998; Kubo et al., 2001a). Adding to this issue, a clear dose-response effect has been reported (Kay & Blazevich, 2008; Knudson & Noffal, 2005; Ogura et al., 2007; Ryan et al., 2008; Siatras et al., 2008; Young et al., 2006), where reductions in maximal force production increase with longer durations of stretch. Clearly, the dose-response relationship indicates that shorter duration stretches will produce lesser, possibly non-significant, changes in muscle force production. Second, the possible mechanical and physiological changes underpinning these force deficits have yet to be fully elucidated with conflicting mechanisms reported in the literature. Third, the temporal effects of stretch (i.e. force recovery) have rarely been documented with only a few studies examining this issue; although Avela et al. (2001) and Fowles et al. (2000) reported force losses immediately post-stretch, force production returned to normal after 30 min of passive rest, indicating that the effect of stretch on force is transient. Finally, much of the research has examined the effects of stretch in isolation, despite warm-up practices involving the use of multi-intervention routines including cardiovascular work and intense muscular contractions, which have been reported to enhance muscle force production (Baudry & Duchateau, 2007; Hamada et al. 2003; O'Leary et al., 1997). Therefore, examining the effects of stretch in isolation potentially reduces external validity of the research findings, which may limit their contribution to our understanding of the impact of pre-performance exercises on muscle performance.

1.4 Overview of the thesis

In the following chapter (Chapter 2), a review of the literature examines in detail the major themes of the thesis, identifying current issues, misconceptions and limitations within the literature. In Chapter 3, the effects of an acute bout of moderate duration (3 min) static stretch on passive and active concentric plantarflexor moment at a range of joint angles is examined both immediately and 30 min after stretch. A number of potential mechanical and neuromuscular mechanisms underpinning any reductions in joint moment are also examined. In Chapter 4, the effects of a series of isometric contractions on the above measures and how their inclusion affects the subsequent impact of a bout of static stretch is examined. In Chapter 5, whether the mode of contraction during the intervention (isometric vs. concentric) influences the subsequent effects of stretch is examined. Finally, in Chapter 6, a general discussion of the

major findings of thesis is provided, which identifies any limitations within the present body of research, and suggests possible directions for future research.

Chapter 2

Literature Review

2.1 Introduction

It is well documented that both athletic performance and injury risk can be altered by the performance of a complete pre-performance routine (i.e. a warm-up) prior to intense physical work (Agre, 1985; Alter, 1996; Bishop, 2003; Woods et al., 2007). Acute stretching is a regular part of these warm-up routines, which can temporarily increase functional ROM and reduce MTC stiffness (Alter, 1996; Cramer et al., 2004, 2007; Kay & Blazevich, 2008). Its inclusion within a pre-performance routine is based upon the premise that flexibility, the range of motion (ROM) at or about a joint or series of joints (Alter, 1996) is an important aspect within the aetiology of musculotendinous strain injury. However, given that multi-intervention warm-up protocols are commonly employed including cardiovascular work, intense muscular contractions and muscle stretching, the specific element responsible for these effects is difficult to ascertain. This issue has been raised in several reviews of the literature (Gleim & McHugh, 1997; Thacker et al., 2004; Weldon & Hill, 2003; Witvrouw et al., 2004), which report equivocal support for stretching as a preventative tool for injury risk.

Recently, numerous articles have reported that acute static stretch can induce significant decrements in force and power production (Avela et al., 1999, 2004; Behm et al., 2001; Brandenburg, 2006; Cornwell et al., 2002; Cramer et al., 2004, 2007; Fowles et al., 2000; Kay & Blazevich, 2008; Knudson & Noffal, 2005; Kokkonen et al., 1998; Maisetti et al., 2007; McHugh & Nesse, 2008; Nelson et al., 2001a, 2001b; Ogura et al., 2007; Siatras et al., 2008; Viale et al., 2007; Weir et al., 2005; Young et al., 2006). Given that mechanical and neuromuscular mechanisms have been implicated with losses in force, the purpose of this chapter is to: 1) explain neuromuscular activity, 2) describe the structure and function of MTC, 3) examine the mechanical properties of the MTC, 4) report the acute effects of both static stretch and muscular contractions on muscle performance, 5) examine possible mechanisms underpinning these losses, and 6) highlight areas that require further investigation and clarify the aims of the present research.

2.2. Neuromuscular parameters of force production

2.2.1. Neuromuscular hierarchy

The activation of muscle fibres to produce force is initiated from the motor cortex located within the frontal lobe, specifically within the precentral gyrus (Evarts, 1979); although there are other excitatory neurones in both the central and peripheral nervous systems that also activate the α -motoneurone pool to produce muscular force. The neurones within the motor cortex, known as pyramidal cells, possess axons that form the extrapyramidal tracts that descend down the spinal cord and synapse with alpha (α) motoneurones within the spinal cord (Evarts, 1979). The α -motoneurones descend into the periphery and synapse at the neuromuscular junction (NMJ)

with the muscle fibres of the relevant muscle. Muscle activation results in a motor-sensory feedback loop that can either enhance or diminish the activation of the α -motoneurone pool and ultimately affect force output (Avela et al., 2004). Both inhibitory and excitatory neurones synapse with the motoneurone at the spinal level (see Figure 2.2.1), and the combined input and interaction of these neurones dictate whether the threshold of the motoneurone is achieved and an action potential is transmitted along the neurone. Excitatory neurones from the motor cortex that activate α -motoneurones also activate gamma (γ) motoneurones of the intrafusal fibres (muscle spindle) of the same muscle. This results in a sensory feedback loop with neurones from the muscle spindle (Type Ia and II muscle afferents) sending excitatory impulses to the α -motoneurone pool, enhancing the activity of motor units (Alter, 1996). Paradoxically, when large forces are generated within the muscle, the resultant strain of the tendon can activate golgi tendon organs (Type Ib muscle afferents), located in the aponeurosis or muscle-tendon junction, which send inhibitory impulses to the α -motoneurone pool, decreasing the overall stimulus to the motor units. Similarly, inhibitory impulses can also be initiated from type III & IV afferents, reducing the overall activation of the α -motoneurone pool. Collectively, any changes to the firing patterns of any of the stimulatory or inhibitory neurones associated with the α -motoneurone pool will change the overall recruitment and resultant force produced (Cifrek et al., 2009).

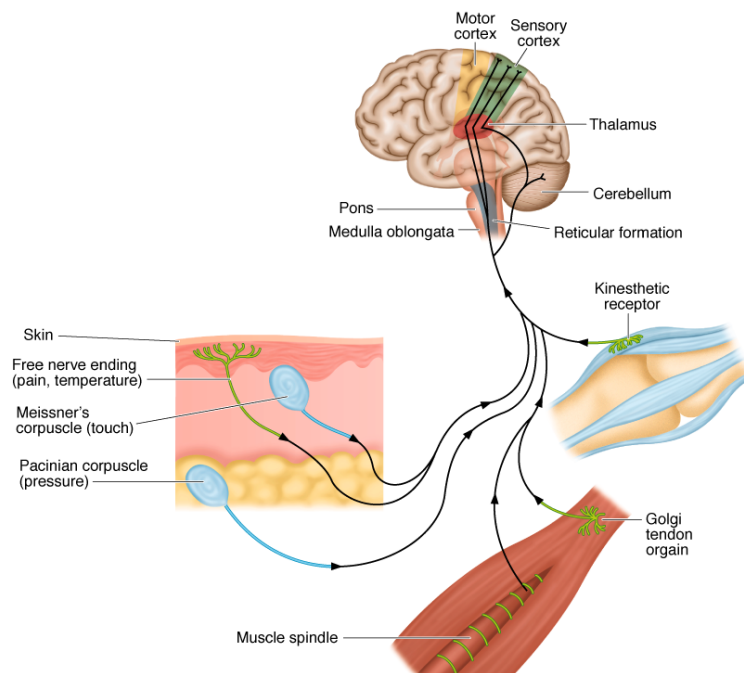

Figure 2.2.1. Excitatory and inhibitory neuromuscular input (from Wilmore & Costill, 1999).

2.2.2. Neuromuscular activity

Muscle fibres are recruited according to the all or none principle, where an action potential is transmitted through the motoneurone to all its associated muscle fibres (Henneman et al., 1979). Each fibre will synchronously twitch or enter a state of tetanus (contraction) if a continuous train of impulses is delivered. However, no fibre within a motor unit will contract if their associated neurone does not deliver an action potential. Therefore, the development of muscular force is dictated by the number of muscle fibres recruited, with greater muscular force being associated with a larger number of fibres activated (Henneman et al., 1979). This recruitment is rank ordered through the motor unit threshold hierarchy displayed in the principle of orderly recruitment (see Figure 2.2.2). A motor unit is the functional unit of the neuromuscular system comprising of an α -motoneurone and its associated muscle fibres. Each neurone within the α -motoneurone pool of a specific muscle has a distinct threshold where a specific strength of stimulus from the motor cortex is required to activate each neurone, which subsequently, due to the all or none law, dictates the number of muscle fibres recruited and the resultant force produced (Henneman et al., 1979). In addition to the number of motor units recruited, the rate coding of the impulses that activate the muscle fibres can also dictate force production (Morimoto & Masuda, 1984). Therefore the combination of total motor unit recruitment and the rate of recruitment can influence the intensity of muscular contraction and force production.

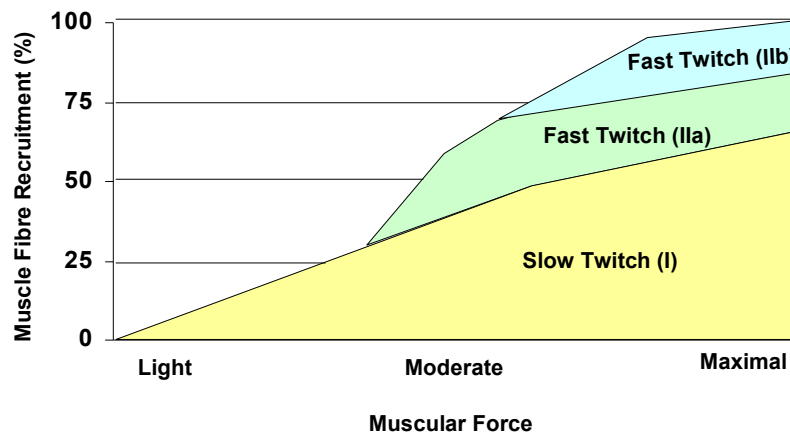

Figure 2.2.2. Principle of orderly recruitment.

Neuromuscular activity can be measured using electromyography (EMG), which is somewhat reflective of the contractile state of the muscle (Cifrek et al., 2009). The amplitude of the EMG signal is purported to be indicative of the total motor unit activity, while the frequency content (mean & median) is indicative of the conduction velocity of the muscle fibres (described in detail later; see 2.8.2). Changes to the descending neural drive from the motor cortex, or from peripheral reflex loops from the associated muscle afferents following interventions, could alter the activity of the α -motoneurone pool and ultimately affect force potential (Avela et al., 2004; Cramer et al., 2004). Therefore analysis of the EMG activity during contraction may reveal

whether reduced neuromuscular activity is a mechanism associated with post-stretch force-losses.

2.2.3. Excitation-contraction coupling

Following the activation of an α -motoneurone, action potential or nerve impulse propagation is generated along the neural membrane to the neuromuscular junction (NMJ). Following the arrival of the action potential at the NMJ, several processes involved with the excitation-contraction coupling process and sliding filament theory occur. Voltage-sensitive calcium (Ca^{2+}) channels to open allowing Ca^{2+} to enter the neural cell membrane, which results in synaptic vesicles containing neurotransmitters (acetylcholine) to fuse with the cell membrane, diffusing acetylcholine into the synaptic cleft of the NMJ by exocytosis (see Figure 2.2.3). Acetylcholine then binds with receptors on the motor end plate of the sarcolemma of the muscle fibre, which activates sodium gates on the sarcolemma. This generates a wave of depolarisation along the sarcolemma and down the t-tubule network where it is detected by voltage sensitive dihydropyridine (DHP) and ryanodine (RYR) located in the sarcoplasmic reticulum (SR). This initiates the release of Ca^{2+} from the SR into the sarcoplasm (for a review see Meissner & Lu, 1995), which binds to the protein troponin. The affinity troponin has for Ca^{2+} results in troponin pulling the tropomyosin filament from the actin filament unblocking the active binding site on the actin filament enabling actin-myosin cross-bridge interaction, as per the sliding filament theory to produce force (Huxley, 1967). However, interventions which induce substantial strain to the muscle may affect force production by impacting the structures and processes involved with the excitation-contraction coupling process including the sarcoplasmic reticulum (Bruton et al., 1996; Lamb et al., 1995), transverse-tubular network (Yeung et al., 2002), Ca^{2+} release (Armstrong et al., 1993) and myosin light chain sensitivity to Ca^{2+} (Grange et al., 1993; O'Leary et al., 1997) (described later; see 2.7.4).

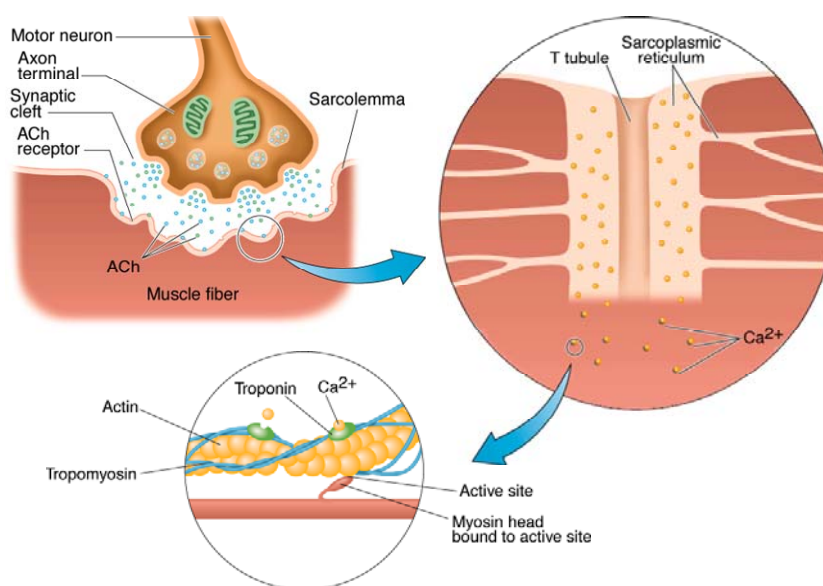

Figure 2.2.3. Calcium release following an action potential (from Wilmore & Costill, 1999).

2.3 Anatomy of the muscle-tendon complex

2.3.1 Muscle structure

Although the muscle-tendon complex (MTC) acts as a single functional unit that generates force to produce and control movement, its gross structure can be separated into the muscle belly and the tendons or aponeuroses connecting the muscle to the bone. Skeletal muscle is a hierarchical composite structure of contractile protein filaments and viscoelastic connective tissue (Fukanaga et al., 1997). The connective tissue, or muscle fascia, can be separated into the epimysium surrounding the entire muscle belly, the perimysium encompassing bundles of muscle fibres (fascicles), and the endomysium, which surrounds each individual muscle fibre or cell (see Figure 2.3.1).

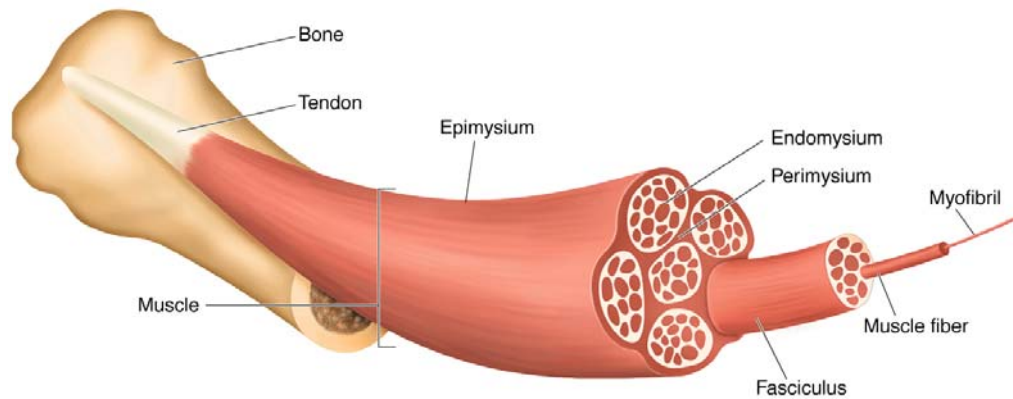

Figure 2.3.1. Muscle hierarchical structure (from Wilmore & Costill, 1999).

The muscle cell, or fibre, also comprises a hierarchical structure with a plasma membrane (sarcolemma) surrounding the cell, sub-units termed myofibrils that contain several protein filaments including actin, myosin, titin, troponin and tropomyosin. These myofilaments are arranged in a functional unit termed the sarcomere (see Figure 2.3.2), which can be measured from Z disk to Z disk, sarcomeres run in series through the whole length of the muscle cell.

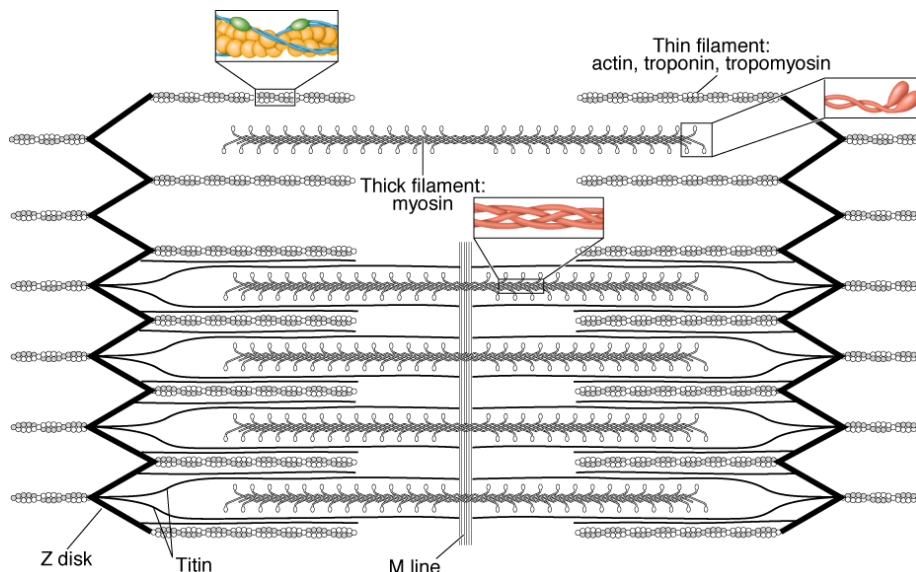

Figure 2.3.2. Myofilament arrangement of the sarcomere (from Wilmore & Costill, 1999).

The myofilaments actin and myosin interact with one another via cross-bridges activated during muscular contraction to develop tension transmitted through the muscle into the tendon onto the bone to produce movement. As depicted in Figure 2.3.2, myosin lies central to the Z-discs of the sarcomere and is secured in this position by the large extensible protein titin, while actin is attached to the Z-discs of one half of the sarcomere and is structurally supported by nebulin (Wang et al., 1993). The myofilaments are arranged in a hexagonal pattern (see Figure 2.3.3) enabling each actin filament to interact with three myosin filaments and each myosin filament able to interact with approximately six actin filaments (Nistal et al., 1977). The myofibrils in the muscle fibre are interconnected via the network of M bridges (myomesin) and Z-discs, which are attached to adjacent parallel myofibrils through intermediate filaments (desmin, vimentin and synemin). These are subsequently attached to the cytoskeleton of the muscle cell via costameres (Campbell & Stull, 2003; Ervasti, 2003). The cross-sectional structural arrangement of the Z- and M-lines in the sarcomere to the cytoskeleton of the muscle cell is thought to be responsible for lateral force transmissions (for a review see Bloch & Gonzalez-Serratos, 2003). Increases in muscle force occur when a greater number of motor units are recruited, which results in more actin-myosin interaction, additionally the number of available cross-bridges that can produce force is also dictated by sarcomere length, or muscle length. In opposition, any disruption to the cytoskeleton or filament arrangement within the cell either serially or laterally induced by tensile loading from either stretch or contractions could disrupt the transfer of muscular force to the tendon and attenuate force accordingly.

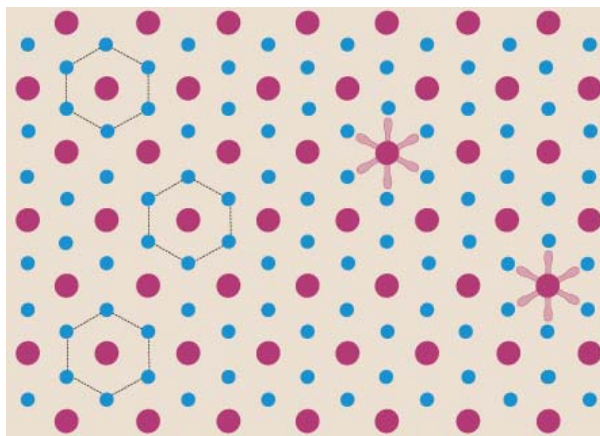

Figure 2.3.3. Cross-sectional hexagonal actin-myosin arrangement (from McArdle et al., 2001).

2.3.2. Plantarflexor anatomy

The focus of the present thesis is on the force production within the plantarflexors. Several muscles contribute to plantarflexor joint moment including the soleus, gastrocnemius medialis and lateralis, plantaris, tibialis posterior, peroneus longus and brevis and flexor digitorum longus (Shier et al., 2002). The architectural structure of these muscle vary (pennation angle, tendon length), resulting in some muscles (gastrocnemius lateralis) having longer fibres and a greater number of sarcomeres in series than others (gastrocnemius medialis, soleus). These

differences can affect the force generating capacity of the muscles and may also influence the degree that muscle stretching or contractions may compromise force production. Although several muscles contribute to plantarflexion, the triceps surae (soleus and gastrocnemii muscles) connected to the calcaneal tuberosity via the Achilles tendon, have been estimated to account for between 72% (Murray et al., 1976) and 93% (Giddings et al., 2000) of plantarflexion joint moment, clearly indicating its relative importance to the plantarflexor joint moment. During sporting and/or exercise tasks, muscles absorb and produce force. However, during locomotion the plantarflexors are of greater importance to propulsion than absorption, with positive work accounting for more than double the negative (McClay & Manam, 1999), suggesting a much greater concentric than eccentric demand (Czerniecki et al., 1991; Winter, 1983). Therefore, the priority of the plantarflexors is in delivering propulsive locomotor drive during gait rather than absorbing impact forces, a role predominantly undertaken by the knee extensors (Czerniecki et al., 1991; Winter, 1983). As such, understanding the impact of interventions that alter concentric force production is of great importance.

2.3.3. Tendon structure

The triceps surae muscle group transfer force to the calcaneum via the Achilles or calcaneal tendon. Tendons are a composite network of collagenous (30%) and elastic (2%) materials, embedded in a ground substance of glycoproteins, proteoglycans, and water (68%) (Vogel, 2003). The hierarchical structure of tendinous tissue is similar to that of muscle with several connective sheaths surrounding distinct levels of the tendon. Some tendons, including the Achilles tendon, have an extra connective sheath: the paratendon, which contains fluid to minimise friction between the tendon and surrounding tissues. The tendon is then compartmentalised (see Figure 2.3.4) into fascicles, surrounded by the fascicular membrane, fibrils, subfibrils and microfibrils formed from a triple helix of three polypeptide chains forming the structural unit of tendon called tropocollagen (O'Brien, 1997). This structure gives rise to several important mechanical properties (described later; see section 2.4), which can influence the production of force within the MTC. Any changes to these properties induced by tensile loading from either stretch or contractions could alter these properties and influence force transmission.

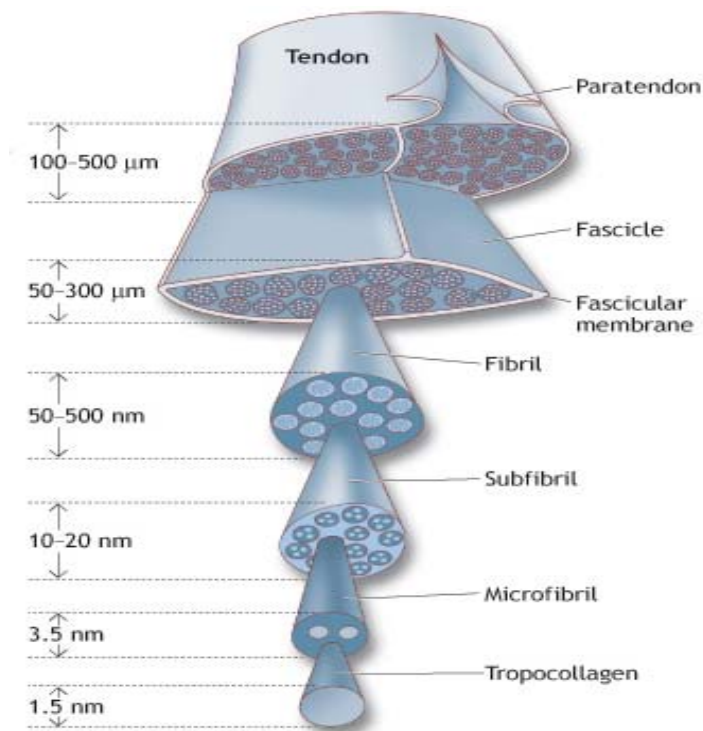

Figure 2.3.4. Hierarchical structure of the tendon (from McArdle et al., 2001).

2.4. Mechanics of the muscle-tendon complex

Although anatomically distinct, the muscle and tendon interact in series to form a functional unit termed the muscle-tendon complex (MTC). Some of the mechanical properties of the MTC include extensibility, elasticity, plasticity and viscosity. In addition, the muscle also possesses an additional property, contractility, or the ability to shorten below resting length, achieved through myofilament interaction (see 2.3.2). These properties are attributable to specific structures within the MTC, which can be categorised as the: 1) contractile component (CC), 2) parallel elastic component (PEC), 3) series elastic component (SEC), and 4) viscous component (VC) (McNair & Stanley, 1996). Depicted in a mechanical schematic of the MTC below (see Figure 2.4.1), CC represents the myofilament interaction between actin and myosin protein strands, which enables the shortening of the muscle tissue to produce force. The PEC or muscle fascia (perimysium, epimysium, and endomysium) runs parallel to the contractile component and represents the elasticity of the connective tissues (Enoka, 1994). The SEC also represents the elastic properties of the tendon and aponeurosis, while the viscous properties relate to the ground substance that supports the collagenous tissue represented by the damping pots (McNair & Stanley, 1996). The primary role of the MTC is to generate force and these specific components possess unique properties that contribute differently to active and passive force production within the MTC. Acute interventions, like stretching or intense muscular contractions, may modify the properties within these tissues, and performance may be affected by altering the fine dynamic balance of mechanical and neurophysiological factors that dictate force production and muscle function (Fowles et al., 2000). Therefore, an appreciation of how the MTC produces force is required to provide an understanding and appreciation of these mechanisms (described in detail later).

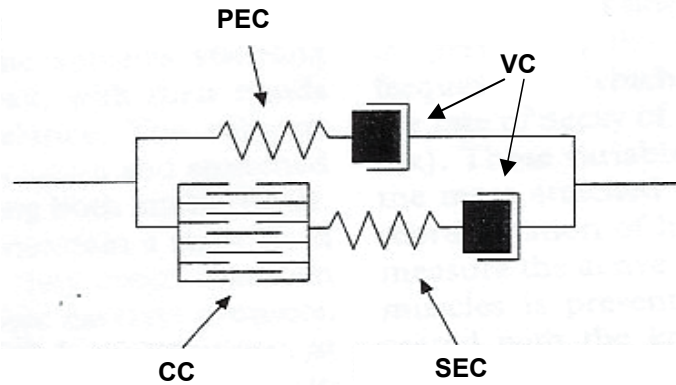

Figure 2.4.1. Mechanical schematic of the muscle-tendon complex (MTC) (from McNair & Stanley, 1996).

2.5. Biomechanical parameters of force production

2.5.1 Active force-length characteristics of skeletal muscle

One factor affecting active force production during a given level of muscle activation is the degree of myofilament overlap, as this determines cross-bridge availability (McComas, 1996). The force-length characteristics of skeletal muscle are non-linear where there is an optimal length for skeletal muscle to produce force (plateau region), and both shorter or longer 'suboptimal' lengths, termed the ascending and descending limbs, respectively (see Figure 2.5.1). When the muscle is activated in a lengthened state, minimal myofilament overlap exists reducing cross-bridge availability and attenuating active force accordingly. Shorter muscle length increases myofilament overlap and available cross-bridge interaction enabling greater force production until optimal overlap is reached. However, further shortening of the sarcomere decreases force output despite similar cross-bridge availability; attributed to folding of the actin filament where actin abuts against the Z-disc interfering with the binding of cross-bridges (for a review see Rassier et al., 1999). Furthermore, calcium sensitivity of the contractile apparatus is diminished with reduced muscle length (Iazzio, 1990), which would slow the excitation-contraction coupling process. As such, it is evident that the operating length of the muscle during contraction, and the subsequent level of interaction of actin and myosin, may influence the magnitude of force production. Importantly, the plantarflexors tend to operate on the ascending limb of their force-length curve during most normal movements (Maganaris, 2001, 2003), so any intervention which causes the muscle to operate at a shorter length would also decrease muscle force potential.

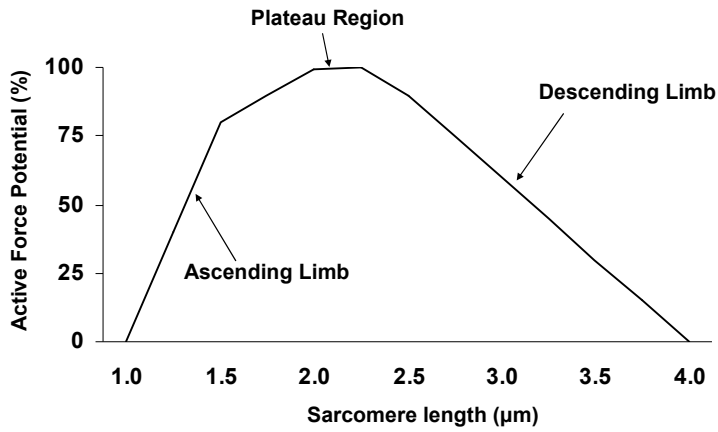

Figure 2.5.1. Active force-length characteristics of skeletal muscle.

2.5.2. Passive force-length characteristics of the MTC

Passive force-length characteristics of the MTC are apparent in the stress-strain curve of the tissues, while biological tissues deform under a given load or force (Nubar, 1962), however, a clear distinction between force-length and stress-strain characteristics is required. The force-length characteristics are calculated by measuring the force applied and the resultant elongation of the tissue. Although similar, stress is calculated as the force divided by the cross-sectional area of the tissue, and strain is the length change divided by the original length of the tissue (Nubar, 1962). The elastic or Young's modulus is determined by the stress-strain ratio where a stiffer tissue will deform to a lesser extent than a more compliant tissue and as a result, will display a steeper slope on a stress-strain plot (see Figure 2.5.2). The cross-sectional area of a tendon is non-uniform and the stress placed through the tendon will vary according to the area of the tendon along its length, which may impact upon the strain experienced and the calculation of stiffness. When examining the tendon *in vivo* as a functional unit rather than a specific area of the tendon, following an acute intervention (e.g. stretching) under repeated measures conditions, calculating the stiffness of the tendon by force-length changes may be more appropriate as this is reflective of the tendon as a functional unit.

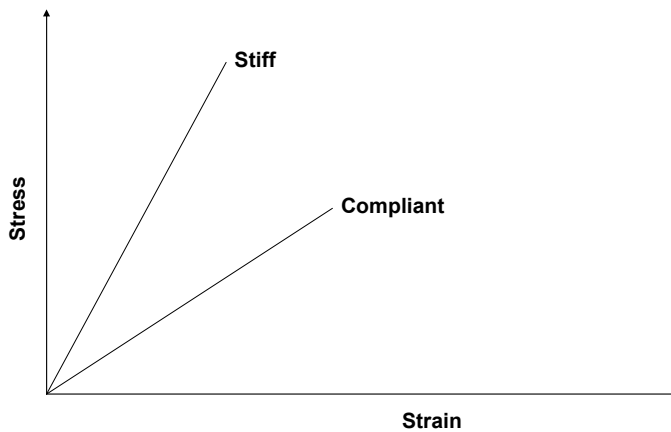

Figure 2.5.2. Stiff & compliant stress-strain characteristics of an elastic material.

During passive elongation of a MTC, the resistive force produced by the tissues can be measured using isokinetic dynamometry. Tissues commonly display a curvilinear force-length response with the tissues initially at a slack length entering the 'toe region', which accounts for the initial curvilinear nature of the force-length curve (Magnusson et al., 1996b; Morse et al., 2008). Following this a further increase in the length of the tissues produces a proportional increase in force (linear region), which continues until the force placed through the tissues breaches the tissue's mechanical loading limit and the tissue ruptures (see Figure 2.5.3).

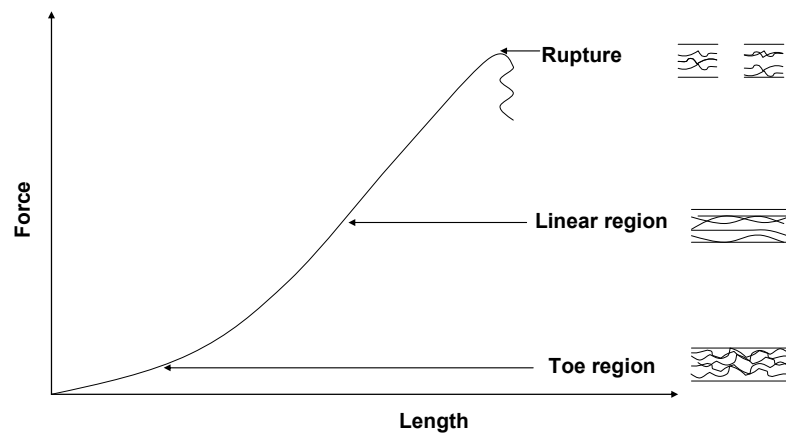

Figure 2.5.3. Passive force-length characteristics of the muscle-tendon complex (MTC).

The primary roles of the tendon are to efficiently transmit muscular force to the bone during isometric and concentric contractions but also to store and release energy during eccentric-concentric muscle actions (Wilson et al., 1994). The stiffness of the MTC has important functional implications for these roles as this has been significantly correlated with isometric and concentric force (Wilson et al., 1994) and with running economy as there was an inverse correlation with aerobic demand (Craib et al., 1996; Gleim et al., 1990; McMahon et al., 1987). A reduction in tendon stiffness may increase neuromechanical delay (Cresswell et al., 1995; Grosset et al., 2009; Kubo et al., 2000), reduce the rate of force development (Bojsen-Møller et al., 2005; Edman & Josephson, 2007; Kubo et al., 2001b) and decrease the active muscle length (Kubo et al., 2001b); a reduction in muscle length of the plantarflexors would reduce force in accordance with its force-length relationship (Maganaris, 2001, 2003). While this has obvious performance implications, reducing tendon stiffness will increase energy storage in the tendon and reduce the rate of force loading into the muscle tissue during eccentric actions, thus decreasing the demands placed upon the muscle during eccentric action and possibly reducing the strain injury risk to the musculature (Hess, 1989). Therefore, the effects of interventions that modify the stiffness of the MTC on performance and injury may be variable.

2.6. Acute effects of stretch on the MTC

2.6.1. Introduction to pre-performance stretch

Athletes regularly include stretching regimes within their warm-up routines prior to performance under the premise that it provides a protective effect for musculotendinous injury, which may originate from the inverse correlation between musculotendinous injury risk and flexibility (Alter, 1996). While significant increases in functional range of motion (ROM) or flexibility can be achieved through acute static stretch, equivocal reports exist supporting any prophylactic benefit (Gleim & McHugh, 1997; Thacker et al., 2004; Weldon & Hill, 2003). Despite recent reports of significant impairments in muscle force production (Ogura et al., 2007; Maisetti et al., 2007; Siatras et al., 2008), pre-performance stretching continues to be regularly performed in clinical, experimental and athletic populations prior to the performance of intense physical work (Bishop, 2003; Woods et al., 2007). Accordingly, the following sections will examine the effects of static stretch on force production and the commonly hypothesised mechanical and neuromuscular mechanisms underpinning any reductions in force.

2.6.2. Effects of stretch on passive joint moment

Stretching regimes aim to increase functional ROM that can also alter the mechanical properties of the MTC. The slope of the passive joint moment is affected by the relative stiffness of the MTC, joint capsule and structures within the joint. Following an acute bout of static stretch (5-10 min), a significant reduction in passive joint moment has been reported, which is indicative of a reduction in the stiffness of these tissues (Kubo et al., 2001a; Magnusson et al., 1996c; Morse et al., 2008). However, equivocal data exist in studies employing shorter duration stretch (< 2 min) with some (Magnusson et al., 1998, 2000; Muir et al., 1999) but not others (Kay & Blazevich, 2008) reporting no change in passive moment. This prompted the authors (Magnusson et al., 1998, 2000; Muir et al., 1999) to attribute the increased ROM that succeeded the stretch to an increased 'stretch tolerance' rather than any change in the mechanical properties of the MTC. Collectively, these data indicate that while long duration stretch (> 5 min) consistently alters the mechanical properties of the MTC, as indicated by the reduced passive moment, the effects of moderate duration stretch (< 3 min), which would most typically be employed in pre-performance routines, are less clear. A second explanation for the findings is that research studies have reported passive joint moment measured at different joint angles. Muir et al. (1999) reported no change in passive moment post-stretch (2 min) when measured in the anatomical position (0°) and at 10° dorsiflexion, which would not place the plantarflexors in a highly stretched position. Recently, Kay & Blazevich (2008) measured the effects of stretch (60 s) at 20° dorsiflexion and found significant reductions in passive moment. Morse et al. (2008) measured the passive moment post-stretch (5 min) at 0°, 5°, 10°, 15°, 20° and 25° of dorsiflexion but only found a significant reduction in the passive moment at the largest joint angle (25°). However, a lack of change in the passive moment within the knee flexors has been reported at full ROM (Magnusson et al., 1998, 2000). Collectively, these studies highlight the importance of examining the effects of moderate-duration stretch (< 3 min)

on MTC mechanics (passive moment) at joint angles where the muscle-tendon complex is in a highly stretched position.

2.6.3. Relative tissue strain during stretch

Both the muscle fascicles and the tendon deform as overall elongation of the MTC occurs during passive stretch. However, tendons are intrinsically stiffer than relaxed muscle, which would suggest that the strain would be more apparent in the fascicles. Whilst in animal models, the compliance of rabbit soleus fascicles was four times greater than that of its tendon (Herbert & Crosbie, 1997), *in vivo* measurements using ultrasonography of human gastrocnemius muscle revealed that during passive stretch of the ankle joint only $27 \pm 9\%$ of total length change occurred in the fascicles (Herbert et al., 2002). This can be partly explained by the Achilles being approximately 10 times longer than the fascicles of the gastrocnemius (Alexander & Bennett-Clark, 1977), therefore, with the same level of tissue strain, the absolute level of elongation in the tendon is greater as the tendon is proportionally longer (Muramatsu et al., 2001). However, Kawakami et al. (1998) and Maganaris (2003) reported human gastrocnemius fascicle length change $\sim 40\%$ of total MTC length change. The disparity probably exists due to the differing methods employed to determine initial length of the MTC (Herbert et al., 2002). Regardless, although muscle fascicles undergo significantly greater tissue strain, tendon elongation is responsible for the majority of overall increase in MTC length in the triceps surae-Achilles complex. Given that the plantarflexors operate on the ascending limb of their force-length characteristics (Maganaris, 2001, 2003); an increase in tendon lengthening, and thus muscle shortening, may be an important mechanism for post-stretch active force losses if tendon mechanics are compromised by stretch. Kubo et al. (2001a) measured the stiffness of the Achilles tendon to determine the effects of 10 min of passive stretch. They revealed a significant reduction in passive moment and Achilles tendon stiffness, attributing the reduced passive moment to changes in tendon stiffness. However, their data may be problematic as tendon stiffness was measured at the aponeurosis-fascicle junction rather than at the muscle tendon junction, so muscle stiffness changes may have influenced the results. Morse et al. (2008) showed that 5 min of plantarflexor stretch also reduced passive moment while Achilles tendon stiffness remained unchanged (measured at the muscle tendon junction); they attributed the reduction to changes in GM muscle stiffness. Therefore, further clarification of the effects of passive stretch on tendon mechanics is required, especially following shorter duration stretch (< 3 min), which is commonly used pre-performance as changes to the stiffness of the tendon may impact active force production (described later).

Identifying the specific tissues within the MTC associated with the stretch-induced reductions in passive joint moment may be important as this may highlight possible mechanisms underpinning the reductions in active force production. However, few studies examining the effects of stretch on passive joint moment have sought to identify the specific tissues (tendon or muscle) in which changes occurred. Given the relative paucity of literature and equivocal reports, the effects of stretch on tissue mechanics and the exact location of any effect remain

unclear. Therefore, examining the effects of stretch on the passive mechanics of the muscle and tendon, in addition to examining the effect to active force production, is important as this may enable the identification of possible mechanisms underpinning post-stretch reductions in active joint moment (force production).

2.7. Effects of stretch on active force production

2.7.1. Introduction to active post-stretch force losses

Although several reports (Kay & Blazevich, 2008; Kubo et al., 2001a; Morse et al., 2008) highlight significant reductions in plantarflexor passive moment in response to stretch, limited data exist identifying the location or specific tissues affected within the MTC responsible for this reduction. As the MTC is stretched, both muscle tissues (perimysium and cytoskeletal network; Gajdosik, 2001) and tendinous tissues (collagenous structures; Kirkendall & Garrett, 1997) are deformed. The changes in MTC mechanical properties have resulted in several authors (Avela et al., 1999, 2004; Fowles et al., 2000; Kay & Blazevich, 2008; Weir et al., 2005) hypothesising such changes impacting upon active force production. Therefore, the following sections will review the effects of passive stretch on active force production and the hypothesised physiological, mechanical and neuromuscular mechanisms underpinning these losses.

2.7.2. Implications of warm-up to reductions in active force

A growing body of research has highlighted the significant decrements in force and power production after acute passive stretching (Avela et al., 1999, 2004; Behm et al., 2001; Brandenburg, 2006; Cornwell et al., 2002; Cramer et al., 2004, 2007; Evetovich et al., 2003; Fowles et al., 2000; Kay & Blazevich, 2008; Knudson & Noffal, 2005; Kokkonen et al., 1998; Maisetti et al., 2007; McHugh & Nesse, 2008; Nelson et al., 2001a, 2001b; Ogura et al., 2007; Siatras et al., 2008; Viale et al., 2007; Weir et al., 2005; Young et al., 2006). However, a lack of reduction in force has also been reported (Behm et al., 2004; Cramer et al., 2006; Egan et al., 2006; Ryan et al., 2008; Yamaguchi et al., 2006). The equivocal findings may be attributable to differences in experimental study design, including the stretch duration imposed, the contraction mode employed, the muscle group examined, and whether an intense warm-up preceded the stretch intervention. The majority of studies identified in Table 2.7.1 report force deficits (92%) when an intense warm-up regime does not precede the stretch. However, this percentage declines to 57% when stretching is performed after a warm-up (see Table 2.7.2) and declines further to 50% when the warm-up includes repeated maximal contractions. Therefore, warm-up, particularly when intense contractions are utilised, may influence the post-stretch reduction in force, although other parameters (muscle group, stretch-duration) may also influence these results.

Table 2.7.1. Effects of passive stretch on muscular performance without prior warm-up

Authors	Warm-up	Muscle group/s	Total stretch duration	Major findings
Avela et al. (1999)	No	Plantarflexors	22.5 min (5400 × 250 ms)	Significant decrease in isometric plantarflexor MVC (23.2%) & EMG (19.9%)
Cornwell et al. (2002)	No	Gastrocnemius and Soleus	6 min (6 × 30 s per muscle)	Significant decrease in CMJ (4%) No change in EMG; No change in static jump height
Evetovich et al. (2003)	No	Biceps	6 min (4 × 30 s per stretch)	Significant decrease in concentric elbow flexor MVC at 30 & 270°s ⁻¹ ; No change in EMG
Fowles et al. (2000)	No	Soleus	30 min (13 × 135 s)	Significant decrease in isometric plantarflexor MVC (28%) & EMG
Kokkonen et al. (1998)	No	Quadriceps, hamstrings, plantarflexors	7.5 min (6 × 15 s per muscle)	Significant decrease in concentric knee flexor MVC (7.3%) & concentric knee extensor MVC (8.1%)
McHugh & Nesse (2008)	No	Hamstrings	6 min (6 × 60 s)	Significant decrease in isometric knee flexor MVC (17%)
Nelson et al. (2001a)	No	Quadriceps	8 min (8 × 30 s per stretch)	Significant decrease in isometric knee extensor MVC (7%) at 162°; No change in MVC at 90°, 108°, 126° & 144°
Nelson et al. (2001b)	No	Quadriceps	12 min (8 × 30 s)	Significant decrease in concentric knee extensor MVC at 1.05 (7.2%) & 1.57 rad·s ⁻¹ (4.5%); No change in MVC at faster velocities
Ogura et al. (2007)	No	Hamstrings	30 s and 60 s	Significant decrease in isometric knee flexor MVC (8.8%) after 60 s; No change in MVC after 30 s
Rosenbaum & Henning (1995)	No	Plantarflexors	3 min (3 × 30 s per stretch)	Significant decrease in reflex induced force (5%) & EMG (16%)
Ryan et al. (2008)	No	Plantarflexors	2, 4 & 8 min (30 s per stretch)	No change in isometric plantarflexor MVC or EMG compared to control condition
Weir et al. (2005)	No	Soleus	10 min (5 × 120 s)	Significant decrease in isometric plantarflexor MVC (7.1%) & passive torque (27%)
Yamaguchi et al. (2006)	No	Quadriceps	20 min (4 × 30 s per stretch)	Significant decrease in concentric peak power leg extension; No change in peak concentric MVC

Table 2.7.2. Effects of passive stretch on muscular performance with prior warm-up

Authors	Warm-up	Muscle group/s	Total stretch duration	Major findings
Behm et al. (2001)	5 min cycle	Quadriceps	3.75 min (5 × 45 s)	Significant decrease in isometric knee extensor MVC (12%) & EMG (20%)
Behm et al. (2004)	5 min cycle	Quadriceps, hamstrings, plantarflexors	9 min (3 × 45 s per muscle)	No change in isometric leg extensor MVC
Bradley et al. (2007)	5 min cycle, 6 maximal efforts	Quadriceps, hamstrings, plantarflexors	10 min (4 × 30 s per muscle)	Significant decrease in vertical jump (4%)
Cramer et al. (2004)	5 min cycle, 3 submax and max contractions	Quadriceps	8 min (4 × 30 s per stretch)	Significant decrease in concentric knee extensor MVC at 60°s ⁻¹ (3.3%); No change compared to control
Cramer et al. (2005)	5 min cycle, 3 submax and max contractions	Quadriceps	8 min (4 × 30 s per stretch)	Significant decrease in concentric knee extensor MVC (3.3%); No change compared to control
Cramer et al. (2006)	5 min cycle, 3 submax and max contractions	Quadriceps	8 min (4 × 30 s per stretch)	No change in eccentric knee extensor MVC
Cramer et al. (2007)	5 min cycle, 3 submax and max contractions	Quadriceps	8 min (4 × 30 s per stretch)	Significant decrease in concentric knee extensor MVC (3%) & EMG (11%)
Egan et al. (2006)	5 min cycle, 3 submax and max contractions	Quadriceps	8 min (4 × 30 s per stretch)	No change in concentric knee extensor MVC
Kay & Blazevich (2008)	5 min treadmill	Plantarflexors	Various (5 s, 15 s, 4 × 5 s, 4 × 15 s)	Significant decrease in isometric plantarflexor MVC (16.7%) after 4 × 15 s, No change in EMG
Maisetti et al. (2007)	Submax and 3 max contractions	Plantarflexors	75 s (5 × 15 s)	Significant decrease in (10%) isometric plantarflexor MVC No change in RFD; Significant decrease in (17%) passive moment
McBride et al. (2007)	5 min cycle	Quadriceps	1.75 min (3 × 35 s)	Significant decrease in isometric leg extension (5.6%); no change in EMG
Siatras et al. (2008)	5 min cycle	Quadriceps	Various (10, 20, 30 & 60 s)	Significant decrease in isometric (30 s - 8.5%; 60 s - 16%) and concentric knee extensor MVC (30 s - 5.5%; 60 s - 11.6%) at 60°s ⁻¹
Viale et al. (2007)	5 min cycle, 3 submax and max contractions	Quadriceps	6.5 min (9 × 45 s)	Significant decrease in (8%) isometric knee extensor MVC
Young et al. (2006)	5 min treadmill	Plantarflexors	1, 2, 4 min (30 s per stretch)	No change in concentric plantarflexor MVC or RFD

2.7.3. Dose-response effect of passive stretch

In addition to the warm-up preceding stretch, another issue affecting external validity is the extensive stretch durations (10-60 min) used in many studies, which do not reflect the durations of stretch commonly employed by athletes prior to performance. However, these durations cause large reductions in force, which enables researchers to study the mechanisms underpinning these losses. When short duration stretches (<2 min) are applied, equivocal findings have been reported with no reductions found in isometric (Behm et al., 2004) or eccentric knee extensor moment (Cramer et al., 2006), while significant reductions were detected in isometric plantarflexor moment (Kay & Blazevich, 2008). Interestingly, a dose-response effect of stretch on passive mechanics (as measured by joint moment) has already been reported (see section 2.5.2) where shorter duration stretches (<2 min; Magnusson et al., 1998, 2000; Muir et al., 1999) revealed no change in passive moment, while longer duration stretches (>5 min; Kubo et al., 2001a; Magnusson et al., 1996c; Morse et al., 2008) consistently reveal significant reductions. Similarly, several recent studies (Kay & Blazevich, 2008; Knudson & Noffal, 2005; Ogura et al., 2007; Ryan et al., 2008; Siatras et al., 2008; Young et al., 2006) specifically examined the dose-response effect of stretch on active force production and revealed a clear effect where reductions in maximal force become greater with longer stretch durations. The apparent dose-response effect for both passive and active force production may implicate altered mechanical properties of the MTC (tendon stiffness, muscle operating length) with the reductions in active force production. However, no study reporting significant reductions in active force has examined these variables, although several studies have implied these mechanisms underpinning losses in force, especially in the absence of any change to neuromuscular activity (Evetovich et al., 2003; Kay & Blazevich, 2008; Weir et al., 2005).

2.7.4. Neuromuscular mechanisms of post-stretch force losses

Whilst reductions in force and power production have obvious performance and injury implications (Hess, 1989), the mechanisms underpinning these losses are not fully understood. The two primary mechanisms implicated with stretch-induced force losses include: 1) a reduced neuromuscular activity (Avela et al., 1999, 2004, Fowles et al., 2000) and 2) changes in the mechanical properties of the MTC affecting muscle operating length (Cramer et al., 2004, 2007; Fowles et al., 2000; Kay & Blazevich, 2008; Nelson et al., 2001a, 2001b, Weir et al., 2005). Several authors have reported concurrent reductions in EMG and joint moment (Avela et al., 1999, 2004, Fowles et al., 2000), with Avela et al. (1999) also reporting no change in the EMG:moment ratio leading the authors to conclude that reduced neuromuscular activity (EMG) was responsible for the reductions in joint moment. The reduction in EMG amplitude is assumed to be reflective of an inability to activate the α -motoneurone pool, which will compromise motor unit activity and active force production accordingly. However, although several studies have reported concomitant reductions in EMG and moment, to the author's knowledge, no study to date has calculated the strength of any relationship between post-stretch reductions in moment and EMG to determine its relative importance to the reduction in force.

Although significant post-stretch reductions in moment and EMG have been reported, the specific mechanism underpinning the reduction in muscle activity is unclear. Cramer et al. (2004, 2005) reported significant reductions in moment and EMG in both the control and experimental limbs following 2 min of passive stretch, concluding that central mechanisms within the motor cortex inhibited descending neural drive and activation of the α -motoneurone pool. Alternatively, Avela et al. (1999) suggested that there was a peripheral component; either disfacilitation of the α -motoneurone pool from reduced excitatory group Ia and group II muscle afferent output, or inhibition of the α -motoneurone pool from increased inhibitory group Ib, III and IV muscle afferent output. Avela et al. (1999) reported a decline in Hoffmann (H)-reflexes post-stretch in conjunction with reduced passive moment and concluded that reduced muscle stiffness may have lowered the overall excitatory input to the α -motoneurone pool, reducing motor unit activity (as measured by EMG amplitude) and compromising joint moment. However, the authors did not employ sonography to determine which tissues (muscle or tendon) were responsible for the reduced passive moment. Therefore, the mechanism and location of any impairment to the neuromuscular system remains unclear.

2.7.5. Mechanical mechanisms of post-stretch force losses

The second mechanism commonly reported is a change in the mechanical properties of the MTC (Cramer et al., 2004, 2007; Fowles et al., 2000; Kay & Blazevich, 2008; Nelson et al., 2001a, 2001b, Weir et al., 2005) affecting force characteristics. Post-stretch reductions in both muscle (Morse et al., 2008) and tendon (Kubo et al., 2001a) stiffness during passive and active movements have been reported. The reduced muscle stiffness may impact structures associated with the excitation-contraction coupling process and compromise lateral and longitudinal active force transmission. Microtrauma within the cytoskeleton of the muscle fibre including the sarcoplasmic reticulum (Bruton et al., 1996; Lamb et al., 1995) or transverse-tubular disruption (Yeung et al., 2002) may affect the transmission of action potentials and subsequent calcium ion (Ca^{2+}) release from the lateral sacs of the sarcoplasmic reticulum, possibly affecting the excitation-contraction (EC) coupling process and attenuating force production. Changes in tendon stiffness may increase neuromechanical delay (Cresswell et al., 1995; Grosset et al., 2009; Kubo et al., 2000), reduce the rate of force development (Bojsen-Møller et al., 2005; Edman & Josephson, 2007; Kubo et al., 2001b) and decrease the active muscle length (Kubo et al., 2001b). The reduction in muscle length is functionally important in muscle such as the plantarflexors, which operate on the ascending limb of their force-length curve (Maganaris, 2001, 2003). Any decrease in tendon stiffness may result in sub-optimal myofilament overlap (Kay & Blazevich, 2008; Weir et al., 2005) compromising force production in accordance with skeletal muscle's force-length relationship (Maganaris, 2001, 2003).

These mechanical changes have been hypothesised because of the absence of any change in EMG activity while force declines post-stretch (Evetovich et al., 2003; Kay & Blazevich, 2008; Weir et al., 2005). This was further supported by Fowles et al. (2000) who reported that EMG fully recovered 10 min post-stretch while joint moment remained impaired 1 hour later, which is

clearly suggestive of other mechanisms impacting force production. Interestingly, while Kubo et al. (2001a) reported significant reductions in knee extensor tendon stiffness (2.3%) and significantly reduced muscle length following 10 min of static stretch, this was not accompanied by reduced isometric joint moment. In addition, Morse et al. (2008) reported that 5 min of static stretch resulted in no change to Achilles tendon stiffness and, to date, no studies have reported significant reductions in Achilles tendon stiffness and active force production post-stretch. Accordingly, the impact of stretch on the mechanical properties, neuromuscular activity and force generating capacity of the plantarflexors requires further examination.

2.8. Effects of intense contractions on force production

Pre-performance routines commonly include progressively intense, muscular contractions to condition the MTC and prepare the athlete for physical activity (Agre, 1985; Alter, 1996; Bishop, 2003; Woods et al., 2007). However, both beneficial (Baudry & Duchateau, 2007; Chiu et al., 2003; Gilbert & Lees, 2005; Hamada et al. 2003; O'Leary et al., 1997) and detrimental (Chiu et al., 2003; Gossen & Sale, 2000; Hrysomallis & Kidgell, 2001; Maganaris et al., 2006) effects on force production have been reported. Therefore, the following sections will review the effects of intense muscular contractions on active force production and the hypothesised physiological, mechanical and neuromuscular mechanisms underpinning the production of force.

2.8.1. Post-activation potentiation (PAP)

The performance of maximal contractions prior to the testing of peak muscle strength and power has been reported to enhance force production (Baudry & Duchateau, 2007; Chiu et al., 2003; Gilbert & Lees, 2005; Hamada et al. 2003; O'Leary et al., 1997), a phenomenon termed post-activation potentiation (PAP). The PAP force enhancement is suggested to originate from the phosphorylation of myosin light chains (Grange et al., 1993; O'Leary et al., 1997; Palmer & Moore, 1989), resulting in a greater rate of cross-bridge cycling due to an increased sensitivity of the contractile proteins to ionised Ca^{2+} . Although PAP has been shown to occur following electrically stimulated contractions (Abbate et al., 2000; Grange et al., 1993; MacIntosh & Willis, 2000), the effect following maximal voluntary contractions (MVC) is debated due to equivocal reports where some (Baudry & Duchateau, 2007; Chiu et al., 2003; Gilbert & Lees, 2005; Hamada et al. 2003; O'Leary et al., 1997) but not others (Chiu et al., 2003; Gossen & Sale, 2000; Hrysomallis & Kidgell, 2001) have detected this phenomenon. While differences in study design do not enable a direct comparison, the equivocal reports could be attributable to training status (Chiu et al., 2003), duration of contraction (Vandervoort et al., 1983) and recovery time post-contraction (Gossen & Sale, 2000). Therefore, for both pre-performance routines and experimental study design, careful consideration is required to ensure a fatiguing effect is not induced as this may be further compounded by the detrimental effects of a subsequent bout of stretch. In contrast, the potentiating effect may mitigate or remove the effects of stretch, a hypothesis that should be examined further to clarify the combined effects of these interventions on force production.

2.8.2. Contraction-induced fatigue

A common definition of fatigue is a decrease in maximal voluntary force produced by a muscle or muscle group (Taylor et al., 2000a). Several mechanisms may contribute to fatigue including peripheral, i.e. changes to muscle fibre processes (muscular), and central, i.e. an inability to activate the α -motoneurone pool (neurological). During sustained intense contractions, blood flow into the muscle can be restricted; this localised ischemia does not allow the recovery of muscle fibres and can affect intracellular ion concentration, which may reduce the rate of cross-bridge cycling thus attenuating force (Taylor et al., 2000a). However, during intermittent contractions interspersed with periods of relaxation, commonly performed in during athletic situations and within experimental study design, ischemia does not occur as the rest intervals between contractions enables normal blood flow, thus limiting the possibility of peripheral muscle fatigue affecting force production (Taylor et al., 2000a). One method to determine whether muscular fatigue is present is by examining neuromuscular activity during contraction (EMG). The mean and median EMG frequency content during contraction are reflective of the conduction velocities of the active muscle fibres. A reduction in the EMG frequency could be reflective of a slower conduction velocity, indicative of a reduced input by the fast twitch fibres as they fatigue, thus enabling the slow twitch fibres to comprise a greater proportion of the EMG signal, reducing the frequency content accordingly (Cifrek et al., 2009). Therefore, examining the EMG frequency content in addition to amplitude may enable a greater understanding of the mechanisms underpinning any reductions in force.

In addition to local muscular fatigue, central or neurological fatigue at the spinal or supra spinal level, may compromise recruitment of the α -motoneurone pool and reduce force output. The activation of the α -motoneurone pool is the sum of descending neural drive from the motor cortex and further excitatory input from type Ia and II muscle afferents, and inhibitory input from type Ib, III and IV muscle afferents. Intermittent contractions (minimum total duration > 5 min) have been shown to reduce maximal elbow flexor moment (Taylor et al., 2000a) with greater reductions in moment apparent from a longer total duration of contraction. Interestingly, magnetic stimulation of the motor cortex indicated that the primary location of the fatigue was supraspinal (within the motor cortex) and that the change in cortical stimulated moment also increased with longer total duration contractions. Maganaris et al. (2006) reported a significant reduction in isometric plantarflexor moment following 11 progressively intense contractions. Although EMG analysis was not reported, the twitch interpolation method revealed no further increase in moment during stimulation. This finding prompted the authors to conclude that the plantarflexors were fully activated and any reduction in moment was not attributable to reduced neuromuscular activity. Interestingly, a significant reduction in muscle operating length (gastrocnemius medialis) was also detected (Maganaris et al., 2006), which may explain the reduction in joint moment as the plantarflexors operate on the ascending limb of their force-length curve (Maganaris, 2001, 2003). Therefore, further research examining both neuromuscular activity and MTC mechanics should be performed to elucidate the mechanisms underpinning force reductions after intense contractions. It should also be noted that increased

tendon length might also occur following stretch if tendon stiffness is reduced (Kubo et al., 2001a). Thus additive effects are possible if stretching is performed after these contractions.

2.8.3. Effects of intense contractions on tendon stiffness

Tendons display a viscoelastic response to loading and deform according to the tensile load placed through the tissue (Maganaris et al., 2006). The degree of deformation (length change) is dictated by 1) the load transmitted through the tendon and 2) the stiffness of the tendon, with stiffer tendons deforming to a lesser extent than more compliant tendons under the same absolute load. Equivocal reports exist on the effects of stretch to tendon stiffness with some (Kubo et al., 2001a) but not others (Morse et al., 2008) detecting any significant reduction, which may be attributable to differences in the duration of the applied stretch. However, intense contractions transmit far greater forces through the tendon than even the most intense passive stretch (~ ×5), which results in greater tendinous strain. Unsurprisingly, significant reductions in tendon stiffness and increases in tendon strain have been reported following maximal isometric contractions in the knee extensor tendon (Kubo et al., 2001b) and in the Achilles tendon (Maganaris et al., 2006). Kubo et al. (2001b) reported significant reductions in tendon stiffness and muscle operating length but no change in isometric knee extensor moment following fifty 1-s maximal contractions. While Maganaris et al. (2006) also reported similar changes in mechanical properties of the GM-Achilles MTC but also reported concomitant significant reductions in plantarflexor moment (6%) following 11 isometric contractions of progressing intensity. Clearly, intense muscular contractions transmit large forces through the tendon, however, the paucity of relevant literature and equivocal findings indicate further research is required to fully elucidate the effects on mechanical properties and force production.

2.9. Summary

The plantarflexors are an important muscle group providing propulsive force about the ankle during locomotion and in many other athletic activities. As such, determining the effects of interventions commonly employed to prepare the plantarflexors for intense muscular activity is important. There is a growing body of research that suggests acute bouts of passive stretch can result in significant impairments in force and power production, while the effects of intense muscular contractions is less clear. Furthermore, to the author's knowledge, no research has specifically examined the combined effects of these interventions. Therefore, the major aims of the present research is to examine the effects of moderate duration (3 min) stretch on plantarflexor force and to identify the underlying mechanisms associated with any force losses incurred (Study 1). As pre-performance routines typically include both stretching and strong muscular contractions, a further aim is to determine the effects of a series of maximal contractions on force production and whether these mitigate or compound the effects of subsequent stretching (Studies 2 & 3).

Chapter 3

Study 1

Moderate-duration static stretch reduces active and passive plantarflexor moment but not Achilles tendon stiffness or active muscle length

3.1. Abstract

The effects of static stretch on muscle and tendon mechanical properties and muscle activation were studied in fifteen healthy human volunteers. Peak active and passive moment data were recorded during plantarflexion trials on an isokinetic dynamometer. EMG monitoring of the triceps surae muscles, real-time motion analysis of the lower leg and ultrasound imaging of the Achilles-medial gastrocnemius muscle-tendon junction were simultaneously conducted. Participants performed two conditions, one control (no stretch) and one experimental (three 60-s static stretches) before being re-tested 2 min and 30 min post-stretch. No significant differences were detected in any measure during the control condition. During the experimental condition, peak concentric moment was significantly reduced after stretch; 60% of the deficit was recovered at 30 min post-stretch. This decrease in force was accompanied by, and correlated with ($r = 0.81$; $P < 0.01$) reductions in peak triceps surae EMG amplitude, which was fully recovered at 30 min post-stretch. Furthermore, Achilles tendon length was significantly shorter during the concentric contraction after stretch and at 30 min post-stretch. However, no change in tendon stiffness was detected. Finally, passive joint moment was significantly reduced after stretch but fully recovered by 30 min post-stretch. These data indicate that the stretching protocol used in this study induced losses in concentric moment that were accompanied by, and related to, reductions in neuromuscular activity, but were not associated with alterations in tendon stiffness or shorter muscle operating length. Reductions in passive moment were associated with reductions in muscle stiffness, whereas tendon mechanics were unaffected by the stretch. Importantly, the impact on mechanical properties and neuromuscular activity was minimal at 30 min post-stretch.

Keywords: Triceps surae, force deficits, tissue mechanics, electromyography

3.2. Introduction

Pre-performance stretching routines, which are commonly used by athletes in the belief that they aid performance and reduce injury risk, have come under increased scrutiny following equivocal support from research as to their influence to injury risk (Gleim & McHugh, 1997; Thacker et al., 2004; Weldon & Hill, 2003; Witvrouw et al., 2004), and reports that they induce significant decrements in force and power production (Avela et al., 1999, 2004; Behm et al., 2001; Brandenburg, 2006; Cornwell et al., 2002; Cramer et al., 2004, 2007; Fowles et al., 2000; Kay & Blazevich, 2008; Knudson & Noffal, 2005; Kokkonen et al., 1998; Maisetti et al., 2007; McHugh & Nesse, 2008; Nelson et al., 2001a, 2001b; Ogura et al., 2007; Siatras et al., 2008; Viale et al., 2007; Weir et al., 2005; Young et al., 2006). While these stretch-induced force and power reductions have obvious performance implications, the mechanisms underpinning these potential losses are not fully understood. Furthermore, the time course of force decrements and the possible mechanical and physiological changes that cause them have yet to be fully elucidated. Further study is of particular importance for the triceps surae muscle group because of its relative importance in lower limb force and power production during locomotion (Czerniecki et al., 1991; McClay & Manam, 1999; Winter, 1983).

Two primary mechanisms implicated in the stretch-induced force loss phenomenon include: 1) a reduced neuromuscular activity (Avela et al., 1999, 2004, Cramer et al., 2007; Fowles et al., 2000; Rosenbaum & Henning, 1995) and 2) changes in the mechanical properties of muscle-tendon complex (MTC) (Cramer et al., 2004; Fowles et al., 2000; Kay & Blazevich, 2008; Nelson et al., 2001a, 2001b, Weir et al., 2005). Reductions in neuromuscular activity (measured by electromyography; EMG) have been reported simultaneously with stretch-induced force losses after 30 min (Fowles et al., 2000) and after 1 hour (Avela et al., 1999) of intermittent static stretching, although the relationship between the changes in EMG and changes in force development has not been explicitly examined. Nonetheless, significant decreases in plantarflexor force have also been reported to occur without a change in neuromuscular activity after 4×15 s (Kay & Blazevich, 2008) and after 5×120 s (Weir et al., 2005) static stretches. Furthermore, Fowles et al. (2000) reported the complete recovery of neuromuscular activity 15 min post-stretch while plantarflexor moment remained impaired after one hour. These results are suggestive that a mechanism other than a reduction in neuromuscular activity is at least partly responsible for the force decrements.

The stiffness of tendinous structures has been significantly correlated ($r = 0.57-0.78$) with both isometric and concentric force (Wilson et al., 1994). An alternate explanation is that acute stretching reduces tendon stiffness, which could increase neuromechanical delay (Cresswell et al., 1995) and reduce the rate of force development (Bojsen-Møller et al., 2005; Edman & Josephson, 2007; Kubo et al., 2001b). This reduction in tendon stiffness could also decrease the active muscle length at a given force level. In the human plantarflexors a decrease in muscle length would reduce the maximal force according to its force-length relationship (Maganaris, 2001, 2003). A significant increase in Achilles tendon compliance has been previously reported after 10 min of static plantarflexor stretch (Kubo et al., 2001a). In contrast,

5 min of plantarflexor stretch (Morse et al., 2008) resulted in Achilles tendon stiffness remaining unaffected while gastrocnemius medialis (GM) muscle stiffness decreased. Nonetheless, significant differences in study design do not allow a clear determination of the effects of static stretch on tendon stiffness, although both studies reported significant reductions in passive moment indicating that there were substantive changes in the mechanical properties of the MTC. However, the effects of stretch to mechanical properties of the MTC and any subsequent effect on force transfer and muscle operating length remain unclear.

Some studies have revealed no change in passive moment following three 45-s stretches (Magnusson et al., 1998) or a single 90-s stretch (Magnusson et al., 2000), indicating that the increased ROM that succeeded the stretch was attributable to an increased 'stretch tolerance' rather than any change in the mechanical properties of the tissues. Together, these studies are suggestive that longer duration stretches (>5 min) might impact mechanical properties of the MTC, whereas shorter duration stretches might not. Furthermore, some more recent studies (Kay & Blazevich, 2008; Knudson & Noffal, 2005; Ogura et al., 2007; Ryan et al., 2008; Siatras et al., 2008; Young et al., 2006) have indicated a clear dose-response effect where reductions in maximal force become more significant with longer stretch durations. Whilst a number of studies have reported a negative effect of acute stretching on force production (Avela et al., 1999, 2004, Brandenburg, 2006; Fowles et al., 2000; Kay & Blazevich, 2008; Knudson & Noffal, 2005; Kokkonen et al., 1998; Maisetti et al., 2007; McHugh & Nesse, 2008; Ogura et al., 2007; Siatras et al., 2008; Viale et al., 2007; Weir et al., 2005; Young et al., 2006), the extensive stretch durations (10-60 min) used in many studies do not reflect the durations of stretch commonly employed by athletes prior to performance. Limited data exist describing the effects of stretch on changes in muscle force production, neuromuscular activity and mechanical properties of the MTC when more commonly used stretch durations (<3 min) are utilised. Furthermore, few studies have examined the effects of stretch on both active and passive force at several joint angles, within the same study protocol and, to the authors knowledge, none have included simultaneous neuromuscular activity (EMG) and muscle-tendon imaging protocols to determine the possible contributions of changes in neuromuscular activity and muscle-tendon mechanical properties to the changes in active and passive forces (see Tables 2.7.1 and 2.7.2).

Given the above, the primary aims of the present study were to determine the effects of three 60-s static stretches on active (concentric) and passive plantarflexor force and to determine whether any decrement persisted to 30 min post-stretch. The second aim of this study was to examine neuromuscular activity (EMG) in the triceps surae and correlate any changes in EMG with changes in joint moment to determine the strength of any relationship. The final aim of the study was to measure GM muscle operating length and Achilles tendon stiffness in an attempt to elucidate the relative importance of the mechanisms underpinning possible stretch-induced force losses. Accordingly, the following hypotheses were developed:

Experimental Hypothesis 1 - There will be a significant reduction in active and passive plantarflexor moment and EMG post-stretch

Null Hypothesis 1 - There will be no significant reduction in active and passive plantarflexor moment and EMG post-stretch

Experimental Hypothesis 2 - There will be a significant correlation between post-stretch reductions in concentric moment and EMG

Null Hypothesis 2 - There will be no significant correlation between post-stretch reductions in concentric moment and EMG

Experimental Hypothesis 3 - There will be a significant decrease in tendon stiffness and increase in concentric tendon length post-stretch

Null Hypothesis 3 - There will be no significant decrease in tendon stiffness and increase in concentric tendon length post-stretch

3.3. Methods

An important consideration for any body of research is to determine whether the methods employed can produce accurate, reliable and valid data. Within such experimental models, several methods can be employed to enhance the quality of the data collected and the validity of the interpretation of the meaning and importance of the findings from the subsequent analysis of the data. These methods can include calculating the appropriate sample size necessary to reach a desired level of statistic power, the implementation of pilot testing, the inclusion of familiarisation sessions, the randomisation of trial order, and the inclusion of a control group or control condition. The 'gold standard' for empirical based quasi-experimental models, as used in the present research, is the randomised control trial (RCT), which incorporates both randomisation of trial order and the inclusion of a control group. The inclusion of such a protocol can help to ascertain the reliability of the data and whether any random or systematic error may have impacted upon the data collected, results obtained from statistical analysis, and subsequent interpretation and importance of these results.

During test re-test studies, as used in the present research, where an intervention is included between trials, the reliability of the methods employed and dependent variables examined, is arguably one of the most important parameters. Ensuring high reliability should enable valid conclusions to be drawn about the impact of the intervention where changes in these variables

are apparent following the intervention. The reliability of the variables examined and methods employed can be determined using several statistical tools including calculating the intraclass correlation coefficient (ICC), coefficient of variation (CV) and using statistical analysis difference tests such as paired t-tests or analyses of variance (ANOVA). These can establish both systematic and random error to determine the reliability of the method and variables measured. The following research used a RCT quasi-experimental model, which included 1) extensive pilot testing to determine the validity of the testing protocols and any impact on the dependent variables measured, 2) familiarisation and randomisation processes to remove any systematic error such as learning or fatigue affects influencing the data, and 3) a control condition to determine reliability of the dependent variables. The following sections will describe the methods employed during pilot testing to determine the reliability of the methods and measures within the present research and the methods employed in the experimental stretch-based study.

3.3.1. Power analyses

To ensure an adequate participant population was recruited for the study to reach statistical power (set at .8), effect sizes were initially calculated (see Appendix 1) from related research for maximal joint moment (Behm et al., 2001; Avela & Komi, 1998), tendon stiffness (Kubo et al., 2001a; Morse et al., 2008), passive joint moment (Kay & Blazevich, 2008; Weir et al., 2005), and EMG (Cornwell et al., 2002; Behm et al., 2001). The average sample size for joint moment, tendon stiffness, passive joint moment and EMG was calculated at 15, 5, 12 and 7 respectively. Therefore, to ensure an adequate population to reach statistical power for all the variables included within the present research (~15), and considering the possibility of participant withdrawal, 20 participants were recruited to participate in each of the three studies conducted within the present research.

3.3.3. Participants

Twenty active participants with no recent history of lower limb injury or illness volunteered for the study after providing written and informed consent (see Appendix 2). Due to participant withdrawal and incomplete data collection, complete data from 15 participants (7 women and 8 men; age = 20.2 ± 2.4 y, mass = 68.2 ± 13.4 kg, height = 1.7 ± 0.1 m) were subsequently used for analysis. No significant difference in stretch-induced force deficits between the sexes (Viale et al., 2007) has been reported so the use of men and women should not influence the results. The participants refrained from intense exercise, flexibility training and stimulant use for 48 hr prior to testing. Ethical approval was granted by the Ethics Committee of The School of Health at The University of Northampton (see Appendix 2) and the study was conducted in accordance with the Declaration of Helsinki.

3.3.4. Equipment & Measures

An isokinetic dynamometer (Biodex System 3 Pro, IPRS, Suffolk, UK) was used to measure passive and concentric plantarflexor joint moment, joint range of motion (ROM) and velocity (more detail is reported later). Skin-mounted bi-polar double differentiated active electrodes (model MP-2A, Linton, Norfolk, UK) measured EMG activity of the gastrocnemius medialis (GM), gastrocnemius lateralis (GL), lateral aspect of the soleus (Sol) and tibialis anterior (TA). Three infrared digital cameras (ProReflex, Qualisys, Gothenburg, Sweden) recorded movement of the foot, data were then directed to a personal computer running Track Manager 3D software (v.1. 8.226, Qualisys). Ultrasound video imaging (LOGIQ Book XP, General Electric, Bedford, UK) using a wide-band linear probe (8L-RS, General Electric) and coupling gel (Ultrasound gel, Dahlhausen, Cologne, Germany) between the probe and skin recorded GM-Achilles muscle-tendon junction (MTJ) position; data were later manually digitised (Peak Motus, Englewood, CO). Motion analysis and ultrasound data were synchronised using a 5-V ascending transistor-transistor linear (TTL) pulse, which enabled GM muscle and Achilles tendon lengths to be calculated.

3.3.5. Protocol

The participants were initially familiarised with the testing protocol one week prior to data collection. This included participants completing the passive, active and stretch trials (explained in detail later) to ensure they were both comfortable with the testing protocol and competent in achieving maximal voluntary contractions. They visited the laboratory on two occasions separated by one week, once under control conditions (no stretch) to determine the reliability of the measures, and once under experimental conditions (stretch intervention). The order of testing was randomised to reduce any possible learning effect with 50% of the participants undertaking the stretch intervention first and the remaining participants completing the control (no stretch) condition first. During the experimental sessions, the participants performed a warm-up on a Monark cycle for 5 min by cycling at 60 rpm with a 1-kg resistance load producing a power output of 60 W. The participants then sat upright in the chair of an isokinetic dynamometer (Biodex System 3 Pro, IPRS, Suffolk, UK) with the knee fully extended (0°) to ensure the gastrocnemii were also placed under significant stretch and contributed significantly to plantarflexor joint moment (Cresswell et al., 1995; Kawakami et al., 1998). The ankle was placed in neutral position (0°) with the sole of the foot perpendicular to the shank, and the lateral malleolus aligned to the centre of rotation of the dynamometer. The participants' ankles were then passively rotated through their full ranges of motion at $0.087 \text{ rad}\cdot\text{s}^{-1}$ ($5^\circ\cdot\text{s}^{-1}$) before they performed a maximal concentric plantarflexor contraction at $0.087 \text{ rad}\cdot\text{s}^{-1}$ through the full ROM. By rotating the ankle, three 60-s static plantarflexor stretches were imposed with 60 s rest after each stretch by rotating the ankle (dorsiflexion). They were subsequently retested at 2 min and at 30 min post-stretch. During the control condition, 5 min of rest replaced the stretching protocol used during the experimental condition; all other procedures were identical to the experimental condition.

3.3.6. Participant positioning on the isokinetic dynamometer during the passive and stretch trials
The position of the participant at the hip and knee joints needed to be consistent between trials to remove it as a possible external variable, which may impact upon the reliability of ankle ROM and joint moment data recorded by the dynamometer. Furthermore, the positions of the hip and knee joints needed to be considered as these may impact upon the validity of the data collected (explained later). To aid clarity, all joint positions are reported relative to the anatomical position, which for all joints is considered 0°.

The triceps surae muscle group's (soleus, gastrocnemius lateralis, gastrocnemius medialis) contribution to plantarflexor joint moment has been calculated to be between 72% (Murray et al., 1976) and 93% (Giddings et al., 2000), highlighting its relative importance to ankle joint moment and the propulsive forces generated during gait. Although all three muscles have a common insertion point through the Achilles tendon onto the calcaneus, the soleus is a mono-articular muscle which crosses the ankle joint, while the gastrocnemii are bi-articular and also cross the knee joint. Therefore, the position of the knee joint can influence the force produced by the gastrocnemii as increased flexion of the knee would shorten the muscles, which, according to their length tension properties, would significantly reduce their force generating capacity (Maganaris, 2001, 2003). Cresswell et al. (1996) reported that plantarflexor joint moment decreased by 40% when the knee was flexed compared to an extended knee position and attributed this decline to the gastrocnemii muscles being placed in a disadvantageous length, unable to contribute to joint moment. Furthermore, while the knee is flexed, ankle rotation through dorsiflexion during the stretch protocol may not place the gastrocnemii under significant stress thus resulting in the stretch protocol having little mechanical effect to these muscles. Given that ultrasound imaging of the GM-Achilles MTJ was to be used to determine the effects of stretch on Achilles tendon and GM muscle stiffness, the knee was placed in full extension (0°) for all experimental trials (passive, active and stretch), to ensure the gastrocnemii muscles were significantly stretched and contributed to plantarflexor joint moment.

In initial pilot testing, the participants sat in an upright position in the dynamometer with the right knee fully extended (0°). As the ankle was rotated by the dynamometer, the dorsiflexor ROM was often limited, accompanied by significant knee pain across the popliteal crease, a common location for pain exhibited during testing for neural tension. Whilst muscles are capable of significant deformation under stress, neural tissue has relatively little capacity for length change. Both afferent and efferent nerves associated with the plantarflexors are located within the spinal column. Therefore, with the knee placed in full extension, the increased hip flexion would place these nerves under significant tension, which would only be exacerbated by ankle dorsiflexion. Pain was not reported and ankle dorsiflexion ROM increased when participants were reclined from 85° to 70° hip flexion, ROM then increased further as the participants were reclined to 55° hip flexion. However, there was no further increase in ankle dorsiflexion with hip flexion <55° suggesting that full ankle ROM had been achieved. It was also noticed that when the participants were placed in a prone position, the heel tended to displace from the footplate at higher ankle dorsiflexion ROM prior to the participant terminating rotation. This displacement

moved the centre of rotation of the ankle (estimated at the lateral malleolus) away from the centre of rotation of the dynamometer. This movement was not apparent when the participants were placed at 55° of hip flexion. Therefore, given that reliable ankle joint position and full dorsiflexion ROM could only be attained with the hip at 55° of hip flexion, the passive ROM and stretch trials were conducted in this position.

3.3.7. Joint moment and ROM during the passive trials

To ensure that the passive joint moment data truly reflected passive conditions, a movement velocity of $0.087 \text{ rad}\cdot\text{s}^{-1}$ ($5^\circ\cdot\text{s}^{-1}$) was employed, with the goal of limiting the likelihood of a significant myotatic stretch reflex response (Maisetti et al., 2007; McNair et al., 2001; McNair & Portero, 2005). To further ascertain that all muscles were inactive, continuous EMG monitoring was also conducted throughout the passive trials. Consistent with previous research (Fowles et al., 2000), EMG amplitude at rest was calculated at 1-3% of MVIC, considered to be noise within the signal (see Figure 3.3.1). Therefore, participants' data were removed if EMG increased above 3% of MVIC as this would indicate neural activity, either myotatic or volitional, which would possibly invalidate the passive moment data (Fowles et al., 2000).

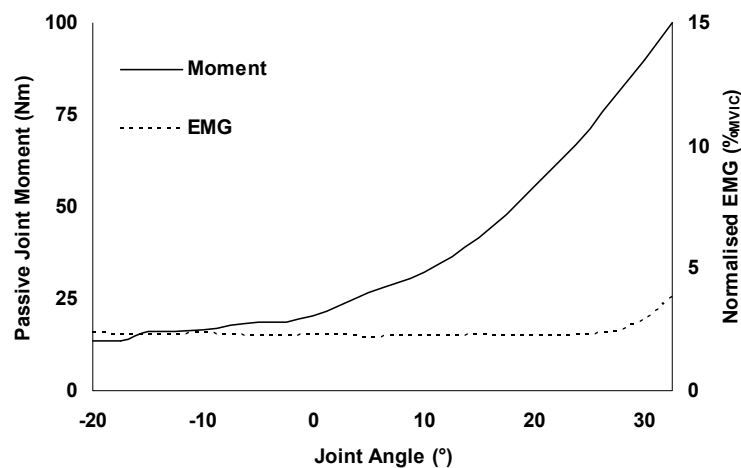

Figure 3.3.1. Joint moment and EMG during a passive trial.

Full ROM was determined by rotating the participants' ankles until reaching the point of discomfort, a common stretch intensity employed in both athletic stretching and during stretch studies (Behm et al., 2001; Cramer et al., 2007; Kay & Blazevich, 2008; Ryan et al., 2008), where the participants stopped the rotation by pressing a hand-held release button. Passive joint moment was recorded throughout the trials and then normalised as a percentage of the first trial's maximum passive joint moment ($\%M_{pas}$) to remove inter-individual differences in joint moment between participants. Pilot testing revealed at the anatomical position (0°), ankle joint moment did not reflect the normal linear stress-strain (force-length) relationship (see Figure 3.3.2) expected with a change in joint angle (reflective of a change in tissue length). This was indicative of the MTC tissues being at a slack length rather than the toe or linear region of the

stress-strain curve. To remove inter-variability in ankle ROM influencing the results, ROM was calculated from the observed inflection point (0%), where joint moment (solid line) clearly deviated from its initial linear slope, indicative of the MTC tissues moving onto the toe region of the stress-strain curve (dashed line), to maximal dorsiflexion (100%). As disparate results have been reported in the literature regarding the effects of stretch to passive joint moment (stiffness of the MTC) possibly due to the ROM at which passive moment was calculated, the present study aimed to determine the effects of stretch on passive joint moment through a range of joint angles at 10%, 30%, 50%, 70% and 90% of ROM.

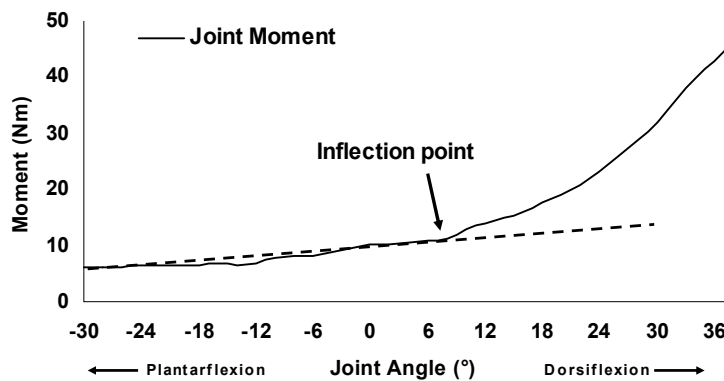

Figure 3.3.2. Passive ankle joint moment recorded during a slow ($5^{\circ}\cdot s^{-1}$) dorsiflexion rotation.

To determine ankle moment during the passive trials, the participants' ankles were passively rotated through their full ROM at $0.087 \text{ rad}\cdot s^{-1}$ until reaching the point of discomfort, where the participants were instructed to volitionally terminate the rotation by pressing a hand held release button. During testing, passive joint moment, joint angle and angular velocity data were directed from the dynamometer to a high level transducer (model HLT100C, Biopac, Goleta, CA) before analogue-to-digital conversion at a 2000-Hz sampling rate (model MP150 Data Acquisition, Biopac). The data were then directed to a personal computer running AcqKnowledge software (v3.8.2, Biopac) and filtered with a double pass 6 Hz Butterworth low pass filter. Full ROM was calculated from the inflection point (mean angle = $0.8 \pm 4.8^{\circ}$ dorsiflexion), where a clear change in the slope of the passive moment curve occurred (see Figure 3.3.2), to the volitional end of ROM. Passive moment, recorded throughout the trial, was then expressed as a percentage of the maximum pre-stretch passive joint moment ($\%M_{pas}$). The normalised moment data calculated at 10%, 30%, 50%, 70%, and 90% of maximum ROM were used for analysis to account for inter-individual differences in joint flexibility (ROM).

3.3.8. Participant positioning on the isokinetic dynamometer during the active trials

During pilot testing for the concentric trials, significantly greater moment was being produced by the participants when compared to the passive and stretch trials. Despite use of the Velcro ankle strapping placed about the ankle joint, this resulted in significant displacement of the heel from the dynamometer footplate, hip elevation and sliding of the upper body in the dynamometer chair. This displacement occurred in the prone position, at 55° and 70° of hip flexion, however this movement was visibly reduced at 85°. Although ankle dorsiflexion ROM was reduced in this position, to ensure the validity of the concentric joint moment data, the concentric trials were conducted in an upright seated position with the hip flexed to 85°.

3.3.9. Concentric moment and ROM during the active trials

The participants' ankles were passively rotated through their ROM at 0.087 rad·s⁻¹ until reaching the point of discomfort before they were instructed to maximally contract the plantarflexors isometrically. The footplate of the dynamometer was released once maximal isometric moment was attained (i.e. there was a visible plateau in the moment trace), which enabled the participants to continue to maximally contract the plantarflexors through a concentric movement at 0.087 rad·s⁻¹ through their full ROM. This resulted in a joint moment trace rapidly rising to a plateau during the isometric phase and a linear reduction during the concentric phase (see Figure 3.3.3), indicative of the force-length characteristics of the triceps surae (Maganaris, 2001, 2003). Data from participants who did not achieve this linear reduction in joint moment during the concentric trial were not included in analysis as this was interpreted as a sub-maximal contraction.

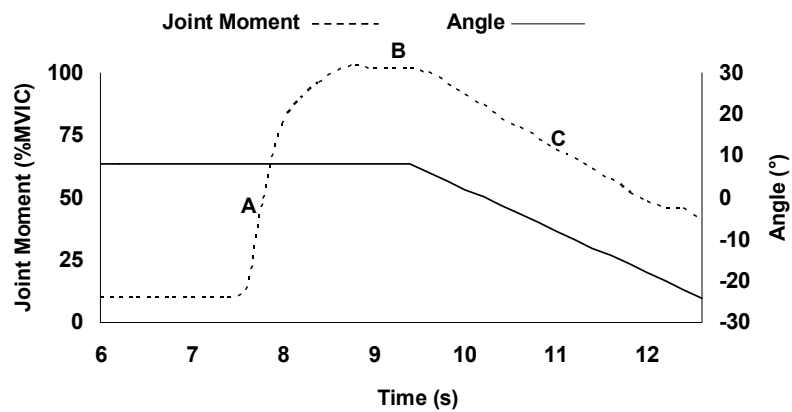

Figure 3.3.3. Joint moment recorded during a concentric plantarflexion trial. The participants performed an isometric contraction (A) until a plateau was reached (B), then the footplate of the dynamometer was released and a concentric contraction (C) was performed through the full ROM.

During testing, joint moment, joint angle and angular velocity data were directed from the dynamometer to a high level transducer (model HLT100C, Biopac) before analogue-to-digital conversion at a 2000-Hz sampling rate (model MP150 Data Acquisition, Biopac). The data were then directed to a personal computer running AcqKnowledge software (v3.8.2, Biopac) and filtered with a double pass 6 Hz Butterworth low pass filter. Concentric plantarflexor moment was normalised as a percentage of the pre-stretch maximum plantarflexor moment during the maximum voluntary isometric contraction (%_{MVIC}). As inter-participant flexibility was variable, maximal concentric moment was recorded throughout the full ROM but data were analysed only at 50%, 70% and 90% of the full ROM to determine the effects of stretch at a range of joint angles and muscle lengths, calculated between full plantarflexion (0%) and full dorsiflexion (100%). Analysis was not conducted at 10% or 30% of ROM as the slow concentric velocity ($5^{\circ}\cdot^{-1}$) used resulted in a total contraction period of approximately 12 s, which would have induced substantial fatigue and significantly influenced the results at these joint angles.

3.3.10. Stretch protocol

The participants' ankles were passively rotated through their full ROM at $0.087\text{ rad}\cdot\text{s}^{-1}$ until reaching the point of discomfort, a subjective position regularly used in stretch studies (Behm et al., 2001; Cramer et al., 2007; Kay & Blazevich, 2008; Ryan et al., 2008). The velocity of the movement is commonly used in studies examining passive mechanics and stretch interventions as it was too slow to elicit a significant myotatic stretch reflex response (Maisetti et al., 2007, McNair et al., 2001; McNair & Portero, 2005). This ensured that full ROM was achieved and a substantial stress was applied to the MTC. The participants were held in the stretched position for 60 s and then released at $0.087\text{ rad}\cdot\text{s}^{-1}$, returning the foot to a fully plantarflexed position. The stretch protocol was repeated twice (after 60 s of rest) giving a total stretch duration of 180 s. EMG amplitude, joint moment, ROM, movement velocity, ultrasound imaging of the muscle-tendon junction and video imaging of the lower leg were continuously and synchronously recorded throughout the stretch period (described later).

3.3.11. Electromyographic (EMG) analysis

Surface EMG analysis usually consists of a bi-polar electrode configuration, which measures the sum of electrical activity produced by active motor units within the electrodes measurement volume (Farina et al., 2004). However, to enable meaningful and reliable data to be produced, the location and preparation of the electrode sites and processing of the raw EMG signal should be considered. The electrode location and orientation for the triceps surae muscles and tibialis anterior were determined from SENIAM guidelines and recommendations reported in De Luca (1997). According to these guidelines, the skin over these sites was shaved, lightly abraded, and then swabbed with ethanol to remove residual skin cells and oils, to reduce skin resistance and to minimise the small chance of infection. Skin-mounted bi-polar double differentiated

active electrodes (model MP-2A, Linton) with a 12 mm diameter, a fixed inter-electrode distance of 18 mm and central bar of 12 mm by 3 mm, were then positioned over the central portion of the muscle bellies of the GM, GL, Sol and TA, in the general direction of the muscle fibres for the given muscle. A ground electrode was positioned over the medial aspect of the patella of the same limb.

During pilot testing, the EMG signals were pre-amplified at the electrode site (gain = 300, input impedance = 10 G Ω , common mode rejection ratio = > 100 dB at 65 Hz) resulting in a low noise input (<1.2 μ V RMS) and then directed to a high level transducer (model HLT100C, Biopac) before analogue-digital conversion (model MP150 Data Acquisition, Biopac). The EMG signals were then directed to a personal computer running AcqKnowledge software (v3.8.2, Biopac) where they were sampled at 2000 Hz (Bilodeau et al., 2003; Morse et al., 2008). The data were then filtered using a 20- to 500 Hz band pass filter (DeLuca, 1997; Hwang & Abraham, 2001; Kay & Blazevich, 2008; Kinugasa et al., 2005; Oksa et al., 1996). A fast fourier transformation (FFT) of the filtered EMG data enabled a spectral frequency analysis of the data. Observation of these data revealed there were no additional sources of noise within the spectral frequencies passed by the filter (see Figure 3.3.4), therefore, no further additional filtering of the data was performed.

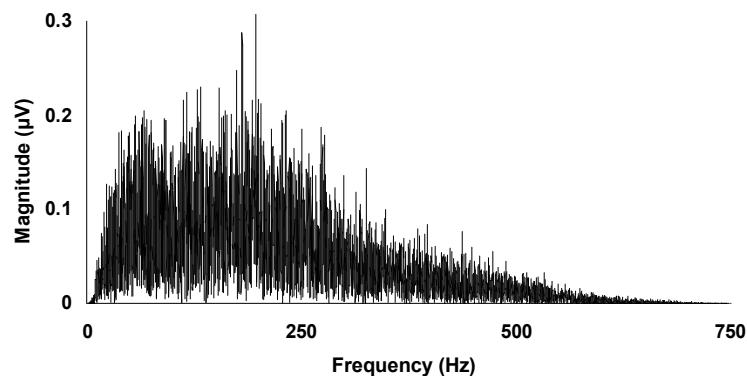

Figure 3.3.4. Fast fourier transformation (FFT) depicting the spectral frequency of the filtered EMG signal.

The filtered signal was also converted to root mean squared (RMS) EMG (De Luca, 1997) with a moving 250 ms sampling window. This sampling window was employed as a window < 100 ms resulted in a variable signal during the maximal contractions, limiting the ability to detect a real change in neuromuscular activity rather than normal variation. Finally, the RMS EMG was normalised as a percentage of the peak EMG amplitude (De Luca, 1997) recorded during the first maximal voluntary isometric contraction (% M_{VIC}). The normalised EMG amplitude was then used as a measure of neuromuscular activity; the signals for GM, GL and Sol were also averaged to obtain a representative activity of the triceps surae (TS) muscle group. The antagonist tibialis anterior (TA) EMG data were processed and normalised using the same method. Conversion of the raw EMG data to normalised data can be seen in Figure 3.3.5 below

calculated during an isometric contraction. Little difference was seen between the raw and filtered signals, although signal drift was apparent in the raw signal, which was removed by the filtering process. Once the filtered data were converted to RMS, a clear relationship could be seen between the moment and EMG curves. This relationship became more obvious when both joint moment and EMG were normalised to percentages of the peak MVIC (see figure 3.3.5; D). Thus, increases in joint moment were associated almost linearly with increased EMG.

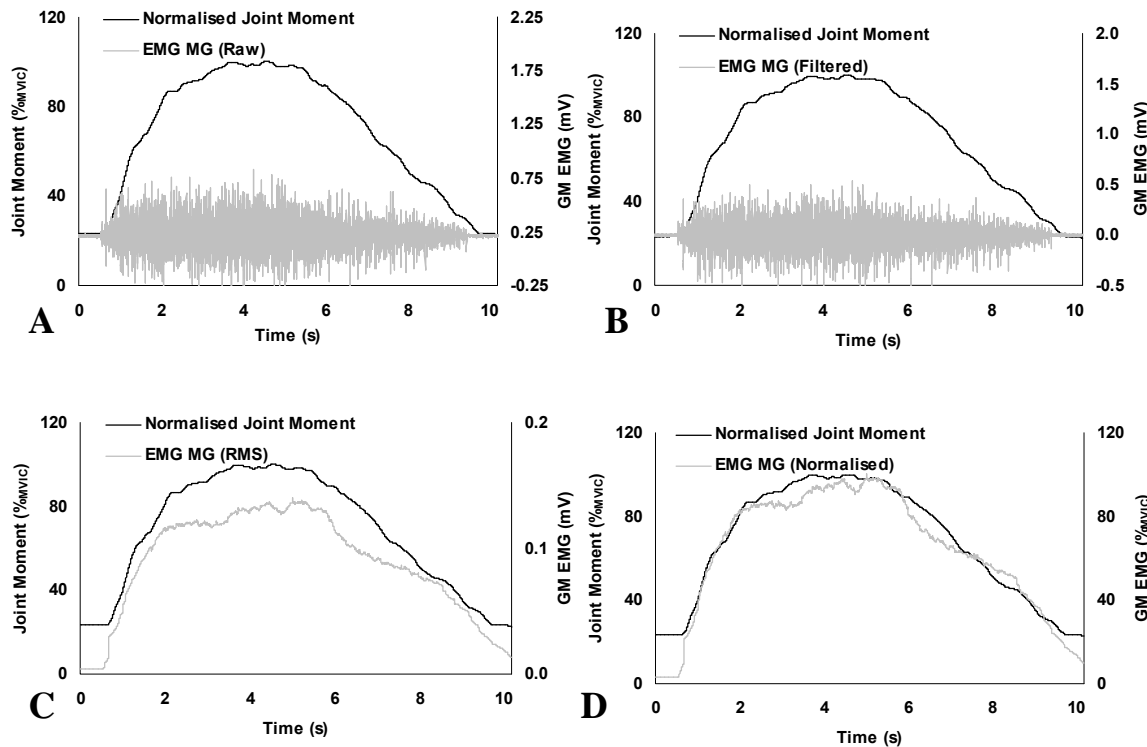

Figure 3.3.5. EMG processing. Raw EMG (A) data sampled at 2000 Hz were filtered (B; 20-500 Hz band pass), converted to RMS (C; 250 ms averaging window) and finally normalised (D) to maximal EMG activity during a maximal voluntary isometric contraction (MVIC).

3.3.12. EMG:moment relationship

Significant correlations have been reported between neuromuscular activity (EMG) and joint moment in a range of muscle groups (Alkner et al., 2000; Bigland & Lippold, 1954; Lippold, 1952; Woods & Bigland-Richie, 1983), with EMG amplitude purportedly being indicative of the contractile state of a muscle and representative of the moment calculated about a joint. To ensure the present methods would reflect this relationship, an important aim during pilot testing was to determine whether a reduction in joint moment would reveal a reduction in the normalised EMG, accordingly, correlation analyses were conducted to determine the relationship between the normalised EMG data and normalised isometric joint moment. The participants ($n = 5$) performed a ramped isometric plantarflexor contraction with the ankle in the anatomical position (0°), knee in full extension (0°) and hip flexed to 85° to determine any relationship between Sol, GM, GL and TS (mean Sol, GM, GL) EMG amplitudes and plantarflexor joint moment. To ascertain the importance of co-contraction, a dorsiflexor

contraction was performed to enable TA activity to be correlated with dorsiflexor joint moment. A review of the stretch-induced force deficit literature revealed mean deficits of $16.5 \pm 7.5\%$ within the plantarflexors (Avela et al., 1999, 2004; Cornwell et al., 2002; Fowles et al., 2000; Kay & Blazeovich, 2008; Maisetti et al., 2007). Therefore, given the approximate reductions that could be expected, correlations were determined for mean ($n = 5$) EMG amplitudes for the Sol, GL, GM and TS muscles between 75-100% of maximal isometric joint moment. During these trials, levels of co-activation of the TA muscle revealed values between 5-20% of maximal TA EMG recorded during the dorsiflexion trial, therefore, correlations between TA EMG and dorsiflexor joint moment were only determined between these expected values.

Significant ($P < 0.01$) correlations were revealed for Sol ($r = 0.98$), GL ($r = 0.93$), GM ($r = 0.98$) and TS ($r = 0.98$) EMG amplitudes with plantarflexor joint moment (calculated between 75-100% MVIC). The very strong correlations were calculated for individual muscle EMG amplitudes and for TS muscle group EMG amplitude (see Figure 3.3.6; D) indicate that these methods should be able to identify post-stretch reductions in EMG amplitude if a reduction in joint moment occurred as suggested in the literature (Avela et al., 1999, 2004, Cornwell et al., 2002; Cramer et al., 2005; Fowles et al., 2000).

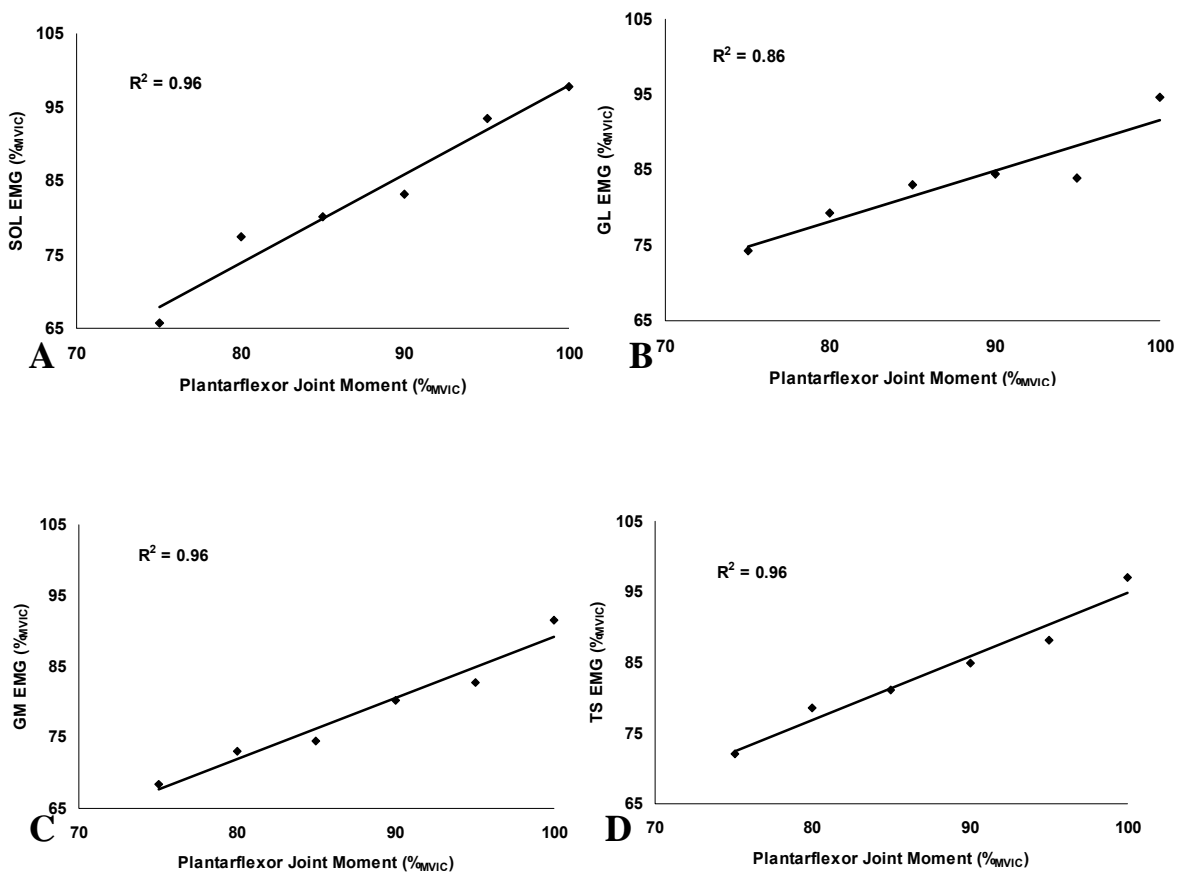

Figure 3.3.6. Correlation between soleus (Sol; A), gastrocnemius lateralis (GL; B), gastrocnemius medialis (GM; C), and triceps surae (TS; D) electromyographic amplitude (EMG) and joint moment.

A significant ($P < 0.01$) correlation was also found between TA EMG and dorsiflexor joint moment indicating that co-activation accurately reflects the contribution to joint moment from the antagonistic tibialis anterior muscle (see Figure 3.3.7). Therefore, changes in TA co-activation could be important with regards to the joint moment recorded.

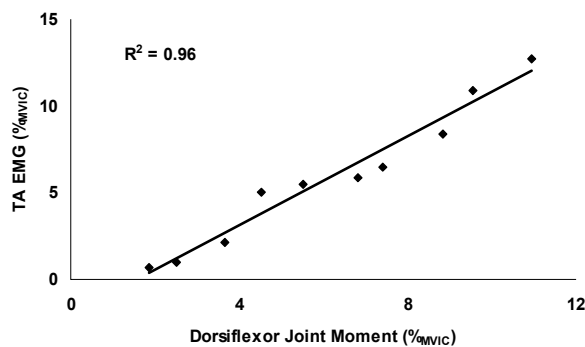

Figure 3.3.7. Correlation between tibialis anterior (TA) electromyographic amplitude (EMG) and dorsiflexor joint moment.

3.3.13. EMG processing during concentric trials

During the concentric trials, EMG was constantly monitored to allow quantification of muscle activity. EMG signals were amplified (gain = 300, input impedance = 10 G Ω , common mode rejection ratio = > 100 dB at 65 Hz) and then directed to a high level transducer (model HLT100C, Biopac) before being converted from analogue to digital at a 2000-Hz sampling rate (model MP150 Data Acquisition, Biopac). Signals were then directed to a personal computer running AcqKnowledge software (v3.8.2, Biopac) where they were filtered using 20-500 Hz band-pass filter. A linear fast fourier transformation (FFT) (calculated at 90% of ROM; 1 s window) was performed to determine the mean and median spectral frequency content of the EMG signal. The mean and median EMG frequency content during contraction are thought to be reflective of the conduction velocities of the active muscle fibres (Cifrek et al., 2009). To determine EMG amplitude, the filtered signal was converted to root mean squared (RMS) EMG with a 250 ms sample window, and normalised as a percentage of the peak amplitude recorded during a maximal isometric contraction (%MVIC). The normalised RMS EMG amplitude calculated at 50%, 70% and 90% of ROM were used as measures of neuromuscular activity. The normalised RMS EMG signals for GM, GL and Sol were also averaged to obtain a representative activity of the triceps surae (TS) muscle group. In addition, the EMG:moment ratios were calculated at 50%, 70% and 90% of ROM. The antagonist tibialis anterior (TA) EMG data were processed and normalised using the same method.

3.3.14. Motion analysis

During a 10 s calibration, three infrared digital cameras (ProReflex, Qualisys) operating Track Manager 3D (v.1. 8.226) software recorded the positions of four reflective markers on a calibration frame and the positions of two reflective markers on a calibration wand (Wandkit 750, Qualisys), which calibrated the distance within the three orthogonal planes (X = depth, Y = width, Z = height) within the cameras' field of view. Once the volume had been calibrated, the motion analysis system could accurately determine the distances between any markers within the calibrated volume and fields of view of the cameras.

Infrared reflective markers were placed on the skin over the Achilles insertion at the calcaneum (see Figure 3.3.8; *marker A*) and on the origin of the medial head of the gastrocnemius at the medial femoral epicondyle (*marker B*); determined by palpating the sites. Another marker was placed over the GM musculotendinous junction (*marker C*), determined by ultrasound; with adhesive hypoechoic tape placed on the skin aligned with this marker. A final marker was placed on the dynamometer footplate (*marker D*) to enable the motion analysis data to be synchronised with data exported from the dynamometer.

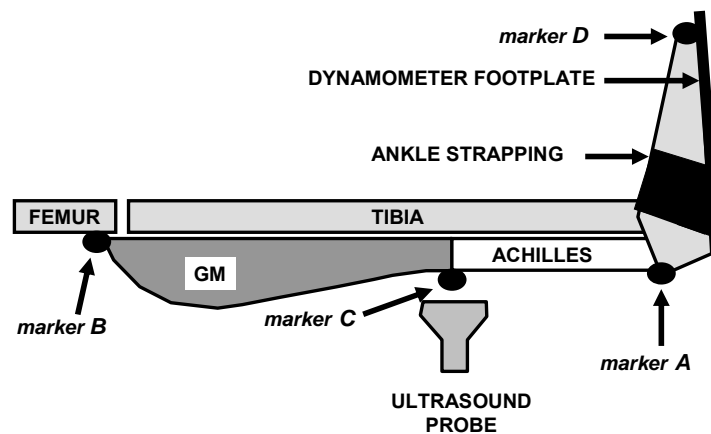

Figure 3.3.8. Reflective marker (motion analysis) and ultrasound probe positioning.

During pilot testing, the Track Manager 3D software (v.1. 8.226, Qualisys) sampled the data for one participant's trial at 100Hz to identify each marker. From this trial an automatic identification of markers (AIM) model was created, which enabled subsequent trials to be batch processed and markers to be automatically identified. This was possible only if the infrared reflective markers remained within the cameras field of view. Where markers disappeared from view, a quintic spline was used to predict marker placement and filled any gaps in the data, however, this was restricted to a maximum of 20 frames to ensure accurate prediction of the markers' coordinates within the volume. The pilot testing enabled camera positing to be modified (see Figure 3.3.9) so that during experimental testing, no participants' data was omitted from analysis as a result of loss of data due to markers being removed from the cameras field of view.

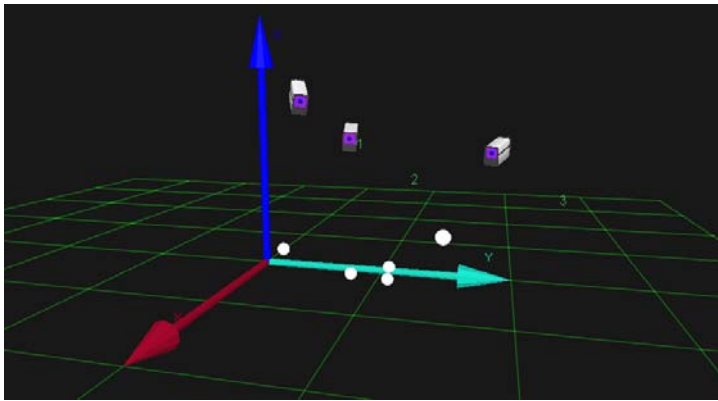

Figure 3.3.9. Camera, reflective marker and orthogonal plane positions within the calibrated volume.

During pilot testing for both passive and active trials, raw coordinate data, sampled at 100 Hz, were smoothed using a 100 ms averaging window (see figure 3.3.10) using Track Manager 3D software (v.1. 8.226, Qualisys) prior to the calculation of muscle and tendon lengths. Peak dorsiflexion was determined by observing where the reflective marker placed on the dynamometer footplate either changed direction or became stationary, which enabled the motion analysis data to be synchronised with ROM data exported by the dynamometer. Using a time-regression from this point, Achilles tendon and muscle lengths could be calculated by measuring the change in time from the peak dorsiflexion ROM to the ROM of interest.

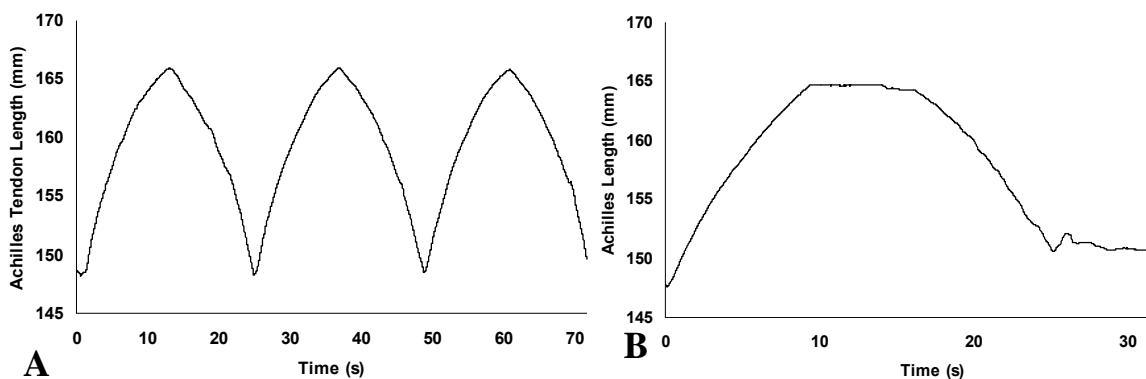

Figure 3.3.10. Motion analysis data for estimated Achilles tendon length during passive (A) and active concentric (B) trials.

Intraclass correlation coefficients (ICC) were calculated for Achilles tendon length (distance between the reflective markers placed over the MTJ (*marker C*) and Achilles tendon insertion (*marker A*)) between two passive trials at 10%, 30%, 50%, 70% and 90% of the participants' (n = 5) ROM. These ranged from 0.99 to 1.00 indicating very high reliability of the ankle movement during rotation within the dynamometer, the motion analysis digitising software, and ultimately the reliability of Achilles tendon length between trials throughout a range of joint angles. Coefficients of variation for tendon length at these joint angles (expressed as a

percentage of the mean) ranged from 0.03% to 0.10%, again indicating the high reliability of the system to reliably measure length. No significant difference was detected between trial 1 and trial 2 ($P > 0.05$) (see Figure 3.3.11) at any ROM.

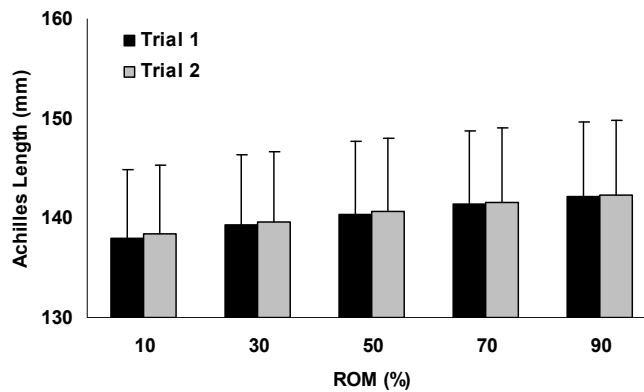

Figure 3.3.11. Achilles tendon length between pilot testing trials during passive trials at 10%, 30%, 50%, 70% and 90% of ROM.

3.3.15. Sonography

The position of the GM-Achilles MTJ was recorded with B-mode ultrasound imaging (GE LOGIQ Book XP) from a wide-band linear probe (8L-RS, GE) with coupling gel (Ultrasound gel, Dahlhausen) applied between the probe and skin. The probe had a fixed 39 mm wide aperture (field of view) but pilot testing revealed that the depth could be reduced to 30 mm and still record the position of the MTJ. The probe frequency was set to 8 MHz and the sampling frequency at 28 Hz. This sampling frequency resulted in a maximum duration of 27 s to be recorded, ensuring adequate recording time for each trial. When the MTJ had been located, a strip of hypoechoic zinc oxide tape was placed over the skin, the probe was then placed over the tape to image the MTJ relative to the tape (appearing as a black line on the ultrasound image; see Figure 3.3.12). To ensure consistent and accurate imaging of the MTJ, the probe was orientated with the proximal end towards the origin of the medial head and the distal end positioned towards the insertion of the tendon. The probe was positioned perpendicularly to the skin and then manipulated until the deep aponeurosis between GM and Sol could be visualised (see Figure 3.3.12). This gave a clear image of the separation of the GM and Sol muscles, tapering of the GM muscle and termination of the GM muscle fascicles into the GM-Achilles MTJ; the probe was then affixed with zinc-oxide adhesive tape in this position.

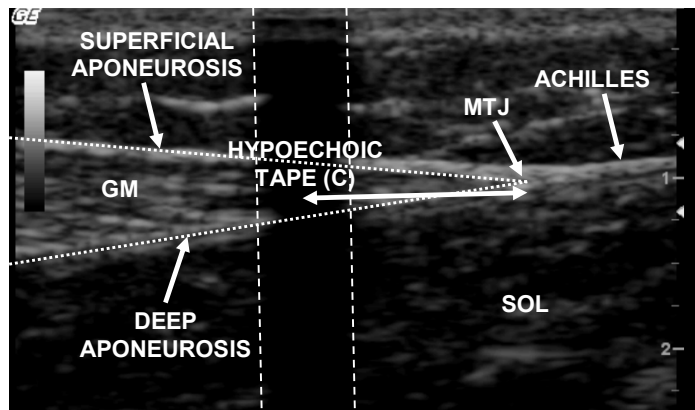

Figure 3.3.12. Ultrasound image of gastrocnemius medialis (GM)-Achilles tendon junction.

Achilles tendon length was calculated by subtracting the distance from the MTJ to the hypoechoic area on the ultrasound image (see Figure 3.3.12; hypoechoic tape aligned with *marker C* in Figure 3.3.8) from the distance between the reflective markers positioned over the hypoechoic tape (*marker C*) and insertion of the Achilles on the calcaneus (see Figure 3.3.8; *marker A*). Gastrocnemius medialis (GM) muscle length was calculated by adding the distance from the MTJ to the hypoechoic area on the ultrasound image (hypoechoic tape; aligned with *marker C*) to the distance between the reflective markers positioned over the hypoechoic tape (*marker C*) and origin of the GM muscle on the medial femoral epicondyle (see Figure 3.3.8; *marker B*).

After the trial was completed, the tester depressed a footswitch (General Electric), which delivered a 5V transistor-transistor linear (TTL) pulse to the ultrasound system and captured the previous 27 s of data. The TTL pulse was simultaneously exported to a data acquisition unit (model MP150 Data Acquisition, Biopac), which was then directed to a personal computer running AcqKnowledge software (v3.8.2, Biopac). The last image recorded on the ultrasound was indicative of the same point in time as the TTL pulse captured on the AcqKnowledge trace. This method enabled ultrasound data to be synchronised with dynamometer, EMG and motion analysis data (see Figure 3.3.13). A time-line regression to a specific ROM could then be determined using the TTL marker on the AcqKnowledge trace and the last image on the ultrasound recording.

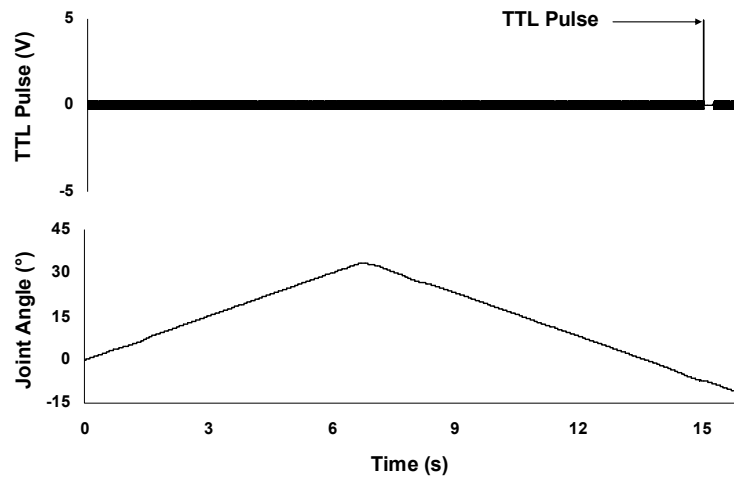

Figure 3.3.13. Transistor-transistor linear (TTL) pulse and joint angle synchronisation.

The positions of the GM-MTJ and the hypoechoic tape from the ultrasound clip from a participant's passive trial were manually digitised at 28Hz (Peak Motus, US) and the raw coordinate data were then filtered with a Butterworth 3 Hz low pass filter. Every fifth frame (4.67Hz) from the same trial was then digitised and the accuracy of this method was determined by comparing the distances calculated at 10%, 30%, 50%, 70% and 90% of ROM during a trial sampled at 28 Hz. As can be seen from Table 3.3.1, distances were calculated from the ultrasound images prior to, and subsequent from, the required delta time (indicative of a ROM of interest). Finally, a linear regression from these two time indices was used to enable tendon excursion to be calculated.

Table 3.3.1. Linear regression calculations for ultrasound data sampled at 4.67 Hz.

MEASURE	ROM (%)				
	10	30	50	70	90
Required Time (s)	-14.48	-13.16	-11.85	-10.54	-9.21
Previous Time (s)	-14.57	-13.29	-12.00	-10.71	-9.21
Subsequent Time (s)	-14.36	-13.07	-11.79	-10.50	-9.00
Previous Distance (mm)	3.31	8.83	14.86	19.95	25.03
Subsequent Distance (mm)	3.99	9.88	15.66	20.86	25.70
Delta Time (s)	0.21	0.21	0.21	0.21	0.21
Relative Projected Time (s)	0.09	0.13	0.15	0.17	0.00
Relative Projected Time (%)	0.43	0.59	0.70	0.81	0.02
Delta Distance (mm)	0.68	1.05	0.80	0.91	0.67
Relative Projected Distance (mm)	0.29	0.62	0.56	0.74	0.01
Actual Projected Distance (mm)	3.60	9.44	15.42	20.69	25.04
Original Distance (mm) using 28 Hz	3.82	9.46	15.37	20.61	25.04

As can be seen from Table 3.3.1, the average difference between the two digitising methods was calculated at less than one tenth of a millimetre, therefore, the 4.67 Hz (5 frame skipping) method was employed to digitise the ultrasound images as it proved to be as accurate as the

original 28 Hz digitising method (see Figure 3.3.14) but substantially reduced the time necessary to digitise the ultrasound trials.

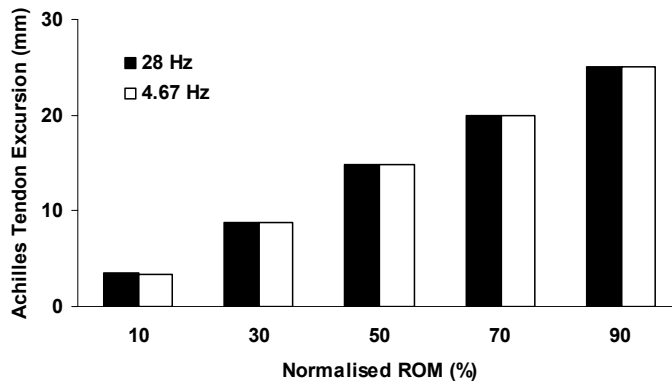

Figure 3.3.14. Achilles tendon excursion during one passive trial at 28 Hz and 4.67 Hz calculated at 10%, 30%, 50%, 70% and 90% of ROM.

One tester digitised all ultrasound images thereby removing inter-tester variability from impacting upon the reliability of the digitising process. In pilot testing, real-time ultrasound imaging of the displacement of the MTJ was captured on five participants to determine the reliability of the manual digitising process. The positions of the MTJ and hypoechoic tape during a passive trial were manually digitised, and this process was repeated after 30 min. The data were then exported to a spreadsheet where a linear regression was used to calculate the distance between the MTJ and hypoechoic tape at 10%, 30%, 50% 70% and 90% of the ROM. The intraclass correlation coefficients (ICC) were calculated between the trials at 10%, 30%, 50% 70% and 90% of the ROM, which ranged from 0.98 to 0.99 indicating very high reliability of the digitising process throughout the ROM. Coefficients of variation (expressed as a percentage of the mean) ranged from 0.3% to 0.4%, again indicating the high reliability of the process. No significant difference was detected between mean values ($P > 0.05$) for the test re-test groups (see Figure 3.3.15).

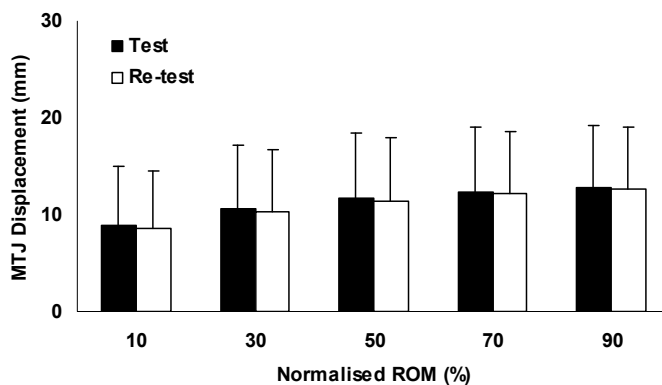

Figure 3.3.15. Intra-tester digitisation reliability of muscle-tendon junction (MTJ) displacement measured at 10%, 30%, 50%, 70% and 90% of ROM.

Ultrasound, motion analysis, and dynamometer data were synchronised using a 5-V ascending TTL pulse that was exported to the AcqKnowledge (v3.8.2) software and triggered the capture of ultrasound data. A time-line regression to a specific ROM was then determined using the TTL marker on the AcqKnowledge trace and the last image on the ultrasound recording. Using this synchronisation process tendon length could be calculated at any chosen joint angle using the distance between reflective markers A (Achilles insertion) and C (marker aligned with hypoechoic tape over estimated MTJ position) (determined with motion analysis), minus the distance from the actual MTJ position (determined with ultrasound) to the hypoechoic tape (appearing as a black line on the ultrasound image; see Figure 3.3.12). Similarly GM muscle length was calculated as the distance between reflective markers B (GM origin on the medial femoral epicondyle) and C, plus the distance from actual MTJ position to the hypoechoic tape; similar to a method used by Arampatzis et al. (2004) for measuring tendon and aponeurosis elongation. Tendon stiffness was calculated by dividing tendon length change by the change in ankle moment during concentric trials. Moment arms were not determined in the present study since it was non-changing and would not have influenced the results; thus, tendon 'force' (joint moment per moment arm) was not derived.

3.3.16. Data Analysis

All data were analysed using SPSS statistical software (v.11.5; LEAD Technologies Inc., USA); group data are reported as means \pm SE and temporal (i.e. change) data are reported as means \pm SD. All data were initially screened to test for assumptions of normal distribution using Kolmogorov-Smirnov and Shapiro-Wilks, which revealed no significant difference ($P > 0.05$) and thus indicate that the data were normally distributed. Where Mauchly's test of sphericity revealed no significant differences ($P > 0.05$), the sphericity assumed F ratio was used to determine significant differences between groups. Where sphericity was violated ($P < 0.05$), the Greenhouse-Geisser value was used to measure the F ratio to determine significance. Multiple analyses of variance (MANOVA) with repeated measures were used to test for differences in EMG mean and median frequencies. Separate analyses of variance (ANOVA) with repeated measures were used to test for differences in 1) concentric and passive plantarflexor moment, 2) EMG amplitude and EMG:moment ratio, and 3) GM muscle and Achilles tendon lengths and tendon stiffness. Pearson's product moment correlation was used to determine the relationship between post-stretch reductions in moment and changes in EMG amplitude. Consistent with statistical procedures (Field, 2005), Bonferroni correction was applied during post hoc analysis, where this proved too conservative (masked the location of the difference), Tukey's LSD was applied (specific correction used is reported with each data set). Statistical significance for all tests was accepted at $P < 0.05$.

3.4. Results

The current study included two trials, an experimental (stretch) condition and a control (no stretch) condition. For clarity, given the number of analyses undertaken, the results have been separated into sections devoted to each trial and measure.

3.4.1. Changes in concentric and passive joint moment, TS EMG, GM muscle length and Achilles tendon length and stiffness with 5-min passive rest (control condition).

No significant change was detected during the control condition in concentric or passive joint moment, EMG, tendon or muscle length and tendon stiffness after 5 min of rest ($P > 0.05$; see Figure 3.4.1).

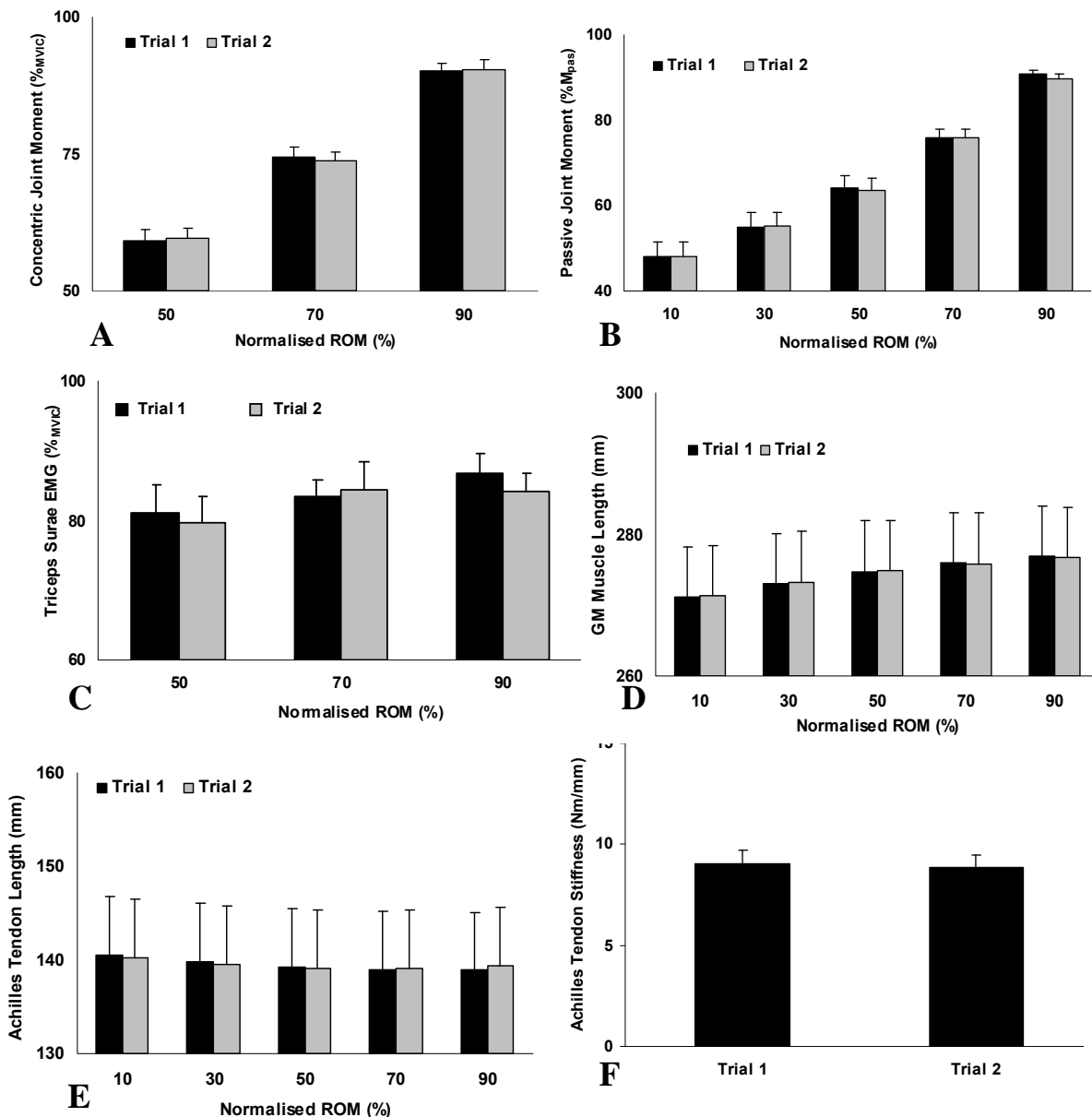

Figure 3.4.1. Concentric (A) and passive plantarflexor joint moment (B), triceps surae (TS) EMG (C), gastrocnemius medialis (GM) muscle length (D), Achilles tendon length (E) and stiffness (F) within the no stretch (control) condition at 10%, 30%, 50%, 70% and 90% of ROM. M_{pas} - percentage of maximal joint moment recorded during passive trial.

Test-retest reliability analyses within the control condition for concentric moment, TS EMG, passive moment, muscle length and tendon length and tendon stiffness revealed very high ICCs (see Table 3.4.1) and very low CVs (expressed as the standard deviation as a percentage of the mean) at each ROM for concentric and passive joint moment, TS EMG and Achilles tendon length and GM muscle length. Consistently small CVs were calculated for all measures through ROM within the control condition (see Table 3.4.1). Increasing coefficients were detected in passive joint moment at 30% and 10% of ROM (3.5% and 5.3% respectively), which may impact the ability to detect changes in joint moment at these specific ROM. Therefore caution needs to be taken at these joint angles when determining the reliability of any experimental post-stretch passive moment data.

Table 3.4.1. Intraclass correlation coefficients (ICCs) & coefficients of variation (CVs) for concentric and passive joint moment, TS EMG, Achilles tendon length and stiffness and gastrocnemius medialis (GM) muscle length within the no stretch (control) condition.

Source	ROM (%)	ICC	CV
Concentric Moment	90	0.85	2.3
	70	0.90	2.3
	50	0.79	3.2
TS EMG	90	0.91	4.4
	70	0.78	5.2
	50	0.89	6.4
Passive Moment	90	0.83	2.0
	70	0.96	1.8
	50	0.99	1.9
	30	0.98	3.5
	10	0.97	5.3
Achilles Tendon Length	90	1.0	0.4
	70	1.0	0.4
	50	1.0	0.4
	30	1.0	0.5
	10	1.0	0.4
GM Muscle Length	90	1.0	0.2
	70	1.0	0.2
	50	1.0	0.2
	30	1.0	0.2
	10	1.0	0.2
Achilles Tendon Stiffness	90	0.94	4.7

3.4.2. Changes in concentric joint moment with 3-min of passive stretch (hypothesis 1)

There was a significant reduction in peak concentric moment measured at 50% ($F = 4.14$; $P < 0.05$), 70% ($F = 3.71$; $P < 0.05$) and 90% ($F = 5.63$; $P < 0.01$) of ROM (see Appendix 3; Table 3.4.2). Although an ANOVA revealed significant reductions in joint moment, no significant difference could be detected when Bonferroni correction was employed during post-hoc analyses at 50% and 70% of ROM, which suggests they were too conservative and were masking the location of the effect originally detected (Field, 2005). ANOVA is a more robust analysis than using several t-tests and is employed to reduce the likelihood of making a type I error. However, if a significant difference is detected during ANOVA, post hoc analysis should be able to detect where this difference exists. Therefore, to reduce the risk of making a type II error, Tukey's LSD was applied during the post-hoc analysis (no correction). These tests revealed significant reductions in concentric moment (mean = $5.0 \pm 0.3\%$; $P < 0.05$) existed immediately post-stretch when compared to pre-stretch values at all joint angles (see Figure 3.4.2). No significant differences were detected at any ROM after 30 min of rest although mean data revealed only 60% of the stretch-induced reductions had returned.

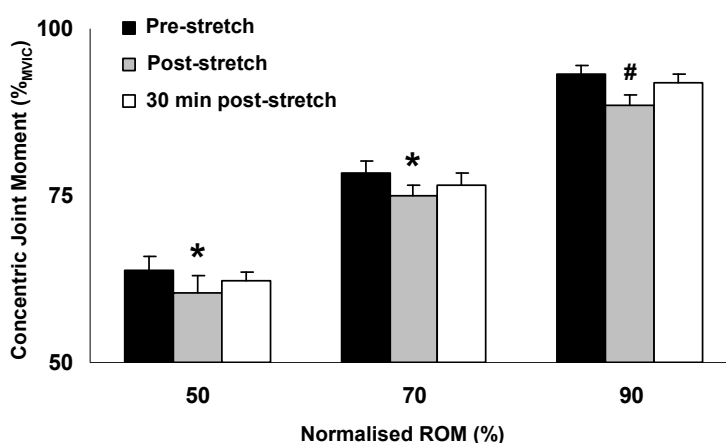

Figure 3.4.2. Concentric joint moment during active plantarflexion trials. Significant decreases were detected at 50%, 70% and 90% of ROM after stretch. *Significant to $P < 0.05$; #significant to $P < 0.01$.

3.4.3. Changes in EMG with 3-min of passive stretch (hypothesis 1)

There was a significant reduction in peak EMG amplitude in GL measured at 70% ($F = 5.42$; $P < 0.05$) and 90% ($F = 5.42$; $P < 0.01$) of ROM, statistical significance was almost reached at 50% ($F = 2.78$; $P = 0.08$). In GM a significant reduction was revealed at 50% of ROM ($F = 3.60$; $P < 0.05$), statistical significance was almost obtained at 90% ($F = 2.88$; $P = 0.07$). In Sol a significant reduction was revealed at 90% ($F = 9.93$; $P < 0.01$). Finally, in triceps surae (TS) activity (mean EMG in GL, GM and Sol), a significant reduction (see Appendix 3; Table 3.4.3) was revealed at 90% ($F = 9.44$; $P < 0.05$) of ROM, and statistical significance was almost reached at 50% ($P = 0.053$) and 70% ($P = 0.066$) of ROM with effect sizes of 0.62 and 0.46 respectively. Thus, there was a reduction in TS EMG activity post-stretch. No change in TA

EMG amplitude (mean pre-stretch = $11.3 \pm 0.7\%$, mean post-stretch = $11.3 \pm 0.4\%$ $P > 0.05$) was detected, suggesting that the stretch intervention did not impact neuromuscular coactivity. There was also no change in the TS EMG:moment ratio (mean pre-stretch = 1.2:1, mean post-stretch = 1.2:1; $P > 0.05$) or in the mean (pre-stretch = 215.0 ± 6.6 Hz, post-stretch = 212.8 ± 5.8 Hz; $P > 0.05$, TS EMG) or the median (pre-stretch = 117.1 ± 5.4 Hz, post-stretch = 114.8 ± 4.8 Hz; $P > 0.05$, TS EMG) frequency of any EMG signal.

Post-hoc t-test analyses with Bonferroni correction revealed a significant reduction in EMG amplitude after the stretch and a significant increase after 30 min of rest to, or above, pre-stretch levels (see Figure 3.4.3). Although statistical significance was not reached in all muscle EMG signals at all joint angles, a consistent trend towards reductions in mean EMG amplitude 2 min post-stretch, followed by full recovery 30 min post-stretch within all three plantarflexor muscles and TS EMG, were noticed; effect sizes were moderate to large. This indicates that muscle activity was reduced at 2 min post-stretch but fully recovered by 30 min.

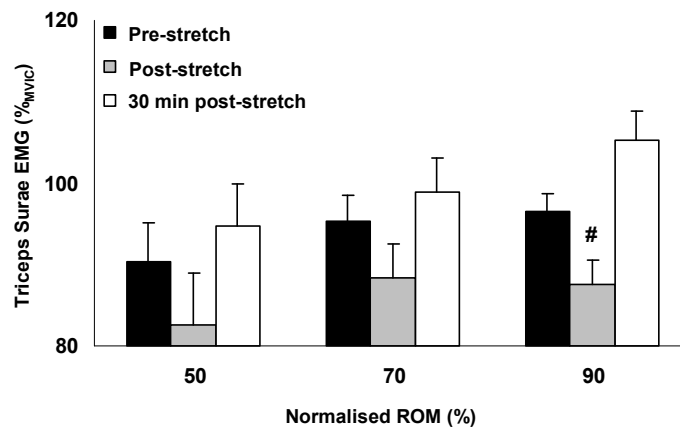

Figure 3.4.3. Triceps surae (TS) electromyographic (EMG) amplitude during maximal concentric plantarflexion within the stretch condition measured at 50%, 70% and 90% of ROM. #Significant to $P < 0.01$ compared to pre-stretch group.

3.4.4. EMG:Moment correlation (hypothesis 2)

The Pearson's product moment correlations computed between decreases in concentric joint moment and changes in EMG amplitude revealed significant correlations with GL EMG at 50% ($r = 0.58$; $P < 0.05$) and 70% ($r = 0.69$; $P < 0.01$) of ROM, with GM EMG at 50% ($r = 0.73$; $P < 0.01$) and 70% ($r = 0.56$; $P < 0.05$) of ROM, and with Sol EMG at 50% ($r = 0.81$; $P < 0.01$) of ROM. However, the strongest correlations were seen in triceps surae EMG at 50% ($r = 0.81$; $P < 0.01$) and 70% ($r = 0.65$; $P < 0.05$) of ROM. This suggests that averaging of the individual EMG signals to create a single EMG, representative of the muscle group activation, produced stronger relationships and indicated that the participants who had the greater reductions in EMG tended also to exhibit the greatest loss of active joint moment (see Figure 3.4.4).

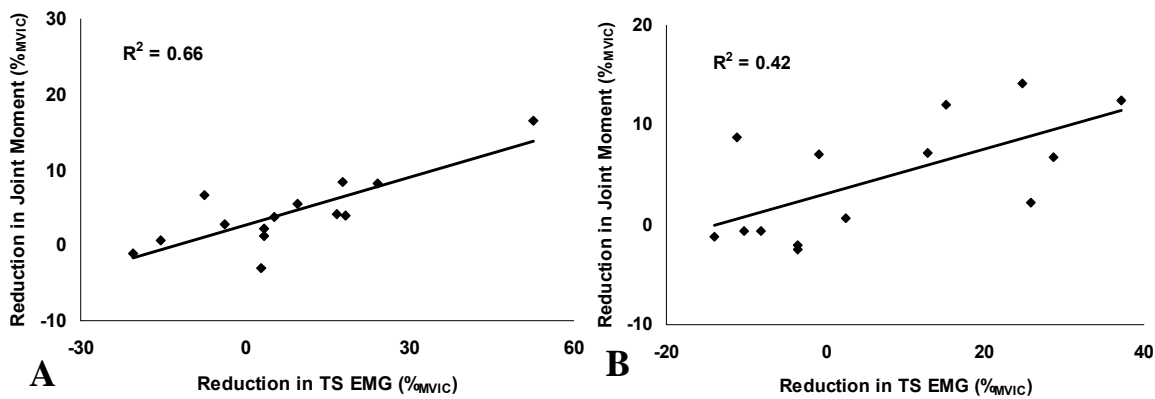

Figure 3.4.4. Correlations between post-stretch reductions in concentric joint moment and triceps surae (TS) electromyographic (EMG) amplitude (A = 50%; B = 70% of ROM).

3.4.5. Changes in passive joint moment with 3-min of passive stretch (hypothesis 1)

There was a significant decrease in passive joint moment measured at 50% ($F = 4.21$; $P < 0.05$), 70% ($F = 5.90$; $P < 0.01$) and 90% ($F = 4.31$; $P < 0.05$) of ROM but no significant difference was detected at 10% or 30% of ROM ($P > 0.05$) (see Appendix 3; Table 3.4.4). Post hoc t-test analyses with Tukey's LSD correction revealed a significant reduction in joint moment (mean = $5.1 \pm 1.6\%$) immediately after stretch at 50%, 70% and 90% of ROM (see Figure 3.4.5), and a subsequent, significant increase 30 min later such that passive joint moment was no longer significantly reduced when compared to the pre-stretch group (mean = $0.6 \pm 0.5\%$; $P > 0.05$).

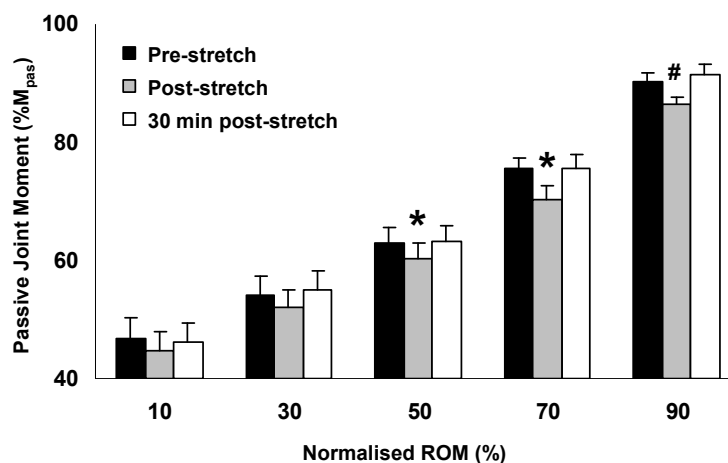

Figure 3.4.5. Moment during passive dorsiflexion trials within the stretch condition measured at 10%, 30%, 50%, 70% and 90% of ROM. *Significant to $P < 0.05$; #significant to $P < 0.01$ compared to baseline.

3.4.6. Changes in Achilles tendon length and stiffness and GM muscle length with 3-min of passive stretch (hypothesis 3)

During the concentric trials there was a significant reduction in tendon length at 50% ($F = 5.55$; $P < 0.05$), 70% ($F = 4.95$; $P < 0.05$) and 90% ($F = 5.35$; $P < 0.05$) of ROM and an increase in muscle operating length at 50% ($F = 5.55$; $P < 0.05$), 70% ($F = 4.95$; $P < 0.05$) and 90% ($F = 5.35$; $P < 0.05$) of ROM (see Appendix 3; Table 3.4.5). No significant difference was detected in tendon stiffness (11.7 ± 1.3 Nm/mm pre-stretch to 12.2 ± 1.5 Nm/mm post-stretch; $P > 0.05$). Post-hoc t-test analyses with Tukey's LSD correction revealed a reduction in tendon length (mean = $1.4 \pm 0.1\%$; $P < 0.05$) and an increase in muscle operating length (mean = $1.0 \pm 0.1\%$; $P < 0.05$) immediately post-stretch when compared to the pre-stretch group, which remained apparent 30 min post-stretch when compared to pre-stretch data (see Figure 3.4.6).

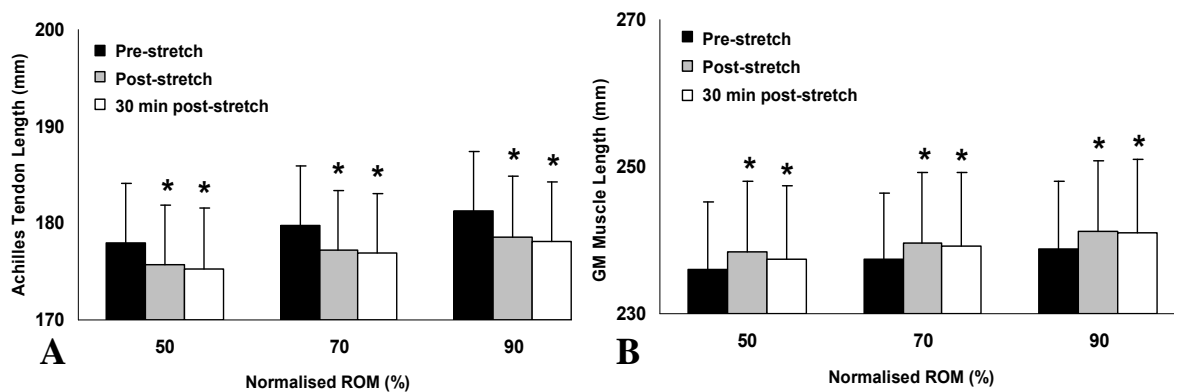

Figure 3.4.6. Achilles tendon length (A) and gastrocnemius medialis (GM) muscle length (B) during maximal concentric plantarflexion trials measured at 50%, 70% and 90% of ROM. *Significant to $P < 0.05$ compared to baseline.

During the passive trials no significant difference ($P > 0.05$) was observed in Achilles tendon or GM muscle length (see Appendix 3; Table 3.4.6), although a consistent trend at all joint angles indicating longer GM muscle and shorter Achilles tendon length was apparent (see Figure 3.4.7).

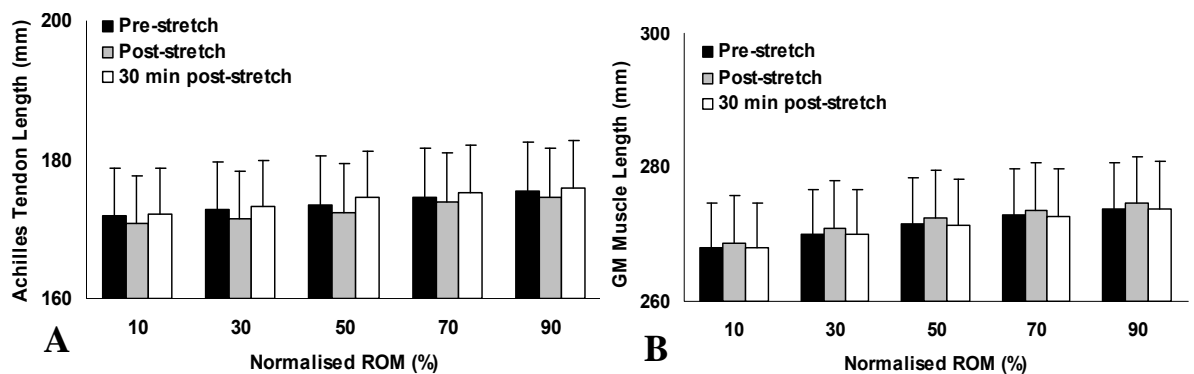

Figure 3.4.7. Achilles tendon (A) and gastrocnemius medialis (GM) muscle length (B) during passive dorsiflexion trials measured at 10%, 30%, 50%, 70% and 90% of ROM.

3.5. Discussion

The aims of the current study were threefold: 1) to determine the effects of moderate-duration acute static stretching on passive and active plantarflexor joint moment, 2) to establish whether any changes were immediate (2 min post-stretch) or residual (30 min post-stretch), and 3) to clarify possible mechanisms related to these potential moment losses. Related to these aims there were three major findings. First, there were significant reductions in peak concentric joint moment measured at 50%, 70% and 90% of ROM after stretch (mean = $5.0 \pm 0.3\%$). This was accompanied by, and correlated with ($r = 0.81$; $P < 0.01$), significant reductions in EMG amplitude (mean = $8.3 \pm 1.0\%$); concentric moment partially recovered ($59.0 \pm 12.6\%$) whilst EMG fully recovered after 30 min of rest. This indicates that the reductions in joint moment were largely attributable to reduced muscle activity. Second, Achilles tendon length during the concentric contractions measured at 50%, 70% and 90% of ROM was significantly reduced post-stretch (mean = $1.4 \pm 0.1\%$) and GM muscle operating length was significantly increased (mean = $1.0 \pm 0.1\%$); however, there was no significant change in tendon stiffness. This indicates that the reduced tendon length resulted from a decrease in muscle force and the change in muscle operating length was not the cause of the reduction in joint moment as it operated closer to the plateau of its force-length curve. Third, there was a significant decrease in passive joint moment post-stretch at 50%, 70% and 90% of ROM (mean = $5.1 \pm 1.6\%$). This was accompanied by a trend towards increased muscle length (indicating a reduction in GM muscle stiffness) but there was no detectable change in tendon stiffness and passive joint moment returned to baseline levels after 30 min. The lack of change in tendon stiffness is indicative of the reductions in passive joint moment being largely attributable to changes in muscle stiffness. Despite these changes being seen at the most dorsiflexed joint positions, there were no detectable reductions in passive joint moment, Achilles tendon stiffness, GM muscle length or Achilles tendon length during the passive trials at 10% or 30% of ROM. Given these findings the first hypothesis that there was a significantly reduced active and passive plantarflexor moment and EMG post-stretch can be partially accepted. The second hypothesis that losses in concentric moment and EMG would be significantly correlated can be accepted. Finally, the third hypothesis that there would be a significant decrease in tendon stiffness and increase in tendon length post-stretch can be rejected.

The significant reductions ($P < 0.05$) in concentric plantarflexor moment and peak EMG amplitude through a range of joint angles (50%, 70% and 90%) are consistent with previous reports of decreases in muscle force and EMG amplitude after acute periods of static stretch (Avela et al., 1999, 2004; Behm et al., 2001; Brandenburg, 2006; Cornwell et al., 2002; Cramer et al., 2004, 2007; Fowles et al., 2000; Knudson & Noffal, 2005; Nelson et al., 2001a, 2001b, Weir et al., 2005). In fact, peak plantarflexor joint moment and EMG amplitude were well correlated in all three muscle EMG amplitudes, which is indicative of a consistent impact across muscles and reduced muscle activity being partly responsible for the losses in force production; over 65% of the variability in moment changes can be explained by the changes in EMG amplitude. In the present study the three EMG amplitudes (GL, GM, Sol) were averaged to create a single EMG amplitude, representative of the triceps surae muscle group EMG activity.

Interestingly, this process revealed stronger correlations with moment decreases ($r = 0.81$; $P < 0.01$) than those computed for individual muscle EMG amplitudes. Whilst pilot testing showed that all three triceps surae muscles had a strong linear relationship with joint moment during a ramped contraction (75 - 100%_{MVIC}), EMG amplitude tended to fluctuate when maximal joint moment was achieved, possibly due to the cyclic turnover of motor units in this high contractile state (Taylor et al., 2000b) or changes to motor unit firing rate (Morimoto & Masuda, 1984). The relatively short averaging window (250 ms) of the RMS EMG necessary to ensure muscle activity was representative of the specific joint moment at a given joint angle (i.e. minimised time shift) increased the variability of the EMG signal. Averaging the signals from all three muscles to create a single EMG amplitude representative of the muscle group reduced the variability of the signal during this maximal contractile state (Cifrek et al., 2009). Thus, averaging individual muscle EMG to create muscle group EMG may enable a more accurate reflection of the EMG-moment relationship, and could be an important methodological consideration for future research using EMG analysis as an indicator of muscle force production during maximal contractions.

While the present study clearly indicates a significant stretch-induced reduction in neuromuscular activity (EMG), the mechanisms underpinning these reductions remain unclear. Gandevia (1992) suggested a reduced central neural drive inhibiting activation of the α -motoneurone pool might be responsible, while Avela et al. (1999) suggested that there was a peripheral component; either disfacilitation of the α -motoneurone pool from reduced excitatory group Ia or group II muscle afferent output, or inhibition of the α -motoneurone pool from increased inhibitory group Ib, III and IV muscle afferent output. Avela et al. (1999) reported post-stretch reductions in maximal triceps surae moment, EMG, and Hoffmann (H)-reflexes in conjunction with increased MTC compliance. The authors speculated that increased muscle compliance may have reduced resting neural discharge of the muscle spindles (group Ia afferents). This contention is supported by the observed reduction in H-reflexes, thus lowering overall excitatory input to the α -motoneurone pool resulting in reduced EMG amplitude and joint moment. In the present study, evidence for a post-stretch reduction in GM muscle stiffness was also found in conjunction with reduced EMG and active joint moment. There was an absence of evidence of a change in tendon stiffness, which limits the likelihood of inhibition from golgi tendon organs (group Ib afferents) being a significant factor influencing the reduction in EMG. However, a decreased muscle stiffness would support the conclusions of Avela et al. (1999), that disfacilitation of the α -motoneurone pool from a reduced excitatory input from group Ia muscle afferents might influence neuromuscular activity. Nonetheless, the focus of the present study was to determine whether moderate-duration stretching compromised neuromuscular activity and whether any reductions were correlated with force deficits, rather than the mechanisms underpinning any reduction in EMG. Thus, the factors influencing the changes in EMG amplitude cannot be determined from the present data.

The 5% post-stretch force decrease seen in the present study is less than that reported previously (7-23%; Avela et al., 2001, 2004; Fowles et al., 2000; McHugh & Nesse, 2008; Viale

et al., 2007; Weir et al., 2005). One difference between this study and others is that a shorter stretch duration was imposed presently, which may have limited the force losses according to the well-established dose-response relationship (Kay & Blazevich, 2008; Knudson & Noffal, 2005; Ogura et al., 2007; Ryan et al., 2008; Siatras et al., 2008; Young et al., 2006). Interestingly, the significant reduction in force was not present after 30 min of passive rest ($59.0 \pm 12.6\%$ recovery) with EMG fully recovering to, or slightly above, pre-stretch levels. Fowles et al. (2000) reported similar recovery patterns after 30 min of passive rest (43% recovery in joint moment; full recovery in EMG). These different temporal responses of muscle force and EMG, where partial recovery of active plantarflexor moment but full recovery in EMG (30 min) is apparent, are suggestive that a mechanism other than decreases in neuromuscular activity may be partly responsible for force losses. While alterations in muscle and tendon stiffness have been hypothesised to contribute to the stretch-induced force losses (Cramer et al., 2004, 2007; Fowles et al., 2000; Kay & Blazevich, 2008; Nelson et al., 2001a, 2001b, Weir et al., 2005), to the authors knowledge, no studies had previously measured muscle or tendon length changes post-stretch to determine whether a reduction in tendon stiffness would result in the muscle operating at a shorter length. This could decrease muscle force at a given joint angle for the plantarflexors, as the leftward shift in its force-length curve would cause it to operate further down its ascending limb (Maganaris, 2001, 2003). However, the second main finding of the present study was that there was no evidence for a change in tendon stiffness after stretch. Furthermore, tendon elongation was significantly reduced and GM muscle length was significantly increased, when measured during the concentric contraction, and occurred simultaneously with a reduced joint moment. Thus the muscle operated at a longer, and presumably stronger, length after stretch, yet force production was reduced. The findings of a lack of change in tendon stiffness are consistent with that of Morse et al. (2008), who found no change in tendon stiffness following 5 min stretch, but are not in agreement with Kubo et al. (2001a), who reported decreases in tendon stiffness after 10 min of stretch. These differing results might indicate a dose-response effect of stretch on changes to tendon stiffness or may be reflective of different methods of measuring tendon stiffness (e.g. Morse et al. measured tendon elongation at the MTJ, whereas Kubo et al. measured at the fascicle insertion onto the deep aponeurosis).

The present data are the first to show that altered tendon stiffness impacting muscle operating length is not a mechanism underpinning the force deficits after moderate-duration stretch. Given that a decrease in muscle force was not caused by changes in muscle operating length, that it cannot be fully explained by decreases in EMG and that there was a clear change in muscle mechanical properties, one can speculate that a muscle-based mechanism, possibly affecting the excitation-contraction (EC) coupling process, may be partly responsible for these force deficits. The EC coupling process could be impaired due to microtrauma to the cytoskeleton of the muscle fibre such as damage to the sarcoplasmic reticulum (Bruton et al., 1996; Lamb et al., 1995) or transverse-tubular disruption (Yeung et al., 2002), which may affect the transmission of action potentials and subsequent calcium ion (Ca^{2+}) release from the lateral sacs of the sarcoplasmic reticulum. While this level of cytoskeletal muscle fibre damage was

observed following eccentric contractions and has not yet been observed following passive stretch, Armstrong et al. (1993) have reported post-stretch elevations in muscle Ca^{2+} concentration associated with reduced force production, supporting the contention of a muscle based mechanism partly responsible for stretch-induced force deficits. Furthermore, the reduced passive moment and reduced muscle stiffness may indicate some level of microtrauma to the muscle tissue. However, this remains speculative and further research is required to determine whether a muscle based component is associated with stretch-induced force deficits.

The consistent post-stretch reduction in concentric plantarflexor joint moment at several joint angles (50%, 70% & 90%) indicates that the effect was not joint angle (muscle length) specific. This finding is in contrast with McHugh & Nesse (2008) who reported a muscle length-dependent effect of stretch with greater reductions in isometric force at shorter muscle lengths (17%) than longer lengths (8%) within the knee flexors. However, significant differences in study design including muscle group, contraction mode and ROM do not allow a clear comparison of results; thus, determination of the importance of muscle length to the effects of static stretch on force production cannot be made. Nonetheless, closer inspection of McHugh & Nesse's (2008) data revealed that force losses were very similar (5% at 50°, 7% at 35°, and 8% at 20°; mean = $6.7 \pm 1.5\%$) at three of the longer muscle lengths, with significantly greater reductions only apparent at the shortest length (17% at 80°). The current study tested concentric moment at a slow velocity ($0.087 \text{ rad}\cdot\text{s}^{-1}$) resulting in a contraction time of over 12 s. With concerns over fatigue impacting the results, and the importance to performance of greater propulsive forces during locomotion occurring in a dorsiflexed position, moment data were only analysed in the early stages of ROM (50%, 70% & 90%). These joint angles placed the plantarflexors in a lengthened position and are therefore consistent with the findings of McHugh & Nesse (2008). However, as the present study did not examine the effects of stretch in a more plantarflexed position, which would have shortened the muscle considerably, a possible muscle length component impacting force deficits within the plantarflexors cannot be eliminated.

The third main finding of the present study was the significant reduction in passive moment. Given that no change in tendon stiffness was detected, the reduction in passive stiffness is likely attributable to a reduction in muscle stiffness. The reductions in passive moment are consistent with those reported by others where stretch-duration exceeded 5 min (Kubo et al., 2001a; Magnusson et al., 1996c) and those of Morse et al. (2008) who reported similar decrements in passive joint moment accompanied by reduced muscle stiffness but unaltered tendon stiffness. However, studies imposing shorter durations of stretch at 90-135 s have reported no change in passive joint moment (Magnusson et al., 1998, 2000). Collectively, these findings are indicative of a dose-response, where only longer durations of stretch (>3 min) consistently reduce passive moment. Passive joint moment, when measured using isokinetic dynamometry, is the sum of the stiffness of muscle and tendon tissues, stiffness of various structures within the joint capsule, mass of the foot and dynamometer footplate, and the resistance generated by the footplate's Velcro strapping. Several of these parameters are fixed factors (mass of the foot and dynamometer footplate, Velcro strapping) and therefore could not

account for changes seen in passive joint moment. Furthermore, in the present study no evidence for a change in tendon stiffness was found, indicating that changes in muscle or joint stiffness were responsible for the reductions in passive joint moment. Unfortunately, the stiffness of joint structures could not be calculated in the present study, and therefore their contribution and possible change post-stretch could also not be determined. In agreement with the data from the present study, Morse et al. (2008) also reported post-stretch reductions in passive joint moment with no change in tendon stiffness. Given their finding of a non-significant change in muscle length despite a reduced passive joint moment, the reductions in passive joint moment were also attributed to decreased muscle stiffness. However, further research is required to clarify the impact to specific tissues imposed by stretch.

While the duration of stretch may be an important consideration when considering passive moment and mechanical properties of the MTC, an interesting finding in the present study was that no significant reductions were observed in passive joint moment at 10% or 30% of ROM. This might be due to the lesser reliability of passive joint moment measurement (measured in the control condition) being lower at these joint angles; coefficients of variance increased from 1.9% at 50% of ROM to 5.3% at 10% of ROM. Under these conditions statistical significance may be more difficult to detect. Alternatively, the data might indicate that the effects of stretch are muscle-length dependent, with decreases occurring only at longer lengths. The measurement of joint moment at several joint angles and the determination of the inflection point may be important methodological considerations, as analysis of passive joint moment at plantarflexed ROMs (i.e. below the inflection point) could produce unreliable data and mask the effects of stretch. Consistent with this contention, Muir et al. (1999) reported no significant change in passive moment measured at 10° of dorsiflexion and at 0° (anatomical position) following 120 s of static stretch. According to the present study protocol, this would have placed the participants' ankles either close to, or below the ROM for the inflection point calculated within the present study (mean = $0.8 \pm 4.8^\circ$ dorsiflexion), and certainly not at or above 50% of normalised ROM calculated from the inflection point to volitional end ROM. Therefore, while Muir et al. (1999) reported no effects of stretch to passive joint moment, their methodology may have not allowed a real effect of stretch to be seen at ankle ROMs of greater dorsiflexion, where the plantarflexors are under significantly greater stress and passive joint moment data are more reliable.

In summary, the present study is the first to specifically compare the effects of stretch on both active and passive joint moment through a range of joint angles, including analysis of neuromuscular and mechanical mechanisms that are implicated with stretch-induced force deficits. Consistent with much of the current literature, the results showed significant reductions in active joint moment and EMG amplitude post-stretch. Importantly however, significant correlations between reductions in peak concentric moment with reduced muscle EMG amplitude were also found in the present study. This indicates that a significant proportion of the reduction in force (~65%) can be attributed to reduced muscle activity. Possible reductions in muscle operating length resulting from an increase in tendon compliance were clearly not a

factor. This is an important finding as it substantially narrows the number of mechanisms that might underpin the stretch-induced force deficit phenomenon. Also, since tendon properties are important determinants of movement performance, the lack of change in tendon properties allows us to speculate as to the likely impact of acute stretching on movement performance. Collectively, these data clearly indicate an as yet unidentified mechanism also impacting force production after stretch because changes in neuromuscular activity could not fully explain the force losses. Furthermore, the averaging of individual muscle EMG amplitudes to create an EMG signal representative of triceps surae muscle group activity produced stronger correlations with moment losses and could be an important methodological consideration for future studies. The reduction in passive moment were attributed to reduction in muscle stiffness as tendon stiffness remained unaffected by the stretch, which is in agreement with previous data (Morse et al., 2008) showing that increased ankle joint flexibility can be attributed to increased muscle compliance. With significant reductions in passive moment only apparent in dorsiflexed positions, identification of the inflection point during ROM may also be an important methodological consideration when measuring passive moment and any impact of stretch and should be considered by researchers in future studies. Importantly, no deficits in active and passive joint moment and EMG amplitude were found at 30 min post-stretch, suggesting the effects of these shorter duration stretches (<3 min in total) were transient. Therefore, the performance of physical tasks requiring high levels of plantarflexor muscle force is unlikely to be compromised following moderate duration passive stretch, and the previously reported negative impact of stretch on force production might be of lesser practical importance when tasks are performed at a reasonable time period (~30 min) after the stretch.

Chapter 4

Study 2

Isometric contractions reduce concentric and passive plantarflexor moment, Achilles tendon stiffness and neuromuscular activity but remove the subsequent effects of stretch

4.1. Abstract

The effects of isometric contractions and passive stretching on muscle-tendon mechanics and muscle activity were studied in sixteen healthy human volunteers. First, peak concentric and passive ankle joint moment data were recorded on an isokinetic dynamometer with EMG monitoring of the triceps surae; real-time motion analysis of the lower leg and ultrasound imaging of the Achilles-medial gastrocnemius muscle-tendon junction were simultaneously conducted. The participants then performed six 8-s maximal voluntary isometric contractions (MVICs) before repeating the passive and active trials. Although there was no decrease in isometric joint moment after MVICs, peak concentric moment was significantly reduced (11.5%; $P < 0.01$). This was accompanied by, and correlated with ($r = 0.90$; $P < 0.01$), significant reductions in peak triceps surae EMG amplitude (21.0%; $P < 0.01$). Both Achilles tendon stiffness (10.9%; $P < 0.01$) and passive joint moment (4.9%; $P < 0.01$) were also significantly reduced. Subsequently, the participants performed three 60-s static plantarflexor stretches before being re-tested 2 min and 30 min post-stretch. The stretch protocol caused no significant change in any measure. Thirty minutes after stretching, significant recovery in concentric moment and muscle activity was detected at dorsiflexed joint angles, while Achilles tendon stiffness and passive joint moment remained significantly reduced. These data show that the performance of maximal isometric contractions interrupts the normal stretch-induced losses in active and passive plantarflexor joint moment and neuromuscular activity, largely because concentric strength and tendon properties were already affected. Importantly, the decrease in Achilles tendon stiffness remained 30 min later, which may be an important etiological factor for muscle-tendon strain injury risk.

Keywords: Triceps surae, force deficits, tissue mechanics, electromyography

4.2. Introduction

Pre-performance warm-up routines are commonly promoted and are specifically designed to prepare an individual for high intensity physical activity and to reduce the risk of injury (Bishop, 2003; Woods et al., 2007). The routines typically include cardiovascular work, stretching and strong muscular contractions (with progressing intensity), which promotes increased peripheral blood flow to the working muscle, elevated intramuscular temperature, enhanced neural conduction velocity, increased range of motion (ROM) and decreased viscosity and stiffness of the muscle-tendon complex (MTC) (Agre, 1985; Alter, 1996; Bishop, 2003; Kay & Blazevich, 2008; Kubo et al., 2001a, 2001b; Woods et al., 2007). The stretching routines conducted within the warm-up protocol are employed primarily to increase functional range of motion (ROM) and reduce MTC stiffness in an attempt to reduce injury risk, although their effect in this regard is still debated (Gleim & McHugh, 1997; Thacker et al., 2004; Weldon & Hill, 2003; Witvrouw et al., 2004). The strong muscular isometric contractions have been shown to reduce tendon stiffness (Kubo et al., 2001b) and potentiate muscle force (Baudry & Duchateau, 2007; Hamada et al. 2003; O'Leary et al., 1997), which may optimise neuromuscular activity and force production. Accordingly, some athletes use maximal isometric contractions within their warm-up protocol to potentiate neuromuscular recruitment for optimal performance.

Recently, significant reductions in joint moment and power production have been reported immediately after passive muscle stretching (Behm et al., 2001; Brandenburg, 2006; Cornwell et al., 2002; Cramer et al., 2004, 2005, 2007; Fowles et al., 2000; Kay & Blazevich, 2008; Knudson & Noffal, 2005; Kokkonen et al., 1998; Maisetti et al., 2007; McHugh & Nesse, 2008; Nelson et al., 2001a, 2001b; Ogura et al., 2007; Siatras et al., 2008; Viale et al., 2007; Weir et al., 2005; Young et al., 2006), which is also in agreement with the main findings of the previous study in the present thesis (Chapter 3). Although there are numerous possible mechanisms underpinning the decrease in moment after stretching, two primary mechanisms include: 1) reduced neuromuscular activation (Study 1 data; Avela et al., 1999, 2004, Cramer et al., 2005; Fowles et al., 2000) and 2) altered mechanical properties of muscle-tendon complex (MTC) (Cramer et al., 2004, 2007; Fowles et al., 2000; Kay & Blazevich, 2008; Nelson et al., 2001a, 2001b, Weir et al., 2005). Stretch induced reductions in electromyographic activity (EMG) have been reported concurrently with moment losses after 30 min (Fowles et al., 2000) and 1 hour (Avela et al., 1999) of intermittent static stretching. A novel finding of Study 1 of the present research was that stretch-induced moment deficits within the plantarflexors were strongly correlated with the reductions in triceps surae EMG amplitude (~65% explained variance; $P < 0.01$). However, the changes in active joint moment could not be fully explained by changes in neuromuscular activity so a separate mechanism must be partially responsible for the moment deficits.

Post-stretch reductions in passive moment (Study 1 data; Kay & Blazevich, 2008; Kubo et al., 2001a; Magnusson et al., 1996c, 1998; Morse et al., 2008), indicative of changes in the mechanical properties of the MTC, could impact force generating capacity of important muscle groups such as the triceps surae if there was a decrease in the series stiffness (and in particular

a decrease in tendon stiffness), which would cause these muscles to operate at a shorter, less advantageous length with respect to their force-length relationship (Maganaris, 2001, 2003). Indeed, Kubo et al. (2001a) reported a significant decrease in Achilles tendon stiffness and muscle operating length after 10 min of static plantarflexor stretch, although, interestingly, this was not associated with a reduced isometric force output. In contrast, Morse et al. (2008) reported that shorter duration stretches (< 5 min) did not affect Achilles tendon stiffness, which were in agreement with the findings of Study 1 in the present thesis. Interestingly, Kubo et al. (2001b) reported similar reductions in tendon stiffness to the present study following fifty 3-s isometric contractions, and Maganaris et al. (2006) reported significant reductions in Achilles tendon stiffness following 11 incremental contractions. Collectively, these results suggest that the duration and intensity of tissue strain imposed by either stretching or strong muscular contractions may determine whether changes in tendon stiffness occur. Identifying interventions that alter the mechanical properties of the tendon is important as reduced tendon stiffness may increase neuromechanical delay (Cresswell et al., 1995; Grosset et al., 2009; Kubo et al., 2000), reduce the rate of force development (Bojsen-Møller et al., 2005; Edman & Josephson, 2007; Kubo et al., 2001b) and decrease the active muscle length (Kubo et al., 2001b), which could attenuate maximal force in the human plantarflexors according to its force-length relationship (Maganaris, 2001, 2003). Altered mechanical properties have been hypothesised to contribute to post-stretch reductions in force production (Cramer et al., 2004, 2007; Fowles et al., 2000; Kay & Blazevich, 2008; Nelson et al., 2001a, 2001b, Weir et al., 2005), and given that similar changes in tendon stiffness may be induced by intense contractions (Kubo et al., 2001b; Maganaris et al., 2006), the greater intensity of tissue strain imposed during these contractions may mitigate or remove the effects of subsequent stretch.

Understanding the effects of maximal contractions combined with stretching is important for two reasons. First, it will allow for a more accurate interpretation of results from the literature as some researchers (Behm et al., 2001; Egan et al., 2006; Cornwell et al., 2002; Cramer et al., 2004, 2005; Maisetti et al., 2007; Ryan et al., 2008) but not others (Magnusson et al., 1996c, 1998; Morse et al., 2008) have included maximal isometric contractions in the warm-up or as part of the experimental model prior to testing the effects of static stretch on MTC mechanics, neuromuscular activation and force production. The impact of their inclusion on subsequent stretch-induced force losses and the mechanical or neuromuscular mechanisms associated with these losses has not been directly measured. The inclusion of these contractions may modify MTC mechanics prior to the stretch intervention, which may reverse, mitigate or compound the effects of subsequent stretch. Second, warm-up protocols commonly include both maximal contractions and stretching so examining each activity in isolation does not allow estimation of their combined effects on tendon properties and force production, which may limit the external validity of these studies.

To gain a more comprehensive understanding of the impact of both isometric contractions and static stretch on force production, it is necessary to quantify muscle activity and muscle (or tendon) length changes simultaneously, within a multi-intervention protocol. The present study

aimed first to determine the effects of six 8-s ramped maximal voluntary isometric contractions (MVICs) on Achilles tendon stiffness, gastrocnemius medialis (GM) muscle operating length, active (concentric) and passive plantarflexor joint moment and neuromuscular activity (EMG) of the triceps surae. Second, additional effects of stretch on these measures were quantified 2 min and 30 min post-stretch to determine the influence of these contractions to the well-documented effects of stretch.

Experimental Hypothesis 1

There will be a significant reduction in Achilles tendon stiffness, active and passive plantarflexor moment and EMG magnitude post-isometric contractions

Null Hypothesis 1

There will be no significant reduction in Achilles tendon stiffness, active and passive plantarflexor moment and EMG magnitude post-isometric contractions

Experimental Hypothesis 2

There will be a significant correlation between post-isometric contractions reductions in concentric moment and EMG magnitude

Null Hypothesis 2

There will be no significant correlation between post-isometric contractions reductions in concentric moment and EMG magnitude

Experimental Hypothesis 3

There will be no stretch-induced reduction in moment and EMG magnitude when stretches are performed after the maximal isometric contractions

Null Hypothesis 3

There will be a stretch-induced reduction in moment and EMG magnitude when stretches are performed after the maximal isometric contractions

4.3. Methods

4.3.1. Participants

Sixteen active participants (8 women and 8 men; age = 20.2 ± 2.6 y, mass = 65.5 ± 10.5 kg, height = 1.7 ± 0.1 m) with no recent history of lower limb injury or illness volunteered for the study after providing written and informed consent. The participants were asked to avoid intense exercise, stretching and stimulant use for 48 hr prior to testing. Ethical approval was granted by the Ethics Committee's of The School of Sport and Education at Brunel University and The School of Health at The University of Northampton and the study was conducted in accordance with the declaration of Helsinki.

4.3.2. Protocol

Equipment, processing, calculations and normalisation for peak concentric and passive ankle moment, ROM, neuromuscular activity (EMG), muscle and tendon length and stiffness were identical to Study 1 (see Chapter 3). The participants were initially familiarised with the testing protocol one week prior to data collection. As the same participants, measures and protocol were employed in each study, control condition data were used from Study 1 to establish reliability of the measures (see Chapter 3). During the experimental sessions, the participants performed a 5-min warm-up on a Monark cycle at 60 revolutions/min with a 1-kg resistance load producing a power output of 60 W. The participants were then seated upright in the chair of an isokinetic dynamometer (Biodex System 3 Pro, IPRS, Suffolk, UK) with knee fully extended (0°) and the ankle placed in neutral position (0°) with the sole of the foot perpendicular to the shank, and the lateral malleolus aligned to the centre of rotation of the dynamometer. The dynamometer footplate initially rotated the participants' ankles to full plantarflexion ($\sim 30^\circ$), and then the participants' ankles were passively rotated to their maximum dorsiflexion range of motion (ROM) at $0.087 \text{ rad}\cdot\text{s}^{-1}$ ($5^\circ\cdot\text{s}^{-1}$). Whilst in this position the participants performed a maximal concentric plantarflexor contraction at an angular velocity of $0.087 \text{ rad}\cdot\text{s}^{-1}$. Subsequently, the participants produced six 8-s ramped maximal voluntary isometric contractions (MVICs) with the ankle in neutral position (0°). The participants then repeated the passive and active trials to determine any effects of isometric contractions. Three 60-s static plantarflexor stretches were then imposed by rotating the ankle to full dorsiflexion ROM, with 60 s of rest included between each stretch. The participants subsequently repeated the passive and active trials at 2 min and 30 min post-stretch to determine the effects of stretch. The order and time of the experimental protocol including the passive and concentric trials and isometric and stretch protocols is shown in Figure 4.3.1.

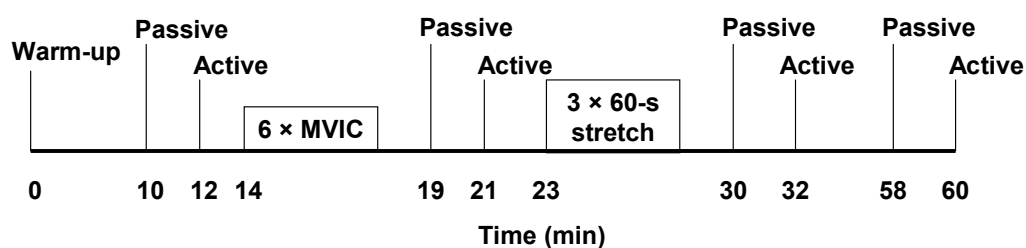

Figure 4.3.1. Timeline of the maximal voluntary isometric contractions (MVICs) and stretch interventions.

4.3.3. Joint Moment during the passive trials

While seated with a hip angle of 55° and their knee extended the participants' ankles were passively rotated through their full ROM at $0.087 \text{ rad}\cdot\text{s}^{-1}$. They were instructed to volitionally terminate the rotation by pressing a hand held release button at the point of discomfort. Passive moment was recorded throughout the trial and then normalised (as a percentage) to the maximum pre-MVIC passive joint moment ($\%M_{\text{pas}}$). To account for inter-individual differences in joint flexibility/ROM, moment data were analysed at 50%, 70% and 90% of maximum pre-MVIC ROM. Full ROM was calculated from the passive joint moment inflection point (see Figure 3.3.2), where a clear change in the slope of the passive moment curve occurred, to the volitional end of the ROM.

4.3.4. Joint Moment during the concentric trials

Whilst seated with an 85° hip angle and the knee extended, the dynamometer rotated the participants' ankles through their ROM at $0.087 \text{ rad}\cdot\text{s}^{-1}$ until reaching the point of discomfort. The participants then maximally contracted the plantarflexors until maximal isometric moment was attained (i.e. there was a visible plateau in the moment trace) before the footplate of the dynamometer was released at $0.087 \text{ rad}\cdot\text{s}^{-1}$. Concentric plantarflexor moment was normalised as a percentage of the maximum plantarflexor moment measured during the maximum voluntary isometric contraction ($\%M_{\text{MVIC}}$). Maximal concentric moment was recorded throughout the full ROM; data were analysed only at 50% (mean angle = $7.7 \pm 3.8^\circ$ plantarflexion), 70% (mean angle = $0.7 \pm 5.3^\circ$ plantarflexion) and 90% (mean angle = $6.2 \pm 6.8^\circ$ dorsiflexion) of the full ROM, calculated between full plantarflexion (0%) and full dorsiflexion (100%), to remove inter-individual variations in flexibility. Analysis was not conducted at joint angles $<50\%$ of ROM as the slow concentric velocity ($5^\circ\cdot\text{s}^{-1}$) resulted in a total contraction period of approximately 12 s and incurred substantial fatigue. During testing, joint moment, joint angle and angular velocity data for both passive and active trials were directed from the dynamometer to a high level transducer (model HLT100C, Biopac, Goleta, CA) before analogue-to-digital conversion at a 2000-Hz sampling rate (model MP150 Data Acquisition, Biopac). The data were then directed to a personal computer running AcqKnowledge software (v3.8.2, Biopac) and filtered with a double pass 6-Hz Butterworth low pass filter.

4.3.5. Isometric intervention

Two minutes after completing the concentric trial, the participants' ankles were passively rotated from full plantarflexion at $0.087 \text{ rad}\cdot\text{s}^{-1}$ until they reached the anatomical position (0°). The participants then produced a ramped maximal isometric plantarflexor contraction with maximal moment reached ~ 3 s after contraction initiation (visible plateau in the active moment curve); the participants then slowly reduced their force to zero (total contraction time ~ 8 s). The ramped contractions allowed tendon deformation to be determined, which then enabled tendon stiffness to be calculated. The participants' ankles were then returned to a plantarflexed

position (25°) and this process was repeated after a 30-s rest with participants completing a total of six contractions during the isometric trial. The participants' ankles were plantarflexed after each contraction to enable motion analysis data recording the movement of a reflective marker placed on the dynamometer footplate to be synchronized with ROM data exported from the dynamometer. During the familiarisation trials, the participants' isometric joint moment data during contraction were observed and trials repeated until the participants could consistently achieve 1) a linear increase in joint moment, 2) a visible plateau (maximal moment; *marker A*) and 3) a linear decrease in moment over an 8 s timeframe (see Figure 4.3.2), to ensure all participants completed a similar amount of isometric work and induced similar strain in the MTC. During testing, joint moment and joint angle data were continuously and synchronously recorded throughout the isometric trial period, as described below. Two minutes after completing the six isometric contractions, the participants repeated the passive and active trials to determine any effects of the isometric contractions.

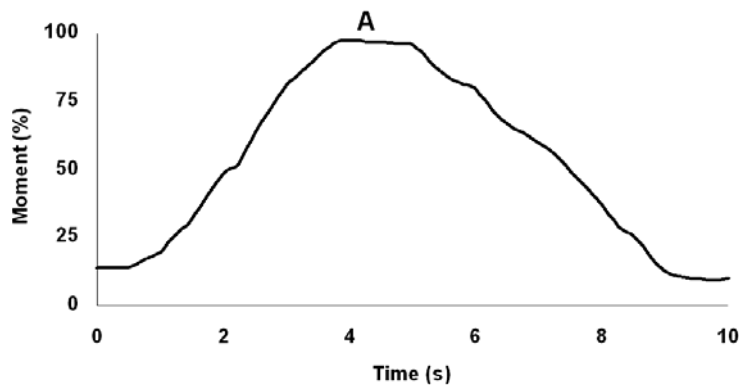

Figure 4.3.2. Active joint moment during a ramped isometric plantarflexion trial measured in the anatomical position (0°).

4.3.6. Stretch protocol

The stretch protocol including duration and intensity was identical to Study 1 (see Chapter 3). Two minutes after completing the second concentric trial, the participants' ankles were passively rotated at $0.087 \text{ rad}\cdot\text{s}^{-1}$ through their full ROM until reaching the point of discomfort. The participants' ankles were held in the stretched position for 60 s and then released at $0.087 \text{ rad}\cdot\text{s}^{-1}$, returning the foot to a fully plantarflexed position. After 60 s of rest, the stretch protocol was repeated (twice), giving a total stretch duration of 180 s.

4.3.7. Electromyographic (EMG) recording

Site preparation, electrode placement, EMG sampling, processing and normalisation methods were identical to Study 1 (Chapter 3). Skin-mounted bi-polar double differentiated active electrodes (model MP-2A, Linton, Norfolk, UK) constantly monitored the EMG activity of the soleus (Sol), gastrocnemius medialis (GM), gastrocnemius lateralis (GL) and tibialis anterior

(TA). EMG signals were amplified (gain = 300, input impedance = 10 G Ω , CMRR = > 100 dB at 65 Hz) and directed to a high level transducer (model HLT100C, Biopac) before analogue-to-digital conversion at a 2000-Hz sampling rate (model MP150 Data Acquisition, Biopac). The signals were then directed to a personal computer running AcqKnowledge software (v3.8.2, Biopac) where they were filtered using a 20- to 500-Hz band-pass filter. A linear fast fourier transformation (FFT) (calculated at 90% of ROM; 1 s window) was performed to determine the mean and median spectral frequency content of the EMG signal. The filtered signal was then converted to root mean squared (RMS) EMG with a 250-ms sample window, and normalised as a percentage of the peak amplitude recorded during a maximal voluntary isometric contraction. The normalised EMG amplitude (%_{MVIC}) was used as a measure of neuromuscular activity; the normalised EMG signals for GM, GL and Sol were then averaged to reflect the representative activity of the triceps surae (TS) muscle group. In addition, the EMG:moment ratios were calculated at 50%, 70% and 90% of ROM. The antagonist tibialis anterior (TA) EMG data were processed and normalised using the same method.

4.3.8. Gastrocnemius medialis (GM) muscle length and Achilles tendon length and stiffness

The methods for measuring GM muscle length and Achilles tendon length and stiffness were identical to Study 1 (Chapter 3). Movement of the ankle in the dynamometer footplate was recorded using a real-time motion analysis system with three infrared digital cameras (ProReflex, Qualisys, Gothenburg, Sweden) operating Track Manager 3D (v.1. 8.226, Qualisys) software. Infrared reflective markers were placed over the insertion of the Achilles at the calcaneus, the origin of the medial head of the gastrocnemius at the medial femoral epicondyle, and over the GM-Achilles MTJ, with adhesive zinc-oxide hypoechoic tape placed on the skin aligned with this marker. Raw coordinate data were sampled at 100-Hz and smoothed using a 100-ms averaging window prior to the calculation of Achilles tendon and GM muscle lengths.

The GM-Achilles MTJ was identified using real-time ultrasound video imaging (LOGIQ Book XP, General Electric, Bedford, UK) using a wide-band linear probe (8L-RS, General Electric) with a 39 mm wide field of view and coupling gel (Ultrasound gel, Dahlhausen, Cologne, Germany) between the probe and skin. The probe was then affixed perpendicular to the skin to maintain a constant position with zinc-oxide adhesive tape, which ensured consistent imaging of the MTJ and the hypoechoic tape throughout the trial. Ultrasound images were sampled at 28 Hz and the position of the MTJ was manually digitised at 4.67Hz (Peak Motus, Englewood, CO). Motion analysis, ultrasound and dynamometer data were synchronised using a 5-V ascending transistor-transistor linear (TTL) pulse. GM muscle length was calculated as the distance between reflective *markers B* and *C* (see Figure 3.3.8), plus the distance from actual MTJ position (determined with ultrasound; see Figure 3.3.12). Tendon length was calculated as the distance between reflective *markers A* and *C*, minus the distance from actual MTJ position. Tendon stiffness was calculated by dividing tendon length change by the change in ankle moment at 90% of ROM (mean = 6.2 \pm 6.8° dorsi flexion).

4.3.9. Data Analysis

All data were analysed using SPSS statistical software (v.11.5; LEAD Technologies, Chicago, IL); group data reported are means \pm standard error (SE), change data reported are means \pm standard deviation (SD). The study protocol included two interventions, isometric contractions (MVICs) and static stretches. Paired t-tests were used to test for differences in 1) peak isometric moment and EMG, and 2) muscle and tendon length and stiffness between the first and sixth isometric contraction (MVIC). All data were initially screened to test for assumptions of normal distribution using Kolmogorov-Smirnov and Shapiro-Wilks, which revealed no significant effect ($P > 0.05$) indicating the data were normally distributed. As repeated measures experimental designs were employed, the further assumption of sphericity needed to be determined. Where Mauchly's test of sphericity revealed no significant effect ($P > 0.05$), the sphericity assumed F ratio was used to determine significant differences between groups. Where sphericity was violated ($P < 0.05$), the Greenhouse-Geisser adjustment was implemented to determine significance. Multiple analyses of variance (MANOVA) with repeated measures were used to test for differences in EMG mean and median frequencies. Separate analyses of variance (ANOVA) with repeated measures were used to test for differences in 1) concentric and passive plantarflexor moment, 2) EMG amplitude and EMG:moment ratio, and 3) GM muscle and Achilles tendon lengths and tendon stiffness. Pearson's product moment correlation was used to determine the relationship between post-MVCCs reductions in moment and changes in EMG amplitude. Consistent with statistical procedures (Field, 2005), Bonferroni correction was applied during the post hoc analysis, where this proved too conservative (masked the location of the difference), Tukey's LSD was applied (specific correction used is reported with each data set). Statistical significance for all tests was accepted at $P < 0.05$.

4.3.10. Reliability

Test-retest reliability for the methods and measures were calculated in pilot testing and during the control condition in Study 1 (see Chapter 3).

4.4. Results

The same participants, measures and testing protocol (with the exception of different interventions) were employed in each study within the thesis, therefore control condition data were used from the first study to establish reliability of the measures. As reported in Chapter 3, during the no-stretch condition (control condition), no significant difference in any measure at any joint ROM was detected following 5 min of complete rest ($P > 0.05$).

The current study protocol included two interventions: a) 6 ramped maximal voluntary isometric contractions (MVICs) followed by b) 3 min of passive static stretching; and examined the impact of these interventions on several measures. For clarity, the results have been separated into sections devoted to each measure.

4.4.1 Isometric joint moment and EMG amplitude during the 1st and 6th contraction within the isometric intervention

There was no significant difference in peak isometric joint moment between the first and sixth isometric contractions ($P > 0.05$) indicating that fatigue was not induced (see Figure 4.4.1). A significant increase in Sol EMG amplitude was detected (15.5%; $P < 0.05$), however no change in EMG was detected in the other triceps surae muscles (GL, GM) or when EMG was averaged (TS) across the muscles (3.5%; $P > 0.05$). No change in TA EMG was observed, indicating that co-activity of the antagonist muscle was unchanged.

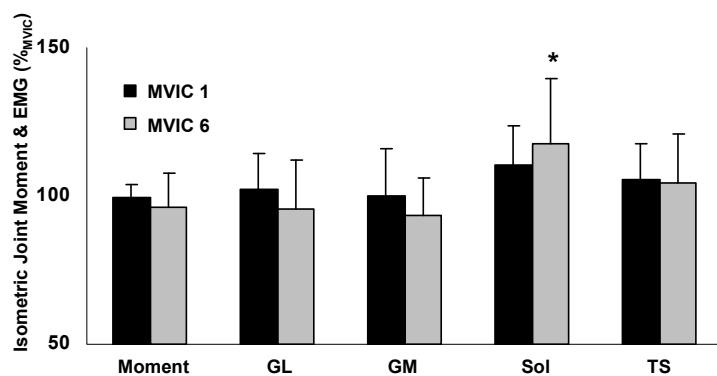

Figure 4.4.1. Normalised isometric joint moment and electromyographic (EMG) amplitude during the 1st and 6th maximal voluntary isometric contraction (MVIC). *Significant to $P < 0.05$ compared to MVIC₁ group.

4.4.2. Changes in concentric joint moment after isometric contractions (hypothesis 1) and 3-min of passive stretch (hypothesis 3)

There was a significant reduction in concentric joint moment detected at 50% ($F = 9.94$; $P < 0.001$), 70% ($F = 12.53$; $P < 0.001$) and 90% ($F = 11.62$; $P < 0.001$) of ROM (see Appendix 3; Table 4.4.1). Post hoc t-test analyses with Bonferroni correction revealed significant reductions (mean = $11.5 \pm 1.3\%$; $P < 0.01$) immediately post-MVIC at all joint angles (see Figure 4.4.2). There was no change ($P > 0.05$) in concentric joint moment at any ROM from pre- to post-stretch, indicating that the stretch protocol did not impact upon force production. However, plantarflexor moment increased significantly 30 min later at 70% and 90% of ROM when compared to immediately post-stretch data (see Figure 4.4.2), and recovered sufficiently so that it was no longer significantly depressed relative to pre-MVIC baseline levels ($4.7 \pm 2.4\%$).

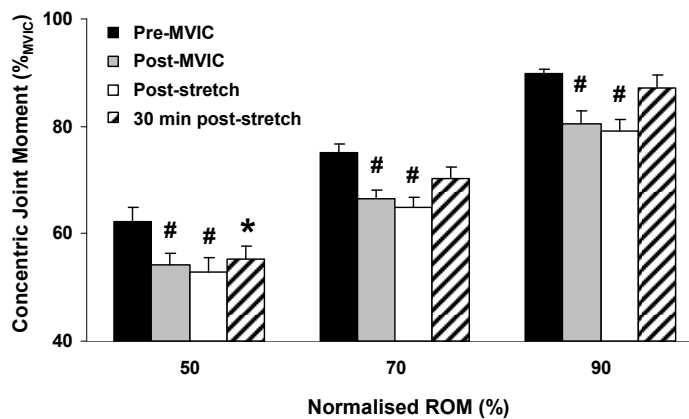

Figure 4.4.2. Normalised moment during maximal concentric plantarflexion trials measured at 50%, 70% and 90% of ROM. *Significant to $P < 0.05$, [#]significant to $P < 0.01$ compared to pre-MVIC group.

4.4.3. Changes in EMG after isometric contractions (hypothesis 1) and 3-min of passive stretch (hypothesis 3)

There was a significant reduction in peak TS EMG amplitude detected at 50% ($F = 3.88$; $P < 0.01$), 70% ($F = 4.85$; $P < 0.01$) and 90% ($F = 5.23$; $P < 0.01$) of ROM during the concentric contractions (see Appendix 3; Table 4.4.2), with similar reductions ($P < 0.05$) in all EMG amplitudes (GL, GM & Sol) also found. A significant reduction was also detected in TS EMG:moment ratio at 50% ($F = 4.29$; $P < 0.01$), 70% ($F = 7.57$; $P < 0.01$) and 90% ($F = 6.99$; $P < 0.01$) of ROM. No change was detected in the mean (pre-MVIC = 214.8 ± 5.4 Hz, post-MVIC = 225.6 ± 5.6 Hz; $P > 0.05$, TS EMG) or the median (pre-MVIC = 117.6 ± 4.8 Hz, post-MVIC = 126.7 ± 5.0 Hz; $P > 0.05$, TS EMG) frequency of any EMG signal. Consistent with the changes in concentric plantarflexor moment, post hoc t-test analyses with Bonferroni correction revealed significant reductions ($P < 0.01$) in peak TS EMG amplitude ($21.0 \pm 0.3\%$) immediately post-MVIC at all joint angles (see Figure 4.4.3). Similar reductions were detected in all EMG amplitudes (GL mean = $23.5 \pm 2.5\%$; GM mean $22.6 \pm 3.0\%$; Sol mean = $16.3 \pm 1.8\%$; $P < 0.05$). A significant reduction in TA EMG amplitude ($13.7 \pm 1.8\%$; $P < 0.05$) was also detected at 90% of ROM, suggesting that the MVICs intervention also decreased muscular co-activity at

this joint angle. There was no change ($P > 0.05$) in any EMG amplitude at any ROM from pre- to post-stretch, indicating that the stretch protocol did not impact upon neuromuscular activity. However, consistent with the changes in concentric plantarflexor moment, EMG amplitude increased significantly after 30 min at 70% and 90% of ROM when compared to immediately post-stretch data (see Figure 4.4.3), and recovered sufficiently so that it was no longer significantly depressed relative to pre-MVIC baseline (GL = $4.8 \pm 4.4\%$; GM = $7.3 \pm 3.0\%$; Sol = 2.3 ± 4.8 ; TS = $3.2 \pm 1.1\%$).

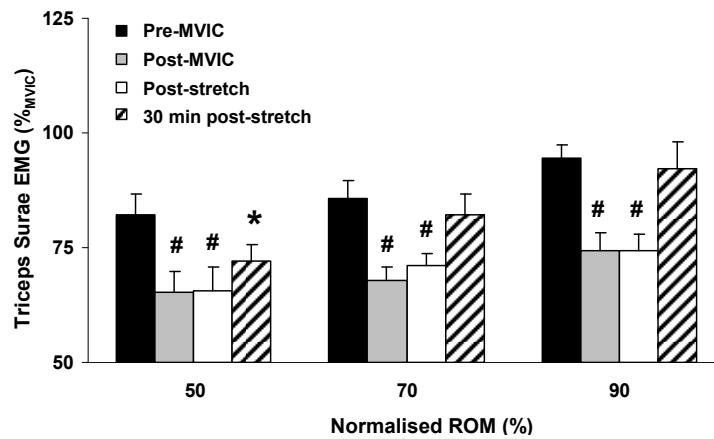

Figure 4.4.3. Normalised triceps surae (TS) electromyographic (EMG) amplitude during maximal concentric plantarflexion trials measured at 50%, 70% and 90% of ROM. *Significant to $P < 0.05$, #significant to $P < 0.01$ compared to pre-MVIC group.

Similarly, post hoc t-test analysis with Tukey's LSD correction revealed a significant reduction in EMG:moment ratio at all joint angles (see Figure 4.4.4) immediately post-MVIC compared to the pre-MVIC group ($P < 0.01$) as the average reduction in EMG (21%) was greater than the average deficit in joint moment (11.5%). Consistent with the changes in joint moment and EMG, no further significant change was detected immediately post-stretch but the ratio recovered so that it was no longer significantly depressed relative to the pre-MVIC group 30 min later ($1.5 \pm 1.8\%$; $P > 0.05$).

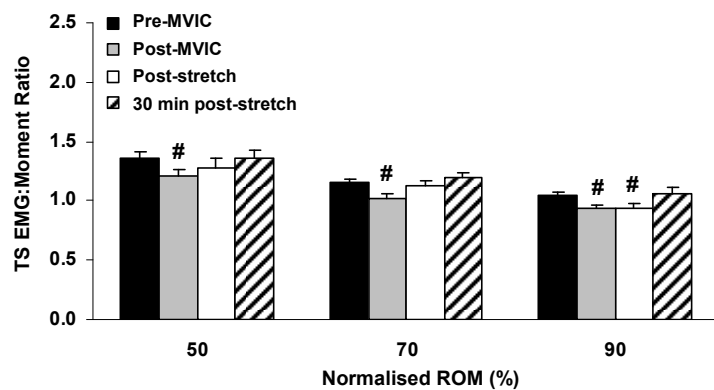

Figure 4.4.4. Triceps surae (TS) electromyographic (EMG):moment ratio during maximal concentric plantarflexion trials measured at 50%, 70% and 90% of ROM. #Significant to $P < 0.01$ compared to pre-MVIC group.

4.4.4. EMG: Moment correlation (hypothesis 2)

Pearson's product moment correlations computed between post-MVIC reductions in triceps surae EMG and decreases in joint moment were significant at 50% ($r = 0.90$; $P < 0.01$), 70% ($r = 0.73$; $P < 0.01$) and 90% ($r = 0.74$; $P < 0.01$) of ROM (see Figure 4.4.5), indicating that the participants who had the greater reductions in EMG amplitude tended also to exhibit a greater loss of active joint moment.

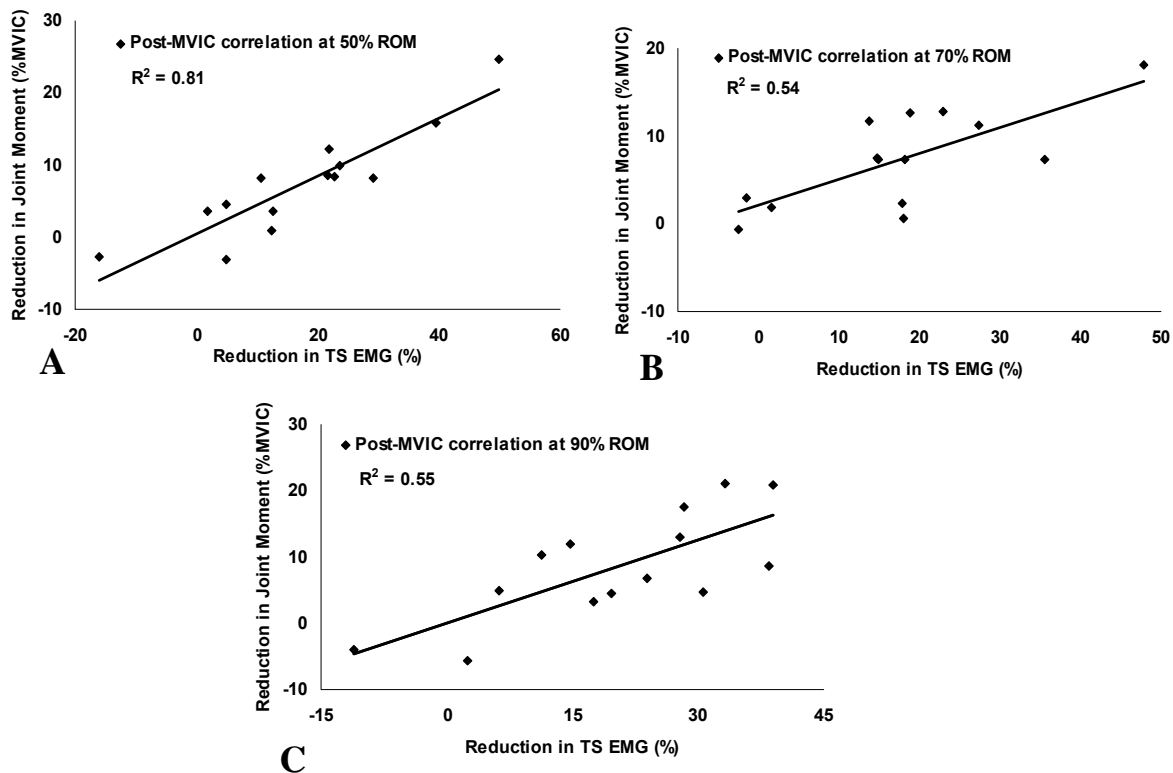

Figure 4.4.5. Correlations between post-maximal isometric contractions (MVICs) reductions in concentric joint moment and triceps surae (TS) electromyographic (EMG) amplitude (A = 50%; B = 70%; C = 90% of ROM).

Significant correlations were also found between the reductions in concentric moment and the reductions in GL EMG at 50% ($r = 0.68$; $P < 0.01$), 70% ($r = 0.55$; $P < 0.05$) and 90% ($r = 0.56$; $P < 0.05$) of ROM; with GM EMG at 50% ($r = 0.56$; $P < 0.05$) and 70% ($r = 0.63$; $P < 0.05$) of ROM; with Sol EMG at 50% ($r = 0.85$; $P < 0.01$) ROM, 70% ($r = 0.64$; $P < 0.05$) and 90% ($r = 0.67$; $P < 0.05$) of ROM (data not shown). However, the averaging of individual muscle EMG amplitudes to create a single EMG amplitude representative of the triceps surae muscle group (TS EMG) generated the strongest EMG correlations with reductions in moment at all joint angles.

Correlations computed between the recovery in triceps surae EMG and the recovery in concentric joint moment 30 min later were also significant at 70% ($r = 0.63$; $P < 0.05$) and 90% ($r = 0.73$; $P < 0.01$) of ROM (see Figure 4.4.6), with the participants who achieved greater recovery in EMG tending also to exhibit a greater recovery of active joint moment. Significant

correlations were also detected between the recovery in concentric moment with the recovery in GL EMG ($r = 0.57$; $P < 0.05$) at 70% of ROM and with GM EMG ($r = 0.63$; $P < 0.05$) and with Sol EMG ($r = 0.57$; $P < 0.05$) at 90% of ROM (data not shown). Consistent with the correlations reported earlier between reductions in joint moment and EMG amplitude, the averaging of individual muscle EMG amplitudes to create a single EMG amplitude representative of the triceps surae muscle group (TS EMG) generated the strongest correlations with recovery in moment.

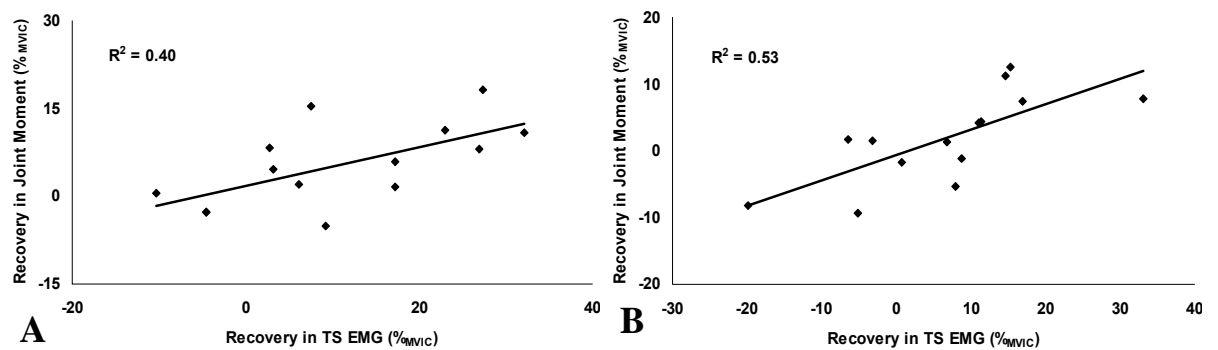

Figure 4.4.6. Correlations between 30 min post-stretch recovery in concentric joint moment and triceps surae (TS) electromyographic (EMG) amplitude (A = 70%; B = 90% of ROM).

4.4.5. Changes in passive joint moment after isometric contractions (hypothesis 1) and 3-min of passive stretch (hypothesis 3)

There was a significant difference in passive joint moment detected at 50% ($F = 5.43$; $P < 0.01$), 70% ($F = 6.52$; $P < 0.01$) and 90% ($F = 4.84$; $P < 0.01$) of ROM (see Appendix 3; Table 4.4.3). Post hoc t-test analyses with Bonferroni correction revealed a significant reduction (mean = $4.9 \pm 0.7\%$; $P < 0.01$) immediately post-MVIC at 50%, 70% and 90% of ROM (see Figure 4.4.7). There was no change ($P > 0.05$) in passive joint moment at any ROM immediately or 30 min after stretch, indicating that stretch had no significant impact on passive moment. Passive joint moment also remained significantly depressed 30 min later compared to the pre-MVIC group.

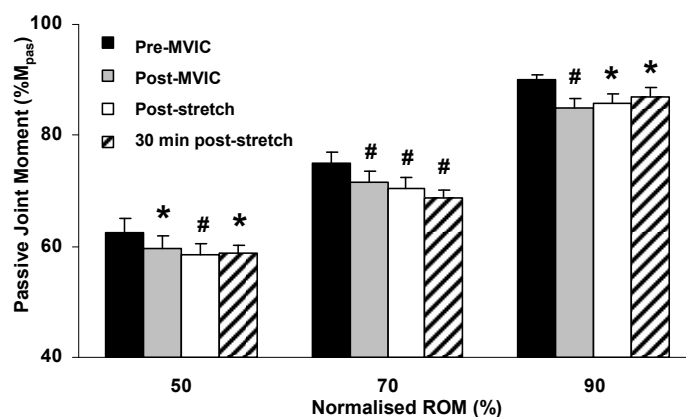

Figure 4.4.7. Joint moment during passive trials measured at 50%, 70% and 90% of ROM. *Significant to $P < 0.05$, #significant to $P < 0.01$ compared to pre-MVIC group.

4.4.6. Achilles tendon length and stiffness and GM muscle length during the isometric intervention

Achilles tendon length and stiffness, and GM muscle length were calculated during the first and sixth contractions at 30%, 50%, 70% and 90% of MVIC (determined in the first contraction). Mean data revealed a trend towards a longer tendon ($MVIC_1 = 187 \pm 7$ mm, $MVIC_6 = 190 \pm 7$ mm; data taken from 90% of MVIC) and shorter GM muscle length ($MVIC_1 = 243 \pm 5$ mm, $MVIC_6 = 241 \pm 5$ mm) at all MVIC percentages, which became significant (1.2%; $P < 0.01$) at 90%_{MVIC} (see Figure 4.4.8). Achilles tendon stiffness was also significantly reduced (8.3 ± 2.7%; $P < 0.05$) from 9.2 ± 0.9 Nm/mm ($MVIC_1$) to 8.3 ± 0.7 Nm/mm ($MVIC_6$).

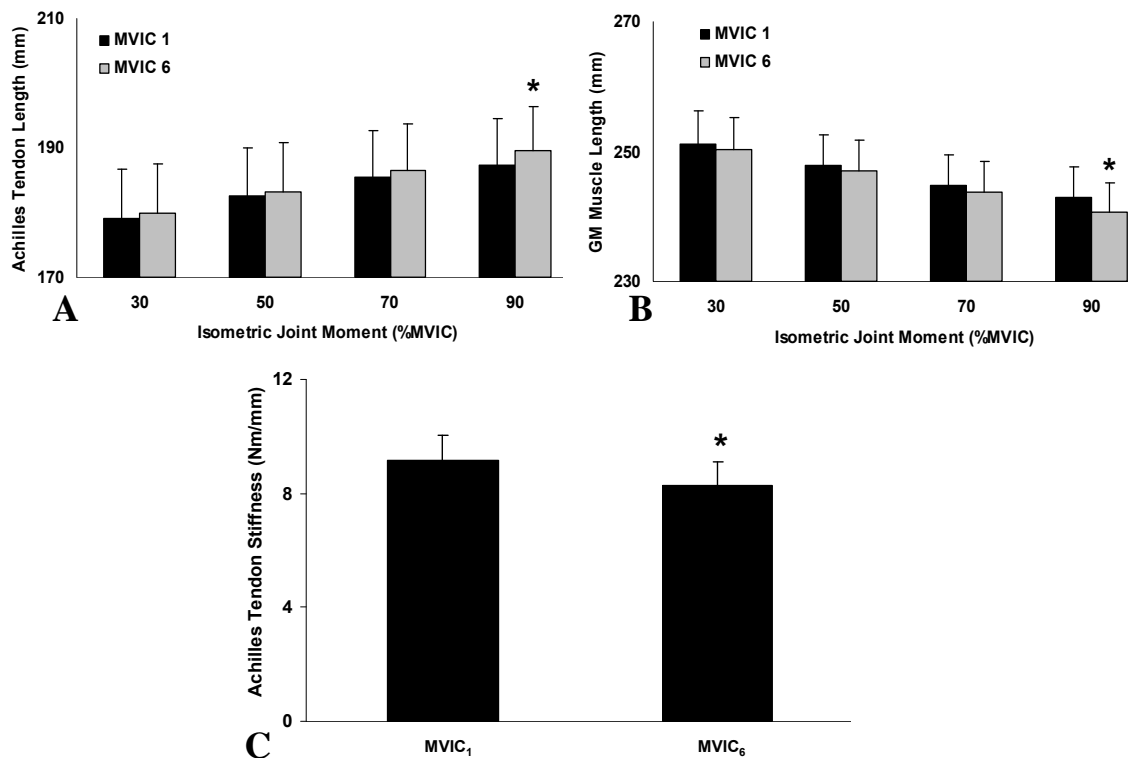

Figure 4.4.8. Achilles tendon length (A), gastrocnemius medialis (GM) muscle length (B) and Achilles tendon stiffness (C) during the 1st and 6th maximal voluntary isometric contraction (MVIC). *Significant to $P < 0.05$ compared to $MVIC_1$.

4.4.7. Achilles tendon length and stiffness and GM muscle length during the concentric trials (hypotheses 1 and 3)

No significant change in muscle or tendon length was detected at any ROM during the concentric trial ($P > 0.05$), indicating that the muscle operating length had not changed during this contraction mode (see Appendix 3; Table 4.4.4). However, a significant reduction in tendon stiffness ($F = 8.21$; $P < 0.01$) was revealed (see Appendix 3; Table 4.4.4). Consistent with the reductions in concentric moment and EMG, post hoc t-test analyses with Bonferroni correction revealed a significant reduction ($P < 0.01$) in Achilles tendon stiffness immediately post-MVIC ($10.9 \pm 1.0\%$; $P < 0.01$) from 9.1 ± 1.0 Nm/mm pre-MVIC to 8.2 ± 0.9 Nm/mm post-MVIC

(calculated at 90% of ROM; see Figure 4.4.9) during the concentric contraction, as the magnitude of length change of the tendon (pre-MVIC = 12.7 ± 3.3 mm; post-MVIC = 12.9 ± 4.1 mm) was similar despite the lower muscle force ($11.5 \pm 1.3\%$). No significant change was detected immediately or 30 min after stretch, indicating that stretch had no further impact on tendon stiffness. Tendon stiffness also remained lower 30 min later.

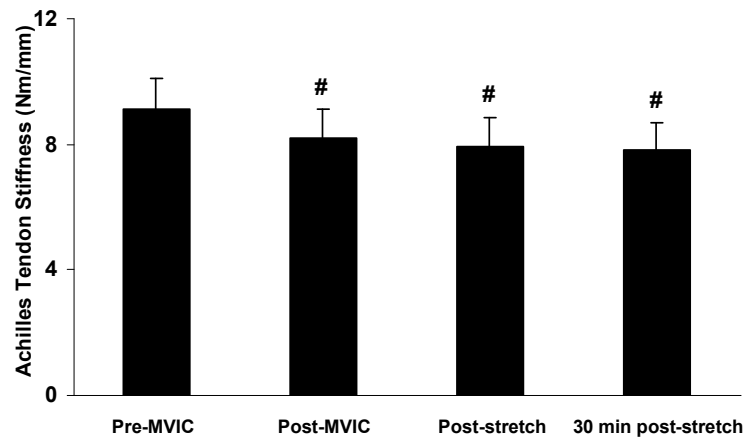

Figure 4.4.9. Achilles tendon stiffness calculated during the concentric trials measured at 90% of ROM. #Significant to $P < 0.01$ compared to pre-MVIC group.

4.4.8. Achilles tendon length and stiffness and GM muscle length during the passive trials (hypotheses 1 and 3)

No significant change was found in Achilles tendon or GM muscle lengths ($P > 0.05$) (see Appendix 3; Table 4.4.5); however there was a trend towards increased Achilles tendon length (under significantly less force) and decreased GM muscle length at all ROMs post-MVIC (see Figure 4.4.10). These results are indicative of the decreased tendon stiffness.

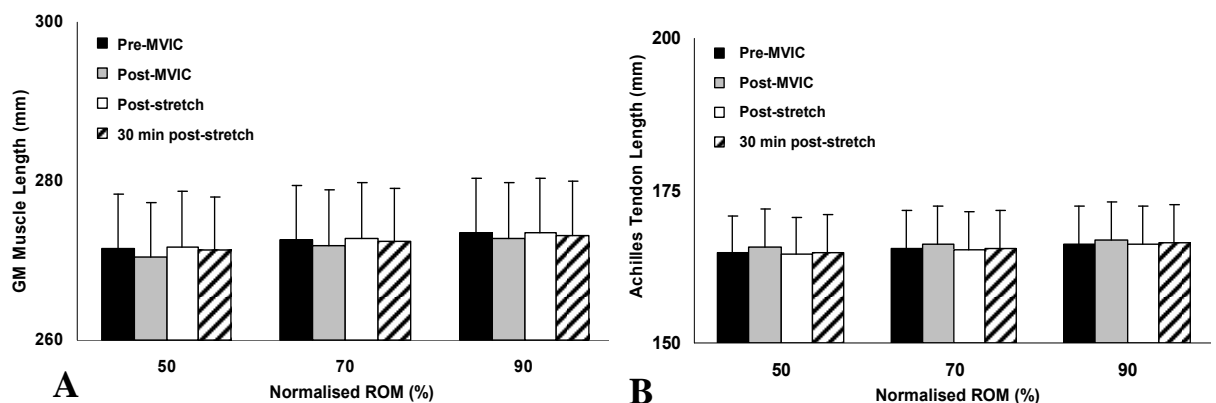

Figure 4.4.10. Gastrocnemius medialis (GM) muscle (A) and Achilles tendon (B) length calculated during the passive trials measured at 50%, 70% and 90% of ROM.

4.5. Discussion

The aims of the present study were twofold; first to determine the effects of six maximal voluntary isometric contractions (MVICs) on Achilles tendon stiffness, passive and concentric force production and neuromuscular activity (EMG), and second, to determine whether there were any additional changes in these measures following 3 min of static stretch. Following the MVIC intervention active (concentric) joint moment was significantly lower at all joint angles (mean = $11.5 \pm 1.3\%$; $P < 0.01$) and this was accompanied by, and correlated with ($r = 0.90$; $P < 0.01$), reduced triceps surae EMG amplitude (mean = $21.0 \pm 0.3\%$; $P < 0.01$). These changes could not be attributed to the initial concentric contraction as no change in any measure ($P > 0.05$) was detected in the control condition where the concentric protocol was employed followed by 5 min of rest before repeating the concentric trial. Also, metabolic muscle fatigue could not account for the force depression as there was no change in isometric joint moment between the first and sixth (last) isometric contractions or in the mean or median EMG frequency during concentric contractions. The MVIC intervention also resulted in a significant decrease in passive joint moment (mean = $4.9 \pm 0.7\%$; $P < 0.01$), indicating a decreased stiffness of the muscle-tendon complex (MTC) or joint capsule. The findings of a trend towards a longer tendon length during the passive joint rotation and a significantly reduced tendon stiffness measured during the maximal concentric contraction (mean = $10.7 \pm 1.3\%$; $P < 0.01$) is suggestive that the reduced passive joint moment was attributable to a reduction in tendon stiffness. Importantly, the stretch intervention imposed after the MVIC intervention did not cause any further change in muscle-tendon properties, neuromuscular activity or force generating capacity of the triceps surae muscles. Finally, significant increases were detected in active joint moment and EMG amplitude in the most dorsiflexed positions after 30 min of passive recovery allowed after the stretch intervention, but passive moment and Achilles tendon stiffness remained depressed. Given these findings the first hypothesis that there would be a significant reduction in Achilles tendon stiffness, active and passive plantarflexor moment and EMG post-MVICs can be accepted. The second hypothesis that there would be a significant correlation between post-MVICs reductions in concentric moment and EMG can be accepted. Finally, the third hypothesis that the stretch-mediated reductions in moment and EMG would be removed following MVICs can be accepted.

The present data indicate that active concentric plantarflexor moment is negatively affected by the performance of maximal isometric contractions (MVICs). These reductions in moment are accompanied by, and highly correlated with, decreases in EMG amplitude. Furthermore, the reductions in concentric plantarflexor joint moment (mean = $11.5 \pm 1.3\%$) and EMG (mean = $21.0 \pm 0.3\%$) were consistent across several joint angles (50%, 70% & 90% of ROM), which indicates that the effect was not joint-angle (muscle length) specific. This finding is in agreement with Study 1 of this thesis. In the present study, a linear relationship was revealed between the decreases in force and EMG amplitude such that over 81% of the variability in moment changes was explained by the changes in EMG amplitude. Although the strongest correlation was found when the EMG amplitude of the three triceps surae muscles were averaged ($r = 0.90$; $P < 0.01$), significant correlations were also found for GM ($r = 0.63$; $P <$

0.05), GL ($r = 0.68$; $P < 0.01$) and Sol ($r = 0.85$; $P < 0.01$) muscles individually. Despite the strong relationship, the reduced active joint moment could not be completely explained by the decrease in EMG ($r = 0.90$; $P < 0.01$; 81% explained variance). Initial pilot testing revealed very high correlations in all three triceps surae muscles' EMG ($r = 0.99$) with joint moment during a ramped isometric plantarflexion (between 70 – 100% MVIC). However, when a maximal contraction is held for a prolonged period (> 5 s), the cyclic turnover of motor units may increase the variability of the EMG signal recorded (Taylor et al., 2000b). This variability may reduce the strength of the correlation computed between EMG losses and reductions in joint moment and, therefore reduce the perceived importance of neural activity as a mechanism underpinning these losses. However, this contention remains speculative and further research is required to determine the variability of the EMG signal at MVC and any subsequent impact to determining the strength of any correlation.

The reduction in EMG measured in the concentric contractions is intriguing because no decrease in force or EMG amplitude was seen during the isometric contractions. Typically reductions in EMG amplitude result from decreased central neural drive (Cramer et al., 2004, 2005; Gandevia, 1992) or peripheral inhibition or disfacilitation of the α -motoneurone pool by associated muscle afferents (Avela et al., 1999). Cramer et al. (2004, 2005) reported significant reductions in moment and EMG in both the control (no stretch) and experimental (stretch) limbs following 2 min of passive stretch, which led the authors to conclude that central mechanisms inhibiting descending neural drive were responsible for these reductions. Alternatively, Avela et al. (1999) reported post-stretch reductions in maximal triceps surae moment, EMG, and Hoffmann (H)-reflexes in conjunction with increased MTC compliance (30 min stretch-duration). The authors suggested that increased muscle compliance may have reduced resting neural discharge of the muscle spindles (group Ia and II afferents). This contention was supported by the observed reduction in H-reflexes, thus lowering overall excitatory input to the α -motoneurone pool resulting in reduced EMG amplitude and joint moment. However, the authors did not conduct sonographic imaging of the MTC and were, therefore, speculating as to which tissues were responsible for the reduced stiffness. Kubo et al. (2001a) revealed that 10 min of stretch (less than the 30 min used by Avela et al.) can reduce tendon stiffness, and also reported a similar finding following isometric contractions (Kubo et al., 2001b; present study data). The reduction in tendon stiffness could increase the activity from the inhibitory golgi tendon organs (GTO; group Ib afferents) and hyperpolarise the α -motoneurone pool. This would reduce the ability of the excitatory descending neural drive to depolarise and activate the α -motoneurone pool and would reduce EMG activity in the triceps surae and joint moment accordingly. However, the present data are suggestive of central rather than peripheral mechanisms influencing EMG amplitude since peripheral alterations would be expected to influence EMG during both the isometric and concentric contractions. Furthermore, peripheral inhibition of the α -motoneurone pool from increased GTO activity should increase co-activity of the TA muscle. However, a significant reduction was detected in TA EMG (mean = $13.7 \pm 1.8\%$; $P < 0.05$), lending further support to central rather than peripheral mechanisms being responsible for the reductions in neuromuscular activity. To the author's knowledge, no other

studies have reported contraction mode-dependent changes in muscle force and EMG, therefore further research is required as these results may have practical implications for muscle performances that rely on concentric force production.

Despite the strong relationship, the reduced active joint moment could not be completely explained by the decrease in EMG. Another possible mechanism of force reduction is a change in tendon stiffness, as this could result in a change in muscle operating length (Kubo et al., 2001b); the leftward shift in its force-length curve would cause the plantarflexors to operate further down their ascending limb (Maganaris, 2001, 2003). This hypothesis appears to be supported by the significant reduction in tendon stiffness detected during the concentric trial post-MVICs in the present study (10.9%). However, ultrasound imaging of the MTJ revealed no change in tendon length (< 0.1 mm) or muscle operating length after the maximal isometric contractions during the concentric trials, despite an 11.5% reduction in concentric moment. Thus, the decrease in force production, combined with reduced tendon stiffness, allowed the muscle to work at the same length at a given joint angle. Thus, a leftward shift in the force-length curve was not present, and cannot explain the reduced muscle force. To ensure the present methods could detect a change in tendon length, a linear regression was employed to model tendon deformation during a ramped MVIC. This model calculated a projected 2 mm reduction in tendon deformation from the 11.5% reduction in joint moment seen in the present data; therefore the present methods should be able to detect this small, but significant change.

One of the present study's foci was to determine the effects of MVICs on tendon stiffness; this was in response to the results reported in the previous study (Chapter 3), where a change in tendon stiffness was not shown following 3 min of passive stretch. Altered mechanical properties, possibly resulting from changes in tendon stiffness, have commonly been hypothesised within the literature to explain the post-stretch force deficit phenomenon (Cramer et al., 2004, 2007; Fowles et al., 2000; Kay & Blazevich, 2008; Nelson et al., 2001a, 2001b, Weir et al., 2005). Significant reductions in tendon stiffness have been reported following stretch (> 10 min; Kubo et al., 2001b) and following isometric contractions (Kubo et al., 2001b; present study). Shorter duration stretch (< 5 min; Morse et al., 2008; Chapter 3), however, does not affect Achilles tendon stiffness. Collectively, these studies suggest that the duration and intensity of tissue strain imposed by either stretching or strong muscular contractions may influence the changes in tendon stiffness. The data from these studies do not support a reduction in the force-length (F-L) characteristics as a mechanism implicated with reduced joint moment, regardless of the intervention employed (stretch or MVICs). Therefore, given that data from these studies revealed a significant (present study) or non significant (Study 1, Chapter 3) reduction in tendon stiffness, but no change in muscle operating length, changes to F-L properties were not a mechanism associated with the reductions seen in joint moment post-intervention. The removal of a commonly hypothesised mechanism is an important step in our understanding of the mechanisms underpinning the reductions implicated with these commonly reported force losses.

Although altered force-length characteristics were clearly not a mechanism for the force depression, the decreased tendon stiffness as a result of the isometric contractions might have functional consequences. Tendon structures account for 42.5 – 60% of total work done during the concentric phase (Belli & Bosco, 1992; Bobbert et al., 1986; Voigt et al., 1995) of stretch-shortening cycle (SSC) exercise, where the concentric action of the MTC is preceded by eccentric loading. During locomotion, the stretch-shortening cycle (SSC) occurs during the eccentric loading and concentric unloading of the MTC. During the eccentric loading phase, the forces accepted by the MTC result in the tendon accepting or absorbing energy imparted from contact with the ground. This results in the tendon deforming to accept and store this force (energy), which then unloads this energy during the concentric propulsive phase, thus contributing to the overall joint moment. Interestingly, the stiffness of tendinous structures has also been significantly correlated with rate of force development, maximal isometric force and vertical jump height (Bojsen-Møller et al., 2005; Edman & Josephson, 2007; Kubo et al., 2001b; Wilson et al., 1994) and inversely correlated with neuromechanical delay (Cresswell et al., 1995; Grosset et al., 2009; Kubo et al., 2000). Therefore, a reduction in the stiffness of the tendon may impede fast force transmission through the tendon onto the bone, thus attenuating joint moment. However, a more compliant tendon would store more energy and transfer less force to the musculature during eccentric loading of the MTC, cited as a factor related to injury (Hess, 1989). Therefore, the decrease in tendon stiffness may provide a prophylactic effect and reduce the risk of muscle strain injury. It should also be stated that if a decrease in stiffness is reflective of a decreased tensile strength of the tissue, then there might be an increase in the risk of tendon strain injury. However, strong muscular contractions are commonly performed in athletic populations and with a paucity of tendon rupture reported in the literature (in the healthy tendon), it is unlikely that this is the case. Nonetheless, the reduced maximal joint moment associated with this intervention may increase the injury risk, as strength has also been cited within the aetiology of muscle strain injury (Orchard et al., 1997). Thus, the impact of these contractions on MTC injury risk is worthy of further study.

The examination of the effects of stretch after the performance of a series of intense muscle contractions is important given that many individuals perform a progressively intense warm-up in addition to stretching prior to maximal exercise bouts. Data from the present study clearly indicate that the performance of prior maximal contractions not only has important methodological implications for the experimental design of stretch-based studies but may also have significant practical implications for athletes where maximal concentric contractions are essential to performance. The isometric contraction protocol was chosen to ensure a consistent amount of work was completed between participants and similar strain was applied to the tendinous tissues to enable valid post-intervention statistical analyses. However, a range of maximal contraction modes are commonly performed during athletic pre-performance routines, and rapid eccentric or concentric loading of the MTC may induce different effects to the ones observed following the maximal isometric contractions performed in the present study. Therefore, these data cannot be generalised to athletic populations where different pre-performance regimes may be used and further research is required to determine whether similar

reductions are realised when other contraction modes are used and whether they also mitigate the subsequent effects of stretch.

Notwithstanding the possible differences in the modality of the pre-performance contractions employed in the present study, the examination of the effects of stretch after the performance of a series of intense muscle contractions is important given that many individuals perform a progressively intense warm-up in addition to stretching prior to maximal exercise bouts. Some research studies (Behm et al., 2001; Cornwell et al., 2002; Cramer et al., 2004, 2005; Maisetti et al., 2007; Ryan et al., 2008) but not others (Magnusson et al., 1996c, 1998; Morse et al., 2008) have included maximal contractions in the warm-up or as part of the experimental model prior to testing the effects of static stretch on joint moment. Interestingly, the percentage of studies reviewed in the present thesis (see Chapter 3; Tables 2.7.1 & 2.7.2) reporting significant reductions in joint moment when a warm-up was conducted fell to 57% compared to 92% when no warm-up was performed. However, to our knowledge no studies have specifically examined whether the inclusion of these contractions might mitigate or compound the effects of subsequent stretching. Clearly the MVIC intervention resulted in significant decreases in active (concentric) and passive joint moment. A novel finding of the present study was that no further reductions in concentric joint moment, EMG, passive moment or MTC stiffness were subsequently found post-stretch. This is despite using a stretch protocol that has previously resulted in substantial changes in these variables (see Chapter 4). Thus, the negative effects of stretch appear to be dependent on whether MVICs are performed before them. The impact of prior maximal isometric contractions not only has important methodological implications for stretch-based studies but also has significant practical implications for athletes where maximal concentric contractions are essential to performance. Again, further research is required to determine whether similar reductions are realised when other contraction modes (e.g. concentric) are used prior to stretch and whether they also mitigate the subsequent effects of stretch.

Although the immediate effects of these interventions are important, whether these effects remain apparent for a prolonged period of time (~ 30 min) is possibly more important to activities requiring high levels of force production within the plantarflexors. Interestingly, after 30 min of rest there was a significant recovery of concentric joint moment (64% recovery of the deficit) in the most dorsiflexed positions. This was accompanied by, and correlated with ($r = 0.73$; $P < 0.01$) significant recovery in EMG amplitude (82%), such that force and EMG were no longer significantly reduced compared to baseline levels. However joint moment and EMG did not significantly recover in the most plantarflexed position. Therefore, both the reduction and recovery of joint moment appears to be strongly correlated with neuromuscular activity, which clearly identifies neuromuscular activity as one of the most important mechanisms underpinning these losses. The ability of the CNS to fully activate the triceps surae has been shown to be joint-angle or muscle-length specific (Cresswell et al., 1995; Kawakami et al., 1998), with reduced muscle length or the joint placed in a plantarflexed position limiting neural activity. The current data clearly indicate this pattern where higher levels of activity were detected in the

concentric trials in the most dorsiflexed positions (see Figure 5.4.3). Thirty minutes post-stretch, EMG recovery indicates that this pattern of activity was exacerbated as the recovery of MVIC-induced losses in EMG was 88.5% at 90% of ROM (most dorsiflexed position), 76.2% at 70% of ROM and only 39.5% at 50% of ROM (most plantarflexed position measured). Alternatively, these data may be suggestive of an inability to maintain neural activity of the α -motoneurone pool for prolonged periods of time (>5 -s; neurological fatigue) as the slow rotation during the concentric trials resulted in contraction durations of ~ 12 s. During the concentric trials MVC was maintained for ~ 12 -s, which may induce significant neurological fatigue. At 90% of ROM, MVC had been maintained for ~ 3.5 s increasing to ~ 5 s at 70% and ~ 6.5 s at 50% of ROM, which may be indicative of central fatigue and an inability to maintain neural activity of the α -motoneurone pool. Further research is required to determine whether the effects of the MVIC intervention were joint angle (muscle length) specific or whether the onset of neurological fatigue was shortened.

Whilst concentric joint moment and EMG activity recovered sufficiently after 30 min of rest so that they were no longer significantly depressed compared to pre-MVIC baseline, tendon stiffness and passive joint moment remained significantly depressed. Previously, stretch-based interventions have resulted in similar recovery patterns in active joint moment and EMG amplitude, however passive joint moment tended to fully recover to baseline (Fowles et al., 2000; Study 1 data). These disparate results in the recovery of passive moment may be explained by the different mechanical effects of these interventions on MTC tissues. The present data indicate that the reduction in passive joint moment after the MVICs was attributable to a decreased tendon stiffness, which remained apparent after 30 min. However, moderate duration (<5 min) stretch interventions (Study 1 data; Morse et al., 2008) have resulted in no change in tendon stiffness, with decreases in passive moment suggested to originate from a decreased muscle stiffness. Furthermore, the reduction in muscle stiffness appears to be transient, dissipating after 30 min indicating only a temporary effect of stretch to muscle stiffness (Study 1 data; Fowles et al., 2000). The continued depression of tendon stiffness after 30 min following MVICs, with concentric force recovery, may have important prophylactic injury implications as tendon stiffness (Hess, 1989) and muscle force (Orchard et al., 1997) have been associated with muscle strain injury risk. As previously discussed, the possible benefit of reduced tendon stiffness may have been negated as muscle force capacity was diminished. However, joint moment recovered after 30 min, thus removing this issue while tendon stiffness remained depressed, possibly maintaining its prophylactic effect. Further research is required to determine the long-term effects of MVICs on force production, MTC mechanics and muscle strain injury risk.

In summary, the present study is the first to specifically examine the effects of pre-stretch maximal isometric contractions (MVICs) as part of a comprehensive warm-up in order to determine the subsequent effect of stretch on joint moment, neuromuscular activity and MTC mechanics. Significant reductions in tendon stiffness, active (concentric) and passive plantarflexor joint moment and EMG amplitude occurred following the MVIC intervention. The

reduced concentric joint moment was unlikely to result from local muscle fatigue as there was no reduction in isometric force or change in EMG frequency. Significant correlations were found between the reductions in concentric joint moment and decreases in EMG amplitude, indicating that a substantial proportion of the reduction in force (~81%) could be attributed to a reduced neuromuscular activity. Although tendon stiffness was decreased, reductions in muscle operating length were clearly not a mechanism implicated with reductions in active force. An important finding of the present study was that no significant decrease in active or passive joint moment, EMG or MTC mechanics was evident when the MTC was then stretched passively for 3-min. This suggests that the use of MVICs in a warm-up routine might mitigate the widely reported negative effects of moderate duration stretch (< 3 min) within the plantarflexors but only because concentric force was already depressed. This finding has important implications both for research and warm-up intervention designs. The significant increase in active joint moment and EMG amplitude found 30 min after stretch suggests that physical tasks requiring high levels of plantarflexor muscle force are unlikely to be compromised at this time. However, decreased tendon stiffness and reduced passive joint moment remained, which may have important implications to injury risk for the triceps surae-Achilles muscle-tendon complex.

Chapter 5

Study 3

Concentric muscle contractions prior to static stretching minimise but do not remove stretch-induced force deficits

5.1. Abstract

The effects of concentric contractions and passive stretching on musculotendinous stiffness and muscle activity were studied in eighteen healthy human volunteers. Passive and concentric plantarflexor joint moment data were recorded on an isokinetic dynamometer with simultaneous EMG monitoring of the triceps surae, real-time motion analysis of the lower leg, and ultrasound imaging of the Achilles-medial gastrocnemius muscle-tendon junction. The participants then performed six 8-s ramped maximal voluntary concentric contractions (MVCCs) before repeating both the passive and concentric trials. Peak concentric moment was significantly reduced (6.6%; $P < 0.01$), which was accompanied by, and correlated with ($r = 0.60-0.94$; $P < 0.01$), significant reductions in peak triceps surae EMG amplitude (10.2%; $P < 0.01$). Achilles tendon stiffness was significantly reduced (11.7%; $P < 0.05$) but no change in muscle operating length was detected ($P > 0.05$). The participants then performed three 60-s static plantarflexor stretches before being re-tested 2 min and 30 min post-stretch. A further reduction in concentric joint moment (5.8%; $P < 0.01$) was detected post-stretch at 90% of ROM with no decrease in muscle activity or Achilles tendon stiffness but a significant increase in muscle operating length and decrease in tendon length was apparent at this ROM ($P > 0.05$). Thirty minutes after stretching, muscle activity significantly recovered to pre-MVCC levels, while concentric moment and Achilles tendon stiffness remained depressed. These data show that the performance of maximal concentric contractions can substantially reduce neuromuscular activity and muscle force, but this does not prevent a further stretch-induced loss in active plantarflexor joint moment. Importantly, the different temporal changes in EMG and concentric joint moment indicate that a muscle-based mechanism was likely responsible for the force losses post-stretch.

Keywords: Plantarflexor moment, concentric contractions, tendon stiffness, electromyography

5.2. Introduction

In the previous study (Chapter 4) it was shown that a series of maximal voluntary isometric contractions (MVICs) completely removed the effects of subsequent passive stretch on muscle-tendon mechanical properties, neuromuscular activity (EMG) and force production in the plantarflexors. This is despite the stretch protocol being identical to one that had previously resulted in significant changes in these measures (see Chapter 3). However, this apparent prophylactic effect occurred largely because the isometric contractions themselves had a detrimental effect on concentric force and neuromuscular activity. Consequently, the overall performance decrement from both the muscular contractions and stretch was similar to that found with passive stretching alone in these two studies. These changes are very similar to those that have been reported or hypothesised to occur after acute passive stretching (Avela et al., 1999, 2004, Cornwell et al., 2002; Cramer et al., 2005; Fowles et al., 2000). This is suggestive of stretching and isometric contractions having similar mechanical and neurophysiological effects on the muscle-tendon complex (MTC), which may explain apparent prophylactic effect of the isometric contractions on subsequent stretch. The significant changes seen after the performance of isometric contractions also suggest that the intervention may not be a useful pre-performance strategy even though it mitigates subsequent force deficits in response to stretch.

Although concentric force was decreased following the MVIC intervention (see Chapter 5), an encouraging finding was that the effects of the MVIC intervention were contraction-mode dependent, as no change in isometric force was evident. Given that any mechanical changes in the MTC would have been expected to influence both isometric and concentric force production, and that EMG was only reduced in the concentric trial, the effect of MVICs on neuromuscular activity appears also to be contraction mode-dependent. Furthermore, if peripheral mechanisms were responsible for the reductions in EMG (Avela et al., 1999), a decrease in isometric and concentric force would again be expected. These arguments leave central mechanisms (Cramer et al., 2004, 2005; Gandevia, 1992) as being most likely to underpin the reduction in neuromuscular activity during the concentric contraction mode. Thus the possibility exists that contractions of a different mode (e.g. concentric rather than isometric) might mitigate the effects of a subsequent period of passive stretch without first compromising neuromuscular activity and muscle force production.

Concentric contractions are commonly performed by athletic and clinical populations prior to intense physical activity, yet surprisingly, to the author's knowledge there are no data available to determine whether they have an influence on the commonly-described stretch-induced force reduction. Measuring neuromuscular changes in response to stretch subsequent to the application of an intervention that had measurable effects on the MTC would be an effective paradigm for elucidating the mechanisms that underpin the stretch-induced force deficit phenomenon. The results of such an examination would also inform best practice as to the design of research studies and optimise the structure of pre-performance routines, since concentric actions are sometimes performed during warm-up activities prior to strength testing.

Thus, the aim of the present study was to examine the effects of a series of maximal concentric plantarflexor contractions and a subsequent period of static muscle stretching (3 min) on Achilles tendon stiffness, gastrocnemius medialis muscle operating length, active (concentric) and passive ankle joint moment and neuromuscular (EMG) activity in the triceps surae MTC. Accordingly, the following hypotheses were developed:

Experimental Hypothesis 1

There will be a significant reduction in Achilles tendon stiffness, active and passive plantarflexor moment and EMG after the performance of maximal concentric contractions

Null Hypothesis 1

There will be no significant reduction in Achilles tendon stiffness, active and passive plantarflexor moment and EMG after the performance of maximal concentric contractions

Experimental Hypothesis 2

There will be a significant correlation between reductions in concentric moment and EMG after the performance of maximal concentric contractions

Null Hypothesis 2

There will be no significant correlation between reductions in concentric moment and EMG after the performance of maximal concentric contractions

Experimental Hypothesis 3

Further reductions in moment and EMG will not occur when static stretching is performed after a series of maximal concentric contractions

Null Hypothesis 3

Further reductions in moment and EMG will occur when static stretching is performed after a series of maximal concentric contractions

5.3 Methods

5.3.1. Participants

Eighteen active participants (9 women and 9 men; age = 21.0 ± 3.3 y, mass = 73.1 ± 16.4 kg, height = 1.7 ± 0.1 m) with no recent history of lower limb injury or illness volunteered for the study after giving written and informed consent. The participants were asked to refrain from intense exercise, flexibility training and stimulant use for 48 hr prior to testing. Ethical approval was granted by the Ethics Committee's of The School of Sport and Education at Brunel University and The School of Health at The University of Northampton in accordance with the declaration of Helsinki.

5.3.2. Protocol

The protocol was identical to study 2 (see Chapter 4) with the exception of employing concentric, rather than isometric contractions during the intervention. Equipment, processing, calculations and normalisation for peak concentric and passive ankle moment, ROM, neuromuscular activity (EMG), muscle and tendon length and stiffness were identical to Study 1 (see Chapter 3). The participants were initially familiarised with the testing protocol one week prior to data collection. During the experimental sessions, the participants performed a warm-up on a Monark cycle for 5-min at 60 revolutions/min with a 1-kg resistance load producing a constant 60 W power output. The participants were then seated in the chair of an isokinetic dynamometer (Biodex System 3 Pro, IPRS, Suffolk, UK) with the knee fully extended (0°), and the ankle placed in neutral position (0°) with the sole of the foot perpendicular to the shank, and positioned in the dynamometer footplate with the lateral malleolus aligned to the centre of rotation of the dynamometer. The participants' ankles were passively rotated through their full ranges of motion (ROM) at $0.087 \text{ rad}\cdot\text{s}^{-1}$ ($5^\circ\cdot\text{s}^{-1}$), before they performed a maximal concentric plantarflexor contraction at $0.087 \text{ rad}\cdot\text{s}^{-1}$ through their full ROM. The participants then performed six ramped maximal voluntary concentric plantarflexor contractions (MVCCs) before repeating the passive and active trials to determine whether there were any effects of the concentric contractions. Two minutes after completing the active trial, the participants' ankles were rotated (dorsiflexion) at $0.087 \text{ rad}\cdot\text{s}^{-1}$ to stretch the plantarflexors; three 60-s static plantarflexor stretches (see Chapter 3) were imposed with 60 s of rest after each stretch. The passive and active trials were then repeated 2 min and 30 min post-stretch to determine the impact of stretch. The order and time of the experimental protocol including the passive and concentric trials and isometric and stretch protocols is shown in Figure 5.3.1.

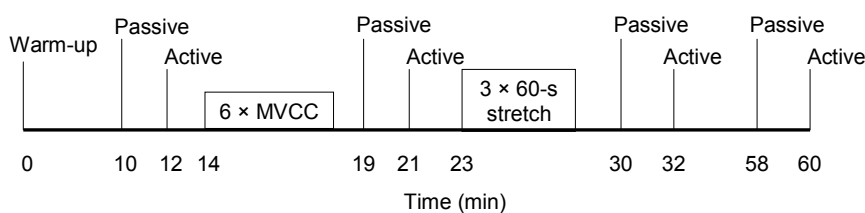

Figure 5.3.1. Timeline of the maximal voluntary concentric contractions (MVCCs) and stretch interventions.

5.3.3. Joint Moment during the passive trials

The participants were seated in the chair of an isokinetic dynamometer (Biodex System 3 Pro, IPRS) with the hip flexed to 55° and the knee fully extended (0°) and foot strapped into the dynamometer footplate. The participants' ankles were passively rotated at $0.087 \text{ rad}\cdot\text{s}^{-1}$ through their full ROM; the participants voluntarily terminated the rotation at the point of discomfort by pressing a hand held release button. Passive moment was recorded throughout the trial and then normalised to the maximum passive joint moment obtained in the first trial ($\%M_{\text{pas}}$). To account for inter-individual differences in joint flexibility/ROM, moment data were analysed at 50%, 70% and 90% of maximum ROM. Full ROM was calculated from the force trace inflection point, where a clear change in the slope of the passive moment curve occurred (see Figure 3.3.2), to peak dorsiflexion ROM.

5.3.4. Joint Moment during the concentric trials

The participants' ankles were rotated through their ROM at $0.087 \text{ rad}\cdot\text{s}^{-1}$ until reaching the point of discomfort. The participants then maximally contracted the plantarflexors until maximal isometric moment was reached (i.e. there was a visible plateau in the moment trace) before the footplate of the dynamometer was released at $0.087 \text{ rad}\cdot\text{s}^{-1}$. The participants continued to maximally contract the plantarflexors through their full ROM. Concentric plantarflexor moment was normalised to the maximum plantarflexor moment attained during the maximum voluntary isometric contraction ($\%M_{\text{VIC}}$). Maximal concentric moment was recorded throughout the full ROM but data were analysed only at 50%, 70% and 90% of the full ROM, calculated between full plantarflexion (0%) and full dorsiflexion (100%), to remove inter-individual variations in flexibility. During testing, joint moment, joint angle and angular velocity data for both passive and active trials were directed from the dynamometer to a high level transducer (model HLT100C, Biopac, Goleta, CA) before analogue-to-digital conversion at a 2000-Hz sampling rate (model MP150 Data Acquisition, Biopac). The data were then directed to a personal computer running AcqKnowledge software (v3.8.2, Biopac) and filtered with a double pass 6-Hz Butterworth low pass filter.

5.3.5. Concentric intervention

Two minutes after completing the maximal concentric trial, the participants' ankles were passively rotated from full plantarflexion at $0.087 \text{ rad}\cdot\text{s}^{-1}$ through their full ROM until reaching the point of discomfort. The dynamometer was then released at $0.087 \text{ rad}\cdot\text{s}^{-1}$ and the participants performed a ramped concentric plantarflexor contraction with maximum voluntary concentric contraction (MVCC) achieved approximately in the anatomical position. As the dynamometer continued to rotate the ankle through to full plantarflexion ($\sim 30^\circ$), the participants reduced the intensity of the contraction to full relaxation (total contraction time $\sim 8 \text{ s}$). This contraction pattern was employed to duplicate the work done in the previous isometric study (Chapter 4) where isometric contractions were performed in the anatomical position, to enable the

comparison of contraction-mode effects. The participants repeated the ramped contraction after 30 s of rest completing a total of six contractions during the concentric trial. During the familiarisation trials, the participants repeated the trial until they could consistently achieve a linear increase in joint moment, with MVCC achieved consistently near the anatomical position ($0 \pm 2.5^\circ$), followed by a linear decrease in moment over an 8 s timeframe. Passive and active trials were repeated two minutes after completing the contractions to determine any effects of the intervention.

5.3.6. Stretch intervention

The stretch protocol including duration and intensity was identical to Study 1 (see Chapter 3). Two minutes after completing the passive and active trials, the subjects' ankles were passively rotated at $0.087 \text{ rad}\cdot\text{s}^{-1}$ until reaching the point of discomfort. The subjects were then held in the stretched position for 60 s before being released at $0.087 \text{ rad}\cdot\text{s}^{-1}$, returning the foot to a fully plantarflexed position. The stretch protocol was repeated twice (after 60 s of rest) giving a total stretch duration of 3 min.

5.3.7. Electromyographic (EMG) recording

Site preparation, electrode placement, EMG sampling, processing and normalisation methods were identical to Study 1 (Chapter 3). Skin-mounted bi-polar double differentiated active electrodes (model MP-2A, Linton, Norfolk, UK) were positioned over the central portion of the muscle bellies of the soleus (Sol), medial gastrocnemius (GM), lateral gastrocnemius (GL) and tibialis anterior (TA). EMG amplitude was constantly monitored during the concentric trials to quantify muscle activity, and during passive trials to ensure the muscles were inactive. EMG signals were amplified (gain = 300, input impedance = $10 \text{ G}\Omega$, CMRR = $> 100 \text{ dB}$ at 65 Hz) and then directed to a high level transducer (model HLT100C, Biopac) before analogue-to-digital conversion at a 2000-Hz sampling rate (model MP150 Data Acquisition, Biopac). The signals were directed to a personal computer running AcqKnowledge (v3.8.2, Biopac) software and filtered using a 20- to 500-Hz band-pass filter. The filtered signal was converted to root mean squared (RMS) EMG with a 250-ms sample window, and then normalised as a percentage of the peak amplitude recorded during a maximal voluntary isometric contraction. The normalised EMG amplitude ($\%_{\text{MVIC}}$) was used as a measure of neuromuscular activity; the EMG signals for Sol, GM and GL were averaged to obtain an amplitude representative of the triceps surae (TS) muscle group activity. The antagonist tibialis anterior (TA) EMG data were processed and normalised using the same method. The normalised joint moment and normalised TS EMG amplitude were used to calculate the EMG:moment ratio. A fast fourier transformation (FFT) of a 1 s sample of the filtered (non-RMS) EMG was used to calculate the mean and median EMG frequency at 90% of ROM.

5.3.8. Gastrocnemius medialis (GM) muscle length and Achilles tendon length and stiffness

The methods for measuring GM muscle length and Achilles tendon length and stiffness were identical to Study 1 (Chapter 3). Movement of the ankle in the dynamometer footplate was recorded during the passive, concentric and stretch trials using real-time motion analysis with three infrared digital cameras (ProReflex, Qualisys, Gothenburg, Sweden) operating Track Manager 3D software (v.1. 8.226, Qualisys). These recorded the position and movement of infrared reflective markers placed over the medial femoral epicondyle, representative of the origin of the medial gastrocnemius (see Figure 3.3.8; *marker A*), and over the calcaneum, representative of the insertion of the Achilles tendon (*marker B*). Ultrasound imaging was used to locate the GM-Achilles musculotendinous junction (MTJ) and a third marker (*marker C*) was placed over the MTJ position aligned with adhesive zinc-oxide hypoechoic tape. Data were sampled at 100-Hz and raw coordinate data were smoothed using a 100-ms averaging window prior to the calculation of Achilles tendon and GM muscle lengths.

The position and excursion of the GM-Achilles muscle tendon junction (MTJ) were recorded using real-time ultrasound video imaging (LOGIQ Book XP, General Electric, Bedford, UK) from a wide-band linear probe (8L-RS, General Electric) with a 39 mm wide field of view and coupling gel (Ultrasound gel, Dahlhausen, Cologne, Germany) between the probe and skin. The probe was orientated with the proximal end towards the origin of the medial head and the distal end positioned towards the insertion of the tendon. The position of the probe was manipulated until the deep aponeurosis between GM and Sol could be visualised and then the probe was affixed with zinc-oxide adhesive tape perpendicular to the skin. Ultrasound images were sampled at 28 Hz and the MTJ and hypoechoic tape (indicative of reflective *marker C*) positions were manually digitised at 4.67 Hz (Peak Motus, Englewood, CO). Raw coordinate data were smoothed using a 100-ms moving average before calculation of the distance between the MTJ and hypoechoic tape. Data from the dynamometer, motion analysis and ultrasound systems were synchronised using a 5-V ascending transistor-transistor linear (TTL) pulse, which was exported to the AcqKnowledge software (v3.8.2, Biopac) and triggered the capture of the ultrasound data. GM muscle length was calculated as the distance between reflective *markers B* and *C* (see Figure 3.3.8), plus the distance from actual MTJ position (determined with ultrasound; see Figure 3.3.12). Tendon length was calculated as the distance between reflective *markers A* and *C*, minus the distance from actual MTJ position. Tendon stiffness was calculated by dividing tendon length change by the change in ankle moment at 90% of ROM (mean = $6.2 \pm 6.8^\circ$ dorsi flexion).

5.3.9. Data Analysis

All data were analysed using SPSS statistical software (v.11.5; LEAD Technologies Inc., USA); group data are reported as means \pm SE and temporal (i.e. change) data are reported as means \pm SD. All data were initially screened to test for assumptions of normal distribution using Kolmogorov-Smirnov and Shapiro-Wilks, which revealed no significant effect ($P > 0.05$)

indicating the data were normally distributed. As repeated measures experimental designs were employed, the further assumption of sphericity needed to be determined. Where Mauchly's test of sphericity revealed no significant effects ($P > 0.05$), the sphericity assumed F ratio was used to determine significant differences between groups. Where sphericity was violated ($P < 0.05$), the Greenhouse-Geisser value was used to obtain the F ratio to determine significance. Multiple analyses of variance (MANOVA) with repeated measures were used to test for differences in EMG mean and median frequencies. Separate analyses of variance (ANOVA) with repeated measures were used to test for differences in 1) concentric and passive plantarflexor moment, 2) EMG amplitude and EMG:moment ratio, and 3) GM muscle and Achilles tendon lengths and tendon stiffness. Pearson's product moment correlation was used to determine the relationship between post-MVCCs reductions in moment and changes in EMG amplitude. Consistent with statistical procedures (Field, 2005), Bonferroni correction was applied during the post hoc analysis, where this proved too conservative (masked the location of the difference), Tukey's LSD was applied (specific correction used is reported with each data set). Statistical significance for all tests was accepted at $P < 0.05$.

5.3.10. Reliability

Test-retest reliability for the methods and measures were calculated in pilot testing and during the control condition in Study 1 (see Chapter 3).

5.4. Results

As reported in the previous chapter, the same participants, measures and testing protocol (with the exception of different interventions) were employed in each study within the thesis, therefore control condition data were used from the first study to establish reliability of the measures. During the no stretch condition (control), no significant difference in any measure at any joint ROM was detected following 5 min of complete rest ($P > 0.05$; see Chapter 3).

The current study protocol included two interventions: 1) 6 maximal voluntary concentric contractions (MVCCs) followed by 2) 3 min of passive static stretching; and examined the impact of these interventions on several measures. For clarity, given the number of analyses undertaken, the results have been separated into sections devoted to each measure.

5.4.1. Changes in concentric joint moment after concentric contractions and 3-min of passive stretch (hypothesis 1 and 3)

There was a significant reduction in concentric joint moment detected at 50% ($F = 7.54$; $P < 0.001$), 70% ($F = 6.67$; $P < 0.01$) and 90% ($F = 11.48$; $P < 0.001$) of ROM (see Appendix 3; Table 5.4.1). Post hoc t-test analyses with Bonferroni correction revealed significant reductions (mean = $6.6 \pm 1.0\%$; $P < 0.01$) immediately post-MVCC at all joint angles (see Figure 5.4.1). There was a further reduction ($P < 0.05$) in concentric joint moment at 90% ROM from pre- to post-stretch but not at other joint angles. No recovery in joint moment occurred 30 min later and remained significantly reduced (mean = $9.2 \pm 1.2\%$; $P < 0.01$) when compared to pre-MVCC data (see Figure 5.4.1).

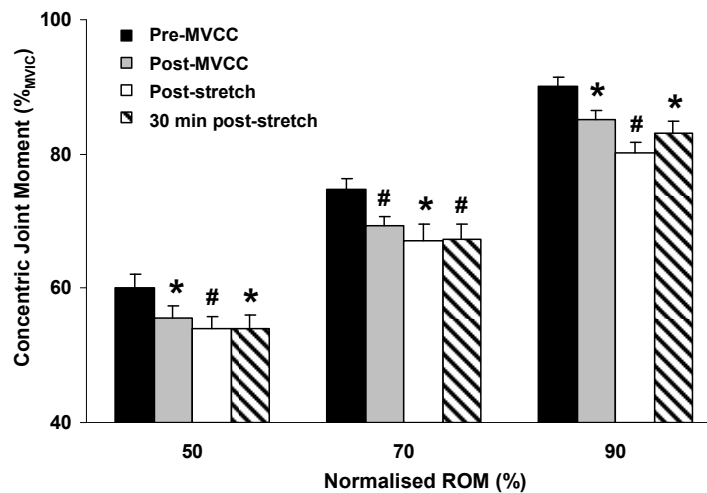

Figure 5.4.1. Normalised moment during maximal concentric plantarflexion trials measured at 50%, 70% and 90% of ROM. *Significant to $P < 0.05$, #significant to $P < 0.01$ compared to pre-MVCC group.

5.4.2. Changes in EMG after concentric contractions and 3-min of passive stretch (hypothesis 1 and 3)

There was a significant reduction in peak TS EMG amplitude detected at 50% ($F = 3.03$; $P < 0.05$), 70% ($F = 7.27$; $P < 0.001$) and 90% ($F = 13.53$; $P < 0.001$) of ROM with similar reductions ($P < 0.05$) in all EMG amplitudes (GL, GM & Sol) also detected (see Appendix 3; Table 5.4.2). A significant difference was also detected in TS EMG:moment ratio at 50% ($F = 11.77$; $P < 0.001$), 70% ($F = 16.70$; $P < 0.001$) and 90% ($F = 26.16$; $P < 0.001$) of ROM. No change was detected ($P > 0.05$) in the mean (pre-MVCC = 222.9 ± 5.1 Hz, post-MVCC = 228.9 ± 4.1 Hz; $P > 0.05$, TS EMG) or the median (pre-MVCC = 128.0 ± 5.0 Hz, post-MVCC = 128.3 ± 4.5 Hz; $P > 0.05$, TS EMG) frequency of any EMG signal.

Post hoc t-test analyses with Bonferroni correction revealed a significant decrease in peak TS EMG amplitude ($10.2 \pm 3.1\%$) immediately post-MVCC at all joint angles (see Figure 5.4.2). Similar reductions ($P < 0.05$) in all EMG amplitudes (GL mean = $8.0 \pm 3.8\%$; GM mean $15.0 \pm$

2.3%; Sol mean = $7.8 \pm 4.2\%$) were detected. No significant change in TA EMG amplitude ($P > 0.05$) was detected, suggesting that the MVCC intervention did not impact neuromuscular coactivity. There was no change ($P > 0.05$) in any EMG amplitude at any ROM from pre- to post-stretch, indicating that the stretch protocol did not impact upon neuromuscular activity. However, EMG amplitude increased 30 min later at all joint angles (see Figure 5.4.2), and recovered sufficiently so that it was no longer significantly depressed relative to the pre-MVCC group (GL = $0.6 \pm 1.1\%$; GM = $3.3 \pm 2.9\%$; Sol = 1.3 ± 5.0 ; TS = $2.0 \pm 2.2\%$).

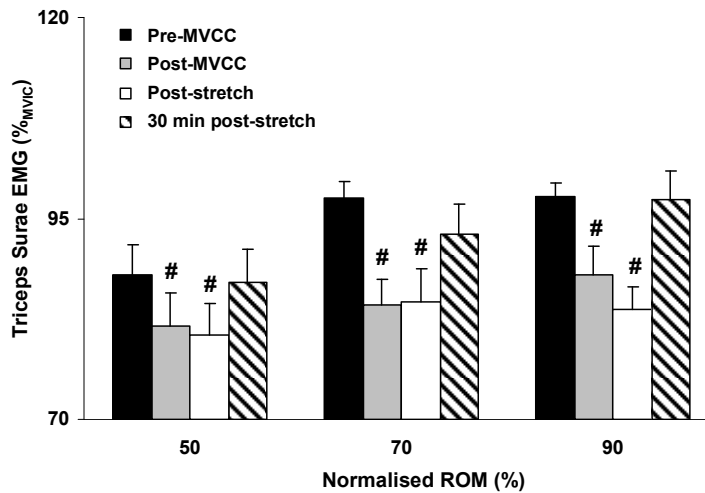

Figure 5.4.2. Normalised triceps surae (TS) electromyographic (EMG) amplitude during maximal concentric plantarflexion trials measured at 50%, 70% and 90% of ROM. #Significant to $P < 0.01$ compared to pre-MVCC group.

Interestingly, post hoc t-test analyses with Bonferroni correction revealed a significant increase in the EMG:moment ratio at all joint angles (see Figure 5.4.3) 30 min post-stretch compared with all other group data ($10.5 \pm 2.2\%$; $P < 0.01$), which is attributable to the full recovery in EMG while joint moment remained significantly impaired ($9.2 \pm 1.2\%$; $P > 0.01$).

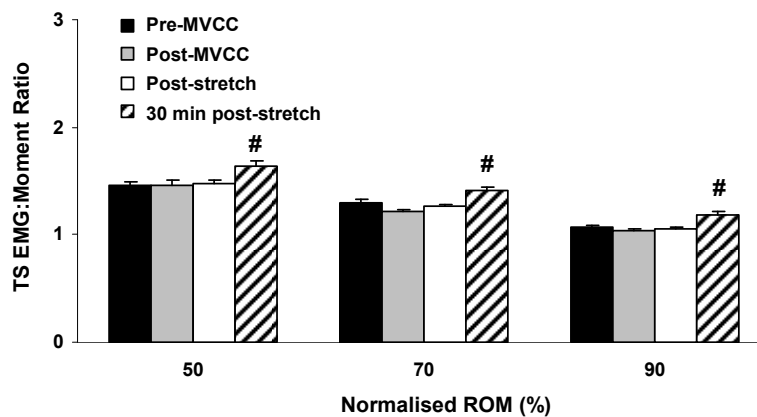

Figure 5.4.3. Triceps surae (TS) electromyographic (EMG):moment ratio during maximal concentric plantarflexion trials measured at 50%, 70% and 90% of ROM. #Significant to $P < 0.01$ compared to pre-MVCC group.

5.4.3. EMG: Moment correlation (hypothesis 2)

Pearson's product moment correlations computed between changes in triceps surae EMG amplitude and decreases in joint moment were significant at 50% ($r = 0.60$; $P < 0.05$), 70% ($r = 0.78$; $P < 0.01$) and 90% ($r = 0.94$; $P < 0.001$) of ROM (see Figure 5.4.4), indicating that the participants who had the greater reductions in EMG tended also to exhibit the greatest loss of active joint moment. Similar correlations were also revealed in GL, GM and Sol EMG ($P < 0.05$; data not shown). However, in agreement with data from studies 2 & 3 (Chapters 4 & 5), the averaging of individual muscle EMG amplitudes to create a single EMG amplitude representative of the triceps surae muscle group (TS EMG) generated the strongest EMG correlations with reductions in moment at all joint angles. As no significant increase in joint moment occurred 30 min later, correlations between the increases observed in EMG 30 min later were not computed.

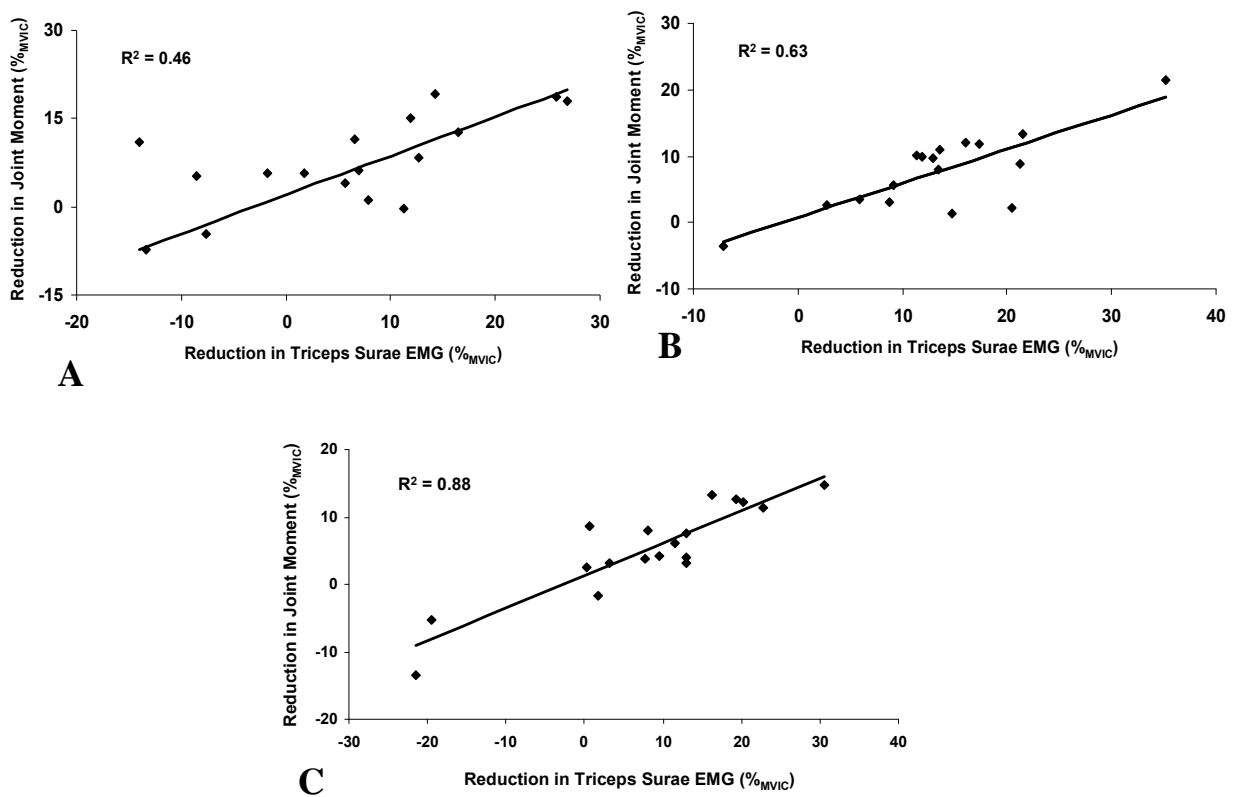

Figure 5.4.4. Correlations between post-maximal voluntary concentric contractions (MVCCs) reductions in concentric joint moment and triceps surae (TS) electromyographic (EMG) amplitude (A = 50%; B = 70%; C = 90% of ROM).

5.4.4. Changes in passive joint moment after concentric contractions and 3-min of passive stretch (hypothesis 1 and 3)

During the passive trials a significant reduction in joint moment was detected at 50% ($F = 9.61$; $P < 0.01$), 70% ($F = 12.73$; $P < 0.001$) and 90% ($F = 12.15$; $P < 0.001$) of ROM (see Appendix 3; Table 5.4.3). Post hoc t-test analyses with Bonferroni correction revealed a trend toward a reduced joint moment post-MVCC at 50% and 70% of ROM, which became significant (3.9%; $P < 0.01$) at 90% of ROM (see Figure 5.4.5). A further significant reduction in moment was detected immediately post-stretch at 90% of ROM when compared to the post-MVCC group. Further reductions were then detected at 50% and 70% of ROM immediately post-stretch when compared to the pre-MVCC group (see Figure 5.4.5). Passive joint moment increased significantly at 30 min post-stretch (see Fig. 5.4.5) at all joint angles ($P < 0.01$) when compared to post-stretch data, and was no longer significantly reduced when compared to baseline ($1.7 \pm 1.4\%$; $P > 0.05$).

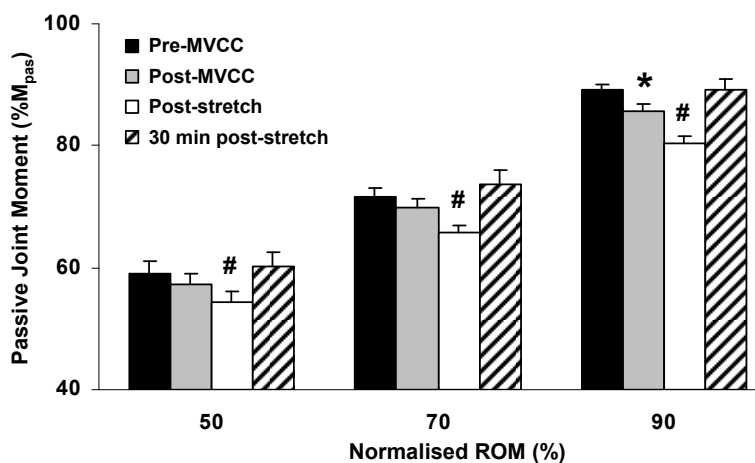

Figure 5.4.5. Joint moment during passive trials measured at 50%, 70% and 90% of ROM. *Significant to $P < 0.05$, #significant to $P < 0.01$ compared to pre-MVCC group.

5.4.5. Achilles tendon length and stiffness and GM muscle length during the concentric trials (hypothesis 1 and 3)

There was a significant reduction in tendon stiffness ($F = 7.8$; $P < 0.01$), tendon length ($F = 4.68$; $P < 0.01$) and increase in muscle length ($F = 4.21$; $P < 0.01$) detected at 90% of ROM during the concentric trial (see Appendix 3; Table 5.4.4). Post hoc t-test analyses with Bonferroni correction revealed a significant reduction ($P < 0.01$) in Achilles tendon stiffness immediately post-MVCC ($11.7 \pm 3.7\%$; $P < 0.01$) from 10.3 ± 1.6 Nm/mm pre-MVCC to 8.9 ± 0.9 Nm/mm post-MVCC (calculated at 90% of ROM; see Figure 5.4.6) during the concentric contraction. Because of the decrease in tendon stiffness, the magnitude of length change of the tendon during contraction (pre-MVCC = 15.0 ± 1.7 mm; post-MVCC = 16.0 ± 1.3 mm) was similar despite the lower muscle force ($6.6 \pm 1.0\%$); reliability of these methods to detect significant change in tendon length were modelled and have been described previously (see Chapter 3). No further change in tendon stiffness was detected immediately or 30 min post-

stretch, indicating stretch had no further impact on tendon stiffness. The reduced stiffness remained 30 min later. Again, consistent with the further reduction in concentric moment post-stretch described previously at 90% of ROM, a trend towards a reduction in tendon length and increase in GM muscle length was also detected post-stretch, which was significant at 90% of ROM. This is reflective of the reduced force transmitted through the tendon (see Figure 5.4.6).

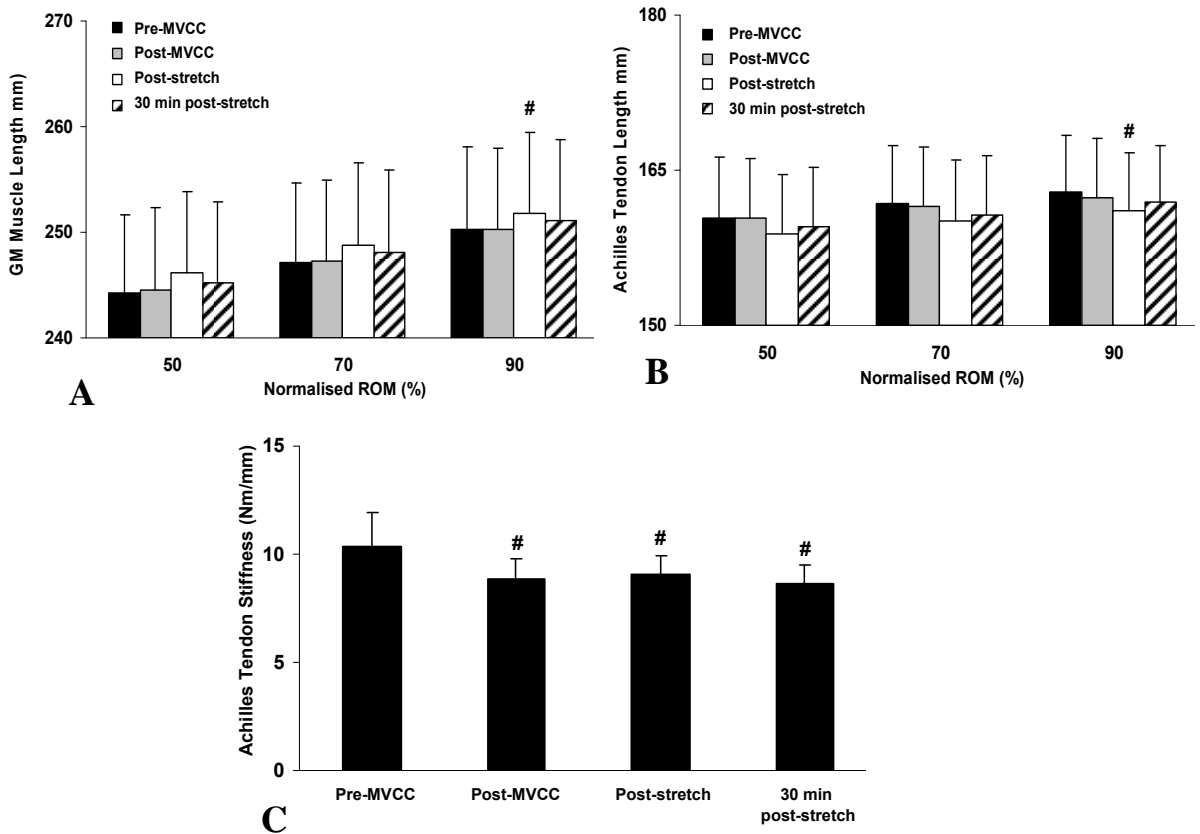

Figure 5.4.6. Achilles tendon length (A), gastrocnemius medialis (GM) muscle length (B) and Achilles tendon stiffness (C) calculated during the concentric trials measured at 50%, 70% and 90% of ROM. #Significant to $P < 0.01$ compared to pre-MVCC group.

5.4.6. Achilles tendon length and stiffness and GM muscle length during the passive trials (hypothesis 1 and 3)

A significant difference in Achilles tendon length ($P < 0.05$) was detected at all joint angles and in GM muscle length ($P < 0.05$) at 50% of ROM (see Appendix 3; Table 5.4.5). Consistent with the reduced Achilles tendon stiffness findings, post hoc t-test analysis with Bonferroni correction revealed a significant increase in Achilles tendon length ($0.8 \pm 0.1\%$; $P < 0.05$) at all joint angles (see Figure 5.4.7) post-MVCC and a trend towards decreased muscle length, which was significant at 50% of ROM ($0.4 \pm 0.1\%$; $P < 0.05$) post-MVCC.

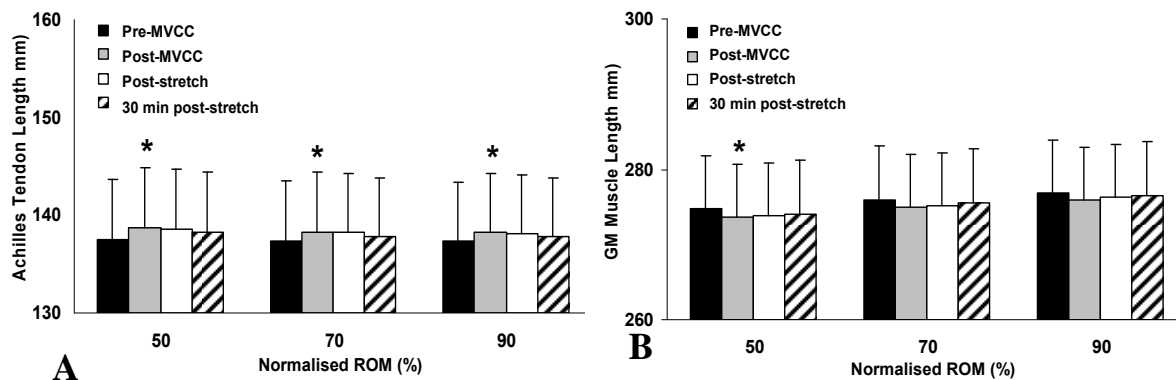

Figure 5.4.7. Achilles tendon length (A) and gastrocnemius medialis (GM) muscle length (B) during the passive trials measured at 50%, 70% and 90% of ROM. *Significant to $P < 0.05$ compared to pre-MVCC.

5.5. Discussion

The aim of the present study was to determine whether the performance of maximal voluntary concentric contractions (MVCCs) influenced the effects of a subsequent passive stretch protocol on Achilles tendon stiffness, neuromuscular activity (EMG) and concentric joint moment. Following the MVCC intervention concentric joint moment was significantly reduced ($P < 0.01$), which was accompanied by, and correlated with ($r = 0.60 - 0.94$; $P < 0.01$), reduced triceps surae EMG amplitude ($P < 0.01$). Achilles tendon stiffness was significantly reduced ($P < 0.01$) when measured during the concentric contractions, but there was no change in GM muscle operating length ($P > 0.05$) as the reduced tendon stiffness enabled the tendon to deform to a similar length under significantly less muscle force. During the passive trials, a significant increase in Achilles tendon length ($P < 0.01$) and decrease in GM muscle length ($P < 0.01$) was detected. A trend toward reduced passive joint moment was apparent at 50% and 70% of ROM which became significant at 90% of ROM ($P < 0.01$). Following the subsequent stretch intervention, a trend toward reduced concentric joint moment was apparent at 50% and 70% of ROM which became significant at 90% of ROM ($P < 0.01$). There was no reduction in EMG amplitude or tendon stiffness ($P > 0.05$), however, Achilles tendon length was significantly reduced ($P < 0.01$). A significant decrease in passive joint moment ($P < 0.01$) was found post-stretch at all joint angles, which can most likely be explained by a decreased muscle stiffness. Finally, the changes induced by the MVCC and stretch interventions in EMG amplitude and passive joint moment were reversed following 30 min of passive rest, however no significant recovery in concentric joint moment and Achilles tendon stiffness was apparent. Given these findings the first hypothesis that there would be a significant reduction in Achilles tendon stiffness, active and passive plantarflexor moment and EMG post-MVCCs can be accepted. The second hypothesis that there would be a significant correlation between post-MVCCs reductions in concentric moment and EMG can be accepted. Finally, the third hypothesis that the stretch-mediated reductions in moment and EMG would be removed following MVCCs can be partially accepted.

The main finding from the present study was that the 6-repetition MVCC protocol itself significantly impaired active concentric plantarflexor moment production, but then the subsequent 3-min static stretch intervention resulted in further losses of muscular force. The performance of isometric contractions in study 2 (Chapter 4) resulted in a similar reduction in concentric force but, unlike the concentric contractions in the present study (which were of a similar duration and volitional intensity), those isometric contractions completely removed the subsequent effects of stretch. Perhaps of even greater significance was that although there was less total decline in concentric moment following the concentric contraction-stretch combination (10.4%; present study) than previously shown for the isometric contraction-stretch combination (13.4%; Chapter 5), the significant reduction in concentric moment remained after a 30-min rest period when concentric contractions preceded the stretching (9.2%; present study). The implications of these findings are substantive for the design of research studies as the warm-up imposed on participants prior to the stretch seems to strongly influence the stretch-induced loss of force. Discrepant findings between previous studies could have conceivably occurred through the choice of different warm-up routines. Although there are a number of methodological differences between studies, it is interesting to note that several studies that included repeated contractions prior to stretch (Behm et al., 2004; Cramer et al., 2006, Egan et al., 2006) reported no effect of stretch, whereas studies omitting these contractions reported significant reductions in muscular performance (Cornwell et al., 2002; Fowles et al., 2000; Weir et al., 2005). These results also have important practical implications for the formulation of pre-performance routines in normal, athletic and clinical populations where maximal force production within the plantarflexors is an important performance component; the performance of maximal concentric contractions does not completely abolish the stretch-induced decline, but seems to be associated with a lesser recovery of the force after stretch.

The performance of maximal contractions prior to the testing of peak muscle strength and power has previously been reported to enhance force production (Baudry & Duchateau, 2007; Chiu et al., 2003; Gilbert & Lees, 2005; Hamada et al. 2003; O'Leary et al., 1997), a phenomenon termed post-activation potentiation (PAP). However, their efficacy in this regard is debated due to equivocal reports in the literature (Chiu et al., 2003; Gossen & Sale, 2000; Hrysmallis & Kidgell, 2001). Furthermore, significant reductions in force and EMG activity have also been reported following similar intermittent contractions (Taylor et al., 2000a). Following the series of maximal contractions performed in the present study, a significant reduction in joint moment and EMG amplitude was detected, clearly indicating that PAP did not occur and that some level of fatigue was induced. Interestingly, Chiu et al. (2003) reported that while PAP occurred in a highly trained athlete group, no potentiating effect was detected within a recreationally active group. Considering the participant demographic used in the present study (recreationally active), the present data are consistent with those of Chiu et al. (2003). Typically, the reduced concentric moment might be explained by metabolic fatigue induced by the MVCC intervention, however this is unlikely as the intermittent contractions would not have induced local muscular ischemia (Taylor et al., 2000a). Furthermore, the clear reduction in EMG amplitude was highly correlated ($r = 0.94$) with the decrease in joint moment, which is

suggestive of an inability of the participants to activate the α -motoneurone pool rather than a decrease in muscle force at a given level of activation. Furthermore, there was no change in the mean or median EMG frequencies, which would be expected to decrease if muscular fatigue was present (Cifrek et al., 2009). Increased peripheral inhibition (Avela et al., 1999) of the α -motoneurone pool from type 1b muscle afferents (golgi tendon organs), possibly as a result of the decreased tendon stiffness, may explain the reduced EMG activity. However, this too is unlikely as a similar isometric intervention used in the previous study (Chapter 4), which significantly reduced tendon stiffness, resulted in no change in isometric force despite both concentric force and EMG being reduced. Therefore, these data are likely to be indicative of a decrease in central neural drive (Cramer et al., 2004, 2005; Gandevia, 1992; Taylor et al., 2000a). Although this has been reported following intermittent maximal contractions of similar repetition and duration (Taylor et al., 2000a), the present methods did not enable the location (i.e. spinal or supraspinal) of the reduced descending neural drive to be determined. Further research is required to reveal the location of the mechanisms underpinning the losses in EMG activity.

Importantly, despite there being a reduction in tendon stiffness after the MVCCs (measured during the concentric contractions), there was no change in the operating length of gastrocnemius medialis (GM). Assuming that GM muscle length is indicative of the whole triceps surae length, the decreased active concentric moment recorded after the MVCCs could not be explained by a reduced operating length of the triceps surae affecting their force-length properties (Maganaris 2001, 2003). This finding is consistent with the previous studies in the thesis, where no reduction in muscle length after stretch (Chapter 3) or muscle contraction (Chapter 4) interventions was detected. Therefore, altered force-length properties commonly hypothesised as a mechanism underpinning reductions in joint moment (Cramer et al., 2004, 2007; Fowles et al., 2000; Kay & Blazevich, 2008; Nelson et al., 2001a, 2001b, Weir et al., 2005) can be removed.

Probably the most intriguing finding of the present study was that 3 min of stretch resulted in a further decrease in concentric moment, which was accompanied by an increase in muscle operating length (i.e. a decrease in tendon length) but not a further decrease in EMG amplitude. Thus, after concentric muscle actions it seems possible that muscle force generating capacity can be compromised by stretching even when there is no reduction in neuromuscular activity. Similar decreases in muscle force production without a change in EMG have been previously reported after an acute bout of static stretching (Evetovich et al., 2003; Kay & Blazevich, 2008; Weir et al., 2005), but the present thesis showed that the present stretch protocol reduced concentric moment concomitantly with a decrease in EMG when stretching is performed in isolation (Chapter 3), or to have no effect on either active moment or EMG when it is performed after a series of isometric contractions (Chapter 4). Indeed, in addition to the stretch protocol being identical between these studies, the same participant sample was recruited for the present study, which improves the confidence in the comparisons. Also, the concentric contractions conducted in the present study involved the performance of an 8-s contraction with

joint moment increasing to maximum after 4 s and then decreasing to full relaxation by 8 s. This facilitates the comparison of results to those of the previous study (Chapter 4) where isometric contractions were performed with a 4-s increase to maximum and then a 4-s decrease to full relaxation. Importantly, joint moment remained significantly depressed 30 min later (9.2% compared to baseline), despite EMG recovering fully, which resulted in the significant increase in the EMG:moment ratio ($10.6 \pm 2.2\%$; $P < 0.001$). Thus, while a decrease in neuromuscular activity might be reflective of, or associated with, other changes that might impact on force generation capacity, it does not seem that a reduced activity was either the main cause of the additional force decline detected post-stretch in the present study, or the maintenance of these losses 30 min later.

Although reduced neuromuscular activity was associated with the initial reduction in joint moment following the concentric intervention, it was clearly not a mechanism underpinning the additional losses incurred post-stretch or the maintenance of these losses 30 min later. Plantarflexor joint moment and EMG have previously been shown to recover after 30 min when stretching was performed in isolation (Avela., 1999; Fowles et al., 2000; Chapter 4) and when stretching was preceded by a series of isometric contractions (Chapter 5). However, the additional losses in joint moment found post-stretch in the present study occurred without any change in EMG. Similar post-stretch reductions in joint moment, without any change in EMG, have been reported previously (Evetovich et al., 2003; Kay & Blazevich, 2008; Weir et al., 2005). Unfortunately these studies did not determine the temporal effects of stretch, which limits our ability to determine whether these losses were transient. In the absence of any change in neuromuscular activity, muscle-based hypotheses have been suggested to partially explain these post-stretch force losses. The significant reduction in passive moment detected post-stretch in the present study was attributed to reduced muscle stiffness, in agreement with other studies (Morse et al., 2008) and the findings of Study 1 (Chapter 3). This could be explained by the thixotropic properties of muscle tissue where muscle stiffness can be affected by prior contraction or stretch history (Lakie et al., 1984; Morgan et al., 1984; Proske et al., 1993, 1999), although Morse et al. (2008) suggested that this was an unlikely mechanism able to explain the reduction in muscle stiffness. Alternatively, the reduced stiffness may be indicative of damage to the muscular cytoskeleton, which could affect contractile behaviour (Yeung et al., 2002), calcium infiltration (Armstrong et al., 1993; Lamb et al., 1995) and the excitation-contraction coupling process (Bruton et al., 1996; Lamb et al., 1995), which may explain the reduced force generation. Regardless, the specific impairment to this process remains unknown and further research is required, although the mechanism underpinning the maintenance of these force losses appear not to be of neurological origin.

In summary, the effects of concentric contractions (MVCCs) and passive stretch on joint moment, neuromuscular activity and MTC mechanics were examined. In agreement with the previous isometric intervention study (Chapter 4), significant reductions were detected in concentric joint moment and EMG amplitude post-MVCC. Furthermore, the significant correlation ($r = 0.94$) between reductions in joint moment and reduced muscle EMG amplitude

were in agreement with the previous findings ($r = 0.90$; Chapter 5) that reduced neuromuscular activity was the most likely mechanism underpinning these losses. The absence of any change in the frequency content of the EMG signal is suggestive of central mechanisms affecting the activation of the α -motoneurone pool. Importantly, a further reduction in concentric joint moment was found post-stretch when no change in EMG occurred; 30 min later EMG fully recovered while concentric moment remained impaired, implicating a muscle-based mechanism underpinning these additional force losses. These findings have important implications for research study design as the warm-up imposed on participants prior to stretch seems to strongly influence the impact of stretch. Furthermore, the results also have important practical implications in the formulation of pre-performance routines in normal, athletic and clinical populations where maximal force production in the plantarflexors is an important goal.

Chapter 6

General Discussion of the Present Research

Static stretching within a warm-up routine prior to intense physical activity is regularly performed in clinical, recreationally active and athletic populations (Bishop, 2003). However, recent reports that acute static stretch can induce significant decrements in force and power production (e.g. Cramer et al., 2007; Siatras et al., 2008) and increased scrutiny following equivocal support from research as to their influence on injury risk (Gleim & McHugh, 1997; Thacker et al., 2004; Weldon & Hill, 2003; Witvrouw et al., 2004) have called this practice into question. Although the post-stretch force deficit phenomenon is well documented, several issues remain as to the mechanisms that underpin it plus its influence as part of an extended pre-performance routine. First, much of the research utilised stretch durations far in excess of normal pre-performance activities (> 10 min), whilst there are equivocal reports as to the effects on force production when shorter duration stretch is applied (~ 2 min; Behm et al., 2004; Cramer et al., 2006; Magnusson et al., 1998, 2000; Muir et al., 1999). Second, the mechanisms underpinning these losses are unclear, with reduced neuromuscular activity (Avela et al., 1999, 2004, Fowles et al., 2000) and changes in the mechanical properties of the MTC affecting muscle operating length (Cramer et al., 2004, 2007; Fowles et al., 2000; Kay & Blazevich, 2008; Nelson et al., 2001a, 2001b, Weir et al., 2005) commonly implicated. While concomitant reductions in force and EMG have been reported, no correlation analyses have been conducted to determine the strength of any relationship between EMG decrements and reductions in active force. Furthermore, while changes in muscle length during contraction have also been suggested as a mechanism underpinning the force losses, no study has specifically examined this contention. Reductions in passive moment have led some authors to speculate that a decrease in the stiffness of the tendon might occur with stretching, which would cause the muscle to operate at a shorter, less optimal length. However, the location of any impairment of MTC mechanics requires further examination as equivocal reports exist identifying reductions in both muscle (Morse et al., 2008) and tendon (Kubo et al., 2001a) stiffness, although differences in study design do not enable direct comparison between these studies.

Given the current limitations in the research, the effects of an acute bout of moderate-duration (3 min) static stretch on concentric and passive plantarflexor joint moment, neuromuscular activity (EMG), Achilles tendon stiffness and muscle operating length were examined in the first study (Chapter 3). A significant reduction in concentric plantarflexor joint moment was detected immediately post-stretch, which was correlated ($r = 0.81$; $P < 0.01$) with a reduction in EMG amplitude. Although concomitant reductions in force and EMG amplitude have been reported previously, the strength of the relationship between changes in EMG and changes in force has not previously been determined. The strong correlations are indicative of the reductions in force

being largely attributable to an inability to activate the α -motoneurone pool or a reduced propagation along the sarcoplasmic reticulum (Cifrek et al., 2009). Importantly, no reduction in Achilles tendon stiffness or GM muscle operating length was found, removing this mechanism as a factor underpinning the force losses. A significant reduction in passive moment was also found. Given that no change in tendon stiffness was detected, this decrease in passive moment is reflective of a reduced muscle stiffness. The possibility exists that reduced muscle stiffness is indicative of microtrauma to the cytoskeletal network, which could impact structures including the sarcoplasmic reticulum (Bruton et al., 1996; Lamb et al., 1995) or transverse-tubular network (Yeung et al., 2002) and ultimately affect the excitation-contraction (EC) coupling process and attenuate force production. Examination of changes in M-wave amplitude and changes in fibre conduction velocity would provide information on this possibility and further research is required to examine this hypothesis. Regardless, the findings that reductions in EMG were strongly associated with the decreases in force, while no change in muscle operating length was detected, represent a major step forward in our understanding of the mechanisms underpinning the post-stretch force deficit phenomenon. Importantly, no significant deficits in any measure were found 30 min post-stretch, suggesting the effects of these shorter duration stretches (3 min in total) were transient. This finding is important because the performance of physical tasks requiring high levels of plantarflexor muscle force is unlikely to be compromised following moderate-duration passive stretch. The previously reported negative impact of stretch on force production might be of lesser practical importance when tasks are performed at a reasonable time period (~30 min) after the stretch and pre-performance routines could be designed with this in mind.

A possible limitation of previous studies is that of the effects of stretch were examined in isolation, without also including either/or a sufficient warm-up period or strong muscle contractions prior to the testing. This makes it difficult to then draw conclusions for athletic or clinical populations as to the effects of stretching in a pre-performance routine. The examination of an intervention (stretch) in isolation, when multi-intervention warm-up protocols are commonly employed, may limit the external validity of these studies. Equivocal reports on the effects of static stretch exist in the literature; however, a review of the stretch-based studies indicates that some of the disparity may be attributable to significant differences in experimental study design, and in particular whether an intense warm-up preceded the stretch intervention. Ninety two percent of studies examined in the present thesis (see Chapter 2; Table 2.7.1) reported a decrease in force or power when an intense warm-up regime including strong muscular contractions was not performed, however this decreased to 50% when stretching was imposed after an intense warm-up including maximal contractions (see Chapter 2; Table 2.7.2). While reductions in force have been reported following stretch (Avela et al., 2004; Kubo et al., 2001a), a potentiating effect on force has been reported following intense contractions (Baudry & Duchateau, 2007; Chiu et al., 2003; Gilbert & Lees, 2005; Hamada et al. 2003; O'Leary et al., 1997). Therefore, the changes induced by the muscular contractions may influence the effects of a subsequent bout of stretch. Intriguingly, no previous studies have explicitly examined this.

The effects of a series of intermittent maximal voluntary isometric contractions (MVIC) followed by static stretch on concentric and passive joint moment, EMG activity, Achilles tendon stiffness and muscle operating length, were examined in Study 2 (Chapter 4). A significant reduction in concentric joint moment was detected following the MVIC intervention, which was accompanied by, and correlated with ($r = 0.90$; $P < 0.01$), reduced triceps surae EMG amplitude. Thus, the reductions in joint moment were strongly associated with reduced neuromuscular activity. Despite a significant reduction in tendon stiffness, no change in muscle operating length was found as the more compliant tendon deformed to a similar length under the lesser force. Therefore, changes in muscle operating length were clearly not a mechanism underpinning these losses. Also, neuromuscular fatigue was probably not a factor since there was no reduction in force during the isometric contractions. An important finding was that no further change in any measure was detected following a subsequent bout of static stretch (3 min), despite the stretch regime being identical to that used in Study 1 (Chapter 3). For the first time the specific influence of stretch after maximal isometric contractions was examined, with the data showing that the normal stretch-induced force losses did not occur when preceded by the MVICs. The ramifications of these findings are substantive for the design of both experimental methodologies and warm-up routines. Importantly, similar to the findings of Study 1 (Chapter 3), active joint moment and EMG amplitude recovered after 30 min of rest. This suggests that physical tasks requiring high levels of plantarflexor muscle force are unlikely to be compromised at this time. However, the reduced Achilles tendon stiffness persisted, which may have important implications to injury risk for the triceps surae-Achilles muscle-tendon complex given that the greater energy storage capacity of the tendon could reduce rate and magnitude of force transmission to the musculature during eccentric loading of the MTC. It might also 1) positively affect movement economy since energy storage will be greater for a given level of muscle force (according to $E = \frac{1}{2} kx^2$, where k is tendon stiffness and x is tendon elongation), 2) reduce the rate of force development (Wilkie, 1950), and 3) decrease the maximum rate of MTC shortening owing to a decreased restoring force (according to Hooke's Law: $F = -kx$, where F is the restoring force). Thus, the reduction in tendon stiffness following isometric contractions may have important practical implications for the formulation of pre-performance routines. These hypotheses examining the effects on performance and injury risk should be tested in future research.

Reports of both beneficial (Baudry & Duchateau, 2007; Chiu et al., 2003; Gilbert & Lees, 2005; Hamada et al. 2003; O'Leary et al., 1997) and detrimental (Chiu et al., 2003; Gossen & Sale, 2000; Hrysomallis & Kidgell, 2001; Maganaris et al., 2006) effects of intense contractions on force production exist. The reduction in concentric force following the MVICs in Study 2 (Chapter 4) highlights a possible contraction-mode specific response as no significant reduction in isometric force was detected. This suggests that neuromuscular fatigue was not the issue, rather the reduction in concentric force resulted from a mode specific change. Accordingly, whether similar effects on force, EMG and mechanical characteristics of the MTC would be realised from a series of intense concentric contractions, and whether the effects of a

subsequent bout of stretch would also be removed, was examined in the third study. Consistent with the findings from Study 2 (Chapter 4), a significant reduction in concentric joint moment was detected after the performance of maximum voluntary concentric contractions (MVCCs), which was correlated ($r = 0.94$; $P < 0.01$) with a reduction in EMG amplitude. A similar (compared with Study 2 data) reduction in Achilles tendon stiffness was also found but no reduction in muscle operating length was detected. Despite a different contraction mode (concentric) being used compared to Study 2 (isometric), similar reductions in concentric force were detected. Thus, a fatiguing effect of the contractions cannot be ruled out in this case. However, a further reduction in concentric moment occurred after the stretch with no further change in EMG. This further loss in active moment suggests that the concentric contractions did not completely eliminate the effects of stretch. Importantly, while EMG recovered 30 min later, concentric moment remained depressed. Although reduced neuromuscular activity was associated with the initial reduction in joint moment following the concentric intervention, it was clearly not associated with the additional losses incurred post-stretch or the maintenance of these losses 30 min later. What cannot be determined from the present data is why there was a further reduction in force, as no change in EMG or muscle length was detected. Further research is required to assess the mechanisms responsible. An important practical finding from Study 3 (Chapter 5) was that the total losses incurred from the combined concentric contraction + stretch intervention were greater than from stretch alone, however, they were similar to the losses incurred from the combined isometric contractions + stretch intervention (Study 2). Therefore, while greater force losses were evident when either isometric or concentric contractions were performed prior to stretch when compared to stretch in isolation, these losses only remained at 30 min post-stretch when concentric contractions were performed. The implications of these findings are substantive for the design of research studies as the warm-up imposed on participants prior to the stretch seems to strongly influence the stretch-induced loss of force and the temporal effects of stretch. Although it might be expected that a contraction-mode specific warm-up would be optimum, the present data are not in line with this expectation. The implications of this are clearly worth further examination.

Collectively, the data from the three studies indicate that while stretch negatively, but temporarily (<30 min), impacts on force production the inclusion of intense muscular contractions can reduce or remove this effect. While this might appear to be a practically important finding with regard to the design of effective pre-performance routines, the intense muscular contractions themselves were also shown to negatively impact force production. Thus, the total force loss was similar in all three cases (6-10%). Interestingly the contraction mode appears to influence whether subsequent stretch-induced losses are removed and, more importantly, whether they remain 30 min later. Isometric contractions completely removed the subsequent effects of stretch and force recovered 30 min later, however concentric contractions were followed by additional losses of force after the stretch and, more importantly, these losses remained 30 min later. These data indicate that pre-performance routines including intense isometric contractions prior to the implementation of stretch should not negatively influence

concentric force production if an adequate recovery time is allowed prior to performance (~30 min). The data are also suggestive that the use of strong concentric contractions might be problematic if used in conjunction with a stretch regime similar to that used in the present research. Given the negative effects seen with the use of maximal muscle contractions, further research is required to determine whether modifying the duration, intensity and repetition of contractions can remove the detrimental effects on force production whilst also ensuring that subsequent stretching does not incur additional losses in force.

A largely consistent finding was that regardless of the intervention imposed (stretch or muscular contractions), the well-documented losses in force were strongly correlated ($r = 0.60 - 0.94$; $P < 0.01$) with reduced neuromuscular activity (EMG amplitude). These findings clearly emphasise the importance of neuromuscular activity as a mechanism underpinning the changes in force. While strong correlations were detected, the change in neuromuscular activity could not explain all the changes in force, although some of this may be attributable to the variability of the EMG signal during prolonged maximal contractions. Several studies examining post-stretch force losses have reported no significant change in EMG (Cramer et al., 2004; Fowles et al., 2000; Kay & Blazevich, 2008; Nelson et al., 2001a, 2001b, Weir et al., 2005), although reductions in passive joint moment led some of these authors to conclude that reductions in active force might be attributable to an increase in tendon compliance. This would result in there being a longer tendon length but shorter muscle length during contraction, according to the muscle's force-length relationship (Maganaris, 2001, 2003). However, a consistent finding in all three studies was that there was no detectable reduction in muscle operating length despite there being a significant decrease in tendon stiffness after isometric and concentric contractions. Thus, reductions in force were associated with decreases in EMG but not a reduction in muscle operating length.

Novel methods of examining EMG, passive joint moment and GM and Achilles tendon length were used in the present research; the reliability of these methods has been established in this thesis (see Chapter 3). Although initial pilot testing revealed very high correlations between active joint moment and EMG in all three triceps surae muscles ($r = 0.92 - 0.99$; see Chapter 3) the cyclic turnover of motor units (Taylor et al., 2000b) when a maximal contraction is held for a prolonged period (>5 s) may increase the variability of the EMG signal recorded during a ramped isometric plantarflexion (between 70 – 100% MVC). This variability may reduce the strength of the correlation between EMG amplitude changes and changes in active joint moment, and therefore reduce the perceived importance of changes in neuromuscular activity as a mechanism underpinning the force losses. The averaging of EMG amplitudes of the individual muscle components within the triceps surae (TS) (GM, GL, Sol) was used to generate a single EMG amplitude reflective of the TS muscle group. An important and novel finding from this method was that the changes in TS EMG amplitude consistently generated stronger correlations with the changes in joint moment than individual EMG amplitudes. The averaging of the three individual EMG amplitudes reduced the variability of the signals resulting in stronger

correlations with moment losses. This could be an important methodological development for the analysis of EMG during maximal contractions to ensure reliable data are generated.

Another methodological consideration pertains to the measurement of passive joint moment, which is taken to be reflective mostly, but not exclusively, of changes in MTC properties, and is commonly measured to assess the impact of interventions (Kay & Blazevich, 2008; Magnusson et al., 1996c; 1998). The specific joint position at which measurements have been taken has varied from the anatomical position (0°) and 10° dorsiflexion (Muir et al., 1999), to 20° dorsiflexion (Kay & Blazevich, 2008), through to the point of full dorsiflexion (Magnusson et al., 1996c; 1998). However, given the variability in flexibility between individuals, measuring passive moment at a single (arbitrary) ROM may produce invalid and unreliable data. Pilot testing in the present research showed that the ankle joint-moment curve reflected the normal linear stress-strain relationship (see Chapter 3) at dorsiflexed angles above the anatomical position (0°). At joint angles below this inflection point, the passive moment curve did not reflect the normal stress-strain relationship, probably because the MTC tissues were at their slack length or in the toe region of the relationship. This inflection point was not consistent across individuals, which is indicative of their varying joint flexibilities (i.e. ranges of motion). Accordingly, passive joint moment in the present research was examined at a range of joint angles (see Chapter 3) calculated to be a prescribed percentage of the joint range between the inflection point and maximum range of motion. An interesting finding in the present study was that no significant reductions were detected in passive joint moment at 10% or 30% of ROM (closest to the inflection point). This might be due to the reliability of joint moment measurement (measured in the control condition; see Chapter 3) being lower at these joint angles; coefficients of variance increased from 1.9% at 50% of ROM to 5.3% at 10% of ROM. Under these conditions statistical significance may be more difficult to detect. Alternatively, it might also be suggestive of the stretch affecting the parallel elastic component, so changes were only detected when the muscle was stretched beyond its slack length. The measurement of joint moment at several joint angles and the determination of the inflection point, as conducted within the present research, may be important methodological considerations for future research as analysis of passive joint moment at plantarflexed ROMs (i.e. below the inflection point) could produce unreliable data and mask the effects of stretch on the mechanical properties of the MTC tissues.

Several important findings have been reported in the present thesis including: 1) the reduced effect of stretch after maximal isometric or concentric contractions are performed, 2) the strong correlation between force losses and reductions in EMG amplitude, 3) the lack of changes in muscle operating length after stretch or muscle contractions, 4) the prolonged (30 min) reduction in tendon stiffness following muscular contractions, and 5) the new methodological approach for measuring EMG, passive moment and MTC properties. These findings have generated several recommendations for future research. First, the correlation between EMG and force losses was weaker at more plantarflexed angles so further research should determine

whether this effect was muscle-length (joint-angle) dependent or whether the duration of the contraction increased the variability of the EMG signal. Second, although a clear reduction in EMG amplitude was apparent, the location of the impairment in neuromuscular activity (motor cortex, spinal, NMJ) remains unknown, so further research is required to ascertain the location of the impairment; electrical or magnetic stimulation techniques might prove very useful in this regard. Finally, acute reductions in tendon stiffness remained for at least 30 min after the isometric and concentric contraction (plus stretch) interventions, so further research should be conducted to ascertain the influence of this decreased stiffness on movement performance and injury risk.

References

- Abbate, F., Sargeant, A. J., Verdijk, P. W. & De Hann, A. (2000). Effects of High-frequency initial pulses and posttetanic potentiation on power output of skeletal muscle. *Journal of Applied Physiology*, 88, 35-40.
- Agre, J. C. (1985). Hamstring injuries, proposed etiological factors, prevention, and treatment. *Sports Medicine*, 2, 21-33.
- Alexander, R. M. & Bennet-Clark, H. C. (1977). Storage of elastic strain energy in muscle and other tissues. *Nature*, 265, 114-117.
- Alter, M. J. (1996) *Science of Flexibility*. 2nd Ed. Champagne, Ill: Human Kinetics.
- Alkner, B. A, Tesch, P. A. & Berg, H. E. (2000). Quadriceps EMG/force relationship in knee extension and leg press. *Medicine & Science in Sports & Exercise*, 32, 459-463.
- Arampatzis, A., Stafilidis, G., DeMonte, G., Karamanidis, K., Morey-Klapsing, G. & Brüggemann, G. P. (2005). Strain and elongation of the human gastrocnemius tendon and aponeurosis during maximal plantarflexion effort. *Journal of Biomechanics*, 38, 833-841.
- Armstrong, R. B., Duan, C., Delp, M. D, Hayes, D. A., Glenn, G. M. & Allen, G. D. (1993). Elevations in rat soleus muscle (Ca^{2+}) with passive stretch. *Journal of Applied Physiology*, 74, 2990-2997.
- Avela, J. & Komi, P. V. (1998). Reduced stretch reflex sensitivity and muscle stiffness after long-lasting stretch-shortening cycle exercise in humans. *European Journal of Applied Physiology*, 78, 403-410.
- Avela J., Kyröläinen H. & Komi P. V. (1999). Altered reflex sensitivity due to repeated and prolonged passive muscle stretching. *Journal of Applied Physiology*, 86, (4), 1283-1291.
- Avela, J., Finni, T., Liikavainio, T., Niemela, E. & Komi, P. V. (2004). Neural and mechanical responses of the triceps surae muscle group after 1 h of repeated fast passive stretches. *Journal of Applied Physiology*, 96, 2325-2332.
- Baudry, S. & Duchateau, J. (2007). Postactivation potentiation in a human muscle: effect on rate of torque development of titanic and voluntary isometric contractions. *Journal of Applied Physiology*, 102, 1394-1401.

- Behm, D. G., Button, D. C. & Butt, J. C. (2001). Factors affecting force loss with prolonged stretching. *Canadian Journal of Applied Physiology*, 26 (3), 261-272.
- Behm, D. G., Bambury, A., Cahill, F. & Power, K. (2004). Effect of acute static stretching on force, balance, reaction time, and movement time. *Medicine & Science in Sports & Exercise*, 36, 1397-1402.
- Belli, A. & Bosco, C. (1992) Influence on stretch shortening cycle on mechanical behaviour of triceps surae during hopping. *Acta Physiologica Scandinavica*, 144, 401-408.
- Bigland, B. & Lippold, O.C.J. (1954). The relation between force, velocity and integrated electrical activity in human muscles. *Journal of Physiology*, 123, 214-224.
- Bilodeau, M., Schindler-Ivens, S., Williams, D. M., Chandran, R. & Sharma, S. S. (2003). EMG frequency content changes with increasing force during fatigue in the quadriceps femoris muscle of men and women. *Journal of Electromyography and Kinesiology*, 13, 83-92.
- Bishop, D. (2003). Performance changes following active warm-up and how to structure the warm-up. *Sports Medicine*, 33 (7), 483-498.
- Bloch, R. J., & Gonzalez-Serratos, H. (2003). Lateral force transmission across costameres in skeletal muscle. *Exercise & Sport Science Reviews*, 31, 73-78.
- Bobbert, M. F., Huijing, P. A. & Ingen Shenau, G. J. (1986). A model of the human triceps surae muscle-tendon complex applied to jumping. *Journal of Biomechanics*, 19, 887-898.
- Bojsen-Møller, J., Magnusson, S. P., Rasmussen, L. R., Kjaer, M. & Aagaard, P. (2005). Muscle performance during maximal isometric and dynamic contractions is influenced by the stiffness of the tendinous structures. *Journal of Applied Physiology*, 99, 986-994.
- Bradley, P. S., Olsen, P. D., & Portas, M. D. (2007). The effect of static, ballistic, and proprioceptive neuromuscular facilitation stretching on vertical jump performance. *Journal of Strength & Conditioning Research*, 21, 223-226.
- Brandenburg, J. P. (2006). Duration of stretch does not influence the degree of force loss following static stretching. *Journal of Sports Medicine and Physical Fitness*, 46 (4), 526-534.
- Bruton, J. D., Lannergren, J. & Westerblad, H. (1996) Effects of repetitive tetanic stimulation at long intervals on excitation-coupling in frog skeletal muscle. *Journal of Physiology*, 495, 15-22.

- Campbell, K. P., & Stull, J. T. (2003). Skeletal muscle basement membrane-sarcolemma-cytoskeleton interaction mini review series. *Journal of Biological Chemistry*, 278, 12599-12600.
- Chiu, L. Z., Fry, A. C., Weiss, L. W., Schilling, B. K., Brown, L. E. & Smith, S. L. (2003). Postactivation potentiation response in athletic and recreationally trained individuals. *Journal of Strength & Conditioning Research*, 17, 671-677.
- Cifrek, M., Medved, V., Tonković, S. & Ostojić, S. (2009). Surface EMG based muscle fatigue evaluation in biomechanics. *Clinical Biomechanics*, 24, 327-340.
- Cornwell, A., Nelson, A. G. & Sidaway, B. (2002). Acute effects of stretching on the neuromechanical properties of the triceps surae muscle complex. *European Journal of Applied Physiology*, 86 (5), 428-434.
- Craib, M. W., Mitchell, V. A., Fields, K. B., Cooper, T. R., Hopewell, R. & Morgan, D. W. (1996). The association between flexibility and running economy in sub-elite male distance runners. *Medicine & Science in Sports & Exercise*, 28, 737-743.
- Cramer, J. T., Housh, T. J., Johnson, G. O., Miller, J. M., Coburn, J. W. & Beck, T. W. (2004). Acute effects of static stretching on peak torque in women. *Journal of Strength and Conditioning Research*, 18 (2), 236-241.
- Cramer, J. T., Housh, T. J., Weir, J. P., Johnson, G. O., Coburn, J. W. & Beck, T. W. (2005). The acute effects of static stretching on peak torque, mean power output, electromyography, and mechanomyography. *European Journal of Applied Physiology*, 93, 530-539.
- Cramer, J. T., Housh, T. J., Coburn, J. W., Beck, T.W. & Johnson, G. O. (2006). Acute effects of static stretching on maximal eccentric torque production in women. *Journal of Strength & Conditioning Research*, 20, 354-358.
- Cramer, J. T., Beck, T. W., Housh, T. J., Massey, L. L., Marek, S. M., Danglemeier, S., Purkayastha, S., Culbertson, J. Y., Fitz, K. A. & Egan, A. D. (2007). Acute effects of static stretching on characteristics of the isokinetic angle-torque relationship, surface electromyography, and mechanomyography. *Journal of Sports Sciences*, 25 (6), 687-698.
- Cresswell, A. G., Löscher, W. N. & Thorstensson, A. (1995). Influence of gastrocnemius muscle length on triceps surae torque development and electromyographic activity in man. *Experimental Brain Research*, 105, 283-290.

- Czerniecki, J. M., Gitter, A. & Monroe, C. (1991). Joint moment and muscle power output characteristics of below knee amputees during running: the influence of energy storing prosthetic feet. *Journal of Biomechanics*, 24, 63-75.
- DeLuca, C. J. (1997). The use of surface electromyography in biomechanics. *Journal of Applied Biomechanics*, 13, 135-163.
- Edman, K. A. P. & Josephson, R. K. (2007). Determinants of force rise time during isometric contraction of frog muscle fibres. *Journal of Physiology*, 580 (3), 1007-1019.
- Egan, A. D., Cramer, J. T., Massey, L. L. & Marek, S. M. (2006). Acute effects of static stretching on peak torque and mean power output in national collegiate athletic association division I women's basketball players. *Journal of Strength & Conditioning Research*, 20, 778-782.
- Enoka, R. M. (1994). *Neuromechanical Basis of Kinesiology*, 2nd Ed. Champagne, Ill: Human Kinetics.
- Ervasti, J. M. (2003). Costameres: The Achilles heel of herculean muscle. *Journal of Biological Chemistry*, 278, 13591-13594.
- Evarts, E. V. (1979). Brain mechanisms of movement. *Scientific American*, 241, 164-179.
- Evetovich, T. K., Nauman, N. J., Conley, D. S. & Todd, J. B. (2003). Effect of stretching of the biceps brachii on torque, electromyography, and mechanomyography during concentric isokinetic muscle actions. *Journal of Strength & Conditioning Research*, 17, 484-488.
- Field, A. (2009). *Discovering Statistics using SPSS*. 3rd Ed. London: Sage.
- Fowles, J. R., Sale, D. G. & MacDougall, J. D. (2000). Reduced strength after passive stretch of the human plantarflexors. *Journal of Applied Physiology*, 90, 1179-1188.
- Franchi, M., Fini, M., Quaranta, M., De Pasquale, V., Raspanti, M., Giavaresi, G., Ottani, V., & Ruggeri, A. (2007). Crimp morphology in relaxed and stretched rat Achilles tendon. *Journal of Anatomy*, 210, 1-7.
- Fukanaga, T., Kawakami, Y., Kuno, S., Funato., K. & Fukashiro, S. (1997). Muscle architecture and function in humans. *Journal of Biomechanics*, 30, 457-463.
- Gajdosik, R. L. (2001). Passive extensibility of skeletal muscle: Review of the literature with clinical implications. *Clinical Biomechanics*, 16, 87-101.

- Gandevia, S. C. (1992). Some central and peripheral factors affecting human motoneuronal output in neuromuscular fatigue. *Sports Medicine*, 13, 93-98.
- Giddings, V. L., Beaupre, G. S., Whalen, R. T. & Carter, D. R. (2000) Calcaneal loading during walking and running. *Medicine & Science in Sports & Exercise*, 32, 627-634.
- Gilbert, G. & Lees, A. (2005). Changes in the force development characteristics of muscle following repeated maximum force and power exercise. *Ergonomics*, 48, 1576-1584.
- Gleim, G. W., Stachenfeld, N. S. & Nicholas, J. A. (1990). The influence of flexibility on walking and jogging. *Journal of Orthopaedic Research*, 8, 814-823.
- Gleim, G. W. & McHugh, M. P. (1997). Flexibility and its effects on sports injury and performance. *Sports Medicine*, 24, 289-299.
- Gossen, E. R. & Sale, D. G. (2000). Effect of postactivation potentiation on dynamic knee extension performance. *European Journal of Applied Physiology*, 83, 524-30.
- Grange, R. W., Vanderboom, R. & Houston, M. E. (1993). Physiological significance of myosin phosphorylation in skeletal muscle. *Canadian Journal of Applied Physiology*, 18, 229-242.
- Grosset, J. F., Piscione, J., Lambertz, D. & Pérot, C. (2009). Paired changes in electromechanical delay and musculo-tendinous stiffness after endurance or plyometric training. *European Journal of Applied Physiology*, 105, 131–139.
- Hamada, T., Sale, D. G., MacDougall, J. D. & Tarnopolsky, M. A. (2003). Interaction of fibre type, potentiation and fatigue in human knee extensor muscles. *Acta Physiologica Scandinavica*, 178, 165-173.
- Herbert, R. D. & Crosbie, J. (1997). Rest length and compliance of non-immobilised rabbit soleus muscle and tendon. *European Journal of Applied Physiology*, 76, 472-479.
- Herbert, R. D., Moseley, A. M., Butler, J. E. & Gandevia, S. C. (2002). Change in length of relaxed muscle fascicles and tendons with knee and ankle movement in humans. *Journal of Physiology*, 539, 637-645.
- Hess, G. P. Cappiello, W. I. Poole, R. M. & Hunter, S. C. (1989). Prevention and treatment of overuse tendon injuries. *Sports Medicine*, 8, 371-384.

- Hrysomallis, C. & Kidgell, D. (2001). Effect of heavy dynamic resistive exercise on acute upper-body power. *Journal of Strength & Conditioning Research*, 15, 426-30.
- Huxley, H. E. (1967). Recent X-ray Diffraction and Electron Microscope Studies of Striated Muscle. *The Journal of General Physiology*, 50 71-83.
- Hwang, I. S. & Abraham, L. D. (2001). Quantitative EMG analysis to investigate synergistic coactivation of ankle and knee muscles during isokinetic ankle movement. Part 1: time amplitude analysis. *Journal of Electromyography & Kinesiology*, 11, 396-410.
- Iazzio, P. A. (1990). Twitch relaxation of the cat soleus muscle at different lengths and temperatures. *Muscle & Nerve*, 13, 1105-1112.
- Kawakami, Y., Ichinose, Y. & Fukunaga, T. (1998). Architectural and functional features of human triceps surae muscles during contraction. *Journal of Applied Physiology*, 85 (2), 398-404.
- Kay, A. D. & Blazevich, A. J. (2008). Reductions in active plantarflexor moment are significantly correlated with static stretch duration. *European Journal of Sport Science*, 8, 41-46.
- Kinugasa, R., Kawakami, Y. & Fukunaga, T. (2004). Muscle activation and its distribution within the human triceps surae muscles. *Journal of Applied Physiology*, 99, 1149-1156.
- Kirkendall, D. T., & Garrett, W. E. (1997). Function and biomechanics of tendons. *Scandinavian Journal of Medicine & Science in Sports*, 7, 62-66.
- Knudson, D. & Noffal, G. (2005). Time course of stretch-induced isometric strength deficits. *European Journal of Applied Physiology*, 94, 348-351.
- Kokkonen, J., Nelson, A. G. & Cornwell, A. (1998). Acute muscle stretching inhibits maximal strength performance. *Research Quarterly for Sport and Exercise*, 69, 411-415.
- Kubo, K., Akima, H., Kouzaki, M., Ito, M., Kawakami, Y., Kanehisa, H & Fukunaga, T. (2000). Changes in the elastic properties of tendon structures following 20 days bed-rest in humans, *European Journal of Applied Physiology*, 83, 463-468.
- Kubo, K., Kanehisa, H., Kawakami, Y. & Fukunaga, T. (2001a). Influence of static stretching on viscoelastic properties of human tendon structures in vivo. *Journal of Applied Physiology*, 90, 520-527.

- Kubo, K., Kanehisa, H., Kawakami, Y. & Fukunaga, T. (2001b). Influences of repetitive muscle contractions with different modes on tendon elasticity in vivo. *Journal of Applied Physiology*, 91, 277-282.
- Lakie, M., Walsh, E.G. & Wright, G. W. (1984). Resonance at the wrist demonstrated by the use of a torque motor: an instrumental analysis of muscle tone in man. *Journal of Physiology*, 353, 265-285.
- Lamb, G. D., Junankar, P. R. and Stephenson, D. G. (1995) Raised intracellular (Ca^{2+}) abolishes excitation-contraction coupling in skeletal muscle fibres of rat and toad. *Journal of Applied Physiology*, 489, 349-362.
- Lippold, O. C. J. (1952). The relation between integrated action potentials in human muscle and its isometric tension. *Journal of Physiology*, 117, 492-499.
- MacIntosh, B. R. & Willis, J. C. (2000). Force-frequency relationship and potentiation in mammalian skeletal muscle. *Journal of Applied Physiology*, 88, 2088-2096.
- Maganaris, C. N. (2001). Force-length characteristics of in vivo human skeletal muscle. *Acta Physiologica Scandinavica*, 172, 279-285.
- Maganaris, C. N. (2003). Force-length characteristics of the in vivo human gastrocnemius muscle. *Clinical Anatomy*, 16, 215-223.
- Maganaris, C. N., Baltzopoulos, V., & Sargeant, A. J. (2006). Human calf muscle responses during repeated isometric plantarflexions. *Journal of Biomechanics*, 39, 1249-1255.
- Magnusson, S. P., Simonsen, E. B., Aagaard, P., Dyhre-Poulsen, P., McHugh, M. P., & Kjaer, M. (1996a). Mechanical and physiological responses to stretching with and without preisometric contraction in human skeletal muscle. *Archives of Physical Medicine & Rehabilitation*, 77, 373-378.
- Magnusson, S. P., Simonsen, E. B., Dyhre-Poulsen, P., Aagaard, P., Mohr, T., & Kjaer, M. (1996b). Viscoelastic stress relaxation during static stretch in human skeletal muscle in the absence of EMG activity. *Scandinavian Journal of Medicine & Science in Sports*, 6, 323-328.
- Magnusson, S. P., Simonsen, E. B., Aagaard, P. & Kjaer, M. (1996c). Biomechanical responses to repeated stretches in human hamstring muscle in vivo. *American Journal of Sports Medicine*, 24, 622-628.

- Magnusson, S. P., Aagaard, P., Simonsen, E. B., & Bojsen-Møller, F. (1998). A biomechanical evaluation of cyclic and static stretch in human skeletal muscle. *International Journal of Sports Medicine*, 19, 310-316.
- Magnusson, S. P., Aagaard, P. & Nielson, J. J. (2000). Passive energy return after repeated stretches of the hamstring muscle-tendon unit. *Medicine & Science in Sports & Exercise*, 32 (6), 1160-1164.
- Maisetti, O., Sastre, J., Lecompte, J. & Portero, P. (2007). Differential effects of an acute bout of passive stretching on maximal voluntary torque and the rate of torque development of the calf muscle-tendon unit. *Isokinetics in Exercise Science*, 15, 11-17.
- McArdle, W. D., Katch, F. I. & Katch, V. L. (2001). *Exercise Physiology: Energy, Nutrition & Performance*. 5th Ed. Baltimore, MD: Lippincott, Williams & Wilkins.
- McBride, J. M., Deane, R., & Mimphuis, S. (2007). Effect of stretching in agonist-antagonist muscle activity and muscle force output during single and multiple joint isometric contractions. *Scandinavian Journal of Medicine & Science in Sports*, 17, 54-60.
- McComas, A. J. (1996). *Skeletal muscle: Form and function*. Champagne, Ill: Human Kinetics.
- McHugh, M. & Nesse, M. (2008). Effects of stretch on strength loss and pain after eccentric exercise. *Medicine & Science in Sports & Exercise*, 40, 566-573.
- McClay, I. & Manal, K. (1999) Three-dimensional kinetic analysis of running: significance of secondary planes of motion. *Medicine & Science in Sports & Exercise*, 31, 1629-1637.
- McMahon, T. A., Valiant, G. & Frederick, E. C. (1987) Groucho running. *Journal of Applied Physiology*, 62, 2326-2337.
- McNair, P. J. & Stanley, S. N. (1996). Effect of passive stretching and jogging on the series elastic muscle stiffness and range of motion of the ankle joint. *British Journal of Sports Medicine*, 30, 313-318.
- McNair, P. J., Dombroski, E. W., Hewson, D. J. & Stanley, S. N. (2001). Stretching at the ankle joint: viscoelastic responses to holds and continuous passive motion. *Medicine & Science in Sports & Exercise*, 33, 354-358.
- McNair, P. J. & Portero, P. (2005). Using Isokinetic dynamometers for measurement associated with tissue extensibility. *Isokinetics & Exercise Science*, 13, 53-56.

- Meissner, G. & Lu, X. (1995). Dihydropyridine receptor-ryanodine receptor interactions in skeletal muscle excitation-contraction coupling. *Bioscience Reports*, 15, 399-408.
- Metzger, J. M., Greaser, M. L. & Moss, R. L. (1989). Variations in cross-bridge attachment rate and tension with phosphorylation of myosin in mammalian skinned muscle fibres. Implications for twitch potentiation in intact muscle. *Journal of General Physiology*, 93, 855-883.
- Morgan, D. L., Prochazka, A. & Proske, U. (1984). The after-effects of stretch and fusimotor stimulation on the responses of primary endings of cat muscle spindles. *Journal of Physiology*, 356, 465-477.
- Morimoto, S. & Masuda, M. (1984). Dependence of conduction velocity on spike interval during voluntary muscular contraction in human motor units. *European Journal of Applied Physiology & Occupational Physiology*, 53, 191-195.
- Morse, C. I., Degens, H., Seynnes, O. R., Maganaris, C. N. & Jones, A. J. (2008). The acute effect of stretching on the passive stiffness of the human gastrocnemius muscle tendon unit. *Journal of Physiology*, 586, 97-106.
- Muir, I. W., Chesworth, B. M. & Vandervoort, A. A. (1999). Effect of a static calf-stretching exercise on the resistive torque during passive ankle dorsiflexion in healthy subjects. *Journal of Orthopaedic & Sports Physical Therapy*, 29, 106-115.
- Muramatsu, T., Muraoka, T., Takeshita, D., Kawakami, Y., Hirano, Y. & Fukunaga, T. (2001). Mechanical properties of tendon and aponeurosis of human gastrocnemius muscle in vivo. *Journal of Applied Physiology*, 90, 1671-1678.
- Murray, M. P., Guten, G. N., Baldwin, J. M. & Gardener, G. M. (1976). A comparison of plantar flexion torque with and without the triceps surae. *Acta Orthopaedica Scandinavica*, 47, 122-124.
- Nelson, A. G., Allen, J. D., Cornwell, A. & Kokkonen, J. (2001a). Inhibition of maximal voluntary isometric torque production by acute stretching is joint-angle specific. *Research Quarterly for Exercise and Sport*, 72, 68-70.
- Nelson, A. G., Guillory, I. K., Cornwell, A. & Kokkonen, J. (2001b). Inhibition of maximal voluntary isometric torque production by acute stretching is velocity specific. *Journal of Strength & Conditioning Research*, 15, 241-246.
- Nistal, M., Paniagua, R., & Morales, C. (1977). Irregular patterns of actin and myosin filaments in human skeletal muscle. *Cell & Tissue Research*, 181, 403-407.

- Nubar, Y. (1962). Stress-strain relationship in skeletal muscle. *Annals of the New York Academy of Sciences*, 93, 859-76
- O'Brien, M. (1997). Structure and metabolism of tendons. *Scandinavian Journal of Medicine & Science in Sports*, 7, 55-61.
- Oksa, J., Rintamäki, H., Mäkinen, T., Martikkala, V. & Rusko, H. (1996). EMG-activity and muscular performance of lower leg during stretch-shortening cycle after cooling. *Acta Physiologica Scandinavica*, 157, 71-78.
- Ogura, Y., Miyahara, Y., Naito, H., Katamoto, S. & Aoki, J. (2007). Duration of static stretching influences muscle force production in hamstring muscles. *Journal of Strength & Conditioning Research*, 21, 788-792.
- O'Leary, D.D., Hope, K. & Sale, D. G. (1997). Posttetanic potentiation of human dorsi flexors. *Journal of Applied Physiology*, 83, 2131-2138.
- Orchard, J., Marsden, J., Lord, S. & Garlick, D. (1997). Preseason hamstring muscle weakness associated with hamstring muscle injury in Australian footballers. *American Journal of Sports Medicine*, 25, 81-85.
- Palmer, B. M. & Moore, R. L. (1989). Myosin light chain phosphorylation and tension potentiation in mouse skeletal muscle. *American Journal of Physiology*, 257, 1012-1019.
- Proske, U., Morgan, D. L. & Gregory, J. E. (1993). Thixotropy in skeletal muscle and in muscle spindles: A review. *Progressive Neurobiology*, 41, 705-721.
- Proske, U. & Morgan, D. L. (1999). Do cross-bridges contribute to the tension during stretch of passive muscle? *Journal of Muscle Research & Cell Motility*, 20, 433-442.
- Purslow, P. P. (1989). Strain-induced reorientation of an intramuscular connective tissue network: Implications for passive stretch. *Journal of Biomechanics*, 22, 21-31.
- Ranatunga, K. W. (2001). Sarcomeric visco-elasticity of chemically skinned skeletal muscle fibres of the rabbit at rest. *Journal of Muscle Research and Cell Motility*, 22, 399-414.
- Rassier, D. E., MacIntosh, B. R., & Herzog, W. (1999). Length dependence of active force production in skeletal muscle. *Journal of Applied Physiology*, 86, 1445-1457.
- Rosenbaum, D. & Hennig, E. M. (1995). The influence of stretching and warm-up exercises on Achilles tendon reflex activity. *Journal of Sports Sciences*, 13, 481-490.

- Ryan, E. D., Beck, T. W., Herda, T. J., Hull, H. R., Hartman, M. J., Stout, J. R. & Cramer, J. T. (2008). Do practical durations of stretching alter muscle strength? A dose-response study. *Medicine & Science in Sports & Exercise*, 40: 1529-1537.
- Shier, D., Butler, J. & Lewis, R. (2002). *Human Anatomy & Physiology, 9th Ed.* New York, NY: McGraw-Hill.
- Siatras, T. A., Mittas, V. P., Mameletzi, D. N. & Vamvakoudis, E. A. (2008). The duration of the inhibitory effects with static stretching on quadriceps peak torque production. *Journal of Strength & Conditioning Research*, 22, 40-46.
- Taylor, J. L., Allen, G.M., Butler, J. E. & Gandevia, S. C. (2000a). Supraspinal fatigue during intermittent maximal voluntary contractions of the human elbow flexors. *Journal of Applied Physiology*, 89, 305-313.
- Taylor, J. L., Allen, G. M., Butler, J. E. & Gandevia, S. C. (2000b). Changes in muscle afferents, motoneurons and motor drive during muscle fatigue. *European Journal of Applied Physiology*, 83, 106-115.
- Thacker, S. B., Gilchrist, J., Stroup, D. F. & Kimsey, C. D. (2004). The impact of stretching on sports injury risk: A systematic review of the literature. *Medicine & Science in Sports & Exercise*, 36 (3), 371-378.
- Vandervoort, A. A., Quinlan, J. & McComas, A. J. (1983). Twitch potentiation after voluntary contractions. *Experimental Neurology*, 81, 141-152.
- Viale, F., Nana-Ibrahim, S. & Martin, R. J. F. (2007). Effect of active recovery on acute strength deficits induced by passive stretching. *Journal of Strength & Conditioning Research*, 21, 1233-1237.
- Vogel, K. G. (2003). Tendon structure and response to changing mechanical load. *Journal of Musculoskeletal & Neuronal Interactions*, 3, 323-325.
- Voigt, M., Bojsen-Møller, F., Simonsen, E. B. & Dyhre-poulsen, P. (1995). The influence of tendon Young's modulus, dimensions and instantaneous moment arms on the efficiency of human movement. *Journal of Biomechanics*, 28, 281-291.
- Wang, K., McCarter, R., Wright, J., Beverly, J., & Ramirez-Mitchell, R. (1993). Viscoelasticity of the sarcomere matrix of skeletal muscles; The titin-myosin composite filament is a dual-stage molecular spring. *Biophysics Journal*, 64, 1161-1177.

- Weir, D. E., Tingley, E., Elder, J. & Geoffrey, C. B. (2005). Acute passive stretching alters the mechanical properties of human plantar flexors and the optimal angle for maximal voluntary contraction. *European Journal of Applied Physiology*, 93 (5-6), 614-623.
- Weldon, S. M. & Hill, R. H. (2003). The efficacy of stretching for prevention of exercise-related injury: A systematic review of the literature. *Manual Therapy*, 8 (3), 141-150.
- Wilkie, D. R. (1950). The relation between force and velocity in human muscle. *Journal of Physiology*, 110, 249-280.
- Wilmore, J. H. & Costill, D. L. (1999). *Physiology of Sport & Exercise*. 2nd Ed. Champagne, Ill: Human Kinetics.
- Wilson, G. J., Murphy, A. J. & Pryor, J. F. (1994). Musculotendinous stiffness: its relationship to eccentric, isometric, and concentric performance. *Journal of Applied Physiology*, 76 (6), 2714-2719.
- Winter, D. A. (1983). Moments of force and mechanical power in jogging. *Journal of Biomechanics*, 16, 91-97.
- Witvrouw, E., Mahieu, N., Danneels, L. & McNair, P. (2004). Stretching and injury prevention: An obscure relationship. *Sports Medicine*, 34 (7), 443-449.
- Woods, K., Bishop, P. & Jones, E. (2007). Warm-up and stretching in the prevention of muscular injury. *Sports Medicine*, 37 (12), 1089-1099.
- Yamaguchi, T., Ishii, K., Yamaga, M., & Yasuda, K. (2006). Acute effect of static stretching on power output during concentric dynamic constant external resistance leg extension. *Journal of Strength & Conditioning Research*, 20, 804-810.
- Yeung, E. W, Balnave, C. D., Ballard, H. J., Bourreau, P. P. and Allen, D. G. (2002) Development of t-tubular vacuoles in eccentrically damaged mouse muscle fibres. *Journal of Physiology*, 540 (2), 581-592.
- Young, W., Elias, G. & Power, J. (2006). Effects of static stretching volume and intensity on plantar flexor explosive force production and range of motion. *Journal of Sports Medicine & Physical Fitness*, 46, 43-411.

Appendix 1
Power Analyses

Prior to the calculation of the effect size, pooled standard deviation was calculated, as depicted in the following equation depicted below.

$$\text{Pooled standard deviation} = \sqrt{\left(\frac{s_1^2 (n_1 - 1) + s_2^2 (n_2 - 1)}{n_1 + n_2 - 2} \right)}$$

s = standard deviation

n = number of individuals in the sample

Once pooled standard deviation has been calculated, effect size was determined using the equation below and power calculations were then used to determine the appropriate sample size required to reach statistical power.

$$\text{Effect size} = \frac{(m_1 - m_2)}{\text{PSD}}$$

m = mean

PSD = pooled standard deviation

An example of this calculation is presented below for maximal joint moment taken from data presented within Avela & Komi (1998).

$$\text{Pooled standard deviation} = \sqrt{\left(\frac{130^2 (9 - 1) + 187^2 (9 - 1)}{9 + 9 - 2} \right)} \quad \text{PSD} = 161$$

$$\text{Effect size} = \frac{1108 - 953}{161} = 0.91$$

SAMPLE SIZE = 13

Maximal Joint moment

Behm et al., (2001)

$$\text{Pooled standard deviation} = \sqrt{\left(\frac{121^2 (12 - 1) + 121^2 (12 - 1)}{12 + 12 - 2} \right)} \quad \text{PSD} = 121$$

$$\text{Effect size} = \frac{775 - 670}{121} = 0.87$$

SAMPLE SIZE = 16

Avela & Komi (1998)

$$\text{Pooled standard deviation} = \sqrt{\left(\frac{130^2 (9 - 1) + 187^2 (9 - 1)}{9 + 9 - 2} \right)} \quad \text{PSD} = 161$$

$$\text{Effect size} = \frac{1108 - 953}{161} = 0.91$$

SAMPLE SIZE = 13

Tendon Stiffness

Kubo et al. (2001a)

$$\text{Pooled standard deviation} = \sqrt{\left(\frac{21.3^2 (8 - 1) + 33.4^2 (8 - 1)}{8 + 8 - 2} \right)} \quad \text{PSD} = 28$$

$$\text{Effect size} = \frac{106.2 - 65.7}{28} = 1.38$$

SAMPLE SIZE = 6

Morse et al. (2008)

$$\text{Pooled standard deviation} = \sqrt{\left(\frac{3.6^2 (8 - 1) + 2^2 (8 - 1)}{8 + 8 - 2} \right)} \quad \text{PSD} = 2.91$$

$$\text{Effect size} = \frac{16 - 10.2}{2.91} = 1.99$$

SAMPLE SIZE = 3

Passive Joint Moment

Kay & Blazevich (2008)

$$\text{Pooled standard deviation} = \sqrt{\left(\frac{4.9^2 (7 - 1) + 4.8^2 (7 - 1)}{7 + 7 - 2} \right)} \quad \text{PSD} = 4.85$$

$$\text{Effect size} = \frac{21.3 - 17.0}{4.85} = 0.89$$

SAMPLE SIZE = 16

Weir et al., (2005)

$$\text{Pooled standard deviation} = \sqrt{\left(\frac{5.5^2 (15 - 1) + 5^2 (15 - 1)}{15 + 15 - 2} \right)} \quad \text{PSD} = 5.26$$

$$\text{Effect size} = \frac{37 - 30}{5.26} = 1.33$$

SAMPLE SIZE = 7

EMG

Cornwell et al. (2002)

$$\text{Pooled standard deviation} = \sqrt{\left(\frac{75^2 (10 - 1) + 55^2 (10 - 1)}{10 + 10 - 2} \right)} \quad \text{PSD} = 65.76$$

$$\text{Effect size} = \frac{650 - 580}{65.76} = 1.06$$

SAMPLE SIZE = 11

Behm et al., (2001)

$$\text{Pooled standard deviation} = \sqrt{\left(\frac{35^2 (12 - 1) + 25^2 (12 - 1)}{12 + 12 - 2} \right)} \quad \text{PSD} = 30.41$$

$$\text{Effect size} = \frac{450 - 380}{30.41} = 2.3$$

SAMPLE SIZE = 3

Appendix 2

SCHOOL OF HEALTH RESEARCH ETHICS FORM

1. Project title: Impact of concentric contractions and static stretch on mechanical and neural factors of force production of the triceps surae muscle tendon complex

2. Course of study: PhD

3. Student number

Or if staff, name: Anthony David Kay

I have read and agree to adhere to the School of Health guidelines for conducting ethical research

4. Supervisors' names:

5. Use of human participants: Tick one of the following:

I am using human participants.

I am using archival data where individuals are identifiable

I am **not** using human participants or data where individuals are identifiable and therefore do not need to complete the remainder of this form.

6. Participants: Tick the box which most accurately describes your sample:

Children under 16 years

16-18 year olds

Adults over 65 years old

NHS Patients

Social Care Clients

Health or Social Care Professionals

Members of the public (general)

Members of the public (specific such as professional athletes, teachers, – describe here:)

Members of vulnerable groups (frail elderly, disabled athletes, recently bereaved, members of support groups – describe here: University of Northampton students aged between 18-30 years old will be used.

Other. If other, describe your sample here:

7. Issues for concern: Tick below any issue that relates to this research.

Involves the use of human organs

Will be carried out on NHS or Social Services site

Will be conducted using NHS equipment

Involves invasive techniques (e.g. Taking of blood)

Involves participants undertaking tasks they would not normally undertake

Involves any activity that might be described as an 'invasion of privacy'

Involves deception

- Involves a topic that would be considered 'sensitive'
- Involves the collection of data that is not anonymised (contains identifying information such as name and address)
- Requires participants to have a certain level of fitness.
- Requires participants to be screened (e.g., a medical questionnaire) before acceptance into study
- Other. If other, describe here:

8. Methodology: Tick the appropriate box. Full details of what you will do and where it will happen, should be provided in the accompanying Proposal.

- Questionnaires**
- Interviews**
- Experiments**
- Observations**
- Archival**
- Other.** If other, state here:

9. Recruitment Process. Tick the process that best describes how you plan to recruit participants. Full details of how you will recruit and where it will happen, should be provided in the accompanying Proposal.

- Via poster in a public place such as a library or community centre
- 'Packs' will be provided to named person in an organisation/group to be distributed on my behalf
- Asking personal contacts to pass my information packs to their contacts
- Will be asking friends/family
- Cold calling
- Other. If other, state here:

10. Recruitment material. Tick all the recruitment material you will be using. You **must** use the School of Health templates to produce those. In addition, they **must not** be used until seen and approved by your supervisor.

- Recruitment poster
- Recruitment letter to named person in an organisation/group who will be distributing 'Packs' on your behalf
- Recruitment letter to potential participants
- Participant Information Sheet
- Consent form
- NHS ethics application form
- Other. If other, state here:

11. Risk assessment: Some projects will require risk assessment for participants and/or researchers. In other words, there is a possibility that participants and/or researchers will get hurt collecting data. If so, a risk assessment must be conducted. Tick the appropriate box below concerning your need for risk assessment.

- There is **no** risk of injury to participants and/or researchers, so **no** risk assessment will be conducted.
- There is a potential of injury to participants and/or researchers, so risk assessment has been (or will be) conducted.

Part B To be completed by staff:

Comments:

Date considered by Ethics Advisory Group

Proposal to be returned to Ethics Advisory Group Yes [] No []

Signed on behalf of Ethics Advisory Group

Tick which of the following needs to be developed. **Supervisor to sign off once satisfied**

	Is needed	Final copy seen and approved by supervisor
Recruitment poster	√	√
Recruitment letter to individuals		
Recruitment letter to organisation		
Participant Information Sheet	√	√
Consent form	√	√
NHS ethical application		
Other:		

Consent Form

For Participating in the Study of:

**IMPACT OF CONCENTRIC CONTRACTIONS AND STATIC STRETCH ON MECHANICAL
AND NEURAL FACTORS OF FORCE PRODUCTION OF THE TRICEPS SURAE MUSCLE
TENDON COMPLEX**

(Details of project can be found in attached letter and information sheet)

Please tick the boxes

I have read the study information sheet and understand what is involved.

I understand that the information I disclose will remain confidential and that my data will be destroyed or returned to me after being collated.

I understand that I can withdraw my participation at any time without giving a reason and without any adverse affects to my studies.

I am willing to participate in this project.

Signed: Date:

PARTICIPANT INFORMATION SHEET

About The Researcher:

My name is Tony Kay; I am a Senior Lecturer in Sport & Exercise Biomechanics in the Division of Sport, Exercise & Life Science within the School of Health, The University of Northampton. As part of my responsibilities I am carrying out research towards my PhD. Dr. Anthony Blazeovich at the Brunel University is supervising this study.

Study Title:

Impact of concentric preconditioning contractions and static stretch on mechanical and neural factors of force production of the triceps surae muscle tendon complex

Aim of Study:

This study will look at:

- Impact of pre-conditioning the muscle-tendon complex
- Impact of the above to force production mechanical properties and the ability to contract a muscle-tendon complex
- Subsequent effects of stretch

What the study involves:

After warm-up, you will be placed in a seated position on a strength testing machine (isokinetic dynamometer) with the knee in full extension (180°) and the ankle placed in neutral position (right angles to the lower leg; 0°). The dynamometer will then move you passively through your full range of motion about the ankle joint after which you will perform a series of maximal downward pushes of your foot through your full range of motion at a speed of 5 degrees per second. Muscle activity (measured by passive electrodes stuck onto your skin), muscle force and tendon lengthening (measured by ultrasound imaging) will be recorded. You will then perform three 60 s static stretches of the calf muscles, two minutes later, a second maximal muscle contraction will be performed, and a third 30 min after the stretch will be performed to determine what the immediate and later effects are. In order to perform all of these trials, you will come to the lab twice, once to familiarise you with the equipment and protocol and second, to gather data.

The information required:

Information on the impact of stretching to muscle activation, mechanical properties and force production will enable researchers to determine positive and negative consequences of pre-performance stretching to performance and injury.

There are no serious health risks from the testing, although a small risk of muscle-tendon injury always exists when maximal contractions are performed. You will perform these contractions on a high-quality strength testing machine after a full warm-up, so the risk of injury is very low.

What will happen to the information?

The data from the tests will be stored on a computer in a locked office to maintain confidentiality. The identity of each participant (you) will remain anonymous throughout the research process. I will assign a number for your data and keep your data stored in a locked storage facility. From then on you will be known only by your number. This will prevent anyone else from knowing your results. Therefore, all data will be anonymous (be aware that in certain situations, e.g. illegal activities, anonymity cannot be achieved). The results will be aggregated (i.e. stored as averages), and if the study is publicly disseminated (e.g. published); it will not be possible to identify you or anyone else who participated in the study.

Not sure about participating?

If you do not want to participate, that is okay, you have the right not to participate. You can also stop at any time if you do not want to finish the study; just let me know when you are ready to stop.

Your valued input:

I can make my results available to you when I have finished my study by sending you a short summary. Please let me know if you would like me to do this.

Contact the Researcher:

I hope the above information is helpful to you and gives you a better understanding and insight into my research project. Please feel free to contact me at any time if you have any questions.

Tony Kay
Senior Lecturer in Sport & Exercise Biomechanics
Sport, Exercise & Life Science
School of Health
The University of Northampton
Park Campus
Boughton Green Road
Northampton
NN2 7AL
Tel: [REDACTED]
Email: [REDACTED]

Who has checked this research?

The School of Health Ethics Advisory Panel has approved this study.

The University of Northampton's Combined Liability Insurance Policy provides indemnity for students of the institution carrying out research work (such as questionnaires and interviews) as part of their course.

POSTER ADVERTISEMENT
ARE YOU INTERESTED IN BEING A PARTICIPANT FOR RESEARCH IN SPORT &
EXERCISE BIOMECHANICS?

**We want to understand how maximal contractions affect our ability to develop strong
muscle forces.**

While many of us do our stretches before we play sport, recent evidence suggests it might have more negative consequences than positive. However, the conditions under which stretching has a negative impact are not known. Researchers within the field of Sport & Exercise Science will examine the impact of preconditioning the calf muscle and Achilles tendon using concentric contractions to determine if this removes possible negative effects of stretch in a study running from January-February 2008. Participants are asked to volunteer for the study which will take place in the Biomechanics laboratory on the sports hall on Park Campus. You may withdraw from the study at any time; withdrawal will not incur any negative consequences for you.

You will be the first to learn how preconditioning affects your sporting performance, and have the opportunity to see the latest scientific techniques including ultrasound imaging and state-of-the-art strength testing and muscle activity recording set-ups. These tools will be used to examine muscle strength, tendon elongation and muscle activation after stretching of various durations.

There are no serious health risks from the testing, although a small risk of muscle-tendon injury always exists when maximal contractions are performed. You will perform these contractions on a high-quality strength testing machine after a full warm-up, so the risk of injury is very low.

Testing will take place on 2 days over a period of 1 week.

For more information, please contact me on either the mobile number below or come to my office to discuss the aims and protocol of study further.

Thank you.

Tony Kay: [REDACTED]
SH2 (office), Sports Hall
Park Campus

Activity:	Muscle-tendon testing on isokinetic dynamometer	Reference No:	
		Assessed By:	T. Kay
Location:	PERFORMANCE ANALYSIS AND SPORT BEHAVIOUR LABORATORY (LAB 2) EVERDON BUILDING, PARK CAMPUS	Approved By:	
		Issue Date:	22:02:2007
		Revision Date:	22:02:2008

Hazard	Consequences	Persons affected	Existing Control Measures (Where appropriate)	Severity	Likelihood	Total Risk	Additional Measures (Where appropriate)	Severity	Likelihood	Total Risk
TESTING PROTOCOL										
Isokinetic dynamometer	Musculotendinous and joint injury	Participants	Manual and electronic stops on dynamometer.	3	3	9	Staff should be given suitable and sufficient information and training. Participants given electronic stop button.	3	2	6
EMG	Cuts & infection	Participants	Manual and electronic stops on dynamometer.	3	3	9	Staff should be given suitable and sufficient information and training. Participants given electronic stop button.	3	2	6
ELECTRICAL										
Defective plugs, sockets, flex's and equipment	Electric shock, burns, electrical fires, and death	Staff and participants	PAT testing cycle in place. Mains testing in place. Risk assessments for individual items and activities are available.	4	1	4	Staff given suitable and sufficient information and training on electrical hazards. Electrical equipment should be selected with consideration for the working environment and the task being undertaken	4	1	4

Hazard	Consequences	Persons affected	Existing Control Measures (Where appropriate)	Severity	Likelihood	Total Risk	Additional Measures (Where appropriate)	Severity	Likelihood	Total Risk
Water spilt on electrical equipment	Electric shock, burns, electrical fires, and death	Staff and participants	Fluid to exercising participants only. Where possible do not consume fluid during exercise. Whilst on treadmill ensure participant is not given water.	4	1	4				
COSHH										
Cleaning chemicals	Ill health effects, death	Staff, students, agency staff, cleaners, contractors, visitors and participants	Please refer to the COSHH/DSEAR Policy and Procedures and individual COSHH assessments for existing control measures. Please refer to risk assessments for individual items and activities.	3	3	9	Staff should follow the instructions given on the packing Cleaning chemicals should always be kept in the cleaning cupboard unless in use			
Biohazard	Ill health effects, death	Staff and participants	Designated biohazard area and warning signs in place. Screen participants, exclude participants at risk. Please refer to risk assessments for individual items and activities.	4	2	8	Ensure all non-sharps are placed and stored correctly. Wash and disinfect biohazard area daily.	4	2	8

Hazard	Consequences	Persons affected	Existing Control Measures (Where appropriate)	Severity	Likelihood	Total Risk	Additional Measures (Where appropriate)	Severity	Likelihood	Total Risk
WORK ENVIRONMENT										
Poor heating	Muscle-tendon strain	Participants	Air conditioning units, with thermostatic control, are in the lab	1	2	2	Heating provision should be checked and maintained regularly by Estates	1	2	2
Trailing wires and cables, poor storage of materials	Slips trips and falls, falling objects	Staff and participants		3	3	9	Wires and cables should not be placed over walkways and are taped to ground. Bags and coats locked in cabinet. Chairs placed under tables when not in use.	3	1	3
SUPERVISION										
Lack of supervision	Property damage, injury, illness	Participants	Restrict access to technician and academic staff working hours. Maximum of 1 non-member of staff present in the lab.	3	1	3				

RISK ASSESSMENT MATRIX

RISK						
Severity	5	5	10	15	20	25
	4	4	8	12	16	20
	3	3	6	9	12	15
	2	2	4	6	8	10
	1	1	2	3	4	5
		1	2	3	4	5
		Likelihood				

SEVERITY	
5	Multiple fatality
4	Fatality
3	Major injury
2	Minor injury
1	Negligible impact

LIKELIHOOD	
5	Almost Certain
4	Probable
3	Possible
2	Remote
1	Improbable

133

The aim is to reduce the risk by prevention or control measures so far as is reasonably practicable.

Explanatory Note:

Risk

16-25	Very high (Do not proceed without authorisation from the Directorate)
12-15	High
6-10	Medium
1-5	Low

Likelihood

Almost certain	Self explanatory
Probable	More likely than not to occur
Possible	Has the potential to occur
Remote	Unlikely to occur
Improbable	Occurrence is extremely unlikely

Severity

Multi fatality	Self explanatory
Fatality	Self explanatory
Major injury	Reportable incident under RIDDOR such as fracture of bones, dislocation, amputation, occupational diseases (e.g. asthma, dermatitis), loss of sight.
Minor injury	First aid administered. This would include minor, cuts, bruising, abrasions and strains or sprains of ligaments, tendons, muscles
Negligible impact	Self explanatory

Appendix 3

Repeated Measures ANOVA tables

Study 1

Table 3.4.2. Repeated measures ANOVA for normalised moment during maximal concentric plantarflexion trials.

Source	Measure		Type III Sum of Squares	df	Mean Square	F	Sig.
Concentric moment	90% ROM	Sphericity Assumed	208.375	2	104.188	5.630	.009
	70% ROM	Sphericity Assumed	185.854	2	92.927	3.711	.037
	50% ROM	Sphericity Assumed	168.700	2	84.350	4.143	.027

Table 3.4.3. Repeated measures ANOVA for normalised gastrocnemius lateralis (GL), gastrocnemius medialis (GM), soleus (Sol), triceps surae (TS) and tibialis anterior (TA) electromyographic (EMG) amplitude.

Source	Measure		Type III Sum of Squares	df	Mean Square	F	Sig.
GL	90% ROM	Sphericity Assumed	2919.823	2	1459.912	8.756	.001
	70% ROM	Sphericity Assumed	1285.762	2	642.881	5.423	.011
	50% ROM	Sphericity Assumed	1600.920	2	800.460	2.782	.080
GM	90% ROM	Sphericity Assumed	1303.052	2	651.526	2.881	.074
	70% ROM	Greenhouse-Geisser	496.429	1.4	354.412	1.393	.265
	50% ROM	Sphericity Assumed	1429.930	2	714.965	3.596	.042
SOL	90% ROM	Sphericity Assumed	4175.808	2	2087.904	9.930	.001
	70% ROM	Sphericity Assumed	1061.200	2	530.600	2.145	.137
	50% ROM	Sphericity Assumed	480.867	2	240.434	.903	.418
TS	90% ROM	Sphericity Assumed	2180.710	2	1090.355	9.437	.001
	70% ROM	Sphericity Assumed	782.092	2	391.046	3.293	.053
	50% ROM	Sphericity Assumed	1051.829	2	525.915	3.024	.066
TA	90% ROM	Sphericity Assumed	11.954	2	5.977	.803	.458
	70% ROM	Sphericity Assumed	9.609	2	4.805	.827	.448
	50% ROM	Sphericity Assumed	2.976	2	1.488	.293	.748

Table 3.4.4. Repeated measures ANOVA for moment during passive dorsiflexion trials.

Source	Measure		Type III Sum of Squares	df	Mean Square	F	Sig.
Passive Moment	90% ROM	Greenhouse-Geisser	187.558	1.2	154.082	4.306	.048
	70% ROM	Sphericity Assumed	254.823	2	127.412	5.901	.008
	50% ROM	Greenhouse-Geisser	70.386	1.4	49.916	4.211	.043
	30% ROM	Greenhouse-Geisser	65.863	1.2	55.865	3.780	.065
	10% ROM	Greenhouse-Geisser	29.259	1.3	21.879	1.434	.257

Table 3.4.5. Repeated measures ANOVA for gastrocnemius medialis (GM) muscle length, Achilles tendon length and stiffness during maximal concentric plantarflexion trials.

Source	Measure		Type III Sum of Squares	df	Mean Square	F	Sig.
Achilles Tendon Length	90% ROM	Sphericity Assumed	69.725	2	34.863	5.351	.013
	70% ROM	Sphericity Assumed	60.679	2	30.340	4.950	.017
	50% ROM	Sphericity Assumed	47.853	2	23.926	5.550	.011
GM Muscle Length	90% ROM	Sphericity Assumed	69.725	2	34.86	5.351	.013
	70% ROM	Sphericity Assumed	60.679	2	30.34	4.950	.017
	50% ROM	Sphericity Assumed	47.853	2	23.93	5.550	.011
Achilles Tendon Stiffness	90% ROM	Greenhouse-Geisser	4.352	1.34	3.245	.608	.494

Table 3.4.6. Repeated measures ANOVA for Achilles tendon and gastrocnemius medialis (GM) muscle length during passive dorsiflexion trials.

Source	Measure		Type III Sum of Squares	df	Mean Square	F	Sig.
Achilles length	90% ROM	Sphericity Assumed	10.511	2	5.255	1.842	.180
	70% ROM	Sphericity Assumed	14.407	2	7.203	1.836	.181
	50% ROM	Sphericity Assumed	28.884	2	14.442	2.877	.076
	30% ROM	Sphericity Assumed	21.583	2	10.792	2.103	.144
	10% ROM	Sphericity Assumed	12.539	2	6.269	1.090	.352
GM length	90% ROM	Sphericity Assumed	5.165	2	2.583	2.547	.099
	70% ROM	Sphericity Assumed	5.404	2	2.702	1.930	.167
	50% ROM	Sphericity Assumed	9.772	2	4.886	2.699	.088
	30% ROM	Sphericity Assumed	8.324	2	4.162	1.659	.211
	10% ROM	Sphericity Assumed	4.265	2	2.132	.628	.542

Study 2

Table 4.4.1. Repeated measures ANOVA for normalised moment during maximal concentric plantarflexion trials.

Source	Measure		Type III Sum of Squares	df	Mean Square	F	Sig.
Concentric moment	90% ROM	Sphericity	1274.321	3	424.774	11.62	.000
		Assumed					
	70% ROM	Sphericity	973.925	3	324.642	12.53	.000
		Assumed					
	50% ROM	Sphericity	831.018	3	277.006	9.94	.000
		Assumed					

Table 4.4.2. Repeated measures ANOVA for normalised gastrocnemius lateralis (GL), gastrocnemius medialis (GM), soleus (Sol), triceps surae (TS) and tibialis anterior (TA) electromyographic (EMG) amplitude during maximal concentric plantarflexion trials.

Source	Measure		Type III Sum of Squares	df	Mean Square	F	Sig.
GL	90% ROM	Sphericity	7811.336	3	2603.779	11.249	.000
		Assumed					
		Sphericity	6300.353	3	2100.118	9.888	.000
GM	70% ROM	Assumed	3293.658	3	1097.886	3.703	.018
		Sphericity	6479.943	3	2159.981	11.454	.000
		Assumed	2372.376	1.79	1327.295	5.330	.014
SOL	50% ROM	Greenhouse-Geisser	2532.274	2.03	1245.396	4.843	.015
		Sphericity	3948.682	3	1316.227	5.376	.004
		Assumed	2033.544	3	677.848	4.648	.008
TS	70% ROM	Sphericity	1984.850	3	661.617	5.565	.003
		Assumed	5130.097	3	1710.032	10.891	.000
		Sphericity	3028.401	1.75	1732.744	9.657	.001
TA	50% ROM	Greenhouse-Geisser	2684.539	3	894.846	7.596	.000
		Sphericity	109.370	3	36.457	6.312	.001
		Assumed	39.520	1.63	24.231	2.572	.106
TA	90% ROM	Sphericity	42.401	1.62	26.182	2.805	.090
		Assumed					
		Sphericity					

Table 4.4.3. Repeated measures ANOVA for normalised joint moment during passive trials.

Source	Measure		Type III Sum of Squares	df	Mean Square	F	Sig.
Passive moment	90% ROM	Sphericity	204.686	3	68.229	4.84	.006
		Assumed					
		Sphericity	284.893	3	94.964	6.52	.001
Passive moment	70% ROM	Assumed	149.553	2.2	68.045	5.43	.008
		Sphericity					
		Greenhouse-Geisser					

Table 4.4.4. Repeated measures ANOVA for gastrocnemius medialis (GM) muscle length, Achilles tendon length and stiffness during maximal concentric plantarflexion trials.

Source	Measure		Type III Sum of Squares	df	Mean Square	F	Sig.
GM Muscle Length	90% ROM	Greenhouse-Geisser	49.338	1.605	30.735	2.018	.166
	70% ROM	Greenhouse-Geisser	28.914	1.700	17.005	1.435	.259
	50% ROM	Greenhouse-Geisser	32.056	1.87	17.175	2.21	.136
Achilles Tendon Length	90% ROM	Sphericity Assumed	10.119	3	3.373	.754	.527
	70% ROM	Sphericity Assumed	5.216	3	1.739	.427	.735
	50% ROM	Sphericity Assumed	7.572	3	2.524	.800	.502
Achilles Tendon Stiffness	90% ROM	Greenhouse-Geisser	16.420	1.847	8.890	8.208	.002

Table 4.4.5. Repeated measures ANOVA for Achilles tendon length and gastrocnemius medialis (GM) muscle length during passive trials.

Source	Measure		Type III Sum of Squares	df	Mean Square	F	Sig.
Achilles Tendon Length	90% ROM	Sphericity Assumed	3.067	3	1.022	.311	.817
	70% ROM	Sphericity Assumed	5.552	3	1.851	.577	.633
	50% ROM	Sphericity Assumed	13.014	3	4.338	1.164	.335
GM Muscle Length	90% ROM	Sphericity Assumed	3.047	3	1.016	.316	.814
	70% ROM	Sphericity Assumed	5.499	3	1.833	.589	.626
	50% ROM	Sphericity Assumed	12.846	3	4.282	1.194	.324

Study 3

Table 5.4.1. Repeated measures ANOVA for normalised moment during maximal concentric plantarflexion trials.

Source	Measure		Type III Sum of Squares	df	Mean Square	F	Sig.
Concentric moment	90% ROM	Sphericity Assumed	942.932	3	314.311	11.48	.000
	70% ROM	Sphericity Assumed	664.347	3	221.449	6.67	.001
	50% ROM	Sphericity Assumed	437.809	3	145.936	7.54	.000

Table 5.4.2. Repeated measures ANOVA for normalised gastrocnemius lateralis (GL), gastrocnemius medialis (GM), soleus (Sol), triceps surae (TS) and tibialis anterior (TA) electromyographic (EMG) amplitude during maximal concentric plantarflexion trials.

Source	Measure		Type III Sum of Squares	df	Mean Square	F	Sig.
GL	90% ROM	Sphericity Assumed	1546.759	3	515.586	4.405	.008
	70% ROM	Sphericity Assumed	2988.438	3	996.146	5.258	.003
	50% ROM	Sphericity Assumed	1135.090	3	378.363	3.028	.038
GM	90% ROM	Sphericity Assumed	3997.231	3	1332.410	21.323	.000
	70% ROM	Sphericity Assumed	3015.770	3	1005.257	9.058	.000
	50% ROM	Sphericity Assumed	1679.319	3	559.773	6.631	.001
SOL	90% ROM	Sphericity Assumed	2532.564	3	844.188	6.839	.001
	70% ROM	Sphericity Assumed	1298.022	3	432.674	2.609	.063
	50% ROM	Sphericity Assumed	115.883	3	38.628	.309	.819
TS	90% ROM	Sphericity Assumed	2334.735	3	778.245	13.532	.000
	70% ROM	Sphericity Assumed	2017.612	3	672.537	7.271	.000
	50% ROM	Sphericity Assumed	702.435	3	234.145	3.034	.039
TA	90% ROM	Sphericity Assumed	8.391	3	2.797	1.223	.314
	70% ROM	Greenhouse-Geisser	9.124	1.85	4.926	1.329	.282
	50% ROM	Sphericity Assumed	2.958	3	.986	.611	.612

Table 5.4.3. Repeated measures ANOVA for normalised joint moment during passive trials.

Source	Measure		Type III Sum of Squares	df	Mean Square	F	Sig.
Passive moment	90% ROM	Greenhouse-Geisser	839.667	1.86	452.240	12.149	.000
	70% ROM	Greenhouse-Geisser	646.468	1.86	348.544	12.731	.000
	50% ROM	Greenhouse-Geisser	347.199	1.86	187.251	9.613	.001

Table 5.4.4. Repeated measures ANOVA for gastrocnemius medialis (GM) muscle length, Achilles tendon length and stiffness during maximal concentric plantarflexion trials.

Source	Measure		Type III Sum of Squares	df	Mean Square	F	Sig.
GM Muscle Length	90% ROM	Sphericity Assumed	33.460	3	11.153	4.21	.010
	70% ROM	Greenhouse-Geisser	29.506	1.865	15.822	2.38	.114
	50% ROM	Greenhouse-Geisser	27.127	1.849	14.668	2.23	.130
Achilles Tendon Length	90% ROM	Sphericity Assumed	31.278	3	10.426	4.68	.006
	70% ROM	Greenhouse-Geisser	27.036	1.849	14.626	2.54	.101
	50% ROM	Greenhouse-Geisser	27.395	1.919	14.275	2.47	.105
Achilles Tendon Stiffness	90% ROM	Sphericity Assumed	23.391	3	7.797	5.34	.004

Table 5.4.5. Repeated measures ANOVA for Achilles tendon length and gastrocnemius medialis (GM) muscle length during passive trials.

Source	Measure		Type III Sum of Squares	df	Mean Square	F	Sig.
Achilles Tendon Length	90% ROM	Sphericity Assumed	9.112	3	3.037	2.78	.050
	70% ROM	Sphericity Assumed	11.647	3	3.882	3.17	.032
	50% ROM	Sphericity Assumed	14.047	3	4.682	3.58	.020
GM Muscle Length	90% ROM	Sphericity Assumed	8.396	1.48	5.679	1.43	.255
	70% ROM	Sphericity Assumed	9.086	3	3.029	2.40	.079
	50% ROM	Sphericity Assumed	11.908	3	3.969	3.04	.038