

MAXIMUM POWER POINT TRACKING FOR VARIABLE-SPEED FIXED-PITCH SMALL WIND TURBINES

Ghanim PUTRUS
Northumbria University
United Kingdom
ghanim.putrus@unn.ac.uk

Mahinsasa NARAYANA
Northumbria University
United Kingdom
mahinsasa.narayana@unn.ac.uk

Milutin JOVANOVIC
Northumbria University
United Kingdom
milutin.jovanovic@unn.ac.uk

Pak Sing LEUNG
Northumbria University
United Kingdom
ps.leung@unn.ac.uk

ABSTRACT

Variable-speed, fixed-pitch wind turbines are required to optimize power output performance without the aerodynamic controls. A wind turbine generator system is operated such that the optimum points of wind rotor curve and electrical generator curve coincide. In order to obtain maximum power output of a wind turbine generator system, it is necessary to drive the wind turbine at an optimal rotor speed for a particular wind speed. In fixed-pitch variable-speed wind turbines, wind-rotor performance is fixed and the restoring torque of the generator needs to be adjusted to maintain optimum rotor speed at a particular wind speed for maximum aerodynamic power output. In turbulent wind environment, control of wind turbine systems to continuously operate at the maximum power points becomes difficult due to fluctuation of wind speeds. Therefore, special emphasis is given to operating at maximum aerodynamic power points of wind rotor. In this paper, the performance of a Fuzzy Logic Maximum Power Point Tracking (MPPT) controller is investigated for applications on variable-speed fixed-pitch small-scale wind turbines.

INTRODUCTION

Variable-speed wind turbines are generally characterized as having higher efficiency than fixed-speed wind turbines and hence are becoming more popular, particularly for small wind turbines. Typically, variable-speed wind turbines are aerodynamically controlled, usually by using power electronics, to regulate the torque and speed of the turbine in order to maximize the output power. Variable-pitch aerodynamically controlled wind turbines are more costly and complex. Therefore, variable-speed fixed-pitch approach is becoming more popular for low cost construction and is the most common scheme for small wind turbines. In this scheme, a MPPT control mechanism is used to control the restoring torque of the electrical generator for optimum operation of the wind turbine system [1]. The performance of variable-speed fixed-pitch wind turbines could be optimized without the need for a complex aerodynamic control. These turbines are usually operated such that the relevant optimum points of wind rotor curve and electrical generator curve coincide, as shown in Figure 1. Therefore, in order to obtain maximum output power from the turbine, it is necessary to drive it at an optimal rotor speed for a particular wind speed.

CONTROL STRATEGIES

Wind speed, turbine rotational speed and turbine rotor characteristics are the main factors that determine the maximum power points. The electrical-generator characteristics may be used in order to control the restoring torque to track the optimum operation points. If wind speed is varied from V_1 to V_2 , the rotor speed should be changed from ω_1 to ω_2 for optimum operation of the wind turbine (see Figure 1). However, rotational speed of the wind turbine cannot be changed instantaneously. Usually, a controller that employ wind speed sensor (or in some cases, sensor-less control) is used to control the wind turbine. In systems that employ wind speed sensors, the sensor provides the reference signal to the MPPT controller. This reference is compared with the power extracted from the wind energy converter. In sensor-less control technique, no anemometer is used to provide the wind speed information; hence, it is essential to estimate the wind speed. The generator output frequency and power or torque mapping techniques are used to track the MPP [2]. Another way for MPP tracking is the use of "searching" method, which is a suitable strategy for small wind turbines [3, 4]. The latter operates without knowledge of system parameters. The output power is used as feedback signal for the perturbation & observation algorithm, which is used to find the maximum power point of the system.

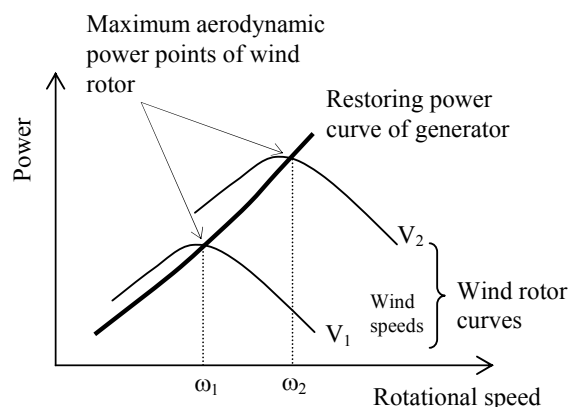

Figure 1- Operating points of wind power system

AERODYNAMIC CHARACTERISTICS OF THE ROTOR

Based on the wind turbine aerodynamic behaviour, the turbine catches only a part of the kinetic energy contained in the wind [5]; that is:

$$P_a = \frac{1}{2} \cdot \rho \cdot \pi \cdot R^2 \cdot v^3 \cdot C_p \quad (1)$$

Where P_a is captured power by the rotor, R is the radius of the rotor, ρ is the air density and v is the speed of the incident wind. The proportion of the useful power is defined by the power coefficient C_p , which for a given wind rotor depends on the pitch angle of the rotor blades and on the tip speed ratio (λ) defined as:

$$\lambda = \frac{\omega \cdot R}{v_s} \quad (2)$$

where ω is the rotational speed of the rotor

The rotor aerodynamic characteristics are represented by the $C_p - \lambda$ relationship. C_p has a maximum value for an optimal tip speed ratio value (λ_{opt}). Near the optimum tip speed ratio, the power extraction is maximal at any wind speeds that results in the maximum power coefficient. For variable speed wind turbines; when wind speed varies, the rotor speed should be adjusted proportionally to maintain optimum tip speed ratio for maximum power extraction. Using equation (1) aerodynamic torque (T_a) by a wind rotor can be obtained as follows:

$$T_a = \frac{1}{2} \cdot \rho \cdot \pi \cdot R^3 \cdot v^2 \cdot \frac{C_p}{\lambda} \quad \text{where } \lambda = \frac{\omega \cdot R}{v}$$

$$T_a = \frac{1}{2} \cdot \rho \cdot \pi \cdot R^3 \cdot v^2 \cdot C_T, \quad (3)$$

Where C_T - the torque coefficient, T_a - Aerodynamic torque of rotor.

The C_p & $C_T - \lambda$ relationship of the wind turbine is shown in Figure 2.

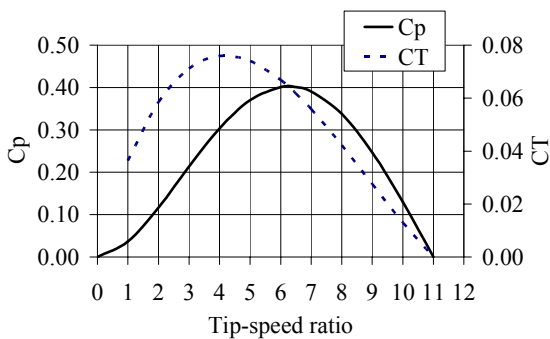

Figure 2- Wind rotor characteristics

The, aerodynamic torque of a wind turbine is function of wind speed (v) and rotational speed (ω) of the rotor. For wind turbine-generator systems with a gearbox, the mechanical torque (the torque supplied to the generator) can be expressed as:

$$T = K \cdot f(v, \omega)$$

where K is the gear ratio of the gearbox.

For small scale wind turbine generators, there is no gearbox and hence $K=1$.

RESTORING TORQUE OF THE GENERATOR

Restoring torque of an electric generator can be derived from the electromagnetic torque developed by the rotor of generator. The generator torque (which is define as a negative motor torque) is a function of generator current (I_G), magnetic flux linkage and number of pole pairs [6, 7]. For a particular generator, magnetic flux linkage and number of pole pairs are fixed parameters. Therefore, restoring torque of a generator (T_e) can be varied by controlling the current.

$$T_e = f(I_G)$$

MAXIMUM POWER POINT TRACKING CONTROL MECHANISM

Input mechanical power curve of the generator, would be adjusted to tally with the maximum power points of the rotor curves by varying the effective electric load on the generator. The system output power is interlaced with the wind turbine aerodynamic power and rate of change in the mechanically stored energy. As the efficiency of the electric generator is variable, searching method estimation of the aerodynamic power from the electric output of wind turbine system is difficult.

For maximum power tracking:

$$T_a = J \cdot \dot{\omega} + T_e \quad (4)$$

Then,

$$P_a = J \cdot \dot{\omega} \cdot \omega + \frac{P_e}{\eta} \quad (\text{as } P_e = \eta \cdot T_e \cdot \omega) \quad (5)$$

where J is Momentum of inertia of rotating parts, η is the efficiency of the electric generator, P_e is the power output of the generator.

The function of Maximum power point tracker is to provide the required load on the generator for optimum operation of the system. A schematic diagram of the Maximum Power point Tracker is shown in Figure 3.

By considering the Buck/Boost DC-DC converter (shown in Figure 3);

Voltage ratio

$$V_B = -V_G \left(\frac{D}{1-D} \right) \quad (6)$$

and the corresponding current

$$I_B = -I_G \left(\frac{1-D}{D} \right) \tag{7}$$

where $D = \left(\frac{T_{on}}{T_{on} + T_{off}} \right)$ (8)

V_B is voltage at DC bus, V_G is voltage at generator side, I_B is current flow towards the DC bus, I_G is current flow from the generator side (see Figure 3).

Since the duty ratio "D" is between 0 and 1 the output current and voltage can vary between lower or higher than the input voltage in magnitude. The negative sign indicates a reversal of the output voltage.

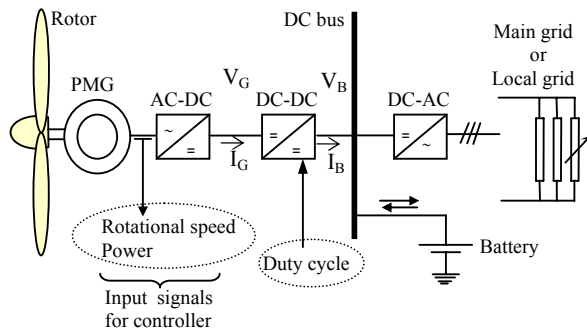

Figure 3- Schematic of small wind power system

FUZZY LOGIC CONTROLLER

Fuzzy logic is derived from Fuzzy set theory dealing with reasoning that is approximated (rather than precisely deduced) from classical predicate logic. Fuzzy Logic rules are used to control the restoring torque of the generator by considering $d\omega/dt$ and $dP/d\omega$. The control criterion is demonstrated in Figure 4. Related Fuzzy sets and Fuzzy rules are presented in Figure 5 and Table 1.

Where;

- DH- Decelerate High
- DL- Decelerate Low
- ST- Steady
- AL- Accelerate Low
- AH- Accelerate High
- RH- Reduce High
- RM- Reduce Medium
- RL- Reduce Low
- NC- Not Change
- UL- Upgrade Low
- UM- Upgrade Medium
- UH- Upgrade High

For a particular wind speed, rotational speed and power output should be measured by considering time interval 't' and then varying the rate of change value of 'D' (Δd) by using "fuzzy logic".

$$D_2 = D_1 + \Delta d \tag{9}$$

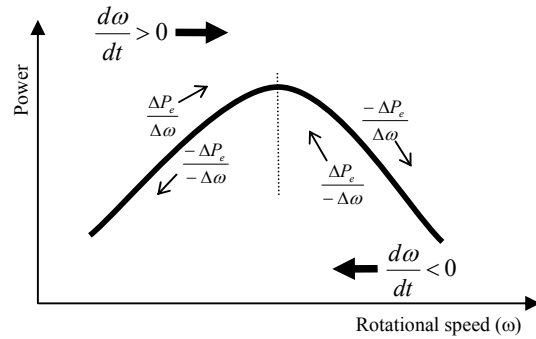

Figure 4- Control criteria

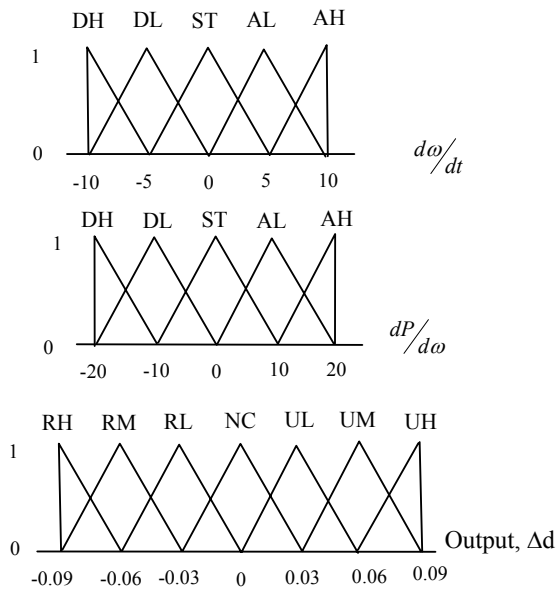

Figure 5- Related Fuzzy sets

Table1- Fuzzy rules

Inputs		output
$d\omega/dt$	$dP/d\omega$	Δd
DH	DH	NC
DH	DH	UM
DL	DH	NC
DL	DH	UM
DL	DL	UM
DL	DL	NC
ST	DL	NC
AL	DL	UL
AH	DL	UM
DH	ST	NC
DL	ST	NC
ST	ST	NC

Inputs		Output
$d\omega/dt$	$dP/d\omega$	Δd
AL	ST	NC
AH	ST	NC
DH	AL	RM
DL	AL	RL
ST	AL	NC
AL	AL	NC
AH	AL	RM
DH	AH	RH
DL	AH	RM
ST	AH	NC
AL	AH	RM
AH	AH	NC

SIMULATION STUDY

A small wind turbine produced at the National Engineering Research & Development Centre (NERDC) in Sri Lanka was simulated in MATLAB/SIMULINK using measured wind speed data in a turbulent wind conditions. System specifications are given in the Appendix. Performances of system with the Fuzzy Logic controller and fixed voltage system were compared. Simulated performances are shown in Figure 5.

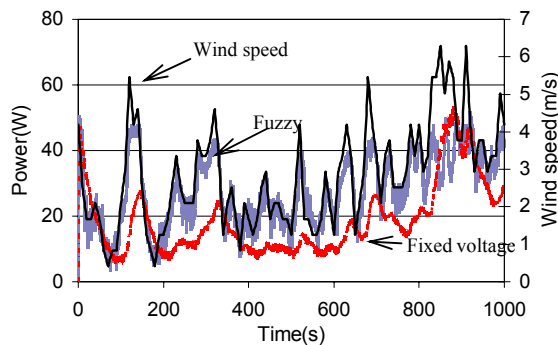

Figure 5- Simulated performance of the wind turbine

Simulated results show that, system with Fuzzy Logic controller performs better than that with fixed voltage system. With the given wind speed data, energy output over 1000 s period is 2793.52 J with a Fuzzy controller and 18881.39 J with a fixed voltage controller. That is, 47% more energy can be generated by the system with a Fuzzy controller.

DISCUSSION & CONCLUSION

Techniques that employ wind sensors are relatively expensive, but they perform well with wind speed variations, particularly when the control system responds quickly to variation in wind conditions. However, in practice it is difficult to accurately measure wind speed by an anemometer installed close to the wind turbine, because the wind turbine experience different forces due to wake rotation. Therefore, it is useful to here a sensorless control strategy for small wind turbine systems that operate without predetermined turbine characteristics. "Perturbation & observation searching method" operates without knowledge of system parameters. However, it is difficult to acquire optimum operating points from outputs of the wind turbine, as mechanically stored energy is interlaced with the aerodynamic power of wind rotor. In this paper, fuzzy logic based MPPT control system is introduced for small wind turbines. Fuzzy sets and fuzzy rules were developed by considering qualitative quantities of wind turbine outputs to track optimum operating points of the system. Research outcome shows that the proposed Fuzzy controller performs better than conventional controller.

APPENDIX

Specifications of the NERDC small wind turbine;	
Capacity	: 100W
Radius of the wind rotor	: 1.105m
Number of blades	: 2
Moment of inertia of rotating parts (I)	: 9.77kg.m ²
Fixed voltage	: 12V

REFERENCES

- [1] E. Muljadi, K. Pierce, P. Migliore, 2000, "Soft-control control for variable-speed stall-regulated wind turbines", *Wind Engineering*, Vol.85, pp277-291.
- [2] K. Tan, S. Islam, June 2004, "Optimum Control Strategies in Energy Conversion of PMSG Wind Turbine System without Mechanical Sensors", *IEEE Transaction on Energy Conversion* Vol.19, No.2, pp392-399.
- [3] E. Koutroulis, K. Kalaitzakis, April 2006, "Design of a Maximum Power Tracking System for Wind-Energy-Conversion Application", *IEEE Transaction on Industrial Electronics*, Vol.53, No.2, pp486-494.
- [4] T. Tanaka, T. Toumiya, 1997, "Output control by hill-climbing method for a small scale wind power generation system", *Renewable Energy*, Vol.12, No.4, pp387-400.
- [5] D Le. Gourieres, 1982, *Wind Power Plants Theory and Design*, Oxford: Pergamon press, pp76-120.
- [6] Md. Arifujjaman, M. T. Iqbal, J. E. Quaice, 2008, "Energy capture by a small wind-energy conversion system", *Applied Energy*, Vol.85, pp41-51.
- [7] S. Morimoto, H. Nakayama, M. Sanada, Jan/Feb 2005, Sensorless output maximization control for variable-speed wind generation system using IPMSG, *IEE transaction on industrial applications*, Vol.41, No.1, pp60-67.