

34th Annual International Conference of the IEEE EMBS
San Diego, California USA, 28 August - 1 September, 2012

Detrending Knee Joint Vibration Signals with a Cascade Moving Average Filter

Suxian Cai, Yunfeng Wu*, Ning Xiang, Zhangting Zhong, Jia He, Lei Shi, and Fang Xu

Abstract—Knee joint vibration signals are very useful for computer-aided analysis of the pathological conditions in the knee. In a vibration arthrometry test, the legs of patients with knee joint disorders may tremble due to the reaction of pain, which causes the baseline wander that may affect the diagnostic decision making in medical study. This paper presents a new type of cascade moving average filter with hierarchical layers to remove the baseline wander in the raw knee joint vibration signals. The first layer of the cascade filter contains two moving averaging operators with the same order. The five tail inputs of the first moving averaging operator are overlapping with the beginning inputs of the successive operator. The piecewise linear trends estimated by the moving average operators in the first layer were smoothed in the final cascade filter output. The simulation results showed that the cascade filter can effectively remove the baseline wander in the raw knee joint vibration signals.

I. INTRODUCTION

The knee joint is the largest synovial hinge joint that is composed of the femur, tibia, fibula, patella, and four ligaments [1]. The knee is more likely to be injured in sports and daily activities than any other joint in the human body.

Osteoarthritis is the most common type of knee arthritis with aging, and is characterized by progressive wearing away of the degenerative cartilage of the knee joint [2]. Articular cartilage is a white, smooth, connective tissue which covers the ends of bones in joints. The stiff yet flexible nature of articular cartilage enables bones of a joint to easily glide over one another with very little friction. Articular cartilage provides smooth and low-friction interaction between the bones of a knee joint [1]. This may allow the withstanding of pressure and weight-bearing brought about by the daily locomotion and athletic activities. As the protective cartilage localized on the medial and lateral articular surfaces of the patella is worn away by osteoarthritis, bare bone is exposed within the joint [3]. Symptoms may include swelling and

pain when bending the knee when a cartilage injury or osteoarthritis occurs.

Diagnosis of knee joint disorders at an early stage is very important because the necessary surgical procedures or therapy options can be applied to slow the degeneration of articular cartilage [4]. The popular diagnostic techniques are arthroscopy and medical imaging. The arthroscopy is a semi-invasive surgical procedure to determine the prognosis and treatment for a variety of orthopaedic conditions [5]. In the arthroscopic surgery, physicians will insert an arthroscope into the joint through a small incision to inspect the interior condition of a knee. Although the arthroscopy is considered as the “gold standard” for relatively low-risk assessment of joint surfaces in orthopaedic prognosis [6], such a semi-invasive approach is not very suited for routine examinations or follow-up monitoring of the effectiveness of a therapy or surgery [7].

The medical imaging tools used for the knee joint diagnosis include digital radiography, computed tomography, and magnetic resonance imaging. Digital radiography is suited for detection of bone injury in the knee, because the X-ray imaging is sensitive to the high-density structure such as femur, tibia, and other bones. X-ray imaging cannot provide a direct appreciation of the status of the articular cartilage, as the cartilage is not visible on X-ray images [8]. Computed tomography is able to provide good visualization of the intra-articular structures, contours of the condyles, and tibial plateau surfaces. However, computed tomography fails to characterize the functional integrity of cartilage, because this technique can only detect the gross defects in the knee [9]. Magnetic resonance imaging, on the other hand, utilizes the property of nuclear magnetic resonance to image nuclei of atoms in the body. The magnetic resonance imaging is able to provide excellent contrast between the soft tissues, which makes it especially useful in detection of cartilage disorder in the knee joint, compared with computed tomography or X-rays [1]. Although the topographical maps obtained from magnetic resonance images may assist in the characterization of *in vivo* orthopaedic conditions, the anatomical images do not support the functional detection of knee joint cartilage sliding condition during the leg bending process.

As an alternative noninvasive method, the vibration arthrometry by recording the knee joint vibration signals during an active knee bending motion [4], [10], [11], can be used in clinical practice for the diagnosis of cartilage pathology [12], [13]. Chu *et al.* [14] established a microphone-based joint auscultation system to detect cartilage damage in degenerative knee joints. However, later research

This work was supported in part by the National Natural Science Foundation of China (grant no. 81101115), the Natural Science Foundation of Fujian Province of China (grant no. 2011J01371), and the Fundamental Research Funds for the Central Universities of China (grants no. 2010121061 and 2010121062). N. Xiang and Z. T. Zhong were supported by the Xiamen University Undergraduate Innovation Training Project Grant and the Fundamental Research Funds for the Central Universities (grant no. CXB2011023). J. He was supported by the Xiamen University undergraduate student innovative experiment project (grant no. XDDC2011007). Asterisk indicates corresponding author.

S. X. Cai, Y. F. Wu, N. Xiang, Z. T. Zhong, J. He, and F. Xu are with the Department of Communication Engineering, School of Information Science and Technology, Xiamen University, 422 Si Ming South Road, Xiamen, Fujian, 361005, China (corresponding author email: y.wu@ieee.org)

L. Shi is with the Department of Orthopedics, Zhongshan Hospital Xiamen University, 201 Hubin South Road, Xiamen, Fujian, 361004, China.

work reported that the microphone-based techniques are not well-suited for clinical application [15], because a typical microphone-based joint auscultation system has a limited frequency response in the audible range, and its sensitivity is commonly diminished by artifacts such as ambient noise and skin friction [1]. Mollan *et al.* [16] then proposed using an accelerometer, instead of a microphone, to measure joint vibration conditions. Recently, the advances of digital signal processing methodology have made significant progress in the measurement and analysis of knee joint vibration signals [7], [13], [17], [18].

In practical application, it is essential to record high-quality knee joint vibration signals for computer-assisted diagnostic analysis [18], [19]. However, surface recording of the knee joint vibration signals with the accelerometer on the subject's patella is susceptible to several different types of artifacts, including baseline wander, electromyogram, random noise, and external interference. Sometimes, patients with knee joint disorders may tremble the legs due to the reaction of pain when they bending the leg in a vibration arthrometry examination, which would cause the baseline wander in the raw vibration signal. The artifact of electromyogram is induced by muscular contractions during the leg bending motion. Random noise due to the thermal effect in the ambient cables and amplifiers is inevitable. The major environmental interference is caused by 50 or 60 Hz power-supply lines and radio-frequency emissions from medical devices. The signal acquisition system driven by direct-current power supply is commonly free of the power-line interference. The aim of the present work is to estimate the baseline wander in the raw knee joint vibration signals, by using a new cascade moving average filter with a hierarchical structure.

II. METHODS

The moving average filter is a type of finite impulse response (FIR) filter that is commonly used to analyze a time series in the time domain. In the filtering procedure, temporal statistics are computed using a few samples of the signal along the time axis, and the samples in a temporal moving window are averaged to produce the output at various points of time [11].

The cascade moving average filter used in the present study is a hierarchical model that combines two successive-placed moving average operators. The first layer of the cascade filter contains a M -order and a N -order moving average operators, as shown in Fig. 1. The K inputs in the tail end of the M -order operator are overlapping with the beginning inputs of the N -order operator. The output of the M -order operator $o_1(i)$ is expressed as

$$\begin{aligned} o_1(i) &= \frac{1}{M} [x(i-1) + \dots + x(i-M)] \\ &= \frac{1}{M} \sum_{m=1}^M x(i-m), \end{aligned} \quad (1)$$

and the output of the following N -order operator $o_2(i)$ can

be written as

$$\begin{aligned} o_2(i) &= \frac{1}{N} [x(i-M+K) + \dots + x(i-M+K-N)] \\ &= \frac{1}{N} \sum_{n=1}^N x(i-M+K-n). \end{aligned} \quad (2)$$

The second hierarchical moving average is designed to smooth the piecewise linear trends obtained from the outputs of two moving average operators in the first layer of the cascade filter. The final output of the cascade moving average filter is given as

$$\begin{aligned} y(i) &= [o_1(i) + o_2(i)]/2 \\ &= \frac{1}{2M} \sum_{m=1}^M x(i-m) + \frac{1}{2N} \sum_{n=1}^N x(i-M+K-n). \end{aligned} \quad (3)$$

By applying the z -transform, we may compute the transfer function $H(z)$ of the cascade moving average filter as

$$\begin{aligned} H(z) = \frac{Y(z)}{X(z)} &= \frac{1}{2M} (z^{-1} + \dots + z^{-M}) + \\ &+ \frac{1}{2N} (z^{-M+K-1} + \dots + z^{-M+K-N}), \end{aligned} \quad (4)$$

where $X(z)$ and $Y(z)$ are the z -transform of the filter input $x(i)$ and output $y(i)$, respectively.

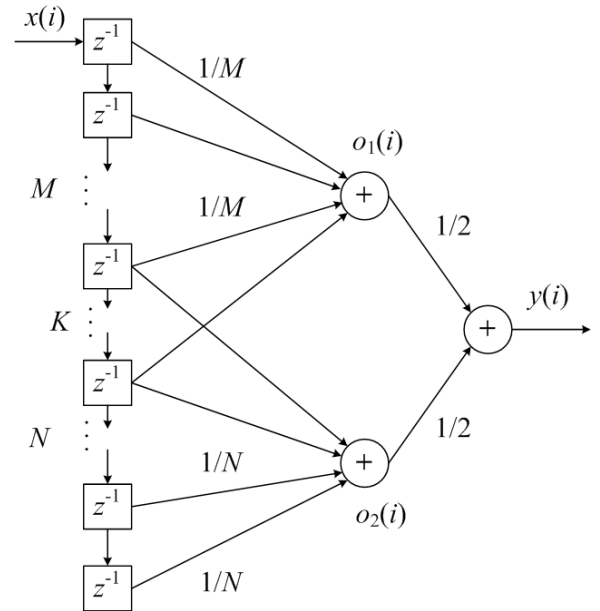

Fig. 1. The hierarchical structure of the cascade moving average filter.

III. EXPERIMENTS

The knee joint vibration signals tested in the experiments were recorded by the research group of Prof. Rangaraj M. Rangayyan from University of Calgary, Canada [10], [12]. The same data set was also investigated in our previous studies [7], [13], [17]–[19]. According to the protocol, each subject was request to sit on a rigid table and bend the leg freely suspended in air. There are eighty-nine subjects recruited in the experiments, including fifty-one healthy adults

and thirty-eight patients with different knee joint disorders. The healthy adults were tested by clinical examinations and the patients were confirmed by medical history or arthroscopic surgery. A miniature accelerometer was attached at the middle patella to record the knee joint vibration signals. Subjects were requested to bend their legs over an angle range of 135° to 0° , and back to 135° in 4 s [10]. The first half of each vibration signal corresponds to leg extension movement, and the second half to leg flexion movement. The knee joint vibration signals were sampled at 2 kHz, and then amplified and digitalized with 12-bit resolution per sample.

In the present study, the two moving average operators in the first layer of the hierarchical model were with the same structure, the orders of which were $M = 20$ and $N = 20$, respectively. The reason for such a design was the symmetry of the leg bending course (135° – 0° – 135°) in the protocol. The number of the overlapping inputs of the moving average operators was set to be $K = 5$. Figure 2 shows the frequency response of the cascade moving average filter. The simulations of baseline wander removal in the eighty-nine knee joint vibration signals were implemented in Matlab version 2011b (The MathWorks, Inc.).

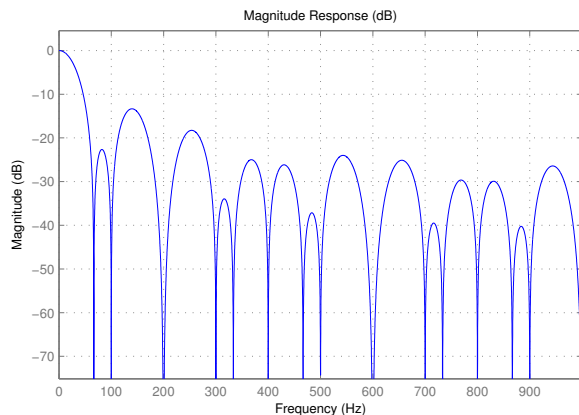

Fig. 2. The frequency response of the cascade moving average filter.

IV. RESULTS

Figures 3 and 4 plot the results of baseline wander removal in the knee joint vibration signals for a healthy control subject and a patient (male at the age of 42) with Grade IV chondromalacia patellae, respectively. It can be observed from Fig. 3 (b) that the baseline wander in the normal knee joint vibration signal presents relatively more regular in the waveform than that in the abnormal signal shown in Fig. 4 (b). The baseline in Fig. 4 dramatically fluctuates from 1.26–1.8 s, and later from 2.2–2.7 s, which corresponds the pathological diagnosis angle at 85 – 120° . The drift of baseline in Fig. 4 (b) was the periodic power-supply interference at 60 Hz and its harmonics, but the baseline wander in Fig. 4 (b), on the other hand, was caused by the painful trembling of the leg when the knee bent through the degenerative joint surface. Nevertheless, the cascade moving average filter effectively removed the drifts in the raw knee joint vibration

records, and the baselines of the process signals were located back to the isoelectric line (the zero level).

V. CONCLUSION

Removal of the drift in the baseline is crucial for the posterior computer-aided diagnostic analysis. The paper describes a cascade moving average filter with a hierarchical structure in order to estimate the baseline wander in the knee joint vibration signals. Two moving average operators with the same order and five overlapping inputs in the first layer were used to estimate the piecewise linear trends, and the cascade filter output in the second layer equally combines and smooths the outputs of the moving average operators. The simulation experiments of filter performance on the eighty-nine knee joint vibration signals displayed the effectiveness of the cascade moving average filter. The future work should direct the real-time processing of the artifacts in the knee joint vibration arthrometry test.

ACKNOWLEDGMENT

The authors would like to thank Prof. Rangaraj M. Rangayyan, Dr. Cyril B. Frank, and Dr. Gordon D. Bell from University of Calgary, Calgary, AB, Canada, for the work of data acquisition, and Prof. Sridhar Krishnan from Ryerson University, Toronto, ON, Canada, for technical discussion.

REFERENCES

- [1] Y. F. Wu, S. Krishnan, and R. M. Rangayyan, "Computer-aided diagnosis of knee-joint disorders via vibroarthrographic signal analysis: a review," *Critical Reviews in Biomedical Engineering*, vol. 38, no. 2, pp. 201–224, 2010.
- [2] D. Dejour, W. Vasconcelos, and T. Tavernier, "Patellofemoral osteoarthritis," in *Osteoarthritis of the Knee*, M. Bonnin and P. Chambat, Eds. Paris, France: Springer-Verlag, 2008, pp. 15–33.
- [3] V. J. Vigorita, *Orthopaedic Pathology*. Philadelphia, PA: Lippincott Williams & Wilkins, 1999.
- [4] C. B. Frank, R. M. Rangayyan, and G. D. Bell, "Analysis of knee sound signals for non-invasive diagnosis of cartilage pathology," *IEEE Engineering in Medicine and Biology Magazine*, vol. 9, no. 1, pp. 65–68, 1990.
- [5] F. R. Noyes and C. L. Stabler, "A system for grading articular cartilage lesions at arthroscopy," *American Journal of Sports Medicine*, vol. 17, no. 4, pp. 505–513, 1989.
- [6] R. W. Jackson and I. Abe, "The role of arthroscopy in the management of disorders of the knee: an analysis of 200 consecutive examinations," *Journal of Bone and Joint Surgery-British Volume*, vol. 54-B, no. 2, pp. 310–322, 1972.
- [7] R. M. Rangayyan and Y. F. Wu, "Screening of knee-joint vibroarthrographic signals using statistical parameters and radial basis functions," *Medical & Biological Engineering & Computing*, vol. 46, no. 3, pp. 223–232, 2008.
- [8] Y. Carrillon, "Imaging knee osteoarthritis," in *Osteoarthritis of the Knee*, M. Bonnin and P. Chambat, Eds. Paris, France: Springer-Verlag, 2008, pp. 3–14.
- [9] W. P. Chan, P. Lang, M. P. Stevens, K. Sack, S. Majumdar, D. W. Stoller, C. Basch, and H. K. Genant, "Osteoarthritis of the knee: Comparison of radiography, CT, and MR imaging to assess extent and severity," *American Journal of Roentgenology*, vol. 157, no. 4, pp. 799–806, 1991.
- [10] S. Krishnan, R. M. Rangayyan, G. D. Bell, and C. B. Frank, "Auditory display of knee-joint vibration signals," *Journal of the Acoustical Society of America*, vol. 110, no. 6, pp. 3292–3304, 2001.
- [11] R. M. Rangayyan, *Biomedical Signal Analysis: A Case-Study Approach*. New York, NY: IEEE and Wiley, 2002.
- [12] R. M. Rangayyan, S. Krishnan, G. D. Bell, C. B. Frank, and K. O. Ladly, "Parametric representation and screening of knee joint vibroarthrographic signals," *IEEE Transactions on Biomedical Engineering*, vol. 44, no. 11, pp. 1068–1074, 1997.

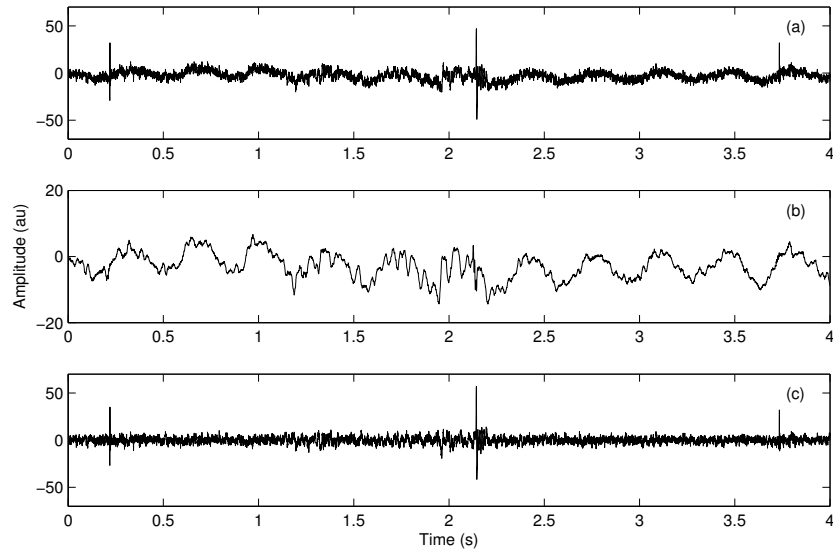

Fig. 3. Subfigures from top to bottom: the raw knee joint vibration signal of a healthy subject, the baseline wander estimated by the cascade moving average filter, and the baseline-wander-free signal of the filter output.

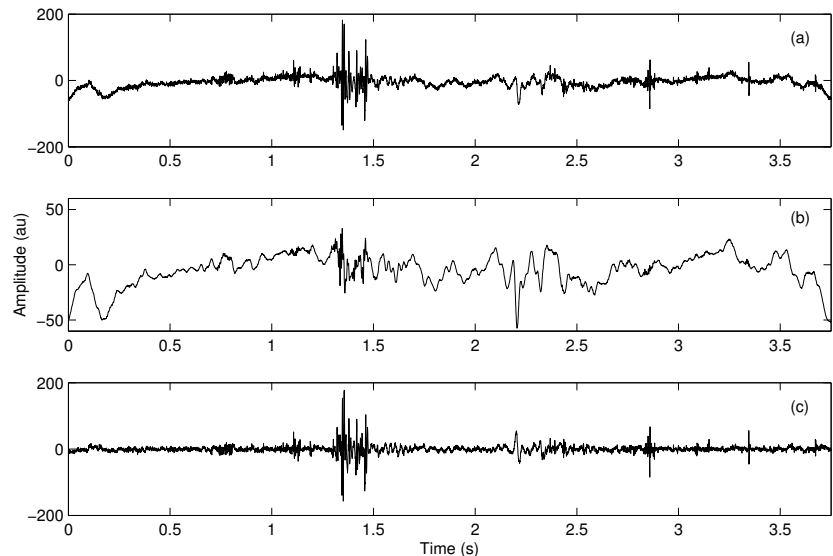

Fig. 4. Subfigures from top to bottom: the raw knee joint vibration signal of a patient (male, age: 42 years old) with Grade IV chondromalacia patellae, the baseline wander estimated, and the baseline-wander-free signal output by the cascade moving average filter.

- [13] R. M. Rangayyan and Y. F. Wu, "Analysis of vibroarthrographic signals with features related to signal variability and radial-basis functions," *Annals of Biomedical Engineering*, vol. 37, no. 1, pp. 156–163, 2009.
- [14] M. L. Chu, I. A. Gradisar, and R. Mostardi, "A noninvasive electroacoustical evaluation technique of cartilage damage in pathological knee joints," *Medical & Biological Engineering & Computing*, vol. 16, pp. 437–442, 1978.
- [15] W. G. Kernohan, D. A. Barr, G. F. McCoy, and R. A. B. Mollan, "Vibration arthrometry in assessment of knee disorders: the problem of angular velocity," *Journal of Biomedical Engineering*, vol. 13, pp. 35–38, 1991.
- [16] R. A. B. Mollan, W. G. Kernohan, and P. H. Watters, "Artefact encountered by the vibration detection system," *Journal of Biomechanics*, vol. 16, no. 3, pp. 193–199, 1983.
- [17] R. M. Rangayyan and Y. F. Wu, "Screening of knee-joint vibroarthrographic signals using probability density functions estimated with Parzen windows," *Biomedical Signal Processing and Control*, vol. 5, no. 1, pp. 53–58, 2010.
- [18] Y. F. Wu and S. Krishnan, "Combining least-squares support vector machines for classification of biomedical signals: a case study with knee-joint vibroarthrographic signals," *Journal of Experimental & Theoretical Artificial Intelligence*, vol. 23, no. 1, pp. 63–77, 2011.
- [19] R. M. Rangayyan, F. Oloumi, Y. F. Wu, and S. X. Cai, "Fractal analysis of knee-joint vibroarthrographic signals via power spectral analysis," *Biomedical Signal Processing and Control*, 2012, doi: 10.1016/j.bspc.2012.05.004.