

ANNALES SCIENTIFIQUES DE L'É.N.S.

M. J. PACÍFICO

A. ROVELLA

Unfolding contracting singular cycles

Annales scientifiques de l'É.N.S. 4^e série, tome 26, n° 6 (1993), p. 691-700

http://www.numdam.org/item?id=ASENS_1993_4_26_6_691_0

© Gauthier-Villars (Éditions scientifiques et médicales Elsevier), 1993, tous droits réservés.

L'accès aux archives de la revue « Annales scientifiques de l'É.N.S. » (<http://www.elsevier.com/locate/ansens>) implique l'accord avec les conditions générales d'utilisation (<http://www.numdam.org/conditions>). Toute utilisation commerciale ou impression systématique est constitutive d'une infraction pénale. Toute copie ou impression de ce fichier doit contenir la présente mention de copyright.

NUMDAM

Article numérisé dans le cadre du programme
Numérisation de documents anciens mathématiques
<http://www.numdam.org/>

UNFOLDING CONTRACTING SINGULAR CYCLES

BY M. J. PACIFICO AND A. ROVELLA

ABSTRACT. — We show that if we start with a Morse-Smale vector field and move through a generic one-parameter family of vector fields to a contracting singular cycle and beyond, we reach a region filled up mostly with hyperbolic flows: the Lebesgue measure of parameter values corresponding to non Axiom A flows is zero.

1. Introduction

The objective of this work is to continue the analysis of a new mechanism, the *singular cycles* introduced in [LP], through which a vector field depending on a parameter may evolve, when the parameter varies, from a vector field, exhibiting a simple dynamics into one exhibiting a highly nontrivial behavior. Recall that a singular cycle for a vector field is a finite set of hyperbolic periodic orbits and singularities linked in a cyclic way by orbits in the intersections of the stable and unstable manifolds of the periodic orbits and the singularities. For the present discussion the singularity is unique (a saddle) and its expanding eigenvalue is smaller than the weakest contracting one: we call the singular cycle *contracting*; otherwise the cycle is called *expanding*.

In the present paper we shall, to a large extent, complete the study in [BMLP] by analysing the case of contracting singular cycles, complementary to the expanding ones which were thoroughly studied there. Indeed, in that work it was proved that in the unfolding of a contracting singular cycle an attracting periodic orbit is created. So, it is natural to ask if infinitely many attracting periodic orbits can be created, which would be an obstruction to hyperbolicity. Here, for a large class of contracting singular cycles we show that if an attracting periodic orbit is created then it is unique. Moreover, like in that work, if we start with a simple dynamical system, say a Morse-Smale one, and move through a (generic) one-parameter family of vector fields to a contracting singular cycle and beyond, we reach a region filled up mostly with hyperbolic (Axiom A) flows: the Lebesgue measure of parameter values corresponding to non Axiom A flows (bifurcation values) is zero. This result is sharper than that of the expanding singular cycles considered in [BMLP].

Let us now give the precise statements of our results. Let M be a compact and boundaryless 3-manifold and let \mathcal{X}^r be the Banach space of C^r vector fields on M . If $X \in \mathcal{X}^r$ denote $\Gamma(X)$ its chain recurrent set. We say that $X \in \mathcal{X}^r$ is *simple* when $\Gamma(X)$ is a union of finitely many hyperbolic critical orbits. By a critical orbit we mean an orbit

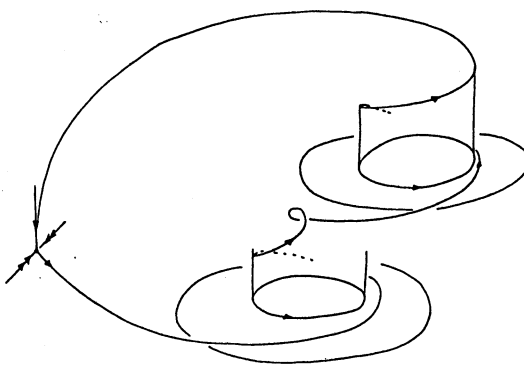

Fig. 1

that is either periodic or singular. It is easy to see that the set S^r of simple C^r vector fields is an open subset of \mathcal{X}^r .

Denote $C^k(I, \mathcal{X}^r)$ the space of families X_μ of C^r vector fields depending on a parameter $\mu \in [-1, 1]$ such that the map $[-1, 1] \ni \mu \rightarrow X_\mu \in \mathcal{X}^r$ is C^k . Endow $C^k(I, \mathcal{X}^r)$ with the C^k topology.

We will consider the families $X_\mu \in C^k(I, \mathcal{X}^k)$ such that $X_{-1} \in S^r$ and there exists $\mu > -1$ so that $X_\mu \notin S^r$. The *crossing value of the parameter* of such a family is the supremum of the μ 's such that $X_\mu \in S^r$ (or, what is the same, the minimum μ such that $X_\mu \notin S^r$). Denote $C_*^k(I, \mathcal{X}^r)$ the set of such families. To simplify the notation we shall add in the definition of $C_*^k(I, \mathcal{X}^r)$ the requirement that the crossing value of the parameter is zero, *i. e.*,

$$X_\mu \in C_*^k(I, \mathcal{X}^r) \Rightarrow \begin{cases} X_\mu \in S^r & \text{if } \mu < 0 \\ X_0 \notin S^r \end{cases}$$

A *cycle* of $X \in \mathcal{X}^r$ is a compact invariant chain recurrent set of X consisting of finitely many hyperbolic periodic orbits and orbits whose α and ω -limit sets are different hyperbolic periodic orbits.

An orbit γ of a vector field X is *nontransversal* if $\alpha(\gamma)$ and $\omega(\gamma)$ are hyperbolic critical orbits and the stable and unstable manifolds of $\alpha(\gamma)$ and $\omega(\gamma)$ intersect non transversally along γ .

Our object of study will be *simple singular cycles* defined as follows: a simple singular cycle of $X \in \mathcal{X}^r$ is a cycle Λ of X satisfying

- Λ contains a unique singularity σ_0
- The eigenvalues of $D_{\sigma_0} X : T_{\sigma_0} M \rightarrow T_{\sigma_0} M$ are real and satisfy $-\lambda_3 < -\lambda_1 < 0 < \lambda_2$
- Λ contains a unique nontransversal orbit γ_0 . Moreover, γ_0 is contained in $W^u(\sigma_0)$ and $\omega(\gamma_0)$ is a periodic orbit σ_1
- For every $p \in \gamma_0$ and every invariant manifold $W(\sigma_0)$ of X , passing through σ_0 and tangent at σ_0 to the space spanned by the eigenvectors associated to $-\lambda_1$ and λ_2 , we

have

$$T_p W(\sigma_0) + T_p W^s(\sigma_1) = T_p M.$$

e) There exists a neighborhood \mathcal{U} of X such that if $Y \in \mathcal{U}$ the continuations $\sigma_i(Y)$, $0 \leq i \leq k$ of the critical orbits σ_i , $0 \leq i \leq k$ of the cycle are well defined and the vector field Y is C^2 -linearizable nearby $\sigma_0(Y)$ and the Poincaré maps of $\sigma_i(Y)$, $1 \leq i \leq k$ are C^2 -linearizable

f) Λ is isolated, *i.e.*, it has an isolating block. Recall that an isolating block of an invariant set Λ of a vector field X is an open set $U \subset M$ such that

$$\Lambda = \bigcap_t X^t(U),$$

where $X^t: M \rightarrow M$ is the flow generated by X .

In [BLMP] the following theorems are proved.

THEOREM I. — *If $r \geq 3$ and $k \geq 1$ there exists an open and dense set \mathcal{A} of $C_*^k(I, \mathbb{R}^r)$ such that if $X_\mu \in \mathcal{A}$ and X_0 has a cycle Λ that contains a singularity, then Λ is a simple singular cycle and $\Gamma(X_0) \setminus \Lambda$ is a finite union of hyperbolic critical orbits.*

THEOREM II. — *Let Λ be a simple singular cycle of $X \in \mathbb{R}^r$ and let U be an isolating block of Λ . Then there exists a neighborhood \mathcal{U} of X and a codimension one submanifold $\mathcal{N} \subset \mathbb{R}^r$ containing X such that*

a) $Y \in \mathcal{U} \cap \mathcal{N} \Rightarrow \Lambda(Y, U) = \bigcap_t Y^t(U)$ is a simple singular cycle topologically equivalent

to Λ .

b) $\mathcal{U} \setminus \mathcal{N}$ has two connected components and one of them, denoted by \mathcal{U}^- is such that $Y \in \mathcal{U}^-$ implies that the chain recurrent set of $Y/\Lambda(Y, U)$ consists of the continuations $\sigma_i(Y)$, $0 \leq i \leq k$ of the critical orbits σ_i , $0 \leq i \leq k$, contained in Λ .

This means that the cycle persists topologically unchanged in $\mathcal{N} \cap \mathcal{U}$ and is broken in \mathcal{U}^- . Denote by \mathcal{U}^+ the other connected component of $\mathcal{U} \setminus \mathcal{N}$. Define \mathcal{U}_H^+ as the set of $Y \in \mathcal{U}^+$ such that the chain recurrent set of $Y/\Lambda(Y, U)$ is $\sigma_0(Y)$ plus a transitive hyperbolic set and \mathcal{U}_H^+ as the set of $Y \in \mathcal{U}^+$ for which the chain recurrent set of $Y/\Lambda(Y, U)$ is the union of $\sigma_0(Y)$, a transitive hyperbolic set and a unique attracting periodic orbit.

The study of $\mathcal{U}^+ \setminus (\mathcal{U}_H^+ \cup \mathcal{U}_H^+)$ depends on whether the eigenvalues $-\lambda_3 < -\lambda_1 < 0 < \lambda_2$ at the singularity $\sigma_0 \in \Lambda$ satisfy $-\lambda_1 + \lambda_2 > 0$ or $-\lambda_1 + \lambda_2 < 0$. In the first case we say that the cycle is *expanding* and in the second that it is *contracting*. In the *expanding* case it was proved in [BMLP] that \mathcal{U}_H^+ is empty and \mathcal{U}_H^+ is dense in \mathcal{U}^+ . Here we shall prove, for a large class of contracting singular cycles, determined by supplementary conditions on the eigenvalues of the singularity, that $\mathcal{U}_H^+ \cup \mathcal{U}_H^+$ is not only dense in \mathcal{U}^+ but in parametrized form it is of total Lebesgue measure. To state precisely our theorem, let $\beta = \lambda_3/\lambda_2$ and $\alpha = \lambda_1/\lambda_2$. We say that the contracting singular cycle Λ is *strongly contracting* if $\beta > \alpha + 2$. We shall prove

THEOREM A. — *If $X_\mu \in \mathcal{A}$ crosses transversally \mathcal{N} at X_0 and X_0 has a strongly contracting singular cycle Λ_0 having an isolating block U and a unique closed orbit then there exists $t > 0$ so that $m\{0 \leq \mu \leq t; X_\mu \in \mathcal{W}^+ \setminus (\mathcal{W}_H^+ \cup \mathcal{W}_H^+)\} = 0$, where m stands for Lebesgue measure.*

The $\beta > \alpha + 2$ condition is necessary to grant the C^3 differentiability of the stable foliation constructed for the first return map associated to Λ_0 . So the dynamics in the space of leaves of this foliation is given by a C^3 mapping which also has negative Schwarzian derivative. The technique for the proof of theorem A exploits this fact and also a monotonicity property of such maps. We believe that our result should be through even if the condition $\beta > \alpha + 2$ is removed. However, the proof will possibly be more technically involved.

2. Proof of Theorem A

Let $X_\mu \in \mathcal{A}$ be as in the statement of theorem A and σ_1 the unique closed orbit in Λ_0 .

Let S be a cross section to the flow of X_0 at $q \in \sigma_1$ parametrized by $\{(x, y); |x|, |y| \leq 1\}$ and satisfying $W^s(\sigma_1) \cong \{(x, 0), |x| \leq 1\}$ and $W^u(\sigma_1) \cong \{(0, y), |y| \leq 1\}$.

We call a closed subset $C \subset S$ a horizontal strip if it is bounded (in S) by two disjoint continuous curves connecting the vertical sides of S , $\{(-1, y), |y| \leq 1\}$ and $\{(1, y), |y| \leq 1\}$.

Let p_0 be the first intersection of γ with S . Then $p_0 = (x_0, 0)$ and we assume $x_0 > 0$. Since $W^u(\sigma_1)$ intersects $W^s(\sigma_0)$ and $\gamma \subset W^u(\sigma_0)$ has σ_1 as ω -limit set, a first return map F_0 is defined on a subset of S . Moreover, if $q_0 = (0, y_0) \in S$ is such that its ω -limit set is σ_0 then there exists a horizontal strip $R_0 \ni q_0$ so that F_0 is defined on R_0 .

Clearly F_0 is also defined in a small horizontal strip R containing $W^s(\sigma_1) \cap S$ and its restriction to R coincides with the Poincaré map associated to σ_1 . See Figure 2.

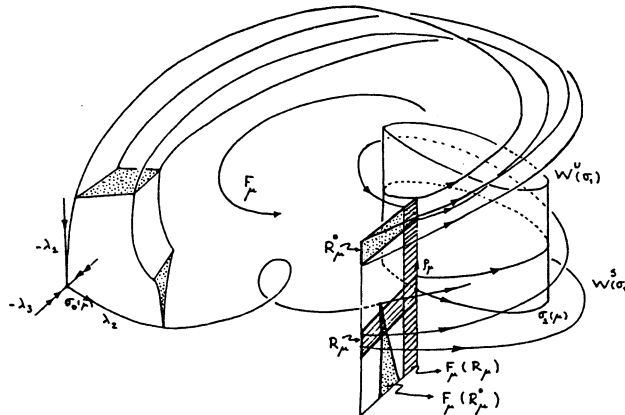

Fig. 2

If $\mu > 0$ is sufficiently small then S is still a cross section for X_μ at $\sigma_1(\mu)$ and $W^u(\sigma_0(\mu))$ intersects S at $p_\mu = (x_\mu, y_\mu)$. Here $\sigma_i(\mu)$, $i=0, 1$, are the continuations of σ_0, σ_1 . As before a first return map F_μ , $\mu > 0$, is defined on $R_{0,\mu} \cup R_\mu$, and the restriction of F_μ to R_μ coincides with the Poincaré map associated to $\sigma_1(\mu)$. Observe that F_μ looks like a pinched horseshoe.

Since $\beta > \alpha + 2$, following the techniques in [HPS] as in [BMLP] and [R] one proves the following lemma:

LEMMA. — For every $\mu \geq 0$ sufficiently small there exists an invariant C^3 stable foliation \mathcal{F}_μ^s for F_μ , depending C^1 on μ .

Let $\{f_\mu, \mu \geq 0\}$ be the family of maps of the interval induced by $\{\mathcal{F}_\mu^s, \mu \geq 0\}$. Since \mathcal{F}_μ^s is C^3 , each f_μ is also C^3 and it depends C^1 on μ . We can suppose that f_μ is defined on $[0, 1]$ and the point $x=1$ is the projection along \mathcal{F}_μ^s of the leaf containing $(0, y_0)$. We can also parametrize $\{f_\mu, \mu \geq 0\}$ in such way that $f_\mu(1) = \mu$. So for sufficiently small μ there exists a point $0 < a_\mu < 1$ such that $f_\mu(a_\mu) = 0$. Moreover, if f'_μ is the derivative of f_μ with respect to x , each f'_μ has a zero of order $\alpha_\mu - 1$ at $x=1$ and the general form of f_μ is

$$f_\mu(x) = \begin{cases} \rho_\mu \cdot x, & x \in [0, \rho_\mu^{-1}] \\ \mu - K_\mu(x) \cdot (1-x)^{\alpha_\mu}, & x \in [a_\mu, 1] \end{cases}$$

where $K_\mu(1) > 0$ and ρ_μ is the expanding eigenvalue of the Poincaré map associated to $\sigma_1(\mu)$. Since f_μ is C^3 so do K_μ .

The following properties of f_μ can be easily verified.

There exists $\bar{\mu} > 0$ such that for every $\mu \in [0, \bar{\mu}]$ we have:

- (i) $\partial/\partial\mu f_\mu(x) > 1/2$ for $x \in [a_\mu, 1]$
- (ii) $f'_\mu(x) > 0$ for $x \neq 1$
- (iii) $f''_\mu(x) < 0$ in $[a_\mu, 1]$
- (iv) $S f_\mu(x) < 0$ in $[a_\mu, 1]$, where $S f_\mu$ is the Schwarzian derivative of f_μ .

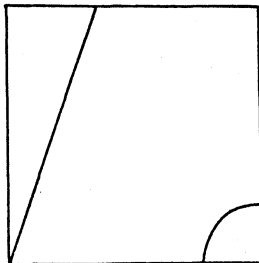

Fig. 3

Without loss of generality we will assume $\rho_\mu = \rho$ for every $\mu \in [0, \bar{\mu}]$. Let $I_\mu^{(1)} = [0, \rho^{-1}]$, $I_\mu = (\rho^{-1}, a_\mu)$, $I_\mu^{(2)} = [a_\mu, 1]$ and $\Lambda_\mu = \{x; f_\mu^n(x) \notin I_\mu \text{ for every } n \geq 0\}$. Call $\bar{\Lambda} = \{\mu; 1 \notin \Lambda_\mu\}$ and $H = \{\mu; f_\mu \text{ is hyperbolic}\}$. Recall that f_μ is hyperbolic if it has a

finite number of attracting periodic points and the complement of their basins intersected with Λ_μ is hyperbolic expansive, that is, for all x in this set

$$(f_\mu^n)'(x) \geq C \cdot \lambda^n,$$

for some constants $C > 0$ and $\lambda > 1$.

We now claim

- (i) if $\mu \in \tilde{\Lambda}$ then $\mu \in H$
- (ii) if f_μ has a hyperbolic attracting periodic orbit contained in Λ_μ then $\mu \in H$.

To prove this claim first observe that if γ is an attracting periodic orbit for f_μ of period n and $B(\gamma)$ is its basin of attraction then $S(f_\mu^n/B(\gamma)) < 0$ because at least one point of γ belongs to $I_\mu^{(2)}$. Otherwise γ would not be an attracting periodic orbit. So Singer's theorem [S] can be applied to obtain that there exists at most one attracting periodic orbit and it has the critical point in its basin. To conclude we proceed as follows. In the first case we call $K_\mu = \Lambda_\mu$ and in the second we define $K_\mu = \Lambda_\mu \setminus B(\gamma_\mu)$, where γ_μ is the attracting periodic orbit of f_μ . In both cases K_μ is an invariant compact set without critical orbits, nonhyperbolic periodic orbits and attracting periodic orbits. Since $S(f_\mu) < 0$ we obtain that K_μ is a hyperbolic set, proving that f_μ is hyperbolic.

Denote m the Lebesgue measure. It is not difficult to see that theorem A is a consequence of the following theorem

THEOREM. — *There exists $\bar{\mu} > 0$ such that $m(H \cap [0, \bar{\mu}]) = \bar{\mu}$.*

To obtain this result we will prove that there exists $\bar{\mu} > 0$ so that for every $\mu_0 \in [0, \bar{\mu}]$,

$$\lim_{\varepsilon \rightarrow 0} \frac{m(H^c \cap [\mu_0 - \varepsilon, \mu_0 + \varepsilon])}{2\varepsilon} < 1,$$

where H^c is the complement of H in \mathbf{R} . So H^c has no full density point at $[0, \bar{\mu}]$ and thus it has measure zero in $[0, \bar{\mu}]$, concluding the proof of the theorem.

Suppose that $f_\mu^j(1) \notin I_\mu$ for $0 \leq j \leq N$; in this case, define the sequence $\xi_N(\mu)$ by:

$$0 \leq j \leq N, \quad \xi_N(\mu)(j) = \begin{cases} 1 & \text{if } f_\mu^j(1) \in I_\mu^{(1)} \\ 2 & \text{if } f_\mu^j(1) \in I_\mu^{(2)} \end{cases}$$

LEMMA 1. — *Suppose that $\xi_N(\mu)$ is defined and constant in an interval $[\mu_0, \mu_1]$ for $\mu_1 < \bar{\mu}$, $\bar{\mu}$ small enough. Then $\chi_n(\mu) \leq 2\chi_n(\mu_0)$ for every $\mu \in (\mu_0, \mu_1]$, where $\chi_n(\mu) = \partial/\partial\mu f_\mu^n(1)$.*

Proof. — Firstly, observe that $\chi_n(\mu) > 1/2$ for every $n \leq N$, and μ . In fact,

$$\begin{aligned} \chi_{n+1}(\mu) &= \rho\chi_n(\mu) && \text{for } f_\mu^n(1) \in I_\mu^{(1)} \\ \chi_{n+1}(\mu) &= \chi_n(\mu)f'_\mu(f_\mu^n(1)) + \frac{\partial}{\partial\mu} f_\mu(x)|_{x=f_\mu^n(1)} && \text{for } f_\mu^n(1) \in I_\mu^{(2)} \end{aligned}$$

So, using (i) and (ii) the assertion follows by induction.

Therefore, the hypothesis of the lemma implies that

$$f_\mu^n(1) - f_{\mu_0}^n(1) \geq \frac{1}{2}(\mu - \mu_0) \quad \text{for } \mu \in [\mu_0, \mu_1]$$

and $n \leq N$.

Now we claim that:

$$(1) \quad f'_\mu(f_\mu^n(1)) \leq f'_{\mu_0}(f_{\mu_0}^n(1)) \quad \text{for } \mu_0 \leq \mu \leq \mu_1.$$

Let $F(\mu, x) = f'_\mu(x)$. To have (1) it is enough to prove that $DF_{(\mu, x)}(v) < 0$ for every vector $v = (v_1, v_2)$ such that $v_1 > 0$ and $v_2 > 1/2 v_1$. A simple calculation shows that, for $x \in I_\mu^{(2)}$

$$DF_{(\mu, x)}(v) = (1-x)^{\alpha-1} L(\mu, x)v_1 - (1-x)^{\alpha-2} M(\mu, x)v_2$$

where L and M are C^1 positive and limited functions. So, as $(1-x)^{\alpha-2}$ is greater than $(1-x)^{\alpha-1}$ if x is close to 1, we can make $\bar{\mu}$ smaller the obtain the claim.

Now we prove the lemma by induction:

It is obviously true for $n=1$ if $\bar{\mu}$ is small enough. If $n+1 \leq N$ we have

$$\frac{\chi_{n+1}(\mu)}{\chi_{n+1}(\mu_0)} = \frac{\chi_n(\mu)}{\chi_n(\mu_0)} \quad \text{if } f_\mu^n(1) \in I_\mu^{(1)}.$$

If $f_\mu^n(1) \in I_\mu^{(2)}$, then:

$$\frac{\chi_{n+1}(\mu)}{\chi_{n+1}(\mu_0)} = \frac{\chi_n(\mu)f'_\mu(f_\mu^n(1)) + \partial/\partial\mu f_\mu(x)|_{x=f_\mu^n(1)}}{\chi_n(\mu_0)f'_{\mu_0}(f_{\mu_0}^n(1)) + \partial/\partial\mu f_\mu(x)|_{x=f_{\mu_0}^n(1), \mu=\mu_0}}$$

Using the claim and the induction hypothesis together with (1) it follows that, for $\bar{\mu}$ small enough,

$$\chi_{n+1}(\mu) \leq 2\chi_n(\mu_0)f'_{\mu_0}(f_{\mu_0}^n(1)) + 2\frac{\partial}{\partial\mu} f_\mu(x)|_{x=f_{\mu_0}^n(1), \mu=\mu_0}$$

This implies that $\chi_{n+1}(\mu)/\chi_{n+1}(\mu_0) \leq 2$.

Now denote by $R_k(\mu)$ the interval contained in $I_\mu^{(1)}$ such that

- $f_\mu^j(R_k(\mu)) \subset I_\mu^{(1)}$ for every $0 \leq j < k$
- $f_\mu^k(R_k(\mu)) = I_\mu^{(2)}$

Observe that $R_k(\mu) = [\rho^{-k} a_\mu, \rho^{-k}]$.

Denote by $B_k(\mu)$ the interval in $I_\mu^{(1)}$ such that

- $f_\mu^j(B_k(\mu)) \subset I_\mu^{(1)}$ for every $0 \leq j < k$
- $f_\mu^k(B_k(\mu)) = I_\mu$

So $B_k(\mu) = (\rho^{-k-1}, \rho^{-k} a_\mu)$

Observe that $\Lambda_\mu \subset \bigcup_{n \geq 1} R_n(\mu)$.

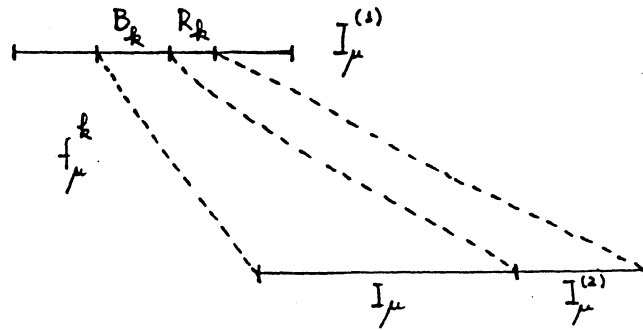

Fig. 4

LEMMA 2. — Suppose that ξ_{N-1} is constant in $[\mu_0, \mu_1]$, and that the interval $[f_{\mu_0}^N(1), f_{\mu_1}^N(1)]$ contains some $B_k(\mu_1)$. Then there exists $\mu_2 \in (\mu_0, \mu_1]$ such that:

$$\frac{m(H^c \cap [\mu_0, \mu_2])}{\mu_2 - \mu_0} \leq \frac{1}{3}.$$

Proof. — As $\chi_n(\mu) > 0$ in $[\mu_0, \mu_1]$, the lemma is obvious if $f_{\mu_0}^N(1) \in \bigcup_{j \geq 1} B_j(\mu_0)$. So suppose that $f_{\mu_0}^N(1) \in R_{k+1}(\mu_0)$.

Let $\mu_2 \in (\mu_0, \mu_1)$ be such that $f_{\mu_2}^N(1) = \rho^{-k} a_{\mu_2}$, that is, $f_{\mu_2}^N(1)$ is the right extreme point of $B_k(\mu_2)$. Such μ_2 exists because $f_{\mu_1}^N(1) \geq \rho^{-k} a_{\mu_1}$ and $f_{\mu_0}^N(1) < \rho^{-k-1} < \rho^{-k} a_{\mu}$ for every $\mu \in [\mu_0, \mu_1]$. Note also that there exists exactly one point $\tilde{\mu}$ such that $f_{\tilde{\mu}}^N(1) = \rho^{-k-1}$.

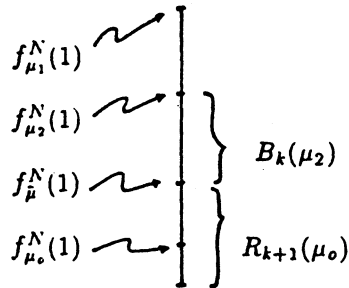

Fig. 5

Observe that, by Lemma 1, we have:

$$(2) \quad \rho^{-k} a_{\mu_2} - \rho^{-k-1} = l(B_k(\mu_2)) = f_{\mu_2}^N(1) - f_{\tilde{\mu}}^N(1) = \int_{\tilde{\mu}}^{\mu_2} \chi_n d\mu \leq \int_{\tilde{\mu}}^{\mu_2} 2\chi_n(\tilde{\mu}) = 2\chi_n(\tilde{\mu})(\mu_2 - \tilde{\mu})$$

$$\begin{aligned}
 (3) \quad \rho^{-k-1} - \rho^{-k-1} a_{\mu_0} = l(\mathbf{R}_{k+1}(\mu_0)) &\geq f_{\tilde{\mu}}^N(1) - f_{\mu_0}^N(1) = \int_{\mu_0}^{\tilde{\mu}} \chi_n d\mu \\
 &\geq \int_{\mu_0}^{\tilde{\mu}} \frac{1}{2} \chi_n(\tilde{\mu}) d\mu = \frac{1}{2} \chi_n(\tilde{\mu}) (\tilde{\mu} - \mu_0).
 \end{aligned}$$

As we observed above, $H^c \cap [\mu_0, \mu_2] \subset [\mu_0, \tilde{\mu}]$. So,

$$\frac{m(H^c \cap [\mu_0, \mu_2])}{\mu_2 - \mu_0} \leq \frac{\tilde{\mu} - \mu_0}{\mu_2 - \mu_0}.$$

Now, using (2) and (3), it follows that:

$$\frac{\tilde{\mu} - \mu_0}{\mu_2 - \tilde{\mu}} \leq \frac{2(\rho^{-k-1} - \rho^{-k-1} a_{\mu_0})}{1/2(\rho^{-k} a_{\mu_2} - \rho^{-k-1})} = \frac{4}{\rho} \frac{1 - a_{\mu_0}}{a_{\mu_2} - \rho^{-1}}.$$

This can be taken smaller than 1/2, because $(1 - a_{\mu_0}) \rightarrow 0$ as $\mu_0 \rightarrow 0$.

Therefore,

$$\frac{\tilde{\mu} - \mu_0}{\mu_2 - \mu_0} = \frac{\tilde{\mu} - \mu_0}{\mu_2 - \tilde{\mu} + \tilde{\mu} - \mu_0} \leq \frac{\tilde{\mu} - \mu_0}{2(\tilde{\mu} - \mu_0) + (\tilde{\mu} - \mu_0)} = \frac{1}{3}.$$

COROLLARY. — Given $\mu_0 \notin \tilde{\Lambda}$, suppose that there exists no interval $[\mu_0, \mu_1]$ such that $\xi_n(\mu)$ is constant in $[\mu_0, \mu_1]$ for all n . Then μ_0 is not a full density point of H^c .

Proof. — There are two possibilities: either μ_0 is accumulated by parameters μ_1 in the hypothesis of the lemma, or it is not. In the second case, the hypothesis of the corollary forces every $\tilde{\mu} > \mu_0$ close to μ_0 to satisfy that there exists an integer $m > 0$ such that $f_{\tilde{\mu}}^m(1) \in B_k(\tilde{\mu})$. This $\tilde{\mu} \in H$. In the first case the corollary follows immediately from the lemma.

Proof of the Theorem. — As we said above, it is enough to prove that no $\mu_0 \in [0, \bar{\mu}]$ is a full density point of H^c .

Firstly, observe that if the critical point is f_{μ_0} -recurrent, but not periodic, then this μ_0 falls into the hypothesis of the corollary above.

Suppose now that the critical point is periodic by f_{μ_0} . The derivative of $\mu \rightarrow f_{\mu}^k(x)$ is ≥ 0 for all x , so there exists an interval (μ', μ_0) such that f_{μ} has an attracting periodic orbit; now $\mu \in H$ for all $\mu \in (\mu', \mu_0)$.

Then the only case that remains is when 1 is not f_{μ_0} -recurrent, and $\mu_0 \notin \tilde{\Lambda}$. Suppose that the hypothesis of the corollary is not satisfied by f_{μ_0} , that is, there exists $\mu_1 > \mu_0$ such that ξ_n is defined and constant in $[\mu_0, \mu_1]$ for every $n > 0$ and let's find a contradiction.

The point 1 cannot be f_{μ} -recurrent for $\mu \in [\mu_0, \mu_1]$; this would imply that ξ_n is not always defined in $[\mu_0, \mu_1]$. If f_{μ} has an attracting periodic orbit for some $\mu \in (\mu_0, \mu_1)$, then the same occurs in the interval (μ, μ_1) ; this follows from the claim in lemma 1. So we can assume that there are no attracting periodic orbit for each f_{μ} , $\mu \in (\mu_0, \mu_1)$, and that 1 is not f_{μ} -recurrent. So $\omega_{f_{\mu}}(1)$, the ω -limit set of 1 by f_{μ} , is hyperbolic for

$\mu \in [\mu_0, \mu_1]$. As

$$\begin{aligned} \frac{\chi_{n+1}(\mu_1)}{(f_{\mu_1}^n)'(\mu_1)} &= \frac{\chi_n(\mu_1) \cdot f'_{\mu_1}(f_{\mu_1}^n(1)) + \partial/\partial\mu f_{\mu_1}(x)|_{x=f_{\mu_1}^n(1)}}{f'_{\mu_1}(f_{\mu_1}^n(1)) \cdot (f_{\mu_1}^{n-1})'(\mu_1)} \\ &= \frac{\chi_n(\mu_1)}{(f_{\mu_1}^{n-1})'(\mu_1)} + \frac{\partial/\partial\mu f_{\mu_1}(x)|_{x=f_{\mu_1}^n(1)}}{(f_{\mu_1}^n)'(\mu_1)} \end{aligned}$$

and $(f_{\mu_1}^n)'(\mu_1)$ is exponentially increasing there exists a constant C independent of n such that

$$\left| \frac{\chi_{n+1}(\mu_1)}{(f_{\mu_1}^n)'(\mu_1)} \right| \in (C^{-1}, C).$$

So $\chi_{n+1}(\mu)$ is exponentially increasing. By lemma 1, the same occurs for every $\chi_{n+1}(\mu)$, $\mu \in [\mu_0, \mu_1]$, and with the same rates. This is impossible, because we have supposed that in $[\mu_0, \mu_1]$ the interval $[f_{\mu_0}^n(1), f_{\mu_1}^n(1)]$ has limited length. The theorem is proved.

REFERENCES

- [BMLP] R. BAMÓN, R. LABARCA, R. MAÑÉ and M. J. PACIFICO, *The Explosion of Singular Cycles* (to appear at *Publ. Math. IHES*).
- [HPS] M. HIRSCH, C. PUGH and M. SHUB, *Invariant Manifolds (Lecture Notes in Mathematics, Vol. 583, Springer-Verlag, 1977)*.
- [LP] R. LABARCA and M. J. PACIFICO, *Stability of Singular Horseshoes (Topology, Vol. 25, n° 3, 1986)*.
- [R] A. ROVELLA, *The Dynamics of Perturbations of the Contracting Lorenz Attractor* (Thesis, IMPA and to appear at *Bol. Soc. Bras. Mat.*).
- [S] S. SINGER, *Stable Orbits and Bifurcations of Maps of the Interval (SIAM, J. Appl. Math., Vol. 35, 1978)*.

(Manuscript received February 28, 1992;
revised September 11, 1992.)

M. J. PACIFICO and A. ROVELLA,
Departamento de Matemática Aplicada,
Instituto de Matemática, UFRJ,
C.P. 68530, CEP 21910,
Rio de Janeiro, RJ, Brasil.