



## **COPYRIGHT AND USE OF THIS THESIS**

This thesis must be used in accordance with the provisions of the Copyright Act 1968.

Reproduction of material protected by copyright may be an infringement of copyright and copyright owners may be entitled to take legal action against persons who infringe their copyright.

Section 51 (2) of the Copyright Act permits an authorized officer of a university library or archives to provide a copy (by communication or otherwise) of an unpublished thesis kept in the library or archives, to a person who satisfies the authorized officer that he or she requires the reproduction for the purposes of research or study.

The Copyright Act grants the creator of a work a number of moral rights, specifically the right of attribution, the right against false attribution and the right of integrity.

You may infringe the author's moral rights if you:

- fail to acknowledge the author of this thesis if you quote sections from the work
- attribute this thesis to another author
- subject this thesis to derogatory treatment which may prejudice the author's reputation

For further information contact the University's Copyright Service.

**[sydney.edu.au/copyright](http://sydney.edu.au/copyright)**

**PRODUCTION OF LOVASTATIN, (+)-GEODIN  
AND SULOCHRIN BY *ASPERGILLUS TERREUS*  
ATCC 20542 USING PURE AND CRUDE  
GLYCEROL**

By

**Muhamad Hafiz Abd Rahim**

A thesis submitted in fulfilment of the requirements for the degree of

**Doctor of Philosophy**

**SCHOOL OF CHEMICAL & BIOMOLECULAR ENGINEERING**

**THE UNIVERSITY OF SYDNEY**



THE UNIVERSITY OF  
**SYDNEY**

**SEPTEMBER 2015**

## **DECLARATION**

I declare that the entire content of this thesis is, to the best of my knowledge and belief, original, unless specifically stated in the text, and has not been submitted for a degree at any other university.

Muhamad Hafiz Abd Rahim

## ABSTRACT

*A. terreus* ATCC 20542 is a prolific fungi strain known for its ability to produce lovastatin, a potent cholesterol-lowering drug. Lovastatin is synthesised via type I polyketide pathway (PKS), a common pathway used to produce secondary metabolites in microorganisms. This pathway is also responsible for the production of two co-metabolites of lovastatin, namely (+)-geodin and sulochrin. This study aimed to characterise the production of lovastatin and its co-metabolites, sulochrin and (+)-geodin by *A. terreus*, and to investigate the relationship between lovastatin, sulochrin and (+)-geodin production using bio-waste crude glycerol (CG) as the substrate.

The first part of this study investigated the effects of the major components of culture medium for the production of lovastatin, (+)-geodin and sulochrin, and pellet morphology. This investigation revealed that the types of carbon source have a major influence on lovastatin production, but not (+)-geodin and sulochrin. By contrast, the types of nitrogen source mainly influence (+)-geodin and sulochrin production. Of note, reasonable lovastatin production (25.68 mg/L), with high production of (+)-geodin (9.00 mg/L) and sulochrin (22.35 mg/L) can be achieved using glycerol as the carbon source, and yeast extract as the nitrogen source. Further, culture with glycerol produced pellets with hairy morphology, which are optimal for the production of lovastatin, (+)-geodin and sulochrin. These results provide a basis for optimum culture conditions for subsequent experiments to study the production of metabolites by *A. terreus*.

The second part of the study investigated the potential of crude glycerol (CG), a common bio-waste product from biodiesel industry, as the substrate for *A. terreus* cultivation and the production of metabolites of interest. At 30 g/L of CG, the

production of (+)-geodin (13.14 mg/L) and sulochrin (14.79 mg/L) increased almost 2-fold, with a significant inhibition of lovastatin production (~35% reduction) when compared to pure glycerol (PG). The major contaminants from CG were then identified, and their effects on *A. terreus*' growth and metabolite production were determined to further explain these observations. These studies show that the presence of contaminants in CG including saturated fatty acids (up to 48% reduction) and soap (up to 90% reduction) could contribute to the inhibitory effect of CG on lovastatin production, with no inhibition was observed on (+)-geodin and sulochrin production. Conversely, some contaminants, including double-bonded fatty acid such as oleic acid, methanol (MeOH) and salt (NaCl) could enhance lovastatin production up to 72%, with varying effects on (+)-geodin and sulochrin production. Partial purification of CG using solvent and activated carbon (AC) resulted in an improved yield of all three metabolites. This investigation revealed that CG can potentially be used to cultivate *A. terreus*, provided that sufficient purification is conducted on CG.

Elicitor refers to a substance that provokes the microorganism's defense system. The third part of this study investigated the effects of selected 'elicitors' on the production of lovastatin, (+)-geodin's and lovastatin, and to elucidate the relationship between these three metabolites, if any. CG, which was subjected to partial purification by AC, was used for this part of the study, as the product purity was comparable to pure glycerol. In this study, the elicitors of choice were chemical elicitors such as sodium alginate, cholesterol, malonic acid, and physical elicitors such as shear force and viscosity. It was found that chemical elicitor stimulated the production of both lovastatin and sulochrin, with a lesser degree of stimulation on (+)-geodin's production. On the other hand, (+)-geodin's production was suppressed in the presence of high viscosity (<13 mg/L), whilst its production was significantly stimulated by high shear

force condition (>500 mg/L). These observations indicate that lovastatin and sulochrin may play a role in *A. terreus*' defense mechanism. Conversely, (+)-geodin may be important for fungal pellet integrity or immediate response to injury, as physical force greatly enhanced its production.

In conclusion, CG is a promising alternative substrate for metabolite production by *A. terreus*, provided that sufficient purification and culture conditions are applied. This study, however, demonstrates no apparent relationship between the production of lovastatin, (+)-geodin and sulochrin by *A. terreus* using glycerol or CG as the substrate.

Keywords: *Aspergillus terreus*; lovastatin; (+)-geodin; sulochrin; optimisation; crude glycerol; culture media;

## **ACKNOWLEDGEMENT**

I would like to thank several people for making this thesis a possibility:

To my supervisor, Associate Professor Dr Ali Abbas, for his guidance and direction throughout my Ph.D years.

To my co-supervisor, Dr Alejandro Montoya, for his tireless effort in helping me with most of my thesis writing.

To my lab mates, Fareed Sairi, Hanan Hasan, Mouna Hamad, Sophie Solchenbach and Bernadeth Antonio, thank you for your continual support and encouragement throughout all these years.

Ministry of Education Malaysia and University of Sydney for the financial assistance.

The postgrads and staff members of School of Chemical & Biomolecular Engineering, University of Sydney.

Last but not least, to my wife Hanis Harith, for her continuous support throughout my Ph.D years.

## TABLE OF CONTENT

DECLARATION .....	i
ABSTRACT .....	ii
ACKNOWLEDGEMENT .....	v
TABLE OF CONTENT .....	vi
FIGURE LIST .....	ix
NOMENCLATURE.....	xv
Chapter 1 – Introduction .....	1
1.0 <i>Aspergillus terreus</i> ATCC 20542.....	1
1.1 Lovastatin, a cholesterol lowering drug produced by <i>Aspergillus terreus</i> ATCC 20542 .....	4
1.1.2 Biosynthesis of lovastatin in fungus .....	11
1.2 The factors that influence lovastatin production by <i>Aspergillus terreus</i> .....	14
1.2.1 Dissolved gas and aeration rate .....	14
1.2.2 The pH of the culture media .....	15
1.2.3 Fungal morphology.....	16
1.2.4 Culture media.....	17
1.3 (+)-geodin and sulochrin in <i>Aspergillus terreus</i> .....	21
1.3.1 (+)-geodin .....	21
1.3.2 Sulochrin.....	24
1.4 Summary of literature review findings, knowledge gap, and proposed investigation .....	25
1.6 General and specific objectives of thesis .....	27
Chapter 2 - Materials, methods and optimisation .....	28
2.1 Description of crude glycerol used in the study .....	28
2.2 Pre-treatments of crude glycerol .....	30
2.3 Culture conditions .....	31
2.3.1 Shear pressure study .....	32
2.3.2 Bacterial-induced elicitation study .....	32
2.4 Fungal biomass dry weight determination .....	33
2.5 Bioreactor study .....	33
2.5.1 High-performance liquid chromatography (HPLC) .....	36



2.5.2 Glycerol calorimetric detection .....	41
2.5.3 Inductively coupled plasma mass spectrometry (ICP) .....	42
2.5.4 Carbohydrate determination .....	42
2.6 Characterisation of metabolic expression profiles using RT-PCR.....	43
2.6.1 Isolation of total cellular RNA.....	43
2.6.2 Synthesis of complementary DNA (cDNA) from RNA.....	44
2.6.3 Real-time polymerase chain reaction (RT-PCR) for quantification of <i>lovB</i> levels .....	45
2.7 Microscopy .....	48
2.8 Statistical analysis .....	49
Chapter 3 - Optimisation of media condition.....	50
3.0 Introduction .....	50
3.1 The effect of salts interactions on the production of lovastatin.....	52
3.2 Nitrogen sources.....	55
3.3 Pre-culture .....	58
3.4 Carbon source.....	64
3.4.1 The relationship between lovastatin, biomass and morphology production of <i>A. terreus</i> under different carbohydrate treatments .....	64
3.4.3 (+)-geodin and sulochrin production .....	80
3.5 Conclusion.....	84
Chapter 4 - Cultivation of <i>A. terreus</i> in crude glycerol.....	85
4.0 Introduction .....	85
4.1 Growth, glycerol consumption and metabolite production .....	88
4.2 Effect of impurities.....	95
4.2.1 Methanol improved lovastatin production but suppress (+)-geodin and sulochrin production .....	95
4.2.2 Sodium chloride induced the production of lovastatin, (+)-geodin and sulochrin.....	99
4.2.3 Effect of fatty acids on metabolite production by <i>A. terreus</i> .....	103
4.3 Metabolite production in bioreactor .....	108
4.4 Pre-treatments strategy to improve Crude Glycerol utilisation by <i>A. terreus</i> .....	112
4.4.1 Comparison between the growth, substrate consumption and metabolite production using crude, pure and non-polar solvent pre-treated glycerol .....	114
4.4.2 The efficiency of non-liquid pre-treatment technique of crude glycerol on substrate consumption, growth and lovastatin production.....	119

4.5 Conclusion.....	123
Chapter 5 - Enhancement of metabolite production in <i>A. terreus</i> by chemical, biological and natural factors .....	124
5.0 Introduction .....	124
5.1 Elicitors .....	130
5.1.1 Sodium alginate improved lovastatin early in cultivation and induced unique pattern of octaketide metabolite production .....	130
5.1.2 Cholesterol induces metabolite production by improving the overall growth rather than inciting defense mechanism of <i>Aspergillus terreus</i> .....	141
5.2 Other stimulating factors of <i>Aspergillus terreus</i> .....	145
5.2.1 Malonic acid inhibits <i>A. terreus</i> growth and metabolite production only during early stage of growth .....	145
5.2.2 Fungal pellet structure and integrity are related to (+)-geodin's production	150
Chapter 6: Final discussion and future direction .....	155
6.0 Final discussion .....	155
6.1 Future direction .....	158
References .....	161
Appendices.....	178

## **FIGURE LIST**

Figure 1.1: **The photographs of *A. terreus***

Figure 1.2: **The micrograph of blue-green mold *Penicillium citrinum***

Figure 1.3: **The discovery, development and history of statins**

Figure 1.4: **The structural similarity of four different statins in comparison to mevalonate, a HMG-CoA intermediate**

Figure 1.5: **The competitive inhibition by lovastatin on HMG-CoA reductase**

Figure 1.6: **Biosynthesis of lovastatin in *Aspergillus terreus* in their acidic form**

Figure 1.7: **Organization of selected fungal PKS gene clusters in lovastatin biosynthesis**

Table 1.1: **The use of carbon and nitrogen sources for lovastatin production**

Figure 1.8: **The biosynthesis of lovastatin, (+)-geodin and sulochrin**

Figure 2.1: **The schematics/design of signal processing in bioreactor**

Figure 2.2: **The setup of the bioreactor for *A. terreus***

Figure 2.3: **The standard curves of three metabolites produced by *A. terreus***

Figure 2.4: **The peaks of lovastatin, (+)-geodin and sulochrin in HPLC chromatogram**

Table 2.1: **The combination of sample and reagents for the synthesis of cDNA**

**Table 2.2: The amount of each reagent used in RT-PCR**

**Table 3.1: Optimisation experiment of salt content in the media**

**Table 3.2: The design (3-levels factorial) of three chosen salts ( $\text{KH}_2\text{PO}_4$ ,  $\text{MgSO}_4 \cdot 7\text{H}_2\text{O}$  and  $\text{NaCl}$ ) and the response (lovastatin production)**

**Figure 3.1: Lovastatin, (+)-geodin, and sulochrin production over the period of 12 days**

**Table 3.3: The effect of nitrogen source (yeast extract) concentration on the growth, metabolite production and morphology of *A. terreus***

**Figure 3.2: The scanning microscope image of *A. terreus* spores under 5000 times magnification**

**Figure 3.3: The investigation of spore factors on the production of metabolites by *A. terreus***

**Figure 3.4: An example of scanning electron microscope image of *A. terreus* spore taken from the spore stock**

**Figure 3.5: Different structures of monosaccharides and disaccharides used in this study**

**Figure 3.6: The electron microscopy images of spore cultivated in different types of carbohydrate after 24 hours**

**Figure 3.7: Three major pellet morphologies observed during fermentation of *A. terreus* at day 6**

**Table 3.4: The yield coefficients, final biomass ( $X_{FINAL}$ ) and final diameter ( $\emptyset_{FINAL}$ ) of *A. terreus* in basic media for a period of 6 days**

**Figure 3.8: Lovastatin and biomass production under different carbohydrate treatment over the span of 6 days using 4 g/L yeast extract as a nitrogen source**

**Figure 3.9: The consumption and consumption rate of carbon sources by *A. terreus***

**Table 3.5: The hypotheses involving the effect of different types of carbohydrate as carbon sources on the production of lovastatin by *A. terreus*.**

**Table 3.6: An example of the lovastatin yield (mg/g) obtained using different media composition**

**Figure 3.10: The metabolite production pathway by *A. terreus* ATCC 20542**

**Figure 3.11: Possible catabolism pathways of *A. terreus* starting from several different carbon sources**

**Figure 3.12: The relative mRNA expression of eight carbohydrates using *lovB* as gene of interest**

**Figure 3.13: Sulochrin and (+)-geodin production under different carbohydrates over the span of 6 days in a basic medium with 4 g/L of yeast extract as nitrogen source**

**Table 4.1: Chemical composition and experimental design of impurities used in this study**

**Figure 4.1: The biomass growth curve of *A. terreus* under the presence of different concentrations of CG and PG**

**Figure 4.2: Effect of different concentrations of PG and CG on glycerol consumption by *A. terreus* in 50 mL shake flask experiment**

**Figure 4.3: Time course of (A) lovastatin, (B) (+)-geodin and (C) sulochrin production by *A. terreus* in shake flask experiment using different concentration of PG and CG**

**Figure 4.4: Effect of methanol (MeOH) addition on (A) lovastatin production, (B) (+)-geodin production and (C) sulochrin production by *A. terreus* in shake flask experiment**

**Table 4.2: Growth parameters of fungus in shake flask after 6 days of cultivation of *A. terreus* in the presence of different initial concentrations of methanol (MeOH).**

**Figure 4.5: Effect of NaCl addition on the metabolite production of *A. terreus***

**Table 4.3: The effect of NaCl on biomass concentration and glycerol consumption rate in shake flask experiment at 6 days.**

**Table 4.4: The biomass and carbon consumption profile of *A. terreus* under the addition of different type of fatty acids**

**Figure 4.6: Effect of fatty acids addition on lovastatin production of *A. terreus***

**Figure 4.7: Effect of fatty acids addition on (+)-geodin and sulochrin production of *A. terreus***

**Figure 4.8: The effect of PG and CG glycerol on metabolite production by *A. terreus* cultivated in bioreactor over 7 days**

**Figure 4.9: The gradual change of colour observed during the cultivation of *A. terreus***

**Figure 4.10: The pre-treatments produced different colours on the CG**

**Table 4.5: The biomass production of *A. terreus* under different pre-treatments of non-polar solvents**

**Figure 4.11: The glycerol consumption and metabolite production of *A. terreus* when under different solvent pre-treatments**

**Figure 4.12: The glycerol consumption and biomass growth by *A. terreus* under the treatment of AC and WS**

**Figure 4.13: The lovastatin, (+)-geodin and sulochrin by *A. terreus* under the treatment of AC and WS**

**Table 5.1: Compilation of possible elicitors used in different organisms**

**Table 5.2: Experimental plans for the elicitation experiment on *A. terreus***

**Table 5.3: Experimental design involving other factors that can stimulate metabolite production by *A. terreus***

**Figure 5.1: Lovastatin, (+)-geodin and sulochrin production in elicitation experiment**

**Table 5.4: Biomass, diameter and density of *A. terreus* under different media treatments in the elicitation experiment**

**Figure 5.2: Glycerol consumption by *A. terreus* under the addition of elicitors in the period of 9 days**

**Table 5.5: The consumption rate and growth of *A. terreus* during 9-days cultivation**

**Figure 5.3: Lovastatin, (+)-geodin and sulochrin production in *A. terreus* during cholesterol investigation**

**Figure 5.4: The contamination and subsequent isolation of the contaminating bacterial strain**

**Figure 5.5: The metabolite production profile of *A. terreus* with the addition of bacterial stock after 48 hours**

**Figure 5.6: Lovastatin, (+)-geodin and sulochrin production in *A. terreus* under cholesterol treatment during 9-day cultivation**

**Figure 5.7: The biomass growth and diameter of *A. terreus* for the period of 6 days**

**Figure 5.8: Substrate (glycerol) consumption by *A. terreus* in shake flask**

**Figure 5.9: Lovastatin, (+)-geodin and sulochrin production by *A. terreus* during the 9-days cultivation**

**Figure 5.10: The metabolite production profile of *A. terreus* under the effect of sonication and friction**

**Figure 5.11: Glycerol consumption profile of *A. terreus* under the effect of sonication and friction**



## NOMENCLATURE

A.	<i>Aspergillus</i>
CVD	Cardiovascular disease
TC	Total cholesterol
LDLC	Low density lipoprotein cholesterol
HDLC	High density lipoprotein cholesterol
HMG-CoA	3-hydroxy-3-methyl-glutaryl-coa
PKS	Polyketide synthase
LNKS	Lovastatin nanoketide synthase
SAM	S-Adenosyl-lmethionine
LDKS	Lovastatin nonaketide Synthase
ORF	Open reading frame
VVM	Volume per volume per minute
PAI	Plasminogen activator inhibitor
CG	Crude glycerol
PG	Pure glycerol
MeOH	Methanol
NaCl	Sodium chloride
KH <sub>2</sub> PO <sub>4</sub>	Potassium phosphate monobasic
MgSO <sub>4</sub> ·7H <sub>2</sub> O	Magnesium sulfate heptahydrate
ZnSO <sub>4</sub> ·7H <sub>2</sub> O	Zinc sulfate heptahydrate
CaCl <sub>2</sub> ·2H <sub>2</sub> O	Calcium chloride dihydrate
FeCl <sub>3</sub> ·6H <sub>2</sub> O	Iron(III) chloride hexahydrate
CuSO <sub>4</sub> ·5H <sub>2</sub> O	Copper(II) sulfate pentahydrate
MnSO <sub>4</sub> ·5H <sub>2</sub> O	Manganese sulfate pentahydrate
B	Ml/grams of hydrochloric acid
C	Catalyst factor
W	Grams of biodiesel
ppm	Per million grams
ICP	Inductively coupled plasma mass spectrometry
v/v	Volume/volume
Wt/wt	Weight/weight
HPLC	High performance liquid chromatography
cDNA	Complementary DNA
PCR	Polymerase chain reaction
Ct	Cycle threshold
SEM	Scanning electron microscope
AS	Ammonium sulphate
SB	Powdered soybean
YE	Yeast extract
X <sub>FINAL</sub>	Biomass final
Ø <sub>FINAL</sub>	Diameter final
C	Metabolite titre
OA	Oleic acid
PA	Palmitic acid
PE	Petroleum ether

DE	Diethyl ether
Tol	Toluene
AC	Activated carbon
WS	Water softener pillow
P	Plant
PC	Plant cell culture
F	Fungi
B	Bacterial cell culture
SA	Sodium alginate
SA2	Alginate without calcium ion
MA	Malonic acid

## Chapter 1 – Introduction

### 1.0 *Aspergillus terreus* ATCC 20542

*Aspergillus terreus* ATCC 20542 is a filamentous fungus that can be found in soil. This fungus grows relatively well at room temperature (25 °C) and usually produce a brownish colour that darkens as it ages on the culture plates (Figure 1.1). Similar to most fungi species, *A. terreus* possesses conidial heads that are compact, biseriate, and densely columnar. Its conidiophores exhibit hyaline and smooth-like appearance while its conidia are globose-shaped (Figure 1.1). *A. terreus* produced aleuriocnidia, a unique asexual spore that are thought to be the reason for its role in opportunistic infection [1]. *A. terreus* is commonly used in industry to produce several important metabolites for human consumption, such as itaconic acid, cis-aconitic acid, enzymes such as xylanase, and perhaps most importantly, lovastatin, a cholesterol-lowering drug.

Lovastatin is a secondary metabolite, which is defined as low molecular mass, organic molecules that are not directly involved in their normal growth, development or reproduction. Although they are not as important as primary metabolites, their absence would probably cause long term defects in their ability to survive, reproduce or aesthetics of filamentous fungi [2]. To date, the function of each secondary metabolite in the natural environment remains unclear and varies with species. However, it is widely accepted that most secondary metabolites are expressed for competitive purposes and are important for their survival, such as defense against predator [3].

Apart from its valuable metabolites, *A. terreus* was selected for this investigation because of its advantageous trait as a fungus. Fungi can metabolise a variety of organic substrates such as starch, protein, lipid, ethanol, nitrates and ammonia more efficiently

than most bacteria [4]. They also require fewer nutrients and supplements during growth, easier to cultivate, less susceptible to contamination and able to produce biomass with high nutritive value [5]. Most importantly, fungi have greater resistance to inhibitory compounds than bacterial species due to their considerably complex structure, attributed to their hyphae, cell wall, and extra-polysaccharide layer which provides extra protection to their organelles [5].

The scope of this review focuses on the fungus strain, mechanism of action and production, and currently available cultivation techniques for lovastatin production of *A. terreus* ATCC 20542. To a lesser extent, the production of its co-metabolites, (+)-geodin and sulochrin will also be discussed.

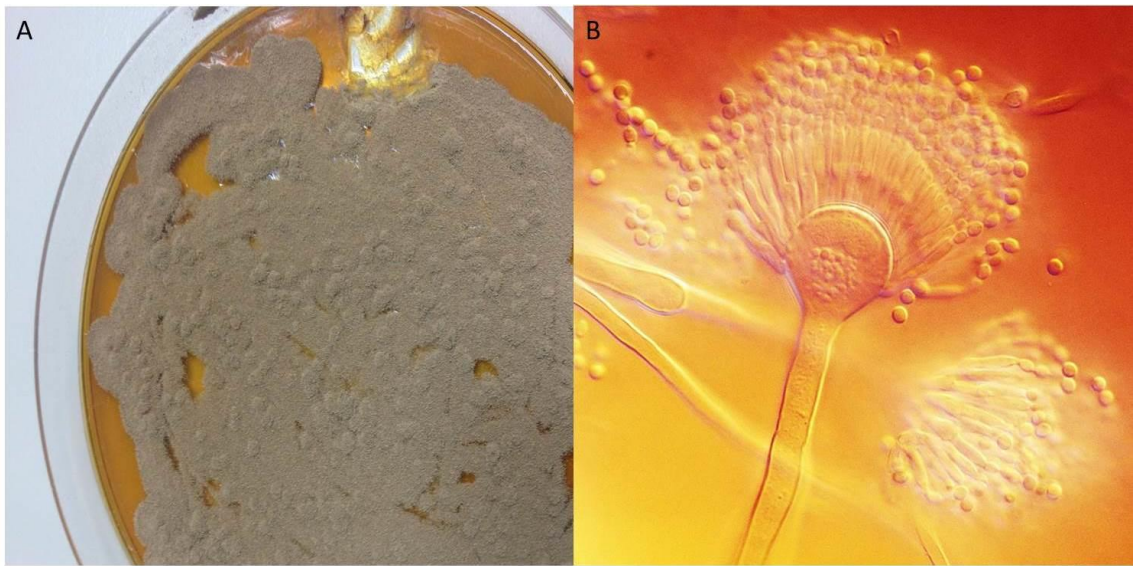

Figure 1.1: **The photographs of *A. terreus*.** (A) *A. terreus* cultivated on Potato Dextrose Agar at day 7 exhibited brownish colour that darkens as the cultivation proceeds; (B) Conidiophore/conidial head of *A. terreus* with spores on Rose Bengal Agar exhibited a hyaline-like appearance, photographed in Nomarski Differential Interference Contrast Microscopy.

## **1.1 Lovastatin, a cholesterol-lowering drug produced by *Aspergillus terreus* ATCC 20542**

Among the most commonly prescribed drugs to lower cholesterol levels are statins [6]. Statins is a group of drugs that specifically inhibits 3-hydroxy-3-methyl-glutaryl-CoA (HMG-CoA) reductase, a rate-limiting enzyme involved in cholesterol biosynthesis in the liver. This effectively lowers the plasma low-density lipoprotein cholesterol (LDL, bad cholesterol), while increasing high-density lipoprotein (HDL, the good cholesterol) and inhibits the subsequent increase in hepatic LDL receptor expression [7]. Subsequently, it can reduce atheroma (accumulation and swelling of arterial walls), thrombus and atherosclerosis formation, improves endothelial function and suppressing inflammatory reaction [8]. Recently, preliminary studies also claimed that statins can potentially treat other conditions, such as osteoporosis [9], Alzheimer's [10], and cancer [11,12].

Commercially available statins can be grouped into three major types; natural, semi-synthetic and fully synthetic. Lovastatin is a natural statin, largely produced by fungi through cultivation process. Statin was first isolated from fungal family, including the *Aspergillus*, *Monascus* and *Penicillium* family [13,14]. The first natural statin, compactin, was isolated in 1976 when a metabolite produced by *Penicillium citrinum* (Figure 1.2) was found to inhibit the activity of cholesterol precursor in rat liver extract [15]. Following this discovery, scientists from Merck performed their own screening and successfully isolated *Aspergillus terreus* ATCC 20452, which was used to produce the first commercialized statins, later named lovastatin [16]. The effectiveness of lovastatin was demonstrated in a large-scale, long term trial of 4444 patients that exhibited congenital heart disease with high plasma cholesterol, where a 30% reduction

in all-cause mortality, 42% reduction in coronary death and 37% reduction in revascularisation procedures were reported [17]. The summary of the history and development of statins is illustrated in Figure 1.3.

The discovery of lovastatin gave rise to other types of semi-synthetic and fully-synthetic statins, including atorvastatin (Lipitor), fluvastatin (Lescol) pitavastatin (Crestor) and simvastatin (Zocor). Pfizer, a large pharmaceutical company, reported US\$12.4 billion in sale in 2008 alone from its atorvastatin (marketed under the brand name 'Lipitor') [18]. The gross sale for atorvastatin from the same company from 1996-2012 was reported to be in an excess of US\$125 billion [18]. Similarly, Merck, the original company that discovered lovastatin, reported a sale of US\$4.4 billion worldwide from simvastatin (under trademark name 'Zocor') in 2005 alone [19].

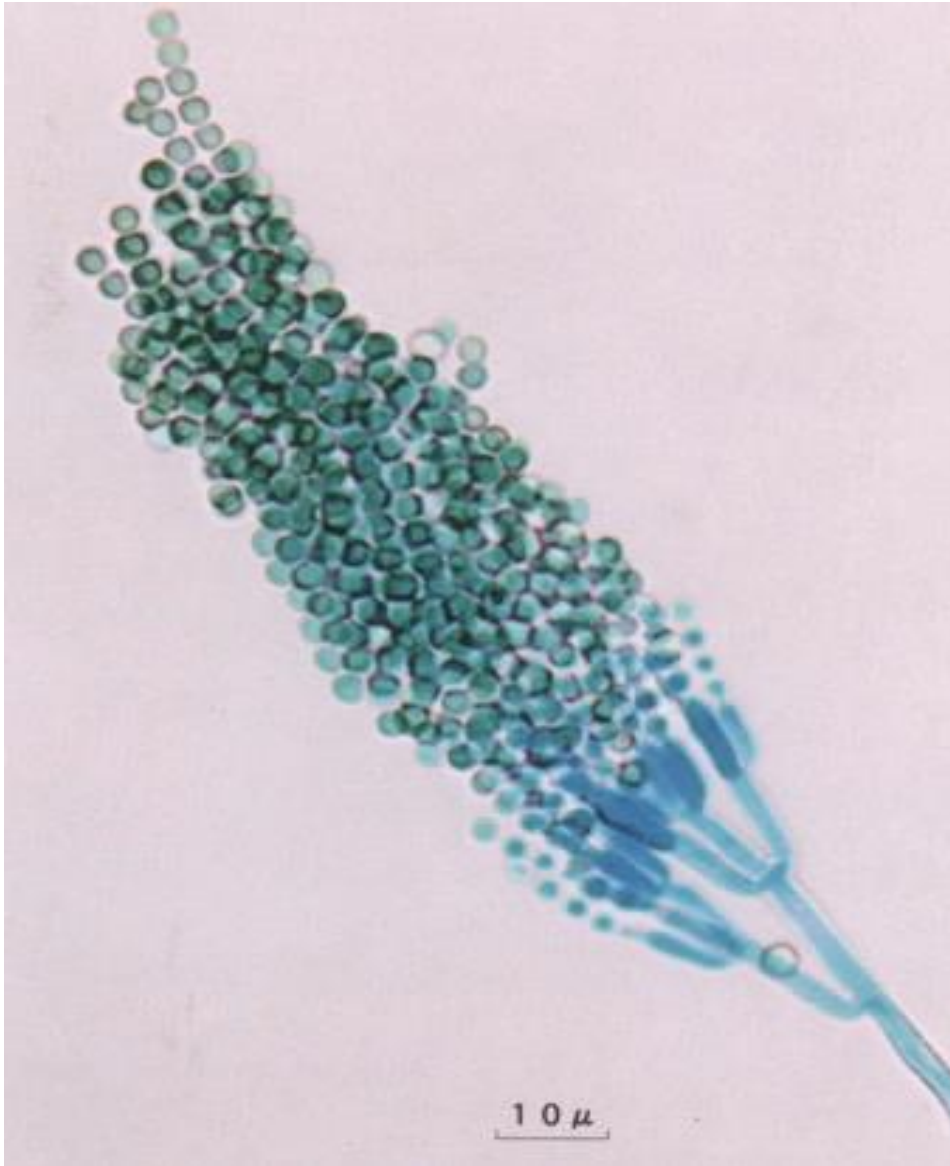

Figure 1.2: **The micrograph of blue-green mold *Penicillium citrinum*.** This strain is the first major compactin producing strain discovered in 1976 by Akira Endo and his team from among 6000 microbes screened. Adapted from [13].



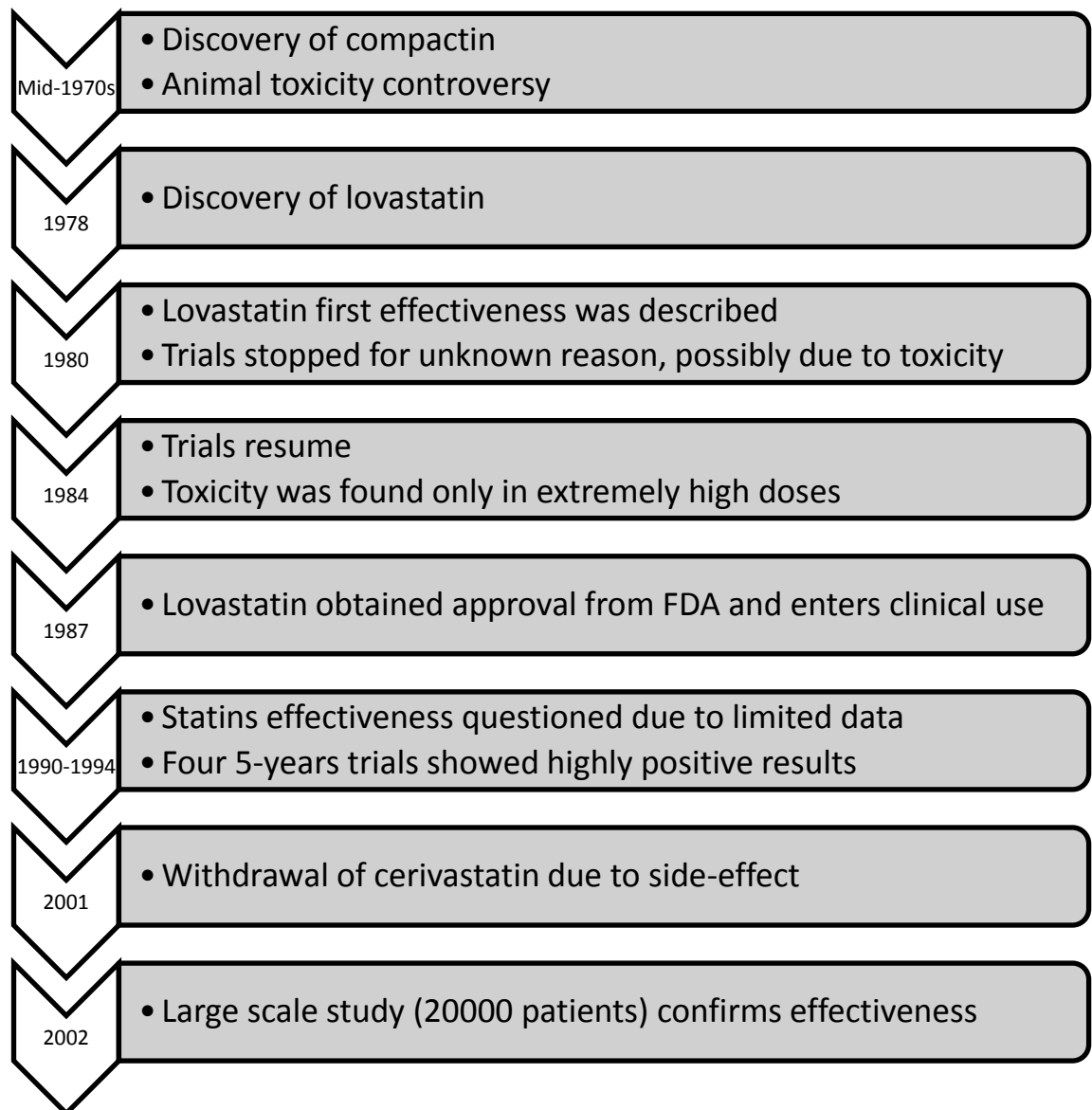

Figure 1.3: **The discovery, development and history of statins.** Adapted from [16].

### **1.1.1 Mechanism of action of lovastatin**

Lovastatin lowers cholesterol levels by competitive inhibition. The biosynthesis of cholesterol involves a series of complicated reactions, initiated by the reaction between acetyl-CoA with acetoacetyl-CoA, which forms HMG-CoA. Further reduction step by HMG-CoA reductase results in the formation of mevalonate compound. Various high energy reactions convert this compound to isopentenyl pyrophosphate, a precursor involved in many biological reactions in the human body, including cholesterol synthesis [20]. The acid form of the lovastatin is similar in structure to HMG-CoA intermediate, but with higher affinity for the HMG-CoA reductase, thereby allowing lovastatin to competitively bind to HMG-CoA reductase and renders it inactive (Figure 1.4). This reaction prevents the conversion of 3-HMG-CoA into mevalonate by HMG-CoA reductase, consequently block cholesterol biosynthesis. This mechanism of action is efficient and safe as it reduces the formation of complex and toxic intermediates [16]. The summary of the reaction is illustrated in Figure 1.5.

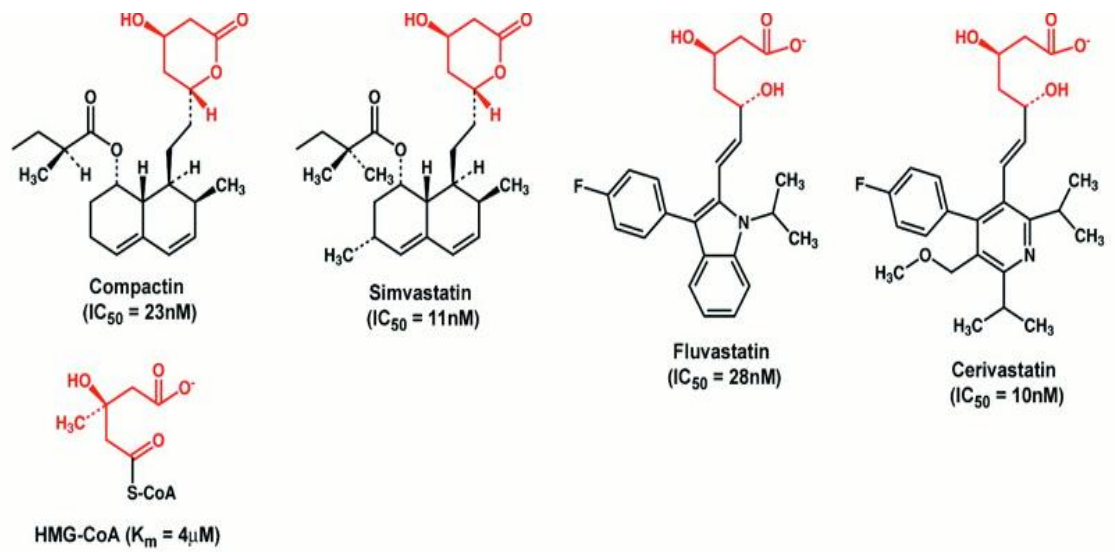

Figure 1.4: The structural similarity of four different statins in comparison to mevalonate, an HMG-CoA intermediate. Adapted from [21].

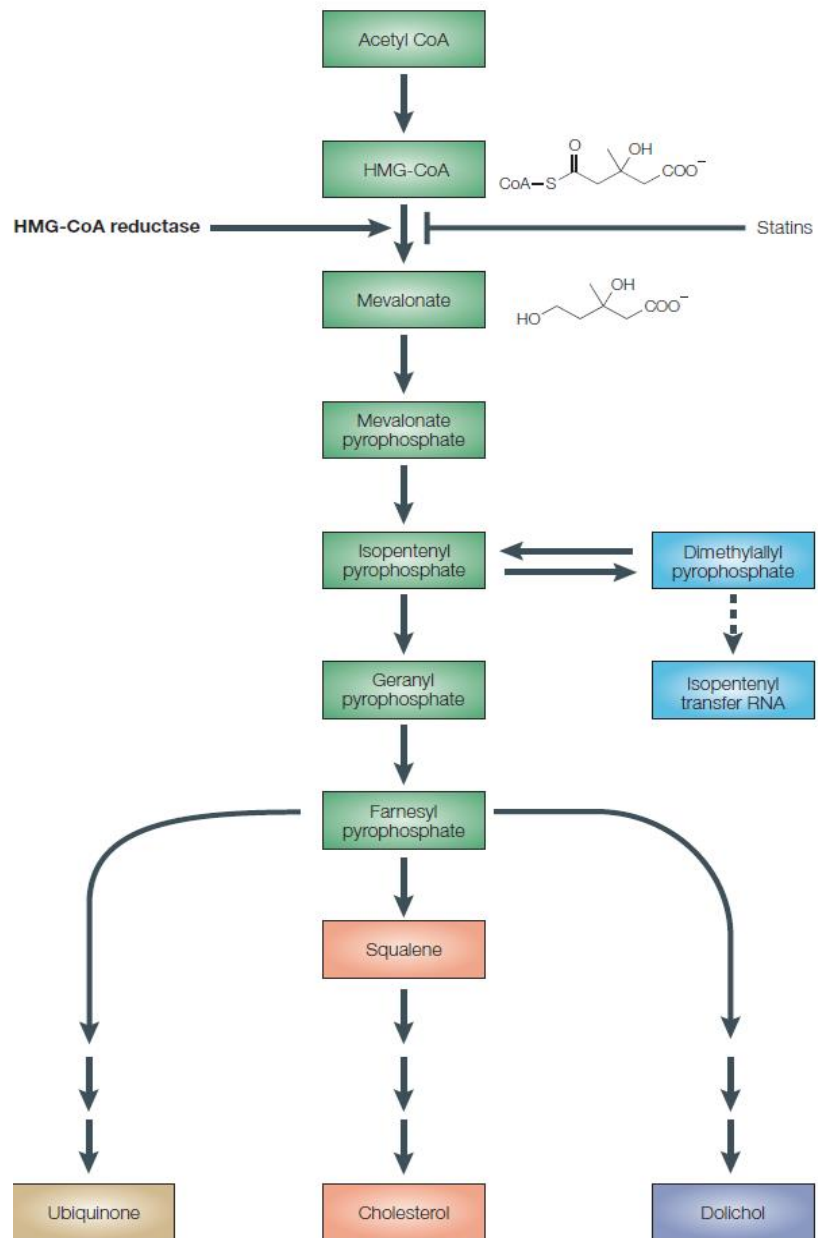

Figure 1.5: **The competitive inhibition by lovastatin of HMG-CoA reductase.** Normal HMG-CoA conversion is depicted on the left while competitive inhibition is depicted on the right. Lovastatin competes with substrate (HMG-CoA) and preventing the formation of a product, mevalonate that is vital for cholesterol biosynthesis. Adapted from [16].

### 1.1.2 Biosynthesis of lovastatin in fungus

The biosynthesis of lovastatin in *A. terreus* has been demonstrated using labelled precursors in a process known as polyketide pathway [22]. This process involves two acetate units merged to form two polyketide chains. The addition of methionine to this reaction results in the addition of methyl groups to the subsequent product. Further modifications are required to form lovastatin molecule as illustrated in Figure 1.6.

Lovastatin biosynthesis involves several enzymes encoded by a gene cluster identified as type I polyketide synthase (PKS), which is commonly found in microorganisms that produce complex secondary metabolites. PKS may differ from one organism to another, as reviewed in [23] and [24]. The resulting metabolite produced may also be subjected to post-PKS tailoring steps that involve several other enzymatic reactions [25]. In lovastatin production, two main stages are involved; PKS (nine-step polyketide formation up to dihydromonacolin L) and post-PKS tailoring hydroxylation and oxidation steps (with molecular oxygen). One of the essential genes in this cluster is *lovB*, or lovastatin nanoketide synthase (LNKS). It contains seven active sites responsible for the arrangement of carbon skeleton in dihydromonacolin L and lovastatin. Another equally important gene, *lovF*, encodes for diketide synthase (DKS) in PKS, which handles the diketide synthase pathway. Characterization of these two genes (*lovB* and *lovF*) revealed the existence of methyltransferase domains in LNKS and DKS, indicating that methyl groups are being added (from S-adenosylmethionine) during polyketide biosynthesis [26,27].

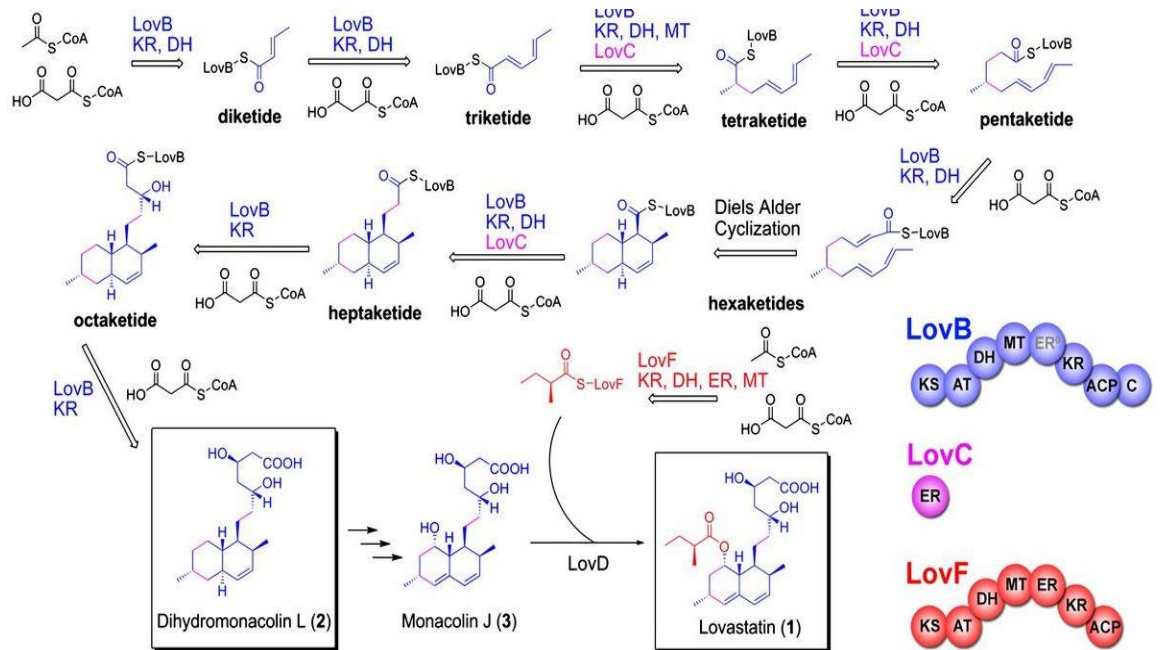

Figure 1.6: Biosynthesis of lovastatin in *Aspergillus terreus* in their acidic form [28].

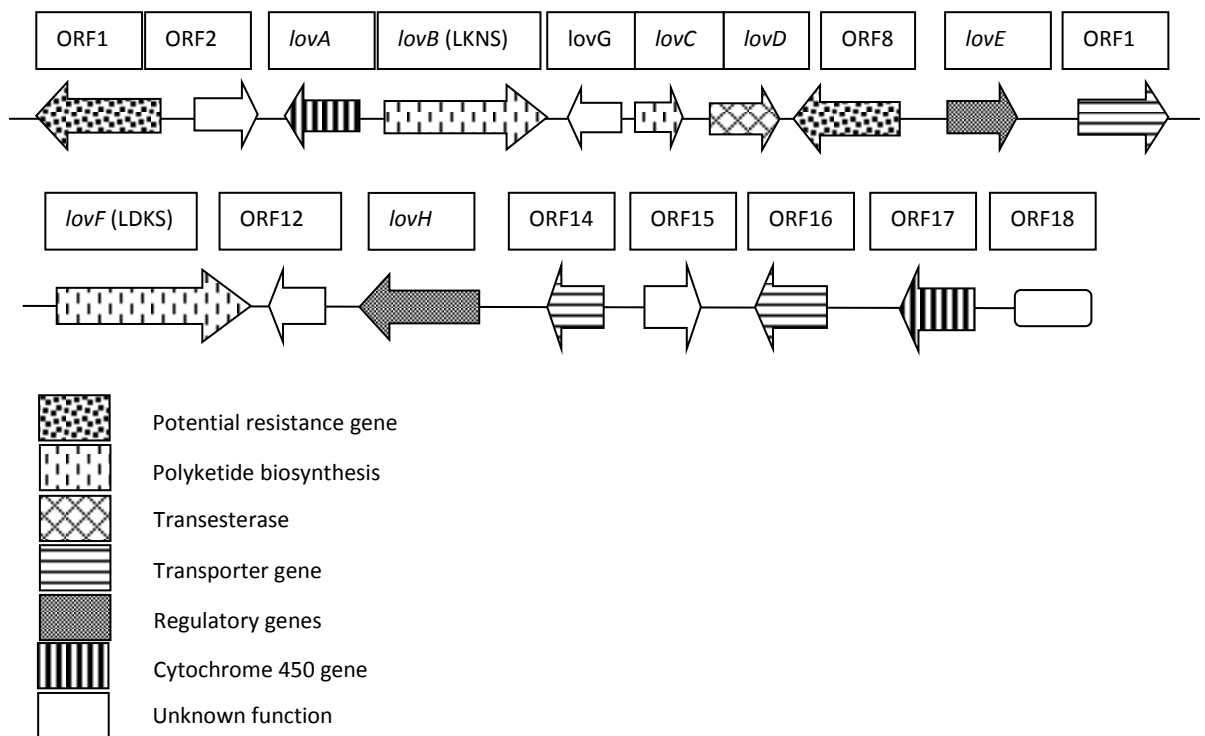

Figure 1.7: **Organization of selected fungal PKS gene clusters in lovastatin biosynthesis.** Abbreviations used: ORF – open reading frame; *lov* - genes responsible for lovastatin biosynthesis.

This gene cluster also includes *lovD*, *lovE*, *lovH*, *lovA* and *lovC* genes with multiple open reading frames (ORF). They all play an important role in the regulation of lovastatin biosynthesis (Figure 1.7) [6]. Both *lovE* and *lovH* are necessary for the production of transcriptional regulatory factors based on the presence of a common  $Zn^{++}$  motif. Both *lovA* and ORF 17 have been shown to encode for putative cytochrome 450 monooxygenases, while *lovC* and *lovD* are important in assisting the correct chain formation of dihydromonacolin J [6].

## **1.2 The factors that influence lovastatin production by *Aspergillus terreus***

### **1.2.1 Dissolved gas and aeration rate**

An important parameter in the biosynthesis of lovastatin is dissolved gas concentration and aeration rate, which are closely related to each other. The effects of dissolved gas concentration and aeration rate can differ between some studies as different approaches and techniques were used for the fermentation. Furthermore, in certain cases where shake flasks (instead of bioreactor) were used, it usually lacks aeration control, and dissolved gas concentration is limited to controlling the speed of the shaking incubator. Lopez C. et al. (2004) attempted to overcome this problem by controlling the dissolved gas concentration in the fermentation chamber of shaking flasks using an enriched oxygen atmosphere while maintaining the sterility [29]. They found that high oxygen-atmosphere (up to 80%) and aeration at 1 volume per volume per minute (vvm) produced a high lovastatin concentration, up to 300 mg/L. This study is also supported by another study showing that up to 70% dissolved oxygen may promote higher lovastatin production [30]. However, any higher concentration may reduce lovastatin production. Similarly, lack of oxygen (below 35%), may also significantly reduced lovastatin production[31]. Nevertheless, the mechanism that contributes to the increase in lovastatin production with increased oxygen content is still unclear, although it has been hypothesized that oxygen is essential for the post-PKS process in lovastatin biosynthesis [32].

While the effect of oxygen content on lovastatin production is generally similar across most studies, the effect of aeration is still under debate. Although the effect of aeration is often linked to the dissolved oxygen concentration, aeration provides an extra effect of shear force that may affect the fungus physiologically. The most obvious example



was demonstrated by Porcel R. et. al (2005), where it was observed that aeration may cause the fungal pellet to change a number of its key morphological features [33]. Similar effects were not reported in the presence of high oxygen content. Higher aeration has been implicated with higher lovastatin production [34]. The increase is most likely due to the increase in oxygen intake, as high oxygen availability is important for lovastatin biosynthesis [35]. However, another study demonstrated the opposite and claimed that higher aeration enhances the formation of by-products such as (+)-geodin [36]. It has been argued that greater aeration may induce the post-PKS steps that lead to the formation of by-products, and ultimately reduces lovastatin production [36].

### **1.2.2 The pH of the culture media**

pH is important as it regulates chemical reactions necessary for growth, metabolism and final product. For lovastatin production, there is a consensus on the optimum range of initial pH in the media, which ranges between pH 6 to 7 [36–39]. On the contrary, the pH profiles obtained during cultivation usually differ from one study to another as this is influenced by setup systems used (media, bioreactor, aeration and dissolved oxygen). pH fluctuations were observed when different carbon sources were used during cultivation [38]. For example, lactose-based media was shown to increase pH up to 7, followed by a gradual decrease towards the end of fermentation. In contrast, glucose-based media caused a drop of pH down to 5.5 during the early stage of fermentation before increasing again to 6 [38]. In another study, Lai et al. observed that the pH drops faster in a bioreactor (24 hours) when compared to shake flask (48 hours), before increasing again [39]. An attempt to control the pH of fermentation using *A. terreus* did not meet with great success [40]. These fluctuations are thought to reflect typical fungal

metabolism and any changes to this condition may lower lovastatin production [40]. However, pH control using a well-thought strategy was successful in improving lovastatin production. It was achieved by determining specific pH needed *A. terreus* at particular stages of cultivation and using only specific carbonates buffer. The carbonate buffer is hypothesised to be beneficial in forming malonyl-CoA, an important precursor for lovastatin biosynthesis [36].

### **1.2.3 Fungal morphology**

*A. terreus* can grow either as pelleted or dispersed hyphae in submerged culture. It is generally accepted that increased efficiency of lovastatin production can be achieved with the pellet form of *A. terreus* [31,34,41]. Although the method is still unclear, the formation of *A. terreus* pellet is thought to be either from the single or aggregation of spores [42]. Pellet growth can be characterized by its diameter, filament ratio diameter (ratio of peripheral hairy surface with total area of the pellet), surface morphology (smooth or hairy) [33] and the ratio of active sites in the pellet [43].

There are some debates about the effect of pellet diameter size on lovastatin production. While some studies have shown that larger pellet size, or diameter (>3 mm), is associated with higher lovastatin production [33,34], others have shown high lovastatin can also be achieved with small or medium size pellet (1.8 – 3 mm) [43,44]. This is thought to be due to the higher ratio of the active apical site in the smaller pellet in the context of its surface area [43], thereby improving the lovastatin biosynthesis. A similar study also suggested that the active apical ratio may determine the pathway of metabolite production such that the higher ratio favors lovastatin production while smaller ratio favors (+)-geodin (by-product) production. However, some studies argued that large diameter may result from increased oxygen intake by the fungus, which may

enhance lovastatin production [32,34]. The effect of filament ratio diameter will not be reviewed as the impact towards lovastatin production is still unclear.

The fungal morphology is also affected by several other factors including spore amount and sonication [43,45]. Larger spore amount (up to  $10^{10}$ /L) may produce more pellets at smaller sizes, thus increasing the lovastatin production [43]. The authors, however, never measured the production of lovastatin per pellets, which makes it difficult to determine whether small pellet produced higher lovastatin than the larger ones. The increase of lovastatin in the media was most likely due to the greater number of pellets in the culture as a result of higher initial spore number, as each pellet may contribute to lovastatin production. While sonication has been shown to improve metabolite production in other organisms [46–48], such an effect was not observed in *A. terreus*. In fact, sonication appeared to lower lovastatin production by approximately 28% [45]. Furthermore, intense sonication has also been reported to affect negatively the morphology of the fungus as the growth was shifted from pellet form to dispersed hyphae form. This morphological change is most likely the reason for the lower lovastatin production.

#### **1.2.4 Culture media**

Carbon and nitrogen are arguably the most important nutrients for fungi growth and its metabolite production. Carbon source is often associated with metabolite production, whereas nitrogen is essential for the growth of the fungus. The choice of carbon source can vary between organisms and is dependent on various factors. Glucose is traditionally used as the main carbon source in most industrial fermentation due to their simple, growth-inducing and rapid utilisation nature. Although *A. terreus* can use glucose for their normal growth, this strain appears to favour a complex and slow-

metabolised carbon source, such as lactose or glycerol for lovastatin production [49]. The use of a rapidly-metabolized carbon source, such as glucose, may cause the formation of unwanted by-products, such as ethanol, with minimal lovastatin production due to possible catabolic repression [37].

Carbon source (g/L)	Nitrogen source (g/L)	Lovastatin (mg/L)	Strain	Reference
Lactose (20)	CSL (10)	400	TUB F-514	[50]
Sucrose (50)	CSL (2.5) Soybean meal (2)	160		
Glucose (45)	Sodium glutamate (12.5)	200	ATCC74135	[37]
Lactose (53)	Peptonised milk (24) Yeast extract (2.5)	120		
Glucose (45)	Peptonised milk (24)	300		
Glucose (45)	Ammonium	0		
Glucose (15), maltodextrin (32), starch (20), lactose (N/A)	CSL (5), yeast extract (2.5), peptonized milk (25)	1200	Mutant strain of ATCC20541	[51]
Fructose (20)	Yeast extract OR	40 – 120	ATCC20542	[49]
Glycerol (20)	sodium glutamate OR			
Lactose (20)	CSL (0.144 – 0.172)			
Glucose (45)	Yeast extract (12.5)	12	ATCC20542	[52]
Lactose (20)	Yeast extract (8)	35	ATCC20542	[53]
Lactose (5-40)	Yeast extract (2-12)	5-110		

Table 1.1: **The use of carbon and nitrogen sources for lovastatin production.** Note that there is no consistent amount of lovastatin being produced, as different experimental conditions were employed in each investigation. Abbreviation: CSL – corn steep liquor.

It was reported that the lovastatin production can reach up to 5-fold higher with slowly-metabolized carbon source compared to rapidly-metabolized carbon source [38]. Although the reason is still unclear, one possible explanation may be that complex carbon sources prolong the phase of secondary metabolite production in *A. terreus*. This hypothesis was supported by Lopez C. et. al (2003), when lactose was shown to produce higher lovastatin compared to the other carbon sources [49] (Table 1.1). However, using

the same carbon source with different nitrogen source would give different lovastatin yield (Table 1.1). This observation suggested that the combination of the carbon and nitrogen source was probably more important than the rate of consumption itself. Furthermore, there were also instances when a good production of lovastatin can be achieved when glucose (a rapidly-metabolise carbon) was used [37,51]. Hence, further experimentation is probably required to validate the theory. The requirement for the type of carbon source might be stage-specific, such as the early growth of *A. terreus* requires rapidly-metabolised carbon while the latter stage of metabolite production requires slowly-metabolised carbon. This condition was demonstrated by Pecyna M. Et al (2011), when a mix of a rapidly- and a slowly-metabolised carbon sources produced a reasonably high lovastatin production [54].

In industrial fermentation, the use of complex nitrogen sources is unfavourable due to their high cost and low reproducibility. However, in case of *A. terreus* fermentation, a single nitrogen source, such as amino acids and ammonium ions did not give satisfactory lovastatin production [37,41]. The use of single amino acids such as histidine or sodium glutamate only produced several tens of milligrams per litre [37]. Although the fungus in culture commonly prefers ammonium ions as their nitrogen source, this option is not feasible for lovastatin production as this will acidify the medium and thus may inhibit the formation of lovastatin [41]. Most studies using a complex nitrogen source for lovastatin production, such as yeast extract, corn steep liquor and peptonised milk have met with greater success [34,37,49] (Table 1.1). Complex nitrogen sources generally comprised of various organic nitrogen compounds, which are mainly amino acids and proteins.

Studies have also suggested that the ratio of carbon to nitrogen plays a role in lovastatin production. A higher ratio up to 41:3, may contribute to greater lovastatin production while a lower ratio may stimulate cell growth [49]. A study using lactose as a carbon source showed that lovastatin biosynthesis is limited by the amount of carbon source present in the media. The optimal amount of lactose (carbon source and yeast extract (nitrogen source) in that study was 20 g/L and 4 g/L, respectively [36]. Lopez C. et al. (2003) also reported that the highest production of lovastatin was obtained during the nitrogen-limited growth or starvation period [49]. This observation may be caused by the inhibitory characteristics of organic nitrogen in the media [53]. These views, however, are refuted by Hajjaj et al. [37]. In their study, they found that carbon starvation is more prominent in inducing lovastatin production, as they only observed its production after the carbon was exhausted. All the studies mentioned, however, pointed to a similar conclusion that higher carbon to nitrogen ratios produce better lovastatin production.

The presence of macro and micronutrients in the growth medium has also been shown to influence lovastatin production. These nutrients are not essential for the microorganism growth, but act as supplements to achieve better fermentation. Certain divalent metal cations (from mineral salts) such as  $\text{Fe}^{2+}$ ,  $\text{Ca}^{2+}$ ,  $\text{Zn}^{2+}$ ,  $\text{Mg}^{2+}$  and  $\text{Mn}^{2+}$  were reported to improve the growth and lovastatin production [55]. In a more specific study conducted by Bizukojc et.al, his team postulated that certain vitamin B may enhance lovastatin formation by providing more precursors (for examples, NAD(P), FAD, coenzyme A and protein biosynthesis) for lovastatin biosynthesis. In his investigation, most of the vitamin B (riboflavin, pyridoxine hydrochloride, calcium panthothenate and nicotinamide) improved lovastatin formation. The improvement was further observed when the combination of vitamin B was used [56]. The addition of

butyrolactone I, a self-regulating metabolite that stimulate lovastatin formation, to the culture of *A. terreus* has also been performed by Schimmel et al. Their study demonstrated that butyrolactone I increased the branched hyphae, the number of spores and the production of lovastatin. [57].

### **1.3 (+)-geodin and sulochrin in *Aspergillus terreus***

Apart from lovastatin, *A. terreus* also produces a range of other secondary metabolites during its cultivation. This study is interested in two of these, namely (+)-geodin and sulochrin, and their production will be reviewed in this section. Although these compounds can also be found in other microorganisms, both (+)-geodin [58] and sulochrin [59] were originally isolated from *A. terreus*.

#### **1.3.1 (+)-geodin**

(+)-geodin [(2R)-5,7-dichloro-4-hydroxy-6'-methoxy-6-methyl-3,4'-dioxospiro(benzofuran-2(3H),1'-(2,5)-cyclohexadiene)2'-carboxylate] is the primary co-metabolites of lovastatin. Hargreaves et al. (2002) managed to isolate and subsequently to predict the structure of (+)-geodin and their function [58]. (+)-geodin can be the most abundant metabolite found in *A. terreus* fermentation after lovastatin [22,60]. Both lovastatin and (+)-geodin come from a similar pathway of polyketide synthesis, although their formation involves different molecules and products towards the end of their synthesis (Figure 1.8). Most of (+)-geodin's formation involves octaketides (such as emodinanthrone) and uncharacterised octaketide synthase (such as emodinanthrone oxygenase) but none of these molecules are involved in lovastatin biosynthesis. While post-PKS process (oxidation and methylation) is also required in lovastatin formation,

(+)-geodin's formation requires additional post-PKS tailoring steps, which produce certain compounds such as emodin, questin, sulochrin and finally (+)-geodin.

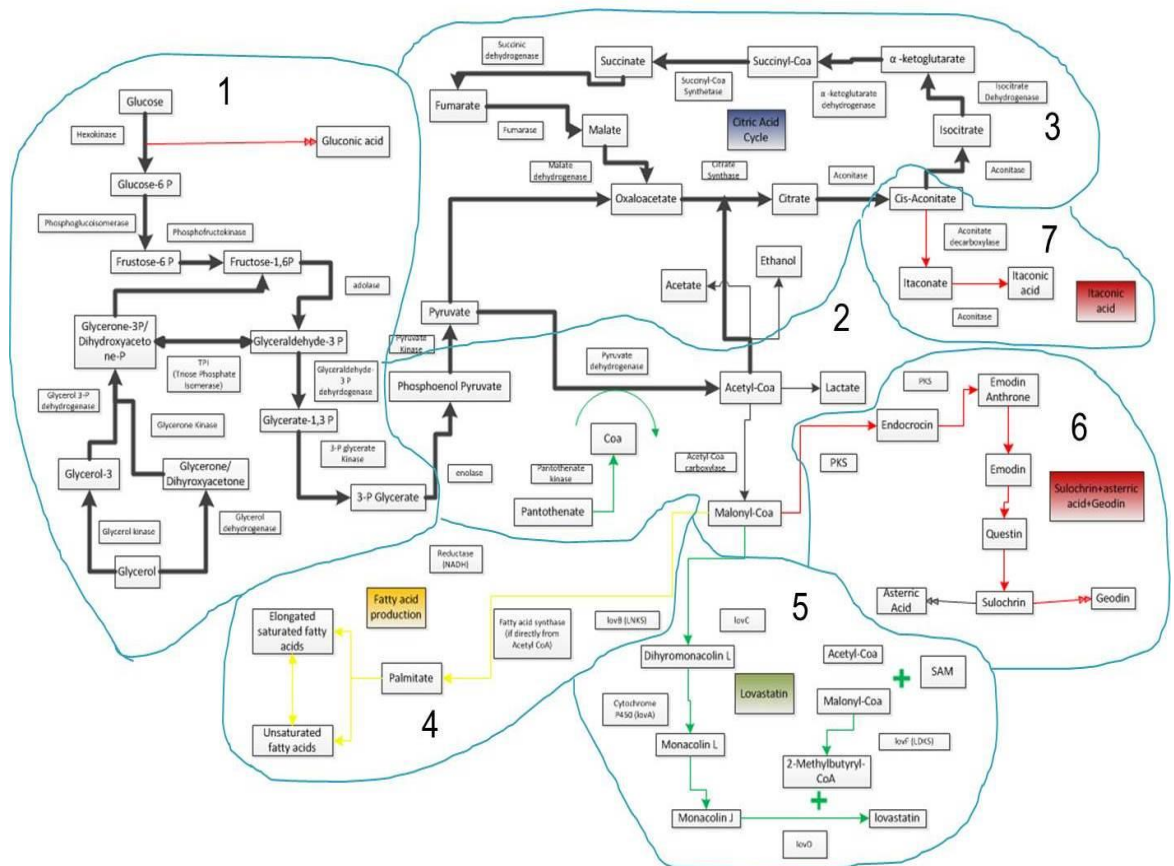

Figure 1.8: **The biosynthesis of lovastatin, (+)-geodin and sulochrin.** The labelled circles indicate the section where the specific reaction occurs. 1) Substrate (s) was taken. 2) The precursors for biochemical reaction inside *A. terreus* 3) The energy production. 4) The biomass production. 5) Lovastatin production. 6) (+)-geodin and sulochrin production and 7) itaconic acid production.



In the clinical setting, (+)-geodin has been shown to inhibit plasminogen activator inhibitor (PAI-1), a molecule that is important in fibrinolysis mechanism and for the stimulation of glucose uptake in rat cells [61]. In term of *A. terreus* survival, (+)-geodin may act as mycotoxin [62], antiviral, antimicrobial and antifungal agent [58].

Bizukojc M. et al. (2007) observed that (+)-geodin production is significantly influenced by the amount of initial carbon source in the media. The optimal amount reported ranges between 20 to 40 g/L for lactose, and an additional amount of lactose is required towards the end of the fermentation to improve its production. The production of (+)-geodin has been shown to be greatly reduced with insufficient carbon source or in the presence of high organic nitrogen concentration [60]. Supplements such as certain vitamin B (nicotinamide and riboflavin) have been shown to improve (+)-geodin production. [56]. (+)-geodin production also depends on the aeration rate [34,36]. Up to 10-fold increase in (+)-geodin production was obtained with increased rate of aeration; however this negatively affects lovastatin production. It is currently unknown whether the increase of (+)-geodin caused the decrease of lovastatin, or the aeration itself is the cause. It was suggested that increased aeration stimulates oxygen uptake by cells, in turn improving (+)-geodin formation rather than lovastatin given that (+)-geodin production has higher oxygen demand [35].

In terms of morphology, (+)-geodin production is not influenced by the ratio of filament ratio diameter. Instead, (+)-geodin production is more responsive to the change of diameter of the fungus pellet [43]. Further investigation revealed that bigger pellet is associated with the increase in the geodin active site which governs its production. Hence, by reducing the number of spores cultivated in fermentation, bigger fungus pellet can be obtained and subsequently increased (+)-geodin production [43].

### 1.3.2 Sulochrin

Sulochrin [methyl 2-(2,6-dihydroxy-4-methylbenzoyl)-5-hydroxy-3-methoxybenzoate] is another major co-metabolite of lovastatin. Referring to Figure 1.8, sulochrin is a precursor to (+)-geodin. In the clinical setting, sulochrin was shown to inhibit the activation of human immune cell (eosinophil), endothelial cells and certain cytokine release (IL-8 and LTC<sub>4</sub>). Their function for *A. terreus* survival, however, is not very well-documented. Sulochrin was only mentioned briefly to act as an antibiotic [63]. As one of the primary co-metabolite of lovastatin production, sulochrin is thought to be unneeded in fermentation, due to its possible role in competing with lovastatin production [64]. Compared to (+)-geodin, the research regarding sulochrin production is much limited. It is said that the production of sulochrin is stimulated by the presence of butyrolactone I, another metabolite that is also produced by *A. terreus* [57]. Interestingly, as discussed before, butyrolactone I is also the major metabolite that induce the formation of lovastatin. Hence, eliminating sulochrin production might improve lovastatin production by reducing the competition. However, further experiment to characterise their production should be done as their link with lovastatin production is still unclear, whether the synthesis of these metabolites would inhibit, compete, or induce more lovastatin.

## **1.4 Summary of literature review findings, knowledge gap, and proposed investigation**

This literature review indicates that culture media play an important role in dictating the production of metabolites by *A. terreus*. To date, a standard media conditions for the cultivation of *A. terreus* is lacking. Therefore, the first part of our study aimed to optimise the basic media for metabolite production by *A. terreus*. In particular, selected salts, spore condition and nitrogen sources would be tested for their capability to induce lovastatin production.

The most important media optimisation involved the effect of different carbon sources, particularly carbohydrates, on the production of lovastatin, (+)-geodin and sulochrin. The literature review indicates that the preferred carbon source for lovastatin production is slowly degradable carbon sources, such as lactose and glycerol [49]. However, other researchers have also showed that fast-utilised carbon sources, such as glucose, may also produced a good amount of lovastatin (refer Table 1.1). This disagreement may be caused by different cultivation techniques or conditions. Thus, more detail work will be done to access whether the rate of carbon utilisation is important for lovastatin biosynthesis by *A. terreus*.

*A. terreus* is easier to cultivate, less susceptible to contamination and have greater resistance to inhibitory compounds compared to bacterial species [5]. These characteristics allow us to utilise the cheap and unused dirty substrate from industrial by-products, such as CG. The culture of this fungus on this dirty substrate has never been attempted before. *A. terreus* has been previously demonstrated to produce itaconic acid from glycerol [65,66], but its ability to produce lovastatin from CG is unknown. In

this study, crude and pure glycerol would be used to measure the level of inhibition caused by the presence of contaminants. Subsequently, the effect of contaminants on culture performance will be assessed using partially purified CG.

Based on the literature, two of the most profound co-metabolite of lovastatin are (+)-geodin and sulochrin which are derived from a separate polyketide pathway involved in lovastatin formation. (+)-geodin and sulochrin are often found in large amounts. However, their relationship with lovastatin production is still unclear. We assessed the growth of *A. terreus* and the production pattern of these metabolites in the presence of selected “elicitors” which are chemical or physical factor that can provoke the defense system of the fungus. For this investigation, the chemical elicitor selected are sodium alginate, cholesterol, and malonic acid, whereas the physical elicitor selected are the shear force. These experiments would, hopefully, provide a better understanding of the relationship between these three metabolites.

## 1.6 General and specific objectives of thesis

The overall aim of this thesis is to measure the production of lovastatin, (+)-geodin and sulochrin by *A. terreus* under different conditions.

The specific objectives of this project are:

- a) To study and prepare the optimal media composition for *A. terreus* cultivation
- b) To determine the best carbon sources for the production of lovastatin
- c) To conduct a pilot study on the effectiveness of bio-waste crude glycerol on the growth of *A. terreus*
- d) To induce and establish a relationship between the production of lovastatin, (+)-geodin and sulochrin using elicitors
- e) To evaluate the general morphology of *A. terreus* under different treatments

## **Chapter 2 - Materials, methods and optimisation**

### **2.1 Description of crude glycerol used in the study**

CG samples were kindly provided by Biodiesel Producers Limited (Melbourne, VIC). The plant used a mixture of tallow and used cooking oil to produce biodiesel. The CG exhibits dark yellow colour and has a pH of 7. The CG was stored in a sealed aluminium container at room temperature. Depending on the type of experiment conducted, the CG was either filtered to remove the undissolved contents, autoclaved to remove methanol or vigorously shaken to evenly distribute all the contents.

The determination of the major CG contents was done in our lab using MSDS sent by the company as a reference. Glycerol content was determined using glycerol calorimetric detection reagent from Sigma-Aldrich (refer section 6.5.2: Glycerol calorimetric detection). Methanol (MeOH) was determined using the spectrophotometric method [67]. In short, 100 ml of 10% sodium nitroprusside was mixed with 10% potassium ferricyanide and 5% sodium hydroxide as the main reagent in a plastic container. The solution was then diluted to a total of 600 mL of chromogenic solution. This reagent was protected from light at 4 °C. The sample to reagent was mixed at 1:5 ratios. The sample was shaken gently before incubation at room temperature for 15 minutes. The absorbance of the sample is measured using Cary 50 Bio UV-Vis Varian spectrophotometer at 485 nm.

Sodium chloride (NaCl) was determined using commercially available kits (LaMotte, Maryland, USA). The kit used titration method to determine the amount of NaCl. Soap content was determined using a simple chemical titration method. Isopropyl alcohol (100 mL), which was used as a solvent, was added to 10 g of sample (CG). While

stirring the solution, a few drops of bromophenol blue indicator solution were added to measure the pH. The beaker was weighed and followed by the addition of 0.01M HCl buffer solution until the colour of the solution turns from blue to yellow. The final amount of soap was calculated based on the differences of weight:

$$\frac{B \times 0.01 C}{1000 \times W} = \frac{\text{Grams of soap}}{\text{Grams of sample}}$$

**Where:**

- $B$  = ml (or grams) of 0.01N HCL added.
- $C$  = Catalyst Factor (320.56 for KOH, 304.4 for NaOH)
- $W$  = grams of biodiesel in solution (should be 10g)

The final result can be obtained by multiplying the equation by one million to get grams of soap per million grams (ppm) of the sample.

To determine the safety of CG, inductively coupled plasma mass spectrometry (ICP) was used to determine the heavy metals content in CG (refer section 2.5.3: Inductively coupled plasma mass spectrometry).

## **2.2 Pre-treatments of crude glycerol**

Several pre-treatments were performed to improve the overall quality of CG used in the cultivation. The pre-treatments include solvent washing, activated carbon washing, reduction of water hardness and free fatty acids removals.

The pre-treatment using solvent washing was performed to dissolve hydrocarbons present in CG. Different non-polar solvents (hexane, heptane, octane and petroleum ether) were used to wash the CG at room temperature using 1:1 volume ratio, followed by shaking at 200 rpm. After three hours of mixing, it was centrifuged at 3000g for 2 minutes to separate the mixture into two distinct phases, that is, the upper phase of solvent and the lower aqueous phase of glycerol containing residual impurities. The lower phase was subjected to washing again with fresh solvent and the process was repeated to collect the final treated CG.

The second pre-treatment involved the use of activated carbon purchased from MARS Fishcare North America (PA, USA). The CG used in this pre-treatment was diluted with the same volume of deionised water to reduce its viscosity. Around 20% (wt/v) activated carbon was added directly to the diluted samples, following the incubation at 200 rpm at room temperature for 3 hours. The samples were later centrifuged at 3000g for 15 minutes, and the deposit (activated carbon) was removed to obtain the CG.

Fatty acids removal was done according to Sneha et. al [68]. CG was diluted in water (1:3 ratio) and was vortex vigorously. Next, the pH of the solution was adjusted to 4 by using hydrochloric acid to convert the soluble fatty acids into insoluble fatty acids. The residue was then separated from crude glycerol after centrifugation at 3000g for 15 minutes. Finally, the CG was readjusted to pH 7 using sodium hydroxide.



### 2.3 Culture conditions

The fungal strain used in this study is *Aspergillus terreus* ATCC 20542. The fungal strain was restored according to the supplier's recommendations (Cryosite Distribution Pty Ltd, Sydney, Australia). The tip of the fungal vial was heated before applying a few drops of water to crack the tip. The cracked tip can be broken easily to expose the inner vial that contained the fungus. The freeze-dried fungus was then rehydrated with 1 mL of sterile deionised water for 2 hours before transferred to and maintained on potato dextrose agar at 30 °C for 7 days. The spores were harvested with 0.001% (v/v) tween 80 in sterile deionised water and kept at 4 °C until further use. The spore can also be stored for long term used by adding 15% glycerol and kept at -80°C. The spore numbers were determined using a haemocytometer. Spore suspension was adjusted to  $10^7$  spores/mL before inoculation in 125 mL Erlenmeyer flasks with a total volume of 50 mL culture media.

The spores were grown at  $185 \pm 5$  rpm and a temperature of  $30 \pm 1^\circ\text{C}$  in a shaking incubator. The basic basal medium was used for the experiments (0.4 g/L  $\text{KH}_2\text{PO}_4$ , 0.2 g/L  $\text{MgSO}_4 \cdot 7\text{H}_2\text{O}$ , 0.4 g/L NaCl, and 0.001 g/L  $\text{ZnSO}_4 \cdot 7\text{H}_2\text{O}$ ), unless stated otherwise. Yeast extract was used as the sole nitrogen source at 4.0 g/L (10 % wt/wt of N and 9% wt/wt of C)[49]. The pre-culture was prepared in a similar basal medium, but with lower carbon source (10 g/L) and higher nitrogen source (yeast extract) at 8 g/L to drive the growth of the fungus between 24 to 30 hours to allow the fungus to achieve exponential growth before cultivation. The fungus was used for cultivation when the diameter of the fungus pellet reached  $1.5 \pm 0.5$  mm, measured using a digital calliper. If the solution turns cloudy without visible pellet growth, the culture was considered

contaminated and should be discarded. The day of the pre-culture is considered as Day - 1.

The transfer of fungus pellet from pre-culture media to culture media involved several steps (in a sterile condition). A sterilised strainer was used to recover the fungus from the pre-culture flask and washed with sterile deionised water twice. The fungus collected was then transferred to a new flask with the appropriate culture medium. All the process was done either under the fume hood or by the Bunsen burner.

### **2.3.1 Shear pressure study**

The basic culture conditions are as described in Subsection 2.2: Culture Conditions, with slight modification. Instead of using a shaking incubator, the flasks were incubated in a water bath at  $30 \pm 1^\circ\text{C}$ , followed by shaking at 150 rpm. To create the effect of friction, a small piece of linen cloth (5 x 5 cm) was placed at the bottom of the flask. To create the effect of sonication, a sonicator head (UP400S, Hielscher Ultrasonics, Germany) was carefully placed into the water bath. The sonication is performed continuously for the whole duration of the experiment at 40 kHz.

### **2.3.2 Bacterial-induced elicitation study**

The flask containing the contaminated pre-culture media was removed from the shaking incubator and plated on the PDA plate. The bacterial growth was kept at  $30 \pm 1^\circ\text{C}$  in the incubator. If needed, the bacteria colony can be harvested using sterile deionised water and added to the culture medium.

## **2.4 Fungal biomass dry weight determination**

The biomass yield was determined gravimetrically. Fungus biomass was recovered by filtration using No. 2 Whatman filter paper and washed twice with distilled water, followed by drying at 80 °C for 24 hours or until a constant weight is achieved.

## **2.5 Bioreactor study**

The bioreactor (Real Time Engineering Pty. Ltd., Australia) with 2 to 5 L working volume was agitated by a two-level mixing impellers (radial flow) and a Boehm Frame 23 motor with a speed range of 0-1200 rpm. A manual peristaltic pump was used for pH control which can be controlled by a relay switch on its power connection. Two feed pumps (Grundfos Alldos DMS-A) with maximum flow rates of 2.5 and 7.5 L/h were used. The feed pumps were calibrated before use according to the manufacturer's instructions. Both the speed of the mixing impellers and feed pumps can be set manually or via an analogue signal. A simple vacuum pump (240 V) with a sterile filter was used for air supply.

The bioreactor medium pH was measured by an AppliSens Z001038510 pH probe. Dissolved oxygen in the medium was measured using an AppliSens Z010059020 oxygen probe. The volume of dissolved oxygen was fixed at 70%. Adapters to fit to 19 mm ports were used for both probes. A resistance temperature detector served as a temperature sensor in the bioreactor. Critical foam levels were measured using a conductivity sensor attached to the bioreactor.

Julabo MB-5 water bath with integrated thermostat was used for the heating and cooling of the bioreactor. The water from the Julabo was circulated through the metal jacket

until the intended temperature ( $30 \pm 1^\circ\text{C}$ ) was achieved. Communication with this device was accomplished using an RS 232 interface. Julabo MB-5 was also used for calibration of the thermometer.

Signals from probes, the thermometer and the conductivity sensor were amplified by a FermTx amplifier. Inputs from the amplifier were gathered over an NI FP-AI-110 analogue input module. Analogue outputs for feed pumps and the stirrer motor were generated by an NI FP-AO-200 analogue output module. Relay outputs for the air pump and the pH pump were produced by an NI FP-RLY-422 relay module. Communication with these modules was achieved by an NI FP-1601 network module, which was connected to the computer via Ethernet. All analogue signals ranged from 4 to 20 mA.

The bioreactor interface was designed using National Instruments (NI) LabVIEW 7.0. A NI FieldPoint 4.0 driver package was installed to enable communication with the Fieldpoint Ethernet module. PID control blocks were taken from the NI LabVIEW PID and Fuzzy Logic toolkit. A LabVIEW Visual Interface (VI) for the communication with the heating/cooling device via an RS 232 interface was made available upon request by Julabo Labortechnik GmbH, Seelbach, Germany. The full schematic of the bioreactor is shown in Figure 2.1, and the hardware setup is shown in Figure 2.2.

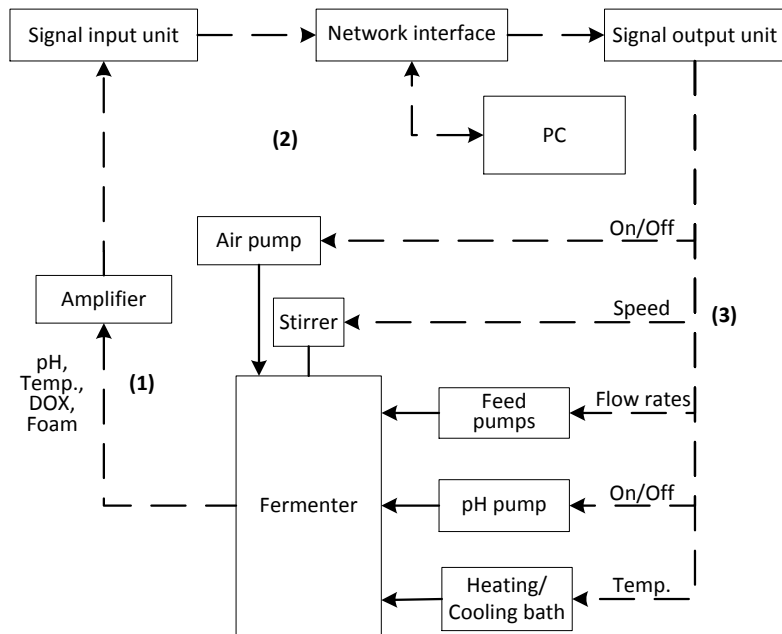

Figure 2.1: **The schematics/design of signal processing in a bioreactor.** Dashed lines represent the signals while continuous lines correspond to physical connections, i.e. pipes. Signals from sensors are amplified and sent to the PC (1). The PC displays the values and calculates corresponding output signals (2). The output signals are sent to the different hardware components (3).



is essential to convert the lactone form of lovastatin into an acidic form, which is produced in excess in fermentation. The (+)-geodin and sulochrin standard was purchased from Sapphire Bioscience (Sydney, Australia). Sulochrin, (+)-geodin and lovastatin appeared at a retention time of around 4, 7 and 10 minutes, respectively, in the HPLC chromatogram.

#### **2.5.1.1 Optimisation of HPLC analysis**

To simplify the analysis of all the metabolites, a standard method that can simultaneously detect all three metabolites of interest at the same time was developed. It is important to minimise the time required to analyse each sample and reduce the preparation time due to the sensitivity of the sample to alteration in temperature. Using the optimised method (refer to Materials and Methods: Section 2.5.1), we successfully identify each of the metabolites of interest under similar conditions. To measure the concentration of the intended metabolites in the samples, standard curves were generated by performing serial dilutions of the standards, as shown in Figure 2.3. The peaks of interest are depicted in Figure 2.4.

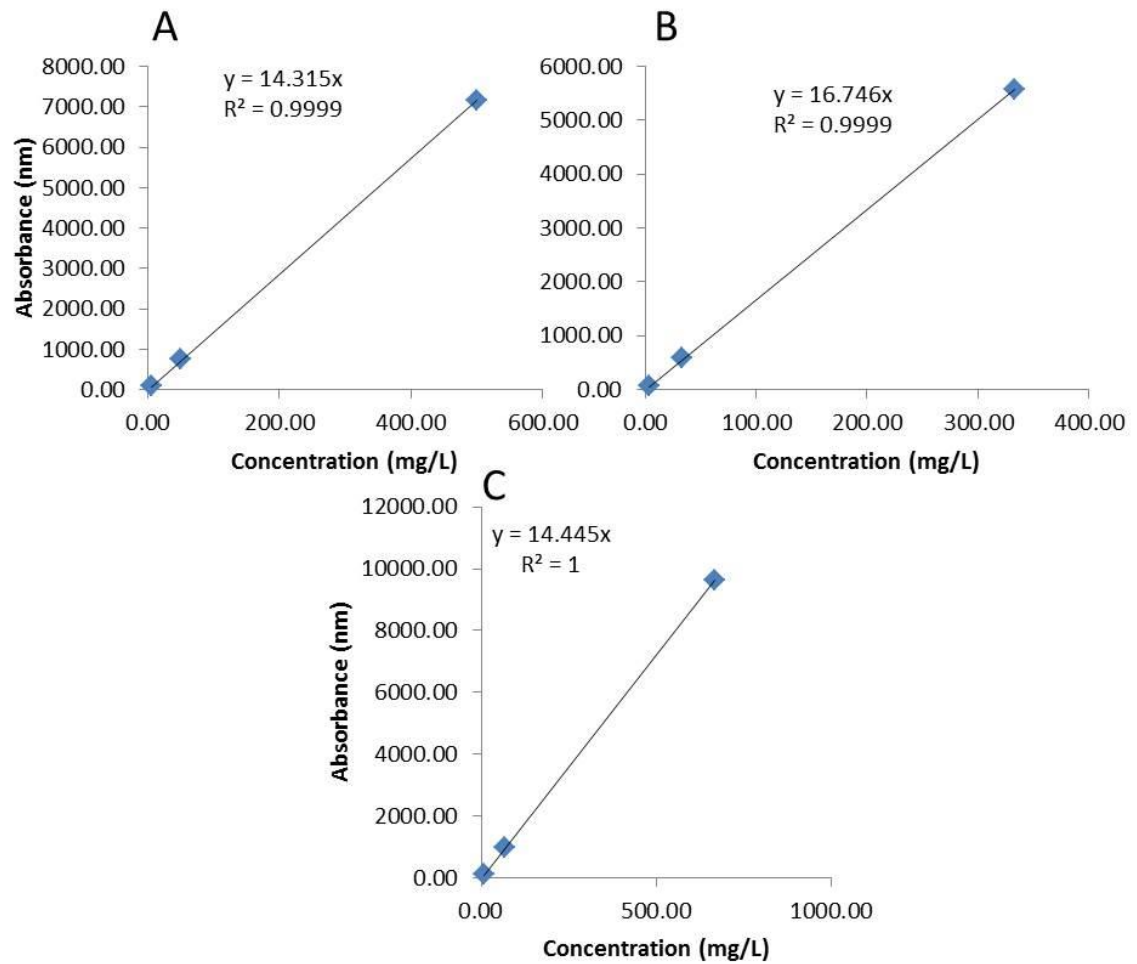

Figure 2.3: **The standard curves of three metabolites produced by *A. terreus*.** A) Lovastatin, B) (+)-geodin and C) sulochrin. These metabolites are analysed using HPLC under similar conditions.



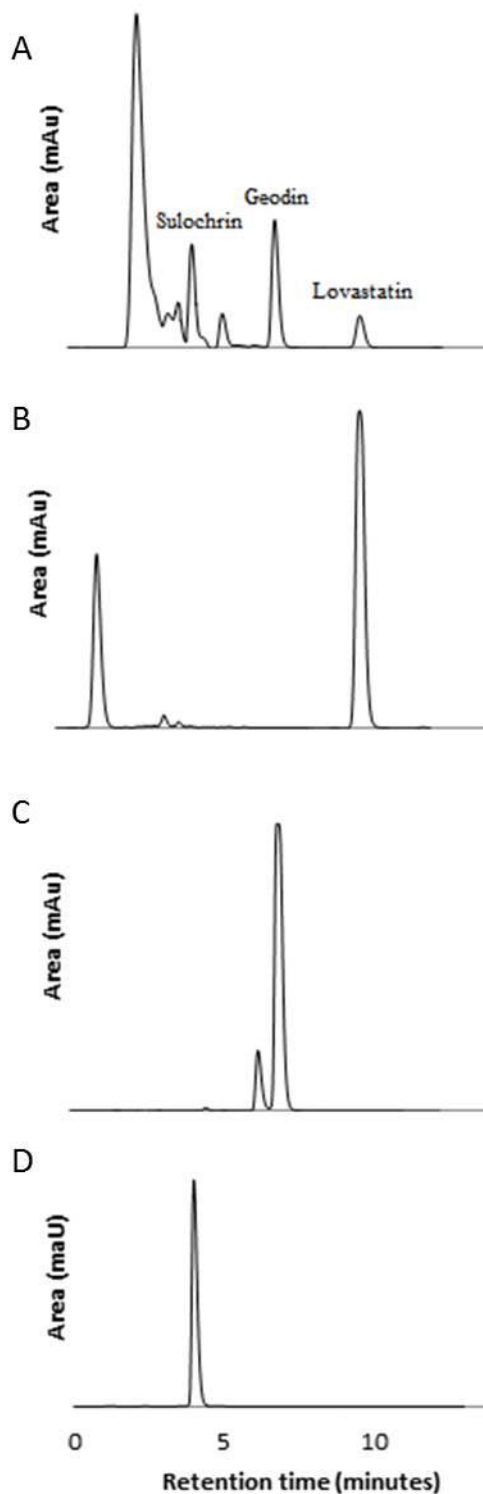

Figure 2.4: **The peaks of lovastatin, (+)-geodin and sulochrin in HPLC chromatogram.** The peaks can be easily identified in the untreated sample of fermentation. Note that lovastatin and (+)-geodin would break down into additional compounds over time, as shown in the (B) and (C). Sulochrin (D) was shown to be more stable as no breakdown was observed even after 3 months in the storage. The original and control chromatograms are available in the appendix section.

As the lovastatin tablet was manufactured by pharmaceutical company, their lovastatin content is in the form of lactone as this form is more stable and readily convertible to hydroxyacid (active) form upon entering the human gastric juice. Using the previously described treatment (refer to section 2.5.1), HPLC analysis showed that no lactone form was detected, as all of them was successfully converted to the hydroxyacid form. Although the analysis of Yang DJ et al. showed the formation of lovastatin methyl ester when this method is used, our analysis did not show any presence of this compound (Figure 2.4) and in control chromatogram (in Appendix) [69]. The peak produced was a single, clean peak at a retention time of around  $10 \pm 1$  minutes (which could change slightly over time due to the age of the column or inaccurate mobile phases mixture). Our findings are in agreement with a few other authors [49,60]. Our treatment was also shown to produce a stable hydroxyacid solution for a few months at 4 °C. However, fresh solution or standard is recommended to be prepared every three months as our analysis showed the breakdown of lovastatin to an unidentified compound, which is possibly its methyl ester form as shown in Figure 2.4.

No further modification was performed on (+)-geodin and sulochrin sample, apart from the addition of 100% methanol. Clean peaks at retention time of  $4 \pm 0.5$  minutes (sulochrin) and  $6 \pm 0.5$  minutes (+)-geodin) were detected (Figure 2.4). Both of these standards were shown to be only stable to be stored in -20°C. Hence the analysis of fermentation sample was done rapidly to avoid the loss of this metabolite. Subsequent analysis showed that (+)-geodin can break down to the unidentified compound after three months, while sulochrin is still stable. In terms of fermentation sample, no further treatment was shown to be needed for the samples in preparation for the HPLC analysis. HPLC peaks produced from all three metabolites were non-overlapping (including with unknown peaks in fermentation), and distinct from each other.

### 2.5.2 Glycerol calorimetric detection

Quantification of glycerol in the samples was done using glycerol calorimetric detection reagent purchased from Sigma-Aldrich (Sydney, Australia). This reagent measures glycerol by using enzymatic reaction:

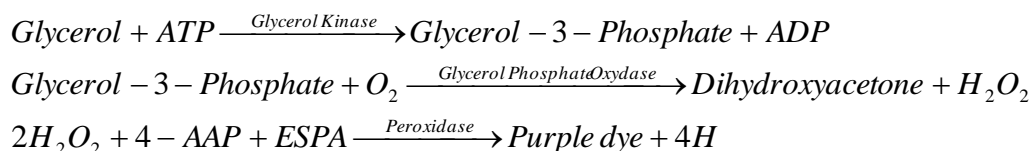

Glycerol is phosphorylated to glycerol-3-phosphate by glycerol kinase, followed by oxidation reaction by the glycerol phosphate oxidase. The resultant hydrogen peroxide is catalysed by peroxidase to produce a brilliant purple colour that can be detected by an absorbance at 540 nm.

The reagent can be stored at 4°C away from light for a few months after dilution with miliQ water, provided that no change of colour (pale yellow) or cloudy solution is formed. The reagent must also be equilibrated to room temperature before the assay.

There is no general amount of the reagent that needs to be added to the samples, as long as sufficient colour is developed to be detected by spectrophotometer. In our case, 90 µL of reagent solution is added to 10 µL of samples or standards in a 96-well plate. The plate is gently shaken for a few seconds to mix and left for 15 minutes at room temperature to react. As the detection is very sensitive, the acceptable range of glycerol concentration is around 20 mg/L. The plate was read using a microplate reader (Biorad Model 680) at 450 nm.

### **2.5.3 Inductively coupled plasma mass spectrometry (ICP)**

Quantification of heavy metals was performed using Varian inductively coupled plasma mass spectrometry (ICP-OES Model 720) using the mixture of heavy metal standards (Sigma-Aldrich). All the elements that were tested are depicted in appendices. The samples were filtered through 0.22  $\mu\text{m}$  filter before application. Minimum of 5 mL is required for each sample injection with a typical concentration of 5, 10 and 20 parts per million (ppm).

### **2.5.4 Carbohydrate determination**

Carbohydrate concentration in this experiment was determined using another calorimetric method, which is phenol-sulfuric acid assay [70]. Both phenol and concentrated sulphuric acid were obtained from Sigma-Aldrich (Sydney, Australia). When carbohydrates are treated using strong acids, they will be converted into furfural and its homolog by oxidation, reduction and condensation processes. These compounds will then react with organic compounds such as phenol to form specific colours.

Similar to glycerol detection, there is no general rule on how much sample of reagent needed, as long as the colour developed is enough to be detected by spectrophotometer. In our case, using a 96-well plate, 50  $\mu\text{L}$  of the sample was rapidly added to 150  $\mu\text{L}$  of concentrated sulphuric acid, followed by 30  $\mu\text{L}$  of 5% phenol. The mixture was then incubated for 10 minutes 90°C in the incubator. Finally, the colour change was measured using a microplate reader (Biorad Model 680) at 490 nm.

## **2.6 Characterisation of metabolic expression profiles using RT-PCR**

### **2.6.1 Isolation of total cellular RNA**

Prior to the extraction, the fungus pellet was freeze-dried using Alpha 1-2 LDplus freeze dryer (Fisher Bioblock Scientific, Germany) to obtain a fine powder form as part of the fungus homogenisation process of the fungus. The extraction of fungal isolates was performed using ISOLATE II RNA Plant Kit purchased from Bioline (Sydney, Australia). To assist in the cell lysis, 350  $\mu$ L of Lysis Buffer RLY and 3.5  $\mu$ L  $\beta$ -ME was added to 100 mg of fungal sample and sample was vortex vigorously. Later, the mixture of the reagents and samples were filtered using the specific filter provided with spinning the tube for 1 minute at 11000g. The filtrate was transferred to a clean, sterile tube, and 350  $\mu$ L of 70% ethanol was added to the filtrate by pipetting up and down for a few times. The filtrate then was trapped in a special filter provided with the kit by centrifuging the filtrate for 30 seconds. The resultant lysate was discarded. The filter that contains the RNA transcripts was then transferred into a new tube, and 350  $\mu$ L of Membrane Desalting Buffer was added on top of it. The filter was then centrifuged at 11000g for 1 minute to dry the membrane. To digest unwanted DNA, 95  $\mu$ L of DNase I enzyme was added directly onto the center of silica membrane, and was left at room temperature for 15 minutes. The silica membrane was then washed by using Wash Buffer RW1 and RW2 before transferring into fresh nuclease-free 1.5 mL collection tube. Finally, the RNA can be collected by adding 60  $\mu$ L RNase-free water on top the membrane, followed by centrifugation at 11000g for 1 minute. The concentration of the isolated RNA was measured using a NanoPhotometer<sup>TM</sup> (Implen GmbH, Munich, Germany). Samples were stored at -80°C until use.

### 2.6.2 Synthesis of complementary DNA (cDNA) from RNA

Complementary DNA (cDNA) was prepared following total RNA isolation using Tetro cDNA Synthesis Kit (Bioline, Sydney, Australia). All the solutions were briefly vortex and centrifuged before use. The priming premix should be prepared in RNase-free reaction tube on ice using the guideline of Table 2.1:

Reagents	Volume
Total RNA (up to 5 µg)	5 µL
Primer Oligo dT	1 µL
10 mM dNTP mix	1 µL
5x RT buffer	4 µL
Ribosafe RNase inhibitor	1 µL
Tetro reverse transcriptase	1 µL
DEPC treated water	7 µL

Table 2.1: **The combination of sample and reagents for the synthesis of cDNA.**

The samples were then placed into a Biorad T100 Gradient Thermal Cycler (NSW, Australia). The RT program consisted of incubation at 45 °C for 30 minutes, the termination reaction at 85°C for 5 minutes, before being cooled briefly on ice for a few minutes. A no RNA RT sample was prepared for each experiment, where DEPC.H<sub>2</sub>O was substituted for RNA, to act as a negative control for the RT-PCR procedure. Immediately following the reverse transcription, cDNA was diluted 1 in 5 by the addition of 80µL of DEPC.H<sub>2</sub>O and then stored at -80°C until use. Analysis of the integrity of products was performed by running 10 µL PCR product with 2 µL 10X blue juice gel loading buffer (Life Technologies) on 1% agarose gel for 30 minutes at 75

volts. The products were visualised using ethidium bromide under UV light. The size of the PCR products was determined according to the molecular ladder (Biolone, Sydney, Australia).

### **2.6.3 Real-time polymerase chain reaction (RT-PCR) for quantification of *lovB* levels**

The expression of the gene of interest was analysed using the SYBR green method of detection. Amplification of cDNA was performed using 1  $\mu\text{L}$  of 1 in 5 diluted cDNA, 0.8  $\mu\text{L}$  of both forward and reverse primer (determined following primer optimisation, shown in Appendix), 4  $\mu\text{L}$  of cDNA was combined with 10  $\mu\text{L}$  of 2x SensiFast SYBR No-Rox One-Step Mix, 0.2  $\mu\text{L}$  reverse transcriptase, 0.4  $\mu\text{L}$  RiboSafe RNase Inhibitor and 3.8  $\mu\text{L}$  of DEPC-treated water to the final volume of 20  $\mu\text{L}$ , as depicted in Table 2.2. Each sample was prepared in triplicate, and the no RNA RT was used as a negative control to ensure no nucleic acid contamination was present in any reagents used through the procedures.

<b>Reagent</b>	<b>Volume</b>
2x SensiFast SYBR No-Rox	10 $\mu$ L
One-Step Mix	
10 $\mu$ M Forward primer	0.8 $\mu$ L
10 $\mu$ M Reverse primer	0.8 $\mu$ L
Reverse transcriptase	0.2 $\mu$ L
RiboSafe RNase Inhibitor	0.4 $\mu$ L
DEPC-treated water	3.8 $\mu$ L
Template (cDNA)	4 $\mu$ L
Total	20 $\mu$ L

Table 2.2: **The amount of each reagent used in RT-PCR.**

Samples were cycled in the Rotor-Gene<sup>TM</sup> 6000 and analysed using Rotor-Gene<sup>TM</sup> Series 1.7 software. The PCR procedure consisted of incubation at 45°C for 10 minutes, 95°C for 2 minutes followed by 40 cycles of 95°C for 5 seconds (denaturing), 60°C for 10 seconds (annealing) and 72°C for 5 seconds (elongation). Fluorescence readings were recorded on the SYBR channel on the completion of each 72°C cycle. Specificity of amplification was confirmed by the generation of a melt curve following each PCR procedure, where a single amplification peak indicated a single PCR product (in appendix). Details of the primers utilised in this study are listed in Appendices. All primers were purchased from Sigma-Aldrich (Sydney, Australia). The endogenous reference gene  $\beta$ -actin was used to normalize cycle threshold (C<sub>t</sub>) data obtained from the genes investigated. The relative expression of the target genes in the studied samples was obtained using the difference in the comparative C<sub>t</sub> ( $\Delta$ C<sub>t</sub>) method. For each sample, a value for threshold (C<sub>t</sub>) was determined, defined as the mean cycle at which the



fluorescence curve reached an arbitrary threshold. The  $\Delta C_t$  for each sample was then calculated according to the formula  $C_t$  target gene -  $C_t$   $\beta$ -actin. Finally, relative levels of expression of the target genes in the studied samples as compared with the reference sample were calculated as  $2^{-\Delta C_t}$ .

## 2.7 Microscopy

For the general characterisation of the pellet morphology, the images of the fungus pellet were taken by using Digital Blue QX7 Computer Optical Microscope (Digital Blue, Atlanta, USA).

For the detailed viewing of much smaller fungus spore, Scanning Electron Microscope (SEM) was used (Hitachi S4500 FEG-SEM). Before the SEM was used, the samples were prepared and mounted on the special thermanox coverslip (ProSciTech, QLD, Australia). The coverslip was treated with a special cell-adhering solution (1% polyethylenimine) to ensure the spores will stick to its surface. The coverslips were briefly rinse with 90% acetone, followed by a wash with Milli-Q water before being incubated at least for 60 minutes in 1% PEI solution. The coverslips then were rinsed twice with Milli-Q water and dried in the oven at 60 C for 10 minutes.

When the coverslips are ready, the spores were adhered to its surface by adding sufficient liquid spore solution on the coated side of the coverslips. After 30 minutes of incubation, the spore's solution can be discarded, and primary fixative (2.5% glutaraldehyde) was added for at least 1 hour. After the primary fixative was discarded, secondary fixative (1% osmium tetroxide in 0.1M PBS) was added and incubated for 1 hour. The specimen coverslips were washed three times with Milli-Q water for five minutes each before the procedure of dehydration series can be performed.

The dehydration steps involved several washing procedures using increasing concentration of ethanol to remove the trace of water in the sample. In short, the washing involved the immersion of coverslips in different ethanol concentration (30%, 50%, 70%, 95% and 100%), for 30 minutes each. The coverslips then were treated with

an hexamethyldisilazane (HDMS) solution for two minutes and the samples were put in a desiccator with the lid off to allow the HDMS fumes to evaporate overnight. Finally, the coverslips can be mounted on stubs and coated with gold for viewing.

## **2.8 Statistical analysis**

All experiments were conducted in a minimum of triplicates, except for the bioreactor study. Data obtained for metabolite production involving lovastatin, (+)-geodin and sulochrin were analysed using one-way ANOVA with Tukey post hoc test. The results are considered significant when  $p < 0.05$ . All statistical analysis was performed using GraphPad Prism, version 6.01. For the plotting of the graph, 95% confidence interval was used for the error bar.

## Chapter 3 - Optimisation of media condition

### 3.0 Introduction

Optimal production of metabolites by fungi or any microbes is dependent on the composition of culture media. A standard medium for the cultivation of *A. terreus* ATCC 20542 has not yet been described. However, the medium is normally comprised of carbon source (s), nitrogen source (s), water, salts and micronutrients (as discussed in the introduction section).

It is generally accepted that a nitrogen-deficient culture medium favours the growth and metabolite production of *A. terreus*. The majority of studies suggest that complex nitrogen sources are better for the growth of *A. terreus* [34,37,49,51,53]. It was suggested that these complex nitrogen sources are only utilised by fungi because of the lack of ammonium ion [43]. However, in another study, the use of nitrates and ammonium as nitrogen source failed to produce any lovastatin [37]. Therefore, this study aimed to determine the optimal nitrogen sources, both for growth and metabolite production of the *A. terreus*.

By contrast, the most suitable carbon source for optimal metabolite production varies in the literature and is largely dependent on the cultivation method. For example, some studies reported that slowly-metabolised carbons are better for metabolite production [37,49,54]. However, a few other studies showed a good metabolite production using fast-metabolised carbons, such as fructose and glucose [50,51]. We hypothesised that the rate of carbon being metabolised does not affect the production of metabolites. In this study, a range of carbon sources were used to determine whether the production of metabolites is dependent on the rate of carbon consumption.

The optimisation of basal salt condition and its possible physiological effect on the fungal pellet will also be investigated. The effect of salt can be either ion-specific [55] or osmotic-based [71]. As there are multiple basal salt formulae in the literature, an optimal salt medium (in relative to the type of carbon and nitrogen used in this experiment) will be investigated, and subsequently be used in all the incoming investigations.

The pre-culture condition may also influence microbial growth and metabolite production. According to Bizukojc et al. (2009), pre-culture for *A. terreus* is important to speed up the stationary phase into metabolite production phase [60]. During pre-culture, an optimal ratio of nitrogen and carbon is required; and this may differ from the main culture medium. The optimal spore conditions, such as spore age and spore amount, are also essential for the pre-culture to thrive [35].

This chapter aimed to investigate the effects of different carbon and nitrogen sources, carbon/nitrogen ratio, salt types and pre-culture conditions on the production of lovastatin, (+)-geodin and sulochrin. At the same time, the morphology of the fungus was also analysed. The data from this chapter was used as a basis for the proceeding chapter: Cultivation of *A. terreus* in Crude Glycerol.

### **3.1 The effect of salts interactions on the production of lovastatin**

Salt is an essential component of the culture media. Besides providing additional nutrients in the form of the metal ions, it is also essential for the regulation of osmotic pressure in a microorganism. In our investigation, we tried to minimise the use of salt as a means to limit the interaction of salts with the fungal strain, therefore reducing the false-positive results. The use of the salts in this experiment is depicted in Table 3.1 and were pre-determined by referring to the previous literature [55,72,73].

$\text{MnSO}_4 \cdot 5\text{H}_2\text{O}$ ,  $\text{CuSO}_4 \cdot 5\text{H}_2\text{O}$  and  $\text{FeCl}_3 \cdot 6\text{H}_2\text{O}$  formed crystal deposits in the solution when all the salts were combined and heated together in an autoclave at  $121^\circ\text{C}$  for 15 minutes under high pressure. Their exclusion from the media was shown to improve lovastatin production by more than two-fold. The addition of  $\text{CaCl}_2 \cdot 2\text{H}_2\text{O}$  in the media produced no significant change in lovastatin production; hence it was also excluded (Table 3.1). Other salts, such as  $\text{KH}_2\text{PO}_4$ ,  $\text{MgSO}_4 \cdot 7\text{H}_2\text{O}$ ,  $\text{NaCl}$  and  $\text{ZnSO}_4 \cdot 7\text{H}_2\text{O}$  were shown to be important as their absence would reduce lovastatin production (Table 3.1). No-salt negative control showed a considerable reduction of lovastatin production compared to the highest lovastatin produced (17.5% lower). In all the experiments performed, the biomass did not differ significantly between different treatments.

Based on these initial results, we optimised the amount of  $\text{KH}_2\text{PO}_4$ ,  $\text{MgSO}_4 \cdot 7\text{H}_2\text{O}$  and  $\text{NaCl}$  using a full factorial design (3 levels), as depicted in Table 3.2. As shown in Table 3.2, the optimal amount of  $\text{KH}_2\text{PO}_4$  and  $\text{NaCl}$  is 0.4 g/L, and  $\text{MgSO}_4 \cdot 7\text{H}_2\text{O}$  is at 0.2 g/L.



Set	KH <sub>2</sub> PO <sub>4</sub> (mg/L)	MgSO <sub>4</sub> •7H <sub>2</sub> O (mg/L)	NaCl (mg/L)	Lovastatin (mg/L)
1	0.4	0.2	0.1	7.84 ± 1.05
2	0.1	0.1	0.1	6.15 ± 0.45
3	0.1	0.4	0.2	6.04 ± 0.87
4	0.1	0.2	0.2	7.67 ± 0.94
5	0.1	0.1	0.4	7.55 ± 1.34
6	0.4	0.1	0.1	7.32 ± 1.15
7	0.2	0.2	0.2	7.75 ± 0.73
8	0.2	0.2	0.4	7.91 ± 1.36
9	0.4	0.2	0.2	7.96 ± 1.01
10	0.2	0.4	0.1	6.32 ± 0.66
11	0.2	0.1	0.4	7.18 ± 0.69
12	0.1	0.1	0.2	6.25 ± 1.12
13	0.4	0.4	0.1	6.68 ± 0.83
14	0.4	0.1	0.4	9.05 ± 1.47
15	0.2	0.4	0.2	6.91 ± 0.79
16	0.2	0.1	0.1	7.17 ± 1.25
17	0.1	0.4	0.4	6.67 ± 0.94
18	0.1	0.2	0.4	7.62 ± 1.38
19	0.4	0.4	0.2	6.59 ± 0.53
20	0.4	0.2	0.4	9.96 ± 1.63
21	0.4	0.1	0.2	7.27 ± 1.14
22	0.4	0.4	0.4	7.56 ± 0.87
23	0.1	0.4	0.1	6.05 ± 0.48
24	0.2	0.4	0.4	7.39 ± 1.04
25	0.2	0.2	0.1	7.34 ± 1.07
26	0.1	0.2	0.1	6.13 ± 0.91
27	0.2	0.1	0.2	7.03 ± 0.79

Table 3.2: **Optimization of the amount of three chosen salts (KH<sub>2</sub>PO<sub>4</sub>, MgSO<sub>4</sub>•7H<sub>2</sub>O and NaCl) on lovastatin production, using 3-level factorial design).**

95% confidence was used as the standard error.



### 3.2 Nitrogen sources

As previously discussed in the introduction section, nitrogen source is one of the major components in the fermentation media, and complex nitrogen sources are usually preferred in the cultivation of *A. terreus* [34,37,49].

In this investigation, this theory was revisited and tested using selected nitrogen sources at 4 g/L each, according to Bizukoje et al. recommendation [53]. We opted to use ammonium sulphate (AS), as a simple and an easily reproducible nitrogen source; and several complex nitrogen sources, namely powdered soybean (SB), yeast extract (YE) and flour. Figure 3.1 summarises the production of lovastatin, (+)-geodin and sulochrin by *A. terreus* under the influence of different nitrogen sources over the period of 12 days. From our findings, it is clear that the use of AS is not favourable for metabolite production, as significant reduction was observed across all three metabolites tested. This reduction was also observed by Hajjaj et al. [37], who observed no lovastatin production when ammonium ion was used as the main nitrogen source. However, they also observed that *A. terreus* primarily utilised ammonium ion for growth, which was the opposite with our finding. We found that the cultivation of *A. terreus* in AS produced significantly smaller and lighter pellet, with a soft, jelly-like appearance as compared to other nitrogen sources. This result indicates that apart from inhibiting metabolite production, the application of ammonium ion is also unsuitable for the growth of *A. terreus*. So far, the main reason why this happened is still unknown, as most microorganisms can readily assimilate ammonium ion for their growth. However, upon further investigation, it was observed that the use of ammonium ion acidifies the media (pH 4.1), which might be not conducive for *A. terreus*. It is possible that the application of simple nitrogen sources that do not acidify the media would result in better metabolite production.

The use of complex nitrogen sources showed better production of lovastatin, (+)-geodin and sulochrin, without acidification of the media (all produced  $\text{pH} > 6$ ). While the production of lovastatin showed significant improvement, a larger spike in production can be observed in (+)-geodin and sulochrin. The pattern of production of (+)-geodin and sulochrin was also highly similar (as they are also being produced in the same pathway), which may indicate that their production is influenced by the same factor. SB was shown to be the best nitrogen sources for both metabolites, followed by YE and flour. Although the main reason is unclear, Bizukojc M. et al. (2011) proposed that (+)-geodin's production is reduced in the presence of nitrogen [74]. It is possible that SB is utilised more rapidly than the other nitrogen sources, which leads to the increase of (+)-geodin and sulochrin in the broth. Further analysis of nitrogen consumption profile would be beneficial for the confirmation of the theory.

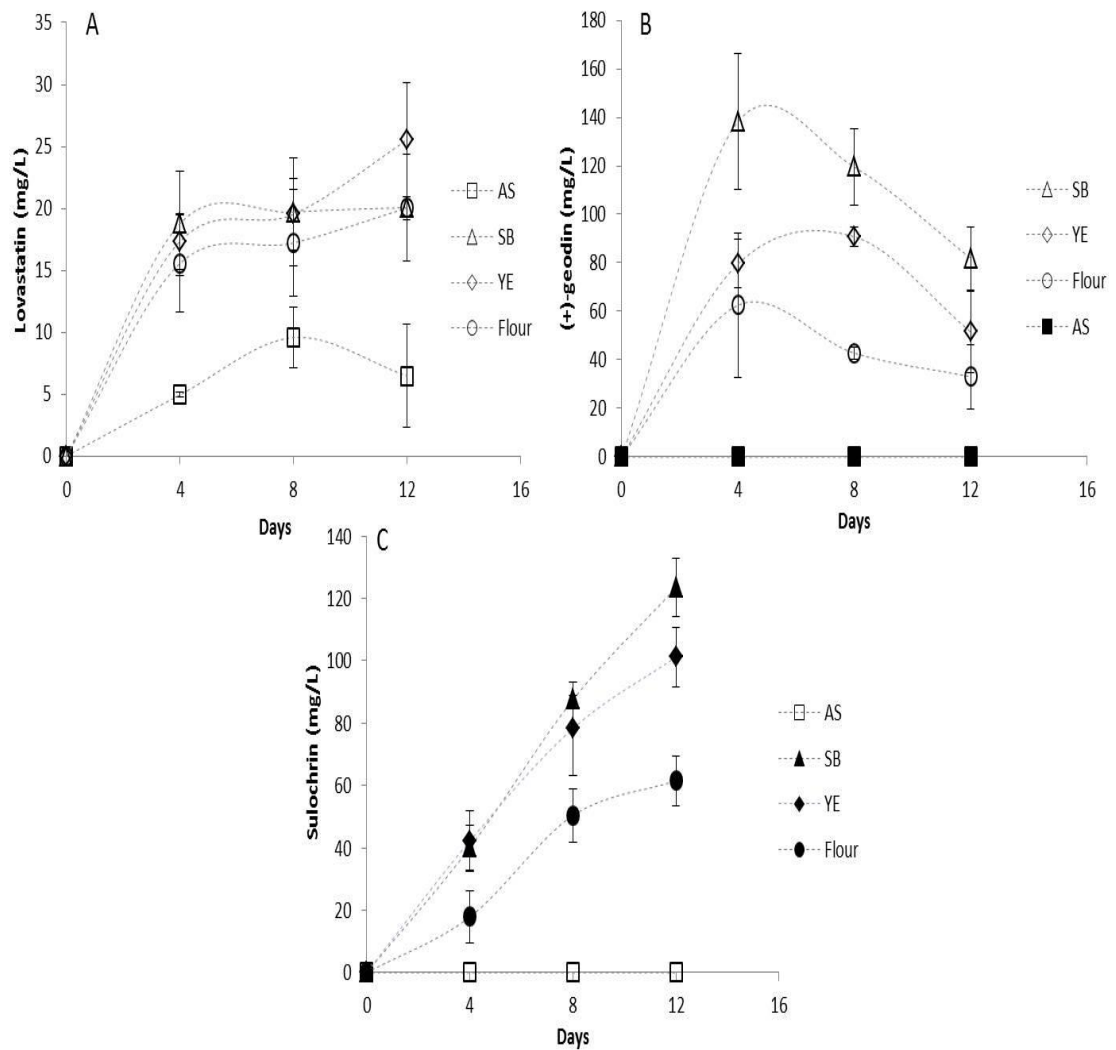

**Figure 3.1: Lovastatin, (+)-geodin, and sulochrin production over the period of 12 days.** Lovastatin, (+)-geodin and sulochrin production of ammonium sulphate (AS) were significantly lower than other nitrogen sources. A) Lovastatin production levelled off after day 4 in all treatments. B) Reduction of (+)-geodin's production was observed only after day 8, while in C) sulochrin's production was still continuing even after day 12. Symbols show experimental values while dashed lines connecting symbols are used as a visual guide only.

### 3.3 Pre-culture

Pre-culture is a preliminary culture that prepares the microorganisms for production culture. Pre-culture for *A. terreus* is essential to provide sufficient nutrients and shorten the time of cultivation. In this section, we tested the effect of pre-culture and the optimal concentration of nitrogen sources (yeast extract) needed for the pre-culture. The amount of carbon (lactose) for all the treatments was constant at 10 g/L (with 8 g/L YE), except for the control at 20 g/L (with 4 g/L YE). After 24 hours, the fungal pellet was transferred into culture media (20 g/L lactose and 4 g/L YE) for 5 days to measure its effect on lovastatin production. The summary of the experiment and results are shown in Table 3.3.

In our investigation, the optimal YE (as nitrogen source) for pre-treatment was at 8 g/L as it produced high amount of lovastatin (12.33 mg/L), although it did not produce the highest biomass or the diameter of the fungal pellet. In a previous investigation, it has been found that biomass growth of *A. terreus* is not directly related to lovastatin production [53]. Similarly, the bigger pellet diameter may also reduce its production [43]. However, this relationship was not investigated further. The usage of 4 g/L YE showed significantly lower growth and smaller pellet, which translated into lower lovastatin production (7.96 mg/L). In contrast, the usage of 12 g/L of YE produced significantly larger pellet and larger biomass, with low lovastatin production.

<b>Treatment</b>	<b>Biomass (g/L)</b>	<b>Lovastatin (mg/L)</b>	<b>Diameter (mm)</b>
0 g/L YE	1.69	3.19	0.40
4 g/L YE	6.18	7.96	1.11
8 g/L YE	7.51	12.33	2.05
12 g/L YE	10.83	9.12	2.51
Control	5.10	6.54	1.46

Table 3.3: **The effect of nitrogen source (yeast extract) concentration on growth, metabolite production, and diameter of *A. terreus*.** Control experiment consisted of higher carbon source (lactose) at 20 g/L. The production of lovastatin and biomass were significantly different between treatments. The diameter was taken 24 hours after cultivation while biomass and lovastatin were measured at the end of 5-days cultivation

Spore factor, which is another key feature in pre-culture media, was investigated next. As mentioned in the introduction, there were three different hypotheses on the formation of the pellet from spores. Figure 3.2 from scanning electron microscope suggests that it is likely that the formation of pellet arises from the aggregate of multiple spores. The main factors studied in this work were the spore amount and age, as shown in Figure 3.3. The importance of spore factors had been demonstrated numerous times in other studies [43,75]. Our observations showed that while spore amount affected the production of all three metabolites, the difference in production was only significant when the spore amount was increased from  $10^5$  to  $10^7$  spore/L, but not from  $10^7$  to  $10^9$

spores/L. It could be that high spore amount would reduce the pellet diameter, which contributed to the higher lovastatin production, which was also observed in another study [43]. It is currently unknown why (+)-geodin and sulochrin reacted negatively to the increase of spore amount. It is most likely that higher spore would reduce the oxygen content in the media, which is essential for the formation of these metabolites. Therefore,  $10^7$  spores/L was chosen as the spore amount to be used in the future experiments, as the adequate production of lovastatin, (+)-geodin and sulochrin was observed at this particular spore amount.  $10^9$  spores/L was not chosen as it produced very high biomass, which increases the complexity of transferring the fungus pellet into new cultivation media, coupled with low production of (+)-geodin and sulochrin.

A similar conclusion can be made involving spore age. Spore age is measured based on how long the fungus was grown on the solid media i.e. PDA plate before harvested into suspension. Higher spore age produces higher metabolites but was not significant in value from one point to the other. A significant change in metabolite production was observed only when the concentration of spores was increased from  $10^5$  to  $10^9$  spores/L (two-point increase). This is supported by images taken from an electron microscope, which found no difference in term of spore morphology at day 5, 7 and 9 (Figure 3.4). Considering 7 days of culture is more feasible in term of experimental design, this time point was chosen for all the experiments.

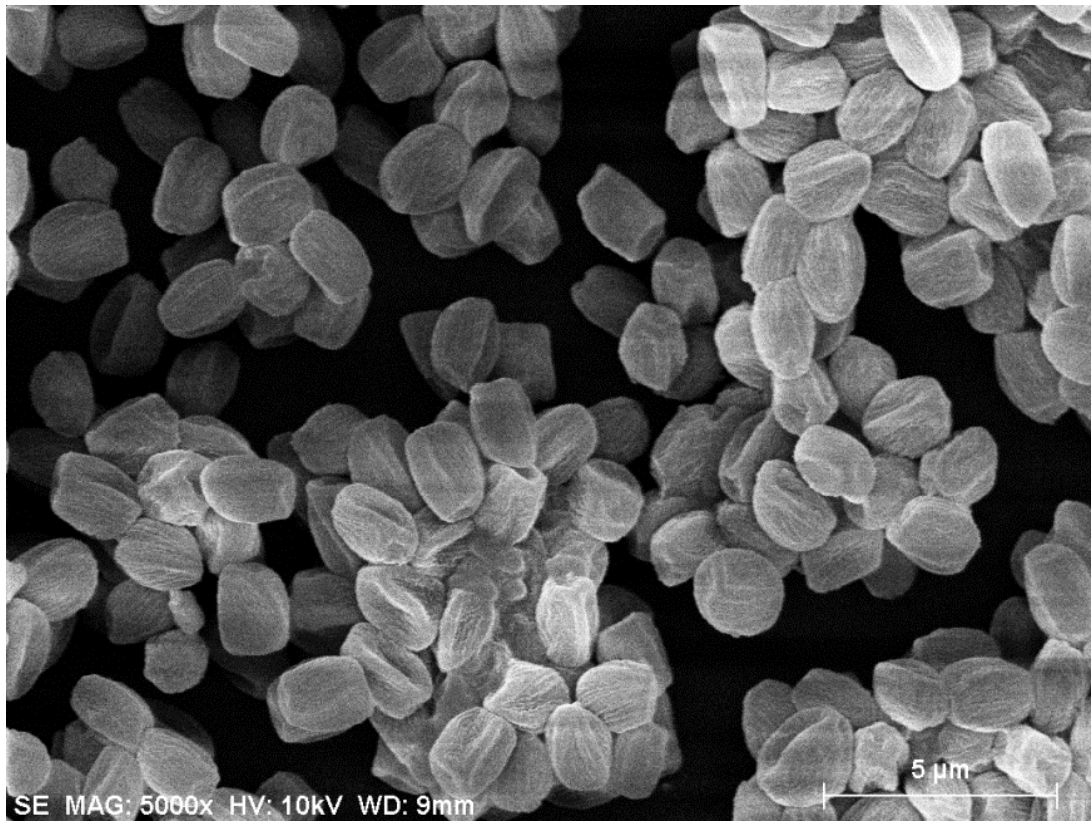

Figure 3.2: **The scanning electron microscope image of *A. terreus* spores under 5000 times magnification.** An aggregate of spores was observed after 4 hours post-inoculation, which suggests that the rise of the single pellet is resulted from the combination of multiple spores.

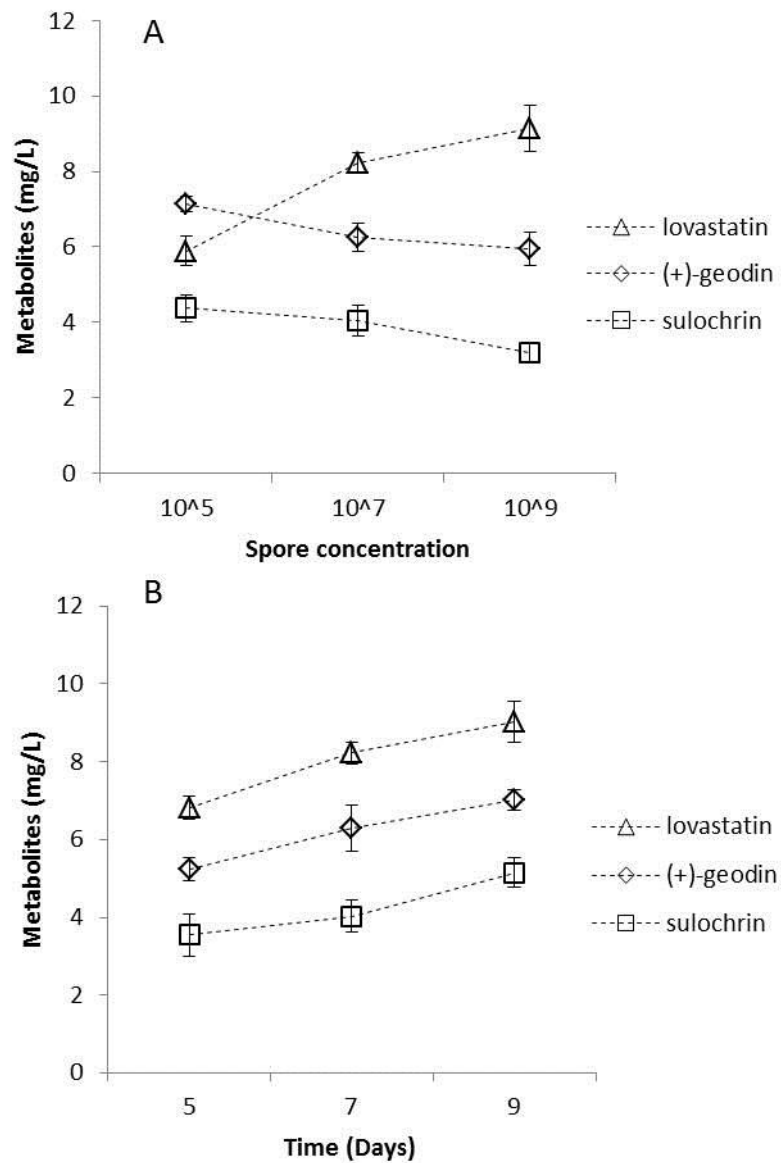

Figure 3.3: **The investigation of spore factors on the production of metabolites by *A. terreus*.** A) Non-significant change of metabolite production was observed when different spore amount was used. B) Increasing spore age also had minimal improvement on metabolite production.



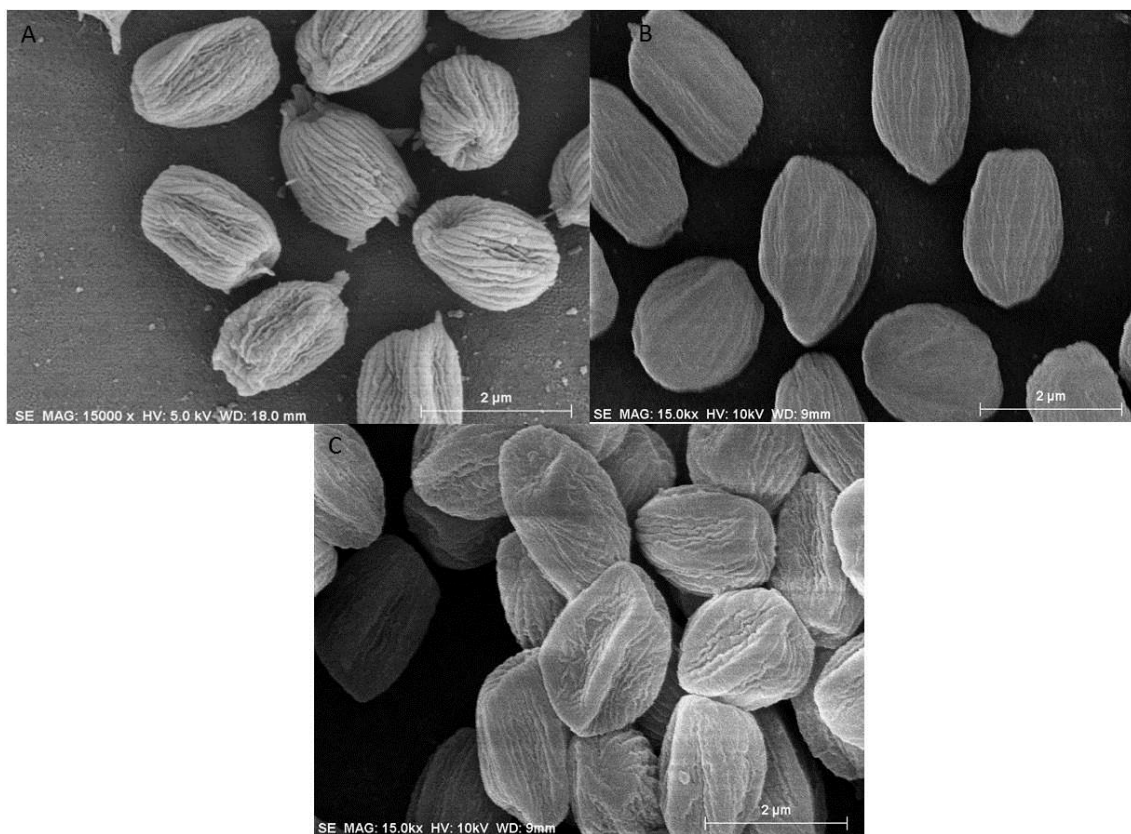

Figure 3.4: The example of scanning electron microscope image of *A. terreus* spore taken from the spore stock under 15000 times magnification. No differences in size or morphology were observed at A) 5 days B) 7 days and C) 9 days.

### **3.4 Carbon source**

#### **3.4.1 The relationship between lovastatin, biomass and morphology production of *A. terreus* under different carbohydrate treatments**

The present study investigated the effects of different sources of carbon in the form of carbohydrates, comprising of monosaccharides (D-glucose, D-xylose, D-fructose, D-galactose, D-mannose, D-ribose, D-arabinose) and disaccharides ( $\alpha$ -lactose, maltose, D-sucrose), on the cultivation of *A. terreus* (Figure 3.5).

Morphology of fungus is one of the key factors that influence the production of metabolites. The submerged pellet form is known to produce a higher production of lovastatin when compared to filamentous fungus [33,34]. Therefore the pellets were used for the experiment. The experiment involving different carbohydrates began with the pre-culture media. Figure 3.6 showed little differences in fungus morphology in the presence of different carbohydrates in the pre-culture media. It is most likely that the immature form of the fungus would not exhibit any morphological differences, as a means of maximising nutrient uptake through the filament. This highly filamentous pellet structure persisted even until 24 hours when a visible pellet has already formed. Spherical, round pellets with different hair characteristics can only be observed after 48 hours of culture. Figure 3.7 shows the three main pellet morphologies observed following treatments after the end of cultivation, which served as our point of reference throughout the discussion.

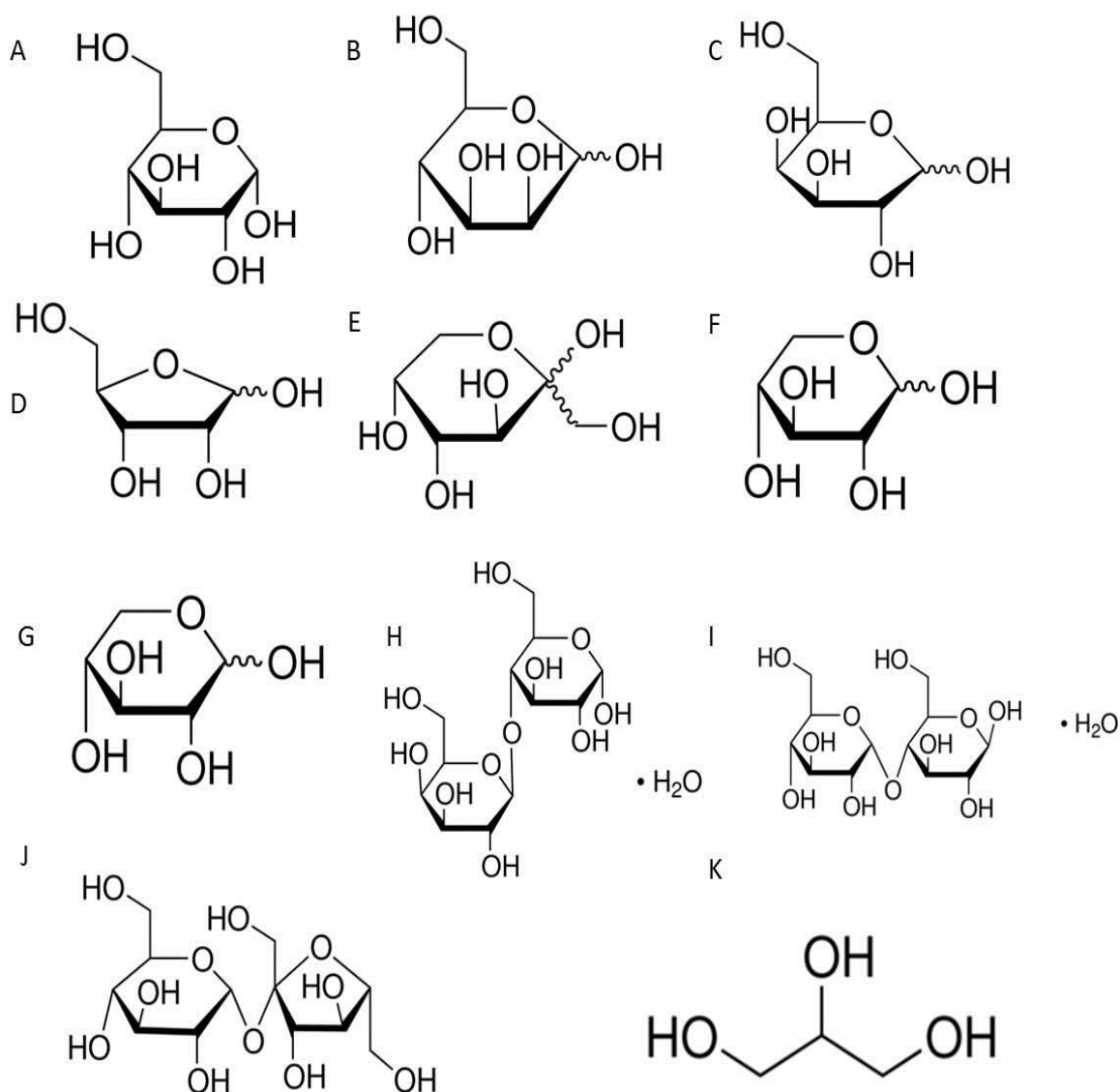

Figure 3.5: **Different structures of monosaccharides and disaccharides used in this study.** Carbohydrate structures have been shown to influence how carbon is taken and metabolised by several microorganisms [76,77]. From top left: A) D-glucose B) D-mannose C) D-galactose D) D-ribose E) D-fructose F) D-arabinose G) D-xylose H)  $\alpha$ -lactose I) D-maltose J) D-sucrose. In K), the structure is glycerol, which will be used as a control in this experiment.

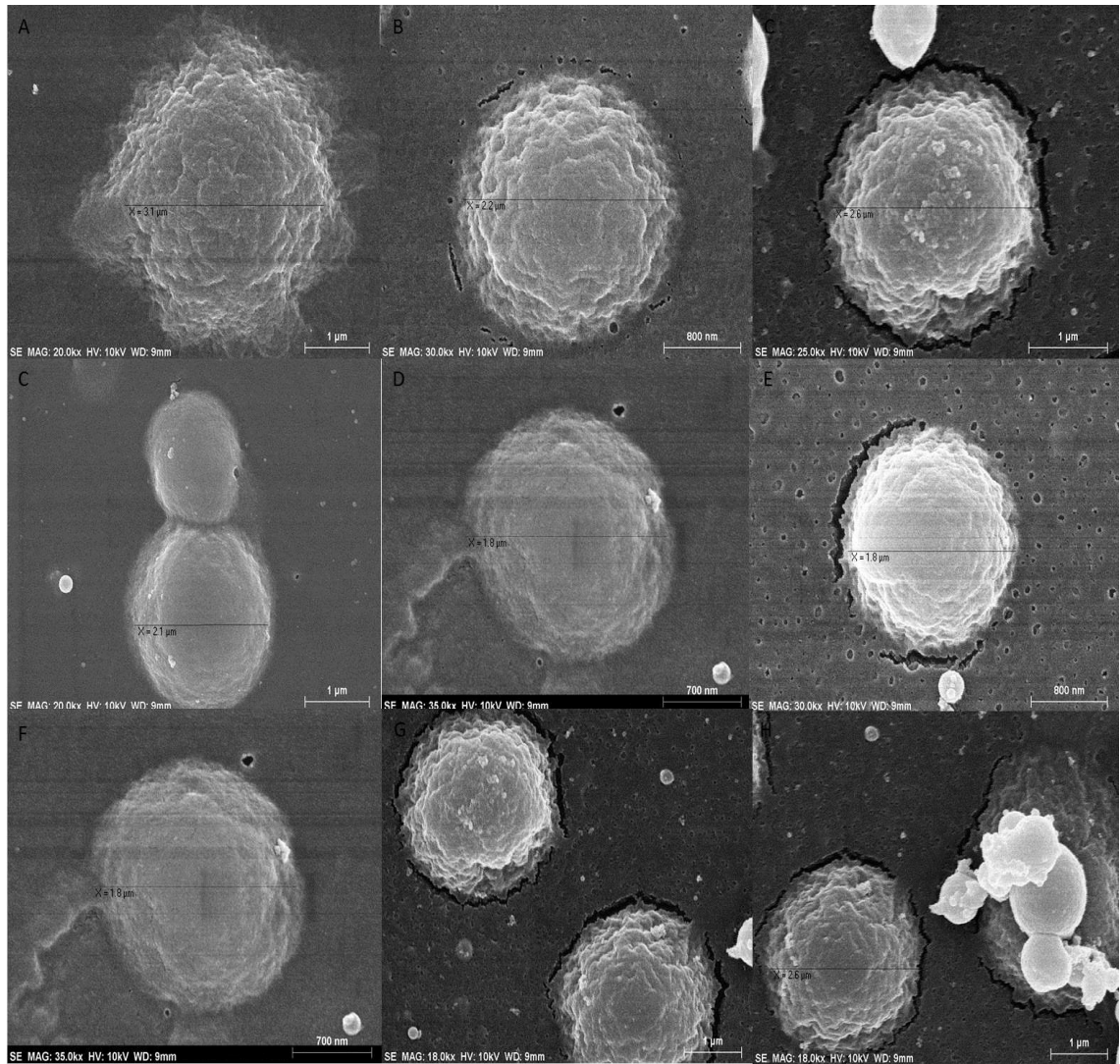

Figure 3.6: The electron microscopy images of spore cultivated in different carbohydrates after 24 hours. Only a mass of highly filamentous hair clump was observed across all treatments without any distinguishing features. A) Glucose, B) galactose, C) lactose, D) maltose, E) mannose, F) ribose, G) xylose and F) fructose.

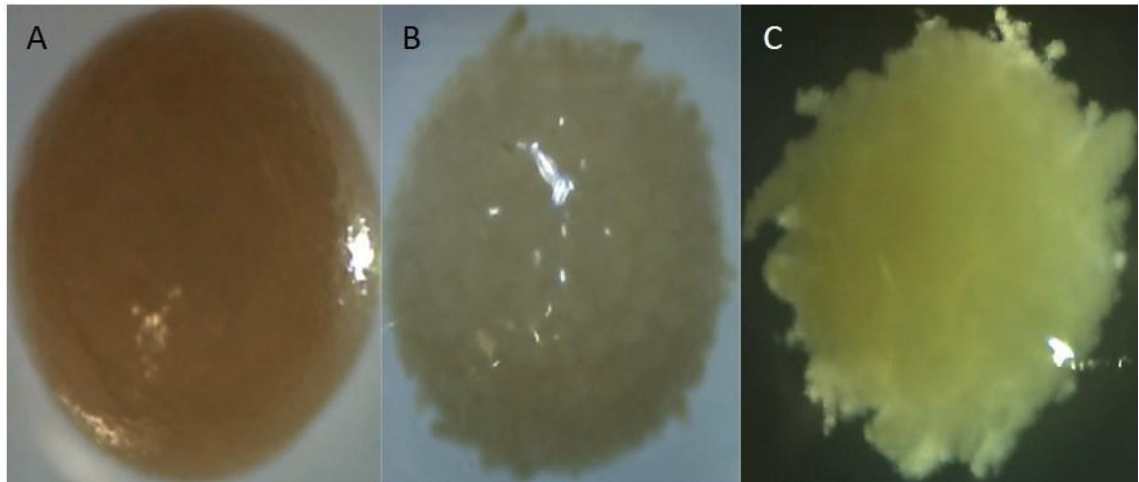

Figure 3.7: **Three major pellet morphologies observed during fermentation of *A. terreus* at day 6.** In A) – hairless (e.g. D-glucose-treated), B) short-haired (e.g. D-fructose-treated) and C) long-haired (e.g. D-arabinose-treated). Hairless pellets were more dense (or heavier) with a lower tendency to clump. Short-haired pellets have a loose feature with a higher tendency to clump, and exhibit patchy hair growth. Long-haired pellets generally have thick filamentous hair; and hollow, porous pellet.

Table 3.4 and Figure 3.8 show the yield coefficient ( $Y_{LOV/S}$ ) of carbohydrates, final biomass ( $X_{FINAL}$ ) of pellet, final diameter ( $\emptyset_{FINAL}$ ) of pellet, final pH and lovastatin production of *A. terreus*. We observed that the production of lovastatin is mainly mixed-growth associated with all the substrate tested, as lovastatin was detected in the early and late phase of biomass production. This mixed-growth pattern was also observed by Bizukoje et al., in the presence of  $\alpha$ -lactose [53]. Low yield coefficients within monosaccharides group were detected in D-galactose ( $Y_{LOV/S} = 1.02$ ), D-arabinose ( $Y_{LOV/S} = 0.66$ ) and D-glucose ( $Y_{LOV/S} = 0.96$ ); while the highest was observed in D-xylose ( $Y_{LOV/S} = 3.49$ ) and D-fructose ( $Y_{LOV/S} = 3.11$ ). Disaccharides, in general, gave a satisfactory production of lovastatin ( $Y_{LOV/S} = 2.01 - 2.94$ ), with sucrose giving the highest yield coefficient ( $Y_{LOV/S} = 2.94$ ).

Slowly-metabolised carbon, particularly  $\alpha$ -lactose ( $Y_{LOV/X} = 4.47$ ) and glycerol ( $Y_{LOV/X} = 9.69$ ), have been described as the optimal carbon source for lovastatin production [35,49]. However, our findings show that there are other carbohydrate substrates with higher efficiency for lovastatin production by *A. terreus* such as D-xylose ( $Y_{LOV/X} = 9.69$ ) and D-fructose ( $Y_{LOV/X} = 8.68$ ). Unlike some organisms [78,79], we observed that the group or structure of sugars (mono- and disaccharides, or pentoses and hexoses, or pyranose or furanose) have no effects on the production of biomass and lovastatin. The details of the parameters given in Table 3.4 and Figure 3.8 would be further discussed in the subsequent paragraphs.

<b>Carbohydrates</b>	<b><math>Y_{LOV/s}</math></b> <b>(mg/g/L)</b>	<b><math>Y_{LOV/X}</math></b> <b>(mg/g)</b>	<b><math>X_{FINAL}</math></b> <b>(g/L)</b>	<b><math>\emptyset_{FINAL}</math></b> <b>(mm)</b>	<b>Final pH</b>
<b>Monosaccharides</b>					
D-arabinose	0.66	1.19	7.28	1.56	7.06
D-galactose	1.02	1.68	8.64	2.32	7.19
D-glucose	0.96	3.30	8.02	2.51	7.16
D-mannose	1.55	5.20	7.28	1.82	6.25
D-ribose	2.42	6.56	8.74	2.52	7.46
D-fructose	3.11	8.68	8.78	2.50	7.01
D-xylose	3.49	9.69	9.24	2.29	6.89
<b>Disaccharides</b>					
D-sucrose	2.94	7.15	9.14	2.31	6.43
D-maltose	2.08	6.06	8.08	2.45	6.91
$\alpha$ -lactose	2.01	4.47	9.44	2.67	6.87
<b>Control</b>					
Glycerol	1.74	3.46	10.44	2.61	6.88

Table 3.4: **The yield coefficients, final biomass ( $X_{FINAL}$ ) and final diameter ( $\emptyset_{FINAL}$ ) of *A. terreus* in the basic media for the period of 6 days.**

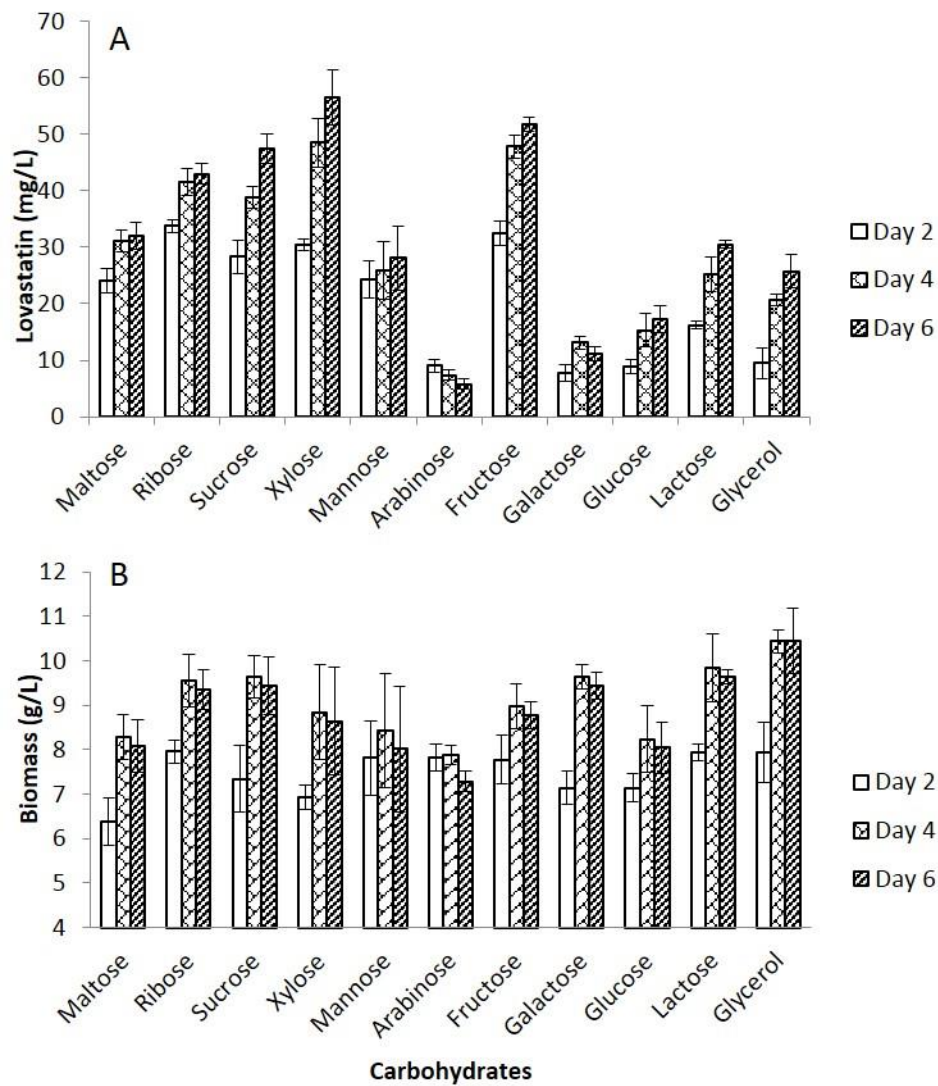

Figure 3.8: **Lovastatin and biomass production under different carbohydrate treatment over the span of 6 days using 4 g/L yeast extract as a nitrogen source.** The production of lovastatin can be grouped into low, medium and high. Biomass productions were generally unaffected across different substrates. Error bars represent 95% confidence interval.



Based on the lovastatin production, these carbohydrates can be characterised into three groups: low (5 – 11 mg/L), medium (17 – 32 mg/L) and high (43 – 57 mg/L) lovastatin production. Low lovastatin production in this experiment is defined by being significantly lower than control (glycerol), medium lovastatin production is similar to the control, and high lovastatin production is defined by being significantly higher than control. The statistical analysis used was described in Section 2.8: Statistical Analysis.

The carbohydrates with high lovastatin production (>40 mg/L), namely D-xylose, D-fructose, D-ribose, and D-sucrose exhibited similar features throughout the investigation. All of these substrates increased lovastatin production significantly (>37%) during stationary phase (day 4) compared to growth period (day 2). In addition, there are also other common features such as having a short-haired pellet morphology; a moderately high final biomass ( $X_{\text{final}}$ ) (8.74-9.24 g/L) and final diameter ( $\emptyset_{\text{FINAL}}$ ) (2.31 – 2.52 mm), and pH approaching 7 (refer to Table 3.4). Previous research has shown that short-haired pellets [34] and moderate  $\emptyset_{\text{FINAL}}$  around 2-3 mm [32–34] have been associated with optimal lovastatin production, and were thought to be due to the balance between growth and oxygen transfer. In contrast, smaller pellets are lacking in both filament zone (lovastatin producing) and core region (oxygen containing). Similarly, large pellets would reduce the nutrients and oxygen penetration into the middle of the pellet, which would cause necrosis and hollow pellet [44]. Carbohydrates with medium lovastatin production (17 – 32 mg/L), namely D-glucose,  $\alpha$ -lactose, D-maltose, D-mannose and glycerol, exhibited unique pellet morphologies when compared to those with high lovastatin production. Of note, we noticed that the pellets exhibited hairless morphology in the presence of D-glucose, D-maltose, and  $\alpha$ -lactose (Figure 3.7A), all of which corresponded with lower lovastatin production. Glycerol (control experiment), on the other hand, had almost identical features to the high yield-

producing carbohydrates including morphology, pH and  $\emptyset_{\text{FINAL}}$ . Only its  $X_{\text{FINAL}}$  (10.44) is very high which indicates high growth.. While biomass production is also important for the viability of fungus, excessive biomass increase may suggest that the metabolic route was shifted towards fatty acids biosynthetic pathway. This may adversely affect the production of lovastatin due to competition for carbon that serves as precursors (refer to Figure 3.10 for metabolite production pathway). Due the complexity of the reaction (refer Figure 3.11), there is a possibility that the available carbon source will be redirected to other pathways rather than the metabolite production, In contrast, low  $X_{\text{FINAL}}$ , as observed under D-maltose and D-mannose treatment, may also reduce lovastatin production due to lack of necessary growth for metabolite production.

In the low production group (D-galactose and D-arabinose), D-galactose treatment exhibited an unfavourable hairless morphology similar to the medium production group. Also, the biomass increase (Table 3.4) indicated that D-galactose was probably redirected to growth, rather than the metabolite production, similar to glycerol. Incomplete D-galactose uptake was also observed (Figure 3.9), most likely due to the lack of galactose utilisation pathway in *A. terreus* [80]. In contrast, we observed pellets with long hair feature, displaying gelatinous-like morphology in D-arabinose (Figure 3.7c), which corresponded with lowest  $X_{\text{FINAL}}$  and  $\emptyset_{\text{FINAL}}$ . This is consistent with previous reports showing that long hair, highly filamentous morphology is unfavourable as this may reduce the nutrient transfer ability [81]. Furthermore, the formation of highly filamentous pellet reduces the formation of pellet or core body, which is essential for lovastatin formation. This is shown in Figure 3.7C, and also based on its  $X_{\text{FINAL}}$  (which was the lowest, as pellet body contributed to most of its weight). Other possible explanation on the effect of different carbohydrates on lovastatin production is shown in Table 3.5.

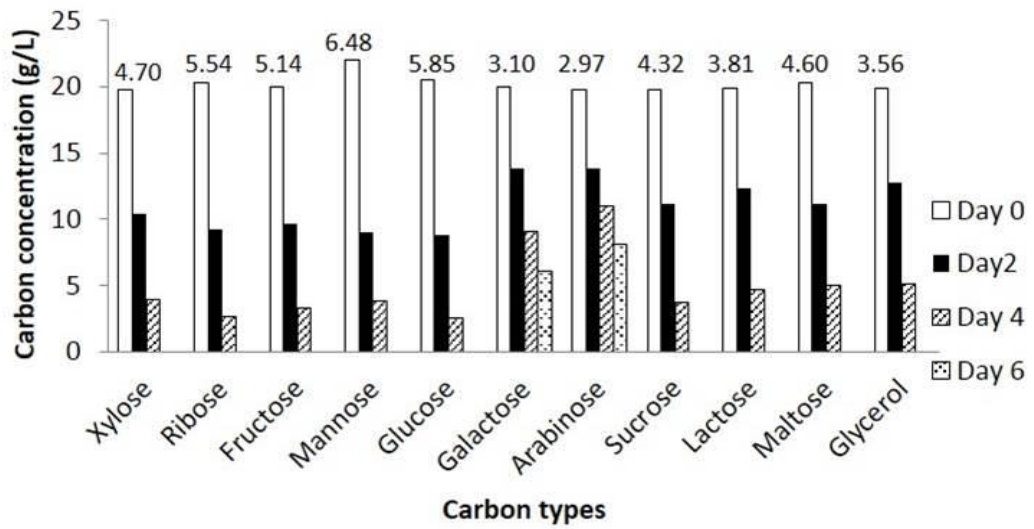

Figure 3.9: **The consumption and consumption rate of carbon sources by *A. terreus*.**

The numbers at the top of the bar graph represent the consumption rate,  $r$ . The consumption rate was taken at day 2, assuming the fungus was in its most active state (trophophase).

Carbons	Lovastatin	Possible explanation (s)
D-arabinose	5 – 11 mg/L (Low)	<ul style="list-style-type: none"> <li>- Uncommon in nature. Low uptake rate (Figure 3.9). Not preferred by fungus [82].</li> <li>- Established pathway of arabinose metabolism in the fungus is the oxidoreductase pathway, which involves L-arabinose and not D-arabinose [83].</li> </ul>
D-galactose		<ul style="list-style-type: none"> <li>- Uncommon in fungus' native habitat. Low uptake rate.</li> <li>- Lack both <i>galR</i> and <i>galX</i> regulators that control the utilisation of D-galactose in <i>A. terreus</i> [80].</li> <li>- The breakdown of galactose into glucose, and subsequently through pentose phosphate pathway (PPP) may cause catabolite repression (Figure 3.11).</li> </ul>
D-glucose D-maltose	17 – 32 mg/L	<ul style="list-style-type: none"> <li>- Suppression of lovastatin maybe due to catabolite repression [37] through PPP (Figure 3.11).</li> </ul>
Glycerol $\alpha$ -lactose	(medium)	<ul style="list-style-type: none"> <li>- Slowly-metabolised (Figure 3.9) and the rate was increased consistently up to day 6. Production was lower than expected [49,50], probably due to the difference in culture condition (Table 3.6).</li> <li>- The breakdown of lactose into glucose, and subsequently through PPP may cause catabolite repression (Figure 3.11).</li> </ul>
D-mannose		<ul style="list-style-type: none"> <li>- Lovastatin production maximises and plateau at day 2, which may limit its potential as a carbon source.</li> </ul>
D-xylose D-fructose D-sucrose D-ribose	>40 mg/L (High)	<ul style="list-style-type: none"> <li>- Abundantly found in nature, which increase the likelihood to be metabolised efficiently by <i>A. terreus</i>.</li> <li>- For example, <i>mstA</i> transporter is used in fungus to transport certain carbons such as D-xylose into the cell [49,84].</li> </ul>

**Table 3.5: The possible explanations on the effect of different carbohydrates as carbon sources on the production of lovastatin by *A. terreus*.**

Carbon source	Nitrogen source (lovastatin yield on biomass (mg/g))			Minerals
	Yeast extract	CSL	Soybean meal	
Lactose	29.20	22.66	30.42	MgSO <sub>4</sub> ·7H <sub>2</sub> O
Fructose	25.47	20.08	12.66	NaCl,
Glycerol	21.80	18.03	11.46	Na <sub>2</sub> B <sub>4</sub> O <sub>7</sub> ,
				MnCl <sub>2</sub> ,
				Na <sub>2</sub> MoO <sub>4</sub> ,
				CuSO <sub>4</sub>

Table 3.6: **The example of the lovastatin yield (mg/g) obtained using different media composition.** The combination of different carbon and nitrogen sources affected lovastatin yield greatly. The data was extracted from [49]. The effect of starting substrate/carbon has been illustrated in Section 1.2.4, Table 1.1.

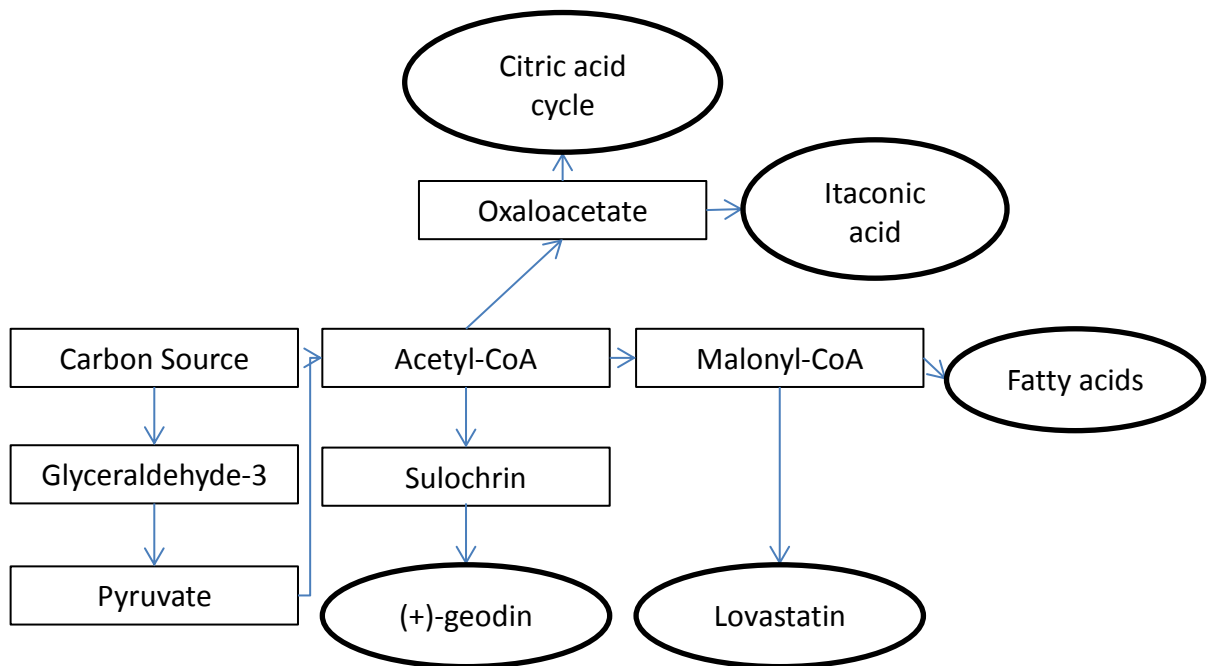

Figure 3.10: **Metabolite production pathway by *A. terreus* ATCC 20542.** Note that all metabolite production requires Acetyl CoA as its main precursor. Acetyl-Coa and Malonyl-CoA act as precursors to all reactions. The channelling of more precursors towards one pathway may potentially cause a deprivation of precursors for other pathways.

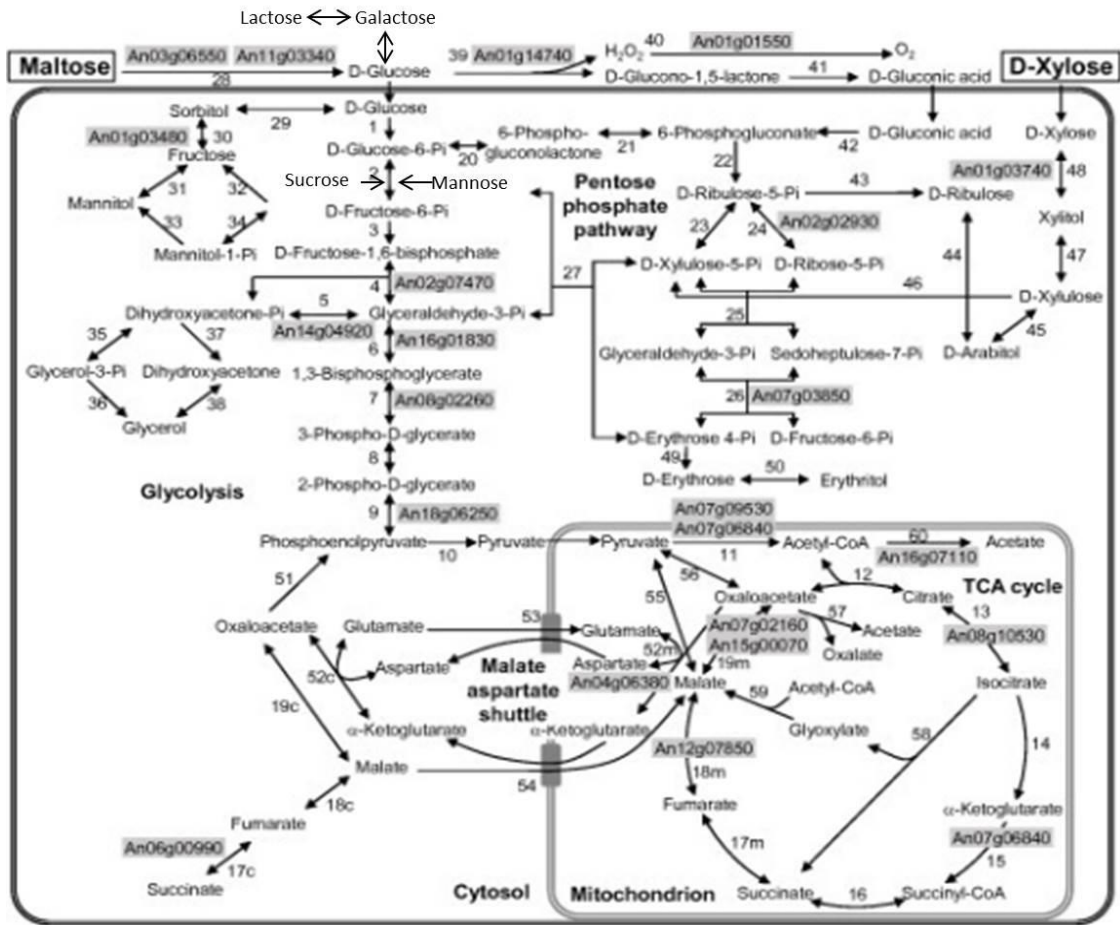

Figure 3.11: Possible catabolism pathways of several different carbon sources in *A. terreus*. The presence of complex and branching pathways for each carbon catabolism may remove available carbon source for metabolite production Adapted from [85].

To further confirm the findings, we performed mRNA analysis on each of the fungus treated with the different carbohydrates. As stated previously, we chose *lovB* as our gene of interest as *lovB* is one of the main genes that are responsible for lovastatin production, based on the recommendation by Sorrentino F. et al. [86]. Our gene analysis showed almost an even expression mRNA transcript of *lovB*, and in some cases, the opposite of what has been observed with lovastatin production (Figure 3.12). For example, we observed that maltose produced higher lovastatin than glucose, but its *lovB* mRNA levels suggest an inverse role between those two.

Based on molecular pathway, one could see that the production of lovastatin is not only governed by a single gene, but is controlled by a number of different genes (refer to Chapter 1: subsection 1.0.2). Different carbohydrates may induce a different set of genes, which causes gene expression studies to be very difficult. Unless a complete mapping of gene expression is done, it would not be possible to study the effect of a single gene factor in the production of lovastatin. Furthermore, the study only measures the production of mRNA, which may not necessarily translate into proteins. Therefore, additional work looking at the protein expression of genes of interest may give more insight into the production of metabolites of interest.



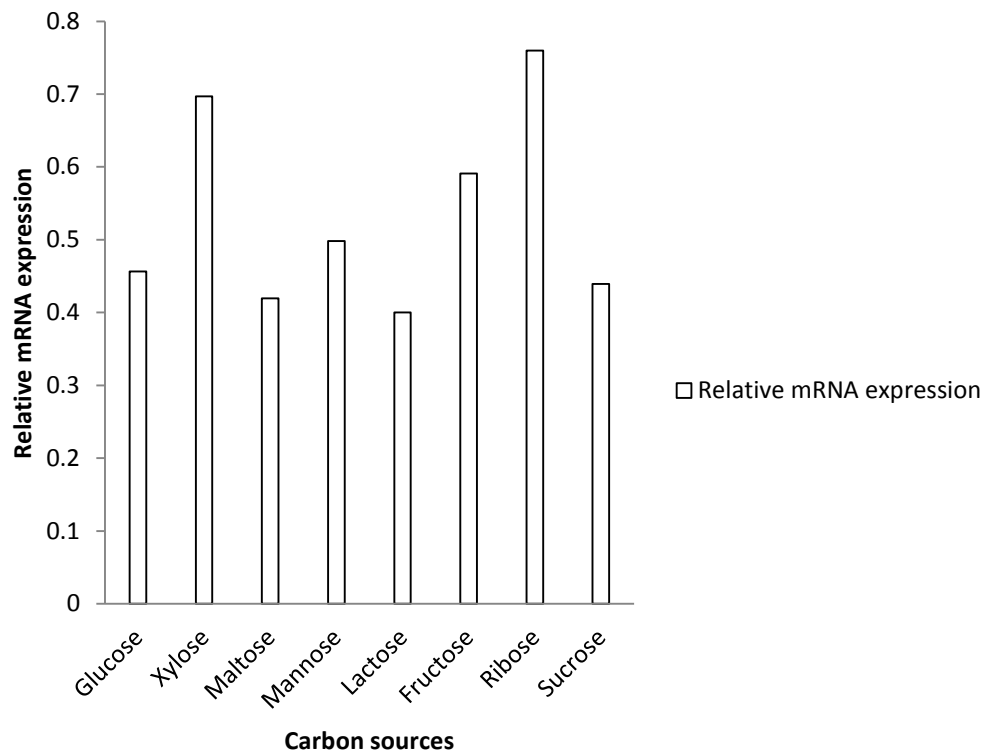

Figure 3.12: **The relative lovB mRNA expression under the influence of eight carbohydrates.** The expression does not correspond to lovastatin production due to the presence of multiple genes (e.g. lovA, lovC, lovD and lovF) that govern lovastatin production, and possible differences in the translated protein (from mRNA)

### 3.4.3 (+)-geodin and sulochrin production

Amongst the many secondary metabolites produced by *A. terreus*, (+)-geodin and sulochrin are the two major metabolites that originate from the same pool of precursors as lovastatin but are produced via different pathway. Therefore, it is likely that the production of these metabolites may compete with each other for the precursors. This has been suggested previously for sulochrin [64]. The possibility that these metabolites may have a stimulatory effect should not be excluded as another metabolite, butyrolactone I, has been shown to stimulate lovastatin production. Therefore, we evaluated the production of these co-metabolites in relation to lovastatin production.

Figure 3.13 shows the amount of (+)-geodin and sulochrin in culture media over 6 days of fermentation. We observed that (+)-geodin and sulochrin production was lower than lovastatin, and independent of the carbohydrate sources used. A similar observation has been reported for (+)-geodin previously [60]. The low yield obtained in this study may result from the limited carbon availability towards the end of the stationary stage of fungus fermentation. This has been shown previously where (+)-geodin production was dependent on the residual carbon at the end of fermentation, by using lactose as the substrate in batch fermentation [60].

Our findings also suggest that (+)-geodin may be prone to degradation, or perhaps re-used by the fungus in some way, as its production gradually declined over time with lactose as a carbon source. This explanation would be further explored in the subsequent chapters.

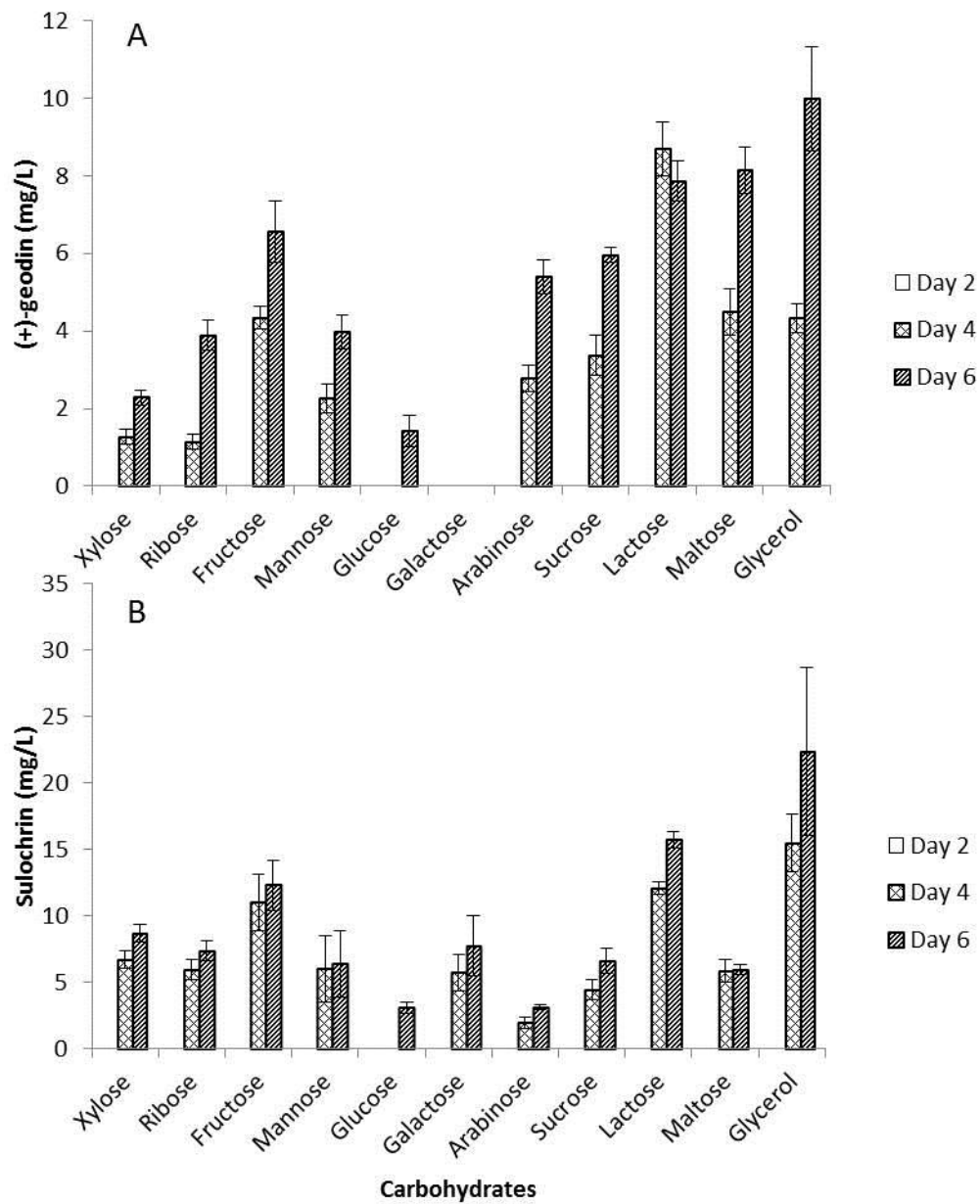

Figure 3.13: **Sulochrin and (+)-geodin production under different carbohydrates over the span of 6 days in a basic medium with 4 g/L of yeast extract as a nitrogen source.** Data are means of triplicates and error bars represent 95% confidence interval.

Although the production of (+)-geodin is very low, some carbohydrates showed a noticeable increase. Some carbon sources (D-sucrose, D-arabinose,  $\alpha$ -lactose and glycerol) showed low, but a sustained (+)-geodin production up to 6 days. Others showed only transient to no (+)-geodin production. For instance, no production of (+)-geodin was observed in D-glucose on day 2 and 4, suggesting that the catabolite repression mechanism may be more pronounced in (+)-geodin synthesis rather than lovastatin in this case. (+)-geodin was also undetectable in a D-galactose-treated culture which corresponded to low lovastatin production, suggesting that this carbohydrate source may be unsuitable for the biosynthesis of these metabolites in *A. terreus*. Surprisingly, D-arabinose seemed to have differential effects on metabolites such that lovastatin production was repressed but (+)-geodin production was enhanced (2.78 mg/L, day 6). (+)-geodin was detected in a high amount (Day 6) in D-sucrose (4.42 mg/L),  $\alpha$ -lactose (3.79 mg/L) and glycerol (3.73 mg/L), probably due to their slow-metabolised feature (refer to Table 3.6 for carbohydrate consumption). This corresponded to a greater increase in (+)-geodin production compared to lovastatin, suggesting that slowly-metabolised carbon sources are possibly more suitable for (+)-geodin production as this would provide higher residual carbon towards the end of fermentation, which may stimulate (+)-geodin production.

Sulochrin is another secondary metabolite (octaketide compound) that serves as a precursor or intermediate for (+)-geodin and asterol synthesis. Compared to (+)-geodin, the production of sulochrin was more sustained throughout the fermentation. Furthermore, sulochrin's production was greater compared to (+)-geodin under all carbohydrate treatments, except for D-arabinose. So far, the reason for this phenomenon is still unexplainable without further experiment.

We next assessed the relationship between sulochrin and (+)-geodin production. While the production of (+)-geodin was undetected in D-xylose, the production of sulochrin (10.99 mg/L, day 6) was high. In contrast, D-arabinose produced low sulochrin (1.57 mg/L, day 6) but higher (+)-geodin production (2.78 mg/L). Sulochrin in glycerol (22.35 mg/L, day 6),  $\alpha$ -lactose (10.39 mg/L, day 6) and D-fructose (13.48 mg/L, day 6) followed a similar trend to what has been previously observed in (+)-geodin's production, while other carbohydrates led to similar (or basal) amounts of sulochrin at the end of fermentation. These results indicate that there is no clear trend across all carbohydrates to suggest that sulochrin and (+)-geodin production is influenced by the same factors. These results reaffirm the complexity of the evolved metabolism of *A. terreus*, and suggest that there are different carbon growth conditions to enhance metabolite production of lovastatin, (+)-geodin and sulochrin.

### **3.5 Conclusion**

We found that the production (+)-geodin and sulochrin is more responsive to the different type of nitrogen sources, while lovastatin is more responsive to the type of carbon sources. There was no apparent connection between the production of lovastatin, (+)-geodin and sulochrin in this study when different carbon sources were used. The only common observation is the production of lovastatin and sulochrin is more constant, unlike (+)-geodin which is more erratic. Unlike morphology, the biomass and lovastatin production are not likely to be related as initially thought, as low biomass fungal pellet still produced an excellent amount of lovastatin, even after they reached the lag phase (indicated by the constant biomass weight).

## Chapter 4 - Cultivation of *A. terreus* in crude glycerol

### 4.0 Introduction

Based on the previous chapter, glycerol was found to be a good substrate for lovastatin, and an even better substrate for (+)-geodin and sulochrin production. Thus, this finding was used as a basis to find a suitable bio-waste for the cultivation of *A. terreus*. The present study explores the potential use of crude glycerol (CG) instead of pure glycerol (PG), as a feedstock for the production of metabolites by *A. terreus* ATCC 20542. Little is known about the regulation and the physiology of metabolite biosynthesis of lovastatin using CG.

CG was previously considered a valuable by-product derived from biodiesel industry. However, the rapid growth of the biodiesel industry resulted in an overproduction of CG, leading to its significant devaluation [87]. For example, the price of refined glycerol plunged more than 50%, from USD\$100 in 2004 to around USD\$40 in 2007 [88]. CG has become a burden, especially for small biodiesel producers, as improper disposal is harmful to the environment, and purification processes are not cost-effective [89].

The bioconversion of CG is particularly challenging as biodiesel-derived CG contains a significant amount of impurities. CG contents vary widely with the biodiesel manufacturer, ranging from 38% to 96% glycerol; with the remaining normally comprised of water, MeOH, free fatty acids and salts [90]. MeOH and fatty acids are formed during the trans-esterification process; while salt originates from the catalyst used in the biodiesel production process. High contents of impurities in CG may inhibit the production of metabolites in most microorganisms [68,91,92]. However, some

microorganisms that prefer glycerol as a substrate may adapt themselves to use CG. For example, microalgae *Schizothyrium limacinum* [93], yeast *Yarrowia lipolytica* [94] and bacteria *Clostridium butyricum* [73] can utilise CG for the production of lipids, citric acid and 1,3-propanediol respectively. *A. terreus* is of particular interest, mainly due to its fungus characteristics which is known for their ability to withstand different contaminants present in CG.

This study reports the potential of *A. terreus* to assimilate crude glycerol and produce desired secondary metabolites when CG and pure glycerol (PG) are used as the sole carbon source. The first series of experiments involved the cultivation of *A. terreus* with varying concentration of crude glycerol to assess the production of lovastatin and (+)-geodin. Thereafter, the optimum concentration of CG and PG in shake flask was cultivated in a bioreactor and used in a further study to assess the effect of impurities on the secondary metabolite production, with a particular focus on MeOH, salt and fatty acids. Finally, the efficiency of pre-treated CG was evaluated by assessing the growth and production of metabolites by *A. terreus*. The summary of the experimental method for impurities in this chapter is shown in Table 4.1.



<b>Impurities</b>	<b>Amount present in CG (g/L)</b>	<b>Concentration used in media (g/L)</b>
		0.25
MeOH	1	0.5
		1
		1
NaCl	2	2
		4
		0.3
Fatty acids	Unknown, may reach 20	1.5
		3

Table 4.1: **Chemical composition and experimental design of impurities used in this study.** To avoid variation in the impurities present in the sample, the same batch of CG was used for every experiment. All experiments used basal salt media as described in methodology, 30 g/L PG and 4 g/L of yeast extract. Control experiments were untreated media. All experiments were conducted in triplicates.

#### **4.1 Growth, glycerol consumption and metabolite production**

The ratios of glycerol to yeast extract were fixed at 2.5, 7.5 and 12.5 in all experiments by adjusting the amount of CG added to the media (CG contains only 45% of glycerol). The biomass profile at day 6 is shown in Figure 4.1. In general, the biomass increased with increasing PG and CG concentration. In all cases, the concentration of biomass was only slightly higher in the presence of PG compare with CG. This shows that the impurities present in CG have minimal effects on *A. terreus* growth, consistent with previous studies which reported the ability of different strains of *Aspergillus* species survive on industrial wastes (excluding CG) [95,96].

Figure 4.2 shows the trend of the CG and PG consumption rate by *A. terreus* as a function of cultivation time (days) at different initial substrate concentrations. Rapid glycerol consumption was observed in the early stage, followed by reduced uptake rate over time in the presence of both substrates, which obey the basic principle of microorganism growth curve. This also a possibly indicates a shift in *A. terreus* growth from an exponential phase to a lag phase. There was less consumption of CG compared to that of PG, indicating that the quality of glycerol is essential for substrate uptake efficiency. The difference in the glycerol consumption was more noticeable at 50 g/L where glycerol content in PG was exhausted by day 6 whereas residual glycerol was still detectable in CG (~11 g/L). This indicates that the ability of the fungus to utilise CG might be impaired as a result of increased toxicity due to inhibitors present in CG.

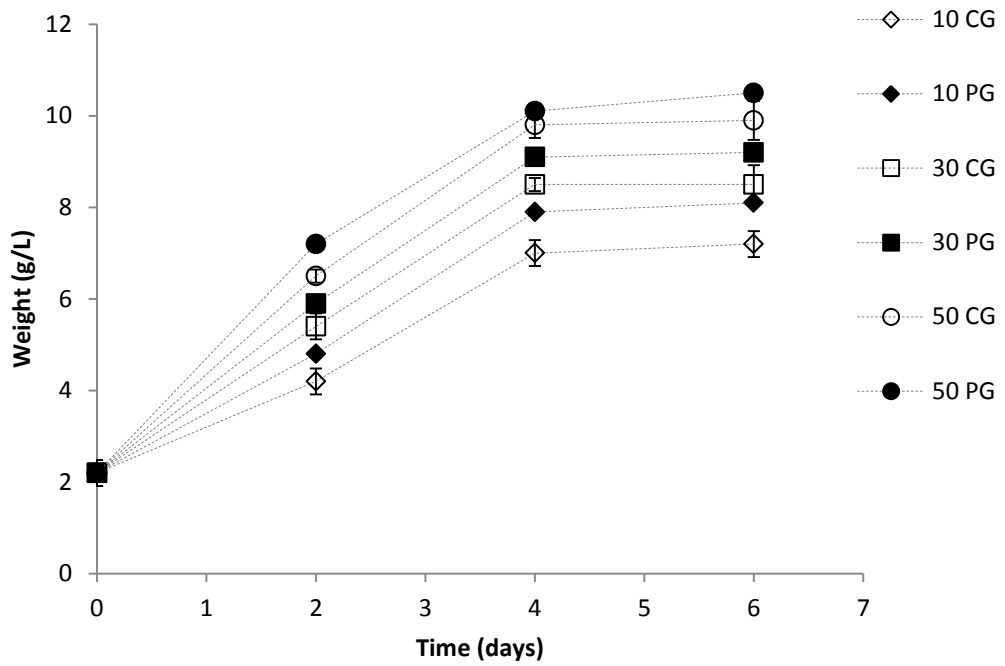

Figure 4.1: **The biomass growth curves of *A. terreus* in the presence of different concentrations of CG and PG.** Concentrations of the substrates have a bigger influence on biomass growth compared to the type of substrates. Symbols show experimental values while dashed lines connecting symbols are used as a visual guide only. Error bars show 95% confidence.

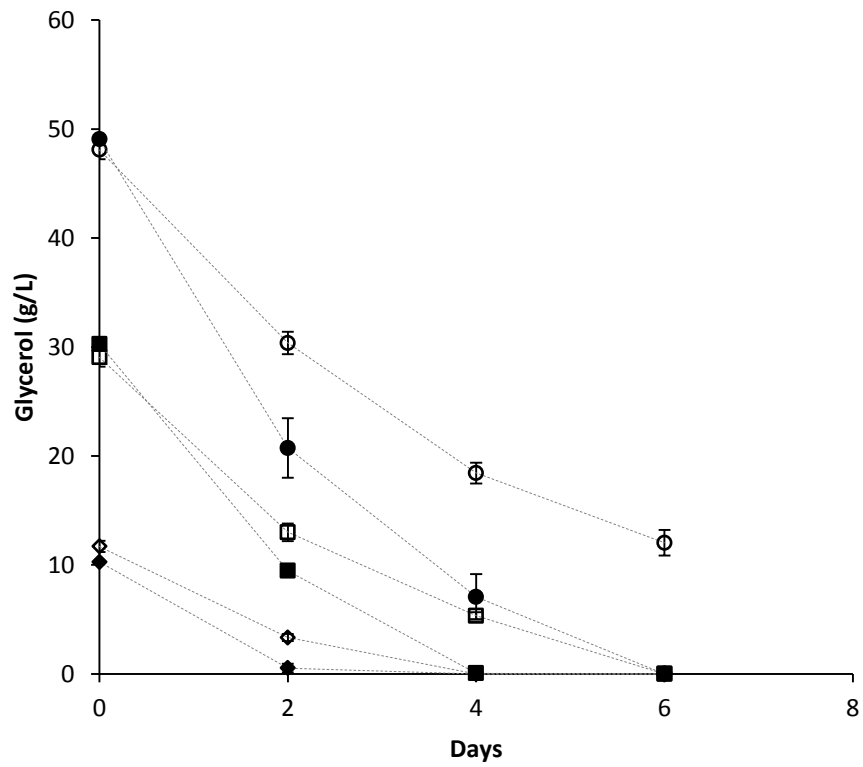

Figure 4.2: **Effect of different concentrations of PG and CG on glycerol consumption by *A. terreus* in 50 mL shake flask experiment.** CG reduced glycerol consumption at all concentration with 50 g/L CG showed residual glycerol after day 6 of cultivation. Closed symbols represent PG while open symbols represent CG.

It has been established that (+)-geodin is one of the primary co-metabolite of lovastatin biosynthesis [22,60]. The production of (+)-geodin is associated with the production of sulochrin due to the fact that sulochrin is a precursor for its production [58,59]. Hence, it is interesting to study the possible link between their production with that of lovastatin and how the production may react to the same factors that affect lovastatin production.

The concentration of metabolites produced, namely lovastatin, (+)-geodin and sulochrin, for 6 days cultivation period is shown in Figure 4.3. The use of PG resulted in significantly higher lovastatin production than CG at all concentrations of glycerol. The production of lovastatin appeared to slow down as glycerol is exhausted, except at 50 g/L CG, which showed an initial lag phase in lovastatin production at day 2 and 4. The production of lovastatin in PG was the highest at 30 g/L, ( $C_{LOV30} = 19.5$  g/L;  $C_{LOV50} = 18.9$  g/L), which is within the range of a previous report [53]. However, both product and biomass yield coefficient was optimal at 10 g/L of PG ( $Y_{LOV/S} = 1.35$  mg/g/L,  $Y_{LOV/X} = 1.51$  mg/g), compared to 30 g/L ( $Y_{LOV/S} = 0.48$  mg/g/L,  $Y_{LOV/X} = 1.49$  mg/g) and 50 g/L of PG ( $Y_{LOV/S} = 0.28$  mg/g/L,  $Y_{LOV/X} = 0.28$  mg/g). Similarly, 30 g/L CG ( $C_{LOV30} = 10.1$  g/L) was also the highest for lovastatin production, while 50 g/L CG ( $C_{LOV50} = 3.4$  g/L) produced a significantly lower lovastatin production. While the pattern of  $Y_{LOV/S}$  in CG was the same with PG, the  $Y_{LOV/X}$  was the highest in 30 g/L CG (1.1 mg/g), compared to 10 g/L CG ( $Y_{LOV/X} = 0.97$  mg/g). This observation indicates that the production of lovastatin increased at a higher rate (with respect to biomass) in the presence of 10 to 30 g/L of CG, compared to PG.

The use of CG may negatively influence lovastatin production due to the presence of contaminants in CG. Some secondary metabolites are enhanced in the presence of these

foreign substances, such as (+)-geodin and sulochrin, as a part of their natural response to the stress condition. This indicates that lovastatin may not play an important role in this part of the stress response, or simply that certain substance in CG may be inhibitory to its production. This hypothesis is explored further in Section 4.2: Effect of impurities.

In control experiments, lovastatin production has always exceeded (+)-geodin and sulochrin, as observed in the presence of PG (Figure 4.3). We also noticed that (+)-geodin and sulochrin were produced later than lovastatin, and maximised towards the end of the cultivation process (Figure 4.3). This indicates that the production of these metabolites may be associated with nitrogen deprivation phase [36,60], which often occurs after a few days of cultivation. This observation is supported by the evidence that (+)-geodin production is inhibited by the presence of organic nitrogen in the media [36,60]. In PG, the concentration of (+)-geodin increased in a dose-dependent manner that indicates its production is highly dependent on the amount of initial carbon content in the growth media. This is supported by a study conducted by Bizukojc et al. (2007), which reported that the initial carbon content has a more pronounced influence on (+)-geodin production compared to lovastatin [60]. The presence of higher carbon source concentration, especially towards the end of cultivation, is important to maintain and sustained (+)-geodin's production [60]. However, compared to PG, the production of (+)-geodin and sulochrin were significantly higher in the presence of equal concentrations of CG, except at 50 g/L. This observation suggests that (+)-geodin and sulochrin is more responsive to an adequate amount of CG, due to the presence of inhibitory compounds in CG (further explored in Section 4.2: Effect of impurities). However, 50 g/L of CG showed significantly lower (+)-geodin and sulochrin production, presumably due to the presence of excessive amount of impurities that may negatively affect their metabolite production pathway.

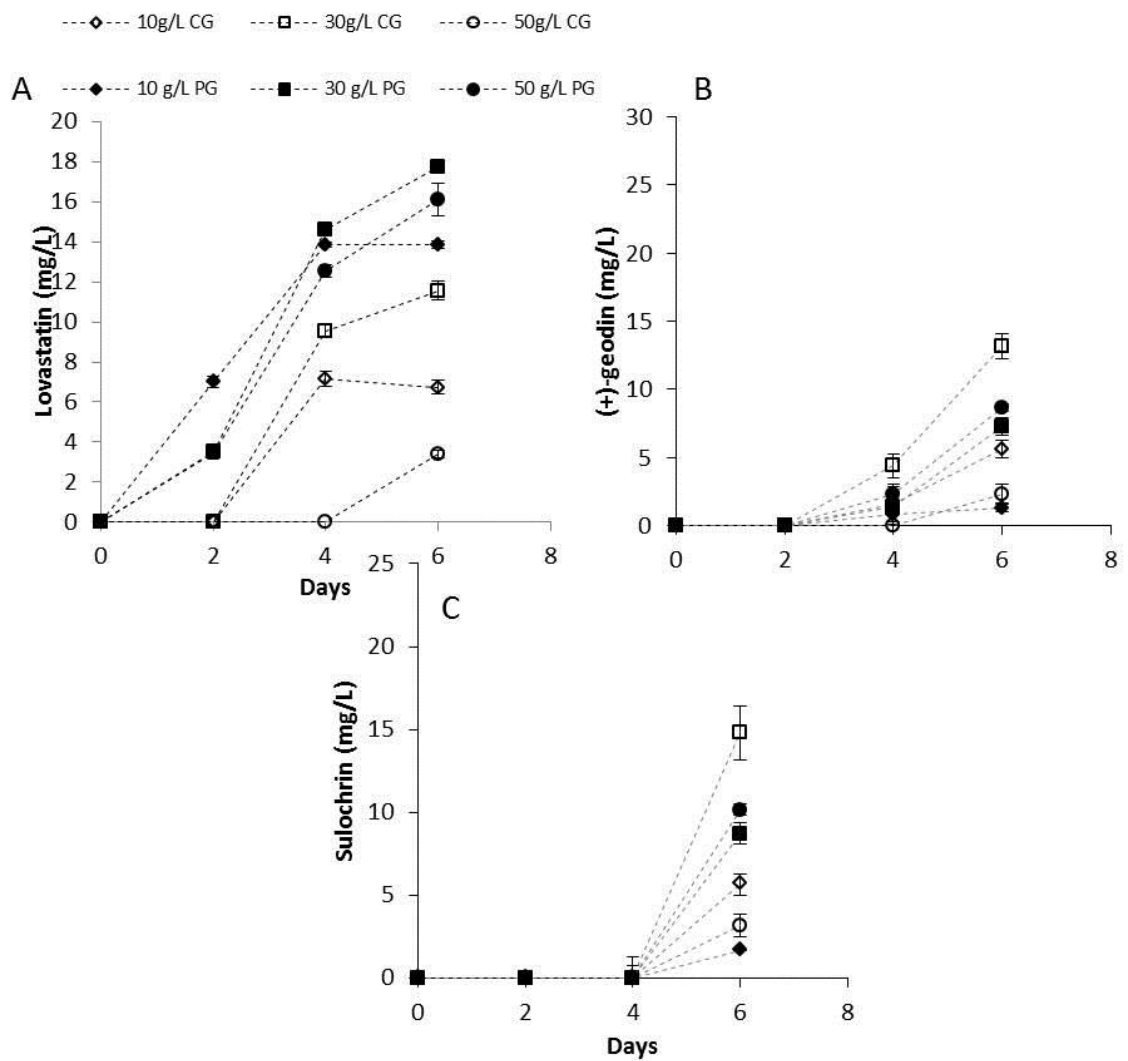

Figure 4.3. Time course of (A) lovastatin, (B) (+)-geodin and (C) sulochrin production by *A. terreus* in a shake flask experiment using different concentrations of PG and CG. In (A), PG produced significantly higher lovastatin than CG at all time points. In (B) and (C), both (+)-geodin and sulochrin production were significantly higher at 10 and 30 g/L of CG at day 6. A value of  $p < 0.05$  is considered significant.

In terms of morphology, the pellet diameter between these two treatments was roughly the same. The more notable change was observed on the surface of the pellet. The use of PG produced considerably fluffier pellet while CG produced hairless morphology (refer to Chapter 3: Optimisation of basic media condition for further discussion). The presence of hair is probably the most obvious indicator that influences the pattern of metabolite production, as fluffier and looser pellets have been implicated in higher lovastatin production [34]. In terms of (+)-geodin's production, there has been no study yet that examined the relationship between pellet morphology and its production. From this result, the production of (+)-geodin and sulochrin seemed to be independent of this factor as the increase of these metabolites were observed regardless of the presence of hair.



## **4.2 Effect of impurities**

Given that the use of CG as a substrate resulted in different patterns of metabolite production compared to PG, additional studies were conducted to investigate whether these variations or changes in metabolite production were mainly due to the presence of the major impurities in CG, which are MeOH, salt (NaCl) and fatty acids. In this experiment, known concentration of impurities (based on the concentration present in CG) was added on top of 30 g/L of PG to assess its effect on lovastatin, (+)-geodin and sulochrin production by *A. terreus*.

### **4.2.1 Methanol improved lovastatin production but suppress (+)-geodin and sulochrin production**

Figure 4.4 shows the production of lovastatin, (+)-geodin and sulochrin using PG as a carbon source in the presence of different concentrations of methanol (MeOH) over the course of 6 days of cultivation. MeOH addition suppressed the production of (+)-geodin and sulochrin at all concentrations while it appeared to significantly stimulate lovastatin production. Of note, increasing MeOH concentration to 1 g/L reduced lovastatin production at day 4, although it recovered on day 6. This may be related to the reduction of glycerol consumption, as only the addition of 1 g/L MeOH reduced the consumption of glycerol by almost 13% on day 2. It can be also due to the growth suppression, as the pellet diameter was considerably smaller at this concentration compared to when 0.25 g/L and 0.5 g/L of MeOH was used (Table 4.2). Although the inhibition of biomass was also observed, the pattern was not concentration-dependent (Table 4.2), which make it unlikely to be the reason. No difference in term of hair growth was observed between control (PG) and MeOH this time, as both produced fluffy pellets.

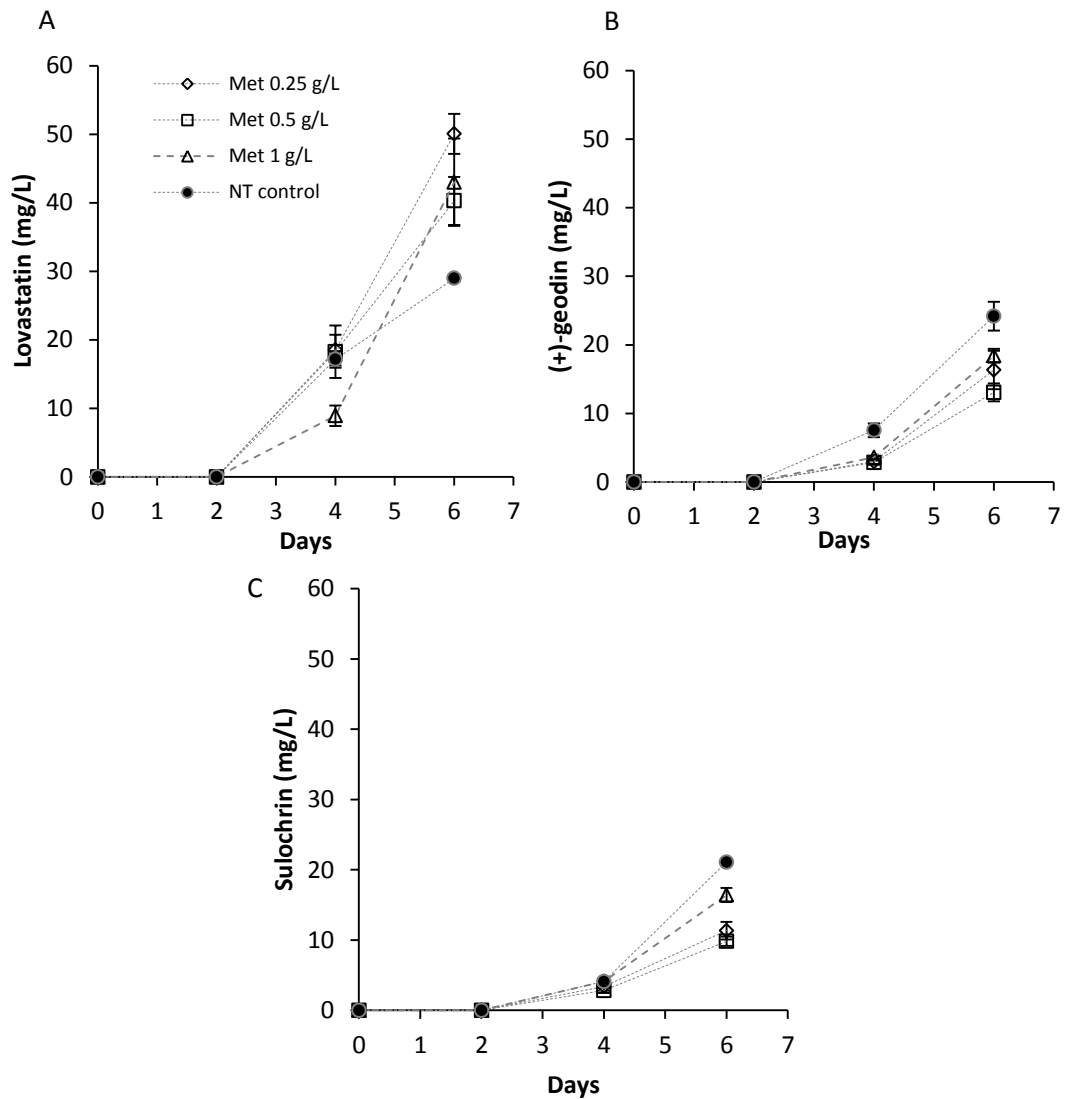

Figure 4.4: **Effect of methanol (MeOH) addition to (A) lovastatin production, (B) (+)-geodin production and (C) sulochrin production by *A. terreus* in shake flask experiment.** In (A), production of lovastatin is significantly higher in MeOH compared to NT control at day 6, while its production at 1 g/L of MeOH was shown to be significantly lower at day 4. In (B) and (C), all the MeOH-treated media produced significantly lower (+)-geodin and sulochrin than NT control at day 6. Significance is when  $p < 0.05$ .

Parameters	MeOH initial concentration (g/L)				
	Day	0 (control)	0.25	0.5	1
Glycerol	Day 0	32.9	32.9	32.9	32.9
Concentration (g/L)	Day 2	9.0	8.3	10.7	12.2
Biomass (g/L)	Day 6	9.4 ± 0.23	7.6 ± 0.52	7.3 ± 0.12	7.5 ± 0.52
Diameter (mm)	Day 6	3.0 ± 0.06	2.4 ± 0.12	2.4 ± 0.06	2.0 ± 0.09

Table 4.2: Growth parameters of fungus in shake flask after six days of cultivation of *A. terreus* in the presence of different initial concentrations of methanol (MeOH).

The stimulatory effect of MeOH on lovastatin production is in agreement with a previous study which shows that MeOH influences the transport of molecules in microbial cells, mainly through its effects on cell membrane integrity by regulating enzymatic and membrane fluidity [97,98]. With the assumption that some of the lovastatin resides intracellularly, the changes in cell membrane integrity induced by MeOH may allow increased transport of lovastatin into the extracellular media. There may be a preferential assimilation of MeOH compared to glycerol, given that MeOH is also considered as a type of carbon source [99–101]. Kinetically, MeOH may be favoured over glycerol during assimilation, as MeOH can be incorporated into 2 products, compared to 1 for glycerol. Further, the presence of MeOH may induce the MeOH metabolizing genes, whilst the lower production of both (+)-geodin and sulochrin may be due to the repression of stress response genes required for the production of (+)-geodin and sulochrin [102].

In terms of a morphological factor, MeOH was implicated to improve the pellet morphology by reducing the size of the pellet [98,103], which was also observed in this study. Smaller pellet size (Table 4.2) was shown to increase the efficiency of oxygen transfer and the total area of the active region inside the fungus that is responsible for its metabolite production [43]. Although the pellet size was reduced, this did not interfere with the ability of the fungus to grow, as indicated by the stable biomass weight (Table 4.2). However, high amount of MeOH may reduce the size of the pellet to the point where the efficiency of lovastatin production is probably compromised.

Currently, it is unknown why there is a different response of lovastatin, (+)-geodin and sulochrin production, and carbon consumption profile under the effect of MeOH and further investigation is needed. Nevertheless, this result indicates that the presence of

MeOH positively influences lovastatin production, which is in contrast to our observation in the presence of CG. Therefore, it is unlikely that the presence of MeOH in CG contributed to reduced lovastatin production unless there is a different effect when the contaminants are present together in the media.

#### **4.2.2 Sodium chloride induced the production of lovastatin, (+)-geodin and sulochrin**

The effect of sodium chloride (NaCl) on the production of three metabolites of interest in *A. terreus* is shown in Figure 4.5. This salt constitutes about 0.2% of the total CG (w/v), although it is estimated that the total content of combined salts is much higher (part of MONG value, refer to Materials and Methods). It is evident that the presence of NaCl at low concentration (1 g/L) significantly enhanced lovastatin production (31% increase). This positive effect is, however, was reduced in a dose-dependent manner as the concentration of NaCl increased in the media. Production of lovastatin in 2 g/L of NaCl produced no significant difference with negative control while the highest concentration of NaCl (4 g/L) significantly reduced the production of lovastatin at day 6 (31% decrease). The positive effect of NaCl was more obvious in (+)-geodin and sulochrin production, which was significantly induced at both 1 and 2 g/L of NaCl.

It is likely that NaCl influence metabolites biosynthesis by regulating the osmotic pressure [71] of the cells or metal ions supplementation [55]. However, it is unlikely that sodium ion is responsible for the changes in the metabolite production, at least directly, since it is known that this cation is relatively inert [71]. Furthermore, no significant growth and substrate uptake inhibition took place (Table 3), which are among of the mechanism of sodium ion inhibition [104]. Therefore, the change of osmotic pressure is most likely the reason for the change, as also reported in *A. niger*

[71]. The reduction of water inside the fungal pellet may also induce physiological changes, such as enhanced membrane permeability and enzyme synthesis [105,106]. However, the excessive osmotic pressure may cause adverse effects, such as osmotic plasmolysis [107,108]. This effect was observed when 4 g/L of NaCl was added, as the fungal pellet swelled (larger diameter, with lower density) with some cell lysis observed (Table 4.3). The lysis was also probably the reason for the lower glycerol consumption (Table 4.3). This observation also supports the hypothesis that the production of (+)-geodin and sulochrin being a stress-response mechanism as observed in CG experiment, as higher increase was more prominent in both metabolites (at 1 and 2 g/L, refer to Figure 4.5). This result shows that the presence of 2% NaCl in CG is not the factor that reduces metabolite synthesis by *A. terreus*. It is possible that other uncharacterised salts inside the CG are responsible for the inhibition of metabolite production by *A. terreus*.

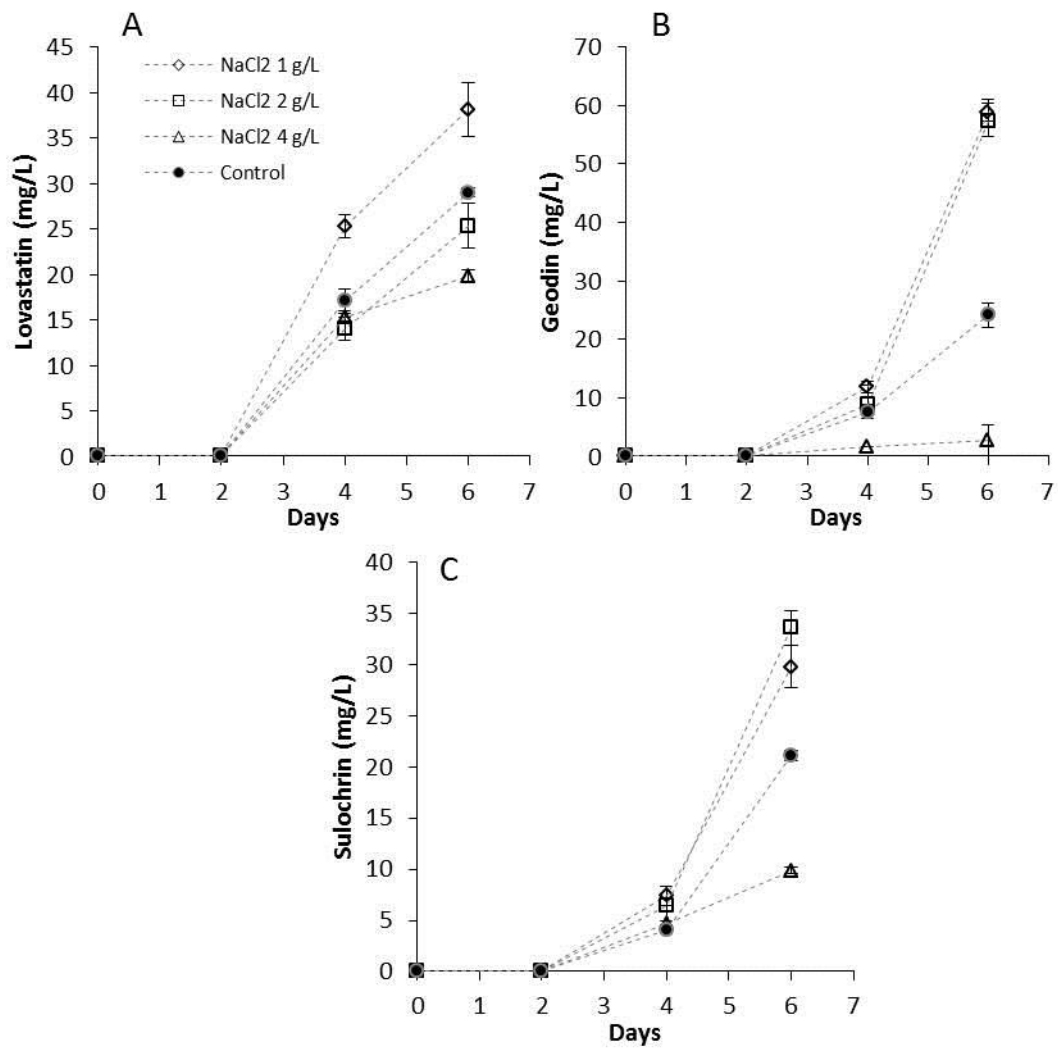

Figure 4.5: **Effect of NaCl addition on the metabolite production of *A. terreus*.** A) Lovastatin was induced significantly at 1 g/L of NaCl. In B) and C), (+)-geodin and sulochrin were both induced significantly at 1 and 2 g/L NaCl. Significance is when  $p < 0.05$ .

	<b>0 g/L</b>	<b>1 g/L</b>	<b>2 g/L</b>	<b>4 g/L</b>
<b>Biomass (g/L)</b>	10.5 ± 0.3	10.6 ± 0.6	10.0 ± 0.5	11.2 ± 0.6
<b>Consumption rate (GLY/l/h)</b>	0.50	0.49	0.48	0.41
<b>Diameter of pellet (mm)</b>	3.0 ± 0.06	3.0 ± 0.09	3.0 ± 0.1	3.4 ± 0.06

Table 4.3: **The effect of NaCl on biomass concentration and glycerol consumption rate in shake flask experiment at 6 days.** The glycerol consumption rate is reported at 2 days due to the near complete conversion of glycerol at day 4. 95% confidence is used as the standard error.



#### **4.2.3 Effect of fatty acids on metabolite production by *A. terreus***

The amount of fatty acids in CG can vary with the source of feedstock used in biodiesel production and is detectable by the presence of a black layer on top of the CG solution. For these experiments, oleic acid (OA) and palmitic acid (PA) were selected to represent single (saturated) and double bonded (unsaturated) fatty acids, while the collected soap from CG will represent the total amount of fatty acids salt.

The biomass and carbon consumption profile for all three treatments are shown in Table 4.4. For all treatments, the biomass growth increased as concentration of fatty acids increased, although the increase was more pronounced when OA is present. In contrast, decreased glycerol consumption was observed in all treatments when compared to the control experiment. It is likely that these fatty acids are consumed as an alternative carbon source [109,110], as these fatty acids administration increased the biomass growth, and reduced the carbon consumption rate.

The amount of lovastatin produced following treatment with selected fatty acids and soap is presented in Figure 4.6. Interestingly, OA addition induced lovastatin production only at the highest concentration used (3 g/L), while the addition of PA significantly reduced lovastatin production in a concentration higher than 0.3 g/L (>56%). On the other hand, the addition of soap significantly suppressed the production of lovastatin at all concentration (the lowest being 74%). However, the most noticeable effect was observed in (+)-geodin production, where all OA additions significantly increased (+)-geodin's production with 3 g/L OA increased (+)-geodin by nearly 6-fold. The increase can also be observed in sulochrin, although the increase was not as substantial as (+)-geodin (~2-fold). However, the presence of PA gave the opposite effect, such that it repressed (+)-geodin and sulochrin production at all concentrations. The addition of

soap (0.3 and 1.5 g/L) produced comparable (+)-geodin and sulochrin compared to the PG control, although the high amount of soap (3 g/L) reduced both (+)-geodin and sulochrin by almost 2-fold.

<b>Treatments</b>	<b>Concentrations (g/L)</b>	<b>Biomass (g/L)</b>	<b>Consumption rate (GLY/l/h)</b>
<b>Soap</b>	0	10.5 ± 0.3	0.50
	0.3	10.4 ± 0.2	0.49
	1.5	10.5 ± 0.4	0.44
	3	12.2 ± 0.5	0.39
<b>OA</b>	0	9.5 ± 1.2	0.43
	0.3	9.7 ± 1.1	0.40
	1.5	10.1 ± 1.4	0.35
	3	13.0 ± 1.4	0.32
<b>PA</b>	0	9.5 ± 1.2	0.43
	0.3	10.9 ± 1.8	0.41
	1.5	12.1 ± 2.4	0.37
	3	14.8 ± 1.2	0.36

Table 4.4: **The biomass and carbon consumption profile of *A. terreus* in the presence of different types of fatty acids.** The production of biomass was either unchanged or increased in the presence of all treatments, while the consumption rate was reduced in all treatments.

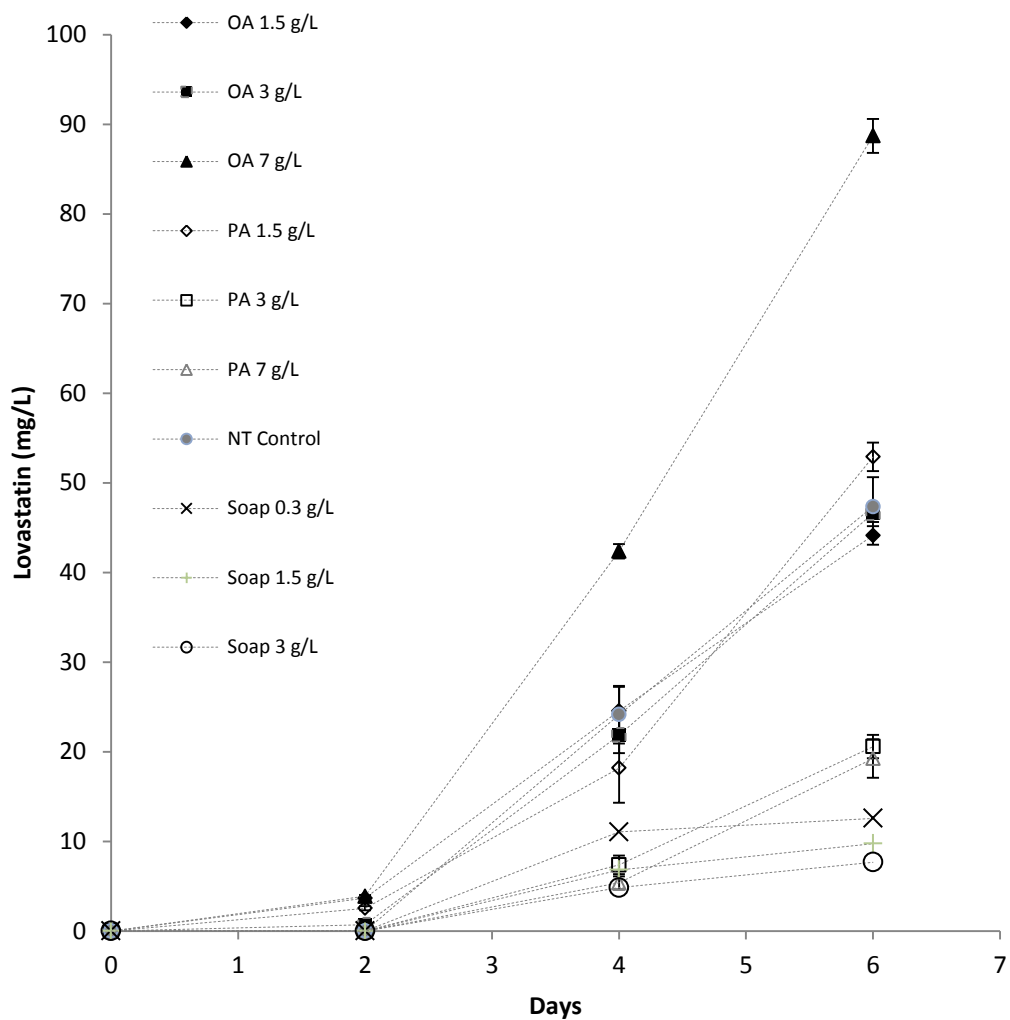

Figure 4.6: **Effect of fatty acids addition on lovastatin production of *A. terreus*.** The lowest concentration of OA did not give any effect on lovastatin production, while 3 g/L induced lovastatin production significantly. The addition of PA greater than 1.5 mg/L caused significant inhibition of lovastatin production. Soap caused greater inhibition of lovastatin than any other fatty acids. A value of  $p < 0.05$  is considered significant.

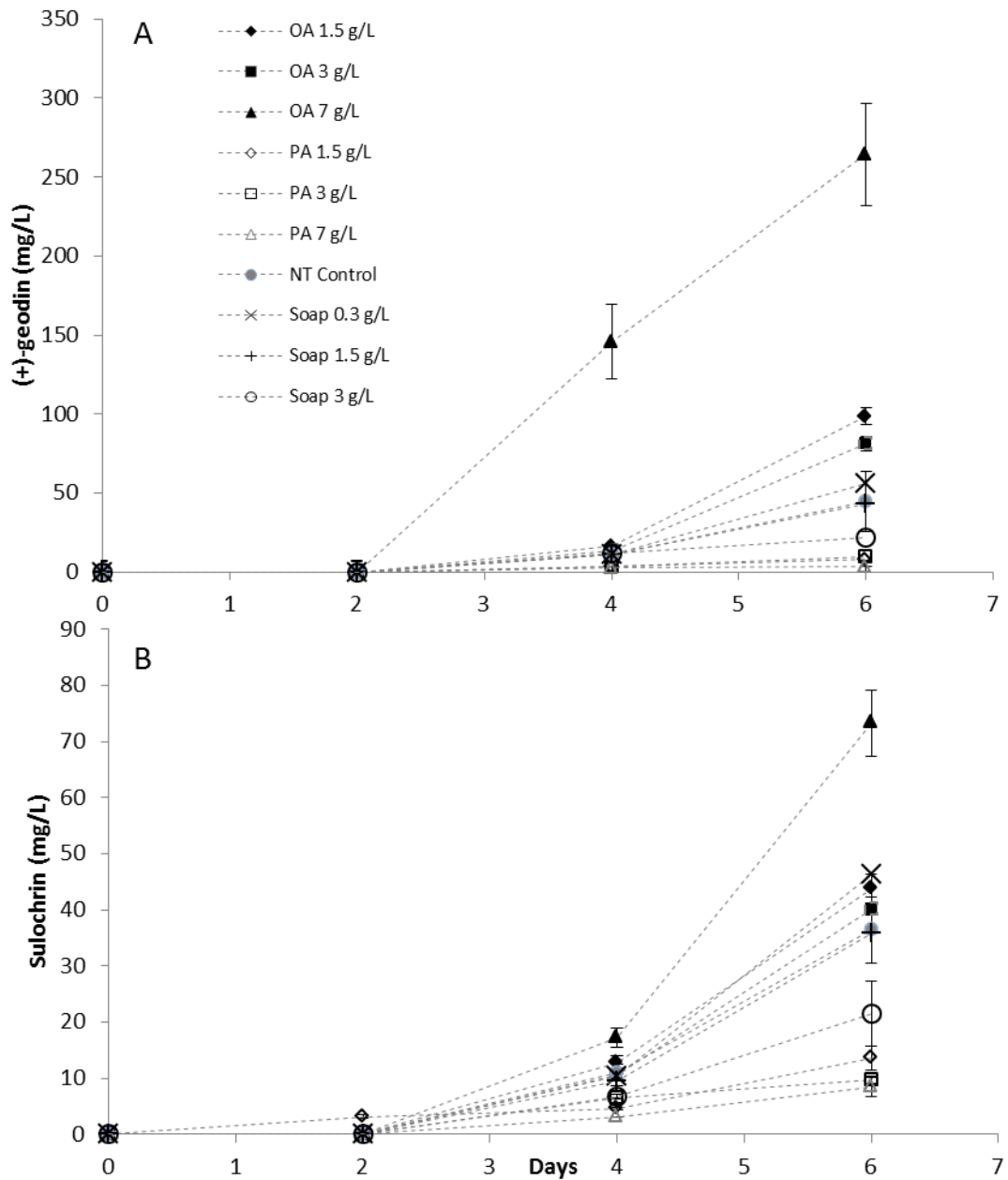

Figure 4.7: **Effect of fatty acids addition on (+)-geodin and sulochrin production of *A. terreus*.** The production of (+)-geodin at 3 g/L of OA was significantly higher than any other metabolites, peaking at 265 mg/L on day 6. The production of (+)-geodin and sulochrin under the presence of PA were significantly suppressed. Only mild inhibition of (+)-geodin and sulochrin were observed in soap-treated media. Only 3 g/L of soap produced significantly lower metabolites compared to the control experiment.

The benefit of double bonded fatty acids on fungi has been previously reported to improve cell signalling, membrane cell structure and the growth of the fungus [86,111–114]. Saturated fatty acids, on the other hand, were shown to inhibit *Aspergillus spp.* metabolite production, possibly by penetrating the lipid membrane of the fungi and caused metabolic uncoupling [115]. Soap has been demonstrated to reduce the metabolite production via a few different routes. The inhibition may occur by the absorption of certain fatty acids (C18) by the microorganism [116] or due to the complex interaction of soap with the membrane of the organism [117]. This experimental result suggests that although unsaturated fatty acids, such as OA may be present in the soap, its stimulatory effect on lovastatin production might be masked by saturated or other type of fatty acids inside CG. As (+)-geodin and sulochrin production was not severely affected by the presence of soap, the benefit of OA in CG is probably one of the major factors that stimulate its production as observed in CG experimental results. Besides, MONG, which primarily comprise of fatty acids, constitutes a large portion (~20%) of CG component use in this study. Hence, the overall trend metabolite production by *A. terreus*, when CG was used, is most likely influenced by the presence of fatty acids or soap.

We observed a different trend of metabolite production in a bioreactor, which would be discussed in the following section.

### 4.3 Metabolite production in bioreactor

The concentration of CG or PG used in bioreactor experiments was 30 g/L, which was chosen based on data obtained from shake flask experiments. Figures 4.8a show glycerol consumption and biomass production for up to 7 days. Consistent with our observations in shake flask experiments, CG showed reduced glycerol consumption compared to PG. Glycerol was completely exhausted by day 3 in PG, but this was delayed in CG until it was exhausted at day 4. The quality of substrate also has little effect on the growth of *A. terreus*. The final biomass obtained from PG (6.3 g/L) and CG (6.0 g/L) was not significantly different ( $p < 0.05$ ), indicating that *A. terreus* was able to produce comparable biomass to PG, when CG was used as the substrate. The only difference observed was the structural integrity of pellet. Instead of spherical and fluffy pellet, noticeable breakage and disintegration of the pellet was observed in both PG and CG experiments, due to the effect of the shear force of the bioreactor. Overall, these observations follow and confirm the experimental data obtained from shake flask experiments in the previous section.

The metabolite production of *A. terreus* in bioreactor showed a higher production of lovastatin, as opposed to shake flask experiment, as shown in Figure 4.8B. Lovastatin in PG (52.25 mg/L, day 6) was shown to be significantly higher than shake flask experiment (shake flask = 19.48 mg/L, day 6). No significant changes in lovastatin production was observed when CG was used (14.48 mg/L versus 10.07 mg/L, day 6). This observation suggests that lovastatin production from PG can be greatly enhanced with better oxygen and aeration control that is possible in a large-scale application such as bioreactors. The main differences in bioreactor experiments compared to shake flask experiments, particularly when PG was used as the substrate, were the production of

(+)-geodin and sulochrin as shown in Figure 4.8b. Up to 67.89 mg/L and 35.55 mg/L of (+)-geodin and sulochrin were obtained, respectively, using the bioreactor when using PG. This rise was equivalent to 838% and 308% rise compared to shake flask experiment, respectively. This particular result is interesting for a few reasons. First, only low production of (+)-geodin and sulochrin were detected in shake flask experiments, whereas they were expressed at a greater concentration in a bioreactor. Second, the (+)-geodin production was very high, but the production of sulochrin did not increase as much (Previous chapters have shown that these two metabolites usually share the same pattern of production). Third, and perhaps the most important, is the significant increase in (+)-geodin at day 4, which corresponded with the disintegration of pellet due to the shear stress resulting from oxygen bubbling and the contact with Rushton-type impeller. In addition, as the culture aged, the media turned dark brown, indicating an increase in metabolites production (see Figure 4.9). This colour change was also observed by Bizukojc M. et al. in their experiment [60], which was attributed it to an increase in lovastatin production. However, such change with an increase in lovastatin production was not observed in our hands in shake flask experiment. Therefore, we are inclined to believe that the colour change may be caused either by an increase in (+)-geodin or sulochrin production.

Conversely, the production of (+)-geodin and sulochrin in CG did not differ as much as its shake flask counterparts. Nevertheless, the production of (+)-geodin was observed to increase after day 4 when similar breakage of the pellet was observed. Such low metabolite production, when CG (see previous paragraph for comparison) was used, may occur due to the higher assimilation of impurities in the culture into the cells as a result of constant stirring and dissolved oxygen content. The increase of lovastatin, (+)-geodin and sulochrin in PG was as a result of better cultivation conditions, such as

improved oxygen control and superior aeration in bioreactor [36]. Given that the two compounds require oxygen in the post-modification steps, higher oxygen levels in bioreactor may favour and enhance their production. However, the production of (+)-geodin is possibly affected by another factor – the integrity of fungal pellet. This fact is proven by the increase of this metabolite as the integrity of fungal pellet was compromised by mechanical force. Again, this result indicates a possible role for these metabolites, especially (+)-geodin and sulochrin, in responding to stress. This factor is explored further in the next chapter (Chapter 5).



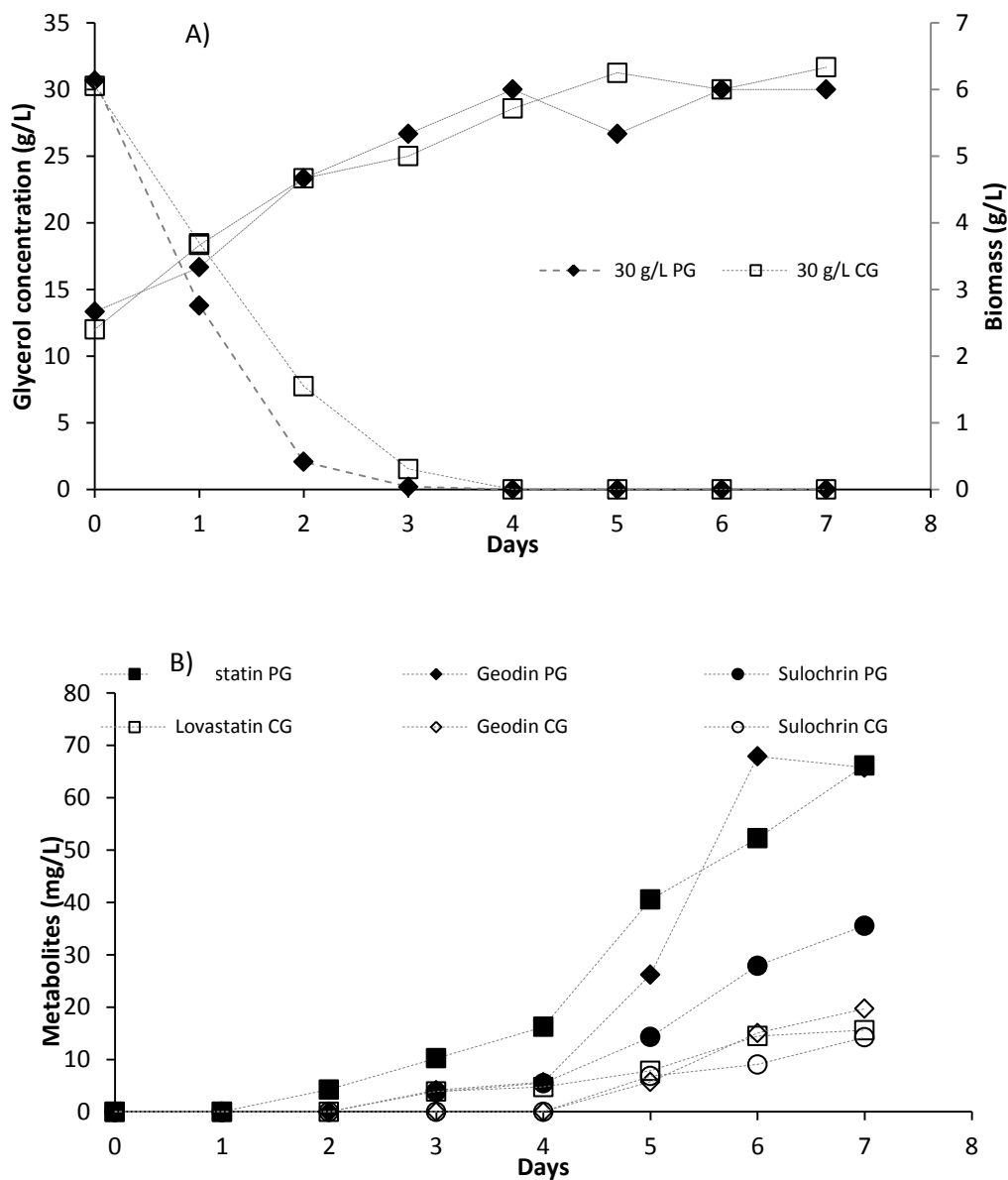

Figure 4.8: **The effect of PG and CG glycerol on metabolite production by *A. terreus* cultivated in bioreactor over 7 days.** The initial glycerol concentration was 30 g/L. From top: A) Glycerol consumption and biomass production and B) Metabolites production. In (A), the quality of glycerol did affect the glycerol consumption but not biomass production. In (B), the overall metabolites production quantity was improved in PG, but not in CG. (+)-geodin's production showed an interesting trend in PG, as a significant increase was observed starting at day 4.



Figure 4.9: **The gradual change of colour observed during the cultivation of *A. terreus*.** The images were taken in every two days, up to day 8.

#### **4.4 Pre-treatments strategy to improve Crude Glycerol utilisation by *A. terreus***

Microbial bioconversion is often more efficient when using a defined carbon source with low content of inhibitory compounds. Apart from what we have discussed in the earlier sections, we investigated the pre-treatments of CG used in this investigation using non-polar solvents, activated carbon and water softener pillow. The treatments produced a noticeable change in the colour and physical appearance of CG, as shown in Figure 4.10. The chemical changes following pre-treatment of CG are discussed in the next few subchapters.

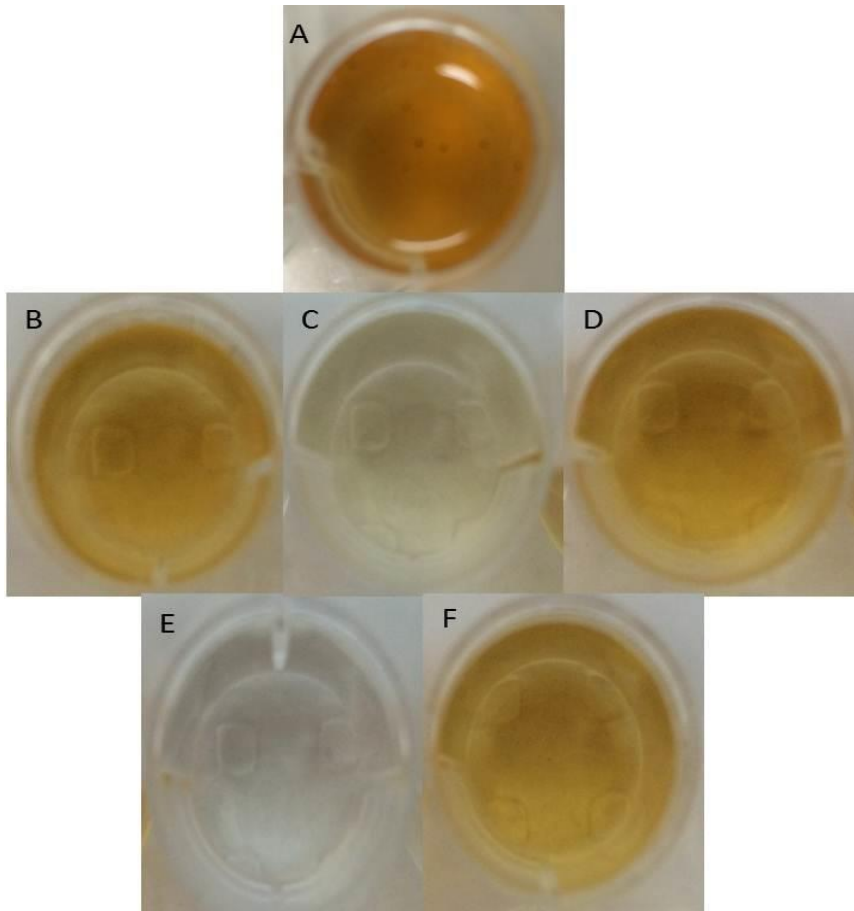

Figure 4.10: **The pre-treatments produced different colours on the CG.** (A) Untreated crude glycerol in deep yellow. (B) Lighter yellow produced from petroleum ether treatment. (C) Lighter yellow from toluene treatment. (D) Lighter yellow from diethyl ether treatment. (E) Almost clear solution from activated carbon treatment. (F) Lighter yellow from water softener pillow treatment.

#### **4.4.1 Comparison between the growth, substrate consumption and metabolite production using crude, pure and non-polar solvent pre-treated glycerol**

Solvent washing is a simple method of separating a compound based on the different solubilities of two immiscible liquids. This method is efficient in reducing certain fatty acids in the solution [118]. By extracting of the impurities from the CG to the organic solvent of interest, we can improve the overall quality of the CG. In our investigation, we opted to use petroleum ether (PE), diethyl ether (DE) and toluene (Tol) as our solvent of interest. Rehman et. al (2008) was among the first team to use this technique on CG, achieving a good microbial bioconversion [119].

As depicted in earlier investigations, the growth of *A. terreus* had a little change (~3%) when the negative control (CG) was used compared to the positive control (PG). The use of pre-treated solvents produced good biomass, which was comparable or exceeded that observed with PG (Table 4.5). DE showed the highest biomass production (11.28 g/L), followed by PE (10.60 g/L), PG (10.07 g/L), Tol (9.80 g/L), and CG (9.75 g/L). The high production of biomass was thought to result from the residual fatty acids that are still present in pre-treated CG, given that the solvent washing cannot entirely remove them from the solution [118]. The increase in biomass in the presence of fatty acids has been discussed previously (Section 4.2.3). The use of pre-treated CG also increased the biomass, although to a lesser extent, indicating that there were probably less fatty acids remaining in the pre-treated CG, compared to what has been investigated in Section 4.2.3 (non-purified CG). Nevertheless, we could not deduce the accurate reasons due to the lack of necessary equipment to analyse the exact composition of CG before and after the treatments.

Treatments	DE	PE	Tol	CG control	PG control
Biomass (g/L)	11.28±0.30	10.60±0.27	9.80±0.22	9.75±0.12	10.07±0.10

Table 4.5: **The biomass production of *A. terreus* under different pre-treatments of non-polar solvents.** The standard errors represent 95% confidence.

Evidently, the pre-treatments of CG with these solvents improved the glycerol consumption significantly (up to 50% improvement) when compared to non-treated CG media (Figure 4.11). This may be possible as a result of the solvent effects in reducing most of the free and methyl ester fatty acids in the CG. However, as discussed earlier in section 4.2.3, we think that the consumption of glycerol in the presence of fatty acids may be lower than PG media due to substrate competition (as fatty acids may probably be the preferable carbon source) or due to the inhibitory effect of fatty acids on carbon uptake.

The production of lovastatin, (+)-geodin and sulochrin using pre-treated CG is depicted in Figure 4.11. PE, in particular, showed an impressive 92.8% increase in lovastatin production at day 6 compared to the PG control experiment. The final titre of lovastatin at day 6 for both DE and Tol, unfortunately, was insignificant to the positive control. Interestingly, a different response was observed in (+)-geodin and sulochrin production. Instead of PE (5.58 g/L), DE (8.95 mg/L) induced (+)-geodin the strongest, while sulochrin is more responsive to Tol pre-treatment (24.78 g/L). This result is still considered excellent nonetheless, because substantial improvement in metabolite production, as well as glycerol consumption, was achieved when compared to the CG (negative) control (Figure 4.11).

The improvement of lovastatin production can be attributed to the ability of the solvent to remove some of the contaminants. Previous investigation showed that certain solvents can remove several key fatty acids in CG, such as linoleic acid methyl ester, palmitic acids and oleic acids [118]. Although some the beneficial fatty acids are also being removed (for example, oleic acid – refer to subsection 4.2.3), the removal of inhibiting saturated fatty acids such palmitic acids was shown to have a larger effect on the lovastatin production by this fungus. It is possible that the induction of lovastatin production in PE is caused by the incomplete removal of unsaturated fatty acids in the treatment. The incomplete removal may also be the reason why we observed a mixed response of (+)-geodin and sulochrin as well (Figure 4.11). The incomplete removal of multiple types of fatty acids in CG provoked different reaction in (+)-geodin and sulochrin, such that higher (+)-geodin was observed in DE treatment (8.95 mg/L), while higher sulochrin was detected in Tol (24.78 g/L). It might be that each of these metabolites is induced more strongly by different impurities, which resulted in a unique response in different pre-treatments (further discussed in Chapter 6: Future Direction).

To investigate further, a subsequent investigation involving the complete removal of fatty acids using soap precipitation technique on CG was conducted (describe in Chapter 2: Materials and Methods). This technique yielded even higher lovastatin production, up to 2-folds (63.25 mg/L). Interestingly, the production of (+)-geodin and sulochrin was suppressed (very little to non-existent), similar to that observed in MeOH's investigation (Section 4.2.1). It is possible that the suppression of (+)-geodin and sulochrin was partly contributed by contributed by other impurities, such as MeOH, which was still present in the treated CG.

It is important to note that the authors of the study stressed the differential effect of pre-treatments when the different source of CG was used [118]. Therefore, it is possible that while the pre-treatments might be effective in one type of CG, it might not be so useful in other type of CG. Hence, a standard method should always be performed to achieve the optimal result in purifying a particular CG.

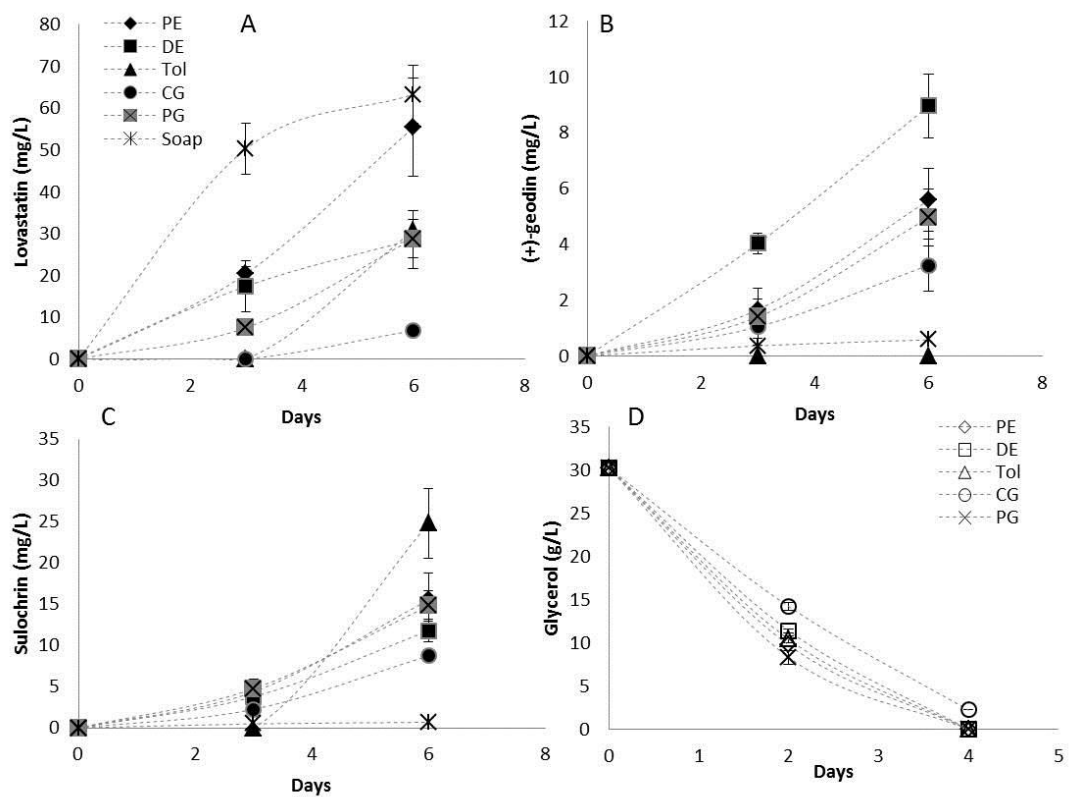

Figure 4.11: The glycerol consumption and metabolite production of *A. terreus* when under different solvent pre-treatments. (A) Lovastatin production is the highest at day 6 in PE treatment and in the absence of soap. (B) (+)-geodin production is the highest in DE treatments at day 6. (C) Sulochrin production is the highest in the Tol treatment at day 6. (D) The consumption of CG is the slowest compared to all treatments. The negative control is represented by an untreated CG while positive control is PG.



#### **4.4.2 The efficiency of non-liquid pre-treatment technique of crude glycerol on substrate consumption, growth and lovastatin production**

In our previous investigation, we used solvent extraction to improve the quality of CG. In this section, we are trying to use solid substances to improve CG and *A. terreus* fermentation. Our substances of choice are activated carbon (AC) and water softener pillow (WS). AC is a form of carbon material that has been treated with oxygen by thermal decomposition to create millions of pores that increase the surface area available for absorption. While solvent washing involved the reduction of impurities by transferring the impurities from one liquid to another, AC concept is about the trapping and filtering of the impurities inside the CG. On the other hand, the aim of using WS is to reduce the “hardness” of the solution, which is the indication of the presence of minerals, such as calcium and magnesium. While there is no evidence that associate the effect of hard water on the growth or production of metabolites by fungus, recent evidence showed that divalent metal cations can influence lovastatin biosynthesis [55]. Moreover, the presence of certain metal ions together, in certain concentrations, may be potentially inhibitory to lovastatin production.

Our initial analysis addressed whether the treatments would alter the composition of glycerol inside CG. However, the post-glycerol analysis showed a little change of glycerol, which indicates that the treatments did not interfere with the glycerol content (less than ~2% differences). The CG treated using solvent washing, and WS did not really change in their physical look, but AC treatment produced a clear and odourless solution which is comparable to that of PG (refer to Figure 4.10).

Our subsequent analysis showed an improvement in term of substrate consumption when compared to CG when AC and WS (42% and 22% improvement, respectively at

day 2) was used (Figure 4.12). However, no improvement in biomass growth was detected under both treatments. The higher rate of improvement when AC was used indicated that this technique is probably more beneficial to the fungal growth, most likely by improving the flux of substrate into the fungal cell. This observation also indicates that the reduction of cations (by reducing the water hardness using WS) would still improve the consumption, but is probably limited by the presence of non-dissolved solids inside the CG.

Figure 4.13 shows the production of lovastatin, (+)-geodin and sulochrin using either non-treated CG or CG pre-treated with AC, WS, PG and CG for 6-days cultivation. The production of lovastatin (21.80 mg/L), (+)-geodin (7.43 mg/L) and sulochrin (11.74 mg/L) following AC treatment was very similar to PG (20.65 mg/L, 8.60 mg/L and 8.18 mg/L, respectively). In contrast, WS' metabolite productions ( $C_{LOV} = 11.25$  mg/L,  $C_{GEO} = 12.34$  mg/L,  $C_{SUL} = 12.85$  mg/L) mirrored CG ( $C_{LOV} = 7.10$  mg/L,  $C_{GEO} = 17.10$  mg/L,  $C_{SUL} = 14.78$  mg/L). This suggests that the AC treatment produced almost "pure" substrate, comparable to PG, while WS treatment failed to improve the quality of the cultivation given that its production pattern resembles that of CG. These observations also support our earlier observation on the effect of these treatments on glycerol consumption, where AC treatment proves to be the best treatment between those two. As expected, WS treatment and CG control produced higher (+)-geodin and sulochrin due to the higher presence of impurities. This observation, again, supports that (+)-geodin and sulochrin are more responsive towards impurities, and may be indicative of their role in stress-related mechanism in *A. terreus*.

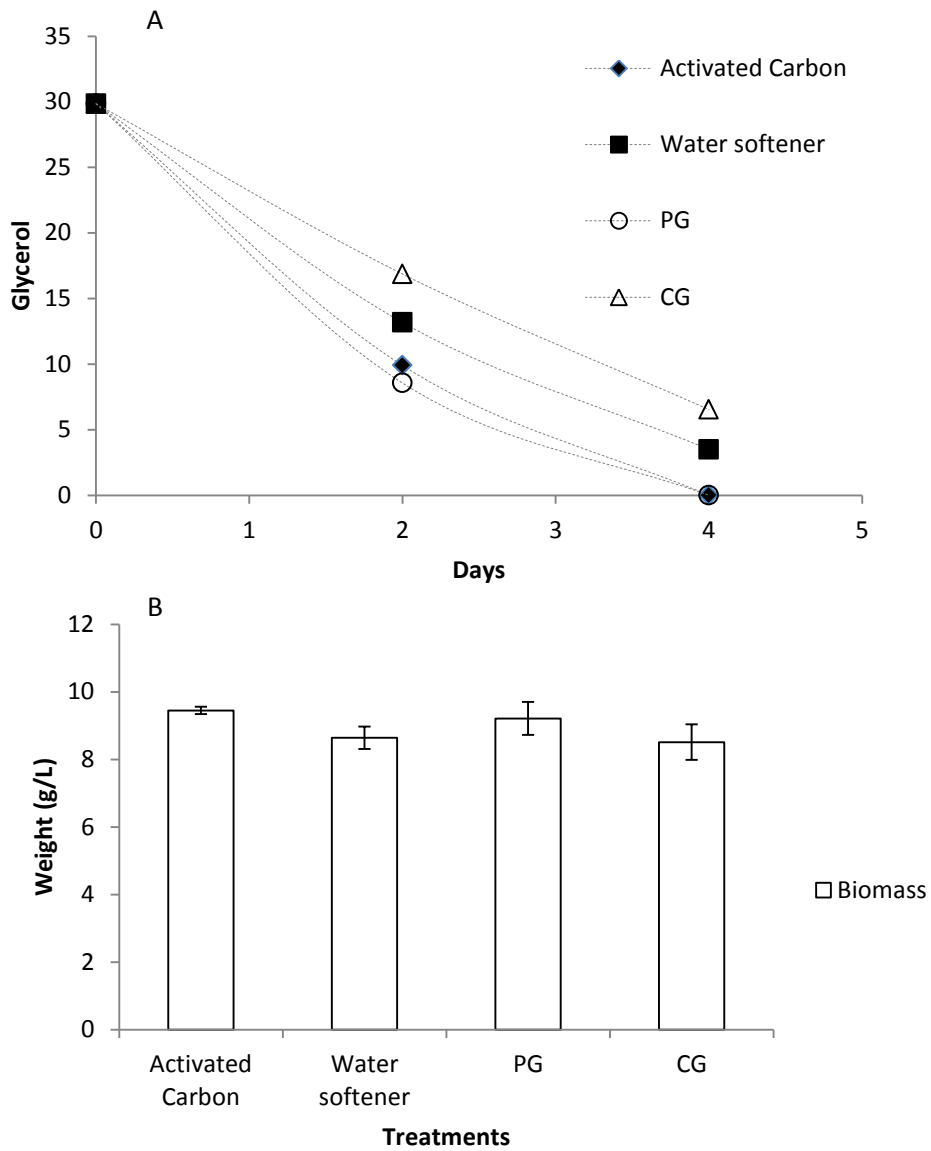

Figure 4.12: **The glycerol consumption and biomass growth by *A. terreus* under the treatment of AC and WS.** A) Glycerol consumption. B) Biomass production. In A), the glycerol consumption in AC improved considerably, similar to positive control. In B), the biomass production was not affected by the pre-treatments.

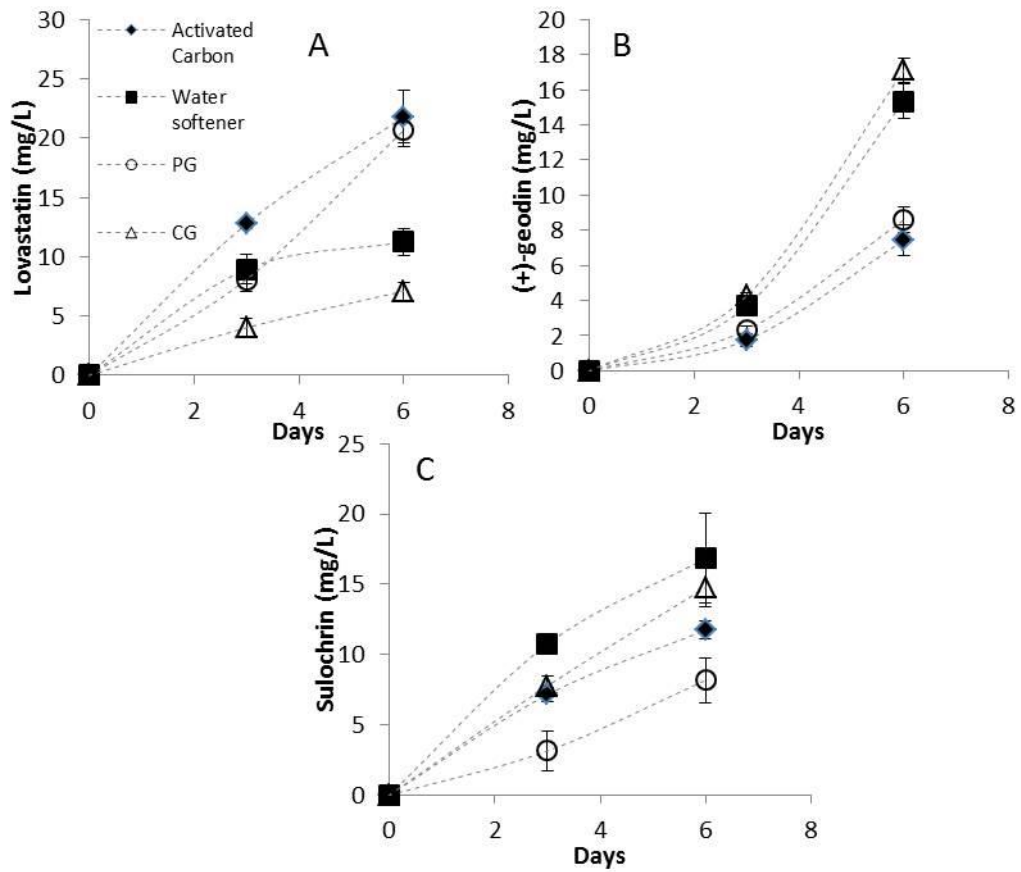

Figure 4.13: The lovastatin, (+)-geodin and sulochrin by *A. terreus* under the treatment of AC and WS. A) Lovastatin production. B) (+)-geodin production C) Sulochrin production. Lovastatin, (+)-geodin and sulochrin production in AC mirrored positive control (PG), while these metabolite production in WS mirrored negative control (CG).

## 4.5 Conclusion

We have shown that *A. terreus* strain can grow and produce metabolites using CG as its carbon source, albeit with a reduced lovastatin production. Based on the experimental data using foreign substances found in CG, we concluded that certain type salts (such as sodium phosphate) and saturated fatty acids are the main inhibitor for lovastatin production. While octaketide compounds have been suggested to have a relationship with lovastatin production, we did not observe such relationship, at least with (+) - geodin and sulochrin. Although CG may not be a better carbon source than PG for lovastatin production, it is indeed a promising economic and environmental alternative to make full use of easily accessible bio-wastes.

## **Chapter 5 - Enhancement of metabolite production in *A. terreus* by chemical, biological and natural factors**

### **5.0 Introduction**

In the previous chapter, we found that the production of metabolites can be stimulated by different factors i.e. osmotic pressure, fatty acids and possibly by shear force (in the bioreactor). As CG is a dirty substrate; it is likely that there will be substances that may provoke the fungus' defense system inside CG. This chapter is the continuation of the previous chapter where the possible mechanism of CG and pattern of metabolite production will be investigated by using a known compounds or techniques using the purified CG from AC.

Since the early 1970s, 'elicitors' have been shown to trigger the synthesis of secondary metabolites by stimulating the organism's defense system. This response is part of the microorganisms' normal reaction to so-called 'threat' molecules, usually associated with survival, persistence and competitiveness. An initial elicitation study has been conducted on plant culture system [120]. Since then, the term 'elicitor' has been also used in other organisms, including fungi and bacteria [121]. An elicitor may be present in the form of physical or chemical, biotic or abiotic, and complex or defined, depending on its source and molecular structure (Table 5.1). In fungal cell culture, certain types of complex carbohydrates (oligosaccharides and polysaccharides) are the major sources of biotic elicitors; this includes sodium alginate [122].

Alginates can be classified as linear polysaccharides produced by some bacterial species and brown algae. The main building blocks of alginates are two different hexuronic acids:  $\beta$ -d-mannuronic acid (ManA) and  $\alpha$ -l-guluronic acid (GulA), linked by  $\alpha$ 1-4

bonds [123]. Studies have demonstrated that alginates can trigger the immune system in different organisms, making them an excellent biotic elicitor. In a fungal cell study, alginate treatment improved the activity of the glucose oxidase—a cell marker for defense mechanism—by almost 50% [122]. Furthermore, treatment with alginate and its derivatives induced the major penicillin biosynthetic pathway (pcbAB, pcbC and penDE) in penicillin-producing fungi without changes in fungal biomass [121]. Apart from penicillin, these carbohydrates also stimulate the production of pigments such as chrysogenin in the same family of fungi [124].

Cholesterol may also act as an elicitor for lovastatin production based on its negative feedback mechanism. As discussed earlier in the introduction chapter, lovastatin is a cholesterol inhibitor of HMG-CoA reductase. The production of lovastatin is a result of the defense mechanism of *A. terreus* in response to other organisms that require sterols as their main constituents [13]. This led us to propose that *A. terreus* may have a sensory mechanism to detect any sterol-related compound near its vicinity. Hence, any addition of sterile-related compound could trigger its defense mechanism and consequently induces the production of lovastatin.

The setup of the experimental procedures for the chemical elicitation experiment in this chapter is summarised in Table 5.2:

Elicitors				Organism (s)		
Physical	Injury			P		
Chemical	Abiotic	Metal ions (lanthanum, europium, calcium, silver, cadmium), oxalate		PC		
	Biotic	Complex	Yeast cell wall, mycelia cell wall, fungal spores		PC, F	
		Defined	Carbohydrates	Polysaccharides	Alginate	PC, F, B
					LBG	F
					Pectin	PC, F
					Chitosan	PC
					Guar Gum	PC
				Oligosaccharides	Mannuronate	F
					Guluronate	F
					Mannan	F
					Galacturonides	PC
			Proteins	Peptides	Glutathione	PC
				Proteins	Cellulase, Elicitins, Oligandrins	PC
			Lipids		Lipopolysaccharides	PC
			Glycoproteins		Not characterised	PC
Volatiles		C <sub>6</sub> – C <sub>10</sub>	PC			

Table 5.1: **Compilation of possible elicitors used in different organisms.** Abbreviations used: P – Plants, PC – Plant cell culture, F – fungi, B – bacterial cell culture. Adapted from [121].



Number	Treatments	Concentration		Viscosity (mPA.s)
		mg/L	mL/L	
1		50	NA	300.21
2	Sodium Alginate (SA)	100	NA	713.75
3		200	NA	1100.32
4		75	NA	301.32
5	Gelatine (positive control)	150	NA	708.17
6		400	NA	1113.01
7		50	NA	15.02
8	Alginate without calcium ion (positive control)	100	NA	70.43
9		200	NA	126.96
10		100	NA	NA
11	Cholesterol	500	NA	NA
12		1000	NA	NA
13	Negative control	0	0	4.77

Table 5.2: **Experimental plans to investigate elicitation in *A. terreus*. Each experiment is performed at least in triplicates, using the same spore source to avoid variation.** All elicitors were added after 24 hours of fungal culture initiation. In this chapter, the experiment was performed for 9 days with sampling every 3 days.

In Chapter 4, the production of (+)-geodin was significantly stimulated in a bioreactor system. Fungal cultivation in bioreactor caused the fungal pellet to break, due to the high shear pressure and contact between the Rushton-type impeller with fungal pellets. Therefore, we hypothesised that the production of these metabolites, especially (+)-geodin, is related to pellet integrity. However, Sainz and colleagues reported that [45] sonication suppressed both morphology (by reducing the size) and lovastatin production by *A. terreus*, although no measurement of (+)-geodin and sulochrin was done. In this chapter, the effect of shear pressure (introduced via friction and sonication) or ‘physical elicitation’ on *A. terreus* will be investigated.

Malonic acid is mainly known as a competitive inhibitor of succinate dehydrogenase in the citric acid cycle [125]. *A. terreus* is a complex microorganism that utilises this cycle to produce energy. The introduction of malonic acid may be fatal for this organism due to its inhibitory effects on key metabolism. However, fungi are robust species, and partial inhibition of energy metabolism may increase the metabolite production instead, due to the increased availability of the precursors for metabolite production. In higher organisms, especially plant, malonic acid has been shown to be beneficial due to its conversion into malonyl-CoA, which is an important precursor in all living organisms [126]. Thus, malonic acid might probably be utilised to some extent in fungi species too, as part of their normal metabolism although their specific role is yet unknown.

The setup of the experimental procedures for other stimulatory factors in this chapter is summarised in Table 5.3.

Number	Treatments	Amount/type	
		mg/L	Type
1		100	Chemical
2	Malonic acid	300	Chemical
3		500	Chemical
4	Friction	NA	Physical
5	Sonication	NA	Physical
6	Negative control	NA	NA

Table 5.3: **Experimental design involving other stimulatory factors for metabolite production by *A. terreus*.** All the experiments were performed with a minimal of triplicates. Similarly, all the experiments were performed for 9 days with sampling taken at every 3 days.

## **5.1 Elicitors**

### **5.1.1 Sodium alginate improved lovastatin early in cultivation and induced unique pattern of octaketide metabolite production**

Sodium alginate (SA) can form viscous gum upon contact with water that contains calcium ion, which is part of our media composition. Given that viscosity may influence the production of metabolites by *Aspergillus* species [127], a positive control containing gelatine was used to mimic the viscosity effect of SA. To study the effect of SA without the presence of calcium (thus having low viscosity), a second positive control was set up (SA2).

The biomass production of this culture in SA-treated media and gelatine was higher than that of SA2 and the negative control (Table 5.4). In SA2, only a slight increase in biomass was observed at all three concentrations. Treatment with SA of 200 mg/L and gelatine of 400 mg/L produced the highest biomass increase (44% and 42% respectively). This was then followed by treatments with SA (100 mg/L) and gelatine (150 mg/L), resulting in an increase of 41% and 34.4% respectively. These observations show that viscosity plays a key role in biomass production, but elicitation only play a minor role. Higher biomass production in higher viscosity media is likely to have been contributed by the viscosity-protective effect, as this effect allowed a better distribution and protected the fungal cell from the sheer force of the mixing rate [127]. High viscosity is also favourable for growth in a number of different fungi [42,128,129].

<b>Treatment</b>	<b>Concentration</b> <b>(mg/L)</b>	<b>Biomass</b> <b>(g/L)</b>	<b>Diameter</b> <b>(cm)</b>	<b>Density</b> <b>(g/m<sup>3</sup>)</b>
SA	50	11.2	3.2 ±0.03	0.65
	100	12.7	3.3±0.05	0.68
	200	13.0	3.3±0.06	0.69
Gelatine	75	10.4	3.1±0.06	0.67
	150	12.1	3.2±0.05	0.71
	400	12.8	3.2±0.05	0.75
SA without calcium ion (SA2)	50	9.0	3.1±0.04	0.58
	100	9.5	3.1±0.04	0.61
	200	10.3	3.1±0.05	0.66
Negative control	NA	9.0	2.9±0.06	0.71

Table 5.4: **Biomass, diameter and density of *A. terreus* under different media treatments in the elicitation experiment.** Increasing the viscosity (measured by increasing concentration) contributed to the increase of biomass.

The pattern of lovastatin production is shown in Figure 5.1. Lovastatin production was significantly higher in all treatments with SA compared to the negative control. Treatment with 200 mg/L of SA produced the highest production (329% compared to the negative control), followed by treatment with 100 mg/L of SA, producing a production of 203% at day 9. However, the most notable feature of SA treatment was the timing of lovastatin production. A significant increase in lovastatin production could be observed as early as day 3 (729% increase at 200 mg/L SA), while none yet was produced in any of the controls, which indicates the immediate effect of SA on metabolite production. The rapid onset may be attributed to SA's ability to induce enzyme activity within a short period. For instance, in *Penicillium variable* P16, the increase of enzyme activity was detected as soon as 24 hours after the addition of SA and SA-type elicitors [122].

In contrast to SA-treatment, only slight non-significant improvement in lovastatin production was observed in gelatine-treated media (41.5% at 75 mg/L gelatine, day 2). In fact, high gelatine concentration (300 mg/L) produced lower lovastatin titre ( $C_{LOV} = 6.23$  mg/L) when compared to the negative control (10.86 mg/L). Most likely, the high viscosity media is less optimal for metabolite production due to the decreasing mass transfer, heat transfer and oxygen transfer [130]. However, this finding is in contrast with the observation in *A. niger*, where significantly higher metabolite was produced when higher viscosity media was used in shake flask cultivation [127]. This finding indicates that different fungus may have different requirements for metabolite production. In the aforementioned study in *A. niger*, it was shown that the morphology and metabolite production of this fungal strain were sensitive to shock and agitation speed introduced in their experimental model [127]. The introduction of higher viscosity media protects the morphology of *A. niger*, thus resulted in higher metabolite production. *A. terreus* however, was more resistant to much higher shear force caused by the agitation speed [34]. However, the significant increase of lovastatin production only in the

presence of SA highlights that there is a synergistic effect between viscosity and elicitor, as the SA2 control (without viscosity) produced significantly lower lovastatin than SA-treated media.

Under normal circumstances, the increase of (+)-geodin production was usually followed by a similar rise in sulochrin production (Figure 5.1). This pattern was expected as both metabolites are octaketide compounds derived from the same pathway. However, a different pattern of production for each metabolite was observed in SA and gelatine-treated media. The production of (+)-geodin was suppressed in SA and gelatine, but not in SA2 and the negative control. On the other hand, sulochrin production was increased in SA and SA2. These observations suggest that (+)-geodin production is influenced by the viscosity of the media, while sulochrin production is dependent on the presence of elicitor. A significant increase in (+)-geodin was also observed in the bioreactor (Chapter 4: Crude glycerol) too, when the shear pressure was high. As higher viscosity translates into low shear pressure, this is likely the reason why the (+)-geodin's production was low.

In contrast to lovastatin production, which plateau after day 6, (+)-geodin and sulochrin production showed an active trend up to day 9. Production of sulochrin increased significantly on day 9 when compared to day 6 (previous time point) in all treatments tested. This observation suggests a role of sulochrin as a late metabolite. On the other hand, production of (+)-geodin peaked at day 6, but decreased at day 9. Reduction of (+)-geodin after day 6 might have been caused by the depletion of carbon source towards the end of fungal cultivation [74]. However, the reduction may also occur as a result of degradation, or being consumed by the fungus for its normal function [60].

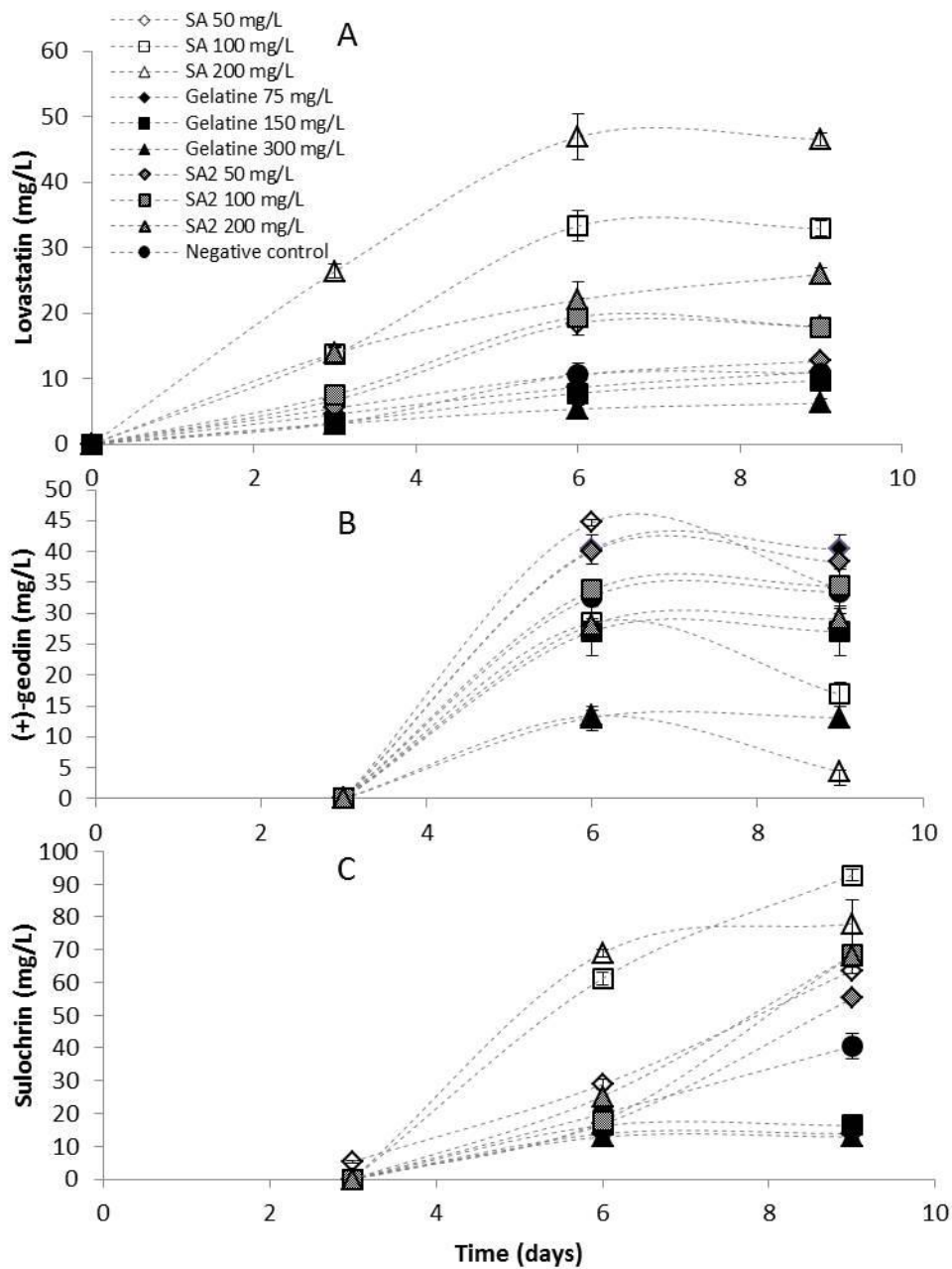

Figure 5.1: **Lovastatin, (+)-geodin and sulochrin production under different media treatments in the elicitation experiment.** The graphs showed A) Lovastatin production, B) (+)-geodin production and C) sulochrin production. Experiments were conducted for 9 days using at least triplicates. Error bars represent 95% confidence interval.



The next part of the study evaluated morphological features of *A. terreus*. All of the pellets exhibited full-grown hair on their surface, which is an early indicator of high lovastatin production in the media [34]. A study by Porcel R. et al. showed that one of the factors that affect the production of hair is the shear force inside the media [33]. By measuring the length of hair (which later is defined as “filament ratio”), they concluded that high shear force might cause retraction of hair into the pellet, which would eventually lead to lower lovastatin production [33]. It is unclear how the length of hair affects lovastatin production. The “presence” of hair, rather than the length, is probably more important as observed by Lopez C. et al. [34]. In addition, it has been found that the pellet with hair, which exhibited soft, loose and less dense structure, is also optimal for lovastatin production [33].

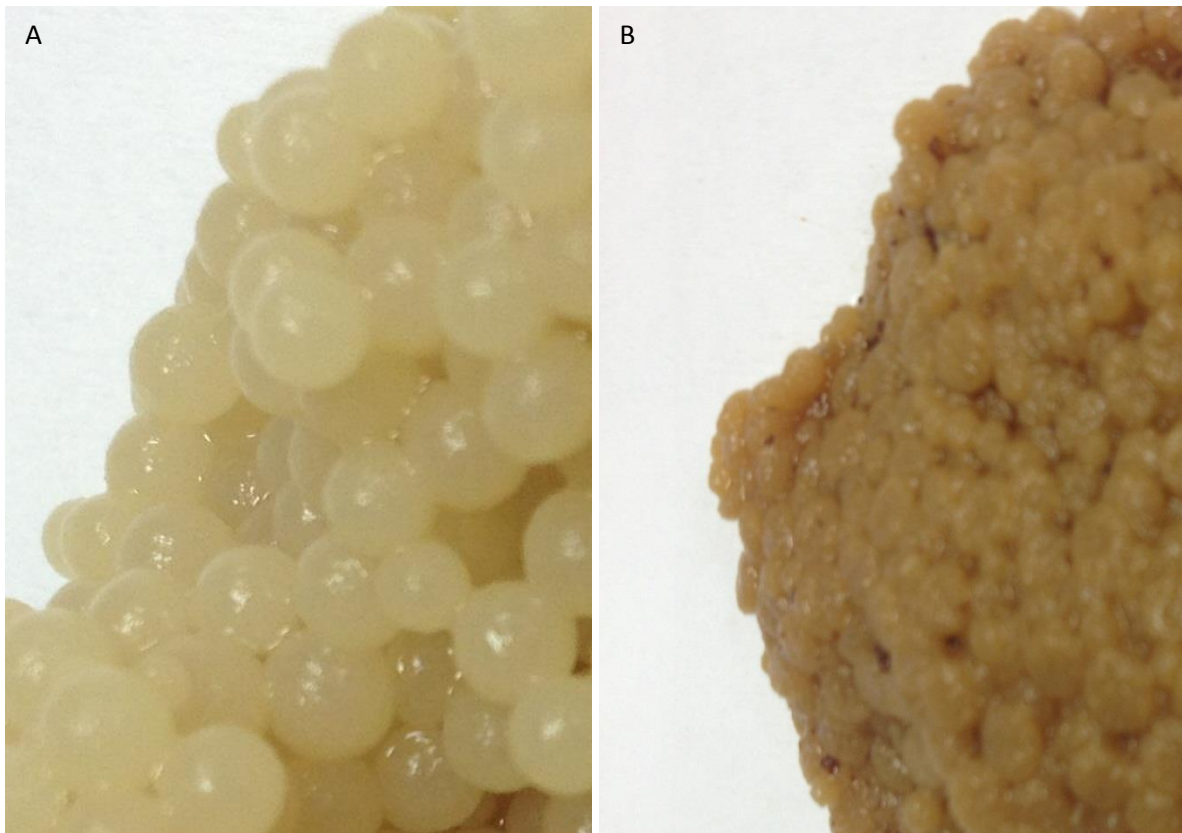

Figure 5.2: **The morphology of pellets commonly observed in *A. terreus* cultivation.** The presence of hair is usually associated with soft, loose, and less dense pellet (in B) compared to the hairless pellet (in A), with the tendency to clump.

The carbon (glycerol) consumption profile of *A. terreus* also showed an interesting trend (Figure 5.3). The consumption of glycerol in SA, gelatine and SA2 were all higher than the negative control, but not significantly different from each other. The introduction of viscosity is most likely improved the nutrient transfer from the media into the fungus, which improved its consumption capacity [32,131]. As usual, the sharpest decline in glycerol concentration occurred in the first 2 days, due to a higher requirement of carbon sources for growth and metabolite production.

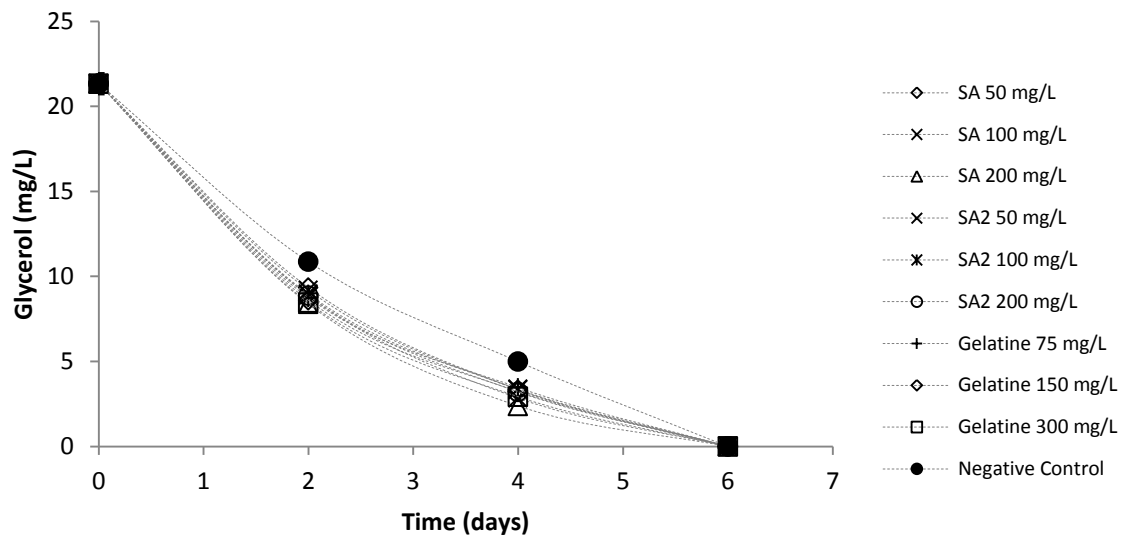

Figure 5.3: **Glycerol consumption by *A. terreus* under the addition of elicitors over the period of 9 days.** All treatments, as well as the positive control, showed an improvement in substrate consumption compared to the negative control.

### 5.1.1.1 Confirmation of Sodium Alginate as elicitors using bacteria

Another investigation was set up to confirm the role of SA as an elicitor. In several batches of experiments, the pre-culture media (with fungal spore in it) was contaminated by unidentified bacteria (Figure 5.4), most likely from the bacillus species, identified from its rod-shape morphology under a light microscope. The contamination is easily spotted by its foul-smelled, muddy solution with the presence of dwarfed pellets after 24 hours. It is hypothesized that this bacterial species would provoke the defense system of *A. terreus* similar to SA.

Initial optimization experiment indicated that *A. terreus* cannot compete with this bacterium during the first 48 hours of cultivation. However, the addition of any bacteria stock after 48 hours did not give any physical changes or further contamination on the fungal pellet. This observation indicates that the fungus has been most likely matured enough to ward off contaminations after certain stages of growth.

The production of metabolites using bacteria as elicitor is depicted in Figure 5.5. The metabolite production response bore a very close resemblance to the production of metabolites when SA was used, particularly with lovastatin and sulochrin. This pattern confirms that both metabolites produced as a response to elicitation. The initial increase in lovastatin production that was observed in SA during the initial cultivation was also evident when bacteria was used. (+)-geodin's production, however, is more similar to control's production which suggested that viscosity is more related with (+)-geodin's production.

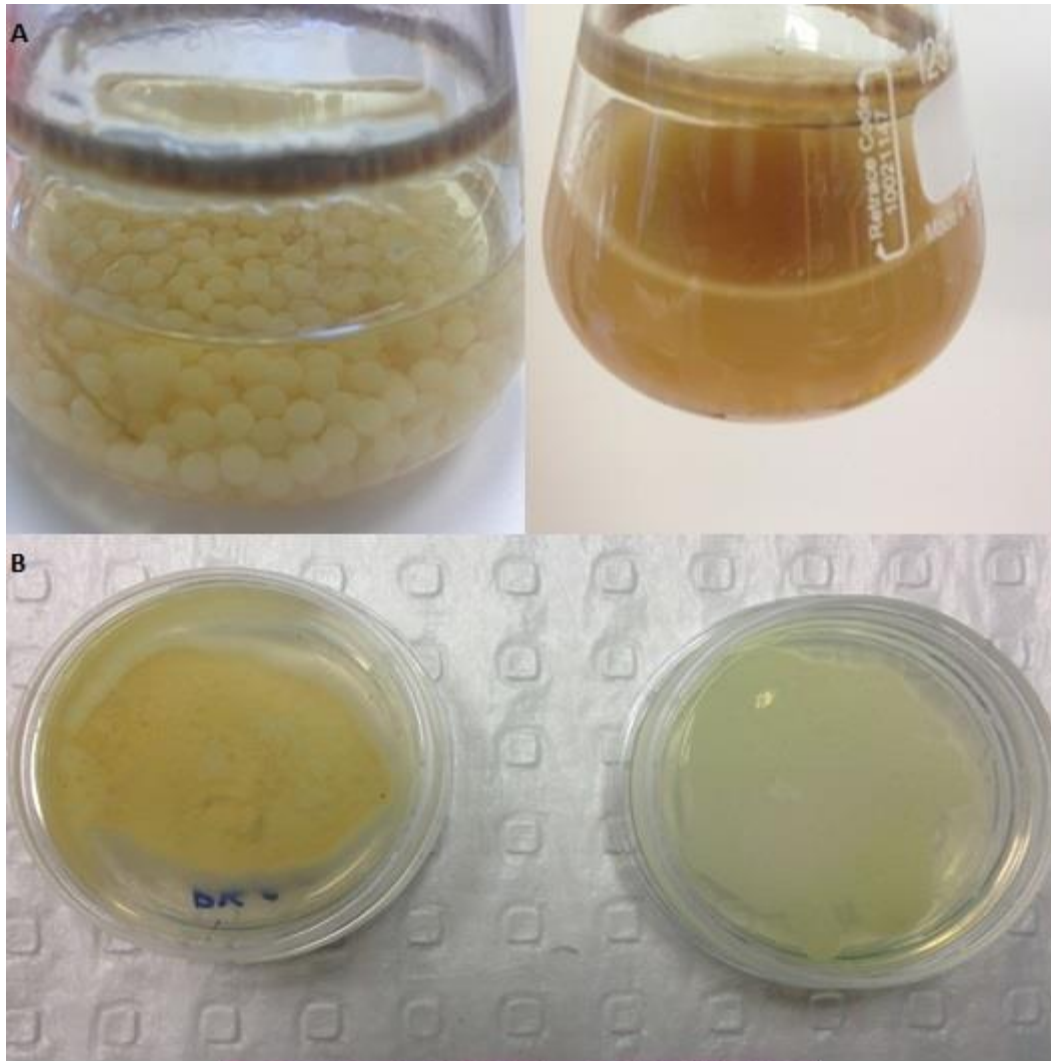

Figure 5.4: **The contamination and subsequent isolation of the contaminating bacterial strain.** From top: (A) Differences between non-contaminated (left) and contaminated (right) culture of *A. terreus*. (B) Subsequent culture on PDA plates showed the growth of *A. terreus* (left) and bacteria (right).

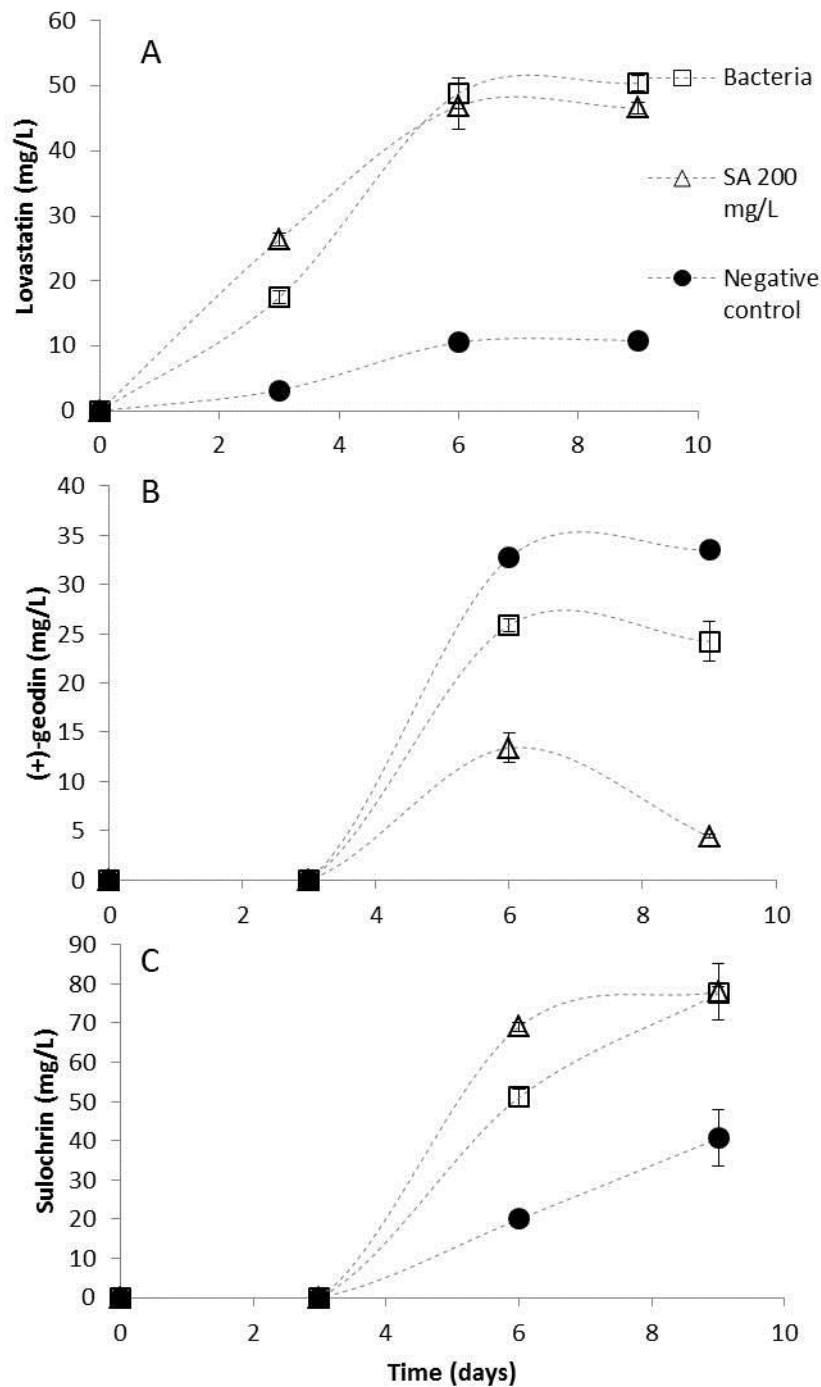

Figure 5.5: **The metabolite production profile of *A. terreus* with the addition of bacterial stock after 48 hours.** The lovastatin and sulochrin production follow a similar pattern with SA, while (+)-geodin production closely resembles control experiment. The graphs showed A) Lovastatin production, B) (+)-geodin production and C) sulochrin production.

### **5.1.2 Cholesterol induces metabolite production by improving the overall growth rather than inciting defense mechanism of *Aspergillus terreus***

The metabolite production of *A. terreus* under different concentrations of cholesterol is illustrated in Figure 5.6. The addition of cholesterol increased lovastatin production at all concentrations tested. However, the increase was insignificant at day 3 in a non-concentration-dependent manner. Only at day 6, the difference became clear, as an increase of 63.6% and 77.40% in lovastatin production was observed in 1000 mg/L and 500 mg/L of cholesterol, respectively, while lowest addition of cholesterol (100 mg/L) of cholesterol did not produce any noticeable difference compared to the negative control. This suggests that unlike elicitors (e.g. sodium alginate), the effect of cholesterol is not immediate, and therefore may not act as an elicitor. This, however, can only be confirmed by measuring the gene expression and carbon flux of the fungus. (+)-geodin and sulochrin production also showed an opposite pattern compared to the elicitor experiment. This time, both of the metabolites are stimulated together in a concentration-dependent manner at the end of cultivation (day 6), which suggested that the increase of metabolites was fuelled by the increase of cholesterol in the media.

Table 5.5 summarises the effect of cholesterol on substrate consumption and biomass of *A. terreus*. Only a slight improvement in substrate consumption was observed in cholesterol-treated media. Biomass production has been found to increase with increasing concentration of cholesterol, in higher proportion compared to the elicitors experiment. Further analysis of cholesterol quantitation showed a reduction of cholesterol amount in the media by 9.3%, 15.7%, and 12.5% (from 100 mg/L, 500 mg/L, and 1000 mg/L cholesterol respectively) on day 6 of cultivation. The uptake of cholesterol by *A. terreus* has never been documented before, although this has been demonstrated in other filamentous *Aspergillus* species [132].

Recent evidence also showed that sterol-related compound can be transported into the fungi under certain conditions [133]. Cholesterol treatment also produced clear media, with white and fluffy pellets that indicate the optimal morphology for metabolite production. The negative control, on the other hand, produced a brownish and slightly cloudy solution. Hence, the increase of metabolites may be due to the overall improvement of fungal growth, rather than being seen as a threat that would incite the fungus' defense system.



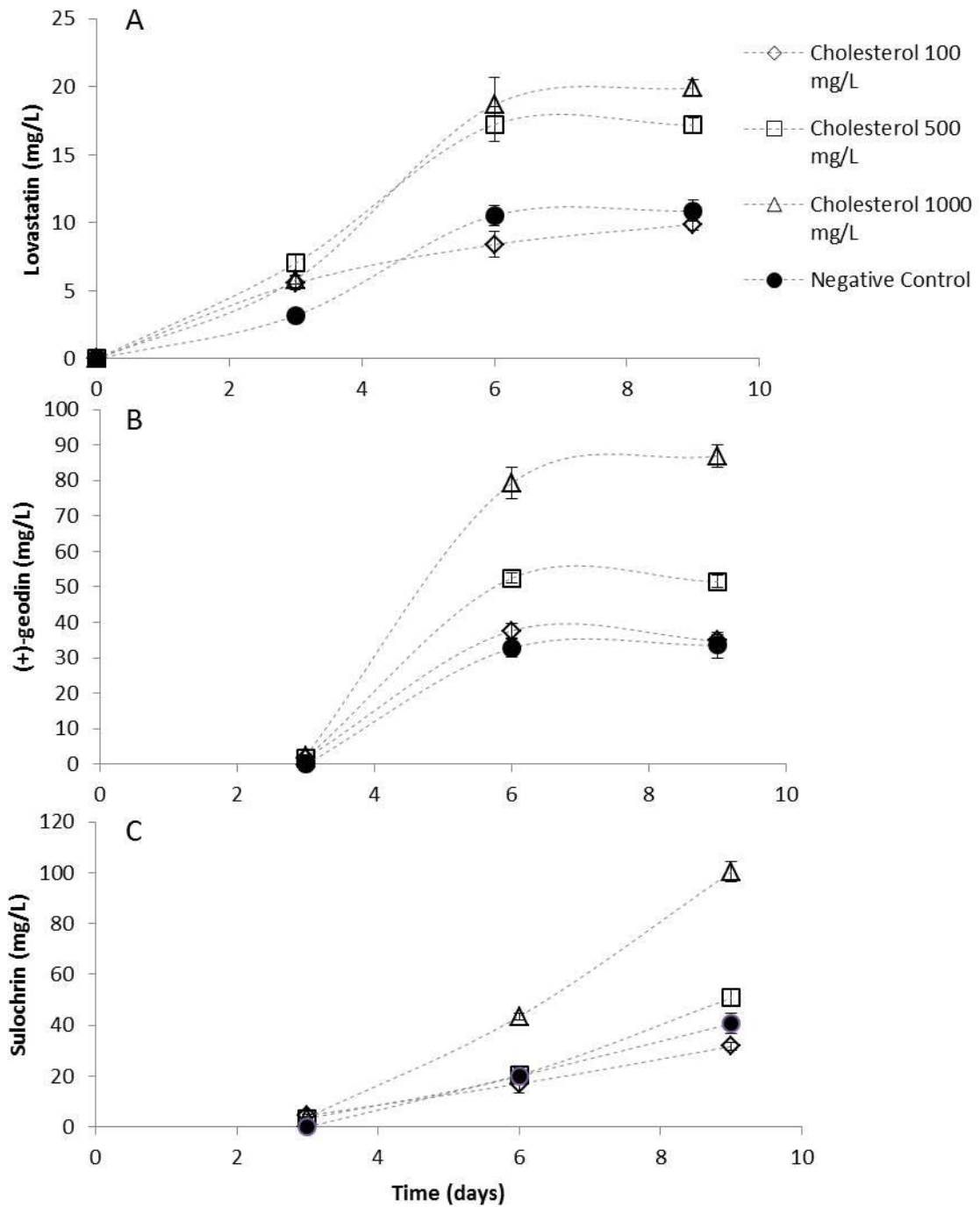

Figure 5.6: Lovastatin, (+)-geodin and sulochrin production in *A. terreus* under cholesterol treatment during 9-day cultivation. The lowest addition of cholesterol (100 mg/L) did not affect the production of any metabolites. The graphs showed A) Lovastatin, B) (+)-geodin and C) sulochrin production.

<b>Treatment</b>	<b>Consumption rate (day 2)</b>	<b>Consumption rate (day 4)</b>	<b>Biomass (g/L)</b>	<b>Diameter (mm)</b>
Cholesterol 100 mg/L	5.08	2.82	11.4±0.1	3.2
Cholesterol 500 mg/L	5.19	2.83	13.4±0.06	3.2
Cholesterol 1000 mg/L	5.30	2.89	14.8±0.1	3.3
Negative Control	4.34	2.93	10.1±0.12	3.0

**Table 5.5: The consumption rate and growth of *A. terreus* under cholesterol treatment during 9-day cultivation.** Noticeable increase in biomass and diameter could be observed when cholesterol is present in the media.

## **5.2 Other stimulating factors of *Aspergillus terreus***

### **5.2.1 Malonic acid inhibits *A. terreus* growth and metabolite production only during early stage of growth**

The pellet's weight and size were measured every 2 days to investigate the effect of malonic acid (MA) on the growth of *A. terreus* (Figure 5.7). On day 2, MA-treated media produced significantly lower biomass compared to the positive control, suggesting an inhibitory effect of MA on biomass production. Surprisingly, the growth recovered by day 4, and exceeded the control's biomass by day 6. However, the size did not improve towards the end of the cultivation, which is significantly smaller than control experiment. This observation indicates that the fungus is still growing in the presence of MA, but only increase in density rather than size.

Overall, these observations indicate that *A. terreus* may not be able to tolerate MA in the early stage of growth, but developed tolerance to MA in the later stages of growth. The addition of MA may provide additional precursor (malonyl-CoA) that is largely required for the growth of *A. terreus* [134]. The ionised form of MA, malonate, is a precursor to malonyl-CoA that is needed in many metabolic processes of living organisms, including fatty acid biosynthesis. However, MA may be highly toxic due to its function as a competitive inhibitor of the electron transport chain, an important process of the energy-producing cycle in living organisms. This observation is further supported by a decrease in biomass (compared to control) during the early stage of cultivation (day 2) and the suppression of hair growth on the fungal pellet. It is currently unknown why the diameter of the fungus never recovered.

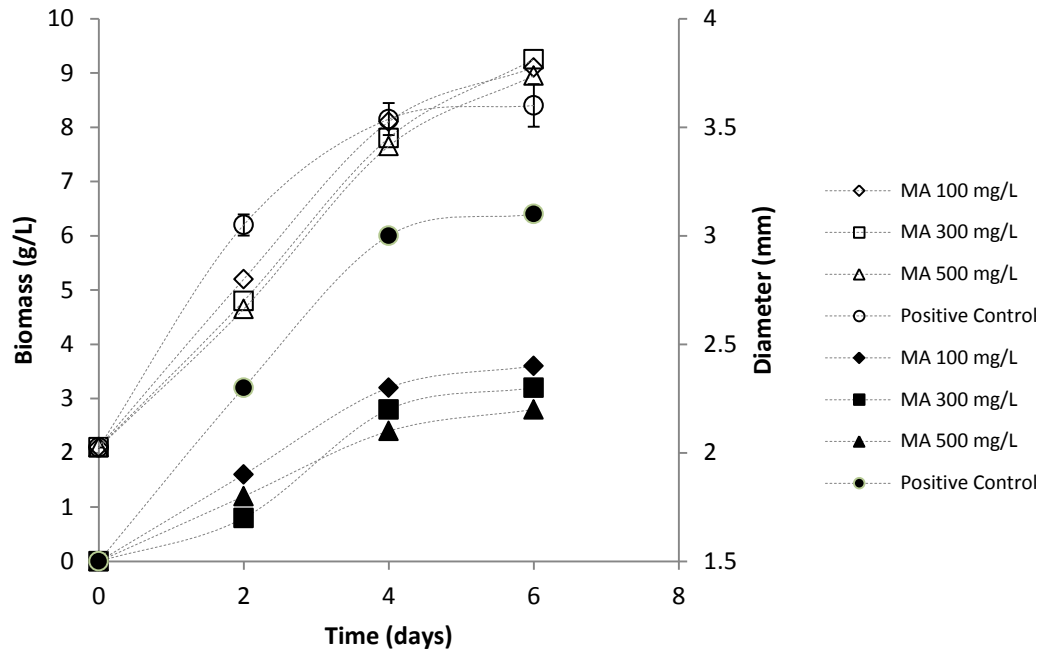

Figure 5.7: **Biomass growth and diameter of *A. terreus* over the period of 6 days.** The biomass of MA-treated fungal was suppressed during early cultivation, but recovered towards the later stage. However, the diameter never recovered. Open symbols represent the biomass production while close symbols represent the diameter of *A. terreus*.

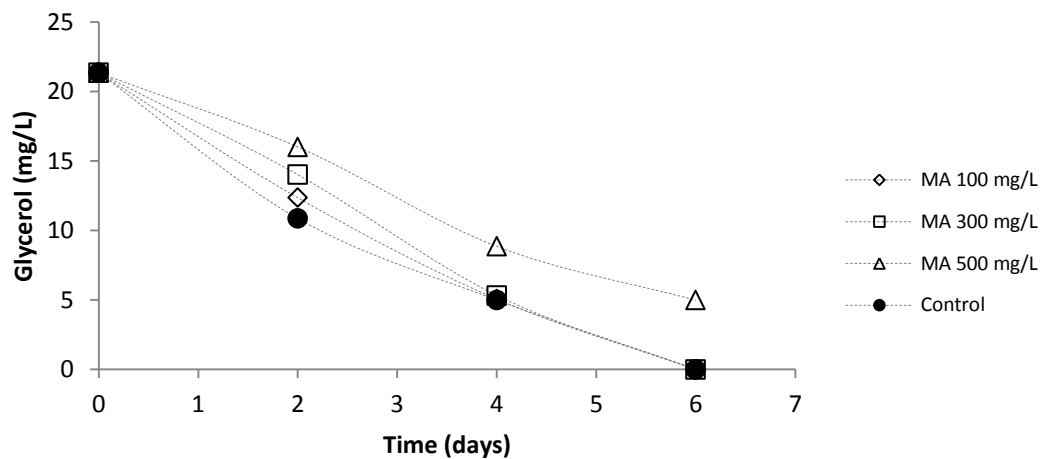

Figure 5.8: **Substrate (glycerol) consumption by *A. terreus* in shake flask.** Glycerol was consumed the fastest by the control during early cultivation.

MA also hampered substrate consumption in a concentration-dependent manner (Figure 5.8). At day 2, the glycerol consumption in 100 mg/L, 300 mg/L and 500 mg/L of MA was reduced by 13.7%, 29.0% and 47.4% respectively. However, at day 4, the consumption of glycerol in MA-treated media started to improve, except for 500 mg/L (1.1%, 6.6% and 77.2% reduction, respectively). This improvement was in line with the improved metabolite production during about the same period. By day 6, 100 mg/L and 300 mg/L of MA produced satisfactory amount of lovastatin (8.76 and 8.22 mg/L of lovastatin, respectively), closer to what was observed in the positive control at 10.53 mg/L (Figure 5.6). This is quite surprising, given that none was produced at earlier time points, and coupled with unfavourable hairless morphology. However, the highest concentration of MA (500 mg/L) seemed too toxic to produce any lovastatin. At day 9, lovastatin production at both 100 mg/L and 300 mg/L of MA significantly exceeded that of the positive control, whereas only a small amount of lovastatin was detected at 500 mg/L of MA. Collectively, this observation indicates that MA may be interfering with the normal metabolism of fungus, probably by getting involved directly in citric acid cycle, by bypassing the pyruvate and the need to use up energy in GADPH reaction, resulting in lower substrate consumption and lovastatin production at the early stage of active fungal growth. However, MA becomes stimulatory as the fungus enters the later phase (possibly stationary) as *A. terreus* became more adaptive to the presence of MA.

The production of (+)-geodin and sulochrin in 100 mg/L and 300 mg/L followed a similar pattern as lovastatin production (inhibition at early stage but stimulation at later stage), while the highest concentration of MA (500 mg/L) was still inhibitory to these metabolites (Figure 5.9). At 100 mg/L and 300 mg/L MA, none of these metabolites were detected at day 3. At day 6, the production in 100 mg/L MA improved ( $C_{\text{GEO}} = 15.76$  mg/L;  $C_{\text{SUL}} = 7.67$  mg/L), although it was still lower than positive control ( $C_{\text{GEO}} = 32.71$  mg/L;  $C_{\text{SUL}} = 19.96$  mg/L).

However, at day 9, the production in both 100 mg/L and 300 mg/L was significantly higher than positive control production. Their increase of production of (+)-geodin compared to control, in terms of percentage at 100 and 300 mg/L MA ( $MA_{GEO100} = 347\%$ ;  $MA_{GEO300} = 250\%$ ) was even higher when compared to lovastatin's percentage increase ( $MA_{LOV100} = 208\%$ ;  $MA_{LOV300} = 117\%$ ). Although the increase was also evident in sulochrin, the percentages were much lower ( $MA_{SUL100} = 179\%$ ;  $MA_{SUL300} = 24.7\%$ ). This finding is unlike previous observation where sulochrin dominated towards the end of cultivation and reduction of (+)-geodin happened as soon as day 6 (also evident in control experiment in Figure 5.9). This phenomenon is likely caused by the continual supply of precursors by MA, which shifted the equilibrium of metabolite production from sulochrin to (+)-geodin.

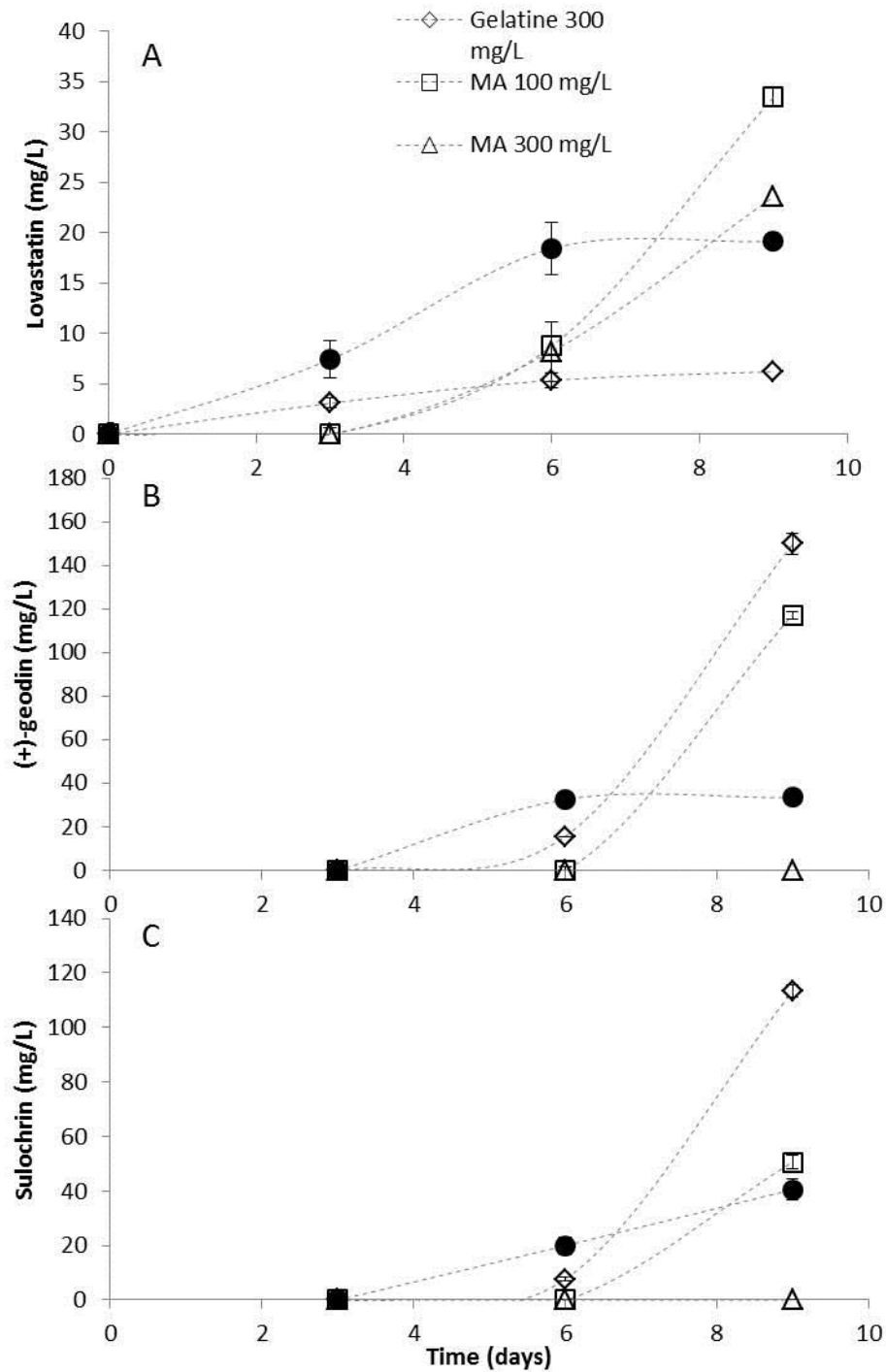

Figure 5.9: **Lovastatin, (+)- geodin and sulochrin production by *A. terreus* during the 9-days cultivation.** The open symbols represent treatments while the filled symbols represent the negative control. A) Lovastatin production, B) (+)-geodin production and C) sulochrin production.

### 5.2.2 Fungal pellet structure and integrity are related to (+)-geodin's production

This experimental model is devised to examine the role of physical elicitation or pellet integrity in stimulating the production of metabolites. To aid in breaking the pellet by friction, a linen cloth was placed at the bottom of the flask while shaking the culture continuously. The experimental method for sonication is described in the Materials and Methods section. As expected, the introduction of both the friction and sonication in the cultivation system did not return favourable morphological observation. Although biomass was slightly reduced (8.1 g/L) compared to the negative control (9.0 g/L), the size of the pellet, when friction was used, became extremely small, ranging below 0.5 mm, which was caused by the breakage of the pellet. The use of sonication produced dispersed hyphae morphology (biomass = 6.1 g/L). Dispersed morphology is defined as a morphology where no visible pellet is present, and the hyphae are freely dispersed in the medium [135].

Surprisingly, it seemed that the pellet in both conditions was still alive until the end of cultivation, as the continual production of metabolites was observed until the end of cultivation (Figure 5.10). Initially, production of lovastatin in both treatments was similar to what has been observed in the control experiment. Unexpectedly, as the fungus entered the sixth day of cultivation, lovastatin production was up by 7-fold when friction was used. In contrast, the application of sonicator on the cultivation significantly reduced lovastatin production, by 40% at day 9. It seems that there are different mechanisms in effect for lovastatin, (+)-geodin and sulochrin production in both types of cultivation, even though the integrity of the fungal pellet was disrupted. The cause of this increase in production while using friction is currently unknown, although several hypotheses can be made. Firstly, in cultivation using friction, the breakage of the pellet was not as detrimental as in that of a sonicator, and the morphology produced was still in pellet form, albeit very small. Smaller



pellet has been shown to be more efficient in producing lovastatin [43,44]. Bizukojc et al. argued that smaller *A. terreus* pellet would retain the higher active area of lovastatin production [43], although his team never studied pellets below the size of 1 mm. This hypothesis is supported by the significantly higher uptake of glycerol, as shown in Figure 5.11. Furthermore, the higher surface to volume ratio is another factor that most likely contributes to higher intake of glycerol. In sonication experiment, the breakage was very sudden and was observed within 24 hours after initial cultivation, which resulted in dispersed morphology. The dispersed morphology was known to be unfavourable to the production of lovastatin [35].

The most interesting observation was the production of (+)-geodin and sulochrin when friction was used. This time, initial observation based on physical observation already indicates that these metabolites were probably being produced in excess, as the media turned dark brown when friction was used. Further analysis showed that (+)-geodin was produced up to 12-fold while sulochrin was produced up to 5-fold when compared to the positive control at day 6. Impressively, although the increase was only 16.9% from day 6, (+)-geodin was still being produced continuously at day 9 unlike our control experiment (reduced production after day 6). Similar to what has been observed in the production of lovastatin, the production of (+)-geodin and sulochrin was very low under sonication treatment. Although slightly higher level of metabolites were still evident, their increment was not as significant as what has been observed when friction was used. The dispersed morphology created by sonication is most likely the reason the fungus could not emulate the production of (+)-geodin and sulochrin when friction was used.

As discussed before, one of the factors that stimulate the production of (+)-geodin is most likely shear stress. Due to the continual stress placed on the fungal pellet due to movement of

liquid, and friction with the cloth, it is possible that (+)-geodin's production is under constant stimulation. It is unlikely that this significant increase of metabolites occurred because the intracellular metabolites were released once the pellet was burst open. Firstly, during the initial breakage of pellet observed as early as day 2, the metabolite amount at day 3 were not as high as expected. Secondly, the metabolites were being produced consistently until the end of cultivation, even after the pellet broke into small pieces without any further observable breakage.

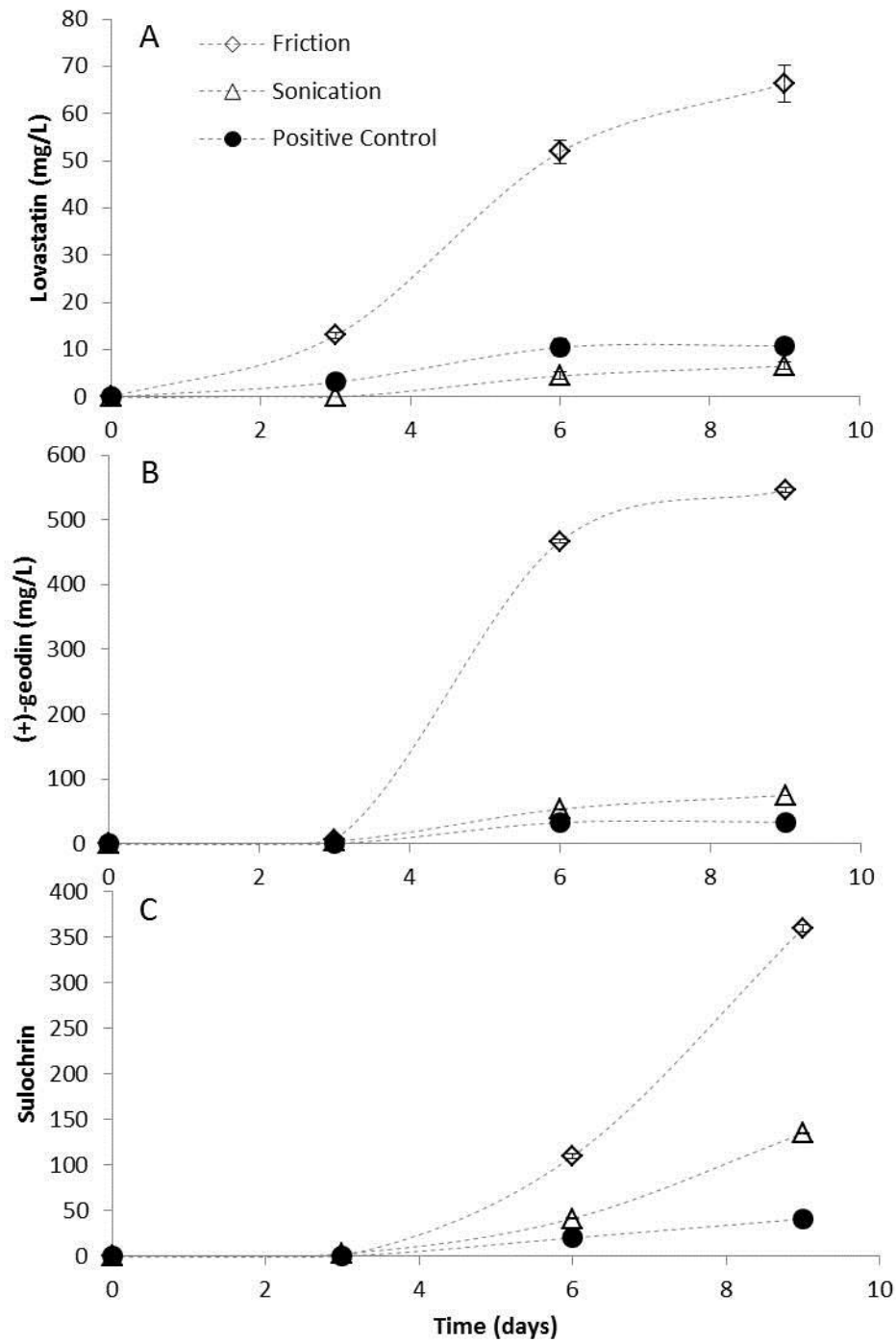

Figure 5.10: **The metabolite production profile of *A. terreus* under the effect of sonication and friction.** The disruption of pellet integrity by friction (linen cloth) affects the production of (+)-geodin and sulochrin the most, where a substantial amount of these metabolites was produced. A) Lovastatin production, B) (+)-geodin production and C) sulochrin production.

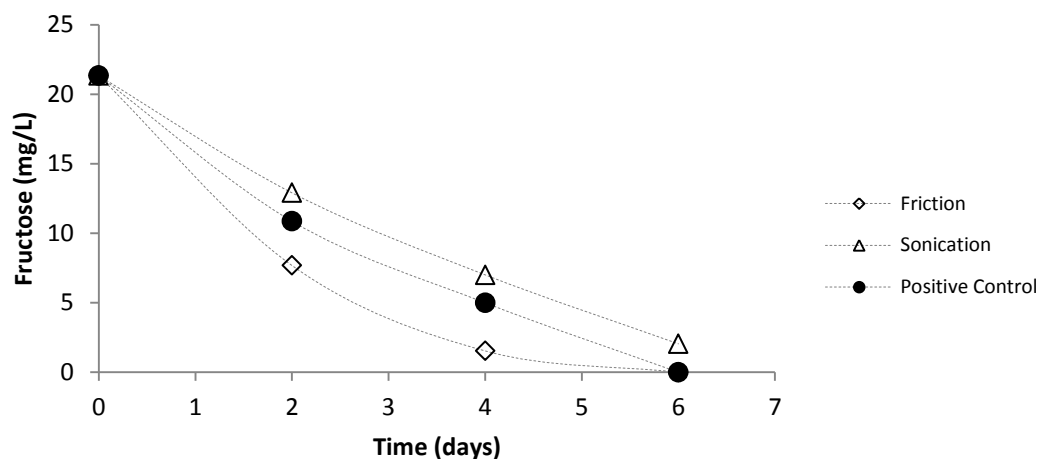

Figure 5.11: **Glycerol consumption profile of *A. terreus* under the effect of sonication and friction.** The rate of consumption was reduced in sonication, but increased when friction was used.

### 5.3 Conclusion

In this chapter, a more thorough investigation on the possible role of lovastatin, (+)-geodin and sulochrin was conducted in the form of elicitors. We found that lovastatin and sulochrin were induced strongly in the presence of SA and cholesterol. (+)-geodin (and sulochrin, to some extent) was more responsive to physical elicitors. The presence of abundant precursors may also favour more (+)-geodin, compared to lovastatin and sulochrin. This observation confirms the finding in the previous chapters, where (+)-geodin and sulochrin were implicated to be involved in the stress-related mechanism of *A. terreus*. The pattern of production also suggested that lovastatin and sulochrin is more closely related than initially thought.

## Chapter 6: Final discussion and future direction

### 6.0 Final discussion

Initial studies in this thesis characterised the production of lovastatin, (+)-geodin and sulochrin by *A. terreus* using a range of substrates/carbon sources and nitrogen sources, two major factors that influence metabolite production (discussed in Chapter 1, section 1.2.4). Of note, our findings show that better lovastatin production can be achieved using carbon sources that are abundant in nature (such as fructose and xylose). Furthermore, lovastatin production is not dependent on the rate of carbon consumption, as initially thought [49]. In contrast, (+)-geodin and sulochrin production is more dependent on the rate of carbon consumption, as slower metabolised carbon sources stimulate the production of these metabolites. The production of (+)-geodin and sulochrin is also greatly influenced by the nitrogen source, compared to lovastatin. Amongst the substrates investigated, glycerol showed a satisfactory production of lovastatin, (+)-geodin and sulochrin, and is, therefore, a suitable substrate to be used for subsequent work in this study.

Glycerol is commonly used to study the production of lovastatin by *A. terreus*, with limited information on (+)-geodin and sulochrin production. CG is an example of industrial wastes available in excess, and is, therefore, a cheaper alternative. To our knowledge, this is the first study to investigate the potential of CG as the substrate for the production of these metabolites by *A. terreus*. Fungi belonging to the *Aspergillus* genus are known to have high resistance to harsh conditions. Therefore, we hypothesised that *A. terreus* could tolerate the presence of impurities in CG. As expected, biomass growth was comparable to PG. However, lovastatin production was inhibited, while (+)-geodin and sulochrin production was stimulated. These results suggest that the contaminants present in CG inhibit the biosynthesis of lovastatin, yet they triggered the production of the two co-metabolites. Partial purification

of CG by pre-treatment with activated carbon was able to normalise the production of these metabolites (comparable to PG). Notably, our findings highlight that the presence of single or double-bonded fatty acids in CG may have differential effects on metabolite production. Pre-treatment with petroleum ether, which is known to remove mainly saturated fatty acids [118], augmented lovastatin production and normalised (+)-geodin and sulochrin production. Consistent with this finding, treatment with oleic acid (unsaturated) in culture using PG as the substrate increased the production of these three metabolites, whereas treatment with PA (saturated) inhibited their production. These results suggest that contaminants other than fatty acids may be responsible for the augmented production of (+)-geodin and sulochrin in CG.

Given that purification of CG by pre-treatment with activated carbon showed that lovastatin, (+)-geodin and sulochrin production was comparable to that of PG, this was used as the substrate in subsequent investigations. The effects of several factors including ‘elicitors’ and malonic acid (MA), on the production of the three metabolites, were studied. Elicitors are compounds that can provoke the defense mechanism of microorganisms, which in turn activates the production of secondary metabolites. Our findings revealed that chemical elicitors may provoke the production of lovastatin and sulochrin, but not (+)-geodin; suggesting that lovastatin and sulochrin may have a protective role in *A. terreus*. The production of all three metabolites was also increased in response to a high shear force (physical elicitor), however (+)-geodin’s production, in particular, was increased up to 12-fold. This suggests that (+)-geodin may play an important role in the regulation of pellet integrity or response to physical injury. The use of cholesterol under the assumption it may act as a chemical elicitor were likely to be unsuccessful, due to the pattern difference compared to the previous investigations. This pattern may be attributed to positive effects of cholesterol on growth, as indicated by increased biomass and optimal hair growth.

In conclusion, there is a large potential for the use of bio-waste substrates such as CG in *A. terreus* cultivation and metabolite production, provided that the substrate is subjected to appropriate purification. This work also provides new insights into the production pattern of lovastatin, (+)-geodin and sulochrin by *A. terreus*. Lovastatin and sulochrin were shown to be more closely related to each other, while (+)-geodin was produced more situationally.

## 6.1 Future direction

This thesis has demonstrated a promising potential for CG to be used as the substrate for *A. terreus* cultivation and metabolite production under specific conditions. Future directions for this work include:

- (1) Further investigation into the methods of purification to enhance the quality of CG. As shown in Chapter 4, subsection 4.4.1, pre-treatments with specific solvents can improve the production of metabolites. Specifically, new methods of purification could be identified and optimised, along with an analysis of the quality and content of purified CG after the pre-treatments. For example, the use of several established methods in wastewater treatments, such as brine treatment, oil and grease removal, removal of organics and biodegradable organic, activated sludge process, trickling filter process, treatment of acids, alkalis and toxic materials can be performed on CG to improve its quality for fungal cultivation.
- (2) Further investigation into the effect of specific fatty acids on the production of metabolites by *A. terreus*. Specifically, the type of fatty acids and their content in raw and purified CG could be analysed by performing Gas Chromatography-Mass Spectrometry (GCMS), as described previously [116], [68] and [94]. Subsequent studies could be performed to study the effects of identified fatty acids on the production of metabolites in *A. terreus* culture.
- (3) Further investigation into the role of sulochrin and (+)-geodin in *A. terreus*, and identification of other main co-metabolites that may be related to lovastatin biosynthesis pathway. The HPLC analysis in appendices showed the presence of an additional compound, together with the three metabolites studied. It may be interesting to identify this compound and assess its significance. This can be performed by comparing the known standards of



HPLC with the unknown peak. Subsequently, the identity of the compound can be confirmed using GCMS.

(4) Detailed assessment and characterisation of morphological changes of fungal pellets, and their influence on metabolites production. Features such as the size and presence of hair were examined in most of this study. Other features such as hair length [35] could be measured, and the active sites on the fungal pellet [43] could be determined. These studies would increase our understanding of the relationship between specific metabolites and the morphological features of *A. terreus*, and their significance.

(5) Characterisation of the expression of genes important for the biosynthesis of lovastatin and its co-metabolites in *A. terreus*, other than the *lovB* gene (discussed in Chapter 1 and Chapter 3). These studies would increase our understanding of their synthetic pathways and may lead to better strategies to improve the production of the metabolite(s) of interest.

(6) To genetically-engineered *A. terreus* strain to optimize the metabolite production. Specifically, the overexpression of several pathways, such as precursor's production pathway (Malonyl-CoA, Acetyl-CoA) may increase the production of metabolites. Similarly, the under expression of certain pathways, such as the reduction of the fatty acid biosynthetic pathway, may cause more carbon flux towards the metabolite production. The improvement can also be made in other departments, such as in the area of survivability or the ability to take up the foreign substrate. For example, *A. terreus* can be made more resistant to the inhibitory compound found in CG, and can take up the CG more efficiently.

(7) Characterisation of the nitrogen consumption to clarify the link between the types of nitrogen source, the rate of consumption and metabolite production (refer to Chapter 3, subsection 3.2). In this work, only carbon consumption was quantified due to the lack of necessary equipment. The analysis of nitrogen would provide a better understanding of the

production of (+)-geodin and sulochrin as it was shown that these metabolites are more dependent on nitrogen source.

(8) The investigation into the effects of sonication using low frequency or pulse sonication on metabolites production. Given that these methods are less likely to cause dispersed morphology (refer to chapter 5, subsection 5.5.2), compared to the continuous sonication, the production metabolites is likely to improve as a result of increased release of intracellular products, as described previously [47].

(9) An extended study into the potential of other industrial wastes composed of better carbon sources than glycerol for *A. terreus* cultivation. Our initial screening of a range of carbon source revealed that fructose and xylose are more optimal for *A. terreus* cultivation and metabolite production. It is, therefore, worthwhile to investigate whether bio-waste products such as whey and waste beet pulp may be more beneficial for *A. terreus* cultivation and could improve the production of metabolite of interest such as lovastatin.

## References

- [1] C. Lass-Flörl, *Aspergillus terreus*: How Inoculum Size and Host Characteristics Affect Its Virulence, *J. Infect. Dis.* . 205 (2012) 1192–1194.
- [2] A. Demain, A. Fang, The Natural Functions of Secondary Metabolites, in: A. Fiechter (Ed.), *Hist. Mod. Biotechnol. I SE - 1*, Springer Berlin Heidelberg, 2000: pp. 1–39.
- [3] R.N. Bennett, R.M. Wallsgrove, Secondary metabolites in plant defence mechanisms, *New Phytol.* 127 (1994) 617–633.
- [4] J. Dighton, J. White, P. Oudemans, *The Fungal Community: Its Organization and Role in the Ecosystem*, Second Edition, CRC Press, 1992.
- [5] J. (Hans) van Leeuwen, M. Rasmussen, S. Sankaran, C. Koza, D. Erickson, D. Mitra, et al., Fungal Treatment of Crop Processing Wastewaters with Value-Added Co-Products, in: K. Gopalakrishnan, J. (Hans) van Leeuwen, R.C. Brown (Eds.), *Sustain. Bioenergy Bioprod. SE - 2*, Springer London, 2012: pp. 13–44.
- [6] J. Barrios-González, R. Miranda, Biotechnological production and applications of statins, *Appl. Microbiol. Biotechnol.* 85 (2010) 869–883. doi:10.1007/s00253-009-2239-6.
- [7] G. Martin, H. Duez, C. Blanquart, V. Berezowski, P. Poulain, J.-C. Fruchart, et al., Statin-induced inhibition of the Rho-signaling pathway activates PPAR $\alpha$  and induces HDL apoA-I, *J. Clin. Invest.* 107 (2001) 1423–1432.
- [8] J.K. Liao, U. Laufs, Pleiotropic Effects Of Statins, *Annu. Rev. Pharmacol. Toxicol.* 45 (2004) 89–118.

- [9] M.J. Gonyeau, Statins and osteoporosis: a clinical review, *Pharmacotherapy*. 25 (2005) 228–43.
- [10] A.C.R.G. Fonseca, R. Resende, C.R. Oliveira, C.M.F. Pereira, Cholesterol and statins in Alzheimer's disease: Current controversies, *Exp. Neurol.* 223 (2010) 282–293.
- [11] A. Martirosyan, J. Clendening, C. Goard, L. Penn, Lovastatin induces apoptosis of ovarian cancer cells and synergizes with doxorubicin: potential therapeutic relevance, *BMC Cancer*. 10 (2010) 103. <http://www.biomedcentral.com/1471-2407/10/103>.
- [12] K. Hindler, C.S. Cleeland, E. Rivera, C.D. Collard, The role of statins in cancer therapy., *Oncologist*. 11 (2006) 306–15.
- [13] A. Endo, The origin of the statins. 2004., *Atheroscler. Suppl.* 5 (2004) 125–30.
- [14] M. Manzoni, M. Rollini, Biosynthesis and biotechnological production of statins by filamentous fungi and application of these cholesterol-lowering drugs, *Appl Microbiol Biotechnol.* 58 (2002) 555–564.
- [15] A. Endo, M. Kuroda, Y. Tsujita, MI-236a, MI-236b, And MI-236c, New Inhibitors Of Cholesterologenesis Produced By *Penicillium Citrinum*, *J. Antibiot. (Tokyo)*. 29 (1976) 1346–1348.
- [16] J.A. Tobert, Lovastatin and beyond: the history of the HMG-CoA reductase inhibitors, *Nat Rev Drug Discov.* 2 (2003) 517–526.
- [17] Scandinavian Simvastatin Survival Study Group, Randomised trial of cholesterol lowering in 4444 patients with coronary heart disease: the Scandinavian Simvastatin Survival Study (4S), *Lancet*. 344 (1994) 1383–1389.
- [18] Pfizer, ed., *Doing Things Differently*, 2008.

- [19] A. Berenson, Merck Loses Protection for Patent on Zocor, *New York Times*. (2006).
- [20] A. Endo, K. Hasumi, S. Negishi, Monacolins J and L, new inhibitors of cholesterol biosynthesis produced by *Monascus ruber*, *J Antibiot.* 38 (1985) 420–422.
- [21] L. Debakey, A. Endo, A gift from nature: the birth of the statins, *Nat. Med.* 14 (2008) 1050–2.
- [22] M. Askenazi, E.M. Driggers, D.A. Holtzman, T.C. Norman, S. Iverson, D.P. Zimmer, et al., Integrating transcriptional and metabolite profiles to direct the engineering of lovastatin-producing fungal strains., *Nat. Biotechnol.* 21 (2003) 150–6.
- [23] R.S. Gokhale, D. Tuteja, *Biochemistry of Polyketide Synthases*, in: *Biotechnology*, Wiley-VCH Verlag GmbH, 2008: pp. 341–372.
- [24] J. Staunton, K.J. Weissman, Polyketide biosynthesis: a millennium review, *Nat. Prod. Rep.* 18 (2001) 380–416.
- [25] U. Rix, C. Fischer, L.L. Remsing, J. Rohr, Modification of post-PKS tailoring steps through combinatorial biosynthesis, *Nat. Prod. Rep.* 19 (2002) 542–580.
- [26] J. Kennedy, K. Auclair, S.G. Kendrew, C. Park, J.C. Vederas, C. Richard Hutchinson, Modulation of Polyketide Synthase Activity by Accessory Proteins During Lovastatin Biosynthesis, *Science* (80-. ). 284 (1999) 1368–1372.
- [27] A. Sutherland, K. Auclair, J.C. Vederas, Recent Advances In The Biosynthetic Studies Of Lovastatin, *Curr. Opin. Drug Discov. Dev.* 4 (2001) 229–236.
- [28] B.D. Ames, C. Nguyen, J. Bruegger, P. Smith, W. Xu, S. Ma, et al., Crystal structure and biochemical studies of the trans-acting polyketide enoyl reductase LovC from lovastatin biosynthesis, *Proc. Natl. Acad. Sci.* . 109 (2012) 11144–11149.

- [29] J.L. Casas López, J.A. Sánchez Pérez, J.M. Fernández Sevilla, F.G. Ación Fernández, E. Molina Grima, Y. Chisti, Fermentation optimization for the production of lovastatin by *Aspergillus terreus*: use of response surface methodology, *J. Chem. Technol. Biotechnol.* 79 (2004) 1119–1126.
- [30] L.-S.T. Lai, T.-H. Tsai, T.C. Wang, Application of oxygen vectors to *Aspergillus terreus* cultivation, *J. Biosci. Bioeng.* 94 (2002) 453–459.
- [31] N. Novak, S. Gerdin, M. Berovic, Increased lovastatin formation by *Aspergillus terreus* using repeated fed-batch process, *Biotechnol. Lett.* 19 (1997) 947–948.
- [32] E.M. Rodríguez Porcel, J.L. Casas López, J.A. Sánchez Pérez, J.M. Fernández Sevilla, J.L. García Sánchez, Y. Chisti, *Aspergillus terreus* Broth Rheology, Oxygen Transfer, and Lovastatin Production in a Gas-Agitated Slurry Reactor, *Ind. Eng. Chem. Res.* 45 (2006) 4837–4843.
- [33] E.M. Rodríguez Porcel, J.L. Casas López, J.A. Sánchez Pérez, J.M. Fernández Sevilla, Y. Chisti, Effects of pellet morphology on broth rheology in fermentations of *Aspergillus terreus*, *Biochem. Eng. J.* 26 (2005) 139–144.
- [34] J.L. Casas López, J.A. Sánchez Pérez, J.M. Fernández Sevilla, E.M. Rodríguez Porcel, Y. Chisti, Pellet morphology, culture rheology and lovastatin production in cultures of *Aspergillus terreus*, *J. Biotechnol.* 116 (2005) 61–77.
- [35] M. Bizukojc, S. Ledakowicz, Physiological, morphological and kinetic aspects of lovastatin biosynthesis by *Aspergillus terreus*, *Biotechnol. J.* 4 (2009) 647–664.
- [36] M. Bizukojc, S. Ledakowicz, Biosynthesis of lovastatin and (+)-geodin by *Aspergillus terreus* in batch and fed-batch culture in the stirred tank bioreactor, *Biochem. Eng. J.* 42 (2008) 198–207.

- [37] H. Hajjaj, P. Niederberger, P. Duboc, Lovastatin Biosynthesis by *Aspergillus terreus* in a Chemically Defined Medium, *Appl. Environ. Microbiol.* 67 (2001) 2596–2602.
- [38] L.-S.T. Lai, C.-S. Hung, C.-C. Lo, Effects of lactose and glucose on production of itaconic acid and lovastatin by *Aspergillus terreus* ATCC 20542, *J. Biosci. Bioeng.* 104 (2007) 9–13.
- [39] L.-S.T. Lai, C.M. Kuo, S.Y. Tsai, Influence of increased dissolved oxygen tensions by agitation on secondary metabolite production by a mutant of *Aspergillus terreus* in a 5L fermentor, *J. Chin. Inst. Chem Engrs.* 32 (2003) 135–142.
- [40] L.-S.T. Lai, T.-H. Tsai, T.C. Wang, T.-Y. Cheng, The influence of culturing environments on lovastatin production by *Aspergillus terreus* in submerged cultures, *Enzyme Microb. Technol.* 36 (2005) 737–748.
- [41] L.-S.T. Lai, C.-C. Pan, B.-K. Tzeng, The influence of medium design on lovastatin production and pellet formation with a high-producing mutant of *Aspergillus terreus* in submerged cultures, *Process Biochem.* 38 (2003) 1317–1326.
- [42] B. Metz, N.W.F. Kossen, The growth of molds in the form of pellets—a literature review, *Biotechnol. Bioeng.* 19 (1977) 781–799.
- [43] M. Bizukoje, S. Ledakowicz, The morphological and physiological evolution of *Aspergillus terreus* mycelium in the submerged culture and its relation to the formation of secondary metabolites, *World J. Microbiol. Biotechnol.* 26 (2010) 41–54.
- [44] K. Gupta, P.K. Mishra, P. Srivastava, A correlative evaluation of morphology and rheology of *Aspergillus terreus* during lovastatin fermentation, *Biotechnol. Bioprocess Eng.* 12 (2007) 140–146.

- [45] H. Sainz, N. N, L. Casas, J. Pez, P. Nchez, J. Rez, et al., Effects of ultrasound on culture of *Aspergillus terreus*, *J. Chem. Technol. Biotechnol.* 83 (2008) 593–600.
- [46] B. Naveena, P. Sakthiselvan, P. Elaiyaraju, N. Partha, Ultrasound induced production of thrombinase by marine actinomycetes: Kinetic and optimization studies, *Biochem. Eng. J.* 61 (2012) 34–42.
- [47] Y. Chisti, Sonobioreactors: using ultrasound for enhanced microbial productivity, *Trends Biotechnol.* 21 (2003) 89–93.
- [48] B.E. Wood, H.C. Aldrich, L.O. Ingram, Ultrasound Stimulates Ethanol Production during the Simultaneous Saccharification and Fermentation of Mixed Waste Office Paper, *Biotechnol. Prog.* 13 (1997) 232–237.
- [49] J.. L. Casas López, J.. A. Sánchez Pérez, J.. M. Fernández Sevilla, F.. G. Ación Fernández, E. Molina Grima, Y. Chisti, et al., Production of lovastatin by *Aspergillus terreus*: effects of the C:N ratio and the principal nutrients on growth and metabolite production, *Enzyme Microb. Technol.* 33 (2003) 270–277.
- [50] G. Szakács, G. Morovján, R. Tengerdy, Production of lovastatin by a wild strain of *Aspergillus terreus*, *Biotechnol. Lett.* 20 (1998) 411–415.
- [51] M.S. Kumar, S.K. Jana, V. Senthil, V. Shashanka, S.V. Kumar, A.. K. Sadhukhan, Repeated fed-batch process for improving lovastatin production, *Process Biochem.* 36 (2000) 363–368.
- [52] Marcin Bizukojc, S. Ledakowicz, Influence of environmental factors on mycelial growth and biosynthesis of lovastatin by *Aspergillus terreus*, *Biotechnologia-Monografie.* 2 (2005) 25–36.



- [53] M. Bizukojc, S. Ledakowicz, A macrokinetic modelling of the biosynthesis of lovastatin by *Aspergillus terreus*, *J. Biotechnol.* 130 (2007) 422–435.
- [54] M. Pecyna, M. Bizukojc, Lovastatin biosynthesis by *Aspergillus terreus* with the simultaneous use of lactose and glycerol in a discontinuous fed-batch culture, *J. Biotechnol.* 151 (2011) 77–86.
- [55] Z. Jia, X. Zhang, Y. Zhao, X. Cao, Effects of divalent metal cations on lovastatin biosynthesis from *Aspergillus terreus* in chemically defined medium, *World J. Microbiol. Biotechnol.* 25 (2009) 1235–1241.
- [56] M. Bizukojc, B. Pawlowska, S. Ledakowicz, Supplementation of the cultivation media with B-group vitamins enhances lovastatin biosynthesis by *Aspergillus terreus*, *J. Biotechnol.* 127 (2007) 258–268.
- [57] T.G. Schimmel, A.D. Coffman, S.J. Parsons, Effect of Butyrolactone I on the Producing Fungus, *Aspergillus terreus*, *Appl. Environ. Microbiol.* 64 (1998) 3707–3712. <http://aem.asm.org/cgi/content/abstract/64/10/3707>.
- [58] J. Hargreaves, J. Park, E.L. Ghisalberti, K. Sivasithamparam, B.W. Skelton, A.H. White, New Chlorinated Diphenyl Ethers from an *Aspergillus* Species, *J. Nat. Prod.* 65 (2001) 7–10.
- [59] V.A. Vinci, T.D. Hoerner, A.D. Coffman, T.G. Schimmel, R.L. Dabora, A.C. Kirpekar, et al., Mutants of a lovastatin-hyperproducing *Aspergillus terreus* deficient in the production of sulochrin, *J. Ind. Microbiol.* 8 (1991) 113–119.
- [60] M. Bizukojc, S. Ledakowicz, Simultaneous biosynthesis of (+)-geodin by a lovastatin-producing fungus *Aspergillus terreus*, *J. Biotechnol.* 132 (2007) 453–60.

- [61] C. Shinohara, T. Chikanishi, S. Nakashima, A. Hashimoto, A. Hamanaka, A. Endo, et al., Enhancement of fibrinolytic activity of vascular endothelial cells by chaetoglobosin A, crinipellin B, geodin and triticone B., *J. Antibiot. (Tokyo)*. 53 (2000) 262–8.
- [62] S. Bräse, A. Encinas, J. Keck, C.F. Nising, S. Bräse, *Chemistry and Biology of Mycotoxins and Related Fungal Metabolites*, *Chem. Rev.* 109 (2009) 3903–3990.
- [63] H.J. Lee, J.H. Lee, B.Y. Hwang, H.S. Kim, J.J. Lee, Fungal metabolites, asterriac acid derivatives inhibit vascular endothelial growth factor (VEGF)-induced tube formation of HUVECs., *J. Antibiot. (Tokyo)*. 55 (2002) 552–6.
- [64] R.D. Couch, G.M. Gaucher, Rational elimination of *Aspergillus terreus* sulochrin production, *J. Biotechnol.* 108 (2004) 171–177.
- [65] M. Okabe, D. Lies, S. Kanamasa, E. Park, Biotechnological production of itaconic acid and its biosynthesis in *Aspergillus terreus*, *Appl. Microbiol. Biotechnol.* 84 (2009) 597–606.
- [66] P. Bonnarme, B. Gillet, A.M. Sepulchre, C. Role, J.C. Beloeil, C. Ducrocq, Itaconate biosynthesis in *Aspergillus terreus*, *J. Bacteriol.* 177 (1995) 3573–8.
- [67] Y.-Y. Zhan, Y. Zhang, Q.-M. Li, X.-Z. Du, A Novel Visible Spectrophotometric Method for the Determination of Methanol Using Sodium Nitroprusside as Spectroscopic Probe, *J. Chinese Chem. Soc.* 57 (2010) 230–235.
- [68] S.K. Athalye, R. a Garcia, Z. Wen, Use of biodiesel-derived crude glycerol for producing eicosapentaenoic acid (EPA) by the fungus *Pythium irregulare*, *J Agric Food Chem.* 57 (2009) 2739–2744.

- [69] D.-J. Yang, L.S. Hwang, Study on the conversion of three natural statins from lactone forms to their corresponding hydroxy acid forms and their determination in Pu-Erh tea., *J. Chromatogr. A.* 1119 (2006) 277–84.
- [70] T. Masuko, A. Minami, N. Iwasaki, T. Majima, S.-I. Nishimura, Y.C. Lee, Carbohydrate analysis by a phenol-sulfuric acid method in microplate format, *Anal. Biochem.* 339 (2005) 69–72.
- [71] T. Wucherpfennig, T. Hestler, R. Krull, Morphology engineering - Osmolality and its effect on *Aspergillus niger* morphology and productivity, *Microb. Cell Fact.* 10 (2011) 10–58.
- [72] A. Chatzifragkou, A. Makri, A. Belka, S. Bellou, M. Mavrou, M. Mastoridou, et al., Biotechnological conversions of biodiesel derived waste glycerol by yeast and fungal species, *Energy.* 36 (2011) 1097–1108.
- [73] A. Chatzifragkou, D. Dietz, M. Komaitis, A.-P. Zeng, S. Papanikolaou, Effect of biodiesel-derived waste glycerol impurities on biomass and 1,3-propanediol production of *Clostridium butyricum* VPI 1718., *Biotechnol. Bioeng.* 107 (2010) 76–84.
- [74] M. Bizukojc, M. Pecyna, Lovastatin and (+)-geodin formation by *Aspergillus terreus* ATCC 20542 in a batch culture with the simultaneous use of lactose and glycerol as carbon sources, *Eng. Life Sci.* 11 (2011) 272–282.
- [75] E.R. Porcel, J.L.C. López, M. a V. Ferrón, J. a S. Pérez, J.L.G. Sánchez, Y. Chisti, Effects of the sporulation conditions on the lovastatin production by *Aspergillus terreus*, *Bioprocess Biosyst. Eng.* 29 (2006) 1–5.

- [76] W.H. Peterson, E.B. Fred, J.A. Anderson, THE Fermentation of hexoses and related compounds by certain pentose fermenting bacteria, *J. Biol. Chem.* 53 (1922) 111–123.
- [77] S. Fernandes, P. Murray, Metabolic engineering for improved microbial pentose fermentation, *Bioeng. Bugs.* 1 (n.d.) 424–8.
- [78] S. Klaubauf, C. Ribot, D. Melayah, A. Lagorce, M.-H. Lebrun, R.P. de Vries, The pentose catabolic pathway of the rice-blast fungus *Magnaporthe oryzae* involves a novel pentose reductase restricted to few fungal species, *FEBS Lett.* 587 (2013) 1346–1352.
- [79] M. Bettiga, O. Bengtsson, B. Hahn-Hägerdal, M. Gorwa-Grauslund, Arabinose and xylose fermentation by recombinant *Saccharomyces cerevisiae* expressing a fungal pentose utilization pathway, *Microb. Cell Fact.* 8 (2009) 1–12.
- [80] U. Christensen, B.S. Gruben, S. Madrid, H. Mulder, I. Nikolaev, R.P. de Vries, Unique regulatory mechanism for D-galactose utilization in *Aspergillus nidulans*, *Appl. Environ. Microbiol.* 77 (2011) 7084–7.
- [81] Z. Jia, X. Zhang, X. Cao, Effects of carbon sources on fungal morphology and lovastatin biosynthesis by submerged cultivation of *Aspergillus terreus*, *Asia-Pacific J. Chem. Eng.* 4 (2009) 672–677.
- [82] C.F.B. Witteveen, R. Busink, P. Van De Vondervoort, C. Dijkema, K. Swart, J. Visser, L-Arabinose and D-Xylose Catabolism in *Aspergillus niger*, *Microbiology.* 135 (1989) 2163–2171.
- [83] B. Seiboth, B. Metz, Fungal arabinan and l-arabinose metabolism, *Appl. Microbiol. Biotechnol.* 89 (2011) 1665–1673.

- [84] P.A. Vankuyk, J.A. Diderich, A.P. MacCabe, O. Hererro, G.J.G. Ruijter, J. Visser, *Aspergillus niger* mstA encodes a high-affinity sugar/H<sup>+</sup> symporter which is regulated in response to extracellular pH., *Biochem. J.* 379 (2004) 375–83.
- [85] X. Lu, J. Sun, M. Nimtz, J. Wissing, A.-P. Zeng, U. Rinas, The intra- and extracellular proteome of *Aspergillus niger* growing on defined medium with xylose or maltose as carbon substrate., *Microb. Cell Fact.* 9 (2010) 23.
- [86] F. Sorrentino, I. Roy, T. Keshavarz, Impact of linoleic acid supplementation on lovastatin production in *Aspergillus terreus* cultures, *Appl. Microbiol. Biotechnol.* 88 (2010) 65–73.
- [87] M. McCoy, Glycerin Surplus, *Chem. Eng. News.* 83 (2006) 24–26.
- [88] A.B.G. Inc., *Glycerin Market Analysis*, Indianapolis, 2008.
- [89] D.T. Johnson, K.A. Taconi, The glycerin glut: Options for the value-added conversion of crude glycerol resulting from biodiesel production, *Environ. Prog.* 26 (2007) 338–348. doi:10.1002/ep.10225.
- [90] C.F. Hansen, A. Hernandez, B.P. Mullan, K. Moore, M. Trezona-Murray, R.H. King, et al., A chemical analysis of samples of crude glycerol from the production of biodiesel in Australia, and the effects of feeding crude glycerol to growing-finishing pigs on performance, plasma metabolites and meat quality at slaughter., *Anim. Prod. Sci.* 49 (2009) 154–161.
- [91] F. Barbirato, D. Chedaille, A. Bories, Propionic acid fermentation from glycerol: comparison with conventional substrates, *Appl. Microbiol. Biotechnol.* 47 (1997) 441–446.

- [92] D.J. Pyle, Use of Biodiesel-Derived Crude Glycerol for the Production of Omega-3 Polyunsaturated Fatty Acids by the Microalga *Schizochytrium limacinum* Use of Biodiesel-Derived Crude Glycerol for the Production of Omega-3 Polyunsaturated Fatty Acids by the Microalga , (2008).
- [93] Z. Chi, D. Pyle, Z. Wen, C. Frear, S. Chen, A laboratory study of producing docosahexaenoic acid from biodiesel-waste glycerol by microalgal fermentation, *Process Biochem.* 42 (2007) 1537–1545.
- [94] A. André, A. Chatzifragkou, P. Diamantopoulou, D. Sarris, A. Philippoussis, M. Galiotou-Panayotou, et al., Biotechnological conversions of bio-diesel-derived crude glycerol by *Yarrowia lipolytica* strains, *Eng. Life Sci.* 9 (2009) 468–478.
- [95] A. Maller, A.R.L. Damásio, T.M. da Silva, J.A. Jorge, H.F. Terenzi, M.D.L.T.D.M. Polizeli, Biotechnological Potential of Agro-Industrial Wastes as a Carbon Source to Thermostable Polygalacturonase Production in *Aspergillus niveus*., *Enzyme Res.* 2011 (2011) 289206.
- [96] G.S. Dhillon, S.K. Brar, S. Kaur, M. Verma, Screening of agro-industrial wastes for citric acid bioproduction by *Aspergillus niger* NRRL 2001 through solid state fermentation., *J. Sci. Food Agric.* 93 (2013) 1560–7.
- [97] B.T.M. Ingram LO, Effect of alcohol on microorganisms, 1984.
- [98] I.S. Maddox, M. Hossain, J.D. Brooks, The effect of methanol on citric acid production from galactose by *Aspergillus niger*, *Appl. Microbiol. Biotechnol.* 23 (1986) 203–205.
- [99] H. Asthana, A.E. Humphery, V. Moritz, Growth of yeast on methanol as the sole carbon substrate, *Biotechnol. Bioeng.* 13 (1971) 923–929.

- [100] H. Sahn, Metabolism of methanol by yeasts, in: T. Ghose, A. Fiechter, N. Blakebrough (Eds.), *Adv. Biochem. Eng. Vol. 6*, Springer Berlin / Heidelberg, 1977: pp. 77–103.
- [101] B. Snedecor, C.L. Cooney, Thermophilic Mixed Culture of Bacteria Utilizing Methanol for Growth, *Appl. Microbiol.* 27 (1974) 1112–1117.
- [102] A.B. Zepeda, C.A. Figueroa, D.S.P. Abdalla, A.Q. Maranhão, P.H. Ulloa, A. Pessoa, et al., Biomarkers to evaluate the effects of temperature and methanol on recombinant *Pichia pastoris*, *Brazilian J. Microbiol.* 45 (2014) 475–483.
- [103] I.-U. Haq, S. Ali, M.A. Qadeer, J. Iqbal, Stimulatory effect of alcohols (methanol and ethanol) on citric acid productivity by a 2-deoxy D-glucose resistant culture of *Aspergillus niger* GCB-47, *Bioresour. Technol.* 86 (2003) 227–233.
- [104] A.E. Allaway, D.H. Jennings, The Influence Of Cations On Glucose Transport And Metabolism By, And The Loss Of Sugar Alcohols From, The Fungus *Dendryphiella Salina*, *New Phytol.* 69 (1970) 581–593.
- [105] T. Bobowicz-Lassociska, W. Grajek, Changes in protein secretion of *Aspergillus niger* caused by the reduction of the water activity by potassium chloride, *Acta Biotechnol.* 15 (1995) 277–287.
- [106] J. Fiedurek, Effect of osmotic stress on glucose oxidase production and secretion by *Aspergillus niger*, *J. Basic Microbiol.* 38 (1998) 107–112.
- [107] R.E. Marquis, Salt-induced contraction of bacterial cell walls., *J. Bacteriol.* 95 (1968) 775–81.

- [108] E.A.E. Elsheikh, M. Wood, Response of chickpea and soybean rhizobia to salt: Osmotic and specific ion effects of salts, *Soil Biol. Biochem.* 21 (1989) 889–895.
- [109] A.A. Al Musallam, S.S. Radwan, Wool-colonizing micro-organisms capable of utilizing wool-lipids and fatty acids as sole sources of carbon and energy, *J. Appl. Bacteriol.* 69 (1990) 806–813.
- [110] J.L. Van Etten, D. Gottlieb, Biochemical Changes During the Growth of Fungi II. Ergosterol and Fatty Acids in *Penicillium atrovenetum*, *J. Bacteriol.* 89 (1965) 409–414.
- [111] A.M. Calvo, L.L. Hinze, H.W. Gardner, N.P. Keller, Sporogenic Effect of Polyunsaturated Fatty Acids on Development of *Aspergillus* spp, *Appl. Environ. Microbiol.* 65 (1999) 3668–3673.
- [112] Y. Fukushima, H. Itoh, T. Fukase, H. Motai, Stimulation of protease production by *Aspergillus oryzae* with oils in continuous culture, *Appl. Microbiol. Biotechnol.* 34 (1991) 586–590.
- [113] S.J. Stasinopoulos, R.J. Seviour, Stimulation of exopolysaccharide production in the fungus *Acremonium persicinum* with fatty acids, *Biotechnol. Bioeng.* 36 (1990) 778–782.
- [114] R.A. Wilson, P.-K. Chang, A. Dobrzyn, J.M. Ntambi, R. Zarnowski, N.P. Keller, Two  $\Delta^9$ -stearic acid desaturases are required for *Aspergillus nidulans* growth and development, *Fungal Genet. Biol.* 41 (2004) 501–509.
- [115] C. Altieri, D. Cardillo, A. Bevilacqua, M. Sinigaglia, Inhibition of *Aspergillus* spp. and *Penicillium* spp. by Fatty Acids and Their Monoglycerides, *J. Food Prot.* 70 (2007) 1206–1212.



- [116] D.J. Pyle, R.A. Garcia, Z. Wen, Producing docosahexaenoic acid (DHA)-rich algae from biodiesel-derived crude glycerol: effects of impurities on DHA production and algal biomass composition., *J. Agric. Food Chem.* 56 (2008) 3933–9.
- [117] R. Ukeles, Inhibition Of Unicellular Algae By Synthetic Surface-Active Agents, *J. Phycol.* 1 (1965) 102–110.
- [118] P. Anand, R.K. Saxena, A comparative study of solvent-assisted pretreatment of biodiesel derived crude glycerol on growth and 1,3-propanediol production from *Citrobacter freundii*., *N. Biotechnol.* 29 (2012) 199–205.
- [119] A. Rehman, M. Matsumura, N. Nomura, S. Sato, Growth and 1, 3-propanediol Production on Pre-Treated Sunflower Oil Bio-Diesel Raw Glycerol Using a Strict Anaerobe-*Clostridium butyricum*, *Curr. Res. Bacteriol.* 1 (2008) 7–16.
- [120] N.T. Keen, Specific elicitors of plant phytoalexin production: Determinants of race specificity in pathogens?, *Science* (80-. ). 187 (1975) 74–75.
- [121] R. Radman, T. Saez, C. Bucke, T. Keshavarz, Elicitation of plants and microbial cell systems., *Biotechnol. Appl. Biochem.* 37 (2003) 91–102.
- [122] M. Petruccioli, F. Federici, C. Bucke, T. Keshavarz, Enhancement of glucose oxidase production by *Penicillium variable* P16, *Enzyme Microb. Technol.* 24 (1999) 397–401.
- [123] Z. Yang, J.-P. Li, H. Guan, Preparation and characterization of oligomannuronates from alginate degraded by hydrogen peroxide, *Carbohydr. Polym.* 58 (2004) 115–121.

- [124] E. Asilonu, C. Bucke, T. Keshavarz, Enhancement of chrysogenin production in cultures of *Penicillium chrysogenum* by uronic acid oligosaccharides, *Biotechnol. Lett.* 22 (2000) 931–936.
- [125] J.G. Greene, R.H.P. Porter, R. V Eller, J.-T. Greenamyre, Inhibition of Succinate Dehydrogenase by Malonic Acid Produces an “Excitotoxic” Lesion in Rat Striatum, *J. Neurochem.* 61 (1993) 1151–1154.
- [126] H. Chen, H.U. Kim, H. Weng, J. Browse, Malonyl-CoA Synthetase, encoded by *ACYL ACTIVATING ENZYME13*, is essential for growth and development of *Arabidopsis*, *Plant Cell Online.* 23 (2011) 2247–2262.
- [127] S. Rugasaseel, S. Morikawa, K. Kirimura, S. Usami, S. Rugsaseel, Stimulation of citric acid production in *Aspergillus niger* by addition of viscous substances in shake culture, *Appl. Microbiol. Biotechnol.* 42 (1995) 839–843.
- [128] Y. Chisti, M.C. Flickinger, Shear Sensitivity, in: *Encycl. Ind. Biotechnol.*, John Wiley & Sons, Inc., 2009. doi:10.1002/9780470054581.eib543.
- [129] J.C. van Suijdam, B. Metz, Influence of engineering variables upon the morphology of filamentous molds, *Biotechnol. Bioeng.* 23 (1981) 111–148.
- [130] H. El-Enshasy, Filamentous Fungal Cultures - Process Characteristics, Products, and Applications, in: *Bioprocess. Value-Added Prod. from Renew. Resour. New Technol. Appl.*, 2007: pp. 225–261.
- [131] S.P. Bocking, M.G. Wiebe, G.D. Robson, K. Hansen, L.H. Christiansen, A.P. Trinci, Effect of branch frequency in *Aspergillus oryzae* on protein secretion and culture viscosity, *Biotechnol. Bioeng.* 65 (1999) 638–648.

- [132] Q. Xiong, S.A. Hassan, W.K. Wilson, X.Y. Han, G.S. May, J.J. Tarrand, et al., Cholesterol Import by *Aspergillus fumigatus* and Its Influence on Antifungal Potency of Sterol Biosynthesis Inhibitors, *Antimicrob. Agents Chemother.* . 49 (2005) 518–524.
- [133] N. Jacquier, R. Schneider, Mechanisms of sterol uptake and transport in yeast, *J. Steroid Biochem. Mol. Biol.* 129 (2012) 70–78.
- [134] S.-Y. Park, E. Jeon, S. Lee, J. Lee, T. Lee, J.-I. Won, An analysis of the concentration change of intermediate metabolites by gene manipulation in fatty acid biosynthesis, *Enzyme Microb. Technol.* 51 (2012) 95–99.
- [135] Ž. Polona, P. Aleksander, The Morphology of Filamentous Fungi in Submerged Cultivations as a Bioprocess Parameter, *Food Technol. Biotechnol.* 39 (2001) 727.

# Appendices

## Crude glycerol MSDS and content

### MATERIAL SAFETY DATA SHEET

Not classified as hazardous



Issue Date: July 2009

---

#### 1. IDENTIFICATION OF THE MATERIAL AND SUPPLIER

---

**Product Name:** Crude Glycerine  
**Other Names:** Glycerol; 1,2,3-Propanetriol  
**Recommended Use:** Suitable for further processing, for industrial and cosmetic applications  
**Supplier Name:** Biodiesel Producers Limited  
**Address:** 1456 Plemings Road  
Bamawartha VIC 3688  
**Telephone:** 02 6042 8400  
**Emergency Telephone:** 02 6042 8400  
Poisons Information Centre: 131126

---

#### 2. HAZARDS IDENTIFICATION

---

Not classified as hazardous according to criteria of NOHSC.  
Not classified as dangerous goods according to the Australian Dangerous Goods Code.

---

### 3. COMPOSITION / INFORMATION ON INGREDIENTS

---

Typical Composition:	CAS Number	Proportion
1,2,3-Propanetriol	56-81-5	>45%
Matter (Organic) Non-Glycerol		<20%
MeOH	67-56-1	<5%
Water	7732-18-5	<15%

---

### 4. FIRST AID MEASURES

---

**Inhalation:** Remove from area of exposure; seek medical attention if symptoms persist.

**Eyes:** Irrigate eyes with water for at least 5 minutes, holding eyelids open. Seek medical attention if irritation persists.

**Skin:** Wash exposed areas with soap and water. Remove contaminated clothing.

**Ingestion:** Remove material from mouth. Give plenty of water to drink. Induce vomiting if large amounts ingested and seek medical attention.

---

### 5. FIRE FIGHTING MEASURES

---

**Suitable Extinguishing Media:** Water spray, foam, CO<sub>2</sub> and dry powder.

**Hazards from Combustion Products:** Combustible liquid. If burning, may emit toxic fumes - acrolein.

**Precautions for Fire Fighters and Special Protective Equipment:** Use water spray to cool containers exposed to fire. Firefighters should use self-contained breathing apparatus to avoid exposure to smoke and vapour.

---

### 6. ACCIDENTAL RELEASE MEASURES

---

**Emergency Procedures:** Remove sources of ignition, increase ventilation. Contain spill to smallest area possible. Stop leak if possible. Do not allow product to reach drains, sewers or waterways.

**Methods and Materials for Containment and Clean Up Procedures:** Contain and pick up small spills with absorbent materials such as paper towels, Sphagsorb, sand or earth.

Recover large spills for salvage or disposal. Clean affected area.

**The source of crude glycerol used, and the initial analysis from the company.**

## HPLC optimization and standard curve

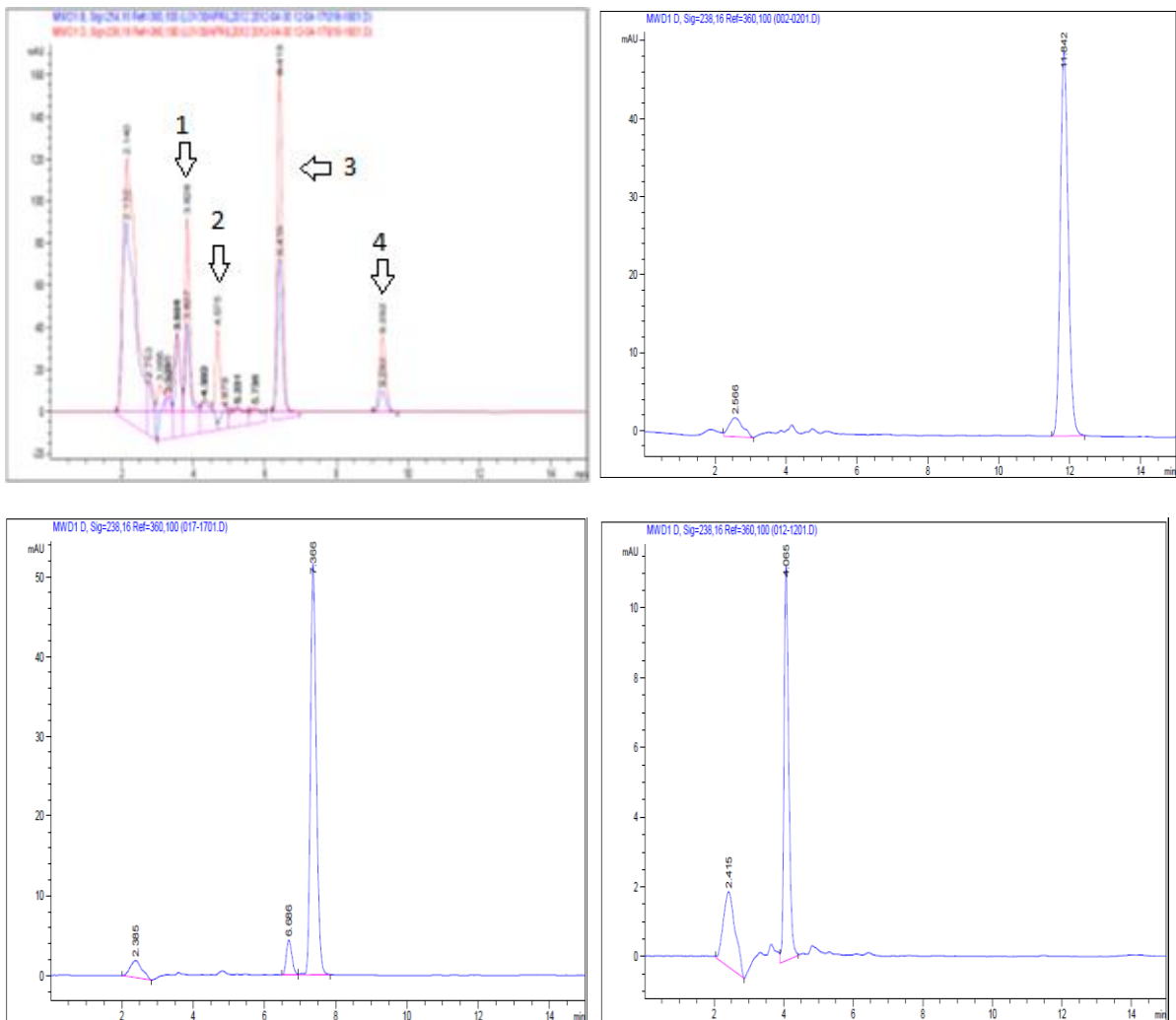

**Top left: Example of analysis of samples, showing lovastatin, (+)-geodin, sulochrin.** Top left: The HPLC chromatogram showing major metabolite peaks. (1) correspond to sulochrin, (2) is unknown, (3) is (+)-geodin and (4) is lovastatin. Top right: lovastatin standard peak. Bottom left: (+)-geodin standard peak. Small peak was detected as results of breakdown after prolong storage. Bottom right: Sulochrin standard peak.

## Inductively coupled plasma mass spectrometry (ICP) elements and preparation

Element	Conc (mg/L)	1 <sup>st</sup> dil	2 <sup>nd</sup> dil	3 <sup>rd</sup> dilution
Al	40	20	10	5
B	100	50	25	12.5
Ba	40	20	10	5
Be	10	5	2.5	1.25
<b>Cd</b>	<b>10</b>	<b>5</b>	<b>2.5</b>	<b>1.25</b>
<b>Co</b>	<b>10</b>	<b>5</b>	<b>2.5</b>	<b>1.25</b>
<b>Cr</b>	<b>20</b>	<b>10</b>	<b>5</b>	<b>2.5</b>
<b>Cu</b>	<b>20</b>	<b>10</b>	<b>5</b>	<b>2.5</b>
Fe	100	50	25	12.5
<b>Mn</b>	<b>10</b>	<b>5</b>	<b>2.5</b>	<b>1.25</b>
<b>Ni</b>	<b>20</b>	<b>10</b>	<b>5</b>	<b>2.5</b>
<b>Pb</b>	<b>40</b>	<b>20</b>	<b>10</b>	<b>5</b>
Se	100	50	25	12.5
<b>Tl</b>	<b>100</b>	<b>50</b>	<b>25</b>	<b>12.5</b>
V	40	20	10	5
Zn	100	50	25	12.5

**The heavy metals elements and the concentration used for ICP analysis.** The elements of interest are in bold.

## Real-time RT PCR

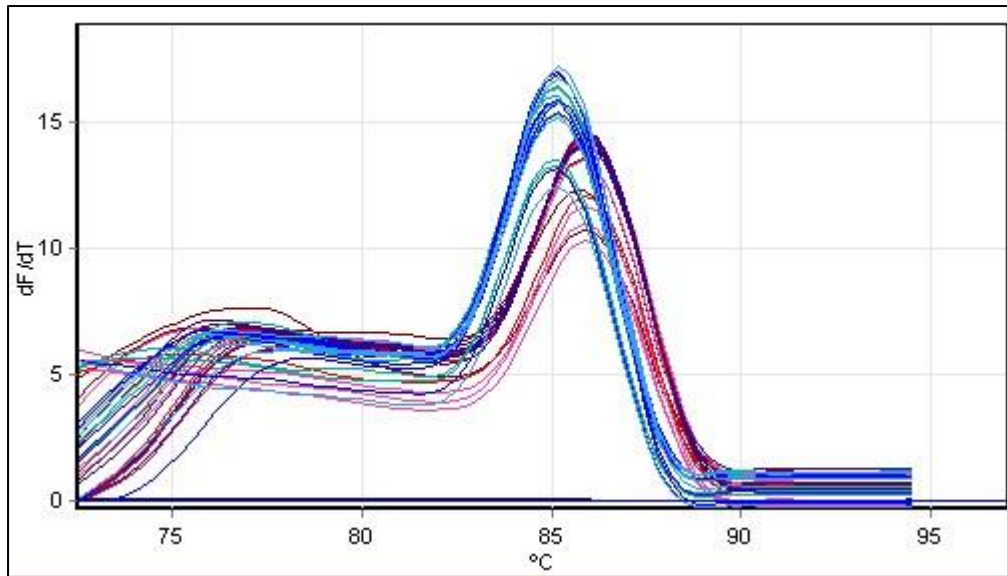

**Examples of melt curve generated by Rotor Gene software.** Note that there were two different peaks, which indicates that the primer bind at two different spots in the genome.

Gene	Gene accession number	Oligonucleotide sequence 5'→3'	Size (bp)
<b>lovB</b>	ATEG_09961	forward: CCG CCT TAA TGA TTG CTG GC reverse: ACG TCA GCT GTC AGG TTG AG	<b>110</b>
<b>β-actin</b>	ATEG_06973	forward: CTT CCC CTC CAT TGT CGG TC reverse: TGG GGT ATC TGA GGG TGA GG	<b>182</b>

**The different primer pairs utilised in real time RT-PCR.** All primers were constructed using Primer3 software.



## Primer validation and optimization

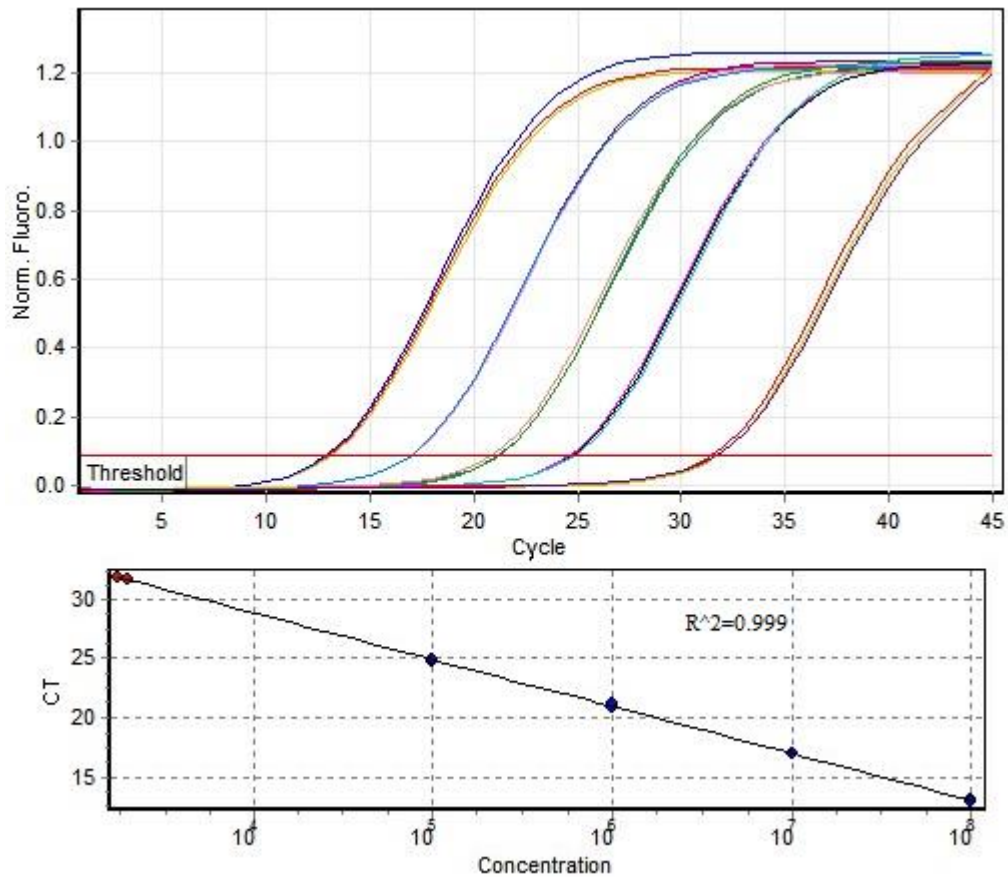

The example of report generated by RT-PCR software during primer optimization procedure showing a) Serial dilution of lovB b) R<sup>2</sup> value and c) Threshold point was set up at 0.089.

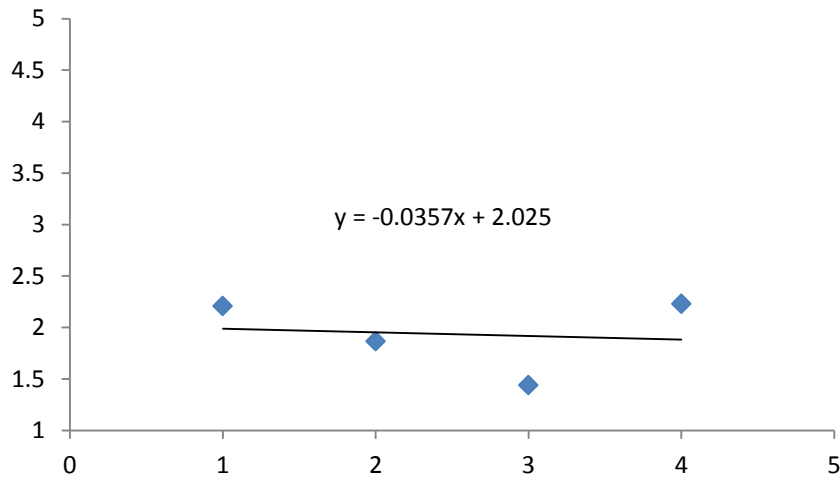

**Comparison of reaction efficiencies of lovB with  $\beta$ -actin.** A linear regression with slope,  $m \leq \pm 0.1$  indicates that PCR efficiencies were equal.

	<b>lovB</b>	<b><math>\beta</math>-actin</b>
Reaction Efficiency (%)	80	94
Reproducibility ( $R^2$ )	0.99	0.97

**Reaction efficiency and reproducibility values for each of the standard curves generated for the genes of interest and endogenous reference gene.** The optimum reaction efficiency should fall in between 80% to 110%, while the reproducibility ( $R^2$ ) for each standard curve should be around 0.99.