

Hookworm infection in the Australian sea lion
(*Neophoca cinerea*)

Alan David Marcus

A thesis submitted in fulfilment of the requirements for the degree of

Doctor of Philosophy

Faculty of Veterinary Science

The University of Sydney

2015

Statement of authentication

This thesis is submitted to the University of Sydney in fulfilment of the requirements for the degree of Doctor of Philosophy.

The work presented in this thesis is, to the best of my knowledge and belief, original except as acknowledged in the text. I hereby declare that I have not submitted this material, either in full or in part, for a degree at this or any other institution.

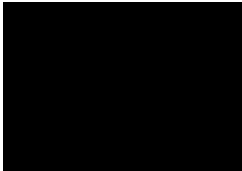

Alan David Marcus

June 2015

Summary of the thesis

Parasites are integral components of biodiverse ecosystems and profoundly impact the health and population dynamics of many free-ranging species. The sequelae of parasitic infection fluctuate along a continuum from beneficial to detrimental host effects, mediated by the dynamic interaction of host, pathogen, and environment factors. Understanding the effects of parasitic infection, and the fundamental factors influencing the epidemiology of disease, is essential to determining the need for, and approach to, control strategies to conserve complex ecosystems. For the Australian sea lion (*Neophoca cinerea*), an endangered keystone predator that demonstrates high rates of pup mortality and limited population recovery, an understanding of the role of infectious disease in influencing pup health, and how it may contribute towards shaping population demography, is a key knowledge gap. Preliminary investigations indicated that hookworm (*Uncinaria* sp.) infection is an important cause of disease and mortality in Australian sea lion pups. These findings were the impetus for this thesis to investigate the taxonomy, epidemiology, clinical impact, and management of hookworm infection in the Australian sea lion.

Chapter 1 of this thesis describes the natural history of the Australian sea lion and outlines the key threats and knowledge gaps pertaining to the species' survival. The state of knowledge regarding hookworm infection in pinnipeds is reviewed and the aims of this thesis are presented.

Field work for this study was undertaken at two major colonies of the Australian sea lion in South Australia – Seal Bay, Kangaroo Island, and Dangerous Reef, Spencer Gulf – during consecutive breeding seasons in 2010–2013. These colonies were selected primarily for their disparate biogeographical features and opposite seasonal patterns of variation in pup mortality, facilitating investigation of the role of host, pathogen, and

environment factors in influencing the epidemiology and clinical impact of hookworm infection in this species.

Hookworms collected from Australian sea lion pups were identified and described in Chapter 2 as a single, novel species (*Uncinaria sanguinis*). Substantial inter-host morphometric variation in both juvenile and adult specimens of *U. sanguinis* was identified, demonstrating the limited utility of quantitative morphometrics to discriminate between different *Uncinaria* species, which engenders caution when delimiting new species. However, morphological features and differences in nuclear ribosomal DNA sequences clearly delineated *U. sanguinis* from named congeners. By determining the taxonomic identity of hookworms parasitising Australian sea lion pups, this study provided a solid foundation to investigate the epidemiology, clinical impact, and management of this parasite.

Findings presented in Chapters 2, 3, and 5 indicate that, as for hookworm infection in other otariid species, transmammary transmission in the immediate post-parturient period is likely the predominant route leading to patent hookworm infection in Australian sea lion pups. However, in contrast to the fundamental role that colony substrate appears to play in shaping the epidemiology of hookworm infection in these other hosts, the findings of Chapter 3 demonstrate that 100 % of Australian sea lion pups are infected with *U. sanguinis* irrespective of the type of colony substrate, and that the intensity of hookworm infection (mean intensity of 2138 hookworms per pup) appears to be influenced by colony-specific seasonal differences in host behaviour. Seasonal fluctuations in the intensity of hookworm infection corresponded to oscillations in the magnitude of colony pup mortality; higher hookworm infection intensity was associated with higher colony pup mortality as well as reduced pup body condition. This study implicates *U. sanguinis* as a key factor shaping the population demography of the Australian sea lion and provides a new

perspective to understanding the fundamental factors that influence the dynamics of hookworm infection in otariids.

Chapter 4 of this thesis improves the understanding of the impact of infectious disease on the health status of Australian sea lion pups by estimating the effects of pathogen, host, and environment factors on the values of haematological parameters. In addition, haematological reference intervals were developed for free-ranging Australian sea lion pups within the context of endemic hookworm infection to facilitate health assessment. *Uncinaria sanguinis* was identified as a significant agent of disease, with infection causing regenerative anaemia, hypoproteinaemia, and a predominantly lymphocytic-eosinophilic systemic inflammatory response. Further evidence that *U. sanguinis* causes intensity-dependent disease in pups was provided by the findings of higher eosinophil counts and lower total plasma protein values during high hookworm infection intensity seasons compared to low hookworm infection intensity seasons at both colonies. Interestingly, the degree of eosinophilia observed in this study was markedly higher than that previously reported for other otariid pups, possibly reflective of the higher intensity and pathogenicity of hookworm infection in Australian sea lion pups. This study demonstrated the significant adverse impact that *U. sanguinis* has on the health status of Australian sea lion pups and, by demonstrating that the occurrence of neonatal anaemia is not solely a benign physiological response to host-environment changes in this species, challenges assumptions about the non-pathological nature of neonatal anaemia in other pinnipeds.

Chapter 4 also presents findings on the epidemiology and clinical impact of sucking lice (*Antarctophthirus microchir*) infestation in Australian sea lion pups. This parasite was identified commonly on pups (> 70 % prevalence) but, in contrast to hookworm infection, the clinical impact of infestation was less severe, associated only with mild anaemia and

hyperproteinaemia, and is considered unlikely to be having a significant impact on the health status of Australian sea lion pups. In addition, findings in Chapters 4 and 5 indicate that the prevalence and intensity of lice infestation may increase secondary to hookworm infection, suggesting that some of the effects attributed to *A. microchir* are correlatively, rather than causatively, associated with their occurrence.

Chapter 5 reports the results of investigations at Dangerous Reef to test the association of *U. sanguinis* with disease in Australian sea lion pups by experimentally manipulating the host-parasite relationship via anthelmintic administration. Ivermectin was found to be highly effective (97.9 %) at eliminating *U. sanguinis* from pups and was also effective (91.4 %) at removing *A. microchir* for up to 2 months. As such, it was not possible to definitively distinguish between the independent effects of these parasites, however, given that *U. sanguinis* was otherwise identified to have greater pathological impact than *A. microchir*, it is likely that the changes observed in clinical parameters in treated pups were predominantly due to the elimination of hookworm infection. Pups administered ivermectin had significantly higher erythrocyte counts and significantly lower eosinophil counts relative to saline-treated control pups at 1–2 months post-treatment. Unexpectedly, ivermectin treatment was not significantly associated with beneficial effects on pup growth and survival, highlighting the challenges associated with treating pups of this species shortly after birth at a remote colony. This study contributes towards understanding the utility of anthelmintic treatment as a tool for the conservation management of free-ranging wildlife and outlines essential steps to further the development of strategies to ensure the effective conservation of the Australian sea lion and its parasitic fauna.

Chapter 6 discusses the significance of the major findings of the studies in this thesis and their implications for the conservation management of the Australian sea lion.

Limitations of the studies are also discussed and directions for future research are proposed. The baseline epidemiological data and the haematological reference intervals described in this thesis can facilitate the implementation of long-term health surveillance in this species, which is critical for the early recognition of emerging disease and changes in disease impact so that interventional strategies can be implemented. This thesis determined that *U. sanguinis* is an important cause of disease in the Australian sea lion and implicated this parasite as a major factor contributing towards pup mortality. As such, this body of work contributes towards an improved understanding of the role of infectious disease in influencing the health status and population demography of this endangered species, informing conservation management and providing a solid foundation for further investigations of the effect of disease on the health status of this and other free-ranging species.

Acknowledgements

This thesis would not have been possible without the contributions of many people. I am immensely grateful for the support and guidance of my supervisory team, Rachael Gray, Damien Higgins, and Jan Šlapeta. Rachael, thank you for always being available, for the extensive time you committed to field work, and for truly going above and beyond in your dedication to this project and my development as a researcher. Your fast turn-around to provide thorough and detailed comments on drafts is greatly appreciated. Damien, thank you for the fun times in the field, for the philosophical discussions, and for always challenging me to think deeper. Jan, thank you for welcoming me warmly into the parasitology group and for engaging with me in, at times lengthy, disputatious discussions. You have been a source of inspiration and a driving force to ‘get it done’.

The Australian Marine Mammal Centre, Department of the Environment, Australian Government provided critical funding for this project and my PhD scholarship. Additional funding support was generously provided by the Winifred Violet Scott Foundation, and the Whitehead Bequest in Wildlife Conservation, Faculty of Veterinary Science, The University of Sydney.

I would like to thank all of the staff of the Faculty of Veterinary Science, The University of Sydney, who have contributed towards creating a fantastic research environment. In particular, I would like to thank Denise McDonell for her help in the parasitology lab and her tolerance of the malodorous sea lion faecal samples. Thank you to Christine Gotsis and George Tsoukalas of the Veterinary Pathology Diagnostic Service for their assistance with haematological reagents and sample analysis. Thank you to Navneet Dhand, Peter Thompson, and Evelyn Hall of the Faculty of Veterinary Science, The University of Sydney, and Michael Terkildsen for their generous assistance with statistics.

Many thanks to the staff at Seal Bay, Department of Environment, Water and Natural Resources (DEWNR), South Australia, who always made me feel welcome and provided me with countless rides to and from Kingscote, field assistance, and much humour. In particular, I am indebted to Clarence Kennedy and Janet Simpson for their help. Clarry, your skill and assistance in the field was invaluable and always generously available; thanks for the fun times, although I will always question your ability to predict the weather and the size of waves. Janet, you kindly opened your house to provide us with a second home and lab on KI; thank you for your amazing support and generosity.

Thanks also to Tony Jones and Adam Kemp of Protec Marine, Port Lincoln, South Australia, for providing essential transport and logistical support for field work at Dangerous Reef.

Thank you to the many friends and colleagues who generously donated their time to volunteer and assist with field work, including: Liisa Ahlstrom, Loreena Butcher, Michael Edwards, Simon Goldsworthy, Benjamin Haynes, Claire Higgins, Janet Lackey, Zoe Larum, Theresa Li, Andrew Lowther, Paul Rogers, Laura Schmertmann, Adrian Simon, Ryan Tate, Michael Terkildsen, Mark Whelan, Peter White, Sy Woon, and Mariko Yata.

I would also like to thank my fellow research students, in particular, Lisa Black, Christie Foster, Quintin Lau, Iona Maher, Caroline Marschner, Vickie Morin-Adeline, Hayley Pearson, Mark Westman, and Mariko Yata, for their friendship, procrastination chats, innumerable Newtown Thai lunches, and Carcassonne games. Finally, thank you to my family, in particular to my amazing partner Mariko, for their support throughout this journey.

Table of contents

Statement of authentication	i
Summary of the thesis	ii
Acknowledgements	vii
Publications and conference presentations arising from candidature	x
Chapter 1. Introduction, literature review, and aims of the thesis	1
Chapter 2. <i>Uncinaria sanguinis</i> sp. n. (Nematoda: Ancylostomatidae) from the endangered Australian sea lion, <i>Neophoca cinerea</i> (Carnivora: Otariidae)	33
Chapter 3. Epidemiology of hookworm (<i>Uncinaria sanguinis</i>) infection in free-ranging Australian sea lion (<i>Neophoca cinerea</i>) pups	47
Chapter 4. Health assessment of free-ranging endangered Australian sea lion (<i>Neophoca cinerea</i>) pups: effect of haematophagous parasites on haematological parameters	63
Chapter 5. Ivermectin treatment of free-ranging endangered Australian sea lion (<i>Neophoca cinerea</i>) pups: effect on hookworm and lice infection status, haematological parameters, growth, and survival	83
Chapter 6. Discussion	98
References	116

Publications and conference presentations arising from candidature

Journal articles

Marcus AD, Higgins DP, Šlapeta J, Gray R (2014) *Uncinaria sanguinis* sp. n. (Nematoda: Ancylostomatidae) from the endangered Australian sea lion, *Neophoca cinerea* (Carnivora: Otariidae). *Folia Parasitol* 61:255–265. doi:10.14411/fp.2014.037

Marcus AD, Higgins DP, Gray R (2014) Epidemiology of hookworm (*Uncinaria sanguinis*) infection in free-ranging Australian sea lion (*Neophoca cinerea*) pups. *Parasitol Res* 113:3341–3353. doi:10.1007/s00436-014-3997-3

Marcus AD, Higgins DP, Gray R (2015) Health assessment of free-ranging endangered Australian sea lion (*Neophoca cinerea*) pups: effect of haematophagous parasites on haematological parameters. *Comp Biochem Physiol A Mol Integr Physiol* 184:132–143. doi:10.1016/j.cbpa.2015.02.017

Marcus AD, Higgins DP, Gray R (2015) Ivermectin treatment of free-ranging endangered Australian sea lion (*Neophoca cinerea*) pups: effect on hookworm and lice infection status, haematological parameters, growth, and survival. *Parasitol Res*. doi:10.1007/s00436-015-4481-4

Haynes BT, **Marcus AD**, Higgins DP, Gongora J, Gray R, Šlapeta J (2014) Unexpected absence of genetic separation of a highly diverse population of hookworms from geographically isolated hosts. *Infection, Genetics and Evolution* 28:192–200. doi:10.1016/j.meegid.2014.09.022

Conference presentations

Marcus AD, Higgins DP, Gray R (2012) Ivermectin treatment of free-ranging Australian sea lion pups: effect on hookworm infection status, pup growth and survival, and haematological parameters. Paper presented at the Wildlife Disease Association – Australasian Conference, North Stradbroke Island, Australia, 24–28 September

Marcus AD, Higgins DP, Gray R (2013) Determining the prevalence of hookworm infection in the Australian sea lion. Paper presented at the Australian/New Zealand Student Chapter of the Society for Marine Mammalogy Conference, Phillip Island, Australia, 3–5 July

Marcus AD, Higgins DP, Gray R (2013) Prevalence and intensity of hookworm (*Uncinaria* sp.) infection in free-ranging Australian sea lion (*Neophoca cinerea*) pups. Paper presented at the Wildlife Disease Association – Australasian Conference, Grampians, Australia, 29 September – 4 October

Marcus AD, Higgins DP, Šlapeta J, Gray R (2013) Haematophagous hookworm (*Uncinaria* sp.) associated with high pup mortality in Australian sea lions (*Neophoca cinerea*). Paper presented at the 20th Biennial Conference on the Biology of Marine Mammals, Dunedin, New Zealand, 9–13 December

Marcus AD, Higgins DP, Gray R (2015) Anaemia in neonatal pinnipeds: distinguishing between correlation and causation by haematophagous parasites of the Australian sea lion. Paper to be presented at the 64th Annual International Conference of the Wildlife Disease Association, Sunshine Coast, Australia, 26–30 July

Chapter 1

Introduction, literature review, and aims of the thesis

Chapter 1 Introduction, literature review, and aims of the thesis

1.1 Introduction

Parasites are integral components of biodiverse ecosystems and profoundly impact the health and population dynamics of many free-ranging species (Smith et al. 2009; Thompson et al. 2010). The sequelae of parasitic infection fluctuate along a continuum from beneficial to detrimental host effects, mediated by the dynamic interaction of host, pathogen, and environment factors (Leung and Poulin 2008). For example, parasitic infection may be associated with clinical or subclinical disease, which can be evident by alterations in haematological values, changes in behaviour, and/or reduced growth rates, and can contribute directly or indirectly towards mortality (Irvine 2006; Bordes and Morand 2011). Conversely, parasites may confer an advantage to their host by modulating immunological responses, improving survival by delaying physiologically expensive activities such as reproduction, or increasing sexual attractiveness (Thomas et al. 2000; Yazdanbakhsh et al. 2002; Telfer et al. 2005). Understanding the effects of parasitic infection in free-ranging species, and the fundamental factors influencing the epidemiology of disease, is essential to quantifying the impact of parasites on population health and dynamics and to inform conservation management as to the need for, and approach to, control strategies.

The Australian sea lion (*Neophoca cinerea*) is an endangered (IUCN Red List of Threatened Species; Goldsworthy and Gales 2008) and vulnerable (Environment Protection and Biodiversity Conservation Act 1999) pinniped species endemic to Australia. The three major breeding colonies demonstrate high rates of pup mortality (The Pages Islands: mean 17 %, range 3–56 % – Shaughnessy et al. 2013; Seal Bay: mean 29 %, range 20–41 % – Goldsworthy et al. 2014a; Dangerous Reef: mean 24 %, range 10–45 % – Goldsworthy et al. 2014b) that likely contribute towards limiting population recovery

(McIntosh et al. 2013). Pup mortality oscillates between the low and high ends of the observed range at Seal Bay for winter and summer breeding seasons, respectively, and the opposite seasonal association occurs at Dangerous Reef (Goldsworthy et al. 2014a; Goldsworthy et al. 2014b). In contrast, seasonal patterns of variation in pup mortality are not readily apparent at The Pages Islands (Shaughnessy et al. 2013). Most Australian sea lion pup mortality occurs before 1–2 months of age and has been largely attributed to conspecific trauma and starvation (Higgins and Tedman 1990; McIntosh et al. 2012; McIntosh and Kennedy 2013); however, an understanding of the role of infectious disease in pup mortality, and how it may contribute towards seasonal patterns of pup mortality, is a key knowledge gap for this species (Goldsworthy et al. 2009a; Australian Government 2013a and 2013b; McIntosh and Kennedy 2013).

Hookworms (*Uncinaria* spp.) are haematophagous parasitic nematodes predominantly of the small intestine. They are associated with anaemia, reduced growth rates, and mortality of pups in several otariid species (Lyons et al. 2001; Chilvers et al. 2009; DeLong et al. 2009; Seguel et al. 2011). Greater hookworm infection intensity and prevalence, and subsequently more severe disease outcomes, have been associated with high host density and sandy substrates compared to low host density and rocky substrates (Lyons et al. 2000b). Historically, only two species of *Uncinaria* were described from pinnipeds, yet the identification of ‘intermediate’ morphotypes, unknown host specificity, and the potential for host-dependent morphological variation contributed towards the uncertainty of how many distinct *Uncinaria* species parasitise pinnipeds (Baylis 1933; Baylis 1947; George-Nascimento et al. 1992). Recent molecular investigations have demonstrated the existence of greater hookworm species diversity as well as the occurrence of parasite-sharing between several pinniped hosts (Nadler et al. 2000; Lyons et al. 2011a; Nadler et al. 2013; Ramos et al. 2013); however, the taxonomic identity of

hookworms parasitising the Australian sea lion is unresolved. The relative pathogenicity of different hookworm species in pinnipeds has not been determined due to this taxonomic uncertainty and the confounding effects of differential host and environment factors on the expression of disease.

Preliminary investigations of the health of Australian sea lion pups indicated that hookworm infection is an important cause of disease and mortality in this species (R. Gray, pers. comm.). These findings were the impetus for this study to address knowledge gaps pertaining to the taxonomy, epidemiology, and clinical impact of hookworm infection in the Australian sea lion and to investigate the utility of anthelmintic treatment as a tool for the conservation management of this endangered species. More broadly, the life history of the Australian sea lion and the disparate biogeographical features of some of their breeding colonies offer a unique comparative system to investigate host-pathogen-environment relationships in the epidemiology and clinical impact of hookworm infection in neonatal pinnipeds.

The remainder of this chapter describes the natural history of the Australian sea lion and outlines the key threats and knowledge gaps pertaining to the species' survival. The taxonomy, epidemiology, clinical impact, and management of hookworm infection in pinnipeds are then reviewed. Finally, the aims of this thesis are presented.

1.2 The Australian sea lion

The Australian sea lion is a marine mammal in the order Carnivora, family Otariidae. Traditionally, Otariidae was subdivided into Otariinae (sea lions) and Arctocephalinae (fur seals), the latter exhibiting a dense layer of underfur. However, morphological and molecular analyses indicate a complex evolutionary history that does not support this taxonomic subdivision (Churchill et al. 2014). Otariids are characterised

by the presence of external pinnae and the ability to rotate their hindflippers cranially, which facilitates terrestrial agility. In contrast, members of the closely related Phocidae family lack external pinnae – hence, the vernacular name ‘earless seals’ – and are unable to turn their hindflippers cranially; phocids are relatively less agile on land compared to otariids, relying upon undulating body movements for locomotion. Similar to phocids, the only extant representative of the Odobenidae family, the walrus (*Odobenus rosmarus*), lack external pinnae but are able to rotate their hindflippers cranially like otariids. The walrus also features characteristically elongated maxillary canine teeth (tusks). Collectively, Otariidae (sea lions and fur seals), Phocidae (seals), and Odobenidae (walruses) are referred to as ‘pinnipeds’.

Australian sea lions demonstrate marked sexual dimorphism: adult males (Figs. 1 and 2) are typically dark brown in colour with a creamy-white dorsal head cap and weigh 180–250 kg with standard length of 185–250 cm; adult females (Figs. 2 and 3) are typically silver-grey to brown dorsally with creamy-white ventral colouration and weigh 61–104 kg with standard length of 130–185 cm (Ling 1992; Kirkwood and Goldsworthy 2013). Males are sexually mature from approximately 5 years of age but are unlikely to successfully compete and mate until approximately 6–12 years of age, whereas females are sexually mature from 3 years of age (Ling 1992; McIntosh 2007). Juveniles of both sexes are similar in colouration to adult females with significant sexual dimorphism evident from 1–3 years of age (McIntosh 2007). Neonatal pups (Fig. 3) vary in colour from grey-black to brown with their first moult commencing at approximately 3–4 months of age, after which they have the pelage of juveniles (Gales et al. 1994). Data on the size of neonatal pups is limited; a small study of dead newborn pups reported weights of 4–8 kg with standard length of 58–75 cm (McIntosh and Kennedy 2013).



Fig. 1 Australian sea lion adult males competing to mate. Seal Bay, Kangaroo Island.



Fig. 2 Parturient Australian sea lion adult female mate guarded by an adult male. Dangerous Reef, Spencer Gulf.



Fig. 3 Australian sea lion adult females and neonatal pups on a range of substrate types at Seal Bay, Kangaroo Island.

Australian sea lions exploit the aquatic environment to meet their nutritional requirements and utilise terrestrial environments for rest and reproduction. Dive-behaviour studies indicate that Australian sea lions are predominantly central-place benthic foragers (Costa and Gales 2003; Fowler et al. 2007a; Lowther et al. 2011; Lowther et al. 2013); these findings are supported by analyses of regurgitate and stomach contents (McIntosh et al. 2006a), milk fatty acids (Baylis et al. 2009), and faecal DNA (Peters et al. 2014) that demonstrate that Australian sea lions predominantly prey upon cephalopod, crustacea, and benthopelagic fish. The aquatic areas utilised are extensive and vary according to gender and age class with individuals demonstrating specific preferences for certain habitat types (Baylis et al. 2009; Lowther and Goldsworthy 2010; Lowther et al. 2011; Lowther et al. 2013); limited data suggests that the foraging locations of individual Australian sea lions is relatively insensitive to environmental changes, with individuals exhibiting seasonal

variation in the composition of consumed prey rather than foraging locations (Lowther et al. 2013).

This foraging site fidelity likely helps maintain the high degree of Australian sea lion female natal site fidelity (Higgins and Gass 1993), which results in substantial intercolony genetic subdivision of maternal lineages (Campbell et al. 2008a; Lowther et al. 2012). In addition, the duration of foraging trips are typically only 2–3 days for adult females – possibly limited by the nutritional requirements of their dependent pups – and mean distance travelled is less than 90 km, effectively restricting mixing of adult females between most colonies (Costa and Gales 2003; Fowler et al. 2007a; Lowther and Goldsworthy 2011; Lowther et al. 2011). In contrast, intercolony movements have been observed for adult male Australian sea lions with individual males recorded travelling up to 440 km in a single trip and at-sea durations of up to 9 days (Lowther et al. 2013); however, the extent of male-mediated gene-flow between colonies has not been established.

The reproductive biology of the Australian sea lion is unique amongst pinnipeds and may act to further limit the migration of breeding females between colonies (Campbell et al. 2008a; Lowther et al. 2012). The timing of the breeding season in most pinniped species is hypothesised to be influenced by endogenous factors such as body condition and exogenous factors such as photoperiod, prey availability, and environmental variability. For most species, parturition occurs annually in summer, corresponding to periods of increased prey availability and optimal temperatures for pup survival (Boyd 1991; Soto et al. 2004; Gibbens and Arnould 2009). In contrast, the Australian sea lion exhibits an extended breeding cycle of approximately 18 months that occurs asynchronously between colonies (Higgins 1993; Gales et al. 1994; Shaughnessy et al. 2011; McIntosh et al. 2012). Furthermore, whereas the duration of most pinniped breeding seasons is approximately 1–2

months (reviewed by McIntosh 2007), most Australian sea lion pups are born over a 4–5 month period with the duration of breeding seasons extending up to 7–9 months at some colonies (Goldsworthy et al. 2012; McIntosh et al. 2012). The asynchronous timing of breeding between colonies and the prolonged period of pup dependence (pups are weaned after an average lactational period of 17.3 months; Higgins and Gass 1993), in combination with the high degree of foraging site fidelity, likely acts as a barrier to adult female dispersal, reinforcing selection for natal site fidelity (Campbell et al. 2008a; Lowther et al. 2012).

1.2.1 Population distribution and trends in abundance

The Australian sea lion population consists of approximately 15,000 individuals distributed across 76 colonies from The Pages Islands in South Australia (35.77 °S, 138.30 °E) to the Houtman Abrolhos Islands (28.46 °S, 113.70 °E) in Western Australia (Fig. 4; Goldsworthy et al. 2009a). This population size is based on recent estimates that 3,610 pups are born each breeding cycle; 3,107 pups (86 %) in South Australia and 503 pups (14 %) in Western Australia (Goldsworthy et al. 2009a). Population data for the Australian sea lion is generally poor across its range due to the species' extended breeding season, uncertainty of the timing of breeding seasons at different colonies, and the large number of colonies; these characteristics pose difficulties for accurately estimating pup production because the timing, frequency, and methodology of pup surveys can significantly affect the accuracy of pup counts (Goldsworthy et al. 2009a; Shaughnessy et al. 2011; McIntosh et al. 2012). As such, there is limited robust long-term data of trends in pup production for most colonies (McIntosh et al. 2012).

The current abundance and distribution of Australian pinnipeds is reduced compared to pre-European-colonisation levels, due primarily to the occurrence of

unregulated harvesting in the 18–20th centuries (Ling 1999). There is insufficient data to accurately determine the historical size of the Australian sea lion population, but harvesting records and observations indicate that colonies previously extended through the Bass Strait (Fig. 4) and that there was a loss and reduction in the abundance of colonies within the extant range (Gales et al. 1994; Ling 1999; Shaughnessy et al. 2005). Although it is likely that fewer Australian sea lions were killed than Australian fur seals (*Arctocephalus pusillus doriferus*) and long-nosed fur seals (*Arctophoca australis forsteri*)¹ as their pelage was not considered as valuable (Ling 1999), in contrast to the on-going exponential recovery of these fur seal populations following the cessation of harvesting, the Australian sea lion population remains small and there is considerable uncertainty about the extent of recovery (Goldsworthy et al. 2009a; Kirkwood et al. 2010; Shaughnessy et al. 2015). A third of the total Australian sea lion pup production occurs at three colonies in South Australia (Fig. 4): Seal Bay, Kangaroo Island (35.994 °S, 137.317 °E); Dangerous Reef, Spencer Gulf (34.815 °S, 136.212 °E); and The Pages Islands, Backstairs Passage (35.77 °S, 138.30 °E). Notwithstanding the aforementioned limitations of accurately estimating pup production in this species, the most robust data of trends in pup production are available for these three colonies.

¹ Following the recommendations of Shaughnessy and Goldsworthy (2014), I have used the vernacular name ‘long-nosed fur seal’ in preference to ‘New Zealand fur seal’ for *Arctophoca australis forsteri*. An exception is present in Chapter 2, the publication of which pre-dated this recommendation. Note, in this thesis and associated publications, pinniped taxonomic nomenclature follows Berta and Churchill (2012).

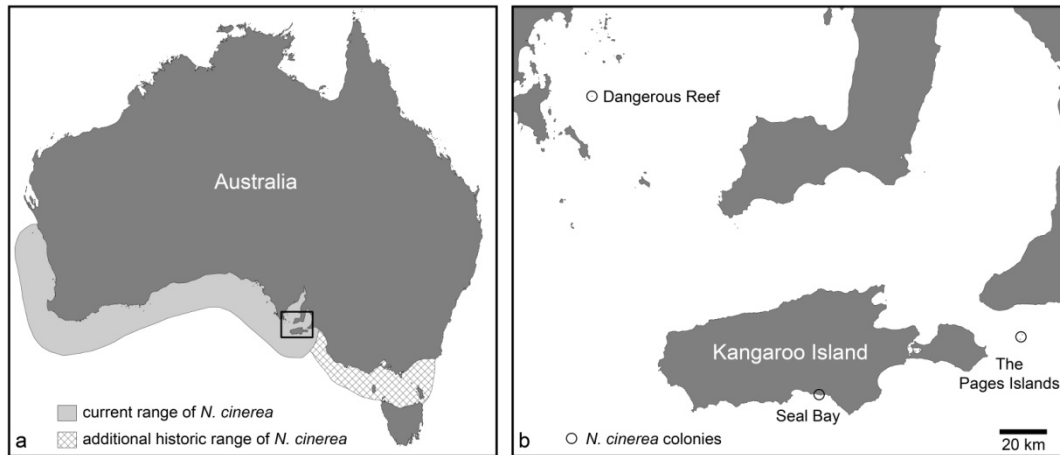

Fig. 4 (a) Current and historical range of the Australian sea lion (*N. cinerea*). **(b)** Location of the three largest breeding colonies for this species: Seal Bay, Dangerous Reef, and The Pages Islands. Adapted from Gales et al. (1994).

Seal Bay extends over approximately 3 km of sandy beaches, rocky coastal-platforms, and sand dunes covered predominantly with coast saltbush (*Atriplex cinerea*) and tea-tree (*Melaleuca lanceolata*) scrub, offering plentiful shelter for pups. Seal Bay is readily accessible – approximately 100,000 tourists visit this colony each year (Goldsworthy et al. 2014a) – and pups are routinely microchipped at approximately two months of age as part of ongoing demographic studies (McIntosh et al. 2012). Trends in pup production have been estimated using (1) maximum pup counts and (2) a recently implemented metric of pup production incorporating the number of observed births, the number of pups microchipped, and mark-recapture estimates (McIntosh et al. 2012; Goldsworthy et al. 2014a). Based on maximum pup counts for 20 consecutive breeding seasons between 1985 and 2013, pup production is significantly declining by 2 % each breeding season; however, no significant trend in pup production was identified using the new metric for eight consecutive breeding seasons between 2002 and 2013 (McIntosh et al. 2012; Goldsworthy et al. 2014a). A comparison of the two methods of estimating pup production at Seal Bay demonstrated that maximum pup counts are not a reliable measure

at this colony (McIntosh et al. 2012). As such, there remains considerable uncertainty about the historical and current trajectory of the Australian sea lion population at Seal Bay. Based on the new metric, approximate pup production is currently 250 pups per breeding season at this colony and pup mortality has oscillated between low mortality rates (mean 22 %, range 20–25 %) for breeding seasons occurring predominantly in winter, and high mortality rates (mean 35 %, range 32–41 %) for alternate breeding seasons occurring predominantly in summer (McIntosh et al. 2012; Goldsworthy et al. 2014a).

Dangerous Reef is a remote low-lying granite and limestone island approximately 250 m long and 100 m wide with minimal vegetation and a substrate consisting predominantly of rock and guano; shelter for pups is scarce. Access to Dangerous Reef is via sea transport and is dependent upon favourable weather conditions. At this colony, individually-numbered flipper tags are applied to pups to facilitate demographic studies and trends in pup production have been estimated using (1) maximum pup counts, (2) minimum live and cumulative dead pup counts, (3) mark-recapture estimates, and (4) “cumulative pup production methods” (methods outlined in Goldsworthy et al. 2010a and 2014b). However, the reliability of these measures is uncertain as they tend to estimate similar pup production values during winter breeding seasons but demonstrate marked variation during summer breeding seasons; differences in pup behaviour and survival between seasons may influence the accuracy of these methods, although there is insufficient data to robustly test these hypotheses (Goldsworthy et al. 2014b). Irrespective of the methodology to estimate pup production, no significant linear trends were identified for 13 breeding seasons between 1994 and 2014 (excluding the 2013 breeding season in which pup production was not estimated); the broad pattern in pup production was for an apparent increase from approximately 350 pups in 1994 to up to approximately 830 pups in 2006, followed by an apparent decline to approximately 500 pups in 2014 (Goldsworthy et

al. 2014b). Similar to Seal Bay, pup mortality also tends to oscillate between consecutive breeding seasons at Dangerous Reef, although the opposite seasonal association occurs, with low mortality rates observed for summer breeding seasons (based on the incidence of pup mortality at the time of maximum pup count; mean 15 %, range 10–23 %) and high mortality rates for winter breeding seasons (mean 29 %, range 12–45 %; Goldsworthy et al. 2014b).

The Pages Islands are two low-lying islands composed primarily of phyllite (a type of foliated metamorphic rock); North Page Island is approximately 400 m long and 200 m wide, and South Page Island is approximately 500 m long and 200 m wide. Apart from small pockets of soil on top of the islands which support scattered plant species, the islands are rocky (Anon 1983). Access via sea transport is difficult and unreliable, necessitating the use of helicopters (Shaughnessy et al. 2013). Given the proximity of these two islands (< 2 km) and the high genetic similarity of Australian sea lion pups born at each island, they are considered one colony (Lowther et al. 2012). Based on maximum pup counts for 14 breeding seasons between 1989 and 2010 (excluding the 1994 breeding season in which pup production was not estimated), there is no significant trend in pup production at this colony; mean pup production is 470 pups per breeding season (Shaughnessy et al. 2013). Unlike Seal Bay and Dangerous Reef, there is no apparent seasonal pattern to pup mortality at The Pages Islands which averages 17 % per breeding season (range 3–56 %; Shaughnessy et al. 2013). Additional methods of estimating pup production have not been reported for The Pages Islands. Given the variation in the timing and frequency of surveys at this colony and the limitation that direct pup counts are likely to underestimate the number of both live and dead pups, the accuracy of the reported pup production and mortality values is uncertain (Shaughnessy et al. 2013).

1.2.2 Threats and knowledge gaps

The fundamental reasons underlying the apparent lack of recovery of Australian sea lion populations are not well understood. The state of knowledge regarding the role of natural and anthropogenic factors in shaping the demography of the Australian sea lion was recently reviewed and priorities for research to address key knowledge gaps that are considered critical to informing the conservation management of this species were identified (Goldsworthy et al. 2009a; Australian Government 2013a and 2013b).

Firstly, given the supra-annual breeding cycle of this species, an inherently slower rate of population recovery than annually breeding species is to be expected. In addition, the high degree of foraging- and female-natal-site fidelity limits dispersal and reduces the likelihood of recolonisation of previous colonies (Campbell et al. 2008a; Lowther et al. 2012). As such, it is critical to assess and manage each colony as effectively closed subpopulations; the numerous small breeding populations of the Australian sea lion poses additional conservation management challenges as they are at increased risk of extinction from stochastic processes and anthropogenic impacts (Goldsworthy et al. 2009a).

The role of inter-specific competition for food resources and nutritional stress on the demography of Australian sea lions is uncertain. At broad spatial scales, there is considerable overlap between foraging areas of the Australian sea lion and long-nosed fur seal, however, long-nosed fur seals are predominantly epipelagic foragers and niche overlap is considered likely to be low (Goldsworthy et al. 2009a). On the other hand, Australian fur seals are benthic foragers and may compete directly for resources with Australian sea lions (Page et al. 2005; Peters et al. 2014). The contemporary expansion and dispersal of Australian fur seal populations into South Australian waters could have implications for the foraging success and survival of sympatric Australian sea lions; however, further investigation is necessary to determine the extent and impact of

competition for mutually targeted prey species (Shaughnessy et al. 2010; Australian Government 2013b).

Factors driving mortality are considered the most likely to significantly inhibit population growth or cause a decline in population size (Goldsworthy et al. 2009a). The role of predation, anthropogenic impacts, and disease are considered here in more detail. Predation has been noted to significantly impact some pinniped populations by reducing demographic recruitment and causing the removal of reproductively active females (Lucas and Stobo 2000; Springer et al. 2003). Great white sharks (*Carcharodon carcharias*) are known to predate on Australian sea lions, with attacks on adult females and juveniles noted most frequently (Shaughnessy et al. 2007), whereas killer whales (*Orcinus orca*) are also suspected to hunt pinnipeds in Australian waters (Goldsworthy et al. 2009a). However, the extent of successful predation on Australian sea lions is unknown and their demographic impact has not been quantified.

Anthropogenic factors may significantly impact pinniped populations by increasing mortality directly, as well as indirectly by affecting foraging and reproductive success (Goldsworthy et al. 2009a). The most important anthropogenic factor impacting Australian sea lion populations is interaction with fisheries, specifically mortality related to fishery bycatch and entanglement in marine debris (Goldsworthy et al. 2009a; Australian Government 2013a and 2013b). Foraging areas of Australian sea lions extensively overlap with areas targeted by gillnet and lobster fisheries; these activities are associated with high levels of bycatch mortality, predominantly of adult females and juveniles, respectively (Campbell et al. 2008b; Hamer et al. 2013a). Marine debris causing entanglement originates primarily from these fisheries and impacts all age classes, although pups are most frequently entangled (Page et al. 2004). Circumstantial evidence of the impact of gillnet fishing is provided by the observation that the major period of increase in pup

production at Dangerous Reef (occurring 2000–2006) was associated with substantial decreases in fishing effort in Spencer Gulf (Goldsworthy et al. 2007). In addition, population viability analyses demonstrated that the observed rates of bycatch were highly likely to lead to effective extinction of most subpopulations within 100 breeding cycles, equivalent to approximately 150 years (Goldsworthy and Page 2007; Campbell et al. 2008b; Goldsworthy et al. 2010b; Hamer et al. 2013a). In order to attempt to reduce the occurrence of gillnet bycatch mortality, the Australian Fisheries Management Authority implemented three primary management interventions in 2011: (1) observer coverage (human or camera) on gillnet fishing vessels was increased to 100 % to more accurately record the occurrence of bycatch; (2) areas up to 20.7 km around breeding colonies were closed to fishing; and (3) ‘trigger-limits’ were introduced such that if bycatch limits are exceeded within designated zones then that zone is closed to fishing for 18 months (Hamer et al. 2013a). In addition, the introduction of sea lion exclusion devices to lobster pots can reduce sea lion mortality without significantly impacting lobster catch rate (Campbell et al. 2008b). The effect of these management interventions on Australian sea lion populations are yet to be thoroughly assessed. In addition, the impact of other anthropogenic factors, such as human disturbance (e.g. tourism) and toxicants, on the recovery of Australian sea lion populations is uncertain and requires further investigation (Goldsworthy et al. 2009a; Australian Government 2013a and 2013b).

Finally, the impact of disease on Australian sea lion health and population demography is unknown. Infectious disease plays an important role in the health and population dynamics of many free-ranging species (Smith et al. 2009; Thompson et al. 2010); the occurrence and impact of infectious diseases are mediated by the dynamic interaction of host, pathogen, and environment factors (Irvine 2006). Endemic and epidemic infectious diseases are associated with significant pup mortality and population

regulation of several pinniped species (Kennedy et al. 2000; Kuiken et al. 2006; Castinel et al. 2007b; Spraker and Lander 2010; Lyons et al. 2011b; Seguel et al. 2013b; Spraker et al. 2014) and a plethora of pathogens have been reported from pinnipeds (Dailey and Brownell 1972; Higgins 2000; Kennedy-Stoskopf 2001; Barnes et al. 2008). However, only limited data is available for the range of infectious disease agents in the Australian sea lion (Table 1) and few studies have investigated the pathogenic effects of these agents; whether infectious disease contributes towards the high rate and oscillating pattern of pup mortality in this species is a key knowledge gap (Goldsworthy et al. 2009a; Australian Government 2013a and 2013b; McIntosh and Kennedy 2013). In particular, given the association of hookworm infection with disease and mortality of pups in several otariid species (Lyons et al. 2001; Chilvers et al. 2009; DeLong et al. 2009; Seguel et al. 2011), and preliminary findings that *Uncinaria* sp. are similarly pathogenic in Australian sea lion pups (R. Gray, pers. comm.), it is imperative to obtain a thorough understanding of hookworm infection in this host.

Table 1 List of infectious disease agents reported in the Australian sea lion

Pathogen	Age class infected	Notes	Reference
Bacteria			
<i>Brucella</i> spp.	Not reported	Serological evidence only Free-ranging individuals	(Dawson 2005)
<i>Helicobacter</i> spp.	Adult	Captive individuals	(Oxley and McKay 2004; Oxley et al. 2004)
<i>Mycobacterium pinnipedii</i>	Subadult, adult	Captive and free-ranging individuals	(Forshaw and Phelps 1991; Cousins et al. 1993)
Fungi			
<i>Microsporium gypseum</i>	Adult	Captive individuals	(Phillips et al. 1986)
Parasites			
<u>Acanthocephala</u>			
<i>Corynosoma australe</i>	Not reported	Free-ranging individuals Likely requires an intermediate host	(Johnston 1937; Smales 1986)
<i>Corynosoma</i> sp.	Not reported	Free-ranging individuals Likely requires an intermediate host	(Smales 1986)
<u>Acarina</u>			
<i>Orthohalarachne attenuata</i>	All	Free-ranging individuals	(Domrow 1974; Marlow 1975; Nicholson and Fanning 1981)
<i>Orthohalarachne diminuata</i>	All	Free-ranging individuals	(Nicholson and Fanning 1981)
<u>Anoplura</u>			
<i>Antarctophthirus microchir</i>	All	Free-ranging individuals	(Dailey and Brownell 1972; Marlow 1975; McIntosh and Murray 2007)
<u>Cestoda</u>			
<i>Adenocephalus pacificus</i> (syn. <i>Diphyllobothrium arctocephalinum</i>)	Not reported	Free-ranging individuals Likely requires an intermediate host	(Johnston 1937; Dailey and Brownell 1972; Hernández-Orts et al. 2015)
<u>Nematoda</u>			
<i>Contracaecum osculatum</i>	Not reported	Free-ranging individuals Likely requires an intermediate host	(Johnston 1937; Johnston and Mawson 1941)
<i>Parafilaroides</i> sp.	Juvenile, adult	Free-ranging individuals Likely requires an intermediate host	(Nicholson and Fanning 1981; Lynch 1999)
<i>Uncinaria</i> sp.	Neonatal	Free-ranging individuals	(Beveridge 1980; Ladds 2009)

(Continued)

Table 1 List of infectious disease agents reported in the Australian sea lion (continued)

Pathogen	Age class infected	Notes	Reference
<u>Protozoa</u>			
<i>Giardia duodenalis</i>	Not reported	PCR detection only Captive and free-ranging individuals	(Delpont et al. 2014)
<i>Toxoplasma gondii</i>	Neonatal, adult	Captive-born neonate; free-ranging adult	(Fay 1989; Kabay 1996)
<u>Trematoda</u>			
<i>Mesostephanus neophocae</i>	Not reported	Free-ranging individuals Likely requires an intermediate host	(Dubois and Angel 1976)
Viruses			
None reported			

1.3 Hookworm infection in pinnipeds

1.3.1 Taxonomy

Hookworms of the genus *Uncinaria* Frölich, 1789 (Nematoda: Ancylostomatidae) are haematophagous parasitic nematodes of the small intestine. Thirteen species are recognised in carnivores (Carnivora) and three additional species are recognised in rodents (Rodentia), tenrecs (Afrosoricida), and treeshrews (Scandentia) – see Table 2. The validity of several additional species has been disputed as a result of unproven host specificity and the questionable significance of some morphological differences (Ransom 1924; Baylis 1933; Olsen 1968; Beveridge 1980); the potential for host-induced effects on parasite morphology engenders caution when deciding whether we have new species (George-Nascimento et al. 1992; Pérez-Ponce de León and Nadler 2010). One of the long-standing parasitological uncertainties is the number of distinct *Uncinaria* species parasitising pinnipeds (George-Nascimento et al. 1992; Nadler et al. 2000). Hookworms (*Uncinaria* spp.) have been reported from eleven otariid and five phocid hosts, but have not been reported from odobenids (Dailey 2001; Brock et al. 2013; Nadler et al. 2013). *Uncinaria lucasi* from the northern fur seal (*Callorhinus ursinus*) was the first hookworm species to be described and named in pinnipeds (Stiles and Hassall 1899; Stiles 1901; redescribed by Baylis 1947), followed by *Uncinaria hamiltoni* from the South American sea lion (*Otaria byronia*) (Baylis 1933). Morphological differences between specimens of each species were sufficient to clearly delineate two separate species, however, the limitations of morphological examination are evidenced by the taxonomic uncertainty which arose from specimens demonstrating ‘intermediate’ or similar morphology to the two named congeners (Baylis 1933; Johnston and Mawson 1945; Baylis 1947; Olsen 1952, cited in Lyons 2005; Botto and Mañé-Garzón 1975; George-Nascimento et al. 1992; Norman 1994; Sepúlveda 1998; Beveridge 2002; Berón-Vera et al. 2004; Castinel et al. 2006). Accurately

distinguishing between *Uncinaria* spp. is not an esoteric pursuit; knowledge of species identity is essential for understanding host-parasite-environment relationships, which is critical for informing the conservation management of parasites and their hosts (Thompson et al. 2010).

Table 2 List of recognised *Uncinaria* species^a

Type host	Parasite species
Carnivora	
<i>Nausa narica</i> and <i>Procyon cancrivorus</i>	<i>Uncinaria bidens</i> (Molin, 1861)
<i>Canis lupus</i>	<i>Uncinaria stenocephala</i> (Railliet, 1884)
<i>Callorhinus ursinus</i>	<i>Uncinaria lucasi</i> Stiles, 1901
<i>Otaria byronia</i>	<i>Uncinaria hamiltoni</i> Baylis, 1933
<i>Prionailurus bengalensis</i>	<i>Uncinaria felidis</i> Maplestone, 1939
<i>Martes zibellina</i>	<i>Uncinaria skrjabini</i> Machul'skii, 1949
<i>Ailurus fulgens</i>	<i>Uncinaria thapari</i> Biocca et Bronzini, 1953
<i>Ursus americanus</i>	<i>Uncinaria yukonensis</i> (Wolfgang, 1956)
<i>Mellivora capensis</i>	<i>Uncinaria parvibursata</i> Le Roux et Biocca, 1957
<i>Ursus americanus</i> and <i>Ursus arctos</i>	<i>Uncinaria rauschi</i> Olsen, 1968
<i>Prionailurus iriomotensis</i>	<i>Uncinaria maya</i> Hasegawa, 1989
<i>Neophoca cinerea</i>	<i>Uncinaria sanguinis</i> Marcus, Higgins, Šlapeta et Gray, 2014 ^b
<i>Zalophus californianus</i>	<i>Uncinaria lyonsi</i> Kuzmina et Kuzmin, 2015 ^c
Rodentia	
<i>Hydromys chrysogaster</i>	<i>Uncinaria hydromyidis</i> Beveridge, 1980
Afrosoricida	
<i>Tenrec ecaudatus</i>	<i>Uncinaria bauchoti</i> Chabaud, Brygoo et Tchérakoff, 1964
Scandentia	
<i>Tupaia glis</i>	<i>Uncinaria olseni</i> Chabaud et Durette-Desset, 1975

^a Note, this list includes two hookworm species from pinnipeds which were described subsequent to the commencement of this study.

^b See Chapter 2.

^c *Uncinaria lyonsi* is referred to as “*Uncinaria* species A” in Chapter 2, the publication of which pre-dated this species description.

Molecular techniques coupled with traditional morphological analysis can reduce the uncertainty of species delimitation and description, facilitating species identification (Pérez-Ponce de León and Nadler 2010). Using this combined approach, the existence of considerable species diversity within pinniped hookworms has been recently demonstrated (Nadler et al. 2000; Lyons et al. 2011a; Nadler et al. 2013; Ramos et al. 2013). In addition,

Nadler et al. (2013) demonstrated reduced host specificity, showing that *U. lucasi* also parasitises Steller sea lions (*Eumetopias jubatus*) and that *U. hamiltoni* also parasitises South American fur seals (*Arctophoca australis*). These findings indicate that the significant morphometric differences observed within different host-associated populations of *U. lucasi* (Olsen 1952, cited in Lyons 2005; Nadler et al. 2013) and *U. hamiltoni* (George-Nascimento et al. 1992) could be due to host-induced effects on parasite morphology; however, these morphological differences could also be accounted for by age-dependent variation.

In Australian waters, hookworms from the Australian sea lion, Australian fur seal, and long-nosed fur seal are traditionally considered closely related and morphologically similar to *U. hamiltoni* (Norman 1994; Ramos et al. 2013). Ramos et al. (2013) demonstrated that *Uncinaria* spp. from Australian pinnipeds are molecularly distinct from North American pinniped hookworms and that the Australian sea lion and long-nosed fur seal may share a single species of *Uncinaria*. However, the species diversity, global phylogenetic relationships, and taxonomic identity of hookworms from these hosts are unresolved.

1.3.2 Epidemiology

The life cycle of pinniped-associated hookworms has been most extensively investigated for *U. lucasi* in the northern fur seal in Alaska (Olsen 1958; Olsen and Lyons 1965; Lyons et al. 2011b). A key feature of the life cycle is the transmammary transmission of infective third-stage hookworm larvae to pups during the immediate post-parturient period (Olsen and Lyons 1965). This route of hookworm infection is also supported by studies in the Juan Fernandez fur seal (*Arctophoca philippii philippi*), California sea lion (*Zalophus californianus*), and New Zealand sea lion (*Phocarctos*

hookeri) (Sepúlveda and Alcaíno 1993; Lyons et al. 2003; Castinel et al. 2007a). Hookworm larvae are likely only transmitted to pups for a short period of time post-parturition as generally little intra-host variation is observed in the size of hookworms (Olsen and Lyons 1965). Infective third-stage larvae develop to fourth-stage larvae approximately 24 hours after ingestion, with the final moult to fifth-stage (adult) hookworms occurring 4–5 days after ingestion (Lyons 1994); as the duration of the prepatent period is approximately 12–15 days, it is possible that hookworm could have pathogenic effects on their host prior to an infection being diagnosed by the presence of eggs in host faeces (Olsen and Lyons 1965). The duration of patent hookworm infection varies among host species, being approximately 6–8 weeks in northern fur seal pups (Lyons et al. 2011b) and 6–8 months in South American fur seal, South American sea lion, and California sea lion pups (Lyons et al. 2000a; Hernández-Orts et al. 2012; Katz et al. 2012), whilst New Zealand sea lion pups are infected for at least 2–3 months (Castinel et al. 2007a). Free-living third-stage hookworm larvae can hatch from eggs passed in faeces within approximately 4 days, although development may be delayed for up to several months in the environment (Olsen and Lyons 1965; Lyons et al. 1997; Castinel et al. 2007a). Sandy substrate rather than rocky terrain is considered favourable for the development, survival, and transmission of free-living hookworm larvae (Lyons et al. 2000b; Castinel et al. 2007a) which infect hosts either orally or percutaneously, and then migrate through the tissues, predominantly to the ventral abdominal blubber, where they remain dormant as tissue-stage larvae until late pregnancy or lactation (Olsen and Lyons 1965). The longevity of tissue-stage hookworm larvae has been observed to be at least 6 and 16 years in captive, non-regularly breeding northern fur seal and California sea lion adult females, respectively (Twisleton-Wykeham-Fiennes 1966; Lyons and Keyes 1984). Unlike in human and canine hosts, maturation of tissue-stage larvae to adult hookworms

has not been observed, but could potentially occur as patent infection of older age classes has been reported at 1–22 % prevalence (Olsen 1958; George-Nascimento et al. 1992; Lyons et al. 2012b). For this reason, adult males are referred to as dead-end hosts with respect to infection in pups (Lyons et al. 2011b), but could have a potential role in parasite dispersal (Haynes et al. 2014). This life cycle is considered typical for hookworms in otariids (Lyons et al. 2005), however, the validity of extrapolating between parasitic species and hosts is uncertain.

The primary factors hypothesised to influence the prevalence and intensity of hookworm infection in pinnipeds are the type of colony substrate and host density (Lyons et al. 2012b). Greater hookworm infection intensity and prevalence have been associated with sandy substrates over rocky substrates, presumably due to enhanced survival of free-living larvae (Sepúlveda 1998; Lyons et al. 2000b; Lyons et al. 2005; Ramos 2013), and host behavioural preferences for substrate-type interacts with host density to affect individual exposure to free-living larvae (Lyons et al. 2005; Lyons et al. 2012b). However, the relative importance of these environment and host factors in the epidemiology of hookworm infection in the Australian sea lion are unknown. Key knowledge gaps for this host are the prevalence and intensity of hookworm infection, whether transmammary transmission plays a central role in infection of neonatal pups, and the timing of hookworm life cycle events. In addition, it has been hypothesised that colony-specific seasonal differences in the survival and transmission of hookworm larvae could result in fluctuations in the impact of hookworm infection for pups, contributing towards the seasonal patterns of pup mortality observed at Seal Bay and Dangerous Reef (Goldsworthy et al. 2009b).

1.3.3 Clinical impact

Hookworm infection is associated with anaemia, reduced growth rates, and mortality of pups in several otariid species (Lyons et al. 2001; Chilvers et al. 2009; DeLong et al. 2009; Seguel et al. 2011). In addition, hookworm infection may also increase individual susceptibility to other disease processes such as bacterial infection or trauma (Castinel et al. 2007b; Spraker et al. 2007). The primary mechanism by which hookworms cause disease is by feeding-associated damage to the intestinal mucosa and submucosa, resulting in gastrointestinal blood loss and eliciting local and systemic inflammatory responses (Loukas and Prociv 2001; Hotez et al. 2004). The major factor implicated in the severity of hookworm-associated disease is the intensity of hookworm infection. Studies in northern fur seals indicate that infection intensities greater than 100 hookworms are associated with haemorrhagic enteritis and anaemia (Olsen 1958; Keyes 1965). In addition, relatively high hookworm infection intensity is associated with pup mortality in the New Zealand sea lion (mean intensity of 824 hookworms per pup – Castinel et al. 2007a), South American fur seal (range 120–200 – Seguel et al. 2013a), northern fur seal (means 643, 1200 – Lyons et al. 1997; Mizuno 1997), and California sea lion (means 612, 1284 – Lyons et al. 1997; Lyons et al. 2001), whereas comparatively low hookworm infection intensity was not associated with pup mortality in the Australian fur seal (range 2–18 – Ramos 2013), Juan Fernandez fur seal (mean 17 – Sepúlveda 1998), and South American sea lion (means 38, 135 – Berón-Vera et al. 2004; Hernández-Orts et al. 2012). Interestingly, higher hookworm infection intensity has been positively associated with body condition in northern fur seal, California sea lion, and Juan Fernandez fur seal pups found dead; pups in better body condition demonstrated higher hookworm infection intensity compared to pups in poor body condition (Lyons et al. 1997; Sepúlveda 1998; Lyons et al. 2001; Lyons et al. 2005). Lyons et al. (2005) hypothesised that higher

hookworm infection intensity and better body condition is related to greater milk intake. In contrast, increased growth rates were observed in New Zealand sea lion and northern fur seal pups following anthelmintic administration to reduce hookworm infection intensity (Chilvers et al. 2009; DeLong et al. 2009). One possible explanation that accounts for these observations is that the pups in better body condition which were found dead were relatively younger and experiencing the effects of acute rather than chronic hookworm infection, and therefore adverse effects on body condition were not yet evident. Further investigation of the relationship between hookworm infection intensity and clinical impact is required; however, methods for determining hookworm infection intensity in live pups have not been validated, confounding investigation.

Neonatal anaemia is observed to occur in many pinniped species, however, despite the widespread host distribution of hookworms (and other haematophagous parasites such as lice; Leonardi and Palma 2013), this anaemia has generally been attributed to a physiological host-response to the increased oxygen availability compared to the environment *in utero* and the expansion of plasma volume with pup growth (Richmond et al. 2005; Clark et al. 2007; Trillmich et al. 2008). Evidence that hookworm infection causes anaemia in neonatal pinnipeds is relatively limited (Olsen 1958; Lyons et al. 2001) and there are no reports that characterise neonatal anaemia in pinnipeds by the presence or absence of reticulocytosis; classifying the erythroid response to anaemia as regenerative or non-regenerative in this way is fundamental to differentiating between pathological and physiological mechanisms (Stockham and Scott 2008). In addition, although haematological reference intervals have been developed for pups of several pinniped species to facilitate health assessment, and several studies have associated host and environment factors with changes in the values of haematological parameters (Bryden and Lim 1969; Geraci 1971; Lane et al. 1972; Banish and Gilmartin 1988; Castellini et al.

1993; Castellini et al. 1996; Horning and Trillmich 1997; Hall 1998; Rea et al. 1998; Sepúlveda et al. 1999; Trumble and Castellini 2002; Lander et al. 2003; Richmond et al. 2005; Boily et al. 2006; Clark et al. 2007; Trillmich et al. 2008; Greig et al. 2010; Brock et al. 2013; Lander et al. 2014), few studies have considered the effects of parasitosis on the haematological values of pups and their implications for the assessment of health status.

The clinical impact of hookworm infection on the health status of Australian sea lion pups has not been reported and is considered a key knowledge gap for understanding the impediments to population recovery in this species (Goldsworthy et al. 2009a; Australian Government 2013a and 2013b); determining the clinical impact of hookworm infection in pups is critical to informing conservation management to mitigate the risks of population extinction. Haematological analysis is a reasonably non-invasive and efficient tool used as part of routine health assessment, permitting repeated *in situ* sampling of live individuals with minimal impact on animal welfare and survival (Clark 2004; Wimsatt et al. 2005). Changes in haematological values provide quantifiable measures of the impact of, and host-response to, disease. However, inherent host-specific differences and dynamic temporospatial adaptations to physiological stressors also influence haematological characteristics (Gray et al. 2005; Beldomenico et al. 2008; Hufschmid et al. 2014); although haematological reference intervals for free-ranging Australian sea lions older than six months of age have been reported (Needham et al. 1980; Fowler et al. 2007b), data from neonatal pups is lacking. For this reason, the establishment of species- and context-specific reference intervals are necessary to define and assess deviations from baseline health status (Sergent et al. 2004; Ceriotti et al. 2009). This would also facilitate the implementation of long-term health surveillance, which is critical for both the early recognition of emerging disease and to inform species conservation management (Hall et al. 2007; Thompson et al. 2010).

1.3.4 Management

The aim of parasite control in free-ranging wildlife populations within the context of conservation management is not to eradicate parasitic infection, but rather to lessen the impact of associated disease on the health and survival of host-individuals to improve population viability; parasites are integral components of biodiverse ecosystems and should also be conserved (Gómez and Nichols 2013). Fundamentally, the benefits of parasite control to the host species and their ecosystem must outweigh the potential ecological and evolutionary costs associated with the loss or reduction of the targeted parasite and any collateral consequences (Stringer and Linklater 2014). Critically, there must be a recognised need for parasite control; as the impact of parasitic infection on the host population's viability increases, so does the impetus to intervene (Stringer and Linklater 2014).

Disruption of the hookworm life cycle in free-ranging pinnipeds to prevent or reduce the effects of hookworm infection and improve pup survival has been investigated using several approaches. The first control recommendations were aimed at reducing the exposure of northern fur seals to free-living hookworm larvae by removing the sandy colony substrate and preventing access to sandy areas with fences, in addition to modifying the environment with boulders to provide pups with a degree of protection from conspecific trauma (Jordan et al. 1898); the extent to which these recommendations were adopted is not clear. Olsen (1958) later investigated the utility of environmental larvicides to reduce the number of larvae present in the substrate and identified cresylic acid as an effective treatment. However, no reduction in pup mortality was observed in the breeding season following large-scale environmental application, although the cause of death for these pups and the intensity of hookworm infection were not determined (Olsen 1958).

Anthelmintic administration to prevent or eliminate hookworm infection in northern fur seal pups has been investigated using several compounds. Orally administered dichlorvos was found to be highly effective (> 99 %), although apparent organophosphate toxicity was observed in some pups (Lyons et al. 1978; Bigg and Lyons 1981). Subcutaneously administered disophenol demonstrated variable effectiveness (< 1–100 %) and was associated with diarrhoea in some pups (Lyons et al. 1978; Lyons et al. 1980). The effectiveness of diethylcarbamazine, fenbendazole, levamisole, and morantel tartrate have also been investigated, although few details are available (Kolevatova et al. 1998, cited in Lyons et al. 2011b). Possibly the most successful treatment to date, subcutaneously administered ivermectin was found to be highly effective (~ 96–100 %) at eliminating or preventing hookworm infection in both northern fur seal and New Zealand sea lion pups and no significant adverse effects on pup health were identified (Beekman 1984; Castinel et al. 2007a; Chilvers et al. 2009; DeLong et al. 2009). Of these anthelmintics, the host-benefits associated with treatment have only been reported for northern fur seal pups administered ivermectin at approximately 2 weeks of age (DeLong et al. 2009) and New Zealand sea lion pups administered ivermectin at 3, 7, and 30 days of age (Chilvers et al. 2009). For both species, treated pups demonstrated significantly higher growth rates relative to untreated controls (Chilvers et al. 2009; DeLong et al. 2009). Ivermectin treated northern fur seal pups also demonstrated significantly higher short-term survival rates than controls (DeLong et al. 2009), whereas treated New Zealand sea lion pups only demonstrated a trend towards higher rates of survival than controls during a high mortality event associated with *Klebsiella pneumoniae* infection (Chilvers et al. 2009). Haematological changes associated with anthelmintic administration in pinniped pups have only been reported from a small study of New Zealand sea lion pups in which significant

haematological changes were not associated with ivermectin treatment to prevent hookworm infection (Castinel 2007).

For free-ranging neonatal Australian sea lion pups, hookworm infection is hypothesised to cause significant health impacts, evident by anaemia, systemic inflammatory responses, and reduced growth rates, as well as to contribute directly and indirectly towards increased pup mortality. Experimental manipulation of the host-parasite relationship via anthelmintic administration is required to test these hypothesised causal relationships and quantify the impact of hookworm infection, both of which are necessary to inform conservation management on the effectiveness of, and need for, control strategies (Irvine 2006; Stringer and Linklater 2014). In addition, it is critical to prospectively assess the utility of anthelmintic administration in this species to reduce pup mortality should, for example, the need for sporadic parasite control occur, as demonstrated for New Zealand sea lion pups during high mortality epizootics associated with *K. pneumoniae* infection (Chilvers et al. 2009).

1.4 Aims of the thesis

The life history of the Australian sea lion offers a unique comparative system to investigate the role of host, pathogen, and environment factors in influencing the epidemiology and clinical impact of hookworm infection in neonatal pinnipeds. This study was undertaken primarily at Seal Bay and Dangerous Reef due to their disparate biogeographical features, opposite seasonal patterns of variation in pup mortality, their status as major breeding colonies for this species, and the opportunity to minimise colony disturbance and impact on individual animals by collaborating with other researchers undertaking concurrent field investigations. This study investigates the overarching hypothesis that hookworm infection is a significant cause of disease and mortality in

Australian sea lion pups by addressing some of the key knowledge gaps pertaining to the taxonomy, epidemiology, and clinical impact of hookworm infection in this species. In addition, the utility of anthelmintic treatment as a tool for the conservation management of this endangered species is investigated. The aims of this thesis were to:

1. Determine the number of hookworm species parasitising the Australian sea lion (Chapter 2);
2. Resolve the taxonomic identity and phylogenetic relationships of hookworms from the Australian sea lion (Chapter 2);
3. Determine the utility of quantitative morphometrics to delineate *Uncinaria* species by investigating intra- and inter-host parasite morphometric variation and the effect of host age on parasite morphometrics (Chapter 2);
4. Investigate whether transmammary transmission plays a central role in hookworm infection in the Australian sea lion and determine the timing of key hookworm life cycle events (Chapters 2 and 3);
5. Determine the prevalence and intensity of hookworm infection in free-ranging Australian sea lion pups and investigate the role of host, pathogen, and environment factors in the epidemiology of infection in this host (Chapter 3);
6. Relate the prevalence and intensity of hookworm infection in Australian sea lion pups to seasonal fluctuations in the magnitude of colony pup mortality (Chapter 3);
7. Develop haematological reference intervals for free-ranging neonatal Australian sea lion pups within the context of endemic hookworm infection to facilitate health assessment (Chapter 4);
8. Characterise the erythroid response to anaemia in Australian sea lion pups to differentiate between pathological and physiological mechanisms (Chapter 4);

9. Determine the clinical impact of hookworm infection in neonatal Australian sea lion pups (Chapters 4 and 5);
10. Investigate the effectiveness of ivermectin administration to eliminate hookworm infection in Australian sea lion pups and test the hypotheses that hookworm infection causes anaemia, systemic inflammatory responses, and reduced growth rates, and contributes towards increased pup mortality (Chapter 5).

Chapter 2





Uncinaria sanguinis sp. n. (Nematoda:
Ancylostomatidae) from the endangered Australian
sea lion, *Neophoca cinerea* (Carnivora: Otariidae)

Author contribution statement

This chapter was published by the Institute of Parasitology, Biology Centre of the Academy of Sciences of the Czech Republic as:

Marcus AD, Higgins DP, Šlapeta J, Gray R (2014) *Uncinaria sanguinis* sp. n. (Nematoda: Ancylostomatidae) from the endangered Australian sea lion, *Neophoca cinerea* (Carnivora: Otariidae). *Folia Parasitol* 61:255–265. doi:10.14411/fp.2014.037

Alan Marcus was the primary author of this publication and contributed towards all aspects including the study design, sample collection and analysis, and writing of the manuscript. Rachael Gray, Damien Higgins, and Jan Šlapeta contributed towards the study design, interpretation of findings, and critical revision of the manuscript. Rachael Gray and Damien Higgins also contributed towards sample collection. Jan Šlapeta also contributed towards the phylogenetic analyses and the line drawings.

Alan D. Marcus		Date	<u>2/6/2015</u>
Damien P. Higgins		Date	<u>4/6/2015</u>
Jan Šlapeta		Date	<u>2/6/2015</u>
Rachael Gray		Date	<u>2/6/2015</u>

Uncinaria sanguinis sp. n. (Nematoda: Ancylostomatidae) from the endangered Australian sea lion, *Neophoca cinerea* (Carnivora: Otariidae)

Alan D. Marcus, Damien P. Higgins, Jan Šlapeta and Rachael Gray

Faculty of Veterinary Science, The University of Sydney, Sydney, New South Wales, Australia

Abstract: This study investigates the identity of hookworms parasitising the Australian sea lion, *Neophoca cinerea* (Péron), from three colonies in South Australia, Australia. The Australian sea lion is at risk of extinction because its population is small and genetically fragmented. Using morphological and molecular techniques, we describe a single novel species, *Uncinaria sanguinis* sp. n. (Nematoda: Ancylostomatidae). The new species is most similar to hookworms also parasitic in otariid hosts, *Uncinaria lucasi* Stiles, 1901 and *Uncinaria hamiltoni* Baylis, 1933. Comparative morphometrics offered limited utility for distinguishing between species within this genus whilst morphological features and differences in nuclear ribosomal DNA sequences delineated *U. sanguinis* sp. n. from named congeners. Male specimens of *U. sanguinis* sp. n. differ from *U. lucasi* and *U. hamiltoni* by relatively shorter anterolateral and externodorsal rays, respectively, and from other congeners by the relative lengths and angulations of bursal rays, and in the shape of the spicules. Female specimens of *U. sanguinis* sp. n. are differentiated from *Uncinaria* spp. parasitic in terrestrial mammals by differences in vulval anatomy and the larger size of their eggs, although are morphologically indistinguishable from *U. lucasi* and *U. hamiltoni*. Molecular techniques clearly delimited *U. sanguinis* sp. n. as a distinct novel species. Obtaining baseline data on the parasites of wildlife hosts is important for the investigation of disease and the effective implementation and monitoring of conservation management.

Keywords: new species, hookworms, conservation, phylogeny, pinnipeds

This article contains supporting information (Tables S1, S2) online at <http://folia.paru.cas.cz/suppl/2014-3-255.pdf>

Hookworms of the genus *Uncinaria* Frölich, 1789 (Nematoda: Ancylostomatidae) are haematophagous parasitic nematodes of the small intestine. Eleven species have been described in carnivores (Mammalia: Carnivora) and three additional species described in rodents (Rodentia), tenrecs (Afrosoricida) and treeshrews (Scandentia). The validity of several species has been disputed as a result of unproven host specificity and the questionable significance of some morphological differences (Ransom 1924, Baylis 1933, Olsen 1968, Beveridge 1980). Molecular techniques coupled with morphological analysis can reduce the uncertainty of species delimitation and description (Pérez-Ponce de León and Nadler 2010). Baseline knowledge of species identity has significant implications for the management of parasitic diseases and conservation of the host themselves (Thompson et al. 2010).

One of the long-standing parasitological uncertainties is the number of distinct *Uncinaria* species parasitising pinnipeds (Carnivora) (George-Nascimento et al. 1992, Nadler et al. 2000). Parasites in the genus *Uncinaria* have been reported from eleven otariid (eared seals) and

five phocid (earless seals) hosts (Dailey 2001, Lyons et al. 2011a, Brock et al. 2013, Nadler et al. 2013). Only two species have been described and named, *Uncinaria lucasi* Stiles, 1901 from the northern fur seal, *Callorhinus ursinus* (Linnaeus), and *Uncinaria hamiltoni* Baylis, 1933 from the South American sea lion, *Otaria byronia* de Blainville; syn. *Otaria flavescens* (Shaw). However, the existence of greater species diversity has been recently recognised using molecular techniques (Nadler et al. 2000, Lyons et al. 2011b, Nadler et al. 2013, Ramos et al. 2013). Additionally, Nadler et al. (2013) demonstrated reduced host-specificity, showing that *U. lucasi* also parasitises Steller sea lion, *Eumetopias jubatus* (Schreber), and *U. hamiltoni* also parasitises the South American fur seal, *Arctophoca australis* (Zimmerman). The taxonomic identity of specimens from other pinniped hosts is unresolved.

In Australian waters, hookworms from the Australian sea lion, *Neophoca cinerea* (Péron), Australian fur seal, *Arctocephalus pusillus doriferus* (Wood Jones), and New Zealand fur seal, *Arctophoca australis forsteri* (Lesson), are traditionally considered closely related and morpho-

logically similar to *U. hamiltoni* (Norman 1994, Ramos et al. 2013). Ramos et al. (2013) showed that *Uncinaria* spp. from Australian pinnipeds are molecularly distinct from North American pinniped hookworms and that the Australian sea lion and New Zealand fur seal may share a single species of *Uncinaria*.

The aim of the present study was to address whether a single novel species of hookworm parasitises the Australian sea lion. The Australian sea lion is classified as endangered in the IUCN Red List of Threatened Species due to its small, genetically fragmented population, population declines at some colonies, and the risk of extinction from fishery by-catch (Goldsworthy and Gales 2008, McIntosh et al. 2012). We investigated the utility of quantitative morphometrics to delineate *Uncinaria* species by assessing intra- and inter-host parasite variation and determining the effect of host age on parasite morphometrics. Subsequently, we used molecular techniques to examine the phylogenetic relationships of *Uncinaria* species. The outcome is a description of a new *Uncinaria* species.

MATERIALS AND METHODS

Sample collection

All samples were collected from Australian sea lion pups. Necropsies were undertaken on pups found dead at Seal Bay, Kangaroo Island (n = 84), Dangerous Reef, Spencer Gulf (n = 32), and South Page Island, Backstairs Passage (n = 1), in South Australia during 2009–2013 as a part of ongoing investigations into the pathogenesis and epidemiology of hookworm infection in the Australian sea lion. A sample of hookworm specimens was collected from the small intestine from fresh carcasses or from frozen-thawed pups and stored in 70% ethanol at -20 °C; the remainder of the intestinal content was stored in 10% neutral buffered formalin. Daily observations of marked and unmarked pups at Seal Bay in 2012 facilitated the collection of hookworm specimens from dead pups of known-age (8–101 days, n = 12). All samples were collected under Government of South Australia Department of Environment, Water and Natural Resources Wildlife Ethics Committee approvals (3–2008 and 3–2011) and Scientific Research Permits (A25008/4–8).

Morphological study

Individual hookworms were examined in temporary glass slide mounts using 4, 10, 20, and 40× objectives of an Olympus BX60 microscope equipped with differential interference contrast (Olympus, Sydney, Australia) and photographed with a ProgRes CFscan camera (Jenoptik, Jena, Germany) or DP80 camera (Olympus). Voucher specimens preserved with 70% ethanol were cleared and mounted with lactophenol (Rep 1963). Hookworm vouchers used for molecular studies were mounted in 70% ethanol. Measurements recorded with an ocular micrometer were body length, maximum body width (measured at approximately mid-specimen), buccal capsule length, buccal capsule width, teeth height, oesophageal length, and maximum oesophageal width. Additional measurements recorded from male specimens included spicule length and gubernaculum length, and from female specimens the distance from the vulva to tail tip, tail length, and the average length and width of three

eggs per female. Measurements for each feature were not obtained for every specimen due to differences in preservation or clarity. Additional morphological observations were performed with specimens cleared and mounted in glycerol. Specimens obtained from pups with hookworm eggs in their faeces were considered mature, confirmed by the presence of eggs in female hookworms. Measurements given in-text are mean with standard deviation, followed in parentheses by the range and sample size. Values in brackets are measurements for the holotype male or allotype female, as indicated. All measurements are in micrometres, unless otherwise stated.

Z-stack images were created using cellSens Dimensions 1.8.1 (Olympus). All images were imported into Adobe Photoshop CS6 (Adobe Systems, San Jose, USA) and multiple images were combined to illustrate features spanning greater than a single field-of-view. Images were converted to greyscale and adjustment layers for levels and brightness/contrast were used to optimise the appearance of investigated features. Individual specimens were isolated from the background using layer masks and presented on a white background. Line drawings accompany photomicrographs to illustrate characteristic features. The introduction of the new hookworm species name followed generic rules for describing a new (parasite) species (Šlapeta 2013).

Statistical analysis

Descriptive statistics were used to assess the intra- and inter-host morphometric differences between hookworm specimens. The effect of host age on the body length of both male and female hookworms, and on spicule length for male specimens, was assessed with a linear fixed effects model using REML in GenStat 16.1 (VSN International, Hemel Hempstead, UK). Model assumptions were checked by visually assessing the fitted-value plots of residuals for homogeneity of variance and the histograms of residuals for approximately normal distributions. Predicted means were compared using Fisher's Protected LSD ($\alpha = 0.05$). We focused on these features as they may be objectively measured, are unlikely to be substantially influenced by specimen preparation, and are considered important for species discrimination (Baylis 1933, Rep 1963, Nadler et al. 2000).

Morphological identification

The identification of examined specimens was attempted using taxonomic keys and species descriptions (Baylis 1933, 1947, Maplestone 1939, Chabaud et al. 1964, Olsen 1968, Chabaud and Durette-Desset 1975, Beveridge 1980, Hasegawa 1989, Lichtenfels 2009, Willmott and Chabaud 2009).

Molecular characterisation

An approximately 4 mm mid-body section was excised aseptically using a sterile scalpel blade from individual hookworms collected from Seal Bay (n = 10; 10 hosts), Dangerous Reef (n = 10; 8 hosts) and South Page Island (n = 1). The anterior and posterior ends were retained as voucher specimens. The mid-section of each hookworm was air dried prior to DNA extraction. DNA was extracted from mid-body sections using the standard protocol of the Isolate II Genomic DNA Kit (Bioline, Sydney, Australia).

Two regions of nuclear ribosomal DNA (rDNA) encompassing the internal transcribed spacers (ITS1 and ITS2) and a partial sequence of the 28S rDNA were amplified by PCR using primers No. 93/No. 94 and No. 527/No. 532, respectively (Nadler et al. 2000). PCR was performed using 15 µl MyTaq Red Mix (Bioline), 5 pmol of each primer, and 2 µl template DNA in

a total volume of 30 µl. Cycling parameters consisted of an initial denaturation at 94 °C for 5 min, followed by 30 or 35 cycles of 94 °C for 15 s, 54 °C for 15 s, 72 °C for 15 s, and a final extension at 72 °C for 2 min. Sequence polymorphism was verified by PCR with an alternate polymerase master mix, EconoTaq PLUS GREEN (Lucigen, Middleton, USA), using the same parameters described above. Successful amplification was confirmed by gel electrophoresis using a 1.5% agarose gel with GelRed (Biotium, Hayward, USA). Amplicons were bidirectionally sequenced using PCR primers at Macrogen Inc. (Seoul, South Korea). Sequences were assembled and analysed with CLC Main Workbench 6.8.1 (CLC bio, Aarhus, Denmark).

Obtained sequences were aligned with hookworm sequences from the otariid hosts Australian fur seal (ITS: HE962177; 28S rDNA: HQ261929), New Zealand fur seal (ITS region only: HE962175), New Zealand sea lion, *Phocarctos hookeri* (Gray) (HQ262095; HQ261983), South American sea lion (HQ262119; HQ262006), South American fur seal (HQ262102; HQ261989), Steller sea lion (HQ262131; HQ262018), northern fur seal (AF217890; AF257730), and California sea lion, *Zalophus californianus* (Lesson) (AF217889; AF257724), and from the phocid hosts southern elephant seal, *Mirounga leonina* (Linnaeus) (HE962181; HQ262009), and Mediterranean monk seal, *Monachus monachus* Hermann (HQ262065; HQ261951). An Australian sea lion hookworm sequence (ITS region only: HE962176), collected from Dangerous Reef in 1994 (Ramos et al. 2013), was included for historical comparison. *Uncinaria stenocephala* Railliet, 1884 (AF194145; AF257712) from the Arctic fox, *Alopex lagopus* (Linnaeus), and *Uncinaria felidis* Maplestone, 1939 (Shimono et al. 2012; ITS2 only) from the Tsushima leopard cat, *Prionailurus bengalensis euptilura* (Elliott), were included for outgroup comparisons. The numbering of sequence residues is according to rDNA unit of *Caenorhabditis elegans* (Maupas, 1900) (X03680).

Multiple sequence alignment was constructed using ClustalW 1.83 (Thompson et al. 1994). Comparisons were performed for the ITS1, ITS2 and 28S rDNA regions to determine percentage sequence similarity (uncorrected p-distance) using CLC Main Workbench. Phylogenetic analyses were performed using a concatenated DNA dataset. The best-fit model of DNA evolution was selected based on the lowest Bayesian Information Criterion using MEGA 5.2.1 (Tamura et al. 2011). Bayesian trees were constructed using MrBayes 3.2.2 (Ronquist et al. 2012). The parameters were set to Kimura-2 parameter model and run for 2 000 000 generations with sampling every 200 generations with four chains (temperature set to 0.2). The analysis was run beyond convergence and run multiple times.

The consensus tree was constructed and posterior probabilities calculated from the dataset from which the first 500 000 generations were discarded. Maximum Parsimony and Maximum Likelihood trees were calculated using MEGA 5.2.1 (Tamura et al. 2011). The Maximum Parsimony tree was obtained using the Subtree-Pruning-Regrafting algorithm with search level 1 in which the initial trees were obtained by the random addition of sequences (10 replicates). The initial Maximum Likelihood search was started from a tree reconstructed using the Neighbour-Joining method with distances estimated using the Maximum Composite Likelihood approach. Bootstrap support was calculated from 1000 replicates. A schematic tree of the phylogeny demonstrating character state changes was constructed from the majority consensus of the three phylogenetic analyses.

RESULTS

Morphological and molecular data of nematodes recovered from the Australian sea lion have revealed an undescribed hookworm species. Our current investigation forms the basis for a formal description of a new parasite species belonging to the genus *Uncinaria*.

Uncinaria sanguinis sp. n.

Figs. 1–14

Description: Small, translucent, white nematodes with occasional dark-red intestinal contents. Sexual dimorphism evident in mature specimens (Figs. 1, 2). Anterior extremity bent dorsally (Figs. 4, 6). Ventricose-shaped oral opening armed with paired anterior and posterior cutting plates (Figs. 3–6). Four small submedian papillae present around oral opening (Fig. 5), amphids not observed. Buccal capsule large and globular with continuous walls. Dorsal gutter present. Bilateral teeth with variably shaped tips arise ventrally, anterior to the annular thickening of buccal capsule. Oesophagus elongate, posteriorly clavate. Paired lateral deirids, small, present in mid-oesophageal region (Fig. 6). Nerve ring in mid-oesophageal region (Fig. 6). Excretory pore opens ventrally, in mid-oesophageal region (Fig. 6).

Male (description based on 116 specimens; for detailed morphometric data – see Tables 1, 2): Total body length 9.1 ± 1.7 (3.8–11.5; 46) [8.8] mm; juvenile (8–14 days) 7.2 ± 1.7 (3.8–8.9; 9) mm, mature (15–39 days) 10.1 ± 1.0 (8.5–11.5; 15) mm. Maximum body width 390 ± 67 (165–470; 46) [400]. Buccal capsule length 239 ± 21 (163–280; 37) [260], width 216 ± 21 (175–270; 37) [270]. Teeth height 45.4 ± 11.7 (25–80; 20) [60]. Oesophageal length 965 ± 126 (650–1 275; 33) [900], width 169 ± 32 (70–220; 33) [170]. Copulatory bursa symmetrical with single dorsal lobe, paired lateral and ventral lobes (Figs. 10, 11). Paired lateroventral prebursal papillae, small, anterior to copulatory bursa. Dorsal ray bifurcates distally with each short stem terminating in 3 digitations. Externodorsal ray arises proximally from dorsal ray, does not reach edge of lateral lobe. Lateral rays in contact proximally, separated for distal half; anterolateral ray shorter than other lateral rays; mediolateral and posterolateral rays approximately equal in size, tips reach edge of lateral lobe. Lateroventral and ventroventral rays equal in length and fused, tips reach edge of ventral lobe. Gubernaculum elongate, posteriorly clavate; length 104 ± 22 (50–150; 24) [105]. Paired spicules, length 762 ± 47 (660–860; 34) [670]; juvenile (8–14 days) 748 ± 51 (660–800; 6), mature (15–39 days) 733 ± 39 (670–800; 8). Spicules feature transverse striations and sharp tips. Genital cone prominent with long, thin, bilaterally paired papillae present near posterior margin.

Female (description based on 112 specimens; for detailed morphometric data – see Tables 1, 2): Total body length 13.5 ± 3.5 (4.5–20.2; 52) [13.3] mm; juvenile (8–14 days) 8.9 ± 1.8 (5.3–11.0; 7) mm, mature

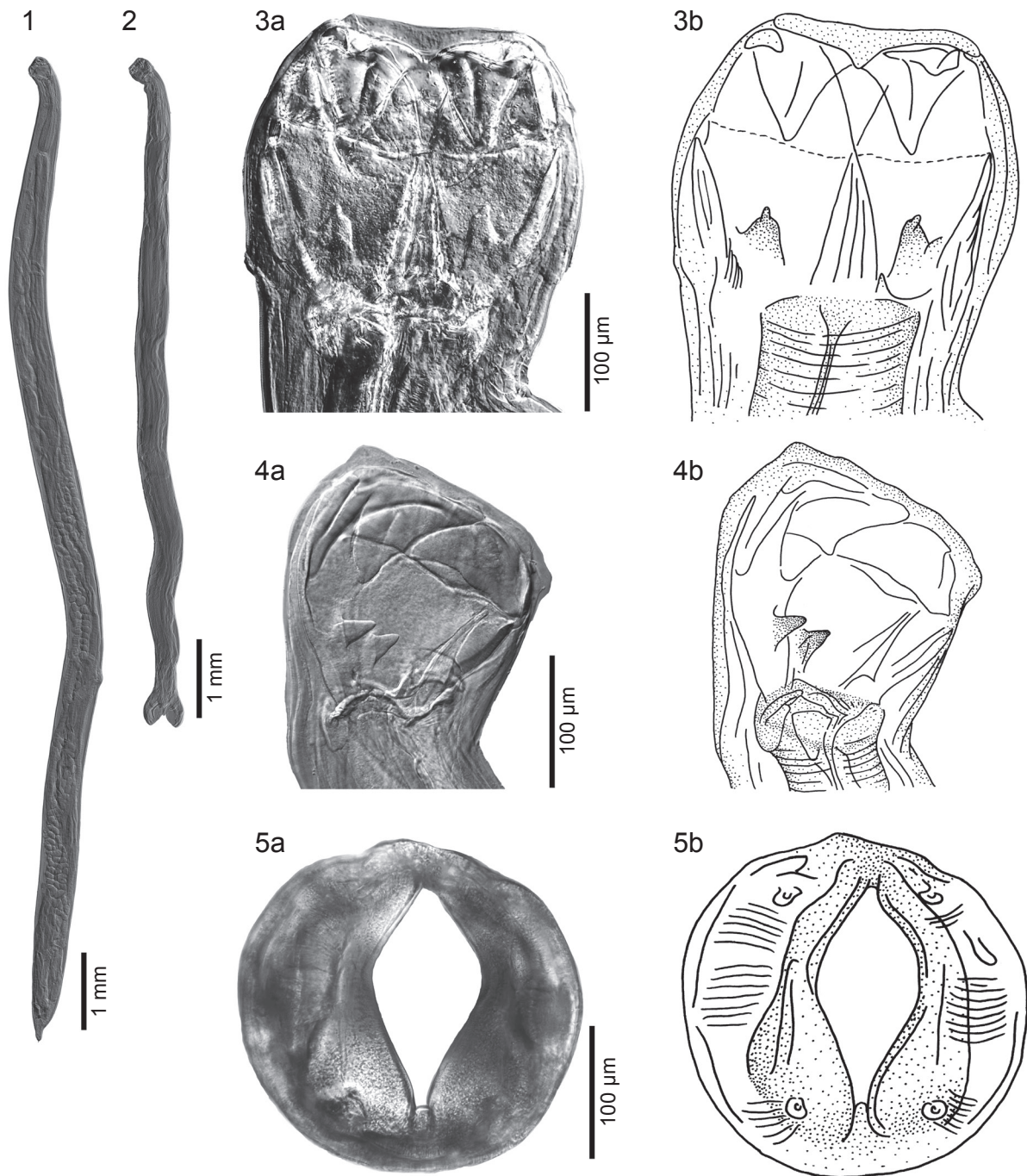

Figs. 1–5. Photomicrographs (a) and line drawings (b) of *Uncinaria sanguinis* sp. n. from Australian sea lion (*Neophoca cinerea*). **Fig. 1.** Allotype female. **Fig. 2.** Holotype male. **Fig. 3.** Holotype male, buccal capsule, dorsoventral view. **Fig. 4.** Juvenile male, buccal capsule, oblique lateral view. **Fig. 5.** Female, buccal capsule, en face view.

(15–101 days) 15.0 ± 1.7 (12.4–18.5; 17) mm. Maximum body width 451 ± 90 (110–590; 52) [520]. Buccal capsule length 287 ± 31 (200–330; 25) [300], width 257 ± 24 (185–300; 25) [265]. Teeth height 54 ± 12 (38–75; 17) [75]. Oesophageal length 1059 ± 130 (750–1275; 25) [1000], width 183 ± 37 (90–240; 25) [170]. Tail bluntly conical, length 204 ± 39 (150–285; 27) [225], terminating with a short spike (Fig. 8). Vulva located in middle to

posterior third of body, 5.2 ± 1.6 (1.8–9.8; 29) [5.0] mm to posterior end; prominent anterior and posterior vulval lips (Fig. 7). Ovejectors longitudinal; uterine eggs thin shelled, elliptical, $124 \pm 6 \times 81 \pm 9$ (110–135 \times 55–95; 19) [123 \times 80] (Fig. 9).

Type host: Australian sea lion, *Neophoca cinerea* (Péron), emaciated and freshly deceased pup, female, 15 days old, 6 kg, collected 1 May 2012 (ID SBDP12–088).

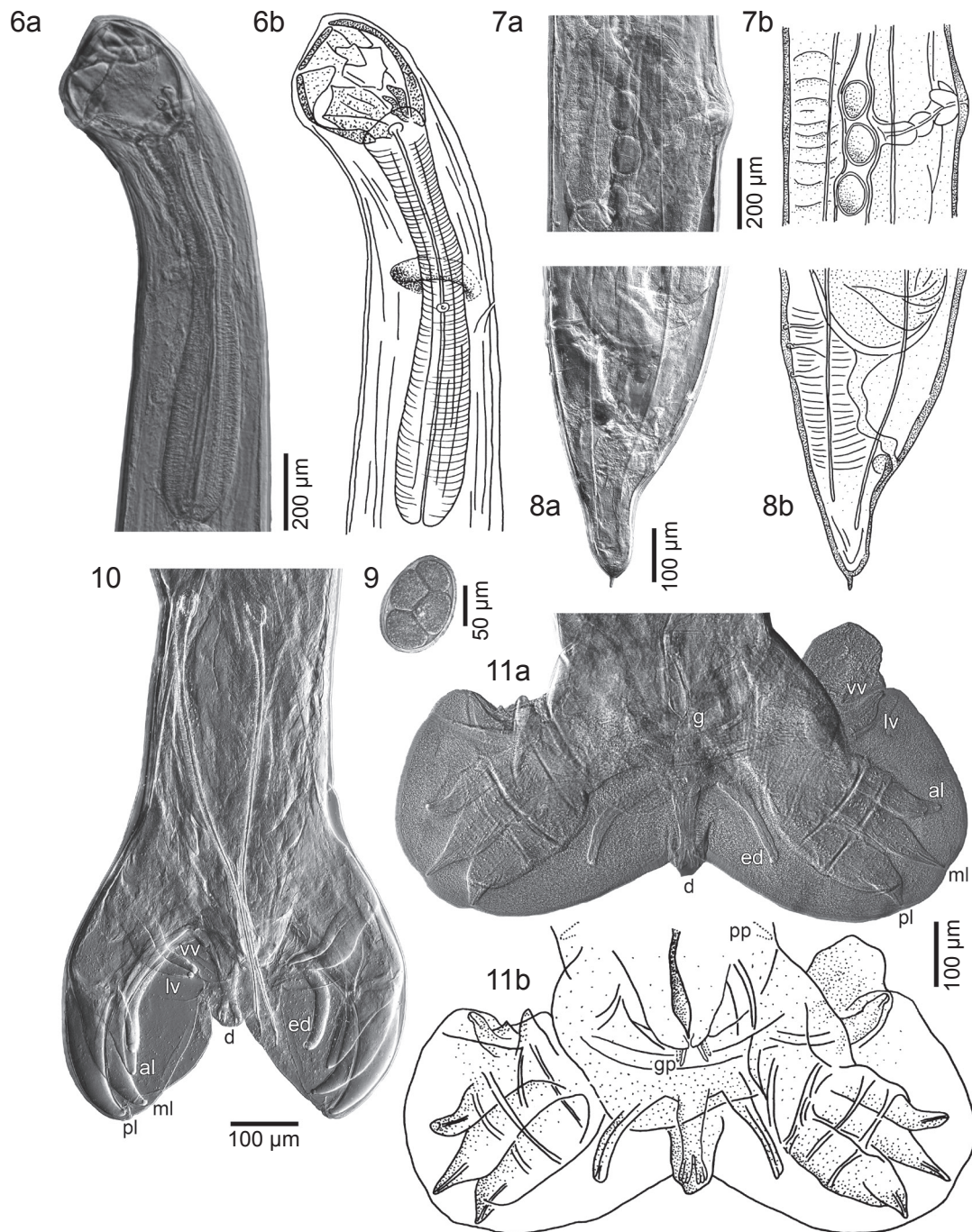

Figs. 6–11. Photomicrographs (a) and line drawings (b) of *Uncinaria sanguinis* sp. n. from Australian sea lion (*Neophoca cinerea*). **Fig. 6.** Allotype female, anterior end, lateral view. **Fig. 7.** Allotype female, vulva, lateral view. **Fig. 8.** Allotype female, tail with mucron, lateral view. **Fig. 9.** Ovum. **Fig. 10.** Holotype male, copulatory bursa and spicules, dorsoventral view. **Fig. 11.** Male, copulatory bursa and gubernaculum, dorsoventral view with rays spread. *Abbreviations:* al – anterolateral; d – dorsal; ed – externodorsal; g – gubernaculum; gp – genital cone papillae; lv – lateroventral; ml – mediolateral; pl – posterolateral; pp – prebursal papillae; vv – ventroventral.

Type locality: Seal Bay (35°59'37"S; 137°18'29"E), Kangaroo Island, South Australia, Australia.

Other localities: Seal Bay, Kangaroo Island (35°59'40"S; 137°19'00"E), Dangerous Reef, Spencer Gulf (34°48'54"S; 136°12'43"E), and South Page Island, Backstairs Passage (35°46'37"S; 138°17'31"E); South Australia, Australia.

Site of infection: Based on necropsy, adult and juvenile worms in large numbers in the small intestine of Australian sea lion pups. Unembryonated eggs released into the environment with faeces.

Type specimens: Holotype male (AHC 35806), allotype female (AHC 35807), and 58 paratypes (AHC 35808 and

Table 1. Measurements of *Uncinaria sanguinis* sp. n. collected from Australian sea lion (*Neophoca cinerea*) pups.

Location	DR	SPI	Seal Bay	Seal Bay	DR	SPI	Seal Bay	Seal Bay
Sex		Mature ♀		Juvenile ♀		Mature ♂		Juvenile ♂
Max. sample size	17	1	24	10	14	1	20	11
Hosts examined	10	1	13	7	8	1	10	6
Body length	10.2–20.2 (6.0)	16.9	10.1–18.7 (4.0)	4.5–11 (2.2)	6.6–11.4 (1.4)	10.1	8.5–11.5 (2.0)	3.8–8.9 (3.8)
Body width	450–590 (100)	540	320–580 (140)	110–380 (10)	350–450 (50)	460	350–470 (50)	165–380 (85)
Buccal capsule length	250–330 (30)	-	255–320 (15)	200–275 (-)	220–265 (15)	220	215–280 (50)	163–250 (50)
Buccal capsule width	235–300 (50)	-	225–300 (10)	185–275 (-)	175–225 (35)	190	190–270 (40)	180–250 (25)
Teeth height	40–75 (15)	-	50–75 (-)	38–60 (-)	35–50 (15)	-	40–80 (35)	25–45 (-)
Oesophageal length	1000–1150 (40)	-	1000–1275 (125)	750–1000 (-)	850–1050 (150)	1025	900–1275 (25)	650–900 (100)
Oesophageal width	120–230 (50)	-	170–240 (0)	90–195 (-)	125–195 (55)	165	160–220 (35)	70–180 (50)
Tail length	160–285 (35)	245	150–275 (95)	150–235 (-)	-	-	-	-
Vulva to posterior end	3.5–9.8 (0.9)	7.0	4.6–7.4 (1.9)	1.8–4.1 (-)	-	-	-	-
Average egg length	110–128 (15)	-	115–135 (8)	-	-	-	-	-
Average egg width	73–95 (7)	-	55–88 (33)	-	-	-	-	-
Gubernaculum length	-	-	-	-	50–100 (50)	-	90–150 (45)	75–125 (50)
Spicule length	-	-	-	-	680–850 (110)	760	670–860 (60)	660–800 (110)

Measurements are given in mm for body length and vulva to posterior end. All other measurements are in μm . Reported values are minimum–maximum. Values in parentheses are the maximum range observed within individual hosts. *Abbreviations:* DR – Dangerous Reef; SPI – South Page Island.

Table 2. Comparative measurements (mean \pm standard deviation) of body and spicule lengths for *Uncinaria sanguinis* sp. n. collected from Australian sea lion (*Neophoca cinerea*) pups of known age.

Pup age (days)	Body length (mm)				Spicule length (μm)		
	n	♀	n	♂	n	♂	
Juvenile	8	1	5.25 ^a	3	5.48 ^a \pm 1.89	2	790 \pm 14
	11	2	9.70 ^b \pm 0.42	2	8.12 ^b \pm 0.18	-	-
	12	2	8.75 ^b \pm 0.35	2	8.25 ^b \pm 0.00	2	740 \pm 28
	14	2	9.90 ^b \pm 1.56	2	7.94 ^b \pm 1.33	2	715 \pm 78
Mature	15	4	13.18 ^c \pm 0.64	4	9.12 ^{bc} \pm 1.01	2	735 \pm 92
	27	4	16.38 ^d \pm 1.49	3	10.52 ^c \pm 0.96	2	735 \pm 21
	29	3	14.33 ^{ce} \pm 0.26	4	9.95 ^{bc} \pm 0.77	3	723 \pm 25
	37	2	14.88 ^{de} \pm 1.77	2	10.62 ^c \pm 0.53	-	-
	39	2	16.38 ^{de} \pm 0.53	2	11.00 ^c \pm 0.35	1	750
	101	2	15.75 ^{de} \pm 2.83	-	-	-	-

For each sex, means that do not share a superscript letter (a–e) are significantly different ($P < 0.05$).

AHC 46823–46850) deposited in the Australian Helminthological Collection of the South Australian Museum, Adelaide, Australia. Additional paratypes deposited in the U.S. National Parasite Collection, Maryland, USA (USNPC 107521–107522; $n = 20$), Natural History Museum, London, UK (NHMUK 2013.11.13.1–2013.11.13.20; $n = 20$), and Helminthological Collection of the Institute of Parasitology, České Budějovice, Czech Republic (IPCAS N–1047; $n = 2$).

DNA sequences (GenBank accession numbers): Partial 28S rDNA: KF690639–KF690649; ITS1, 5.8S rDNA, ITS2: KF690650–KF690670.

Etymology: The species epithet reflects the haemorrhage and effective exsanguination caused by large burdens of this parasite in the type host. The name is derived as Latin singular genitive.

Morphometrical variation. Measurements were obtained for examined features with inter-host morphometrical variation being greater than intra-host variation (Ta-

ble 1). Ranges of all morphometrical features overlapped for mature hookworms from Seal Bay, Dangerous Reef and South Page Island. Juvenile hookworms, collected from pups at Seal Bay with prepatent infections, differed from mature specimens by the absence of eggs in females and generally reduced magnitude for morphometrical values, however, no functional morphological differences were identified (Fig. 4).

Host age and hookworm sex significantly influenced hookworm body length ($F_{8,29} = 3.89$, $P = 0.003$), with significant sexual dimorphism, associated with maturity, observed from 15 days (females longer than males, $P < 0.05$; Table 2). Whilst body length generally increased with host age and mature females were significantly longer than juvenile females ($P < 0.05$), males at 15 and 29 days were not significantly longer than juvenile males ($P > 0.05$). Additionally, spicule length was not significantly related to host age ($F_{6,7} = 0.49$, $P = 0.796$).

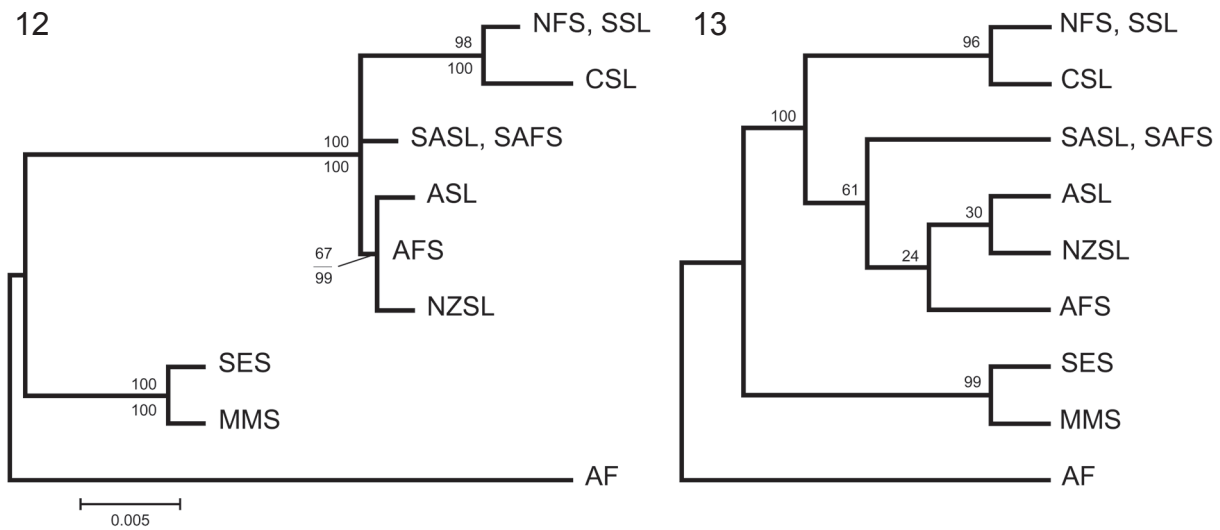

Figs. 12, 13. Phylogenetic relationships of host-associated *Uncinaria* spp. estimated with concatenated ITS1, ITS2, and 28S rDNA sequence data. **Fig. 12.** Maximum Likelihood tree based on the K2 model in MEGA5 with the highest log likelihood (-2117.3390). Numbers above the nodes represent bootstrap values (1000 replicates), values below the branches represent Bayesian posterior probabilities based on the K2 model calculated in MrBayes. The tree is drawn to scale, with branch lengths measured in the number of substitutions per site. **Fig. 13.** The majority consensus rule tree constructed using Maximum Parsimony based on SPR algorithm in MEGA5. Numbers above the nodes represent bootstrap values (1000 replicates). The multiple sequence alignment included nine nucleotide sequences and a total of 1149 positions in the final dataset. **Abbreviations:** AF – Arctic fox, *Alopex lagopus*; AFS – Australian fur seal, *Arctocephalus pusillus doriferus*; ASL – Australian sea lion, *Neophoca cinerea*; CSL – California sea lion, *Zalophus californianus*; MMS – Mediterranean monk seal, *Monachus monachus*; NZSL – New Zealand sea lion, *Phocartos hookeri*; NFS – northern fur seal, *Callorhinus ursinus*; SASL – South American sea lion, *Otaria byronia*; SAFS – South American fur seal, *Arctophoca australis*; SES – southern elephant seal, *Mirounga leonina*; SSL – Steller sea lion, *Eumetopias jubatus*.

DNA sequences. Four DNA markers were amplified. The complete ITS1 of *U. sanguinis* was 364 bp long, ITS2 was 227 bp long and the 5.8S rDNA sequence of *U. sanguinis* was 153 bp long (Seal Bay, n = 10; Dangerous Reef, n = 10; South Page Island, n = 1). The partial 28S rDNA sequence of *U. sanguinis* was 992 bp long (Seal Bay, n = 5; Dangerous Reef, n = 5; South Page Island, n = 1).

Molecular distance analysis. *Uncinaria sanguinis* from Seal Bay, Dangerous Reef and South Page Island demonstrated 100% sequence similarity at ITS1, ITS2, 5.8S rDNA, and 28S rDNA. There was a single polymorphism (C/T) in ITS1 at position 199 in one worm (AHC 46824; KF690651), which was not present in another worm from the same host (AHC 46825; KF690652). The polymorphism was confirmed by sequencing PCR product generated using two different DNA polymerases. The historical Australian sea lion and New Zealand fur seal hookworm ITS sequences (HE962176 and HE962175, respectively) demonstrated 100% similarity to *U. sanguinis* sequences. Additionally, the New Zealand fur seal hookworm ITS sequence (HE962175) demonstrated an ambiguous nucleotide at position 199 in ITS1, corresponding to the polymorphic site in worm AHC 46824 (KF690651). Pairwise comparisons with *Uncinaria* from other otariid, phocid, canid and felid hosts demonstrated high levels of sequence similarities at ITS1 and ITS2 (Table S1). Fewer differences were evident between hookworm species at the 28S rDNA locus; sequence similarity to *U. sanguinis*

was 99.3–99.8% (Table S2). The 5.8s rDNA locus was invariant across all *Uncinaria* species.

Molecular character analysis. Bayesian analysis demonstrated 100% support (posterior probability) for one phocid and three otariid hookworm-clades (Figs. 12, 14). The phocid clade consists of two sequences, representing two putative new species, one each from the southern elephant seal and the Mediterranean monk seal. The otariid clade is further divided into the North and South American clades and the Oceanic clade (Figs. 12, 14). The North American otariid clade contains sequences belonging to *U. lucasi* from the northern fur seal and the Steller sea lion, and sequences belonging to the putative new species *Uncinaria* ‘species A’ *sensu* Nadler et al. (2000) from the California sea lion. The South American otariid clade consists exclusively of sequences belonging to *U. hamiltoni* from the South American sea lion and the South American fur seal. The Oceanic otariid clade consists of sequences belonging to *U. sanguinis* from the Australian sea lion and two sequences from unnamed *Uncinaria* spp. from the New Zealand sea lion and the Australian fur seal, respectively. Hookworms from the New Zealand fur seal are provisionally considered to be *U. sanguinis* sp. n. on the basis of limited data.

Maximum Likelihood and Maximum Parsimony analyses provided 100% bootstrap support for separate phocid and otariid hookworm-clades (Figs. 12–14). The Maximum Likelihood analysis demonstrated 100% support for

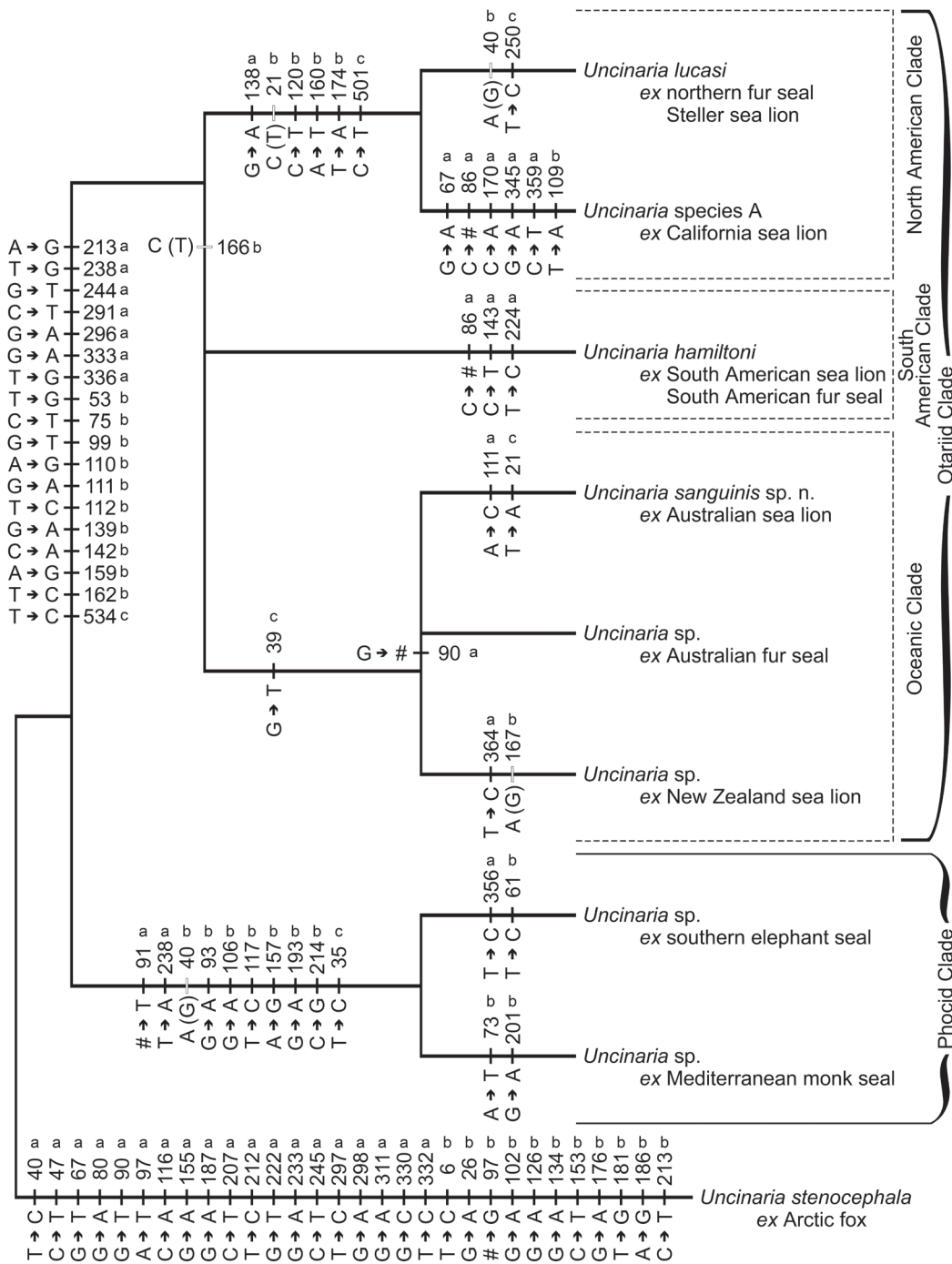

Fig. 14. Schematic of phylogenetic relationships of pinniped *Uncinaria* spp. constructed from the majority consensus of Bayesian inference, Maximum Likelihood and Maximum Parsimony methods with concatenated ITS1, ITS2, and 28S rDNA sequence data. *Uncinaria felidis* and *Uncinaria* sp. from *Arctophoca forsteri* are excluded due to incomplete data. The bars indicate nucleotide character changes with reference to the outgroup *Uncinaria stenocephala*. Homoplasy characters shared with *U. stenocephala* are indicated by white bars with the derived character state at this position indicated in parentheses. Nucleotide gaps are indicated by '#'. Alignment positions are specific to each locus (a – ITS1; b – ITS2; c – 28S rDNA). Four clades are evident, one from phocid hosts and three from otariid hosts.

three otariid hookworm-clades and moderate (67%) support for the three sequence lineages within the Oceanic clade (Fig. 12). The Maximum Parsimony analysis moderately (61%) supported the South American and Oceanic

clades and, in contrast to the other phylogenetic analyses, provided only weak (< 50%) support for separate sequences within the Oceanic clade (Fig. 13). However, fixed rDNA character state changes provide evidence for

independent evolutionary lineages and species delimitation (Fig. 14).

Differential diagnosis. *Uncinaria sanguinis* demonstrates the general morphological characteristics of the Ancylostomatinae and the specific features of the genus *Uncinaria*, including the dorsally directed anterior extremity, a globular buccal capsule with continuous walls, well-developed cutting plates, and a dorsal gutter (Lichtenfels 2009). The species can be differentiated from all other named species in the genus *Uncinaria* on the basis of morphological features and available molecular data. Morphologically, *U. sanguinis* is very similar to the otariid hookworms *U. lucasi* and *U. hamiltoni*, demonstrating subtle morphological differences. An annular thickening of the base of the buccal capsule, observed in *U. sanguinis* and *U. hamiltoni*, was reported absent in the description of *U. lucasi*, but subsequently noted in other specimens (Lyons and DeLong 2005). Male specimens of *U. sanguinis* exhibit shorter anterolateral rays relative to the other lateral rays, a feature shared with *U. hamiltoni*, differentiating these species from *U. lucasi* which exhibits lateral rays of almost equal length (Baylis 1947). The relatively shorter externodorsal rays of *U. sanguinis* distinguish it from *U. hamiltoni* – see Baylis (1933).

Female specimens of *U. sanguinis* are morphologically indistinguishable from *U. lucasi* and *U. hamiltoni*. *Uncinaria sanguinis* is definitively identified and delimited from *U. lucasi* by thirteen fixed character state changes at three loci (ITS1, n = 3; ITS2, n = 6; 28S, n = 4) and from *U. hamiltoni* by seven changes at two loci (ITS1, n = 5; 28S, n = 2).

The size of eggs from *U. sanguinis* is similar to those from *U. lucasi* and *U. hamiltoni*, and is approximately twice the size of eggs from *Uncinaria* spp. parasitic in terrestrial mammals, differentiating female otariid hookworms. The only other native Australian hookworm, *Uncinaria hydromyidis* Beveridge, 1980, described from the Australian water rat, *Hydromys chrysogaster* Geoffroy, a murid host in north-eastern Queensland, may be further distinguished from *U. sanguinis* by its relatively longer ventral and dorsal rays, blunt spicule tips, the absence of the annular buccal capsule thickening, and female specimens feature inconspicuous vulval lips (Beveridge 1980). *Uncinaria bidens* (Molin, 1861), found in procyonids (Carnivora), is differentiated from *U. sanguinis* by relatively longer ventral rays and the angulation of the lateral ray tips (Olsen 1968).

The felid hookworms, *U. felidis* and *Uncinaria maya* Hasegawa, 1989, differ from *U. sanguinis* by their posterolateral, externodorsal and dorsal rays being of equal length and female specimens exhibit prevulvar flaps or protruding anterior lips (Maplestone 1939, Hasegawa 1989). *Uncinaria bauchoti* Chabaud, Brygoo et Tchéprikoff, 1964 and *Uncinaria olsenii* Chabaud et Durette-Desset, 1975, identified from tenrecid (Afrosoricida)

and tupaiid (Scandentia) hosts, respectively, exhibit large deirids and have been considered by some authors (Chabaud et al. 1966, Lichtenfels 2009) to represent a subgenus, *Megadeirides* Chabaud, Bain et Houin, 1966. All other *Uncinaria* species, found in carnivore hosts from the ailurid, canid, mustelid and ursid families, may be morphologically discriminated from *U. sanguinis* and each other on the basis of their lateral rays using Olsen's (1968) key. Molecularly, *U. sanguinis* is delimited from *U. stenocephala* by 54 fixed character state changes at three loci (ITS1, n = 27; ITS2, n = 24; 28S, n = 3) and from *U. felidis* by 32 changes in ITS2.

DISCUSSION

Hookworms collected from Australian sea lions were found to belong to a single novel species, *Uncinaria sanguinis* sp. n. Morphological and molecular investigations did not discriminate between specimens from three South Australian colonies and provided no evidence for the presence of cryptic species or geographical variants. This is the third species within the genus *Uncinaria* to be described and named from otariid hosts and is morphologically most similar to *U. lucasi* and *U. hamiltoni*. Differences in the relative lengths of the bursal rays differentiate these species and fixed rDNA sequence diversity demonstrates independent evolutionary lineages.

The potential for host-induced effects on parasite morphology engenders caution when deciding whether we have new species (George-Nascimento et al. 1992, Pérez-Ponce de León and Nadler 2010). As such, assessing the normal range of morphometric variation within a species is of critical importance for accurate species-description and comparisons. We found little intra-host variation for specimens of *U. sanguinis* from Australian sea lions. Similarly, Olsen and Lyons (1965) reported no variation in the size of *U. lucasi* within individual northern fur seals. These findings support the hypothesis that pinnipeds acquire hookworm infection over a short period of time, likely via the transmammary route shortly after birth (Olsen and Lyons 1965). However, we also observed large morphometric variation between hosts, in part related to host age, highlighting the importance of examining specimens from multiple host-individuals across a range of ages in order to assess the extent of species variation. Interestingly, juvenile hookworms demonstrated no functional morphological differences when compared to adult hookworms and may be associated with host-pathology, which has implications for the detection of disease in live animals.

The wide morphometric ranges we obtained overlap with those of other *Uncinaria* spp., suggesting limited utility for quantitative morphometrics for species discrimination within this genus. Similar conclusions were reached by other authors who identified significant host-associated morphometric differences within *U. hamiltoni*

from the South American sea lion and South American fur seal (George-Nascimento et al. 1992) and within *U. lucasi* from the northern fur seal and Steller sea lion (Olsen 1952, Nadler et al. 2013). Whether these differences were host-induced or due to age-dependent variation is unclear due to limited or unreported host sample sizes and unknown host ages. Regardless, these findings support the need to employ molecular techniques to delimit and describe morphologically-similar species.

Hookworms from the Australian fur seal, New Zealand fur seal, and New Zealand sea lion cluster with *U. sanguinis* within the Oceanic clade. Morphological differences between Oceanic hookworms have not been described although molecular differences delineate two species from the Australian fur seal and New Zealand sea lion, respectively, in addition to *U. sanguinis* from the Australian sea lion. Hookworms from the New Zealand fur seal are thus provisionally considered to be *U. sanguinis*. An alternative viewpoint may be that all hookworms within the Oceanic clade are *U. sanguinis* and that molecular differences reflect intraspecific or geographical variation (Ramos et al. 2013). Whether *U. sanguinis* demonstrates host-specificity or is capable of infecting other hosts remains to be tested. Investigation of hookworm population structure at DNA markers subjected to greater rates of substitution, such as mitochondrial DNA, may demonstrate the level of genetic interchange between colonies and host-associated hookworms and clarify their taxonomic identities further (Gasser and Newton 2000).

Recognising, describing and identifying parasites of free-ranging wildlife species are critical processes for the comprehensive investigation and management of associated disease (Thompson et al. 2010). Delimiting parasitic species is essential for examining host-parasite-environment-anthropogenic interactions, implementing and moni-

toring management programs, and ensuring the conservation of parasites and their hosts. Hookworm infection is a recognised cause of morbidity and mortality in otariid hosts (Castinel et al. 2007, Chilvers et al. 2009, DeLong et al. 2009, Spraker and Lander 2010). In this study, we coupled morphological analysis with molecular techniques to describe and identify a novel species of hookworm in the Australian sea lion. This work contributes towards resolving the taxonomic uncertainty within the genus *Uncinaria* and provides critical data regarding an important pathogen of an endangered mammal. Further investigation and formal identification of the species of hookworms parasitising other pinniped hosts is recommended.

Acknowledgements. We thank the staff at Seal Bay, Department of Environment, Water and Natural Resources for field assistance and the collection of deceased pups, in particular Clarence Kennedy and Janet Simpson; Liisa Ahlstrom, Loreena Butcher, Michael Edwards, Simon Goldsworthy, Claire Higgins, Janet Lackey, Zoe Larum, Theresa Li, Andrew Lowther, Paul Rogers, Laura Schmertmann, Adrian Simon, Ryan Tate, Michael Terkildsen, Mark Whelan, Peter White, Sy Woon, and Mariko Yata for field assistance; Denise McDonnell of The University of Sydney for parasite morphology and laboratory assistance; Benjamin Haynes of The University of Sydney for performing the DNA extractions; Carsten Minten of Olympus Australia for use of equipment and assistance with microphotography; Ian Beveridge of The University of Melbourne for helpful comments on hookworm morphology and presentation; and Glenn Shea of The University of Sydney for assistance with Latin grammar. This work was supported by the Australian Marine Mammal Centre, Department of the Environment, Australian Government (grant number 09/17), Winifred Violet Scott Foundation (2007), and the Whitehead Bequest Conservation 2013, Faculty of Veterinary Science, The University of Sydney. We thank the anonymous reviewers and Tomáš Scholz for their constructive comments on the manuscript.

REFERENCES

- BAYLIS H.A. 1933: A new species of the nematode genus *Uncinaria* from a sea-lion, with some observations on related species. *Parasitology* 25: 308–316.
- BAYLIS H.A. 1947: A redescription of *Uncinaria lucasi* Stiles, a hookworm of seals. *Parasitology* 38: 160–162.
- BEVERIDGE I. 1980: *Uncinaria hydromyidis* sp. n. (Nematoda: Ancylostomatidae) from the Australian water rat, *Hydromys chrysogaster*. *J. Parasitol.* 66: 1027–1031.
- BROCK P.M., HALL A.J., GOODMAN S.J., CRUZ M., ACEVEDO-WHITEHOUSE K. 2013: Applying the tools of ecological immunology to conservation: a test case in the Galapagos sea lion. *Anim. Conserv.* 16: 19–31.
- CASTINEL A., DUIGNAN P.J., POMROY W.E., LOPEZ-VILLALOBOS N., GIBBS N.J., CHILVERS B.L., WILKINSON I.S. 2007: Neonatal mortality in New Zealand sea lions (*Phocarctos hookeri*) at Sandy Bay, Enderby Island, Auckland Islands from 1998 to 2005. *J. Wildl. Dis.* 43: 461–474.
- CHABAUD A.G., BAIN O., HOUIN R. 1966: Nématodes de Potamo-chères malgaches. *Ann. Parasitol.* 41: 599–606.
- CHABAUD A.G., BRYGOO E.R., TCHÉPRAKOFF R. 1964: Nématodes parasites d'insectivores malgaches. *Bull. Mus. Natl. Hist. Nat.* 36: 245–261.
- CHABAUD A.G., DURETTE-DESSSET M.-C. 1975: *Uncinaria (Mega-deirides) olseni* n. sp., Nématode à caractères archaïques parasite d'un *Tupaia* à Bornéo. *Ann. Parasitol. Hum. Comp.* 50: 789–793.
- CHILVERS B.L., DUIGNAN P.J., ROBERTSON B.C., CASTINEL A., WILKINSON I.S. 2009: Effects of hookworms (*Uncinaria* sp.) on the early growth and survival of New Zealand sea lion (*Phocarctos hookeri*) pups. *Polar Biol.* 32: 295–302.
- DAILEY M.D. 2001: Parasitic Diseases. In: L.A. Dierauf and F.M.D. Gulland (Eds.), *CRC Handbook of Marine Mammal Medicine*. Second Edition. CRC Press, Florida, pp. 357–382.
- DELONG R.L., ORR A.J., JENKINSON R.S., LYONS E.T. 2009: Treatment of northern fur seal (*Callorhinus ursinus*) pups with ivermectin reduces hookworm-induced mortality. *Mar. Mamm. Sci.* 25: 944–948.

- GASSER R.B., NEWTON S.E. 2000: Genomic and genetic research on bursate nematodes: significance, implications and prospects. *Int. J. Parasitol.* 30: 509–534.
- GEORGE-NASCIMENTO M., LIMA M., ORTIZ E. 1992: A case of parasite-mediated competition? Phenotypic differentiation among hookworms *Uncinaria* sp. (Nematoda: Ancylostomatidae) in sympatric and allopatric populations of South American sea lions *Otaria byronia*, and fur seals *Arctocephalus australis* (Carnivora: Otariidae). *Mar. Biol.* 112: 527–533.
- GOLDSWORTHY S.D., GALES N. 2008: *Neophoca cinerea*. In: IUCN Red List of Threatened Species. Version 2013.2. World Wide Web electronic publication, www.iucnredlist.org, 01/2014.
- HASEGAWA H. 1989: Two new nematodes from the Iriomote cat, *Prionailurus iriomotensis*, from Okinawa: *Uncinaria (Uncinaria) maya* n. sp. (Ancylostomatoidea) and *Molineus spring-smithi yaveyamanus* n. subsp. (Trichostrongyloidea). *J. Parasitol.* 75: 863–869.
- LICHTENFELS J.R. 2009: Strongylida. In: R.C. Anderson, A.G. Chabaud and S. Willmott (Eds.), *Keys to the Nematode Parasites of Vertebrates: Archival Volume*. CABI, Oxfordshire, pp. 44–68.
- LYONS E.T., DELONG R.L. 2005: Photomicrographic images of some features of *Uncinaria* spp. (Nematoda: Ancylostomatidae) from otariid pinnipeds. *Parasitol. Res.* 95: 346–352.
- LYONS E.T., DELONG R.L., NADLER S.A., LAAKE J.L., ORR A.J., DELONG B.L., PAGAN C. 2011b: Investigations of peritoneal and intestinal infections of adult hookworms (*Uncinaria* spp.) in northern fur seal (*Callorhinus ursinus*) and California sea lion (*Zalophus californianus*) pups on San Miguel Island, California (2003). *Parasitol. Res.* 109: 581–589.
- LYONS E.T., SPRAKER T.R., DELONG R.L., IONITA M., MELIN S.R., NADLER S.A., TOLLIVER S.C. 2011a: Review of research on hookworms (*Uncinaria lucasi* Stiles, 1901) in northern fur seals (*Callorhinus ursinus* Linnaeus, 1758). *Parasitol. Res.* 109: 257–265.
- MAPLESTONE P.A. 1939: A new species of *Uncinaria* Fröhlich, 1789 (Nematoda), with a note on *U. stenocephala* (Railliet, 1884). *Rec. Indian Mus.* 41: 219–222.
- MCINTOSH R.R., GOLDSWORTHY S.D., SHAUGHNESSY P.D., KENNEDY C.W., BURCH P. 2012: Estimating pup production in a mammal with an extended and aseasonal breeding season, the Australian sea lion (*Neophoca cinerea*). *Wildl. Res.* 39: 137–148.
- NADLER S.A., ADAMS B.J., LYONS E.T., DELONG R.L., MELIN S.R. 2000: Molecular and morphometric evidence for separate species of *Uncinaria* (Nematoda: Ancylostomatidae) in California sea lions and northern fur seals: hypothesis testing supplants verification. *J. Parasitol.* 86: 1099–1106.
- NADLER S.A., LYONS E.T., PAGAN C., HYMAN D., LEWIS E.E., BECKMEN K., BELL C.M., CASTINEL A., DELONG R.L., DUGNAN P.J., FARINPOUR C., HUNTINGTON K.B., KUIKEN T., MORGAN D., NAEM S., NORMAN R., PARKER C., RAMOS P., SPRAKER T.R., BERÓN-VERA B. 2013: Molecular systematics of pinniped hookworms (Nematoda: *Uncinaria*): species delimitation, host associations and host-induced morphometric variation. *Int. J. Parasitol.* 43: 1119–1132.
- NORMAN R. 1994: Pathology and ecology of hookworm (*Uncinaria* sp.) infection in a new seal host: the Australian fur seal. In: *Proceedings of the Wildlife Disease Association Annual Conference, Dubbo, 24–25 September 1994*, pp. 29.
- OLSEN O.W. 1952: Report on investigations of hookworms, *Uncinaria lucasi* Stiles, 1901, and hookworm disease of fur seals, *Callorhinus ursinus*, on the Pribilof Islands, Alaska, from 7 July to September 2, 1951. With a supplemental report by W.L. Jellison, ozalid copy. US Department of Interior, Fish and Wildlife Service, Washington, DC. (Cited after Lyons 2005).
- OLSEN O.W. 1968: *Uncinaria rauschi* (Strongyloidea: Nematoda), a new species of hookworms from Alaskan bears. *Can. J. Zool.* 46: 1113–1117.
- OLSEN O.W., LYONS E.T. 1965: Life cycle of *Uncinaria lucasi* Stiles, 1901 (Nematoda: Ancylostomatidae) of fur seals, *Callorhinus ursinus* Linn., on the Pribilof Islands, Alaska. *J. Parasitol.* 51: 689–700.
- PÉREZ-PONCE DE LEÓN G., NADLER S.A. 2010: What we don't recognize can hurt us: a plea for awareness about cryptic species. *J. Parasitol.* 96: 453–464.
- RAMOS P., LYNCH M., HU M., ARNOULD J.P.Y., NORMAN R., BEVERIDGE I. 2013: Morphometric and molecular characterization of the species of *Uncinaria* Fröhlich, 1789 (Nematoda) parasitic in the Australian fur seal *Arctocephalus pusillus doriferus* (Schreber), with notes on hookworms in three other pinniped hosts. *Syst. Parasitol.* 85: 65–78.
- RANSOM B.H. 1924: Hookworms of the genus *Uncinaria* of the dog, fox, and badger. *Proc. U.S. Natl. Mus.* 65: 1–5.
- REP B.H. 1963: On the polyxenidia of the Ancylostomidae and the validity of the characters used for their differentiation. *Trop. Geogr. Med.* 15: 173–218.
- RONQUIST F., TESLENKO M., VAN DER MARK P., AYRES D.L., DARLING A., HÖHNA S., LARGET B., LIU L., SUCHARD M.A., HUELSENBECK J.P. 2012: MrBayes 3.2: efficient Bayesian phylogenetic inference and model choice across a large model space. *Syst. Biol.* 61: 539–542.
- SHIMONO Y., TAHARAGUCHI S., TAIRA K., MIYOSHI N., YASUDA N. 2012: rDNA ITS sequences of *Uncinaria* spp. from Tsushima leopard cat (*Prionailurus bengalensis euptilura*). *Helminthologia* 49: 123–127.
- ŠLAPETA J. 2013: Ten simple rules for describing a new (parasite) species. *Int. J. Parasitol. Parasites Wildl.* 2: 152–154.
- SPRAKER T.R., LANDER M.E. 2010: Causes of mortality in northern fur seals (*Callorhinus ursinus*), St. Paul Island, Pribilof Islands, Alaska, 1986–2006. *J. Wildl. Dis.* 46: 450–473.
- TAMURA K., PETERSON D., PETERSON N., STECHER G., NEI M., KUMAR S. 2011: MEGA5: molecular evolutionary genetics analysis using maximum likelihood, evolutionary distance, and maximum parsimony methods. *Mol. Biol. Evol.* 28: 2731–2739.
- THOMPSON J.D., HIGGINS D.G., GIBSON T.J. 1994: CLUSTAL W: improving the sensitivity of progressive multiple sequence alignment through sequence weighting, position-specific gap penalties and weight matrix choice. *Nucleic. Acids Res.* 22: 4673–4680.
- THOMPSON R.C.A., LYMBERY A.J., SMITH A. 2010: Parasites, emerging disease and wildlife conservation. *Int. J. Parasitol.* 40: 1163–1170.
- WILLMOTT S., CHABAUD A.G. 2009: Glossary and Keys to Subclasses. In: R.C. Anderson, A.G. Chabaud and S. Willmott (Eds.), *Keys to the Nematode Parasites of Vertebrates: Archival Volume*. CABI, Oxfordshire, pp. 1–17.

SUPPORTING INFORMATION

**Marcus et al.: *Uncinaria sanguinis* sp. n. (Nematoda: Ancylostomatidae) from the endangered Australian sea lion, *Neophoca cinerea* (Carnivora: Otariidae).
Folia Parasitologica 61 (3): 255–265.**

Table S1. Pairwise comparisons of the internal transcribed spacer 1 and 2 sequences between host-associated *Uncinaria* spp.

	ASL	NZFS	AFS	NZSL	SASL	SAFS	NFS	SSL	CSL	SES	MMS	AF
ASL		100.00	99.73	99.18	98.63	98.63	99.18	99.18	97.81	96.99	97.27	92.60
NZFS	100.00		99.73	99.18	98.63	98.63	99.18	99.18	97.81	96.99	97.27	92.60
AFS	100.00	100.00		99.45	98.90	98.90	99.45	99.45	98.08	97.27	97.54	92.88
NZSL	99.56	99.56	99.56		98.90	98.90	99.45	99.45	98.08	97.27	97.54	92.60
SASL	100.00	100.00	100.00	99.56		100.00	98.90	98.90	98.08	96.72	96.99	92.05
SAFS	100.00	100.00	100.00	99.56	100.00		98.90	98.90	98.08	96.72	96.99	92.05
NFS	97.36	97.36	97.36	96.92	97.36	97.36		100.00	98.63	97.27	97.54	92.60
SSL	97.36	97.36	97.36	96.92	97.36	97.36	100.00		98.63	97.27	97.54	92.60
CSL	97.36	97.36	97.36	96.92	97.36	97.36	99.12	99.12		95.90	96.17	91.51
SES	91.63	91.63	91.63	91.19	91.63	91.63	90.75	90.75	89.87		99.73	93.99
MMS	90.75	90.75	90.75	90.31	90.75	90.75	89.87	89.87	88.99	98.24		94.26
AF	89.43	89.43	89.43	89.87	89.43	89.43	88.55	88.55	87.67	90.75	89.87	
TLC	85.96	85.96	85.96	86.40	85.96	85.96	85.53	85.53	84.65	86.40	85.53	87.22

Sequence similarity in % for internal transcribed spacer 1 (ITS1, top right triangle) and the internal transcribed spacer 2 (ITS2, bottom left triangle). *Abbreviations:* ASL – Australian sea lion, *Neophoca cinerea*; NZFS – New Zealand fur seal, *Arctophoca australis forsteri*; AFS – Australian fur seal, *Arctocephalus pusillus doriferus*; NZSL – New Zealand sea lion, *Phocartos hookeri*; SASL – South American sea lion, *Otaria byronia*; SAFS – South American fur seal, *Arctophoca australis*; NFS – northern fur seal, *Callorhinus ursinus*; SSL – Steller sea lion, *Eumetopias jubatus*; CSL – California sea lion, *Zalophus californianus*; SES – southern elephant seal, *Mirounga leonina*; MMS – Mediterranean monk seal, *Monachus monachus*; AF – Arctic fox, *Alopex lagopus*; TLC – Tsushima leopard cat, *Prionailurus bengalensis euptilura*.

Table S2. Pairwise comparisons showing sequence similarity at 28S rDNA between host-associated *Uncinaria* spp.

	AFS	NZSL	SASL	SAFS	NFS	SSL	CSL	SES	MMS	AF
ASL	99.82	99.82	99.64	99.64	99.28	99.28	99.46	99.28	99.28	99.46
AFS		100.00	99.82	99.82	99.46	99.46	99.64	99.46	99.46	99.64
NZSL			99.82	99.82	99.46	99.46	99.64	99.46	99.46	99.64
SASL				100.00	99.64	99.64	99.82	99.64	99.64	99.82
SAFS					99.64	99.64	99.82	99.64	99.64	99.82
NFS						100.00	99.82	99.28	99.28	99.46
SSL							99.82	99.28	99.28	99.46
CSL								99.46	99.46	99.64
SES									100.00	99.82
MMS										99.82

Abbreviations: ASL – Australian sea lion, *Neophoca cinerea*; AFS – Australian fur seal, *Arctocephalus pusillus doriferus*; NZSL – New Zealand sea lion, *Phocartos hookeri*; SASL – South American sea lion, *Otaria byronia*; SAFS – South American fur seal, *Arctophoca australis*; NFS – northern fur seal, *Callorhinus ursinus*; SSL – Steller sea lion, *Eumetopias jubatus*; CSL – California sea lion, *Zalophus californianus*; SES – southern elephant seal, *Mirounga leonina*; MMS – Mediterranean monk seal, *Monachus monachus*; AF – Arctic fox, *Alopex lagopus*.

Chapter 3

Epidemiology of hookworm (*Uncinaria sanguinis*)

infection in free-ranging Australian sea lion

(*Neophoca cinerea*) pups



Author contribution statement

This chapter was published by Springer-Verlag Berlin Heidelberg as:

Marcus AD, Higgins DP, Gray R (2014) Epidemiology of hookworm (*Uncinaria sanguinis*) infection in free-ranging Australian sea lion (*Neophoca cinerea*) pups. Parasitol Res 113:3341–3353. doi:10.1007/s00436-014-3997-3

Alan Marcus was the primary author of this publication and contributed towards all aspects including the study design, sample collection and analysis, and writing of the manuscript.

Rachael Gray and Damien Higgins contributed towards the study design, sample collection, interpretation of findings, and critical revision of the manuscript.

Alan D. Marcus		Date	<u>2/6/2015</u>
Damien P. Higgins		Date	<u>4/6/2015</u>
Rachael Gray		Date	<u>2/6/2015</u>

Epidemiology of hookworm (*Uncinaria sanguinis*) infection in free-ranging Australian sea lion (*Neophoca cinerea*) pups

Alan D. Marcus · Damien P. Higgins · Rachael Gray

Received: 2 June 2014 / Accepted: 16 June 2014 / Published online: 24 July 2014
© Springer-Verlag Berlin Heidelberg 2014

Abstract Understanding the fundamental factors influencing the epidemiology of wildlife disease is essential to determining the impact of disease on individual health and population dynamics. The host–pathogen–environment relationship of the endangered Australian sea lion (*Neophoca cinerea*) and the parasitic hookworm, *Uncinaria sanguinis*, was investigated in neonatal pups during summer and winter breeding seasons at two biogeographically disparate colonies in South Australia. The endemic occurrence of hookworm infection in Australian sea lion pups at these sites was 100 % and post-parturient transmammary transmission is likely the predominant route of hookworm infection for pups. The prepatent period for *U. sanguinis* in Australian sea lion pups was determined to be 11–14 days and the duration of infection approximately 2–3 months. The mean hookworm infection intensity in pups found dead was 2138 ± 552 ($n=86$), but a significant relationship between infection intensity and faecal egg count was not identified; infection intensity in live pups could not be estimated from faecal samples. Fluctuations in infection intensity corresponded to oscillations in the magnitude of colony pup mortality, that is, higher infection intensity was significantly associated with higher colony pup mortality and reduced pup body condition. The dynamic interaction between colony, season, and host behaviour is hypothesised to modulate hookworm infection intensity in this species. This study provides a new perspective to understanding the dynamics of otariid hookworm infection and provides evidence that *U. sanguinis* is a significant agent of disease in Australian

sea lion pups and could play a role in population regulation in this species.

Keywords Australian sea lion · *Neophoca cinerea* · Hookworm · *Uncinaria sanguinis* · Epidemiology · Wildlife disease

Introduction

Infectious disease plays an important role in the population dynamics of many free-ranging species (Smith et al. 2009; Thompson et al. 2010). Population regulation by endemic infectious disease is mediated by the dynamic interaction of host–pathogen–environment factors and may have either positive or negative effects (Telfer et al. 2002; Irvine 2006). For example, cowpox virus infection of wood mice (*Apodemus sylvaticus*) and bank voles (*Clethrionomys glareolus*) increases mortality in winter but increases survival in summer by delaying host maturation; the resulting avoidance of the physiological costs of reproduction outweighs the negative effects of infection (Telfer et al. 2005). As the prevalence of cowpox virus is density dependent, infection is hypothesised to significantly influence population dynamics, as does *Trichostrongylus tenuis* infection in red grouse (*Lagopus lagopus scoticus*) (Hudson et al. 1998) and *Ostertagia gruehneri* infection in Svalbard reindeer (*Rangifer tarandus platyrhynchus*) (Albon et al. 2002). Importantly, infectious disease has been implicated in mass mortalities, declines of wildlife populations, and species extinction, with changes to host, pathogen, and environment factors likely precipitating these events by increasing the occurrence and pathogenicity of infectious disease agents (Smith et al. 2009). For this reason, gaining an understanding of the fundamental factors influencing the epidemiology of wildlife disease is essential to determining its impact on individual and population health and

Electronic supplementary material The online version of this article (doi:10.1007/s00436-014-3997-3) contains supplementary material, which is available to authorized users.

A. D. Marcus · D. P. Higgins · R. Gray (✉)
Faculty of Veterinary Science, The University of Sydney, McMaster
Bldg B14, Sydney, New South Wales 2006, Australia
e-mail: rachael.gray@sydney.edu.au

demographic regulation, and to inform conservation management.

Hookworms (*Uncinaria* spp.) are haematophagous parasitic nematodes predominantly of the small intestine. They are associated with anaemia, reduced growth rates, and mortality of pups in several otariid species (Lyons et al. 2001; Chilvers et al. 2009; DeLong et al. 2009; Seguel et al. 2011). A key feature of the life cycle of *Uncinaria lucasi* in the northern fur seal (*Callorhinus ursinus*) is the transmammary transmission of infective third-stage hookworm larvae to pups during the immediate post-parturient period (Olsen and Lyons 1965). This route of hookworm infection is also supported by studies in the Juan Fernandez fur seal (*Arctophoca philippii philippii*), California sea lion (*Zalophus californianus*), and New Zealand sea lion (*Phocarctos hookeri*) (Sepúlveda and Alcaíno 1993; Lyons et al. 2003; Castinel et al. 2007). The duration of patent hookworm infection varies among species, being approximately 6–8 weeks in northern fur seal pups (Lyons et al. 2011) and 6–8 months in South American fur seal (*Arctophoca australis*), South American sea lion (*Otaria byronia*), and California sea lion pups (Lyons et al. 2000a; Hernández-Orts et al. 2012; Katz et al. 2012), whilst New Zealand sea lion pups are infected for at least 2–3 months (Castinel et al. 2007). Free-living third-stage larvae hatch from eggs passed in faeces, infect hosts either orally or percutaneously, and then migrate predominantly to the ventral abdominal blubber where they remain dormant until late pregnancy or lactation (Olsen and Lyons 1965). The longevity of tissue-stage hookworm larvae has been observed to be at least 6 and 16 years in captive non-regularly breeding northern fur seal and California sea lion females, respectively (Twisleton-Wykeham-Fiennes 1966; Lyons and Keyes 1984). Unlike in human and canine hosts, maturation of tissue-stage larvae to adult hookworms has not been observed but could potentially occur as patent infection of older age classes has been reported at 1–22 % prevalence (Olsen 1958; George-Nascimento et al. 1992; Lyons et al. 2012). For this reason, adult males are referred to as dead-end hosts when considering infection in pups but are considered to have potential to play a role in parasite dispersal (Haynes et al. 2013). This life cycle is considered typical for hookworms in otariids (Lyons et al. 2005); however, the validity of extrapolating between parasitic species and hosts is uncertain.

Factors implicated in the epidemiology and disease outcomes of hookworm infection in otariids include colony substrate, host genetics and behaviour, and hookworm species (George-Nascimento et al. 1992; Spraker et al. 2007; Chilvers et al. 2009; Lyons et al. 2011). Greater hookworm infection intensity and prevalence have been associated with sandy substrates over rocky substrates, presumably due to enhanced survival of free-living larvae (Sepúlveda 1998; Lyons et al. 2000b; Lyons et al. 2005; Ramos 2013), and host behavioural preferences for substrate type interacts with host density to

affect individual exposure to free-living larvae (Lyons et al. 2005; Lyons et al. 2012). Studies in northern fur seals indicate that infection intensities greater than 100 hookworms are associated with haemorrhagic enteritis and anaemia (Olsen 1958; Keyes 1965), although methods for determining hookworm infection intensity in live pups have not been validated or employed in other otariid studies. Three species of hookworm have been described and named in otariids—*U. lucasi* from the northern fur seal and Steller sea lion (*Eumetopias jubatus*), *Uncinaria hamiltoni* from the South American sea lion and South American fur seal, and *Uncinaria sanguinis* from the Australian sea lion (*Neophoca cinerea*) (Baylis 1933; Baylis 1947; Nadler et al. 2013; Marcus et al. 2014)—and greater species diversity has been demonstrated in other otariid hosts (Nadler et al. 2013). However, relative pathogenicity of different species has not been determined due to the confounding effects of differential host and environmental factors on the expression of disease.

The life history of the Australian sea lion offers a unique comparative system to investigate the host–pathogen–environment relationship in the epidemiology of neonatal hookworm infection. Australian sea lions exhibit an extended breeding cycle of approximately 18 months, with 90 % of pups in each colony typically born over a 4–5-month period (Higgins 1993; Gales et al. 1994; McIntosh et al. 2012), enabling an investigation of the effects of alternate ‘summer’ and ‘winter’ breeding seasons. Additionally, females demonstrate a high degree of natal site fidelity (Campbell et al. 2008; Lowther et al. 2012), facilitating an examination of the effects of colony-specific factors such as substrate type and host density. Two of the largest breeding colonies in South Australia, Seal Bay on Kangaroo Island and Dangerous Reef in Spencer Gulf, demonstrate disparate biogeographical features. Seal Bay extends over approximately 3 km of sandy beaches, rocky coastal platforms, and sand dunes covered predominantly with coast saltbush (*Atriplex cinerea*) and tea tree (*Melaleuca lanceolata*) scrub. The approximate pup production is 250 pups per breeding season (McIntosh et al. 2012). In contrast, Dangerous Reef is a low-lying granite and limestone island approximately 250-m long and 100-m wide, with minimal vegetation and a substrate of rock and guano. Given its geographical size and pup production of approximately 500 pups each breeding season (Goldsworthy et al. 2012), Dangerous Reef has a higher population density than Seal Bay.

The Australian sea lion is classified as endangered in the IUCN Red List of Threatened Species (Goldsworthy and Gales 2008) and an understanding of the role of infectious disease in population health and demography is a key knowledge gap for the species (Goldsworthy et al. 2009). Whilst *U. sanguinis* has been identified from Australian sea lion pups at both Seal Bay and Dangerous Reef, the epidemiology of infection in this host has not been reported (Marcus et al.

2014). Both colonies demonstrate an oscillating pattern of high and low pup mortality associated with summer and winter breeding seasons, respectively, at Seal Bay (summer high ~35 %; winter low ~23 %), and the opposite seasonal association at Dangerous Reef (winter high ~39 %; summer low ~14 %) (Goldsworthy et al. 2012; Goldsworthy et al. 2013). Most Australian sea lion pup mortality occurs before 2 months of age prior to pup emigration between colonies and, based on gross necropsy findings, has been largely attributed to trauma and starvation, although up to 49 % of mortality is attributed to ‘unknown cause’ (Higgins and Tedman 1990; Gales et al. 1992; McIntosh and Kennedy 2013). As Australian sea lion females first give birth during the alternate season to which they were born (Gales et al. 1994), proportionally more primiparous females will give birth during high mortality breeding seasons due to the increased survival of low mortality breeding season pup cohorts. Having potentially accumulated tissue-stage hookworm larvae over an extended period of time, primiparous females may transmit higher numbers of hookworm larvae to their pups compared to multiparous females, potentially contributing towards higher pup mortality rates and the maintenance of the oscillating pattern of pup mortality. However, the role of disease and the factors contributing towards this pattern of mortality are unknown (Goldsworthy et al. 2013).

This study investigates the hypothesis of neonatal transmammary transmission of *U. sanguinis* in the Australian sea lion and determines the timing of key life cycle events. The prevalence and intensity of hookworm infection in *N. cinerea* pups are determined to test the hypothesis that hookworm infection is a significant agent of disease in Australian sea lion pups and that hookworm infection dynamics may contribute to the cyclical pup mortality at Seal Bay and Dangerous Reef. The interaction of host–pathogen–environment factors that may influence the epidemiology and impact of hookworm infection on pup morbidity and mortality are investigated. The findings of this study will contribute towards a greater understanding of the determinants of population health and demography and to informing conservation management of this endangered pinniped species.

Materials and methods

Study sites and sample collection

Field work was conducted during consecutive breeding seasons at Seal Bay (35.994° S, 137.317° E) in 2010 and 2012 and at Dangerous Reef (34.815° S, 136.212° E) in 2011 and 2013, facilitating data collection from one winter and one summer breeding season, respectively, at each colony. Pup mortality was high in 2011 (38.9 %) and 2012 (41.4 %) and low in 2010 (24.5 %) (Goldsworthy et al. 2012; Goldsworthy

et al. 2013). Pup mortality data are not available for the 2013 Dangerous Reef breeding season, but it was considered likely to be a low mortality season on the basis of historical trends (Goldsworthy et al. 2012).

For both live pups and pups found dead, standard length (straight line distance from nose to tail tip to the nearest 0.5 cm), body weight (measured to the nearest 0.1 kg; Salter hanging scale, Avery Weigh-Tronix, West Midlands, UK), and pup sex were recorded. Body condition was classified as poor, fair, good, or excellent, based upon the palpable prominence of the vertebral spinous processes, the pelvic bones, and skeletal muscle and adipose tissues. Moulting status was classified as non-moulting or moulting based on the presence of lighter-coloured pelage in moulting pups.

Live pups: Australian sea lion pups ($n=437$) were captured by hand or net during maternal absence and manually restrained within canvas bags for examination and sample collection. During 2010, pups ≥ 10 kg were sampled on one occasion only, whilst in other years, pups including those < 10 kg body weight were captured on up to three occasions at least 14 days apart. The standard length and body weight of pups across all capture events were 60.0–95.5 cm (median 72.5 cm; $n=537$) and 5.1–23.1 kg (median 10.7 kg; $n=537$), respectively. Faecal samples ($n=559$) were obtained per rectum using rayon-tipped dry swabs (Copan Diagnostics, Murrieta, USA) within a lubricated open-ended polyethylene sheath (modified 1–3-ml transfer pipette, Livingstone International, Sydney, Australia) and were also collected from the ground if known pups were observed to defecate at other times. Faecal samples were stored cooled at 4 °C or frozen at –20 °C prior to analysis. As part of ongoing population studies and to facilitate individual pup identification for recapture, sampled pups were uniquely identified by a bleach mark on their lumbosacral pelage (Schwarzkopf Nordic Blonde, Henkel Australia, Melbourne, Australia), a subcutaneous passive integrated transponder (23-mm microchip, Allflex Australia, Brisbane, Australia), and/or tags applied to the trailing edge of both fore-flippers (Supertag Size 1 Small, Dalton ID, Oxfordshire, UK). Bleach marks were no longer present after the first moult commencing at approximately 3–4 months of age (Gales et al. 1994).

Pups found dead: Australian sea lion pups found dead were collected for immediate necropsy where possible ($n=87$) or were frozen at –20 °C until necropsy was performed ($n=17$). The standard length and body weight of examined pups were 54.0–84.0 cm (median 70 cm; $n=101$) and 3.8–18.4 kg (median 6.3 kg; $n=99$), respectively. Necropsy data from an additional 27 pups were excluded from this study due to previous treatment with an anthelmintic or due to insufficient sample collection. Faeces were ‘milked’ from the transected descending colon and stored cooled at 4 °C or frozen at

–20 °C prior to analysis. The entire small intestine was transferred to a clean bucket, the mesentery and mesenteric lymph node were removed, and the intestine was straightened by hand. One litre of rainwater (Seal Bay) or seawater (Dangerous Reef) was added to the bucket, and the entire length of the small intestine was opened with blunt-tipped scissors and rinsed. The small intestine was then examined and run between the fore-finger and thumb so that all free and attached hookworms were retained. The entire intestinal contents ($n=90$) or representative 25-ml triplicate aliquots ($n=7$) were preserved with 10 % neutral buffered formalin (Fronine, Sydney, Australia).

Determination of pup age

The extended breeding season of the Australian sea lion precludes the estimation of pup age based on peak parturition dates, a method utilised in other otariid species (Lyons et al. 2005; Castinel et al. 2007; Ramos 2013). Standard length and moult status were instead used as proximate measures of age. In 2012, a cohort of known-age pups ($n=72$) was identified at Seal Bay by recording the geographic location and identity (microchip/tag number, distinctive scars) of female Australian sea lions with newborn pups during daily or twice-weekly observations. Parturition dates were thereby determined with an accuracy of 0–4 days. Pups were captured at approximately 14 days of age for marking and sampling. Misidentification prior to first capture was considered unlikely due to the low density of animals and the minimal movement of pups away from the site of parturition within the first few weeks of life in this colony. Subsequent observations of maternal–pup pairs confirmed pup identity and provided birthdates for other marked pups. Faecal and intestinal samples ($n=145$; 1–4 time points per pup) were collected from pups aged 0–137 days.

Hookworm infection status

Hookworm eggs per gram of faeces (EPG) were estimated using a modified McMaster flotation with saturated NaCl solution. For small faecal samples, a direct smear was examined to determine the presence/absence of hookworm eggs. Hookworm infection intensity in dead pups was estimated from total or aliquot counts of the posterior ends of hookworm specimens examined at $\times 8$ –50 magnification using a Nikon SMZ–2B stereomicroscope (Nikon, Tokyo, Japan) and the sex of worms was recorded. Pup hookworm infection status was classified as patent (faecal samples containing eggs), negative (live pups with no eggs in faeces; dead pups with no eggs in faeces and no intestinal hookworm specimens observed at necropsy), or prepatent (dead pups without eggs in faeces but with intestinal hookworms observed at necropsy). Thus, the ‘negative’

group may have included prepatent infections in live pups.

Statistical analysis

Hookworm prevalence: Crude prevalence was calculated separately for live and dead pups as the number of hookworm-positive (patent or prepatent) samples divided by the total number of samples. The patency of hookworm infection in dead pups was calculated as the number of dead pups with patent infection divided by the total number of hookworm-positive dead pups, and associations with colony (Seal Bay/Dangerous Reef), season (winter/summer), mortality level (high/low), and year of sampling (representing the interaction between colony and season) were analysed with maximum likelihood chi-square tests. The crude period prevalence was calculated for each breeding season as the number of pups with at least one hookworm-positive sample divided by the total number of live and dead pups sampled. Stillborn pups ($n=4$) were excluded from statistical analysis.

To assess the association of hookworm infection prevalence in live pups with potential risk factors (standard length, body weight, body condition, moult status, pup sex, and year of sampling), generalised linear mixed models (GLMM) with a binomial distribution and logit link function were fitted to the data. The factors colony, season, and mortality level were excluded due to aliasing with year of sampling, providing greater resolution to investigate factor effects. Pup identity was specified as the random factor to account for the repeated-measures design. Models were constructed by the backwards stepwise removal of parameters with low explanatory power (Wald F -test $P>0.05$). The results of the fitted model are presented graphically and reported as odds ratios with 95 % confidence intervals (CI). The association of hookworm infection prevalence in dead pups with potential risk factors was assessed as for live pups, excluding the random factor. Due to small sample sizes for pups found dead, the categorical levels of body condition ‘good’ ($n=8$) and ‘excellent’ ($n=2$) were combined and moulting pups ($n=4$) were excluded from model construction. Prevalence data from pups of known age were categorised according to hookworm infection status, and descriptive statistics are presented. The results of the GLMM and known-age pup analysis were used to determine selection criteria to calculate the proximate-age-specific period prevalence as an estimate of the true occurrence of hookworm infection.

Hookworm infection intensity: The association between hookworm infection intensity in dead pups and potential risk factors was assessed using general linear models (GLM) fitted using REML. Models were constructed as for hookworm prevalence, with infection patency and age included as additional potential risk factors in the models. Results are reported

as predicted back-transformed means with 95 % CI and were compared using Fisher's protected LSD. Descriptive statistics of hookworm infection intensity of pups born at Seal Bay in 2012 to females of known birth cohort are also presented. To investigate the utility of hookworm egg counts to predict infection intensity, differences in EPG between live and dead pups was assessed using linear mixed models fitted using REML with a normal distribution and identity link function. Pup identity was specified as the random factor and an appropriate correlation structure was chosen using the change in deviance. The number of hookworms of each sex in dead pups was tested for equality using a two-sample paired T-test. The relationship between EPG and hookworm infection intensity in dead pups was modelled using GLM, constructed as detailed earlier. For each model, where appropriate, the assumptions of homogeneity of residual variance and normality were checked by visually assessing the fitted value plots and histograms of residuals, and linearity of continuous predictors was accepted in binomial models for correlation coefficients ≥ 0.7 of the log odds of categorised variates against their midpoint; where necessary, the data were power or log-transformed. The amount of variance explained by the models was estimated using the marginal coefficient of determination (R^2_m ; fixed factors only) and the conditional coefficient of determination (R^2_c ; fixed and random factors) following the method of Nakagawa and Schielzeth (2013). Negative R^2_c values resulting from negative variance components of the random model were adjusted to zero. All statistical analyses were performed using GenStat 16.1 (VSN International, Hemel Hempstead, UK) and statistical significance was considered at $P < 0.05$.

Results

Hookworm prevalence

Crude measures of hookworm prevalence for Australian sea lion pups at Seal Bay and Dangerous Reef are shown in Table 1. The age structure of pups found dead, as indicated

by the level of patency, did not significantly differ with colony ($\chi^2 = 0.21$, $df = 1$, $P = 0.649$), season ($\chi^2 = 0.02$, $df = 1$, $P = 0.893$), or year of sampling ($\chi^2 = 5.75$, $df = 3$, $P = 0.125$); however, the association between patency and mortality level approached significance ($\chi^2 = 3.52$, $df = 1$, $P = 0.061$), with a greater proportion of dead pups having prepatent infections during high mortality seasons (34.4 %; $n = 64$) compared to low mortality seasons (15.4 %; $n = 26$).

The GLMM demonstrated that the probability of detecting hookworm infection in live pups was significantly associated with standard length ($F_{1, 451} = 11.83$, $P < 0.001$), moult status ($F_{1, 451} = 21.10$, $P < 0.001$), and year of sampling ($F_{3, 451} = 6.51$, $P < 0.001$). Individual variability did not contribute to model variance ($R^2_m = R^2_c = 52$ %). Body weight, body condition, and pup sex did not contribute significantly to the model fit. The likelihood of hookworm infection decreased by 37.0 % (CI 18.0–51.7 %) for each 5-cm increase in standard length, and non-moulting pups were 5.0 (CI 2.5–10.0) times more likely to be infected than moulting pups. Pups sampled during the summer breeding season at Dangerous Reef were 14.7–30.7 times more likely to be infected compared to pups sampled during the other three breeding seasons (Table 1 of the “Electronic supplementary material”). There were no significant differences in the likelihood of hookworm infection between pups sampled during these other breeding seasons (Table 1 of the “Electronic supplementary material”). Figure 1 demonstrates the effects of standard length, moult status, and the interaction between colony and season (year of sampling) on the probability of detecting hookworm infection in live pups.

For pups found dead, no significant association ($P > 0.05$) was identified between the prevalence of hookworm infection and potential risk factors; however, the number of hookworm-negative dead pups was low (Table 1). *Uncinaria sanguinis* was the only macroscopic parasite identified in the gastrointestinal tract of pups.

Hookworm prevalence in known-age pups: The hookworm infection status of known-age Australian sea lion pups is shown in Fig. 2. The prevalence of hookworm infection was 100 % for all pups aged 12–57 days ($n = 58$; 94 time points).

Table 1 Crude prevalence of hookworm (*U. sanguinis*) infection in Australian sea lion (*N. cinerea*) pups at Seal Bay and Dangerous Reef during consecutive breeding seasons

	Live pups		Pups found dead				Live and dead pups		
	Crude prevalence %	<i>n</i> (samples)	Crude prevalence %	<i>n</i> (pups)	Patency %	<i>n</i> (pups)	Crude period prevalence %	<i>n</i> (samples)	<i>n</i> (pups)
Seal Bay—winter (2010)	40.0	100	91.7	24	81.0	21	50.0	124	122
Seal Bay—summer (2012)	68.3	183	93.5	46	68.3	41	84.3	229	134
Dangerous Reef—winter (2011)	72.6	186	95.8	24	60.9	23	83.0	210	182
Dangerous Reef—summer (2013)	96.7	90	83.3	6	100	5	96.5	96	85

Fig. 1 Predicted probability of hookworm (*U. sanguinis*) infection by standard length and moult status in Australian sea lion (*N. cinerea*) pups at Seal Bay and Dangerous Reef during consecutive winter and summer breeding seasons

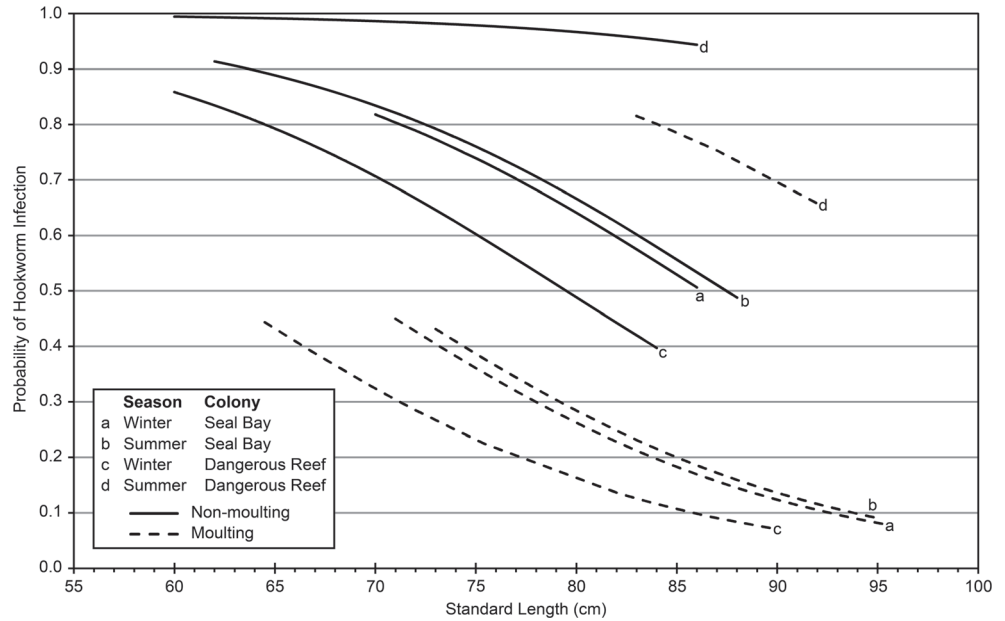

Four stillborn pups and one pup that died shortly after parturition and prior to suckling were negative for hookworm infection. Prepatent infection was identified in dead pups aged 6–14 days ($n=10$), whilst patent infection was identified in pups aged 11–101 days ($n=54$; 98 time points). No eggs were present in the faeces of live pups aged 6–11 days ($n=5$); however, patent infection was subsequently identified in four

of these pups that were re-sampled at 20, 23–26, 27, and 53–55 days at capture ($n=2$) or necropsy ($n=2$). Apparent recovery from hookworm infection, as evidenced by the cessation of faecal egg shedding, occurred from 59 days of age in pups with a minimum standard length of 70.5 cm ($n=22$; 27 time points). Re-infection was not observed. Evidence of moulting was observed from 67–69 days of age ($n=11$ pups; Fig. 2).

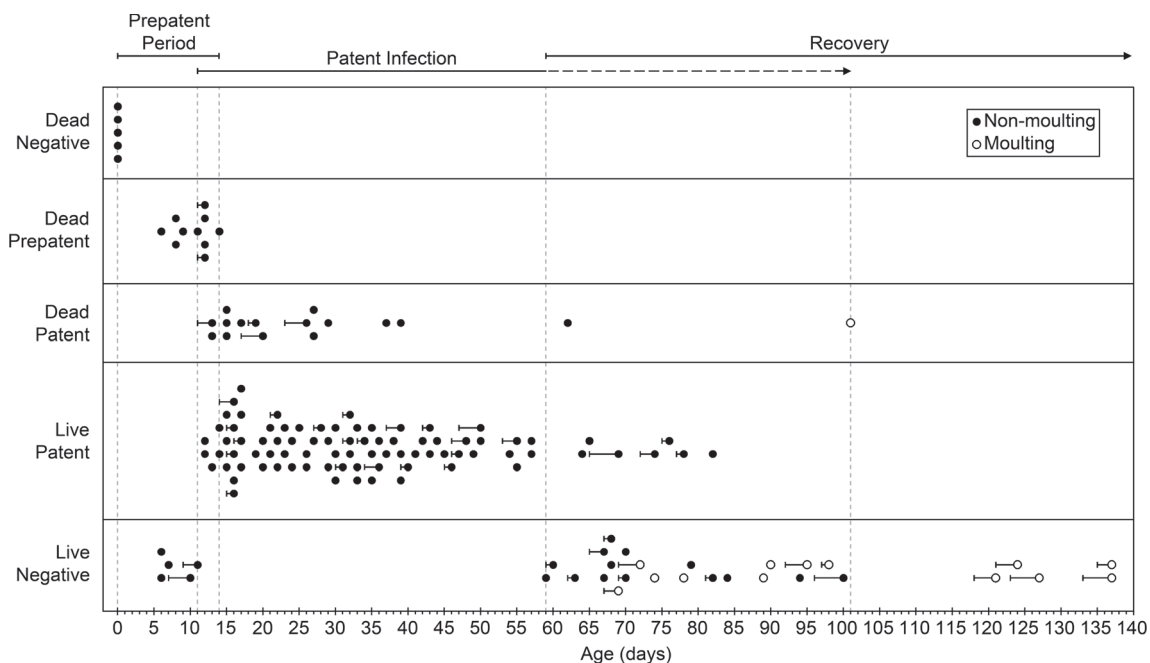

Fig. 2 Hookworm (*U. sanguinis*) infection status of known-age Australian sea lion (*N. cinerea*) pups at Seal Bay in 2012. Circles represent the maximum age and hookworm infection status of individual pups at each sampling event ($n=145$); error bars indicate the range of absolute uncertainty for pup age (0–

4 days). Non-moulting pups are indicated by *filled circles* and moulting pups by *open circles*. Hookworm infection status was categorised as patent, negative, or prepatent for live and dead pups. The timing of the prepatent period, patent infection, and recovery from infection are indicated

Estimated occurrence of hookworm infection: The GLMM risk analysis and known-age pup analysis were used to determine selection criteria to estimate the true occurrence of hookworm infection; the proximate age-specific period prevalence was calculated for pups with (1) more than one sampling event, (2) non-moulting at first sample collection, and (3) standard length ≤ 70.0 cm at first sample collection. Using these criteria, the estimated occurrence of hookworm infection in Australian sea lion pups is 100 % (CI 86.8–100 %; $n=26$) at Seal Bay and 96.7 % (CI 82.8–99.9 %; $n=30$) at Dangerous Reef.

Hookworm infection intensity

The intensity of hookworm infection in dead pups ranged from 1 to 8880 worms (mean 2138 ± 552 , CI 1698–2629; $n=86$). The GLM ($R^2_m=28$ %) demonstrated that hookworm infection intensity in dead pups was significantly associated with body condition ($F_{2, 79}=4.25$, $P=0.018$) and year of sampling ($F_{3, 79}=6.74$, $P<0.001$). Standard length, body weight, pup sex, pup age, and hookworm patency did not contribute significantly to the model fit. Significantly higher ($P<0.05$) infection intensity was seen in pups in poor (mean 1594, CI 1053–2247) and fair body condition (mean 1515, CI 879–2322) when compared to pups in good-to-excellent condition (mean 243, CI 0–1017); there was no significant difference ($P>0.05$) in infection intensity in pups in poor and fair body condition. At Seal Bay, infection intensity was significantly higher ($P<0.05$) during the summer breeding season (mean 2165, CI 1493–2962) compared to the winter breeding season (mean 745, CI 276–1444). Conversely, pups at Dangerous Reef had significantly lower ($P<0.05$) infection intensity during the summer breeding season (mean 67, CI 0–861) compared to the winter breeding season (mean 1927, CI 1142–2916). Overall, the intensity of hookworm infection was significantly higher ($P<0.05$) during high mortality seasons compared to low mortality seasons; hookworm infection intensity was not significantly different ($P>0.05$) between Seal Bay and Dangerous Reef or between summer and winter breeding seasons.

No apparent difference was observed in hookworm infection intensity in dead pups less than 1 month of age born to females from different birth cohorts at Seal Bay: median hookworm infection intensities were 3960 ($n=1$, maternal-cohort: 2001, winter); 2380 (range 1380–5820; $n=3$, cohort: 2004, winter); 2280 (680–7160; $n=5$, cohort: 2006, summer); and 3097 (2693–3500; $n=2$, cohort: 2007, winter).

The number of hookworm eggs in pup faeces (live and dead) ranged from 4–142500 EPG (mean 4427 ± 97 , CI 3532–5482; $n=191$). No significant difference in EPG was identified when live and dead pups were compared ($F_{1, 189}=0.37$, $P=0.542$, $R^2_m=0$ %, $R^2_c=0$ %). In pups found dead, significantly higher ($t=3.84$, $df=85$, $P<0.001$) numbers of

female hookworms were present in the intestines (mean 1122, CI 893–1376) compared to the number of male hookworms present (mean 1000, CI 783–1243). However, the mean difference of 3.5 worms (CI 0.8–8.0) was not considered biologically important and no significant difference was identified when assuming random independent sampling of female and male hookworms (two-sample T-test: $t=0.73$, $df=170$, $P=0.469$), representing a population level sample. No significant relationship was identified for EPG and total hookworm infection intensity ($F_{1, 32}=0.04$, $P=0.839$, $R^2_m=0$ %) or for EPG and female hookworm infection intensity ($F_{1, 31}=0.43$, $P=0.518$, $R^2_m=1$ %).

Discussion

Life cycle of *U. sanguinis* in *N. cinerea*

The life cycle of *U. sanguinis* in the Australian sea lion appears to follow the typical pattern for *Uncinaria* spp. in otariids (Olsen and Lyons 1965; Sepúlveda and Alcaíno 1993; Lyons et al. 2003; Castinel et al. 2007). *Uncinaria sanguinis* infects Australian sea lion pups shortly after birth, demonstrating a prepatent period of 11–14 days and an approximate duration of infection of 2–3 months. Evidence implicating transmammary transmission as the predominant route of hookworm infection for Australian sea lion neonatal pups is provided by the findings of the present study: the absence of hookworm infection in stillborn pups or pups that have not suckled, suggesting that patent infections are not acquired in utero; the identification of hookworm infection in pups from 6 days of age across a range of substrate types, indicating that colony substrate is unlikely to be the primary source of infective larvae for pups; and the short duration of overlap between the prepatent period and patent infection, indicating that the timing of infection is similar for all pups. These findings are consistent with those of Marcus et al. (2014) who observed little intra-host variation in the size of *U. sanguinis* specimens, indicating that Australian sea lion pups are infected with *U. sanguinis* over a relatively short period of time. Transplacental transmission has been identified for several parasitic species, including the hookworms *Ancylostoma caninum* and *Necator americanus* (Shoop 1991; Lyons 1994); however, similar to the present study, there was no evidence of prenatal infection with *Uncinaria* spp. in studies of the northern fur seal, New Zealand sea lion, and dogs (Walker and Jacobs 1982; Lyons 1994; Castinel et al. 2007). Orally or percutaneously acquired free-living larvae cannot be excluded as possible routes of patent infection in this host, although given the range of substrate types and the need for large numbers of larvae to be acquired acutely to fit with the observed data, it appears unlikely that free-living larvae contribute significantly to

infection intensity and mortality in neonatal pups. Investigation of the occurrence of tissue-stage larvae and patent infection in older cohorts, as well as the role of host physiological states as drivers of larval hypobiosis, reactivation, and migration (Shoop 1991), is required to further elucidate details of the *U. sanguinis* life cycle.

Occurrence and significance of hookworm infection

The crude prevalence of hookworm infection in otariid pups, typically considered to represent age-specific prevalence with reference to population peak parturition dates, has been used to estimate the true occurrence and dynamics of hookworm infection in other otariid species (Sepúlveda and Alcaíno 1993; Lyons et al. 2005; Castinel et al. 2007; Ramos 2013) but is not an appropriate measure in Australian sea lion pups. As the extended breeding season of this species results in substantial cohort age heterogeneity, the crude prevalence of hookworm infection likely underestimates the true occurrence due to the failure to detect prepatent infections in live pups and the inclusion of negative samples from older pups that have recovered from infection. For example, the crude prevalence of hookworm infection was 68 % for live pups at Seal Bay in 2012, whereas the age-specific prevalence (12–57 days) was 100 %. For this reason, the true occurrence of hookworm infection in pups of unknown age was estimated using (1) repeated temporal sampling to address prepatency and (2) age proxies (standard length and moult status) to restrict sampling to pups likely to be less than 2 months of age, demonstrating that the endemic occurrence of *U. sanguinis* is effectively 100 % at both colonies. Whilst cohort age heterogeneity in other otariid species is not as extreme as in the Australian sea lion, failure to detect hookworm infection due to methodological limitations or recovery from infection have been noted to underestimate prevalence (DeLong et al. 2009) and is recognised as a limitation in studies of other parasites in free-ranging hosts (Huffman et al. 1997; Hamer et al. 2013; Spada et al. 2013). The reported crude prevalence of hookworm infection in other otariid species is highly variable, likely due to differences in both sampling methodology and the true occurrence of hookworm infection. Hence, comparisons between studies must be undertaken cautiously. The implementation of repeated sampling and age (or age proxy) restriction may improve the accuracy of estimates of pathogen occurrence.

The in situ infection intensity of some nematode species, for example, *Haemonchus contortus* in sheep and *T. tenuis* in red grouse, may be estimated from faecal egg counts (Shaw and Moss 1989; Coyne and Smith 1992); however, no significant relationship was identified between EPG and hookworm infection intensity in Australian sea lion pups found dead. For this reason, the in situ infection intensity in individual live pups remains unknown. Factors noted to confound the

estimation of hookworm infection intensity from EPG in human and canine hosts include density-dependent fecundity, host immune responses, and random daily variation in egg production (Krupp 1961; Anderson and Schad 1985; Pritchard et al. 1995). Additionally, the finding in this study of slightly higher numbers of female compared to male hookworms in individual pups suggests that differential survival or longevity of hookworm sexes may occur (Poulin 1997), further confounding estimation of total infection intensity. The sensitivity of hookworm infection diagnosis in live pups may be influenced by EPG fluctuating below the threshold of detection, providing further support for repeated temporal sampling to accurately determine the infection status of individual pups. Considering these limitations, EPG is not a reliable measure of the intensity of hookworm infection in Australian sea lion pups and therefore cannot be correlated with clinical parameters to determine the impact on individual pup health. However, given no significant differences in EPG between live and dead Australian sea lion pups were identified, the intensity of hookworm infection in these two groups may be cautiously considered similar; seasonal fluctuations in the intensity of infection in pups found dead are presumed to also occur in live pups.

The role of *U. sanguinis* as a significant agent of disease and mortality in Australian sea lion pups is supported by the relationship between hookworm infection intensity and body condition, pup mortality, and the age of dead pups. The association between high hookworm infection intensity and poor body condition in Australian sea lion pups found dead suggests that hookworm infection adversely impacts pup growth rates, presumably via nutrient and energy loss through gastrointestinal haemorrhage and the increased energy requirements associated with the inflammatory response to hookworm infection. Increased growth rates were observed in New Zealand sea lion and northern fur seal pups following anthelmintic administration to reduce hookworm infection intensity (Chilvers et al. 2009; DeLong et al. 2009). Similarly, during the summer breeding season at Dangerous Reef, the significantly increased probability of hookworm infection and the apparent delay in the onset of moulting in Australian sea lion pups, compared to all other seasons (Fig. 1), may be due to increased growth rates as a result of the presumed lower hookworm infection intensity during this season.

The association of higher hookworm infection intensity with higher colony pup mortality suggests that hookworm infection causes intensity-dependent pup mortality. The mean hookworm infection intensity of dead Australian sea lion pups (2138±552 worms) is greater than that implicated in pup mortality in the New Zealand sea lion (mean 824; Castinel et al. 2007), South American fur seal (range 120–200; Seguel et al. 2013), northern fur seal (means 643, 1200; Lyons et al. 1997; Mizuno 1997), and California sea lion (means 612,

1284; Lyons et al. 1997; Lyons et al. 2001). In contrast, comparatively low hookworm infection intensity was not associated with pup mortality in the Australian fur seal (*Arctocephalus pusillus doriferus*, range 2–18; Ramos 2013), Juan Fernandez fur seal (mean 17; Sepúlveda 1998), and South American sea lion (means 38, 135; Berón-Vera et al. 2004; Hernández-Orts et al. 2012). This causative link is supported further by the relative decrease in the age of dead Australian sea lion pups during high-infection-intensity seasons and substantiates the finding that juvenile (prepatent) *U. sanguinis* are functionally capable of causing disease (Marcus et al. 2014). In known-age Australian sea lion pups, the majority of mortality occurred prior to 1 month of age (Fig. 2), providing evidence for the acute impact of hookworm infection. Investigation on the clinical health status of live Australian sea lion pups is essential to further characterise the impact of this important pathogen.

Host–pathogen–environment drivers of hookworm infection

The role of maternal parity as a significant factor influencing the epidemiology of *U. sanguinis* in Australian sea lion pups remains uncertain. In dogs, a greater proportion of *A. caninum* larvae are transmitted via the transmammary route when tissue-stage larvae are acquired prior to pregnancy (Burke and Roberson 1985). Hence, primiparous Australian sea lion females, having potentially accumulated tissue-stage larvae over an extended period of time prior to pregnancy and parturition, were hypothesised to transmit higher numbers of hookworm larvae to their pups compared to multiparous females. In the present study, no apparent differences in the intensity of hookworm infection were observed between pups born to primiparous females (birth cohort 2007; approximately 4.5 years prior) and those born to older multiparous females (cohorts 2001, 2004, and 2006); however, only small numbers of pups from each cohort were available, precluding robust statistical analysis. Additional data examining the survival rates and hookworm infection intensities of pups born to known-age females across several seasons are required to further explore this hypothesis and determine its contribution towards pup morbidity and mortality.

In Australian sea lion pups, there is limited evidence to support the supposition that higher hookworm infection intensity and better body condition is related to greater milk intake, as reported for dead northern fur seal, California sea lion, and Juan Fernandez fur seal pups (Sepúlveda 1998; Lyons et al. 2001; Lyons et al. 2005). The significant association between high hookworm infection intensity and poor body condition suggests that, in this species, infection intensity is relatively independent of milk intake or that any benefit from additional milk intake is outweighed by the clinical impact of increased infection intensity. Additionally, there is significant intraspecific variation in the energy content of the

milk of lactating Australian sea lions, indicating that pup body condition is not directly dependent on the quantity of milk intake (Kretzmann et al. 1991; Baylis et al. 2009; Lowther and Goldsworthy 2011).

Long-term survival of free-living larvae appears unlikely to be an essential factor for the successful maintenance of *U. sanguinis* populations in the Australian sea lion. Although greater hookworm infection intensity and prevalence are typically associated with sandy substrates (Sepúlveda 1998; Lyons et al. 2000b; Lyons et al. 2005; Ramos 2013), no significant differences in the overall infection intensity and prevalence were identified between Seal Bay and Dangerous Reef, biogeographically disparate colonies representing the archetypal sandy and rocky substrate types, respectively. The environmental persistence of *U. sanguinis* larvae at these colonies is unknown but, given the extended duration of the Australian sea lion breeding season and the minimum duration of infection in pups, free-living larvae are expected to be present in the colony substrate for at least 6 months during each breeding cycle.

Fluctuations in the intensity of hookworm infection in Australian sea lion pups may be mediated by colony-specific seasonal differences in host behaviour (i.e. seasonal-dependent biogeography) influencing local host aggregation (fine-scale density) and subsequent exposure to free-living larvae. Local host aggregation is recognised as an important factor influencing the transmission and prevalence of *Elaphostrongylus cervi* in red deer (*Cervus elaphus*) (Vicente et al. 2006) and *Protostrongylus* spp. in bighorn sheep (*Ovis canadensis*) (Rogerson et al. 2008). As the number of larvae acquired between the preceding breeding season and parturition directly affects the number transmitted to canine pups (Stoye 1973; Burke and Roberson 1985), presumably large numbers of larvae must be acquired by Australian sea lion females during low mortality seasons to cause the higher infection intensities observed in pups in high mortality seasons and vice versa. At Seal Bay, during winter breeding seasons (when large numbers of larvae must be acquired), individuals may be more likely to be closely aggregated on land and seek shelter from inclement weather in caves and under vegetation (Stirling 1972; Higgins and Gass 1993; Marcus, pers. obs.), areas frequented by pups and likely contaminated with free-living hookworm larvae. In summer, fine-scale density may be relatively reduced as animals are less likely to aggregate closely; thereby, exposure to pup faecal-contaminated areas may be less frequent. In contrast, at Dangerous Reef, individuals during winter may be more likely to emigrate sooner due to a paucity of shelter, reducing mean colony density and temporal exposure to free-living larvae, whereas in summer (when large numbers of larvae must be acquired), the impetus to emigrate may be reduced, relatively increasing colony density and temporal exposure to hookworm larvae. Observations of reduced host aggregation

during high mortality seasons relative to low mortality seasons at Australian sea lion colonies in Western Australia (Gales et al. 1992) provide additional support for seasonally-dependent biogeography modulating pup mortality, although the occurrence of hookworm infection in these populations has not been reported. Additional behavioural observations and determination of fine-scale habitat usage over several seasons at Seal Bay and Dangerous Reef are required to further investigate this hypothesis. Unlike the seasonally-dependent positive and negative effects of cowpox virus infection in wood mice and bank voles (Telfer et al. 2002), the seasonally-dependent effects of hookworm infection in Australian sea lion pups, that is, increased infection intensity associated with decreased body condition and increased mortality, are principally negative. The beneficial effects, if any, of hookworm infection to surviving pups are unknown, although high infection intensities may stimulate the development of protective immunity (Davey et al. 2013) with potential implications for the immune response to, and susceptibility to, other parasites (Christensen et al. 1987) and for the subsequent transmammary transmission of hookworm larvae.

Conclusion

This study found that all Australian sea lion pups at Seal Bay and Dangerous Reef, two of the largest breeding colonies in South Australia, are endemically infected with *U. sanguinis*, most likely via the transmammary route in the immediate post-parturient period. In this species, the prepatent period is 11–14 days and the duration of hookworm infection is approximately 2–3 months. The dynamic interaction between colony, season, and host behaviour influenced the intensity of hookworm infection; higher hookworm infection intensity was significantly associated with higher colony pup mortality and reduced pup body condition. Although the findings of seasonal-dependent biogeography modulating the intensity of hookworm infection implicates *U. sanguinis* in cyclic pup mortality, the presence of endemic parasitic infection could play a secondary role amplifying fluctuations driven by other factors (Tompkins et al. 2011). Investigation over additional breeding seasons is paramount to determine whether the observed pattern is fixed for these colonies and to elucidate the contribution of other mechanisms such as long-term climatic systems (McIntosh et al. 2013). To establish causality and quantify the effects of hookworm infection on pup health and survival, it is essential to associate infection with changes in clinical parameters and verify these observations via experimental manipulation of the course of infection (Irvine 2006); the results of these concurrent empirical studies will be reported elsewhere.

The findings of this study support the hypothesis that *U. sanguinis* is a significant agent of disease in Australian sea lion pups and could play an important role in population regulation. This improved understanding of the epidemiology of hookworm infection in the Australian sea lion adds a new perspective to understanding the dynamics of otariid hookworm infection, has significant implications for investigations of developmental ontogeny and health, and provides critical baseline information on endemic disease for conservation management.

Acknowledgements We thank the staff at Seal Bay, Department of Environment, Water and Natural Resources (DEWNR), South Australia for logistical support, field assistance and the collection of deceased pups, in particular Clarence Kennedy and Janet Simpson. We thank Rebecca McIntosh of La Trobe University and Phillip Island Nature Parks for the implementation of the comprehensive microchipping program at Seal Bay and Clarence Kennedy of DEWNR and Simon Goldsworthy of the South Australian Research and Development Institute for the ongoing maintenance of this monitoring program. Thank you to Tony Jones and Adam Kemp of Protec Marine, Port Lincoln, South Australia, for providing transport and logistical support for field work at Dangerous Reef. We also thank Evelyn Hall of The University of Sydney and Michael Terkildsen for statistical advice; Denise McDonnell of The University of Sydney for laboratory assistance; and volunteers and colleagues for field assistance: Liisa Ahlstrom, Loreena Butcher, Michael Edwards, Simon Goldsworthy, Benjamin Haynes, Claire Higgins, Janet Lackey, Zoe Larum, Theresa Li, Andrew Lowther, Rebecca McIntosh, Paul Rogers, Laura Schmertmann, Adrian Simon, Ryan Tate, Michael Terkildsen, Mark Whelan, Peter White, Sy Woon and Mariko Yata. This work was supported by the Australian Marine Mammal Centre, Department of the Environment, Australian Government (grant number 09/17). All samples were collected under the Government of South Australia Department of Environment, Water and Natural Resources Wildlife Ethics Committee approvals (3–2008 and 3–2011) and Scientific Research Permits (A25008/4-8).

Conflict of interest The authors declare that they have no conflict of interest.

References

- Albon SD, Stien A, Irvine RJ, Langvatn R, Ropstad E, Halvorsen O (2002) The role of parasites in the dynamics of a reindeer population. *Proc R Soc Lond B* 269:1625–1632. doi:10.1098/rspb.2002.2064
- Anderson RM, Schad GA (1985) Hookworm burdens and faecal egg counts: an analysis of the biological basis of variation. *Trans R Soc Trop Med Hyg* 79:812–825. doi:10.1016/0035-9203(85)90128-2
- Baylis AMM, Hamer DJ, Nichols PD (2009) Assessing the use of milk fatty acids to infer the diet of the Australian sea lion (*Neophoca cinerea*). *Wildl Res* 36:169–176. doi:10.1071/WR08046
- Baylis HA (1933) A new species of the nematode genus *Uncinaria* from a sea-lion, with some observations on related species. *Parasitology* 25: 308–316. doi:10.1017/S0031182000019508
- Baylis HA (1947) A redescription of *Uncinaria lucasi* Stiles, a hookworm of seals. *Parasitology* 38:160–162. doi:10.1017/S0031182000023118
- Berón-Vera B, Crespo EA, Raga JA, Pedraza SN (2004) *Uncinaria hamiltoni* (Nematoda: Ancylostomatidae) in South American sea

- lions, *Otaria flavescens*, from Northern Patagonia, Argentina. J Parasitol 90:860–863. doi:10.1645/GE-182R
- Burke TM, Roberson EL (1985) Prenatal and lactational transmission of *Toxocara canis* and *Ancylostoma caninum*: experimental infection of the bitch at midpregnancy and at parturition. Int J Parasitol 15: 485–490. doi:10.1016/0020-7519(85)90041-4
- Campbell RA, Gales NJ, Lento GM, Baker CS (2008) Islands in the sea: extreme female natal site fidelity in the Australian sea lion, *Neophoca cinerea*. Biol Lett 4:139–142. doi:10.1098/rsbl.2007.0487
- Castinel A, Duignan PJ, Lyons ET, Pomroy WE, Gibbs NJ, Lopez-Villalobos N, Chilvers BL, Wilkinson IS (2007) Epidemiology of hookworm (*Uncinaria* spp.) infection in New Zealand (Hooker's) sea lion (*Phocarcetos hookeri*) pups on Enderby Island, Auckland Islands (New Zealand) during the breeding seasons from 1999/2000 to 2004/2005. Parasitol Res 101:53–62. doi:10.1007/s00436-006-0453-z
- Chilvers BL, Duignan PJ, Robertson BC, Castinel A, Wilkinson IS (2009) Effects of hookworms (*Uncinaria* sp.) on the early growth and survival of New Zealand sea lion (*Phocarcetos hookeri*) pups. Polar Biol 32:295–302. doi:10.1007/s00300-008-0559-0
- Christensen NØ, Nansen P, Fagbemi BO, Monrad J (1987) Heterologous antagonistic and synergistic interactions between helminths and between helminths and protozoans in concurrent experimental infection of mammalian hosts. Parasitol Res 73:387–410. doi:10.1007/BF00538196
- Coyne MJ, Smith G (1992) The mortality and fecundity of *Haemonchus contortus* in parasite-naïve and parasite-exposed sheep following single experimental infections. Int J Parasitol 22:315–325. doi:10.1016/S0020-7519(05)80009-8
- Davey D, Manickam N, Simms BT, Harrison LM, Vermeire JJ, Cappello M (2013) Frequency and intensity of exposure mediate resistance to experimental infection with the hookworm, *Ancylostoma ceylanicum*. Exp Parasitol 133:243–249. doi:10.1016/j.exppara.2012.11.010
- DeLong RL, Orr AJ, Jenkinson RS, Lyons ET (2009) Treatment of northern fur seal (*Callorhinus ursinus*) pups with ivermectin reduces hookworm-induced mortality. Mar Mamm Sci 25:944–948. doi:10.1111/j.1748-7692.2008.00274.x
- Gales NJ, Cheal AJ, Pobar GJ, Williamson P (1992) Breeding biology and movements of Australian sea-lions, *Neophoca cinerea*, off the west coast of Western Australia. Wildl Res 19:405–416. doi:10.1071/WR9920405
- Gales NJ, Shaughnessy PD, Dennis TE (1994) Distribution, abundance and breeding cycle of the Australian sea lion *Neophoca cinerea* (Mammalia: Pinnipedia). J Zool 234:353–370. doi:10.1111/j.1469-7998.1994.tb04853.x
- George-Nascimento M, Lima M, Ortiz E (1992) A case of parasite-mediated competition? Phenotypic differentiation among hookworms *Uncinaria* sp. (Nematoda: Ancylostomatidae) in sympatric and allopatric populations of South American sea lions *Otaria byronia*, and fur seals *Arctocephalus australis* (Carnivora: Otariidae). Mar Biol 112:527–533. doi:10.1007/BF00346169
- Goldsworthy SD, Gales NJ (2008) *Neophoca cinerea*. In: IUCN red list of threatened species. Version 2013.2. <http://www.iucnredlist.org/details/14549>. Accessed 1 May 2014
- Goldsworthy SD, McKenzie J, Shaughnessy PD, McIntosh RR, Page B, Campbell RA (2009) An update of the report: understanding the impediments to the growth of Australian sea lion populations. SARDI Publication Number F2008/00847-1. SARDI Research Report series No. 356, Adelaide, Australia
- Goldsworthy SD, Page B, Lowther AD, Shaughnessy PD (2012) Maintaining the monitoring of pup production at key Australian sea lion colonies in South Australia (2010/11). SARDI Publication Number F2010/000665-2. SARDI Research Report series no. 601, Adelaide, Australia
- Goldsworthy SD, Lowther AD, Shaughnessy PD (2013) Maintaining the monitoring of pup production at key Australian sea lion colonies in South Australia (2011/12). SARDI Publication Number F2010/000665-3. SARDI Research Report series no. 739, Adelaide, Australia
- Hamer GL, Anderson TK, Berry GE, Makohon-Moore AP, Crafton JC, Brawn JD, Dolinski AC, Krebs BL, Ruiz MO, Muzzall PM, Goldberg TL, Walker ED (2013) Prevalence of filarioid nematodes and trypanosomes in American robins and house sparrows, Chicago USA. Int J Parasitol Parasites Wildl 2:42–49. doi:10.1016/j.ijppaw.2012.11.005
- Haynes BT, Marcus AD, Šlapeta J, Gray R (2013) Hookworms (*Uncinaria* sp.) do not segregate according to the restriction of the host, the Australian sea lion (*Neophoca cinerea*). Honours Dissertation, The University of Sydney
- Hernández-Orts JS, Montero FE, Juan-García A, García NA, Crespo EA, Raga JA, Aznar FJ (2012) Intestinal helminth fauna of the South American sea lion *Otaria flavescens* and fur seal *Arctocephalus australis* from northern Patagonia, Argentina. J Helminthol 1:1–12. doi:10.1017/S0022149X12000454
- Higgins LV, Tedman RA (1990) Effect of attacks by male Australian sea lions, *Neophoca cinerea*, on mortality of pups. J Mammal 71:617–619. doi:10.2307/1381802
- Higgins LV (1993) The nonannual, nonseasonal breeding cycle of the Australian sea lion, *Neophoca cinerea*. J Mammal 74:270–274. doi:10.2307/1382381
- Higgins LV, Gass L (1993) Birth to weaning: parturition, duration of lactation, and attendance cycles of Australian sea lions (*Neophoca cinerea*). Can J Zool 71:2047–2055. doi:10.1139/z93-290
- Hudson PJ, Dobson AP, Newborn D (1998) Prevention of population cycles by parasite removal. Science 282:2256–2258. doi:10.1126/science.282.5397.2256
- Huffman MA, Gotoh S, Turner LA, Hamai M, Yoshida K (1997) Seasonal trends in intestinal nematode infection and medicinal plant use among chimpanzees in the Mahale Mountains, Tanzania. Primates 38:111–125. doi:10.1007/BF02382002
- Irvine RJ (2006) Parasites and the dynamics of wild mammal populations. Anim Sci 82:775–781. doi:10.1017/ASC2006106
- Katz H, Morgades D, Castro-Ramos M (2012) Pathological and parasitological findings in South American fur seal pups (*Arctocephalus australis*) in Uruguay. ISRN Zool. doi:10.5402/2012/586079
- Keyes MC (1965) Pathology of the northern fur seal. J Am Vet Med Assoc 147:1090–1095
- Kretzmann MB, Costa DP, Higgins LV, Needham DJ (1991) Milk composition of Australian sea lions, *Neophoca cinerea*: variability in lipid content. Can J Zool 69:2556–2561. doi:10.1139/z91-360
- Krupp IM (1961) Effects of crowding and of superinfection on habitat selection and egg production in *Ancylostoma caninum*. J Parasitol 47:957–961. doi:10.2307/3275030
- Lowther AD, Goldsworthy SD (2011) Maternal strategies of the Australian sea lion (*Neophoca cinerea*) at Dangerous Reef, South Australia. Aust J Zool 59:54–62. doi:10.1071/ZO11025
- Lowther AD, Harcourt RG, Goldsworthy SD, Stow A (2012) Population structure of adult female Australian sea lions is driven by fine-scale foraging site fidelity. Anim Behav 83:691–701. doi:10.1016/j.anbehav.2011.12.015
- Lyons ET, Keyes MC (1984) Further indication of viability of larvae of the hookworm (*Uncinaria lucasi*) for several years in tissues of northern fur seals (*Callorhinus ursinus*). J Parasitol 70:459–460. doi:10.2307/3281589
- Lyons ET (1994) Vertical transmission of nematodes: emphasis on *Uncinaria lucasi* in northern fur seals and *Strongyloides westeri* in equids. J Helminthol Soc Wash 61:169–178
- Lyons ET, DeLong RL, Melin SR, Tolliver SC (1997) Uncinariasis in northern fur seal and California sea lion pups from California. J Wildl Dis 33:848–852. doi:10.7589/0090-3558-33.4.848

- Lyons ET, DeLong RL, Gulland FMD, Melin SR, Tolliver SC, Spraker TR (2000a) Comparative biology of *Uncinaria* spp. in the California sea lion (*Zalophus californianus*) and the northern fur seal (*Callorhinus ursinus*) in California. *J Parasitol* 86:1348–1352. doi:10.2307/3285025
- Lyons ET, Spraker TR, Olson KD, Tolliver SC, Bair HD (2000b) Prevalence of hookworms (*Uncinaria lucasi* Stiles) in northern fur seal (*Callorhinus ursinus* Linnaeus) pups on St. Paul Island, Alaska, U.S.A.: 1986–1999. *Comp Parasitol* 67:218–223
- Lyons ET, Melin SR, DeLong RL, Orr AJ, Gulland FMD, Tolliver SC (2001) Current prevalence of adult *Uncinaria* spp. in northern fur seal (*Callorhinus ursinus*) and California sea lion (*Zalophus californianus*) pups on San Miguel Island, California, with notes on the biology of these hookworms. *Vet Parasitol* 97:309–318. doi:10.1016/S0304-4017(01)00418-6
- Lyons ET, DeLong RL, Spraker TR, Melin SR, Tolliver SC (2003) Observations in 2001 on hookworms (*Uncinaria* spp.) in otariid pinnipeds. *Parasitol Res* 89:503–505. doi:10.1007/s00436-002-0784-3
- Lyons ET, DeLong RL, Spraker TR, Melin SR, Laake JL, Tolliver SC (2005) Seasonal prevalence and intensity of hookworms (*Uncinaria* spp.) in California sea lion (*Zalophus californianus*) pups born in 2002 on San Miguel Island, California. *Parasitol Res* 96:127–132. doi:10.1007/s00436-005-1335-5
- Lyons ET, Spraker TR, DeLong RL, Ionita M, Melin SR, Nadler SA, Tolliver SC (2011) Review of research on hookworms (*Uncinaria lucasi* Stiles, 1901) in northern fur seals (*Callorhinus ursinus* Linnaeus, 1758). *Parasitol Res* 109:257–265. doi:10.1007/s00436-011-2420-6
- Lyons ET, Kuzmina TA, Tolliver SC, Spraker TR (2012) Update on the prevalence of the hookworm, *Uncinaria lucasi*, in northern fur seals (*Callorhinus ursinus*) on St. Paul Island, Alaska, 2011. *Parasitol Res* 111:1397–1400. doi:10.1007/s00436-012-2881-2
- Marcus AD, Higgins DP, Šlapeta J, Gray R (2014) *Uncinaria sanguinis* sp. n. (Nematoda: Ancylostomatidae) from the endangered Australian sea lion, *Neophoca cinerea* (Carnivora: Otariidae). *Folia Parasitol*. doi:10.14411/fp.2014.037
- McIntosh RR, Goldsworthy SD, Shaughnessy PD, Kennedy CW, Burch P (2012) Estimating pup production in a mammal with an extended and aseasonal breeding season, the Australian sea lion (*Neophoca cinerea*). *Wildl Res* 39:137–148. doi:10.1071/WR10222
- McIntosh RR, Arthur AD, Dennis TE, Berris M, Goldsworthy SD, Shaughnessy PD, Teixeira CEP (2013) Survival estimates for the Australian sea lion: Negative correlation of sea surface temperature with cohort survival to weaning. *Mar Mamm Sci* 29:84–108. doi:10.1111/j.1748-7692.2011.00558.x
- McIntosh RR, Kennedy CW (2013) Morphology, sex ratio and cause of death in Australian sea lion (*Neophoca cinerea*) pups. *Aust Mammal* 35:93–100. doi:10.1071/AM12037
- Mizuno A (1997) Ecological study on the hookworm, *Uncinaria lucasi*, of northern fur seal, *Callorhinus ursinus*, in Bering Island, Russia. *Jpn J Vet Res* 45:109–110
- Nadler SA, Lyons ET, Pagan C, Hyman D, Lewis EE, Beckmen K, Bell CM, Castinel A, DeLong RL, Duignan PJ, Farinpour C, Huntington KB, Kuiken T, Morgades D, Naem S, Norman R, Parker C, Ramos PW, Spraker TR, Berón-Vera B (2013) Molecular systematics of pinniped hookworms (Nematoda: *Uncinaria*): species delimitation, host associations and host-induced morphometric variation. *Int J Parasitol* 43:1119–1132. doi:10.1016/j.ijpara.2013.08.006
- Nakagawa S, Schielzeth H (2013) A general and simple method for obtaining R^2 from generalized linear mixed-effects models. *Methods Ecol Evol* 4:133–142. doi:10.1111/j.2041-210x.2012.00261.x
- Olsen OW (1958) Hookworms, *Uncinaria lucasi* Stiles, 1901, in fur seals, *Callorhinus ursinus* (Linn.), on the Pribilof Islands. In: Trefethen JB (ed) Transactions of the twenty-third North American wildlife conference. St. Louis, Missouri, 3–5 March 1958. pp 152–175
- Olsen OW, Lyons ET (1965) Life cycle of *Uncinaria lucasi* Stiles, 1901 (Nematoda: Ancylostomatidae) of fur seals, *Callorhinus ursinus* Linn., on the Pribilof Islands, Alaska. *J Parasitol* 51:689–700. doi:10.2307/3276141
- Poulin R (1997) Population abundance and sex ratio in dioecious helminth parasites. *Oecologia* 111:375–380. doi:10.1007/s004420050248
- Pritchard DI, Quinnell RJ, Walsh EA (1995) Immunity in humans to *Necator americanus*: IgE, parasite weight and fecundity. *Parasite Immunol* 17:71–75. doi:10.1111/j.1365-3024.1995.tb00968.x
- Ramos PW (2013) Investigation of hookworm (*Uncinaria* sp.) parasites in free-ranging Australian fur seals (*Arctocephalus pusillus doriferus*). Masters Dissertation, The University of Melbourne
- Rogerson JD, Fairbanks WS, Cornicelli L (2008) Ecology of gastropod and bighorn sheep hosts of lungworm on isolated, semiarid mountain ranges in Utah, USA. *J Wildl Dis* 44:28–44. doi:10.7589/0090-3558-44.1.28
- Seguel M, Paredes E, Pavés H, Molina R, Henríquez F, De Groote F, Schlatter R (2011) Pathological findings in South American fur seal pups (*Arctocephalus australis gracilis*) found dead at Guafu Island, Chile. *J Comp Pathol* 145:308–317. doi:10.1016/j.jcpa.2011.01.006
- Seguel M, Paredes E, Pavés H, Gottdenker NL (2013) Capture-induced stress cardiomyopathy in South American fur seal pups (*Arctophoca australis gracilis*). *Mar Mamm Sci*. doi:10.1111/mms.12079
- Sepúlveda MS, Alcaíno H (1993) Helminthological fauna of the Juan Fernandez fur seal, *Arctocephalus philippii* (Peters, 1866). *Parasitol Dia* 17:19–24
- Sepúlveda MS (1998) Hookworms (*Uncinaria* sp.) in Juan Fernandez fur seal pups (*Arctocephalus philippii*) from Alejandro Selkirk Island, Chile. *J Parasitol* 84:1305–1307. doi:10.2307/3284700
- Shaw JL, Moss R (1989) The role of parasite fecundity and longevity in the success of *Trichostrongylus tenuis* in low density red grouse populations. *Parasitology* 99:253–258. doi:10.1017/S0031182000058704
- Shoop WL (1991) Vertical transmission of helminths: hypobiosis and amphiparatensis. *Parasitol Today* 7:51–54. doi:10.1016/0169-4758(91)90189-U
- Smith K, Acevedo-Whitehouse K, Pedersen A (2009) The role of infectious diseases in biological conservation. *Anim Conserv* 12:1–12. doi:10.1111/j.1469-1795.2008.00228.x
- Spada E, Proverbio D, Della Pepa A, Domenichini G, Bagnagatti De Giorgi G, Traldi G, Ferro E (2013) Prevalence of faecal-borne parasites in colony stray cats in northern Italy. *J Feline Med Surg* 15:672–677. doi:10.1177/1098612x12473467
- Spraker TR, DeLong RL, Lyons ET, Melin SR (2007) Hookworm enteritis with bacteremia in California sea lion pups on San Miguel Island. *J Wildl Dis* 43:179. doi:10.7589/0090-3558-43.2.179
- Stirling I (1972) Observations on the Australian sea lion, *Neophoca cinerea* (Peron). *Aust J Zool* 20:271–279. doi:10.1071/ZO9720271
- Stoye M (1973) Untersuchungen über die möglichkeit pränataler und galaktogener infektionen mit *Ancylostoma caninum* Ercolani 1859 (Ancylostomidae) beim hund. *Zbl Vet Med B* 20:1–39. doi:10.1111/j.1439-0450.1973.tb01098.x
- Telfer S, Bennett M, Bown K, Cavanagh R, Crespin L, Hazel S, Jones T, Begon M (2002) The effects of cowpox virus on survival in natural rodent populations: increases and decreases. *J Anim Ecol* 71:558–568. doi:10.1046/j.1365-2656.2002.00623.x
- Telfer S, Bennett M, Bown K, Carslake D, Cavanagh R, Hazel S, Jones T, Begon M (2005) Infection with cowpox virus decreases female maturation rates in wild populations of woodland rodents. *Oikos* 109:317–322. doi:10.1111/j.0030-1299.2005.13734.x
- Thompson RCA, Lymbery AJ, Smith A (2010) Parasites, emerging disease and wildlife conservation. *Int J Parasitol* 40:1163–1170. doi:10.1016/j.ijpara.2010.04.009

- Tompkins DM, Dunn AM, Smith MJ, Telfer S (2011) Wildlife diseases: from individuals to ecosystems. *J Anim Ecol* 80:19–38. doi:10.1111/j.1365-2656.2010.01742.x
- Twisleton-Wykeham-Fiennes RN (1966) The Zoological Society of London Report of the Society's Pathologist for the year 1963. *J Zool* 148:341–362. doi:10.1111/j.1469-7998.1966.tb02955.x
- Vicente J, Fernández de Mera IG, Gortazar C (2006) Epidemiology and risk factors analysis of elaphostrongylosis in red deer (*Cervus elaphus*) from Spain. *Parasitol Res* 98:77–85. doi:10.1007/s00436-005-0001-2
- Walker MJ, Jacobs DE (1982) Epidemiology of *Uncinaria stenocephala* infections in greyhound breeding kennels. *Vet Parasitol* 10:317–321. doi:10.1016/0304-4017(82)90083-8

Supplementary Table 1

The relative likelihood of detecting hookworm (*Uncinaria sanguinis*) infection in live Australian sea lion (*Neophoca cinerea*) pups at Seal Bay and Dangerous Reef during consecutive breeding seasons. Odds ratios with 95% confidence intervals are presented as the column breeding season relative to the row breeding season.

	Seal Bay – summer (2012)	Dangerous Reef – winter (2011)	Dangerous Reef – summer (2013)
Seal Bay – winter (2010)	1.1 (0.6–2.3)	0.5 (0.2–1.3)	16.4 (3.8–71.0)
Seal Bay – summer (2012)		0.5 (0.2–4.7)	14.7 (3.4–62.7)
Dangerous Reef – winter (2011)			30.7 (6.6–143.8)

Chapter 4



Health assessment of free-ranging endangered
Australian sea lion (*Neophoca cinerea*) pups: effect of
haematophagous parasites on haematological
parameters

Author contribution statement

This chapter was published by Elsevier Inc. as:

Marcus AD, Higgins DP, Gray R (2015) Health assessment of free-ranging endangered Australian sea lion (*Neophoca cinerea*) pups: effect of haematophagous parasites on haematological parameters. *Comp Biochem Physiol A Mol Integr Physiol* 184:132–143. doi:10.1016/j.cbpa.2015.02.017

Alan Marcus was the primary author of this publication and contributed towards all aspects including the study design, sample collection and analysis, and writing of the manuscript. Rachael Gray and Damien Higgins contributed towards the study design, sample collection, interpretation of findings, and critical revision of the manuscript.

Alan D. Marcus		Date	<u>2/6/2015</u>
Damien P. Higgins		Date	<u>4/6/2015</u>
Rachael Gray		Date	<u>2/6/2015</u>



Contents lists available at ScienceDirect

Comparative Biochemistry and Physiology, Part A

journal homepage: www.elsevier.com/locate/cbpa

Health assessment of free-ranging endangered Australian sea lion (*Neophoca cinerea*) pups: Effect of haematophagous parasites on haematological parameters



Alan D. Marcus, Damien P. Higgins, Rachael Gray*

Faculty of Veterinary Science, The University of Sydney, McMaster Building B14, Camperdown, New South Wales 2006, Australia

ARTICLE INFO

Article history:

Received 17 December 2014

Received in revised form 19 February 2015

Accepted 19 February 2015

Available online 25 February 2015

Keywords:

Antarctophthirus microchir

Australian sea lion

Bootstrap estimation

Haematology

Hookworm

Lice

Neophoca cinerea

Reference intervals

Uncinaria sanguinis

Wildlife disease

ABSTRACT

Evaluation of the health status of free-ranging populations is important for understanding the impact of disease on individuals and on population demography and viability. In this study, haematological reference intervals were developed for free-ranging endangered Australian sea lion (*Neophoca cinerea*) pups within the context of endemic hookworm (*Uncinaria sanguinis*) infection and the effects of pathogen, host, and environment factors on the variability of haematological parameters were investigated. *Uncinaria sanguinis* was identified as an important agent of disease, with infection causing regenerative anaemia, hypoproteinaemia, and a predominantly lymphocytic–eosinophilic systemic inflammatory response. Conversely, the effects of sucking lice (*Antarctophthirus microchir*) were less apparent and infestation in pups appears unlikely to cause clinical impact. Overall, the effects of *U. sanguinis*, *A. microchir*, host factors (standard length, body condition, pup sex, moult status, and presence of lesions), and environment factors (capture-type and year of sampling) accounted for 26–65% of the total variance observed in haematological parameters. Importantly, this study demonstrated that anaemia in neonatal Australian sea lion pups is not solely a benign physiological response to host–environment changes, but largely reflects a significant pathological process. This impact of hookworm infection on pup health has potential implications for the development of foraging and diving behaviour, which would subsequently influence the independent survival of juveniles following weaning. The haematological reference intervals developed in this study can facilitate long-term health surveillance, which is critical for the early recognition of changes in disease impact and to inform conservation management.

© 2015 Elsevier Inc. All rights reserved.

1. Introduction

Evaluation of the health status of free-ranging populations is important for understanding the impact of disease on individuals and on population demography and viability (Deem et al., 2001; Smith et al., 2009; Thompson et al., 2010). Haematological analysis is a reasonably non-invasive and efficient tool used as part of routine health assessment, permitting repeated *in situ* sampling of live individuals with minimal impact on animal welfare and survival (Clark, 2004; Wimsatt et al., 2005). Changes in haematological values provide quantifiable measures of the impact of, and host-response to, disease. However, inherent host-specific differences and dynamic temporospatial adaptations to physiological stressors also influence haematological characteristics (Gray et al., 2005; Beldomenico et al., 2008; Hufschmid et al., 2014). For this reason, the establishment of species- and context-specific reference intervals is necessary to define and assess deviations from baseline health

status (Sergent et al., 2004; Ceriotti et al., 2009). This would facilitate the implementation of long-term health surveillance, essential for both the early recognition of emerging disease and to inform species conservation management (Hall et al., 2007; Thompson et al., 2010).

As high trophic-level predators exploiting a variety of ecological niches, pinnipeds act as sentinels for marine ecosystem health (Bossart, 2011). In particular, the health status of maternally-dependent pinniped pups is sensitive to changes to pathogen–host–environment relationships such as shifts in prey abundance, major climatic events, the presence of environmental toxins and contaminants, the occurrence of infectious diseases, and increasing human-impacts (Beckmen et al., 2003; Soto et al., 2004; Greig et al., 2005; Castinel et al., 2007; Melin et al., 2010; Brock et al., 2013). Haematological reference intervals have been developed for pups of several pinniped species to facilitate health assessment and several studies have investigated haematological responses to physiological changes, identifying the influential role of host factors (for example age, body condition, and sex) and environment factors (including geographic location and capture-associated stress) (Bryden and Lim, 1969; Geraci, 1971; Lane et al., 1972; Banish and Gilmartin, 1988; Castellini et al., 1993, 1996; Horning and Trillmich, 1997; Hall, 1998; Rea et al., 1998; Sepúlveda

* Corresponding author at: McMaster Building B14, Faculty of Veterinary Science, The University of Sydney, Camperdown, New South Wales 2006, Australia. Tel.: +61 2 9351 2643; fax: +61 2 9351 7421.

E-mail address: rachael.gray@sydney.edu.au (R. Gray).

et al., 1999; Trumble and Castellini, 2002; Lander et al., 2003, 2014; Richmond et al., 2005; Boily et al., 2006; Clark et al., 2007; Trillmich et al., 2008; Greig et al., 2010; Brock et al., 2013). Yet, despite the widespread host distribution of haematophagous hookworm and lice species (Leonardi and Palma, 2013; Nadler et al., 2013), the effects of these parasites on the haematological values of pups and their implications for the assessment of health status remain unresolved. For example, although hookworm and lice can cause anaemia (Olsen, 1958; Dailey, 2001; Lyons et al., 2001), the population-wide occurrence of anaemia in neonates of many pinniped species has generally been attributed to a physiological host-response to the increased oxygen availability compared to the environment *in utero* and the expansion of plasma volume with growth (Richmond et al., 2005; Clark et al., 2007; Trillmich et al., 2008). A notable exception to the occurrence of neonatal anaemia is observed in land-bound northern elephant seal (*Mirounga angustirostris*) pups at Año Nuevo State Reserve (Castellini et al., 1990; Thorson and Le Boeuf, 1994) in which hookworm infection has not been detected (Lyons et al., 2012). Critically, few studies have considered parasitosis as a cause of anaemia in pinniped pups and there are no reports that characterise this anaemia by the presence or absence of reticulocytosis; classifying the erythroid response to anaemia as regenerative or non-regenerative in this way is fundamental to differentiating between pathological and physiological mechanisms (Stockham and Scott, 2008).

The impact of disease on the health status and population demography of the endangered Australian sea lion (*Neophoca cinerea*) is considered a key knowledge gap for understanding the impediments to population recovery in this species and for informing conservation management to mitigate the risks of population extinction (Goldsworthy et al., 2009). Whilst haematological reference intervals for free-ranging Australian sea lions older than six months of age have been reported (Needham et al., 1980; Fowler et al., 2007), data from neonatal pups is lacking. Additionally, the effects of disease on haematological values in this species have not been reported. Hookworm (*Uncinaria sanguinis*) endemically infects 100% of neonatal Australian sea lion pups at Seal Bay and Dangerous Reef in South Australia, two of the largest breeding colonies of this species, and is hypothesised to be an important agent of disease and cause of pup mortality across the species' range (Marcus et al., 2014a,b). Pups are infected *via* the transmammary route shortly after birth and demonstrate patent

infection from 11–14 days of age for approximately 2–3 months (Marcus et al., 2014a; see Fig. 1). The extended breeding season of the Australian sea lion (approximately 7–9 month duration; Goldsworthy et al., 2012; McIntosh et al., 2012) facilitates the high prevalence of hookworm infection in pups by increasing the period of time in which breeding females can acquire infective free-living hookworm larvae (Marcus et al., 2014a). Additionally, the extended breeding cycle of approximately 18 months results in alternate 'summer' and 'winter' breeding seasons, occurring asynchronously between colonies (Higgins, 1993; McIntosh et al., 2012). The magnitude of colony pup mortality is associated with fluctuations in the intensity of hookworm infection, mediated by seasonal and colony-specific factors; an oscillating pattern of high-pup-mortality-with-high-infection-intensity and low-pup-mortality-with-low-infection-intensity has been observed at Seal Bay for summer and winter breeding seasons, respectively, and the opposite seasonal association has been described for Dangerous Reef, reflecting the different environmental attributes of the two colonies (Goldsworthy et al., 2012, 2013; Marcus et al., 2014a). Infestation with sucking lice (*Antarctophthirus microchir*) is also reported in Australian sea lion pups (McIntosh and Murray, 2007), although the epidemiology and clinical impact of this parasite have not been investigated in this host.

The aim of this study is to develop haematological reference intervals for free-ranging neonatal Australian sea lion pups within the context of endemic hookworm infection. In addition, this study will investigate the impact of *U. sanguinis* and *A. microchir* on pup health by estimating their effects on the variability of haematological parameters whilst considering the concurrent influence of host and environment factors. In particular, by characterising the erythroid changes in anaemia, this study will assess the hypothesis that neonatal anaemia is non-pathological, caused predominantly by physiological responses to host–environment changes.

2. Materials and methods

2.1. Sample collection

Samples were collected from Australian sea lion pups ($n = 295$) during consecutive winter and summer breeding seasons at two South Australian colonies, Seal Bay, Kangaroo Island (35.994°S, 137.317°E) in

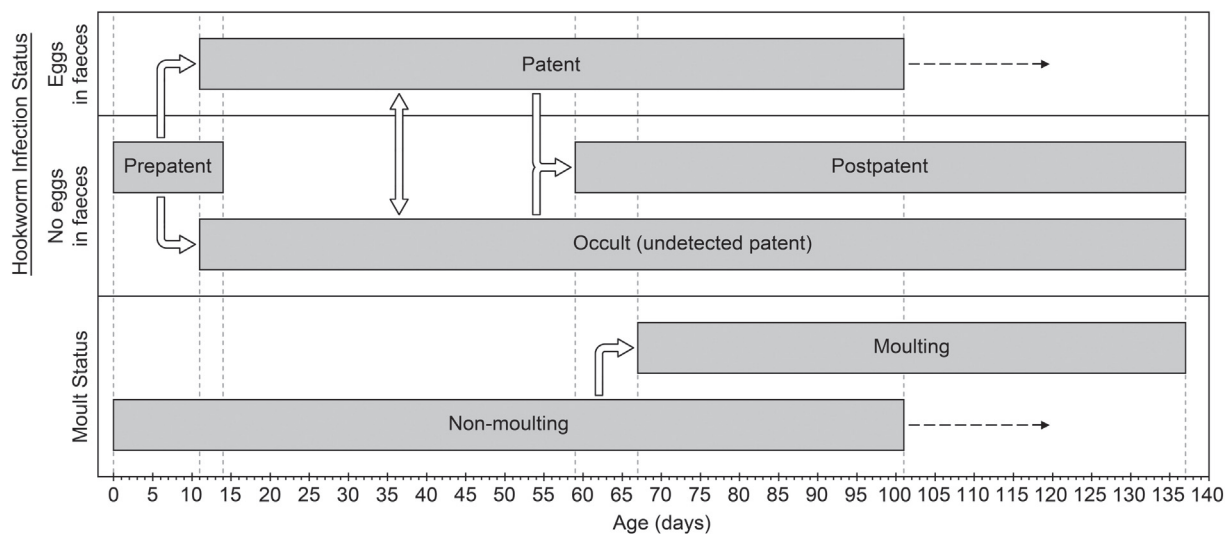

Fig. 1. Flowchart displaying the timing of hookworm (*Uncinaria sanguinis*) infection and moult status in neonatal Australian sea lion pups (*Neophoca cinerea*) from birth to 137 days of age. Grey boxes indicate the occurrence of each category with respect to pup age. White arrows indicate possible directions of change between categories. Dashed black arrows demonstrate the uncertainty in the upper limit for the occurrence of patent hookworm infection and non-moulting pups. Adapted from Marcus et al. (2014a).

2010 and 2012, and Dangerous Reef, Spencer Gulf (34.815°S, 136.212°E) in 2011 and 2013. During 2010, pups ≥ 10 kg were sampled on one occasion only, whilst in other years, pups including those < 10 kg body weight were captured for sample collection on up to three occasions at least 14 days apart. Based on the estimated or observed starting dates for pupping during each breeding season (Goldsworthy et al., 2012, 2013), the maximum possible age of sampled pups was approximately seven months. During the 2012 breeding season at Seal Bay, samples were also collected from a cohort of known-age pups ($n = 41$; aged 10–137 days).

Pups were captured by hand or net during maternal absence and restrained manually within canvas bags. Capture-type was categorised as sleeping, awake (pup alert, minimal pup exertion), or mobile (pup alert, captured after a short period of pup exertion). Standard length (measured to the nearest 0.5 cm), body weight (measured to the nearest 0.1 kg; Salter hanging scale, Avery Weigh-Tronix, West Midlands, UK), body condition (subjectively scored poor/fair/good/excellent based on the palpable prominence of the vertebral spinous processes, pelvic bones, and skeletal muscle and adipose tissues), pup sex, and moult status (non-moulting/moulting) were recorded. Pups were examined for the presence of clinically significant lesions (including dermatitis, cutaneous ulceration, and subcutaneous abscesses; absent/present) and the dorsal and ventral pelage of the thorax and abdomen was examined for the presence of ectoparasites (lice; categorised as negative/positive). Faecal samples were collected per rectum using rayon-tipped dry swabs (Copan Diagnostics, Murrieta, USA) within a lubricated open-ended polyethylene sheath (modified 1–3 mL transfer pipette, Livingstone International, Sydney, Australia) or from the ground if pups were observed to defecate.

Blood samples ($n = 387$) were collected from the brachial vein (Barnes et al., 2008) using 21-gauge \times 1-inch needles attached to 5 or 10 mL plastic syringes, transferred to 1.3 mL EDTA, lithium heparin, and plain serum tubes (Sarstedt, Nümbrecht, Germany), and stored at approximately 4 °C prior to processing. To facilitate individual pup identification for recapture, pups were uniquely identified by one or more of the following methods: a temporary bleach mark on their lumbosacral pelage (Schwarzkopf Nordic Blonde, Henkel Australia, Melbourne, Australia), a subcutaneous passive integrated transponder (23 mm microchip, Allflex Australia, Brisbane, Australia), and/or tags applied to the trailing edge of both fore-flippers (Supertag Size 1 Small, Dalton ID, Oxfordshire, UK).

2.2. Haematological analysis

EDTA anti-coagulated whole blood samples were processed for haematological analysis within 10 h of collection. Packed cell volume (PCV; L/L) was measured in duplicate in microhaematocrit tubes (IRIS Sample Processing, Westwood, USA) following centrifugation at 15,800 rpm for 120 s (StatSpin MP, StatSpin Technologies, Norwood, USA); mean values were utilised for statistical analysis. Total plasma protein (TPP; g/L) was measured using a hand-held refractometer (Reichert TS Meter, Cambridge Instruments, Buffalo, USA). Air-dried blood smears were fixed with 100% methanol and treated with a Romanowsky-type rapid stain (Diff Quik, Lab Aids, Sydney, Australia; or Rapid Diff, Australian Biostain, Traralgon, Australia) for examination using an Olympus BH-2 microscope (Olympus, Australia). Absolute reticulocyte counts (RET; $\times 10^9/L$) were performed by estimating the number of reticulocytes per 1000 erythrocytes on air-dried smears prepared by incubation of 50 μ L blood 1:1 with citrated 1% brilliant cresyl blue (Sigma Chemical, St. Louis, USA) for 20 min. Smears from samples collected at Seal Bay were examined immediately whilst those collected from Dangerous Reef were fixed with methanol for 20 s and examined at a later time. For blood samples collected from Seal Bay, total erythrocyte and leucocyte counts were performed using Ery-TIC and Leuko-TIC kits (Bioanalytic, Freiburg, Germany), respectively, using a Neubauer improved haemocytometer (Glaswarenfabrik Karl

Hecht, Sondheim, Germany). Erythrocytes in the five diagonal central group squares and leucocytes in all nine large squares of the haemocytometer were enumerated in duplicate at 400 \times magnification; mean values were utilised for statistical analysis. As field conditions at Dangerous Reef precluded use of the haemocytometer method for erythrocyte and leucocyte estimations, 100–200 μ L aliquots of EDTA anti-coagulated whole blood samples collected at Dangerous Reef were mixed 1:1 with Streck Cell Preservative (Streck, Omaha, USA) and stored at approximately 4 °C. Preserved samples were analysed using a Sysmex XT-2000iV automated haematology analyser (Sysmex, Kobe, Japan) at the Veterinary Pathology Diagnostic Service, Faculty of Veterinary Science, The University of Sydney within nine days of blood collection. Leucocyte counts (WBC; $\times 10^9/L$) were calculated by manually gating the WBC/BASO scattergram using the manufacturer's software (version 00-10; Sysmex) and one profile was applied to all analysed samples. Automated erythrocyte counts (RBC; $\times 10^{12}/L$) were calculated by the impedance method using default parameters. Values obtained were doubled to correct for dilution with cell preservative. To facilitate comparison of haematological parameters between Seal Bay and Dangerous Reef, manual haemocytometer counts were converted to Sysmex-equivalent values (Supplementary Material Appendix S1). Finally, differential leucocyte counts were performed on Romanowsky-type stained blood smears to determine the proportion of neutrophils, lymphocytes, monocytes, eosinophils, and basophils; one hundred leucocytes were identified for every $10 \times 10^9/L$ WBC. The proportion of nucleated erythrocytes (mainly late normoblasts) to leucocytes was also recorded to estimate absolute nucleated erythrocyte counts (nRBC; $\times 10^6/L$), corrected leucocyte counts (cWBC; $\times 10^9/L$), and absolute neutrophil, lymphocyte, monocyte, eosinophil, and basophil counts ($\times 10^9/L$). The equations used to calculate haematological values are presented in Supplementary Material Appendix S1. Due to the availability of test kits and occasional samples where an insufficient volume of blood was collected to permit complete haematological analysis, values for all haematological parameters could not be determined for every individual.

2.3. Hookworm infection status

Hookworm eggs were detected using a modified McMaster flotation with saturated NaCl solution or, for small faecal samples, a direct smear. Where eggs were evident in faecal samples, pups were classified as 'patent' ($n = 213$ pups; $n = 256$ time points). Where eggs were not evident, hookworm infection status was inferred based on pup age, moult status, and the timing of infection, or using repeated faecal samples (Marcus et al., 2014a; see Fig. 1): pups ≤ 14 days of age or with subsequent patent faecal samples were classified as 'prepatent' ($n = 6$ pups; $n = 7$ time points) and pups ≥ 59 days of age, showing signs of moult, or with previous patent faecal samples were classified as 'postpatent' ($n = 83$ pups; $n = 91$ time points). As such, the prepatent and postpatent groups could have included pups with occult (undetected patent) hookworm infection (Fig. 1). Hookworm infection status was considered to be unknown ($n = 33$) for non-moulting pups (or pups with no recorded moult status) of undetermined age with negative repeat faecal samples (or no repeat sample) and for those pups sampled for blood collection but with no faecal sample.

2.4. Statistical analysis

2.4.1. Haematological reference intervals

Nonparametric 95% reference intervals were calculated for haematological parameters (PCV, RBC, mean corpuscular volume, RET, nRBC, TPP, cWBC, and differential leucocyte counts), partitioned by hookworm infection status as a proxy for age and because haematological values were expected to significantly differ between groups. Outliers, values more than 1.5 times the interquartile range above or below the interquartile range (Tukey, 1977), were excluded from each group

prior to the development of reference intervals to improve the accuracy of the reference interval limits (Horn et al., 2001). To adjust for repeated measures from pups sampled on more than one occasion, reference intervals were developed for each parameter using bootstrap estimation (1000 replicates) with observations drawn randomly from the dataset with replacement and weighting to ensure equal probability of selection from individual pups, based on methodology described by Taylor et al. (1996) and Alatzas et al. (2014). For each bootstrap replicate, the reference interval (2.5th and 97.5th percentiles) and median value (50th percentile) were determined. Final estimates of the reference interval and median value for each parameter were calculated as the median of the replicated bootstrap percentile values. Approximate 95% confidence intervals (CI) were calculated around each estimate as the 2.5th and 97.5th percentiles of the replicated bootstrap percentile values (Efron, 1982). For pups with prepatent hookworm infection, minimum and maximum values are reported due to insufficient sample size for the calculation of nonparametric 95% reference intervals (Ceriotti et al., 2009) and median values were calculated as non-bootstrapped weighted values as bootstrapping may under-represent the true biological variability with small sample sizes (Chernick, 2011). Haematological data from pups with unknown hookworm infection status were excluded from reference interval development.

The validity of partitioning reference intervals based on hookworm infection status for pups with patent and postpatent hookworm infection was determined by observing the proportion of values in each group that fell outside of common reference limits (Lahti et al., 2004). The combined reference interval was developed by combining the outlier-removed datasets for these two groups and using bootstrap estimation, with observations weighted to adjust for both repeated measures and unequal numbers of reference values between the groups. Following the recommendations of Lahti et al. (2004), the combined reference interval for each parameter was considered invalid if $\geq 4.1\%$ or $\leq 0.9\%$ of reference values from either group, adjusted for repeated measures, were outside either the upper or the lower combined reference limits. Additionally, the underlying distributions of reference values for each parameter for these two groups were considered significantly different ($P < 0.01$) if their median CI did not overlap (Cumming, 2009).

The erythroid response to anaemia was classified as regenerative or non-regenerative based on the absolute reticulocyte count; a reticulocytosis greater than $65.0 \times 10^9/L$ was considered evidence of a regenerative erythroid response (Hodges and Christopher, 2011).

2.4.2. Factors explaining haematological parameter variability

Correlational analysis was performed to characterise the pattern of haematological changes associated with hookworm infection. Pairwise Spearman's rank correlations (ρ), partitioned by hookworm infection status, were calculated for all haematological parameters reported except for mean corpuscular volume (MCV) and cWBC as variability in these parameters is explained by the variability in PCV and RBC, and the differential leucocyte counts, respectively. To adjust for repeated measures from pups sampled on more than one occasion, median estimates of ρ with 95% CI were calculated using bootstrap replication as previously described. Correlations were categorised as 'weak' for $\rho < 0.35$, 'moderate' for $0.35 \leq \rho < 0.75$, and 'strong' for $\rho \geq 0.75$ (Shi and Conrad, 2009), and were considered statistically significant ($P < 0.05$) if their CI excluded zero. Haematological data from pups with prepatent hookworm infection were excluded from correlational analysis due to small sample size.

The effects of *U. sanguinis* and *A. microchir* on haematological parameters were investigated using linear mixed modelling with REML estimation. Terms prospectively included in the models as fixed factors were pathogen factors (hookworm infection status and presence of lice), host factors (standard length, body weight, body condition, pup sex, moult status, and presence of lesions), and environment factors (capture-type and year of sampling). Standard length, body weight,

and moult status were included as proxies for growth and pup age (Marcus et al., 2014a) as known-age pup data was only available for one breeding season. Presence of lesions was included as a factor to account for the variance related to the occurrence of other disease processes whilst the physiological effects of capture-associated stress were investigated by including capture-type as a factor. Year of sampling was included as a factor to represent the interaction between colony (Seal Bay/Dangerous Reef) and season (summer/winter). Pup-identity was specified as the random factor to account for repeated measures and an appropriate correlation structure was chosen using the change in model deviance. The assumptions of homogeneity of residual variance and normality were checked by visually assessing the fitted-value plots and histograms of residuals and, where necessary, the response variate was power or log-transformed. Models were constructed by the backwards stepwise removal of factors with the lowest explanatory power (highest Wald F-test P-value) to arrive at the final models that included only significant predictors ($P < 0.05$). The amount of variance explained by the final models was estimated using the marginal coefficient of determination (R^2_m ; fixed factors only) and the conditional coefficient of determination (R^2_c ; fixed and random factors) (Nakagawa and Schielzeth, 2013). The predicted effects of factors included in the final models are reported as the regression coefficient \pm standard error. For factors with more than two levels (body condition, capture-type, hookworm infection status, and year of sampling), the predicted level effects were considered significantly different ($P < 0.05$) if the 95% CI for their difference excluded zero. Model construction was undertaken for all haematological parameters except for MCV and cWBC as previously outlined. Haematological data from all sampled pups were prospectively included in model construction with listwise deletion employed to exclude cases with missing factor data for each model. All statistical analyses were performed using GenStat 16.1 (VSN International, Hemel Hempstead, UK) and statistical significance was considered at $P < 0.05$.

3. Results

3.1. Haematological reference intervals

Haematological reference intervals for Australian sea lion pups, partitioned by hookworm infection status, are presented in Table 1. The proportion of values identified as outliers for each hookworm infection status group are presented in Supplementary Table S1. Combined reference intervals for pups with patent and postpatent hookworm infection did not adequately represent the true distributions of reference values for any of the measured haematological parameters (Supplementary Table S2). When compared to pups with patent hookworm infection, postpatent pups had significantly higher median values ($P < 0.01$) and reference interval limits for PCV, RBC, and TPP; and significantly lower median values ($P < 0.01$) and reference interval limits for MCV, RET, nRBC, and all leucocyte parameters. Pups with prepatent hookworm infection had the highest median values for PCV, RBC, neutrophil, and monocyte counts; median values intermediate to the other hookworm infection status groups for RET, nRBC, TPP, cWBC, and lymphocyte counts; and the lowest median value for MCV. Median eosinophil counts were invariant between pups with prepatent and patent hookworm infection. Basophils were not identified in any of the blood smears examined.

The proportions of samples from pups with prepatent, patent, and postpatent hookworm infection that demonstrated a regenerative erythroid response were 66.7% (CI 22.3–95.7%), 65.0% (CI 58.7–71.0%), and 29.1% (CI 19.8–39.9%), respectively.

3.2. Factors explaining haematological parameter variability

For pups with patent hookworm infection, significant correlations were identified between most haematological parameters examined

Table 1
Nonparametric 95% haematological reference intervals and median values (with 95% confidence intervals) for neonatal Australian sea lion pups (*Neophoca cinerea*), partitioned by hookworm infection status. Values were calculated by bootstrap estimation which adjusted for repeated measures. Due to the small sample size for pups with prepatent hookworm infection, reference intervals for this group are presented as minimum–maximum with non-bootstrapped weighted median values.

Hookworm infection status	Prepatent			Patent			Postpatent		
	Min–max	Median	n ^a	95% RI	Median	n ^a	95% RI	Median	n ^a
Number of pups sampled	6			213			83		
PCV (L/L)	0.355–0.520	0.390	7	0.261–0.410 (0.245–0.278; 0.397–0.429)	0.340 (0.335–0.350)	244	0.284–0.440 (0.280–0.306; 0.430–0.455)	0.380 (0.370–0.389)	88
RBC ($\times 10^{12}/L$)	4.34–5.19	4.51	6	2.85–4.88 (2.54–3.03; 4.62–4.93)	3.75 (3.69–3.80)	236	3.43–5.34 (3.36–3.87; 5.13–5.46)	4.44 (4.35–4.53)	88
MCV (fL)	78.5–100.3	82.0	6	76.1–103.6 (74.5–77.2; 101.3–107.7)	90.1 (88.9–91.3)	233	65.1–96.2 (61.2–71.4; 94.7–100.5)	84.3 (82.5–86.3)	88
RET ($\times 10^9/L$)	0.0–117.2	78.5	6	13.0–203.8 (6.3–19.2; 180.1–209.1)	83.2 (75.1–87.2)	236	5.1–106.4 (4.0–10.0; 96.1–117.0)	45.1 (39.6–53.6)	85
nRBC ($\times 10^6/L$)	0.0–130.7	27.2	7	0.0–550.1 (0.0–0.0; 466.2–597.1)	92.6 (78.1–122.3)	224	0.0–127.1 (0.0–0.0; 97.7–135.1)	0.0 (0.0–0.0)	78
TPP (g/L)	58.0–75.0	70.5	7	51.8–86.2 (48.0–53.0; 81.3–87.7)	69.0 (66.0–70.0)	251	63.7–87.0 (62.0–66.1; 83.3–88.0)	72.0 (71.0–73.0)	89
cWBC ($\times 10^9/L$)	6.03–15.02	11.29	7	6.48–25.02 (5.40–6.88; 23.65–26.58)	12.12 (11.50–13.00)	237	3.74–15.18 (3.58–4.65; 13.57–18.53)	8.73 (7.92–9.25)	82
Neutrophils ($\times 10^9/L$)	3.26–9.54	7.91	7	2.47–20.13 (1.93–2.86; 17.30–21.01)	6.83 (6.37–7.49)	237	1.42–11.71 (1.08–2.14; 9.24–13.78)	4.91 (4.34–5.49)	82
Lymphocytes ($\times 10^9/L$)	1.30–3.57	2.85	7	1.44–5.99 (1.19–1.60; 5.65–6.27)	3.18 (2.99–3.40)	241	0.94–5.01 (0.67–1.19; 4.55–5.08)	2.55 (2.34–2.85)	85
Monocytes ($\times 10^9/L$)	0.11–0.47	0.45	6	0.00–1.07 (0.00–0.00; 0.90–1.18)	0.31 (0.28–0.34)	240	0.00–0.70 (0.00–0.00; 0.54–0.73)	0.17 (0.12–0.23)	83
Eosinophils ($\times 10^9/L$)	0.24–2.18	1.13	7	0.05–3.54 (0.00–0.08; 3.22–3.80)	1.13 (0.95–1.41)	246	0.06–1.24 (0.03–0.11; 1.00–1.28)	0.42 (0.34–0.50)	82

^a Sample size after outlier removal. Abbreviations: cWBC – corrected leucocyte count; MCV – mean cell volume; nRBC – absolute nucleated erythrocyte count; PCV – packed cell volume; RBC – erythrocyte count; RET – absolute reticulocyte count; RI – reference interval; TPP – total plasma protein.

(26 of 36 pairs; Table 2), whereas for postpatent pups, fewer significant correlations were observed (15 of 36 pairs; Table 3). Strong correlations ($\rho \geq 0.75$) were not identified in either dataset. The moderate correlations ($0.35 \leq \rho < 0.75$) between haematological parameters are summarised below; all pairwise correlation coefficients (with 95% CI) are presented in Tables 2 and 3.

For both groups of pups there was significant moderate positive correlation between PCV/RBC and RET/nRBC; however, only pups with patent hookworm infection demonstrated evidence for regenerative responses with significant moderate negative correlation of PCV/nRBC and RBC/nRBC and significant weak negative correlation of PCV/RET and RBC/RET. Postpatent pups had non-significant correlations between PCV/nRBC, RBC/nRBC, PCV/RET, and RBC/RET. For pups with patent hookworm infection, there was significant moderate positive

correlation between RBC/TPP, significant moderate negative correlation between RBC/neutrophil-count and TPP/eosinophil-count, and significant weak negative correlation between RBC/eosinophil-count. In contrast, postpatent pups had significant weak negative correlation between RBC/TPP and RBC/neutrophil-count, non-significant correlation between TPP/eosinophil-count, and significant moderate negative correlation between RBC/eosinophil-count. Postpatent pups also had significant moderate positive correlation between TPP/lymphocyte-count and nRBC/monocyte-count, whilst pups with patent hookworm infection had significant weak negative correlation and non-significant correlation for these pairs, respectively.

The final linear mixed models assessing the effects of pathogen, host, and environment factors on the variability of pup haematological parameters are presented in Table 4 (effects; erythrocytes and TPP),

Table 2
Spearman's rank correlation of haematological parameters in neonatal Australian sea lion pups (*Neophoca cinerea*) with patent hookworm (*Uncinaria stenocephala*) infection, calculated by bootstrap estimation to adjust for repeated measures. Median bootstrap replicate values (with 95% confidence intervals) of the correlation coefficient (top right triangle) and sample sizes (bottom left triangle) are presented. Values indicated in **bold** were statistically significant ($P < 0.05$).

	PCV	RBC	RET	nRBC	TPP	Neutrophils	Lymphocytes	Monocytes	Eosinophils
PCV		0.71 (0.62, 0.78)	–0.26 (–0.38, –0.14)	–0.41 (–0.51, –0.30)	0.20 (0.07, 0.32)	–0.30 (–0.41, –0.17)	–0.24 (–0.36, –0.11)	0.17 (0.06, 0.30)	–0.06 (–0.18, 0.07)
RBC	242		–0.21 (–0.32, –0.07)	–0.37 (–0.48, –0.26)	0.37 (0.24, 0.49)	–0.37 (–0.49, –0.25)	–0.26 (–0.38, –0.13)	0.04 (–0.10, 0.18)	–0.13 (–0.25, –0.005)
RET	240	243		0.43 (0.32, 0.53)	–0.07 (–0.20, 0.06)	0.08 (–0.07, 0.20)	0.10 (–0.02, 0.23)	–0.03 (–0.16, 0.10)	0.19 (0.06, 0.31)
nRBC	247	242	242		–0.19 (–0.32, –0.07)	0.04 (–0.08, 0.16)	0.22 (0.09, 0.34)	–0.04 (–0.16, 0.09)	0.25 (0.13, 0.37)
TPP	251	241	239	246		0.09 (–0.04, 0.20)	–0.17 (–0.29, –0.04)	0.17 (0.05, 0.30)	–0.35 (–0.46, –0.23)
Neutrophils	247	242	242	250	246		0.18 (0.06, 0.30)	0.16 (0.03, 0.29)	–0.22 (–0.34, –0.10)
Lymphocytes	247	242	242	250	246	250		–0.05 (–0.17, 0.07)	0.29 (0.17, 0.40)
Monocytes	247	242	242	250	246	250	250		–0.17 (–0.29, –0.04)
Eosinophils	247	242	242	250	246	250	250	250	

Table 3

Spearman's rank correlation of haematological parameters in neonatal Australian sea lion pups (*Neophoca cinerea*) with postpatent hookworm (*Uncinaria stenocephala*) infection, calculated by bootstrap estimation to adjust for repeated measures. Median bootstrap replicate values (with 95% confidence intervals) of the correlation coefficient (top right triangle) and sample sizes (bottom left triangle) are presented. Values indicated in **bold** were statistically significant ($P < 0.05$).

	PCV	RBC	RET	nRBC	TPP	Neutrophils	Lymphocytes	Monocytes	Eosinophils
PCV		0.57 (0.39, 0.70)	−0.13 (−0.36, 0.09)	−0.15 (−0.36, 0.05)	−0.08 (−0.29, 0.14)	− 0.28 (− 0.49, −0.06)	0.02 (−0.18, 0.23)	0.21 (−0.01, 0.43)	− 0.31 (− 0.50, −0.10)
RBC	90		−0.17 (−0.36, 0.05)	−0.21 (−0.40, 0.001)	− 0.33 (− 0.53, −0.13)	− 0.34 (− 0.55, −0.14)	−0.05 (−0.26, 0.15)	−0.03 (−0.25, 0.19)	− 0.39 (− 0.55, −0.20)
RET	85	86		0.39 (0.20, 0.57)	0.12 (−0.10, 0.34)	0.27 (0.06, 0.48)	0.06 (−0.17, 0.28)	0.06 (−0.14, 0.27)	0.28 (0.07, 0.48)
nRBC	85	86	85		0.06 (−0.15, 0.28)	0.25 (0.07, 0.44)	−0.09 (−0.29, 0.13)	0.37 (0.17, 0.53)	0.25 (0.03, 0.43)
TPP	90	91	86	86		0.30 (0.08, 0.49)	0.36 (0.16, 0.55)	−0.13 (−0.33, 0.08)	0.05 (−0.15, 0.27)
Neutrophils	85	86	85	86	86		0.12 (−0.10, 0.33)	0.06 (−0.14, 0.29)	0.15 (−0.07, 0.36)
Lymphocytes	85	86	85	86	86	86		−0.17 (−0.35, 0.04)	−0.01 (−0.21, 0.22)
Monocytes	85	86	85	86	86	86	86		0.23 (0.002, 0.43)
Eosinophils	85	86	85	86	86	86	86	86	

Table 5 (effects; leucocytes), and Supplementary Table S3 (P-values), and are summarised below. The final models accounted for 26–65% of the total variance observed in haematological parameters with differences between individual pups explaining up to 28% of the variability.

3.2.1. Effects of pathogen factors

Patent hookworm infection was associated with significantly lower PCV, RBC, and TPP values and significantly higher nRBC and eosinophil counts, relative to pups with prepatent infection. Postpatent hookworm infection status was associated with significantly higher RBC and TPP values and significantly lower nRBC, lymphocyte, and eosinophil counts, relative to pups with patent hookworm infection. However, PCV and RBC values remained significantly lower compared to those pups with prepatent hookworm infection. Hookworm infection status was not significantly associated with RET, neutrophil, or monocyte counts.

The presence of lice (identified in 73.3% of sampling events; see Supplementary Table S4) was also associated with a significant decrease in PCV, although the magnitude of effect was markedly less than that for patent hookworm infection (Table 4). In contrast to patent hookworm infection, lice infestation was associated with significantly increased TPP concentrations. No other significant effects were identified for lice infestation for the remainder of the haematological parameters.

3.2.2. Effects of host factors

Increases in standard length were associated with significant increases in PCV, RBC, and TPP values and significant decreases in RET, nRBC, and all leucocyte parameters. The presence of moult was also associated with significant decreases in RET, but did not have significant effects on any of the other haematological parameters.

Body condition was a significant host factor in the final models. Pups in excellent body condition had significantly higher nRBC compared to all other pups. Similarly, TPP values significantly increased with improving body condition although the effect of poor body condition was not significantly different from the other categorical levels. Pups in fair body condition had significantly lower eosinophil counts compared to pups in good or excellent body condition; however, as for TPP, the effect of poor body condition on eosinophil counts was not significantly different from the other categorical levels. Compared to female pups, male pups had significantly lower PCV and RBC values. The presence of lesions was associated with significantly higher neutrophil counts. No other significant effects were identified for body condition, pup sex, or the presence of lesions for the remainder of the haematological parameters. Body weight was not associated with significant effects on any of

the haematological parameters after accounting for the effects of other factors.

3.2.3. Effects of environment factors

Pups captured whilst awake or mobile had significantly higher lymphocyte counts relative to pups that were captured whilst asleep. There was no significant difference in lymphocyte counts between awake and mobile pup captures and no other significant effects were identified for capture-type for any of the other haematological parameters. Year of sampling was associated with significant effects for all haematological parameters except for PCV, RBC, and RET. At Seal Bay, pups sampled during the summer breeding season (2012) had significantly higher neutrophil and eosinophil counts and significantly lower monocyte counts, relative to pups sampled during the winter breeding season (2010). At Dangerous Reef, pups sampled during the winter breeding season (2011) had significantly higher nRBC, lymphocyte, and eosinophil counts, and significantly lower TPP, neutrophil, and monocyte counts, relative to pups sampled during the summer breeding season (2013). Overall, pups sampled at Seal Bay had significantly higher nRBC and eosinophil counts and significantly lower TPP values and neutrophil counts compared to pups sampled at Dangerous Reef.

4. Discussion

The current study established haematological reference intervals for free-ranging neonatal Australian sea lion pups within the context of endemic hookworm infection and estimated the impact of *U. sanguinis* and *A. microchir*, and the concurrent effects of host and environment factors, on the variability of haematological parameters of pups. By investigating markers for erythroid regeneration, the current study demonstrated that anaemia in neonatal Australian sea lion pups is not solely a benign physiological response to host–environment changes, but largely reflects a significant pathological process that adversely impacts pup health with potential implications for the population demography and viability of this species.

4.1. Development of haematological reference intervals

The partitioning of neonatal Australian sea lion haematological reference intervals by hookworm infection status provides important age- and disease-specific context, enhancing their utility for future investigations. Reference intervals are generally developed by obtaining representative samples from a 'healthy' reference population, excluding subjects with clinical signs of disease that may affect the parameters of

Table 4

Final linear mixed models of the effect of host–pathogen–environment factors on the variability of neonatal Australian sea lion pup (*Neophoca cinerea*) erythrocyte parameters and total plasma protein. Presented values are the amount of variance explained by each model (R^2_m – fixed factors only; R^2_c – fixed and random factors) and the predicted regression coefficient \pm standard error for the comparative level(s) for each factor, relative to the reference level. For each model, superscript symbols indicate which comparative level coefficients were significantly different ($P < 0.05$), within each factor; values indicated in **bold** were significantly different from the reference level. Dashes indicate factors which were excluded from the final model ($P > 0.05$). P-values are presented in Table S3.

Reference level	Body condition			Hookworm infection status		Lice		Moulting		Sex		Standard length		Year of sampling							
	Comparative level	Poor	Fair	Good	Excellent	Prepatent	Patent	Postpatent	Negative	Positive	Non-moulting	Moulting	Female	Male	–	–	2010	2011	2012	2013	
Parameter	R^2_m	R^2_c																			
PCV	37%	65%	–	–	–	–0.098 ± 0.015[^]	–0.92 ± 0.20[^]	–0.092 ± 0.016[^]	–0.019 ± 0.005	–	–	–	–0.016 ± 0.005	0.018 ± 0.002	–	–	–	–	–	–	–
RBC	47%	64%	–	–	–	–0.56 ± 0.21[^]	–	–	–	–	–	–	–0.18 ± 0.06	0.23 ± 0.02	–	–	–	–	–	–	–
RET ^a	16%	26%	–	–	–	–	–	–	–	–	–2.1 ± 0.4	–	–	–0.3 ± 0.1	–	–	–	–	–	–	–
nRBC ^a	22%	32%	2.9 ± 3.7 [^]	4.1 ± 3.8 [^]	8.3 ± 4.1[^]	10.4 ± 3.7 [^]	4.1 ± 4.0 [^]	–	–	–	–	–	–	–2.6 ± 0.5	–	–	–	–	–	–	–
TPP	33%	30%	0.5 ± 2.9 [^]	2.5 ± 2.9 [^]	5.6 ± 3.2 [#]	–6.8 ± 2.9[^]	–0.9 ± 3.0 [^]	–	4.1 ± 0.9	–	–	–	–	1.1 ± 0.4	–	–	–	–	–	–	–

Abbreviations and units: see Table 1.

^a Square-root transformed.

interest (Ceriotti et al., 2009). However, few individuals in free-ranging populations are likely to be considered completely disease-free, so reference intervals developed from biased sampling of ‘healthy’ or captive individuals have little utility for free-ranging populations (Schwacke et al., 2009). For this reason, the occurrence of endemic disease in free-ranging populations should be considered when establishing baseline data to ensure reference intervals reflect the ‘normal’ characteristics of the sampled population (Pacioni et al., 2013; Hufschmid et al., 2014).

Parturition marks an extreme life-history change, necessitating adaptation to dynamic nutritional and environmental challenges and the development of immunological responses. As such, consideration of the age of sampled pups is also important to appropriately partition the reference population and interpret haematological values. However, as the extended breeding season of the Australian sea lion (Higgins, 1993; McIntosh et al., 2012) precludes the routine collection of known-age pup data or the estimation of pup age from peak parturition dates, as utilised for other otariid species (Richmond et al., 2005; Trillmich et al., 2008), the development of reference intervals for pups partitioned by known-age categories has limited clinical and conservation utility in this species. Conversely, hookworm infection status may be readily determined, is biologically meaningful, and provides a proximate measure of age as the timing of patent hookworm infection (from 11–14 days of age to approximately 2–3 months of age) effectively delimits pups into three age groups (Marcus et al., 2014a). Thus, within the context of endemic hookworm infection, the haematological reference intervals developed in the current study provide a baseline reference for the interpretation of haematological data from individual neonatal Australian sea lion pups and facilitate the monitoring of population-level health trends via changes in the temporal proportions of outliers (Lander et al., 2014; see Supplementary Table S1).

Weighted bootstrap estimation techniques were adopted in the current study to provide improved parameter estimation, facilitate the use of repeated measures data, and reduce the number of individuals required for sample collection. The traditional calculation of nonparametric reference intervals assumes sample independence; ignoring the fact that different numbers of measurements were obtained from different individuals can result in the development of incorrect reference intervals (Taylor et al., 1996). For this reason, to account for the correlation between repeated observations, weighted bootstrap estimation was used when developing nonparametric reference intervals to ensure equal contribution from individual pups whilst making efficient use of all available data (Taylor et al., 1996; Alatzas et al., 2014). Pairwise Spearman's rank correlations were estimated similarly. Alternative approaches, namely the exclusion of all but one sampling event per individual or the averaging of repeated measurements, are frequently employed in wildlife research but are relatively inefficient and can lead to the calculation of incorrect estimates (Taylor et al., 1996).

4.2. Investigation of haematological parameter variability

Determining the fundamental causes of variability in the haematological parameters of free-ranging populations is commonly confounded by the dynamic inter-related effects of pathogen, host, and environment factors (Beldomenico et al., 2008; Hufschmid et al., 2014). In the current study, haematological values and patterns of correlation differed for pups with patent or postpatent hookworm infection (Tables 1–3), yet the models attributed only part of this variation to the direct effects of hookworm infection (Tables 4 and 5). It is possible that the intensity of parasitic infection accounts for some of this variation. For example, in harbour seals (*Phoca vitulina*), the intensity of lice (*Echinophthirius horridus*) infestation was negatively correlated with PCV and RBC, however, no significant haematological differences were identified between infected and uninfected seals (Thompson et al., 1998). Similarly, hookworm infection intensity is inversely associated with growth rates of northern fur seal (*Callorhinus ursinus*), New Zealand sea lion (*Phocartos hookeri*), and Australian sea lion

Table 5
Final linear mixed models of the effect of host-pathogen-environment factors on the variability of neonatal Australian sea lion pup (*Neophoca cinerea*) leucocyte parameters. Interpretation as per Table 4.

Reference level	Body condition			Capture-type		Hookworm infection status		Lesion	Standard length	Year of sampling		
	Poor	Fair	Good	Sleeping	Awake	Prepatent	Patent			Absent	Present	2010
Comparative level										5 cm increase		
Parameter	R ² _m	R ² _c										
Neutrophils ^b	40%	51%	-	-	-	-	-	0.24 ± 0.08	-0.07 ± 0.02	0.63 ± 0.13[^]	0.41 ± 0.11[*]	0.86 ± 0.13[*]
Lymphocytes ^a	24%	33%	-	-	0.10 ± 0.05[^]	0.17 ± 0.08[^]	-	-	-0.05 ± 0.02	0.28 ± 0.09[^]	-0.03 ± 0.08[*]	-0.05 ± 0.09[*]
Monocytes ^a	30%	39%	-	-	-	-	-	-	-0.04 ± 0.01	-0.42 ± 0.05[^]	-0.15 ± 0.04[*]	0.05 ± 0.05[#]
Eosinophils ^a	42%	57%	-0.07 ± 0.14[^]	0.03 ± 0.14[*]	-	-	0.34 ± 0.14[^]	-	-0.09 ± 0.02	-0.19 ± 0.08[^]	0.15 ± 0.07[*]	-0.53 ± 0.08[#]

Abbreviations and units: see Table 1.

^a Square-root transformed.

^b Log_e transformed.

pups (Chilvers et al., 2009; DeLong et al., 2009; Marcus et al., 2014a). Hence, variance in haematological parameters related to the intensity of these parasitic infections could have been attributed to inter-related factors such as body condition, moult status, standard length, and the year of sampling, or may have contributed towards the total amount of unexplained variance in the models. In the current study, it was not possible to obtain this data as methods for determining the *in situ* intensity of hookworm infection have not been validated in pinnipeds. Conversely, the intensity of lice infestation may be determined by direct counting, although this was not undertaken in order to reduce individual pup handling time. Thus, because *U. sanguinis* and *A. microchir* infections were measured as categorical factors, their effects on haematological parameters could have been underestimated; further investigations utilising anthelmintics to prevent, reduce, or eliminate parasitic infections may help to refine estimates of their haematological effects (López-Olvera et al., 2006; Castinel, 2007). Regardless, the findings of the current study contribute towards a greater understanding of the pathogen, host, and environment factors that influence the values of haematological parameters in pinniped pups.

4.2.1. Effects of *U. sanguinis* on erythrocyte and TPP values

The presence of *U. sanguinis* infection was significantly associated with anaemia, implicating this parasite as an agent of disease and challenging assumptions about the non-pathological, physiological, nature of neonatal anaemia in pinnipeds. The pattern of anaemia observed in the current study was similar to that considered 'normal' for many pinniped species (Trillmich et al., 2008); Australian sea lion pups approximately two weeks to 2–3 months of age (that is, pups with patent hookworm infection) had lower erythrocyte values (RBC and PCV) than both younger pups with prepatent hookworm infection and older postpatent pups (Table 1). Total plasma protein values followed the same pattern, suggestive of haemorrhage. In contrast to a study of New Zealand sea lion pups in which neonatal anaemia was attributed to physiological causes rather than hookworm (*Uncinaria* sp.) infection (Castinel, 2007), the linear mixed models in the current study indicated that the erythrocyte and TPP changes in Australian sea lion pups were primarily attributable to patent hookworm infection (Table 4), suggestive of the occurrence of significant haemorrhagic anaemia. This is in agreement with earlier investigations in which infections of *Uncinaria lucasi* in northern fur seal pups and *Uncinaria lyonsi* in California sea lion (*Zalophus californianus*) pups were associated with anaemia (Olsen, 1958; Lyons et al., 2001; Kuzmina and Kuzmin, 2015).

The erythroid response to anaemia in Australian sea lion pups was characterised as regenerative for the majority of pups with hookworm infection, indicative of the presence of a pathological process leading to anaemia. In the absence of absolute reticulocyte count data, the erythrocyte changes identified in the current study could be attributed to the strong correlation of age with hookworm infection status (Fig. 1) and would not refute the hypothesis that neonatal anaemia is non-pathological, caused predominantly by physiological responses to host-environment changes. The classification of the erythroid response to anaemia aids in differentiating between pathological and physiological mechanisms; increased numbers of circulating reticulocytes are diagnostic of a regenerative erythroid response to pathological anaemia (Stockham and Scott, 2008). However, there is limited data for reticulocyte counts in pinnipeds and none from pups; in older cohorts of Australian sea lions, fewer than 1% of erythrocytes were identified as reticulocytes, indicating that a normal reticulocyte count in the Australian sea lion is expected to be less than $47.7\text{--}60.8 \times 10^9/\text{L}$ (Needham et al., 1980). As such, what constitutes an adequate reticulocytosis in pinnipeds is unknown. For this reason, guidelines recommended for dogs were applied in the current study to define a minimum regenerative threshold (reticulocyte count $> 65.0 \times 10^9/\text{L}$ indicates regeneration; Hodges and Christopher, 2011). Increased nRBC values may also be supportive of a regenerative erythroid response (Jain, 1993); in the current study, pups with patent hookworm infection had significantly higher

nRBC compared to pre-patent and postpatent pups (Tables 1 and 4). Similarly, in anaemic northern fur seal pups infected with *U. lucasi*, increased numbers of nRBC were also observed (Olsen, 1958). Reference values for nRBC have also been reported for harbour seal pups (95% interval 0–8 nRBC/100 leucocytes), harp seal pups (*Phoca groenlandica*; range 0–50 nRBC/100 leucocytes), and hooded seal pups (*Cystophora cristata*; range 1–45 nRBC/100 leucocytes) (Trumble and Castellini, 2002; Boily et al., 2006); unfortunately, significant limitations to the comparative and clinical utility of these values arise due to the paucity of absolute nRBC count data (Allison and Meinkoth, 2007) and data on health status. In Australian sea lion pups with patent hookworm infection, both RET and nRBC were significantly negatively correlated with PCV and RBC; these changes were not observed in postpatent pups. Additionally, MCV values were increased and TPP values were decreased, relative to prepatent and postpatent pups. Overall, these findings are suggestive of a macrocytic regenerative response to hookworm-associated haemorrhage, providing a causative link between hookworm infection and anaemia and further implicating *U. sanguinis* as an important agent of disease in Australian sea lion pups. Hence, the effects of hookworm infection offer an alternative – or concurrent – explanation for the occurrence of neonatal anaemia in Australian sea lion pups to the hypothesis that neonatal anaemia results from physiological responses to non-pathological host–environment changes.

4.2.2. Effects of *A. microchir* on erythrocyte and TPP values

Relative to *U. sanguinis* infection, the presence of *A. microchir* infestation was associated with a smaller decrease in PCV values, no change in RBC, RET, or nRBC values, and an increase in TPP values, indicating that *A. microchir* infestation plays a lesser role in neonatal anaemia, although may contribute towards immunological stimulation or dehydration. Incidentally, the occurrence of lice infestation in pups in the current study (crude cumulative prevalence 79.3%, CI 74.2–83.8%; see Supplementary Table S4) was significantly higher (Fisher's exact test: $P < 0.001$) than that previously reported for Australian sea lion pups (48.9%, CI 34.1–63.9%; McIntosh and Murray, 2007). Differences in methodological approach (among others the calculation of cumulative prevalence versus cross-sectional prevalence) account for the higher prevalence observed in the current study. Additionally, the crude cumulative prevalence of lice infestation of pups with patent hookworm infection (81.2%, CI 75.3–86.2%) was significantly higher (Fisher's exact test: $P = 0.029$) than for postpatent pups (68.7%, CI 57.6–78.4%). The evidence that lice can directly cause disease in free-ranging pinnipeds is limited (Thompson et al., 1998), although they are capable of acting as vectors for other pathogens (Jellison and Milner, 1958; Geraci et al., 1981; Linn et al., 2001). Heavy lice infestations can cause pruritus, alopecia, and anaemia, however, they may be acquired secondary to other disease processes causing debilitation (Dailey, 2001), such as hookworm infection. Hence, the current study indicates that *A. microchir* is associated with mild disease and is unlikely to be having a significant impact on the health status of Australian sea lion pups. Further investigation of the epidemiology of *A. microchir* in Australian sea lion pups is necessary to determine the factors that influence the prevalence and intensity of this parasite.

4.2.3. Effects of host factors on erythrocyte and TPP values

As expected, significant increases in PCV, RBC, and TPP values were associated with increases in standard length (Table 4), indicative of recovery from hookworm-associated haemorrhagic anaemia via the regenerative erythroid response and progressive 'normalisation' of haematological parameters in older pups. Additionally, increases in TPP values could be explained by increased exposure to antigenic stimuli (and therefore higher globulin values) in older pups, associated with the ontogeny of diving behaviour (Fowler et al., 2007; Brock et al., 2013). Further investigation to characterise changes in plasma protein fractions and their response to disease are required to further elucidate

the physiological and pathological mechanisms contributing towards hypo- and hyperproteinaemia (Gray et al., 2005; Schmertmann, 2010).

Pup sex had a small but significant effect on PCV and RBC values (Table 4), a difference not identified in a limited study of Australian sea lions aged 6–23 months (Fowler et al., 2007). Sex-related neonatal erythrocyte differences have been reported in one longitudinal study of Steller sea lions (*Eumetopias jubatus*) in which male pups had significantly lower RBC and significantly higher PCV than female pups, although differences were considered clinically irrelevant (Lander et al., 2014). These differences were not identified in other studies of Steller sea lion pups (Rea et al., 1998; Richmond et al., 2005) nor in investigations of other pinniped pups (Lane et al., 1972; Horning and Trillmich, 1997; Hall, 1998; Beckmen et al., 2003; Castinel, 2007; Trillmich et al., 2008). The underlying mechanisms contributing to these sex-related differences are unclear as hookworm infection intensity does not appear to significantly differ between sexes (Marcus et al., 2014a) and major sex-related differences in physiology and behaviour are not expected in pinniped pups (Greig et al., 2010).

4.2.4. Effects of pathogen and host factors on leucocyte values

Temporal changes in leucocyte parameters in Australian sea lion pups followed the same general pattern described for Steller sea lion and Galapagos sea lion (*Zalophus wollebaeki*) pups, that is, median leucocyte counts were high shortly after birth and decreased with increasing age (Keogh et al., 2010; Brock et al., 2013). This pattern likely reflects a similar developmental history in which immunologically-naïve neonates are exposed to a range of novel environmental antigens and develop endogenous immune responses, resulting in a complex series of correlations between leucocytes (Tables 2 and 3). Neutrophils were the predominant leucocyte cell-type, followed by lymphocytes, eosinophils, and monocytes, the relative proportions of which were similar across all hookworm infection status groups and approximated those reported for older cohorts of Australian sea lions (Needham et al., 1980). Consistent with previous investigations, no basophils were identified in the pup blood smears examined (Needham et al., 1980; Clark et al., 2002; Schmertmann, 2010).

The leucocyte response to hookworm infection was characterised predominantly by a systemic lymphocytosis and eosinophilia (Table 5), reflective of the small-intestinal tissue response identified histologically (Larum, 2010), and was similar to the predominantly eosinophilic response observed in humans and dogs to hookworm infection (Fujiwara et al., 2006). In contrast, lice infestation was not associated with significant effects on leucocyte parameters in the current study. The observed lymphocyte values of Australian sea lion pups with patent hookworm infection (median $3.18 \times 10^9/L$, 95% RI $1.44\text{--}5.99 \times 10^9/L$) were similar-to-less than those observed in both New Zealand sea lion pups (1–58 days of age) with *Uncinaria* sp. infection (mean $2.32 \times 10^9/L$, range $0.21\text{--}16.04 \times 10^9/L$) and Steller sea lions pups (<2 months of age) of undetermined health status (median $3.17 \times 10^9/L$, 95% RI $1.13\text{--}8.99 \times 10^9/L$) (Castinel, 2007; Lander et al., 2014). In contrast, the eosinophil values of Australian sea lion pups (median $1.13 \times 10^9/L$, 95% RI $0.05\text{--}3.54$) were markedly higher than those observed in both New Zealand sea lion pups (mean $0.05 \times 10^9/L$, range $0.00\text{--}1.46 \times 10^9/L$) and Steller sea lions pups (median $0.36 \times 10^9/L$, 95% RI $0.00\text{--}1.93 \times 10^9/L$) (Castinel, 2007; Lander et al., 2014). It is unclear whether this difference in eosinophil values is due to inherent immunological host-response differences or reflects the intensity and pathogenicity of hookworm infection in Australian sea lion pups compared to other pinniped hosts. The latter is more likely given the high intensity of infection (Marcus et al., 2014a) and marked intestinal pathology identified on histopathology sections (Larum, 2010). Interestingly, pups in better body condition tended to have higher eosinophil values (as well as higher nRBC and TPP values; see Tables 4 and 5), suggesting that eosinophilic inflammatory responses may have a protective effect as pup body condition is inversely associated with hookworm infection intensity (Marcus et al., 2014a). Further investigation to

determine whether changes in leukocyte values are associated with the intensity and severity of parasitic infections are required to assess whether these immunological-responses are advantageous or deleterious to the host, and their implications for pup survival.

4.2.5. Effects of environment factors on haematological values

The effects of capture and manual restraint on observed haematological values warrant consideration, as the physiological fight-or-flight response can result in leucocytosis, due primarily to shifts in neutrophils, lymphocytes, and monocytes from the marginal pool to the circulating pool (Stockham and Scott, 2008). Additionally, splenic contraction can increase circulating erythrocytes, falsely elevating PCV, RBC, and nRBC values (Castellini et al., 1996; Stockham and Scott, 2008). In the current study, capture-type was identified as a significant factor influencing lymphocyte values, with pups captured whilst awake or mobile demonstrating a relative lymphocytosis compared to pups captured whilst asleep, supportive of a physiological lymphocytosis. Although differential effects of capture-type were not observed for other parameters, it is likely that capture-type was a relatively insensitive proxy of physiological stress levels and that the haematological parameters of all sampled pups were influenced to some degree by the acute effects of capture and manual restraint (Castellini et al., 1996). As such, the reported reference intervals reflect the haematological values of free-ranging manually-restrained neonatal pups; comparisons with captive-animal studies or those that utilise chemical restraint must be undertaken cautiously.

Finally, the relative magnitude and direction of effects attributed to the year of sampling were aligned with seasonal fluctuations in hookworm infection intensity for some haematological parameters. For example, pups demonstrated higher eosinophil counts and lower TPP values during the high-hookworm-infection-intensity season compared to the low-hookworm-infection-intensity season at both colonies (Tables 4 and 5). However, interpretation of these results is confounded as the variance associated with seasonal changes in categorically-scored factors was likely also attributed to the year of sampling (see Section 4.2). For example, the severity of cutaneous ulcerative lesions observed in pups during the Dangerous Reef summer breeding season (2013) was markedly increased compared to the other breeding seasons (unpubl. data), yet the associated variance in haematological parameters would not have been encompassed by the binomial factor 'presence of lesions' and likely was attributed to the year of sampling (see neutrophil count, Table 5). Conversely, and contrary to expectations, year of sampling had no significant effect on PCV, RBC, and RET values (Table 4), although it is possible that these effects were attributed to standard length as fluctuations in hookworm infection intensity are also expected to impact growth rates. The collection of data from additional breeding seasons is required to clarify the role of environmental seasonality and pathogen infection intensity on haematological parameters.

5. Conclusion

This is the first study to report haematological reference intervals for free-ranging neonatal Australian sea lion pups and to describe the effects of pathogen, host, and environment factors on the variability of haematological parameters in this species. *Uncinaria stenocephala* was identified as an important agent of disease for this species, with infection in pups characterised by regenerative anaemia, hypoproteinaemia, and a predominantly lymphocytic–eosinophilic systemic inflammatory response, with effects still evident in some postpatent pups. Conversely, the effects of *A. microchir* were less apparent with infestation unlikely to impact pup health. Importantly, this study demonstrated that anaemia in neonatal Australian sea lion pups is not solely a benign physiological response to host–environment changes, but largely reflects a significant pathological process that adversely impacts pup health. Predominantly benthic foragers, Australian sea lions operate at or near

their physiological limits with limited capacity to cope with shifts in resource availability (Fowler et al., 2007; Peters et al., 2014). As such, the effects of *U. stenocephala* on the haematological values of pups might have implications for the development of foraging and diving behaviour, which would subsequently influence the independent survival of juveniles following weaning, significantly impacting the population demography and threatening the viability of this species. The haematological reference intervals developed in this study can facilitate the implementation of long-term health surveillance, which is critical for the early recognition of changes in disease impact and to inform conservation management strategies. The outcomes of this study contribute towards a greater understanding of the dynamic role of pathogen–host–environment relationships in influencing the values of haematological parameters in pinniped pups, whilst highlighting the difficulties associated with inferring cause and effect in free-ranging populations with endemic disease.

Acknowledgements

We thank the staff at Seal Bay, Department of Environment, Water and Natural Resources (DEWNR), South Australia for logistical support and field assistance, in particular Clarence Kennedy and Janet Simpson. Thank you to Tony Jones and Adam Kemp of Protec Marine, Port Lincoln, South Australia, for providing transport and logistical support for field work at Dangerous Reef. We also thank Evelyn Hall of the Faculty of Veterinary Science, The University of Sydney for statistical advice; Christine Gotsis and George Tsoukalas of the Veterinary Pathology Diagnostic Service, Faculty of Veterinary Science, The University of Sydney for laboratory assistance; volunteers and colleagues for field assistance: Liisa Ahlstrom, Loreena Butcher, Michael Edwards, Simon Goldsworthy, Claire Higgins, Janet Lackey, Zoe Larum, Theresa Li, Andrew Lowther, Rebecca McIntosh, Paul Rogers, Laura Schmettmann, Adrian Simon, Ryan Tate, Michael Terkildsen, Mark Whelan, Peter White, Sy Woon and Mariko Yata; and Paul Canfield of the Faculty of Veterinary Science, The University of Sydney for his constructive comments on the manuscript. This work was supported by the Australian Marine Mammal Centre, Department of the Environment, Australian Government (grant number 09/17). All samples were collected under the Government of South Australia Department of Environment, Water and Natural Resources Wildlife Ethics Committee approvals (3-2008 and 3-2011) and Scientific Research Permits (A25088/4-8). We also thank the anonymous referees for their comments on the manuscript.

Appendix A. Supplementary data

Supplementary data to this article can be found online at <http://dx.doi.org/10.1016/j.cbpa.2015.02.017>.

References

- Alatzas, D.G., Mylonakis, M.E., Kazakos, G.M., Kostoulas, P., Kritsepi-Konstantinou, M., Polizopoulou, Z.S., 2014. Reference values and repeatability of buccal mucosal bleeding time in healthy sedated cats. *J. Feline Med. Surg.* 16, 144–148.
- Allison, R.W., Meinkoth, J.H., 2007. Hematology without the numbers: in-clinic blood film evaluation. *Vet. Clin. N. Am. Small Anim. Pract.* 37, 245–266.
- Banish, L.D., Gilmartin, W.G., 1988. Hematology and serum chemistry of the young Hawaiian monk seal (*Monachus schauinslandi*). *J. Wildl. Dis.* 24, 225–230.
- Barnes, J., Higgins, D.P., Gray, R., 2008. Pinnipeds. In: Vogelnest, L., Woods, R. (Eds.), *Medicine of Australian Mammals*. CSIRO Publishing, Melbourne, Victoria, pp. 541–589.
- Beckmen, K.B., Blake, J.E., Ylitalo, G.M., Stott, J.L., O'Hara, T.M., 2003. Organochlorine contaminant exposure and associations with hematological and humoral immune functional assays with dam age as a factor in free-ranging northern fur seal pups (*Callorhinus ursinus*). *Mar. Pollut. Bull.* 46, 594–606.
- Beldomenico, P.M., Telfer, S., Gebert, S., Lukomski, L., Bennett, M., Begon, M., 2008. The dynamics of health in wild field vole populations: a haematological perspective. *J. Anim. Ecol.* 77, 984–997.
- Boily, F., Beaudoin, S., Measures, L.N., 2006. Hematology and serum chemistry of harp (*Phoca groenlandica*) and hooded seals (*Cystophora cristata*) during the breeding season, in the Gulf of St. Lawrence, Canada. *J. Wildl. Dis.* 42, 115–132.

- Bossart, G.D., 2011. Marine mammals as sentinel species for oceans and human health. *Vet. Pathol.* 48, 676–690.
- Brock, P.M., Hall, A.J., Goodman, S.J., Cruz, M., Acevedo-Whitehouse, K., 2013. Applying the tools of ecological immunology to conservation: a test case in the Galapagos sea lion. *Anim. Conserv.* 16, 19–31.
- Bryden, M.M., Lim, G.H.K., 1969. Blood parameters of the southern elephant seal (*Mirounga leonina*, Linn.) in relation to diving. *Comp. Biochem. Physiol.* 28, 139–148.
- Castellini, J.M., Castellini, M.A., Kretzmann, M.B., 1990. Circulatory water concentration in suckling and fasting northern elephant seal pups. *J. Comp. Physiol. B.* 160, 537–542.
- Castellini, M.A., Davis, R.W., Loughlin, T.R., Williams, T.M., 1993. Blood chemistries and body condition of Steller sea lion pups at Marmot Island, Alaska. *Mar. Mamm. Sci.* 9, 202–208.
- Castellini, J.M., Meiselman, H.J., Castellini, M.A., 1996. Understanding and interpreting hematocrit measurements in pinnipeds. *Mar. Mamm. Sci.* 12, 251–264.
- Castinel, A., 2007. Causes of Neonatal Mortality in the New Zealand Sea Lion (*Phocarctos hookeri*). (PhD Dissertation). Massey University.
- Castinel, A., Grinberg, A., Pattison, R., Duignan, P.J., Pomroy, B., Rogers, L., Wilkinson, I.S., 2007. Characterization of *Klebsiella pneumoniae* isolates from New Zealand sea lion (*Phocarctos hookeri*) pups during and after the epidemics on Enderby Island, Auckland Islands. *Vet. Microbiol.* 122, 178–184.
- Cerriotti, F., Hinzmann, R., Panteghini, M., 2009. Reference intervals: the way forward. *Ann. Clin. Biochem.* 46, 8–17.
- Chernick, M.R., 2011. *Bootstrap Methods: A Guide for Practitioners and Researchers*. 2nd ed. John Wiley & Sons, Hoboken, New Jersey.
- Chilvers, B.L., Duignan, P.J., Robertson, B.C., Castinel, A., Wilkinson, I.S., 2009. Effects of hookworms (*Uncinaria* sp.) on the early growth and survival of New Zealand sea lion (*Phocarctos hookeri*) pups. *Polar Biol.* 32, 295–302.
- Clark, P., 2004. *Haematology of Australian Mammals*. CSIRO Publishing, Collingwood, Victoria.
- Clark, P., Boardman, W.S., Duignan, P.J., 2002. Cytology of haematological cells of otariid seals indigenous to Australasian waters. *Aust. Vet. J.* 80, 161–164.
- Clark, C.A., Burns, J.M., Schreer, J.F., Hammill, M.O., 2007. A longitudinal and cross-sectional analysis of total body oxygen store development in nursing harbor seals (*Phoca vitulina*). *J. Comp. Physiol. B.* 177, 217–227.
- Cumming, G., 2009. Inference by eye: reading the overlap of independent confidence intervals. *Stat. Med.* 28, 205–220.
- Dailey, M.D., 2001. Parasitic diseases. In: Dierauf, L.A., Gulland, F.M.D. (Eds.), *CRC Handbook of Marine Mammal Medicine*, Second ed. CRC Press, Florida, pp. 357–382 (2nd edn).
- Deem, S.L., Karesch, W.B., Weisman, W., 2001. Putting theory into practice: wildlife health in conservation. *Conserv. Biol.* 15, 1224–1233.
- DeLong, R.L., Orr, A.J., Jenkinson, R.S., Lyons, E.T., 2009. Treatment of northern fur seal (*Callorhinus ursinus*) pups with ivermectin reduces hookworm-induced mortality. *Mar. Mamm. Sci.* 25, 944–948.
- Efron, B., 1982. The Jackknife, the Bootstrap and Other Resampling Plans. vol. 38. SIAM, Philadelphia.
- Fowler, S.L., Costa, D.P., Arnould, J.P.Y., Gales, N.J., Burns, J.M., 2007. Ontogeny of oxygen stores and physiological diving capability in Australian sea lions. *Funct. Ecol.* 21, 922–935.
- Fujiwara, R.T., Geiger, S.M., Bethony, J., Mendez, S., 2006. Comparative immunology of human and animal models of hookworm infection. *Parasite Immunol.* 28, 285–293.
- Geraci, J.R., 1971. Functional hematology of the harp seal *Pagophilus groenlandicus*. *Physiol. Zool.* 44, 162–170.
- Geraci, J.R., Fortin, J.F., St. Aubin, D.J., Hicks, B.D., 1981. The seal louse, *Echinophthirius horridus*: an intermediate host of the seal heartworm, *Dipetalonema spirocauda* (Nematoda). *Can. J. Zool.* 59, 1457–1459.
- Goldsworthy, S.D., McKenzie, J., Shaughnessy, P.D., McIntosh, R.R., Page, B., Campbell, R.A., 2009. An Update of the Report: Understanding the Impediments to the Growth of Australian Sea Lion Populations. SARDI Publication Number F2008/00847-1. SARDI Research Report Series No. 356 (Adelaide, Australia).
- Goldsworthy, S.D., Page, B., Lowther, A.D., Shaughnessy, P.D., 2012. Maintaining the Monitoring of Pup Production at Key Australian Sea Lion Colonies in South Australia (2010/11). SARDI Publication Number F2010/000665-2. SARDI Research Report Series No. 601 (Adelaide, Australia).
- Goldsworthy, S.D., Lowther, A.D., Shaughnessy, P.D., 2013. Maintaining the Monitoring of Pup Production at Key Australian Sea Lion Colonies in South Australia (2011/12). SARDI Publication Number F2010/000665-3. SARDI Research Report Series No. 739 (Adelaide, Australia).
- Gray, R., Canfield, P., Rogers, T., 2005. Serum proteins in the leopard seal, *Hydrurga leptonyx*, in Prydz Bay, Eastern Antarctica and the coast of NSW, Australia. *Comp. Biochem. Physiol. B* 142, 67–78.
- Greig, D.J., Gulland, F.M.D., Kreuder, C., 2005. A decade of live California sea lion (*Zalophus californianus*) strandings along the central California coast: causes and trends, 1991–2000. *Aquat. Mamm.* 31, 11–22.
- Greig, D.J., Gulland, F.M.D., Rios, C.A., Hall, A.J., 2010. Hematology and serum chemistry in stranded and wild-caught harbor seals in central California: reference intervals, predictors of survival, and parameters affecting blood variables. *J. Wildl. Dis.* 46, 1172–1184.
- Hall, A.J., 1998. Blood chemistry and hematology of gray seal (*Halichoerus grypus*) pups from birth to postweaning. *J. Zool. Wildl. Med.* 29, 401–407.
- Hall, A.J., Wells, R.S., Sweeney, J.C., Townsend, F.I., Balmer, B.C., Hohn, A.A., Rhinehart, H.L., 2007. Annual, seasonal and individual variation in hematology and clinical blood chemistry profiles in bottlenose dolphins (*Tursiops truncatus*) from Sarasota Bay, Florida. *Comp. Biochem. Physiol. A* 148, 266–277.
- Higgins, L.V., 1993. The nonannual, nonseasonal breeding cycle of the Australian sea lion, *Neophoca cinerea*. *J. Mammal.* 74, 270–274.
- Hodges, J., Christopher, M.M., 2011. Diagnostic accuracy of using erythrocyte indices and polychromasia to identify regenerative anemia in dogs. *J. Am. Vet. Med. Assoc.* 238, 1452–1458.
- Horn, P.S., Feng, L., Li, Y., Pesce, A.J., 2001. Effect of outliers and nonhealthy individuals on reference interval estimation. *Clin. Chem.* 47, 2137–2145.
- Horning, M., Trillmich, F., 1997. Development of hemoglobin, hematocrit, and erythrocyte values in Galapagos fur seals. *Mar. Mamm. Sci.* 13, 100–113.
- Hufschmid, J., Beveridge, I., Handasyde, K.A., 2014. Haematology and serum biochemistry of adult free-ranging mountain brushtail possums (*Trichosurus cunninghami*), including correlations with season, sex, age, habitat type and disease status. *Aust. J. Zool.* 61, 430–445.
- Jain, N.C., 1993. *Essentials of Veterinary Hematology*. Lea & Febiger, Philadelphia.
- Jellison, W.L., Milner, K.C., 1958. Salmonellosis (bacillary dysentery) of fur seals. *J. Wildl. Manag.* 22, 199–200.
- Keogh, M.J., Maniscalco, J.M., Atkinson, S., 2010. Steller sea lion (*Eumetopias jubatus*) pups undergo a decrease in circulating white blood cells and the ability of T cells to proliferate during early postnatal development. *Vet. Immunol. Immunopathol.* 137, 298–304.
- Kuzmina, T.A., Kuzmin, Y., 2015. Description of *Uncinaria lyonsi* n. sp. (Nematoda: Ancylostomatidae) from the California sea lion *Zalophus californianus* Lesson (Carnivora: Otariidae). *Syst. Parasitol.* 90, 165–176.
- Lahti, A., Hyltoft Petersen, P., Boyd, J.C., Rustad, P., Laake, P., Solberg, H.E., 2004. Partitioning of nongaussian-distributed biochemical reference data into subgroups. *Clin. Chem.* 50, 891–900.
- Lander, M.E., Harvey, J.T., Gulland, F.M.D., 2003. Hematology and serum chemistry comparisons between free-ranging and rehabilitated harbor seal (*Phoca vitulina richardsi*) pups. *J. Wildl. Dis.* 39, 600–609.
- Lander, M.E., Fadely, B.S., Gelatt, T.S., Rea, L.D., Loughlin, T.R., 2014. Serum chemistry reference ranges for Steller sea lion (*Eumetopias jubatus*) pups from Alaska: stock differentiation and comparisons within a North Pacific sentinel species. *EcoHealth* 10, 376–393.
- Lane, R.A.B., Morris, R.J.H., Sheedy, J.W., 1972. A haematological study of the southern elephant seal, *Mirounga leonina* (Linn.). *Comp. Biochem. Physiol.* 42, 841–850.
- Larum, Z., 2010. *Histological and Immunohistochemical Investigations of Selected Tissues of the Australian Sea Lion, Neophoca cinerea, With a Focus on Hookworm Disease*. (Honours Dissertation). The University of Sydney.
- Leonardi, M.S., Palma, R.L., 2013. Review of the systematics, biology and ecology of lice from pinnipeds and river otters (Insecta: Phthiraptera: Anoplura: Echinophthiriidae). *Zootaxa* 3630, 445–466.
- Linn, M.L., Gardner, J., Warrilow, D., Darnell, G.A., McMahon, C.R., Field, I., Hyatt, A.D., Slade, R.W., Suhrbier, A., 2001. Arbovirus of marine mammals: a new alphavirus isolated from the elephant seal louse, *Lepidophthirus macrorhini*. *J. Virol.* 75, 4103–4109.
- López-Olvera, J.R., Höfle, U., Vicente, J., Fernández-de-Mera, I.G., Gortázar, C., 2006. Effects of parasitic helminths and ivermectin treatment on clinical parameters in the European wild boar (*Sus scrofa*). *Parasitol. Res.* 98, 582–587.
- Lyons, E.T., Melin, S.R., DeLong, R.L., Orr, A.J., Gulland, F.M.D., Tolliver, S.C., 2001. Current prevalence of adult *Uncinaria* spp. in northern fur seal (*Callorhinus ursinus*) and California sea lion (*Zalophus californianus*) pups on San Miguel Island, California, with notes on the biology of these hookworms. *Vet. Parasitol.* 97, 309–318.
- Lyons, E.T., Kuzmina, T.A., Spraker, T.R., Jaggi, N., Costa, D.P., Crocker, D.E., Tift, M.S., 2012. Parasitological examination for presence of hookworms (*Uncinaria* spp.) in northern elephant seals (*Mirounga angustirostris*) at Año Nuevo State Reserve, California (2012). *Parasitol. Res.* 111, 1847–1850.
- Marcus, A.D., Higgins, D.P., Gray, R., 2014a. Epidemiology of hookworm (*Uncinaria sanguinis*) infection in free-ranging Australian sea lion (*Neophoca cinerea*) pups. *Parasitol. Res.* 113, 3341–3353.
- Marcus, A.D., Higgins, D.P., Šlapeta, J., Gray, R., 2014b. *Uncinaria sanguinis* sp. n. (Nematoda: Ancylostomatidae) from the endangered Australian sea lion, *Neophoca cinerea* (Carnivora: Otariidae). *Folia Parasitol.* 61, 255–265.
- McIntosh, R.R., Murray, M.D., 2007. Louse infestations of the Australian sea lion *Neophoca cinerea*. *Aust. Mamm.* 29, 103–106.
- McIntosh, R.R., Goldsworthy, S.D., Shaughnessy, P.D., Kennedy, C.W., Burch, P., 2012. Estimating pup production in a mammal with an extended and aseasonal breeding season, the Australian sea lion (*Neophoca cinerea*). *Wildl. Res.* 39, 137–148.
- Melin, S.R., Orr, A.J., Harris, J.D., Laake, J.L., Delong, R.L., Gulland, F.M.D., Stouffer, S., 2010. Unprecedented mortality of California sea lion pups associated with anomalous oceanographic conditions along the central California coast in 2009. *Calif. Coop. Ocean. Fish. Investig. Rep.* 51, 182–194.
- Nadler, S.A., Lyons, E.T., Pagan, C., Hyman, D., Lewis, E.E., Beckmen, K.B., Bell, C.M., Castinel, A., DeLong, R.L., Duignan, P.J., Farinpour, C., Huntington, K.B., Kuiken, T., Morgades, D., Naem, S., Norman, R., Parker, C., Ramos, P.W., Spraker, T.R., Berón-Verá, B., 2013. Molecular systematics of pinniped hookworms (Nematoda: *Uncinaria*): species delimitation, host associations and host-induced morphometric variation. *Int. J. Parasitol.* 43, 1119–1132.
- Nakagawa, S., Schielzeth, H., 2013. A general and simple method for obtaining R^2 from generalized linear mixed-effects models. *Methods Ecol. Evol.* 4, 133–142.
- Needham, D.J., Cargill, C.F., Sheriff, D., 1980. Haematology of the Australian sea lion, *Neophoca cinerea*. *J. Wildl. Dis.* 16, 103–107.
- Olsen, O.W., 1958. Hookworms, *Uncinaria lucasi* Stiles, 1901, in fur seals, *Callorhinus ursinus* (Linn.), on the Pribilof Islands. In: Trefethen, J.B. (Ed.), *Transactions of the Twenty-Third North American Wildlife Conference*, pp. 152–175 (St. Louis, Missouri, 3–5 March 1958).
- Pacioni, C., Robertson, I.D., Maxwell, M., van Weenen, J., Wayne, A.F., 2013. Hematologic characteristics of the woylie (*Bettongia penicillata ogilbyi*). *J. Wildl. Dis.* 49, 816–830.

- Peters, K.J., Ophelkeller, K., Bott, N.J., Deagle, B.E., Jarman, S.N., Goldsworthy, S.D., 2014. Fine-scale diet of the Australian sea lion (*Neophoca cinerea*) using DNA-based analysis of faeces. *Mar. Ecol.* <http://dx.doi.org/10.1111/maec.12145>.
- Rea, L.D., Castellini, M.A., Fadely, B.S., Loughlin, T.R., 1998. Health status of young Alaska Steller sea lion pups (*Eumetopias jubatus*) as indicated by blood chemistry and hematology. *Comp. Biochem. Physiol. A* 120, 617–623.
- Richmond, J.P., Burns, J.M., Rea, L.D., Mashburn, K.L., 2005. Postnatal ontogeny of erythropoietin and hematology in free-ranging Steller sea lions (*Eumetopias jubatus*). *Gen. Comp. Endocrinol.* 141, 240–247.
- Schmertmann, L., 2010. Investigating Aspects of Health and Disease in Australian Sea Lion, *Neophoca cinerea*, Pups: Haematology and Protein Analysis. (Honours Dissertation). The University of Sydney.
- Schwacke, L.H., Hall, A.J., Townsend, F.I., Wells, R.S., Hansen, L.J., Hohn, A.A., Bossart, G.D., Fair, P.A., Rowles, T.K., 2009. Hematologic and serum biochemical reference intervals for free-ranging common bottlenose dolphins (*Tursiops truncatus*) and variation in the distributions of clinicopathologic values related to geographic sampling site. *Am. J. Vet. Res.* 70, 973–985.
- Sepúlveda, M.S., Ochoa-Acuña, H., Homer, B.L., 1999. Age-related changes in hematocrit, hemoglobin, and plasma protein in Juan Fernandez fur seals (*Arctocephalus philippii*). *Mar. Mamm. Sci.* 15, 575–581.
- Sergent, N., Rogers, T., Cunningham, M., 2004. Influence of biological and ecological factors on hematological values in wild little penguins, *Eudyptula minor*. *Comp. Biochem. Physiol. A* 138, 333–339.
- Shi, R., Conrad, S.A., 2009. Correlation and regression analysis. *Ann. Allergy Asthma Immunol.* 103 (Supplement 1), S35–S41.
- Smith, K.F., Acevedo-Whitehouse, K., Pedersen, A.B., 2009. The role of infectious diseases in biological conservation. *Anim. Conserv.* 12, 1–12.
- Soto, K.H., Trites, A.W., Arias-Schreiber, M., 2004. The effects of prey availability on pup mortality and the timing of birth of South American sea lions (*Otaria flavescens*) in Peru. *J. Zool.* 264, 419–428.
- Stockham, S.L., Scott, M.A., 2008. *Fundamentals of Veterinary Clinical Pathology*. 2nd ed. Blackwell Publishing, Ames, Iowa.
- Taylor, J.M., Cumberland, W.G., Meng, X., Giorgi, J.V., 1996. Normal range estimation for repeated immunologic measures. *Clin. Diagn. Lab. Immunol.* 3, 139–142.
- Thompson, P.M., Corpe, H.M., Reid, R.J., 1998. Prevalence and intensity of the ectoparasite *Echinophthirius horridus* on harbour seals (*Phoca vitulina*): effects of host age and inter-annual variability in host food availability. *Parasitology* 117, 393–403.
- Thompson, R.C.A., Lymbery, A.J., Smith, A., 2010. Parasites, emerging disease and wildlife conservation. *Int. J. Parasitol.* 40, 1163–1170.
- Thorson, P.H., Le Boeuf, B.J., 1994. Developmental aspects of diving in northern elephant seal pups. In: Le Boeuf, B.J., Laws, R.M. (Eds.), *Elephant Seals: Population Ecology, Behavior, and Physiology*. University of California Press, Berkeley, pp. 271–289.
- Trillmich, F., Rea, L.D., Castellini, M.A., Wolf, J.B.W., 2008. Age-related changes in hematocrit in the Galápagos sea lion (*Zalophus wollebaeki*) and the Weddell seal (*Leptonychotes weddellii*). *Mar. Mamm. Sci.* 24, 303–314.
- Trumble, S.J., Castellini, M.A., 2002. Blood chemistry, hematology, and morphology of wild harbor seal pups in Alaska. *J. Wildl. Manag.* 66, 1197–1207.
- Tukey, J.W., 1977. *Exploratory Data Analysis*. Addison-Wesley Publishing Company, Reading, Massachusetts.
- Wimsatt, J., O'Shea, T.J., Ellison, L.E., Pearce, R.D., Price, V.R., 2005. Anesthesia and blood sampling of wild big brown bats (*Eptesicus fuscus*) with an assessment of impacts on survival. *J. Wildl. Dis.* 41, 87–95.

Supplementary material

Appendix S1. Additional haematological methods

S1.1 Manual versus automated counts

Erythrocyte and leucocyte counts were manually estimated from Australian sea lion blood samples ($n = 15$) using Ery-TIC and Leuko-TIC kits (Bioanalytic, Freiburg, Germany), respectively, with a Neubauer improved haemocytometer (Glaswarenfabrik Karl Hecht, Sondheim, Germany). Aliquots (150 μ l) of EDTA anti-coagulated blood samples were subsequently preserved 1:1 with Streck Cell Preservative (Streck, Omaha, USA), stored at approximately 4 °C, and analysed 2–4 days later using a Sysmex XT-2000iV automated haematology analyser (Sysmex, Kobe, Japan) at the Veterinary Pathology Diagnostic Service, Faculty of Veterinary Science, The University of Sydney. Conversion factors between haemocytometer and Sysmex counts were determined by fitting general linear models using REML estimation to the data:

$$\text{RBC}_s = 0.8447 \times \text{RBC}_h + 0.3789 \quad F_{1,13} = 45.98, P < 0.001, R^2_m = 77\%$$

$$\text{WBC}_s = 0.8373 \times \text{WBC}_h - 0.8417 \quad F_{1,13} = 1068.7, P < 0.001, R^2_m = 99\%$$

where $_s$ denotes Sysmex obtained counts and $_h$ haemocytometer counts.

Leave-one-out cross-validation model construction was also performed for each parameter with predicted Sysmex-equivalent and actual Sysmex estimates compared using two-sample paired T-tests; there were no significant differences between predicted and actual erythrocyte ($t = 0.03$, $df = 14$, $P = 0.978$) and leucocyte ($t = 0.13$, $df = 14$, $P = 0.897$) estimates.

SI.2 Equations

The following equations were used to calculate reported haematological values:

$$\text{MCV (fL)} = (\text{PCV} \times 1000) \div \text{RBC}$$

$$\text{RET} (\times 10^9/\text{L}) = \text{RBC} \times (\text{number of reticulocytes per 1000 erythrocytes})$$

$$\text{cWBC} (\times 10^9/\text{L}) = (\text{WBC} \times 100) \div ([\text{number of nucleated erythrocytes per 100 leucocytes}] + 100)$$

$$\text{Differential leucocyte* count} (\times 10^9/\text{L}) = \text{cWBC} \times (\text{proportion of leucocyte-type observed})$$

*neutrophil / lymphocyte / monocyte / eosinophil

$$\text{nRBC} (\times 10^6/\text{L}) = (\text{WBC} - \text{cWBC}) \times 1000$$

Abbreviations: cWBC – corrected leucocyte count; MCV – mean cell volume; nRBC – absolute nucleated erythrocyte count; PCV – packed cell volume; RBC – erythrocyte count; RET – absolute reticulocyte count; WBC – leucocyte count.

Supplementary tables

Table S1. The proportion of haematological values from neonatal Australian sea lion pups (*Neophoca cinerea*) identified as low and high outliers for each hookworm infection status group.

Hookworm infection status	Prepatent			Patent			Postpatent		
	n	Low outliers (%)	High outliers (%)	n	Low outliers (%)	High outliers (%)	n	Low outliers (%)	High outliers (%)
PCV	7	0.0	0.0	253	2.8	0.8	90	0.0	2.2
RBC	6	0.0	0.0	245	2.0	1.6	91	0.0	3.3
MCV	6	0.0	0.0	242	2.9	0.8	90	1.1	1.1
RET	6	0.0	0.0	243	0.0	2.9	86	0.0	1.2
nRBC	7	0.0	0.0	250	0.0	10.4	86	0.0	9.3
TPP	7	0.0	0.0	252	0.0	0.4	91	0.0	2.2
cWBC	7	0.0	0.0	250	0.0	5.2	86	0.0	4.7
Neutrophils	7	0.0	0.0	250	0.0	5.2	86	0.0	4.7
Lymphocytes	7	0.0	0.0	250	0.0	3.6	86	0.0	1.2
Monocytes	7	0.0	14.3	250	0.0	4.0	86	0.0	3.5
Eosinophils	7	0.0	0.0	250	0.0	1.6	86	0.0	4.7

Abbreviations: cWBC – corrected leucocyte count; MCV – mean cell volume; nRBC – absolute nucleated erythrocyte count; PCV – packed cell volume; RBC – erythrocyte count; RET – absolute reticulocyte count; TPP – total plasma protein.

Table S2. Combined nonparametric 95% haematological reference intervals for neonatal Australian sea lion pups (*Neophoca cinerea*) with patent and postpatent hookworm infection. Reference limits were calculated by bootstrap estimation which adjusted for repeated measures and the number of samples from each infection status group. The proportion of reference values in each group, adjusted for repeated measures, which fell outside of the reference limits are presented; proportions $\geq 4.1\%$ and $\leq 0.9\%$ (shown in **bold**) invalidate the common reference interval.

	Sample size ^a		Number of pups sampled ^a	Lower limit	Proportion below limit (%)		Upper limit	Proportion above limit (%)	
	Patent	Postpatent			Patent	Postpatent		Patent	Postpatent
PCV (L/L)	244	88	254	0.279	4.7	0.0	0.436	0.0	5.3
RBC ($\times 10^{12}/L$)	236	88	249	3.02	4.8	0.0	5.26	0.0	4.7
MCV (fL)	233	88	248	70.6	0.0	5.0	100.7	4.7	0.0
RET ($\times 10^9/L$)	236	85	321	7.6	1.1	3.8	179.6	4.7	0.0
nRBC ($\times 10^6/L$)	224	78	302	0.0	–	–	445.3	4.9	0.0
TPP (g/L)	251	89	340	54.0	4.4	0.0	87.0	1.0	1.6
cWBC ($\times 10^9/L$)	237	82	242	3.85	0.0	4.0	23.61	4.9	0.0
Neutrophils ($\times 10^9/L$)	237	82	242	1.72	0.0	5.2	17.50	4.6	0.0
Lymphocytes ($\times 10^9/L$)	241	85	246	1.11	0.5	4.2	5.65	4.4	0.0
Monocytes ($\times 10^9/L$)	240	83	240	0.00	–	–	0.90	4.8	0.0
Eosinophils ($\times 10^9/L$)	246	82	250	0.05	2.9	0.9	3.20	5.0	0.0

^a After outlier removal. Abbreviations: see Table S1.

Table S3. Significance levels (P-values) of host-pathogen-environment factors included in the final linear mixed models of neonatal Australian sea lion pup (*Neophoca cinerea*) haematological parameter variability. Dashes indicate factors which were excluded from the final models (P > 0.05).

	Body condition	Body weight	Capture	Hookworm infection status	Lesion	Lice	Moulting	Sex	Standard length	Year of sampling
PCV	–	–	–	<0.001	–	<0.001	–	0.001	<0.001	–
RBC	–	–	–	<0.001	–	–	–	0.002	<0.001	–
RET	–	–	–	–	–	–	<0.001	–	0.012	–
nRBC	0.038	–	–	<0.001	–	–	–	–	<0.001	<0.001
TPP	0.008	–	–	<0.001	–	<0.001	–	–	0.006	<0.001
Neutrophils	–	–	–	–	0.004	–	–	–	<0.001	<0.001
Lymphocytes	–	–	0.032	0.004	–	–	–	–	0.003	<0.001
Monocytes	–	–	–	–	–	–	–	–	<0.001	<0.001
Eosinophils	0.024	–	–	<0.001	–	–	–	–	<0.001	<0.001

Abbreviations: see Table S1.

Table S4. Crude prevalence of lice (*Antarctophthirus microchir*) infestation in neonatal Australian sea lion pups (*Neophoca cinerea*), partitioned by hookworm infection status. 95% confidence intervals for the crude cumulative prevalence are presented in parentheses.

Hookworm infection status	Prepatent	Patent	Postpatent	Unknown	Total
Number of pups sampled	6	213	83	33	295
Number of sampling events	7	255 ^a	91	33	386
Crude proportion of sampling events with lice (%)	71.4	78.0	64.8	60.6	73.3
Crude cumulative prevalence of lice infestation (%)	66.7 (22.3–95.7)	81.2 (75.3–86.2)	68.7 (57.6–78.4)	60.6 (42.1–77.1)	79.3 (74.2–83.8)

^a The presence of lice was not recorded at one sampling event for one pup with patent hookworm infection.

Chapter 5



Ivermectin treatment of free-ranging endangered
Australian sea lion (*Neophoca cinerea*) pups: effect on
hookworm and lice infection status, haematological
parameters, growth, and survival

Author contribution statement

This chapter was published by Springer-Verlag Berlin Heidelberg as:

Marcus AD, Higgins DP, Gray R (2015) Ivermectin treatment of free-ranging endangered Australian sea lion (*Neophoca cinerea*) pups: effect on hookworm and lice infection status, haematological parameters, growth, and survival. Parasitol Res. doi:10.1007/s00436-015-4481-4

Alan Marcus was the primary author of this publication and contributed towards all aspects including the study design, sample collection and analysis, and writing of the manuscript. Rachael Gray and Damien Higgins contributed towards the study design, sample collection, interpretation of findings, and critical revision of the manuscript.

Alan D. Marcus		Date	2/6/2015
Damien P. Higgins		Date	4/6/2015
Rachael Gray		Date	2/6/2015

Ivermectin treatment of free-ranging endangered Australian sea lion (*Neophoca cinerea*) pups: effect on hookworm and lice infection status, haematological parameters, growth, and survival

Alan D. Marcus¹ · Damien P. Higgins¹ · Rachael Gray¹

Received: 27 March 2015 / Accepted: 9 April 2015
© Springer-Verlag Berlin Heidelberg 2015

Abstract A placebo-controlled study was used to investigate the effectiveness of ivermectin to treat hookworm (*Uncinaria sanguinis*) and lice (*Antarctophthirus microchir*) infections in free-ranging Australian sea lion (*Neophoca cinerea*) pups and to test the hypotheses that these parasitic infections cause anaemia, systemic inflammatory responses, and reduced growth, and contribute towards decreased pup survival. Ivermectin was identified as an effective and safe anthelmintic in this species. Pups administered ivermectin had significantly higher erythrocyte counts and significantly lower eosinophil counts compared to controls at 1–2 months post-treatment, confirming that *U. sanguinis* and/or *A. microchir* are causatively associated with disease and demonstrating the positive effect of ivermectin treatment on clinical health parameters. Higher growth rates were not seen in ivermectin-treated pups and, unexpectedly, relatively older pups treated with ivermectin demonstrated significantly reduced growth rates when compared to matched saline-control pups. Differences in survival were not identified between treatment groups; however, this was attributed to the unexpectedly low mortality rate of recruited pups, likely due to the unintended recruitment bias towards pups >1–2 months of age for which mortality due to hookworm infection is less likely. This finding highlights the logistical and practical challenges associated with treating pups of this species shortly after birth at a remote colony. This study informs the assessment of the use of anthelmintics as a tool for the conservation management of free-ranging wildlife and outlines essential steps to further the development

of strategies to ensure the effective conservation of the Australian sea lion and its parasitic fauna.

Keywords *Antarctophthirus microchir* · Australian sea lion · Ivermectin · *Neophoca cinerea* · *Uncinaria sanguinis* · Wildlife disease

Introduction

Parasites profoundly impact the health and population dynamics of many free-ranging species (Smith et al. 2009; Thompson et al. 2010). Parasitic infection may be associated with clinical or subclinical disease, which can be evident by alterations in haematological values, changes in behaviour, and/or reduced growth rates, and can contribute directly or indirectly towards mortality (Irvine 2006; Bordes and Morand 2011). Conversely, parasites may confer an advantage to their host by stimulating development of the immune system or delaying physiologically expensive activities such as reproduction (Van Oers et al. 2002; Telfer et al. 2005). However, as ill-health can itself exacerbate parasitism, experimental manipulation of the host-parasite relationship is required to verify causal relationships and quantify the impact of parasitic infection, both of which are necessary to inform conservation management on the effectiveness of and need for control strategies (Irvine 2006; Stringer and Linklater 2014).

The Australian sea lion (*Neophoca cinerea*) is an endangered (IUCN Red List of Threatened Species; Goldsworthy and Gales 2008) and vulnerable (EPBC Act 1999) pinniped species endemic to Australia. These threatened species listings are based on the Australian sea lion's small, genetically fragmented population, population declines at some colonies, and the risk of extinction from fishery by-catch. Population recovery could be limited by their extended breeding cycle

✉ Rachael Gray
rachael.gray@sydney.edu.au

¹ Faculty of Veterinary Science, The University of Sydney, McMaster Bldg B14, Sydney, New South Wales 2006, Australia

(approximately 18 months; Higgins 1993), which reduces lifetime reproductive potential, and the low survival rate of pups to weaning (estimated range 11–44 %; McIntosh et al. 2013). Most Australian sea lion pup mortality occurs before 1–2 months of age and has been largely attributed to trauma and starvation (Higgins and Tedman 1990; McIntosh et al. 2012; McIntosh and Kennedy 2013); however, the role of infectious disease in pup mortality remains a key knowledge gap for this species (Goldsworthy et al. 2009).

The haematophagous hookworm *Uncinaria sanguinis* Marcus et al. 2014b, has recently been described in Australian sea lion pups (Marcus et al. 2014b). This parasite endemically infects 100 % of neonatal Australian sea lion pups at Dangerous Reef and Seal Bay in South Australia (Marcus et al. 2014a), two of the major breeding colonies of this species (Shaughnessy et al. 2011). Similar to *Uncinaria* spp. in other otariids, pups are likely infected via the transmammary transmission of infective larvae shortly after birth (Lyons et al. 2005; Marcus et al. 2014a). Patent small intestinal infection is evident from approximately 2 weeks of age until 2–3 months of age (Marcus et al. 2014a); the mechanism by which pups eliminate hookworm infection has not been elucidated, although may be dependent upon host immunological responses (Simpson 2014), age-related changes to the host's intestinal environment, or worm senescence. Critically, *U. sanguinis* is implicated as a cause of anaemia and hypoproteinaemia in Australian sea lion pups and infection is associated with a lymphocytic-eosinophilic systemic inflammatory response (Marcus et al. 2015). In addition, high hookworm infection intensity is associated with reduced body condition in pups and seasonal oscillations in the magnitude of colony pup mortality correspond to fluctuations in the mean intensity of hookworm infection (Marcus et al. 2014a). Thus, *U. sanguinis* is considered to be an important agent of disease for Australian sea lion pups and is hypothesised to significantly contribute towards pup mortality and demographic regulation.

Sucking lice (*Antarctophthirus microchir* Trouessart & Neumann, 1888) are also reported from Australian sea lion pups at moderate to high prevalence (49–81 %; McIntosh and Murray 2007; Marcus et al. 2015); however, as infestation is only associated with mild anaemia and hyperproteinaemia (Marcus et al. 2015), *A. microchir* is considered to have a lesser impact on pup health and population demography. The epidemiology of lice has not been thoroughly investigated in this host, although pups likely acquire infestation via close contact with conspecifics (McIntosh and Murray 2007; Leonardi et al. 2013). In contrast to hookworm infection, the intensity of lice infestation may be modified by host behaviours such as grooming.

Experimental manipulation of hookworm infection using the anthelmintic ivermectin has been reported for *Uncinaria lucasi* in northern fur seal (*Callorhinus ursinus*) pups

(Beekman 1984; DeLong et al. 2009) and for *Uncinaria* sp. in New Zealand sea lion (*Phocarctos hookeri*) pups (Castinel et al. 2007; Chilvers et al. 2009). In these hosts, ivermectin was highly effective (~96–100 %) at eliminating or preventing hookworm infection and no significant adverse effects on pup health were identified. Northern fur seal pups treated with ivermectin demonstrated significantly higher growth and survival rates relative to controls (DeLong et al. 2009). Similarly, New Zealand sea lion pups treated with ivermectin demonstrated significantly higher growth rates and a trend towards increased survival during a high mortality event associated with *Klebsiella pneumoniae* infection (Chilvers et al. 2009). Haematological parameters following ivermectin treatment were not reported in northern fur seal pups and no significant haematological differences were identified in a small study of ivermectin-treated and untreated New Zealand sea lion pups (Castinel 2007). The experimental manipulation of lice infestation with ivermectin has not been reported for free-ranging pinnipeds.

The aim of this study is to ascertain the clinical impact of hookworm and lice infections on the health of free-ranging neonatal Australian sea lion pups by experimentally manipulating naturally occurring infections. This placebo-controlled study estimates the effectiveness of ivermectin to treat *U. sanguinis* and *A. microchir* infections in pups and tests the hypotheses that these parasitic infections cause anaemia, systemic inflammatory responses, and reduced growth rates, and contribute towards decreased pup survival. The findings of this study inform the assessment of the use of anthelmintic treatment as a tool for the conservation management of this endangered species.

Materials and methods

Study site and sample collection

Field work was conducted during the consecutive 2011 'winter' breeding season (high hookworm infection intensity) and 2013 'summer' breeding season (low hookworm infection intensity) at Dangerous Reef, Spencer Gulf, South Australia (34.815° S, 136.212° E); six trips of 4–6 days duration were undertaken: in May, July, August, and September 2011 and in January and February 2013. Dangerous Reef is a remote low-lying island (approximately 250 m long and 100 m wide) with minimal vegetation and shelter; access is via sea transport and dependent upon favourable weather conditions, and time working in the colony is limited to minimise overall colony disturbance. This site is the second largest colony of the Australian sea lion, with approximate pup production of 500 pups per breeding season, and demonstrates an oscillating pattern of high (~39 %) and low (~14 %) pup mortality during winter and summer breeding seasons, respectively

(Goldsworthy et al. 2012). The extended breeding season of the Australian sea lion (approximately 7 months duration at Dangerous Reef; Goldsworthy et al. 2012), in conjunction with the limited time available in the colony, precluded the recruitment of known-aged neonatal pups on the basis of peak parturition dates or observed births, as utilised in anthelmintic studies of other otariid species (Chilvers et al. 2009; DeLong et al. 2009). Instead, pups were prospectively recruited using standard length (<80.0 cm) and moult status (non-moulting) as proximate measures of age to select pups likely to be less than 1–2 months old (McIntosh and Kennedy 2013; Marcus et al. 2014a). Pups determined retrospectively to be free of patent hookworm infection at recruitment, and hence likely to be either less than 2 weeks of age or greater than 2–3 months of age (Marcus et al. 2014a), were excluded from most statistical analyses.

Pups ($n=180$) were captured by hand or net during maternal absence and restrained manually within canvas bags. Capture type was categorised as sleeping, awake (pup alert, minimal pup exertion), or mobile (pup alert, captured after a short period of pup exertion). Pups were weighed (measured to the nearest 0.1 kg; Salter hanging scale, Avery Weigh-Tronix, West Midlands, UK), sex determined, and body condition was scored categorically (Marcus et al. 2014a). Pups were examined for the presence of clinically significant lesions (including dermatitis, cutaneous ulceration, and subcutaneous abscesses; absent/present) and lice infestation (absent/present). The number of lice present was scored (none, low, medium, or high; 0–3) for each of three areas (dorsal thorax and abdomen—‘back’, ventral abdomen—‘belly’, and ventral thorax—‘chest’) and summed to obtain a crude semi-quantified estimate of the intensity of lice infestation (scale 0–9). Faeces were collected per rectum using rayon-tipped dry swabs (Copan Diagnostics, Murrieta, USA) within a lubricated open-ended polyethylene sheath (modified 1–3 mL transfer pipette, Livingstone International, Sydney, Australia) or from the ground if pups were observed to defecate and stored at approximately 4 or -20 °C prior to analysis. Blood samples were collected from a subset of pups ($n=55$) from the brachial vein (Barnes et al. 2008) using 21-gauge \times 1-inch needles attached to 5 or 10 mL plastic syringes, transferred to 1.3 mL EDTA tubes (Sarstedt, Nümbrecht, Germany), and stored at approximately 4 °C prior to processing. To facilitate resight and recapture, pups were identified uniquely by a temporary bleach mark on their lumbosacral pelage (Schwarzkopf Nordic Blonde, Henkel Australia, Melbourne, Australia) and/or by tags applied to the trailing edge of both fore-flippers (Supertag Size 1 Small, Dalton ID, Oxfordshire, UK).

Following sample collection, pups were allocated to treatment and control groups using a randomised block design based on standard length to reduce the variability in age distribution between groups. Treated pups ($n=93$; standard length 60.0–75.0 cm, mean 67.2 ± 3.5 cm) were administered

200 μ g/kg ivermectin (10 mg/mL IVOMEC Antiparasitic Injection for Cattle, Merial Australia, Sydney, Australia) subcutaneously in the dorsal interscapular region, whilst control pups ($n=87$; standard length 60.0–75.0 cm, mean 67.0 ± 3.3 cm) were administered 0.02 mL/kg saline (0.9 % sodium chloride, Baxter Healthcare, Sydney, Australia) subcutaneously. A subset of pups ($n=40$ treatment, $n=33$ control) was re-sampled subsequently between 27 and 67 days post-treatment to assess changes in hookworm and lice infection status, haematological parameters, and growth. Resights of recruited pups were undertaken to categorise pup survival status as alive, dead (carcass positively identified), or unknown (pup not resighted; emigration or unidentified mortality). Necropsy of recruited pups found dead was performed when the degree of carcass decomposition permitted ($n=4$), in order to determine hookworm and lice infection status.

Haematological analysis

Blood samples were processed within 10 h of collection. Packed cell volume (PCV; L/L) was measured in duplicate in microhaematocrit tubes (IRIS Sample Processing, Westwood, USA) following centrifugation at 15,800 rpm for 120 s (StatSpin MP, StatSpin Technologies, Norwood, USA); mean values were utilised for statistical analysis. Total plasma protein (TPP; g/L) was measured using a hand-held refractometer (Reichert TS Meter, Cambridge Instruments, Buffalo, USA). Total erythrocyte counts (RBC; $\times 10^{12}/L$) and leucocyte counts (WBC; $\times 10^9/L$) were obtained from preserved blood samples—prepared by mixing 100–200 μ L aliquots of EDTA anti-coagulated whole blood 1:1 with Streck Cell Preservative (Streck, Omaha, USA)—using a Sysmex XT-2000iV automated haematology analyser (Sysmex, Kobe, Japan) at the Veterinary Pathology Diagnostic Service, Faculty of Veterinary Science, The University of Sydney within 9 days of blood collection (Marcus et al. 2015). Differential leucocyte counts were performed on air-dried blood smears prepared in the field that were fixed with 100 % methanol and treated with a Romanowsky-type rapid stain (Diff Quik, Lab Aids, Sydney, Australia; or Rapid Diff, Australian Biostain, Traralgon, Australia); 100 leucocytes were identified for every $10\times 10^9/L$ WBC. The proportion of nucleated erythrocytes (mainly late normoblasts) to leucocytes was also recorded to estimate absolute nucleated erythrocyte counts (nRBC; $\times 10^6/L$), corrected leucocyte counts (cWBC; $\times 10^9/L$), and absolute neutrophil, lymphocyte, monocyte, eosinophil, and basophil counts ($\times 10^9/L$). Absolute reticulocyte counts (RET; $\times 10^9/L$) were estimated by counting the number of reticulocytes per 1000 erythrocytes on air-dried smears prepared in the field by incubation of 50 μ L blood 1:1 with citrated 1 % brilliant cresyl blue (Sigma Chemical, St. Louis, USA) for 20 min and fixed with methanol for 20 s. Due to occasional samples where an insufficient volume of blood was collected to permit complete

haematological analysis, values for all haematological parameters could not be determined for every individual.

Hookworm infection status

Pup hookworm infection status was determined by examining faecal samples for hookworm eggs using a modified McMaster flotation with saturated NaCl solution or, for small faecal samples, a direct smear. Where eggs were evident, hookworm infection status was classified as 'patent'. Where eggs were not evident in faecal samples collected at recruitment ($n=14$ treatment, $n=12$ control), hookworm infection status could not be determined due to the inability to distinguish between prepatent, occult, and postpatent hookworm infection using only one faecal sample (Marcus et al. 2014a); these pups, and one control pup with no faecal sample at recruitment, were excluded from all statistical analyses except for the effectiveness of ivermectin against lice infestation. For pups with patent hookworm infection at recruitment and no eggs in their faeces at recapture, hookworm infection status was classified as 'postpatent'. Overall, 153 pups with patent hookworm infection were recruited ($n=79$ treatment, $n=74$ control) and 64 of these pups were recaptured ($n=35$ treatment, $n=29$ control; including one treatment and two control pups from which faecal samples were not obtained at recapture).

Statistical analysis

Effectiveness The effectiveness of ivermectin to treat patent hookworm infection ($n=34$ treatment, $n=27$ control) was estimated using multivariate logistic regression (MLR). The base additive model consisted of the treatment group, standard length at recruitment, and the time to recapture. The effects of prospective covariates (weight and body condition at recruitment and pup sex) on the estimation of ivermectin effectiveness were tested for significance by constructing a maximal model and covariates with the lowest explanatory power (Wald F test $P>0.05$) were removed in a backwards stepwise manner to arrive at a model that included only the base model and any significant covariates ($P<0.05$). Two-way interactions between these final model terms were tested and retained if significant ($P<0.05$). The assumption of linearity of continuous terms was accepted for correlation coefficients ≥ 0.7 of the log odds of categorised variates against their midpoint. The adjusted effectiveness and an approximate 95 % confidence interval (CI) were calculated from the final model using the formulae:

Adjusted effectiveness (%)

$$\begin{aligned} &= (1 - \text{'adjusted odds ratio'}) \times 100 \\ &= \left(1 - e^{(T-C)}\right) \times 100, \end{aligned} \quad (1)$$

$$95 \% \text{ CI } (\%) = \left(1 - e^{(T-C \pm 1.96 \times \text{SED})}\right) \times 100, \quad (2)$$

where T and C are the adjusted logit probabilities of patent hookworm infection at recapture in treatment and control pups, respectively, and SED is their standard error of difference, noting that the difference between the logits of two probabilities is the logarithm of their odds ratio. The effectiveness of ivermectin to treat and prevent lice infestation was similarly estimated for pups with known lice infestation status at both recruitment and recapture ($n=38$ treatment, $n=31$ control); the prevalence of lice at recruitment was tested for equality between treatment groups and included as an additional prospective covariate in the analysis. The difference in the intensity of lice infestation between treatment ($n=38$) and control ($n=30$) pups at recapture was assessed using general linear modelling (GLM) with REML estimation, with model construction as above. Note, that estimates of the intensity of lice infestation, which were measured on a Likert-type scale and treated as interval data, were only utilised to obtain approximate parametric comparisons of lice infestation intensity between treatment groups; the binomial covariate 'presence of lice' was used in subsequent models to avoid potentially introducing bias due to the crude semi-quantified nature of this measurement.

Haematological parameters and growth Differences in the values of haematological parameters (PCV, RBC, RET, nRBC, TPP, and differential leucocyte counts) and growth (standard length and weight) between treatment ($n=26-35$) and control ($n=22-29$) pups at recapture were assessed using GLM. Models were constructed as for effectiveness, including the following additional prospective covariates: the relevant haematological value at recruitment, the presence of lice and lesions at recruitment and recapture, hookworm infection status at recapture, and the year of sampling. Capture type at recapture was also included as a prospective covariate for haematological models to test for the physiological effects of capture on haematological parameters. The assumptions of homogeneity of residual variance and normality were checked by visually assessing the fitted value plots and histograms of residuals and, where necessary, the data was power- or log-transformed.

Survival The cumulative survival rates of treatment ($n=79$) and control ($n=74$) pups were estimated and compared using Kaplan-Meier survival analysis with the log-rank test. The maximum possible period of follow-up for each cohort of recruited pups was 139–140 days (May 2011 recruitment), 73–75 days (July 2011), 30–35 days (August 2011), and 31–35 days (January 2013), after which, pups known to be alive were censored. For pups that were identified to have died between field trips, survival time was estimated as the

known-time alive plus the median time to the next field trip. The time to censoring for pups with unknown survival was calculated similarly. To assess whether there was a significant difference in the occurrence and distribution of time to emigration or unidentified mortality between treatment groups, Kaplan-Meier survival analysis was repeated excluding pups known to have died and using unknown survival as the outcome measure. All statistical analyses were performed using GenStat 16.1 (VSN International, Hemel Hempstead, UK) and statistical significance was considered at $P < 0.05$.

Results

Effectiveness

The prevalence of patent hookworm infection at recapture 27–67 days post-treatment (MLR $\chi^2 = 32.49$, $df = 6$, $P < 0.001$; Fig. 1) was significantly different ($F = 12.63$, $df = 1$, $P < 0.001$) between treatment (2.4 %, CI 0.4–13.3 %) and control (54.0 %, CI 29.8–76.4 %) groups, after adjusting for the non-significant effects of standard length at recruitment ($F = 4.42$, $df = 3$, $P = 0.219$) and the time to recapture ($F = 5.69$, $df = 2$, $P = 0.058$). The adjusted effectiveness of ivermectin to treat patent hookworm infection was 97.9 % (CI 82.5–99.8 %).

The prevalence of lice infestation at recruitment (MLR $\chi^2 = 0.50$, $df = 4$, $P = 0.973$; Fig. 2) was not significantly different ($F = 0.03$, $df = 1$, $P = 0.862$) between treatment (73.5 %, CI 57.3–85.1 %) and control (71.6 %, CI 53.5–84.7 %) groups or across standard length ($F = 0.43$, $df = 3$, $P = 0.933$). At recapture, the prevalence of lice infestation (MLR $\chi^2 = 24.30$, $df = 5$, $P < 0.001$) was significantly associated with treatment

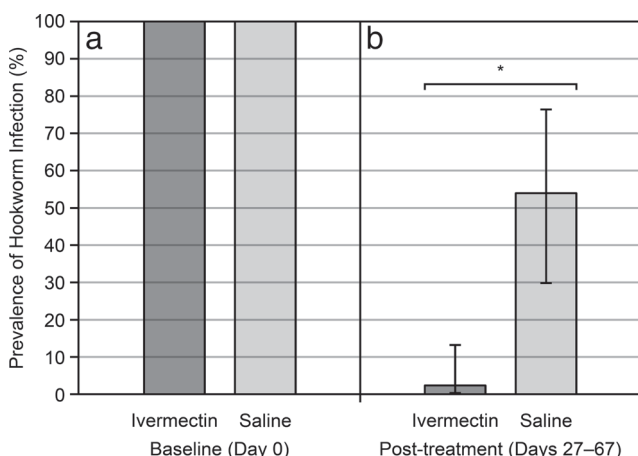

Fig. 1 The prevalence of patent hookworm (*U. sanguinis*) infection in Australian sea lion (*N. cinerea*) pups **a** before and **b** after treatment with ivermectin or saline, adjusted for the non-significant effects of standard length at recruitment and the time to recapture (27–67 days). Error bars (**b**) indicate approximate 95 % CI and the asterisk indicates significant difference ($P < 0.05$) between treatment groups

group ($F = 9.65$, $df = 1$, $P = 0.002$) and the time to recapture ($F = 7.05$, $df = 1$, $P = 0.008$), after adjusting for the non-significant effect of standard length at recruitment ($F = 4.13$, $df = 3$, $P = 0.248$). The adjusted prevalence of lice infestation at recapture 27–59 days post-treatment was significantly lower ($P < 0.05$; Fig. 2) for pups administered ivermectin (prevalence at 27 days—28.4 %, CI 12.2–53.0 %) than for pups administered saline (82.1 %, CI 53.7–94.8 %). From 60 days post-treatment, there was no significant difference in the adjusted prevalence of lice infestation between treatment groups as the prevalence for both groups approached 100 % ($P > 0.05$; Fig. 2). The adjusted effectiveness of ivermectin to treat and prevent lice infestation was 91.4 % (CI 59.6–98.2 %).

The intensity of lice infestation at recruitment (GLM $R^2 = 2$ %; Fig. 3) was not significantly different ($F_{1, 65} = 0.54$, $P = 0.463$) between treatment (mean 2.8, CI 1.9–3.6) and control (3.2, CI 2.3–4.2) groups or across standard length ($F_{1, 65} = 0.70$, $P = 0.407$). At recapture, the intensity of lice infestation (GLM $R^2 = 40$ %) was significantly associated with the interaction between treatment group and the time to recapture ($F_{1, 63} = 11.12$, $P = 0.001$), after adjusting for the non-significant effect of standard length at recruitment ($F_{1, 63} = 1.29$, $P = 0.261$). The adjusted intensity of lice infestation at recapture 27–55 days post-treatment was significantly lower ($P < 0.05$; Fig. 3) for pups administered ivermectin (mean intensity at 27 days—0.1, CI 0.0–0.9) than for pups administered saline (4.0, CI 3.0–4.9). From 56 days post-treatment, there was no significant difference in the adjusted intensity of lice infestation between treatment groups as the intensity for both groups converged to approximately 2.5 ($P > 0.05$; Fig. 3). No adverse signs associated with the administration of ivermectin were observed in the current study.

Haematological parameters

The final GLM and predicted values of haematological parameters for treatment and control pups at recapture are presented in Table 1. Pups administered ivermectin demonstrated significantly higher ($F_{1, 44} = 6.92$, $P = 0.012$) RBC values at recapture (mean $4.19 \times 10^{12}/L$, CI 4.03–4.34 $\times 10^{12}/L$) compared to pups administered saline ($3.87 \times 10^{12}/L$, CI 3.69–4.05 $\times 10^{12}/L$), after adjusting for the significant effect of RBC value at recruitment ($F_{1, 44} = 8.84$, $P = 0.005$) and the non-significant effects of standard length at recruitment ($F_{1, 44} = 1.33$, $P = 0.255$) and the time to recapture ($F_{1, 44} = 1.52$, $P = 0.225$). The final fitted model accounted for 30 % of the total variance observed in RBC values. Conversely, pups administered ivermectin demonstrated significantly lower ($F_{1, 46} = 13.67$, $P < 0.001$) absolute eosinophil counts at recapture (mean $0.17 \times 10^9/L$, CI 0.08–0.31 $\times 10^9/L$) compared to pups administered saline ($0.60 \times 10^9/L$, CI 0.43–0.80 $\times 10^9/L$), after adjusting for the significant effect of hookworm

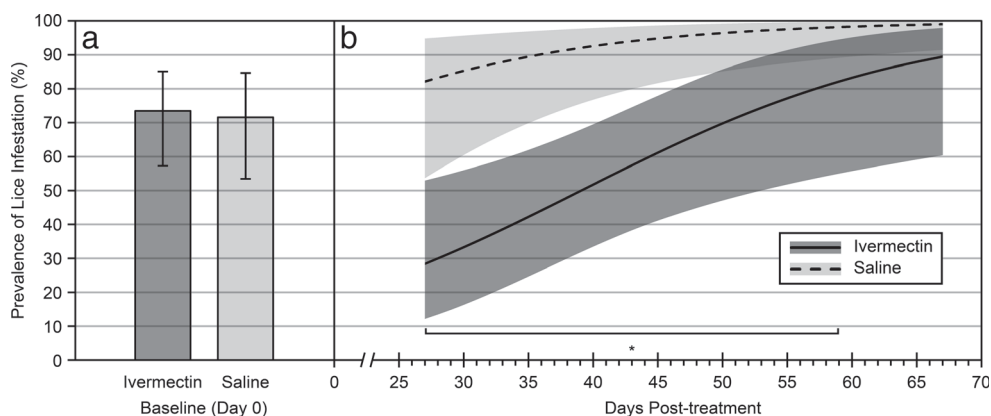

Fig. 2 The prevalence of lice (*A. microchir*) infestation in Australian sea lion (*N. cinerea*) pups **a** before and **b** 27–67 days after treatment with ivermectin or saline, adjusted for the non-significant effect of standard

length at recruitment. *Error bars* (**a**) and *shaded areas* (**b**) indicate approximate 95 % CI. The *asterisk* indicates significant difference ($P < 0.05$) between treatment groups at 27–59 days post-treatment

infection status at recapture ($F_{1, 46} = 4.56$, $P = 0.038$) and the non-significant effects of standard length at recruitment ($F_{1, 44} = 0.25$, $P = 0.621$) and the time to recapture ($F_{1, 46} = 1.44$, $P = 0.236$). Within each treatment group, the absolute eosinophil counts of pups with persistent patent hookworm infection were $0.05 \times 10^9/L$ (CI 0.0004 – $0.20 \times 10^9/L$) higher than postpatent pups. The final fitted model accounted for 44 % of the total variance observed in absolute eosinophil counts. No other significant differences between treatment and control pups were identified at recapture for the remainder of the haematological parameters measured (Table 1). Consistent with previous investigations, no basophils were identified in any of the blood smears examined (Needham et al. 1980; Clark et al. 2002; Schmetzmann 2010; Marcus et al. 2015).

Growth

The standard length of pups at recapture (GLM $R^2 = 41$ %; Fig. 4) was significantly associated with the interaction of

treatment group and standard length at recruitment ($F_{1, 43} = 6.38$, $P = 0.015$), after adjusting for the significant effect of the time to recapture ($F_{1, 43} = 5.59$, $P = 0.023$), the presence of lesions at recapture ($F_{1, 43} = 6.14$, $P = 0.017$), and the year of sampling ($F_{1, 43} = 19.92$, $P < 0.001$). Pups administered ivermectin with standard length ≥ 67.0 cm at recruitment were significantly shorter at recapture than pups administered saline ($P < 0.05$; Fig. 4); however, there was no significant difference in the standard length at recapture between treatment groups for pups with standard length < 67.0 cm at recruitment ($P > 0.05$). Within each treatment group, pups with lesions at recapture were 2.3 cm (CI 0.5–4.1 cm) shorter than pups without lesions, and pups sampled in 2011 (high hookworm infection intensity breeding season) were 5.0 cm (CI 2.8–7.2 cm) shorter at recapture than pups sampled in 2013 (low hookworm infection intensity breeding season).

The weight of pups at recapture (GLM $R^2 = 40$ %) was not significantly different ($F_{1, 59} = 0.01$, $P = 0.917$) between

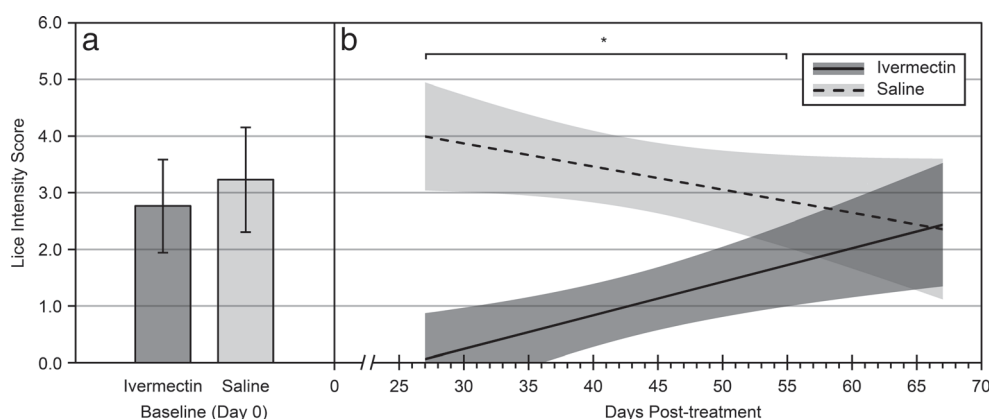

Fig. 3 The intensity of lice (*A. microchir*) infestation in Australian sea lion (*N. cinerea*) pups **a** before and **b** 27–67 days after treatment with ivermectin or saline, adjusted for the non-significant effect of standard length at recruitment. The intensity of lice was semi-quantified on a scale

of 0–9. *Error bars* (**a**) and *shaded areas* (**b**) indicate approximate 95 % CI. The *asterisk* indicates significant difference ($P < 0.05$) between treatment groups at 27–55 days post-treatment

Table 1 The predicted mean values (with 95 % confidence intervals) of haematological parameters of Australian sea lion (*N. cinerea*) pups at recapture 27–67 days after treatment with ivermectin or saline. The amount of variance explained (R^2) by the final general linear models and the P values of included terms are presented. Parameters indicated in italics were significantly different between treatment groups

Parameter	Predicted mean values		Final model							
	Ivermectin	Saline	R^2 (%)	Treatment group	Standard length at recruitment	Time to recapture	Pup sex	Haematological value at recruitment	Hookworm infection status at recapture	Year of sampling
PCV (L/L)	0.358 (0.342–0.372)	0.347 (0.329–0.363)	21	0.335	0.042	0.596	–	0.029	–	–
<i>RBC</i> ($\times 10^{12}$ /L)	<i>4.19</i> (4.03–4.34)	<i>3.87</i> (3.69–4.05)	30	0.012	0.255	0.225	–	0.005	–	–
RET ($\times 10^9$ /L)	57.0 (46.8–68.2)	67.7 (54.9–81.8)	15	0.224	0.715	0.551	0.023	–	–	–
nRBC ($\times 10^6$ /L)	30.5 (10.1–62.0)	44.8 (16.9–86.0)	1	0.517	0.789	0.619	–	–	–	–
TPP (g/L)	76.9 (74.6–79.3)	80.1 (77.4–82.8)	17	0.086	0.137	0.235	–	–	–	0.023
Neutrophils ($\times 10^9$ /L)	7.25 (6.07–8.66)	7.59 (6.23–9.25)	8	0.737	0.847	0.905	0.048	–	–	–
Lymphocytes ($\times 10^9$ /L)	2.93 (2.50–3.45)	3.44 (2.88–4.11)	7	0.204	0.404	0.250	–	–	–	–
Monocytes ($\times 10^9$ /L)	0.14 (0.09–0.21)	0.20 (0.13–0.28)	52	0.231	0.437	0.277	–	–	–	<0.001
<i>Eosinophils</i> ($\times 10^9$ /L)	<i>0.17</i> (0.08–0.31)	<i>0.60</i> (0.43–0.80)	44	<0.001	0.621	0.236	–	–	0.038	–

Abbreviations: nRBC absolute nucleated erythrocyte count, PCV packed cell volume, RBC erythrocyte count, RET absolute reticulocyte count, TPP total plasma protein

treatment (mean 10.96 kg, CI 10.36–11.55 kg) and control (10.91 kg, CI 10.25–11.56 kg) groups, after adjusting for the significant effects of the time to recapture ($F_{1, 59}=19.01$, $P<0.001$) and weight at recruitment ($F_{1, 59}=7.55$, $P=0.008$) and the non-significant effect of standard length at recruitment ($F_{1, 59}=0.15$, $P=0.701$).

Survival

The crude survival rates of treatment ($n=79$) and control ($n=74$) pups with patent hookworm infection were 93.7 and 94.6 %, respectively; four treatment and three control pups died during the 2011 breeding season and one treatment and one control pup died during the 2013 breeding season. One dead pup from each group in each breeding season was available for necropsy. These pups were all female, in poor body condition, and free of lice at necropsy. The pups administered saline were found dead approximately 18 and 56 h post-recruitment and patent small intestinal hookworm infection was confirmed. The pups administered ivermectin were found dead approximately 47 h and 32 days post-treatment: no hookworms were present in the small intestine of the 47-h pup but hookworm adults and eggs were identified in the faeces; no hookworms or eggs were present in the intestinal tract or faeces of the 32-day pup. Differential diagnoses for the cause of death in these pups include starvation and chronic hookworm infection; ivermectin toxicity or iatrogenic mortality were considered unlikely. The results of histopathological examination will be reported elsewhere. Necropsies were not performed on the five additional pups found dead due to the degree of carcass decomposition; the three pups administered ivermectin (one male and two females) were estimated to have died at approximately 22, 22, and 32 days post-treatment and the two pups administered saline (one male and one female) were estimated to have died at approximately 20 and 32 days post-recruitment.

The Kaplan-Meier cumulative survival estimates to 32 days (the time to the last observed pup death) were not significantly different (log-rank=0.065, $df=1$, $P=0.798$; Fig. 5) between treatment (93.0 %, CI 84.0–97.0 %) and control (94.4 %, CI 85.7–97.9 %) groups. However, 24.1 % of treatment pups and 23.0 % of control pups were censored due to unknown survival (emigration or unidentified mortality) before the end of the follow-up period. Additional Kaplan-Meier analysis, excluding pups known to have died, demonstrated that the occurrence and distribution of time to emigration or unidentified mortality were not significantly different between treatment groups (log-rank=0.279, $df=1$, $P=0.598$; Fig. 6): cumulative survival estimates to 122.5 days (the maximum estimated time until unknown survival status) were 37.4 % (CI 16.6–58.3 %) and 35.2 % (CI 13.8–57.6 %) for treatment and control groups, respectively.

Fig. 4 The standard length of Australian sea lion (*N. cinerea*) pups at recapture after treatment with ivermectin or saline at recruitment, adjusted for the significant effect of the time to recapture (27–67 days), the presence of lesions at recapture, and the year of sampling. Shaded areas indicate approximate 95 % CI and the asterisk indicates significant difference ($P < 0.05$) between treatment groups for pups with standard length ≥ 67.0 cm at recruitment

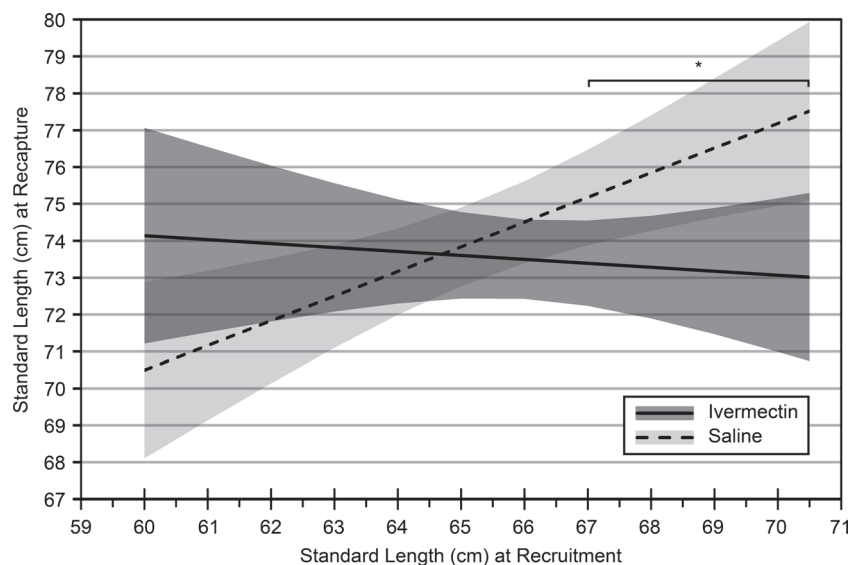

Discussion

The current study demonstrates that ivermectin is an effective and safe anthelmintic treatment for free-ranging neonatal Australian sea lion pups and confirms that hookworm and/or lice infections are causatively associated with alterations in haematological parameters, and hence disease, in this species. Differences in survival were not identified between treatment and control groups; however, this may be attributed to the unexpectedly low mortality rate of recruited pups, likely due to the unintended recruitment bias towards older pups for which mortality due to hookworm infection is less likely,

highlighting the logistical and practical challenges associated with treating pups of this species shortly after birth at a remote colony. Herein we provide recommendations for the conservation management of endemic neonatal parasitoses in this endangered species.

Effectiveness

Ivermectin was highly effective (97.9 %) at eliminating *U. sanguinis* from Australian sea lion pups, similar to that observed for *U. lucasi* in northern fur seal pups (100 %, Beekman 1984; ~96 %, DeLong et al. 2009) and *Uncinaria*

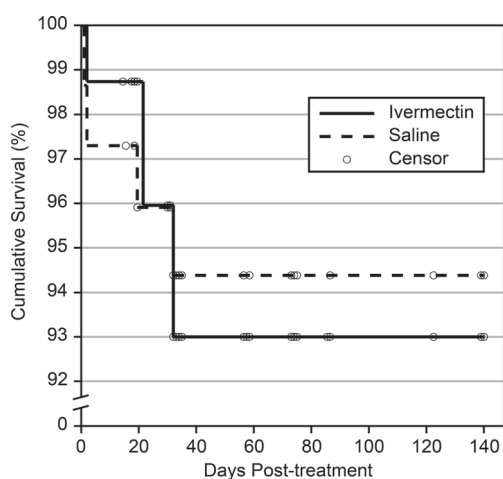

Fig. 5 Kaplan-Meier graph showing the estimated cumulative survival rate of Australian sea lion (*N. cinerea*) pups after treatment with ivermectin or saline (log-rank=0.065, $df=1$, $P=0.798$). The outcome event was confirmed pup death. Pups with unknown survival (emigration or unidentified mortality) between field trips were censored at the known-time alive plus the median time to the next field trip; otherwise, pups were censored after the maximum possible period of follow-up at 139–140 days (May 2011 recruitment), 73–75 days (July 2011), 30–35 days (August 2011), or 31–35 days (January 2013)

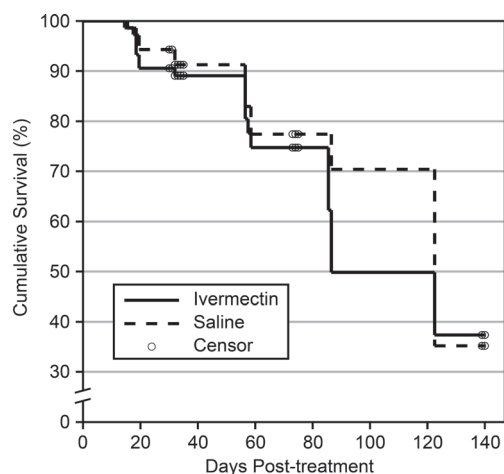

Fig. 6 Kaplan-Meier graph showing the estimated cumulative survival rate of Australian sea lion (*N. cinerea*) pups after treatment with ivermectin or saline (log-rank=0.279, $df=1$, $P=0.598$). Pups known to have died were excluded and the outcome event was unknown survival (emigration or unidentified mortality). Pups were censored after the maximum possible period of follow-up at 139–140 days (May 2011 recruitment), 73–75 days (July 2011), 30–35 days (August 2011), or 31–35 days (January 2013). This analysis demonstrates that the occurrence and distribution of time to unknown survival were not significantly different between treatment groups

sp. in New Zealand sea lion pups (100 %, Castinel et al. 2007; 100 %, Chilvers et al. 2009). Although the pharmacokinetics of ivermectin in Australian sea lion pups are unknown, adequate distribution to achieve nematocidal concentrations occurred within 2 days following subcutaneous administration, based on the elimination of hookworms from the small intestine of one treated pup found dead. This is consistent with the finding of hookworm elimination within 16 h in a northern fur seal pup following administration of ivermectin subcutaneously (DeLong et al. 2009) and the detection of maximal plasma concentrations of ivermectin and moxidectin within 4 h in juvenile stranded harbour seals (*Phoca vitulina*) following oral or subcutaneous administration, respectively (Vercruyse et al. 2003). Ivermectin was also effective (91.4 %) at removing *A. microchir* from Australian sea lion pups yet, in contrast to the apparent persistent effectiveness against hookworm infection, the prevalence and intensity of lice infestation in treated pups was equivalent to that of control pups by 2 months post-treatment (Figs. 2 and 3). These findings support hypotheses about the epidemiology of hookworm and lice infections in this host: infective hookworm larvae are transmitted to pups only via the transmammary route for a short period of time post-partum (Marcus et al. 2014a, b), whereas pups can become infected by lice from infested conspecifics at any age (McIntosh and Murray 2007). Hence, following the elimination of parasitic infections and reduction of ivermectin to non-effective concentrations, re-infection with hookworm is unlikely to occur, whereas re-infestation with lice is highly likely. To some degree, these differences may also reflect species-specific differences in their susceptibility to ivermectin and/or the development of protective host immunity against hookworm infection but not lice. Further investigation of the duration of hookworm larval excretion in milk, the role of host immunity in this species, and the pharmacokinetics of ivermectin are necessary to clarify the mechanisms contributing towards these differences.

The pattern of intensity of lice infestation in control pups—initially high then decreasing over time (Fig. 3)—may be indicative of a temporary reduction in grooming behaviour associated with the impact of patent hookworm infection, supporting the hypothesis that high intensities of lice may be secondary to other disease processes causing debilitation and act as an indicator of poor clinical health status (Dailey 2001; McIntosh and Murray 2007; Marcus et al. 2015). The intensity of lice infestation for both groups converged at approximately 2 months post-treatment (Fig. 3), corresponding to the apparent end of the period of ivermectin effectiveness as well as the natural cessation of hookworm infection for most pups (Marcus et al. 2014a), possibly reflecting the basal intensity of lice infestation. Further investigations to quantify changes in pup behaviour and lice infestation intensities are required to elucidate the factors influencing the occurrence of lice and to validate the intensity scale utilised in the current study.

Clinical impact of *U. sanguinis* and *A. microchir*

Pups administered ivermectin had significantly higher RBC values and significantly lower absolute eosinophil counts compared to saline controls at recapture (Table 1), verifying the pathological impact of *U. sanguinis* and/or *A. microchir* on the health of Australian sea lion pups. Marcus et al. (2015) identified that patent *U. sanguinis* infection was also associated with hypoproteinaemia and a lymphocytic inflammatory response in Australian sea lion pups, whilst *A. microchir* infestation was associated with hyperproteinaemia. In the current study, the TPP values and absolute lymphocyte counts of treatment and control pups were not significantly different at recapture (Table 1); however, it was not possible to differentiate between the independent effects of *U. sanguinis* and *A. microchir* in the current study because of the high effectiveness of ivermectin against both parasites. Additionally, significant differences in other haematological parameters were not identified between treatment groups at recapture, although most of the final models only explained a small proportion of the observed variance in values. Part of this unexplained variance may be due to factors not quantified in the current study such as the actual intensity of parasite infections, host genetics influencing susceptibility and response to disease, maternal experience, and short- and long-term environmental factors (Acevedo-Whitehouse et al. 2009; Lowther and Goldsworthy 2011; Marcus et al. 2015). Whilst some of these factors are difficult or impossible to quantify without long-term robust datasets, the development and validation of methods to determine the intensity of parasitic infections in live pups, along with the use of targeted parasite-specific anthelmintic treatment, should be pursued to facilitate improved estimation of the relative pathogenic effects of parasites in future studies. On balance, it is likely that *U. sanguinis* has a greater pathological impact than *A. microchir* on the health of Australian sea lion pups given that the intensity of hookworm infection (mean 2138; Marcus et al. 2014a) is up to several orders of magnitude greater than the intensity of lice infestation (“less than 5 to several 100s”; McIntosh and Murray 2007) in this host; even relatively low hookworm infection intensities are associated with the loss of large volumes of blood via gastrointestinal haemorrhage (Hotez et al. 2004), whereas sucking lice consume only small volumes of blood (Speare et al. 2006).

The association of hookworm infection with anaemia and inflammation in Australian sea lion pups is contrary to findings from a small study of New Zealand sea lion pups in which significant haematological changes were not associated with ivermectin treatment to prevent hookworm infection (Castinel 2007). Differences in methodology between studies—including sample sizes, parameters examined, and statistical approach—may account for these conflicting findings; alternatively, *U. sanguinis* may have greater pathogenicity in

N. cinerea compared to the *Uncinaria* spp. found in New Zealand sea lion pups (Marcus et al. 2015). Further investigation of the effects of parasitic infections on the haematological parameters of pups of other pinniped species is required for comparative analysis to determine the relative effects of pathogen, host, and environment factors in influencing the haematological values of pups and their impact on health status.

Unexpectedly, positive effects on growth parameters (standard length and body weight) of Australian sea lion pups administered ivermectin were not readily apparent. Instead, the only significant growth finding was that longer pups (≥ 67.0 cm at recruitment) treated with ivermectin increased in standard length at a slower rate than matched controls; no significant differences in standard length were identified between treatment groups for pups < 67.0 cm at recruitment (Fig. 4). In contrast, the weight of northern fur seal and New Zealand sea lion pups increased at significantly higher rates following ivermectin treatment compared to controls (Chilvers et al. 2009; DeLong et al. 2009); changes in standard length were not reported in these studies. An explanation for this paradoxical treatment effect in Australian sea lion pups is not clear, although similar findings have been reported uncommonly in children infected with whipworm (*Trichuris trichiura*) and treated with albendazole (Forrester et al. 1998; Tee et al. 2013). In these studies, reduced growth was only observed for children with low whipworm infection intensity that were administered a higher-than-usual dose of albendazole (800 or 1200 mg compared to 400 mg). It is possible that low nematode infection intensities have beneficial host effects, mediated via their modulation of immunological responses (Yazdanbakhsh et al. 2002). As longer pups are relatively older than shorter pups, they are in a later stage of hookworm infection and may harbour reduced hookworm infection intensity. In the current study, any potential beneficial effects from this reduced intensity may have been negated by the administration of ivermectin. Another possibility is that ivermectin has adverse effects on the physiology of Australian sea lions, as recognised for some anthelmintics in some species (Sajid et al. 2006). These adverse effects may have been evident only in older pups with reduced hookworm infection intensity if the beneficial growth effects of parasite elimination in younger pups outweighed—or were equivalent to—the negative effects of treatment; indeed, the increase in standard length of the shortest pups administered ivermectin was greater than that of control pups, although this difference was not statistically significant (Fig. 4). Finally, it should be noted that the sample size available for the growth analysis was relatively small and that these unusual findings may be attributable to a type I statistical error. Whilst the positive haematological changes associated with ivermectin treatment support the clinical impact of *U. sanguinis* and *A. microchir*, further investigation into the effects of these parasites on the growth of pups

and the effects of anthelmintics in Australian sea lion pups are warranted.

Pup survival

In order to reduce the pup mortality associated with hookworm infection, it is critical to prevent or reduce the impact of infection prior to the occurrence of significant pathology. For example, increased pup survival was associated with administration of ivermectin to northern fur seal pups at approximately 2 weeks of age and New Zealand sea lion pups at 3, 7, and 30 days of age (Chilvers et al. 2009; DeLong et al. 2009). In the current study, the apparent mortality rates of recruited pups were not significantly different between treatment and control groups and, unexpectedly, were markedly lower (5.7 % in 2011 and 6.5 % in 2013) than the estimated colony mortality rates (38.9 % in 2011 and, on the basis of historical trends, ~14 % in 2013; Goldsworthy et al. 2012). These findings suggest that despite selection criteria designed to recruit pups during the relatively early period of patent hookworm infection, recruitment was still biased towards older pups > 1 –2 months of age which are less likely to experience mortality due to hookworm infection. In addition, concurrent investigations identified that juvenile *U. sanguinis* are functionally capable of causing pathology during the prepatent period and that up to ~30 % of pup mortality occurs during this period (Marcus et al. 2014a, b). Unfortunately, given the access and temporal limitations associated with this remote colony and the extended breeding season of this species, as well as the practical, ethical, and welfare considerations of safely capturing, sampling, and treating pups whilst they are with their mate-guarded cow during the prepatent hookworm period, it was not possible in the current study to recruit these younger pups. Hence, the results of the current study are not informative about the effect of ivermectin treatment on Australian sea lion pup survival or the proportion of pup mortality which may be attributable to hookworm and lice infections.

Conservation management of endemic neonatal parasitoses: the way forward

The aim of parasite control in free-ranging wildlife populations within the context of conservation management is not to eradicate parasitic infection, but rather to lessen the impact of associated disease on the health and survival of host individuals to improve population viability; parasites are integral components of biodiverse ecosystems and should also be conserved (Gómez and Nichols 2013). Fundamentally, the benefits of parasite control to the host species and their ecosystem must outweigh the potential ecological and evolutionary costs associated with the loss or reduction of the targeted parasite and any collateral consequences (Stringer and Linklater 2014). Critically, there must be a recognised need for parasite

control; as the impact of parasitic infection on the host population's viability increases, so does the impetus to intervene (Stringer and Linklater 2014). For free-ranging neonatal Australian sea lion pups, *U. sanguinis* infection causes significant clinical health impacts and is hypothesised to contribute directly and indirectly towards considerable pup mortality, whereas *A. microchir* infestation is associated with relatively mild disease and heavy infestations may occur secondary to hookworm infection (Marcus et al. 2014a, 2015; this study). There is much uncertainty regarding the population trajectories of several of the key breeding colonies for this species yet, in contrast to the exponential growth of sympatric long-nosed fur seal (= 'New Zealand fur seal', see Shaughnessy and Goldsworthy 2014; *Arctophoca australis forsteri*) populations, Australian sea lion population growth is stagnant (Shaughnessy et al. 2013, 2014; Goldsworthy et al. 2014). It is likely that *U. sanguinis* plays a critical role in the demographic regulation of Australian sea lion populations, limiting population recovery (Marcus et al. 2014a, 2015), but further empirical evidence demonstrating the impact of *U. sanguinis* on the survival of free-ranging neonatal pups is required to demonstrate the need for parasite control. In addition, it is critical that long-term health surveillance is implemented to ensure that changes in the impact of hookworm infection, or the emergence of new diseases, are recognised early so that their effects can be mitigated. For example, there may be a need for sporadic parasite control to reduce unexpected high pup mortality, as demonstrated for New Zealand sea lion pups during high mortality epizootics associated with *K. pneumoniae* infection (Chilvers et al. 2009). However, before anthelmintic administration can be recommended as a tool for the conservation management of Australian sea lion pups it is essential to determine the long-term effects on individual health and breeding success, and the implications (if any) for the health, development, and survival of pups born to treated individuals.

Assuming that treatment directed against *U. sanguinis* is deemed necessary, it is also essential that an effective and safe treatment method can be implemented within the context-specific logistical limitations. Some of the practical and welfare considerations associated with treating Australian sea lion pups within a few days of birth could be overcome by non-invasively administering topical anthelmintic preparations to pups or pre-parturient cows (Krämer et al. 2009; Woon 2012). However, given the remote location of Dangerous Reef and the extended duration of the breeding season, it may still not be logistically feasible to treat a sufficiently large proportion of the pups born at this colony. Rather, conservation efforts could be more effective if directed towards management of other colonies which are more readily accessible and also demonstrate low pup emigration rates and high female parturition site fidelity (Higgins and Gass 1993; McIntosh et al. 2006), facilitating the short- and long-term monitoring of the individual and population effects of anthelmintic intervention.

There is concern that the treatment of free-ranging wildlife could lead to the selection for anthelmintic resistance or parasite extinction (Chilvers et al. 2009; Stringer and Linklater 2014); however, these outcomes are unlikely for *U. sanguinis* given its high genetic diversity—which does not appear to be constrained by the geographic distance between colonies or the site fidelity of breeding female sea lions (Haynes et al. 2014)—and the challenges to implementing widespread anthelmintic treatment at most remote colonies ensures a large refugia population. Ideally, whilst treatment should be directed against *U. sanguinis* infection and have no impact on *A. microchir* infestation given its much lower pathogenic effects in this species, this may not be achievable; however, the occurrence of lice on older cohorts and at other colonies likely ensures a large refugia population which can rapidly re-infest pups (Figs. 2 and 3). Further investigation of the epidemiology and genetic population structure of lice on Australian pinnipeds is required to assess the validity of these assumptions.

Finally, in order to inform conservation management, it is imperative to obtain a thorough understanding of the effects of parasitic infections on the health and disease status of individuals and to determine their role in shaping population demography. The current study contributes towards addressing these knowledge gaps and provides preliminary data that informs the assessment of the use of anthelmintics in free-ranging wildlife. For the endangered Australian sea lion, we have outlined some of the key steps that are necessary to further the development of interventional strategies to ensure the effective conservation of this species and that of its parasitic fauna.

Acknowledgements We thank Tony Jones and Adam Kemp of Protec Marine, Port Lincoln, South Australia for providing transport and logistical support for field work at Dangerous Reef. We also thank Navneet Dhand of The University of Sydney for statistical advice regarding study design; Christine Gotsis and George Tsoukalas of the Veterinary Pathology Diagnostic Service, Faculty of Veterinary Science, The University of Sydney for laboratory assistance; and volunteers and colleagues for field assistance: Simon Goldsworthy, Andrew Lowther, Paul Rogers, Laura Schmertmann, Adrian Simon, Michael Terkildsen, Mark Whelan, and Peter White. This work was supported by the Australian Marine Mammal Centre, Department of the Environment, Australian Government (grant number 09/17). All samples were collected under Government of South Australia Department of Environment, Water and Natural Resources Wildlife Ethics Committee approvals (3–2008 and 3–2011) and Scientific Research Permits (A25088/4–8).

Conflict of interest The authors declare that they have no conflict of interest.

References

- Acevedo-Whitehouse K, Petetti L, Duignan P, Castinel A (2009) Hookworm infection, anaemia and genetic variability of the New Zealand sea lion. *Proc R Soc B* 276:3523–3529. doi:10.1098/rspb.2009.1001

- Barnes J, Higgins DP, Gray R (2008) Pinnipeds. In: Vogelnest L, Woods R (eds) *Medicine of Australian mammals*. CSIRO, Melbourne, pp 541–589
- Beekman GK (1984) Clinical use of ivermectin against the hookworm (*Uncinaria lucasi*) of northern fur seal pups (*Callorhinus ursinus*). *Internat Assoc Aqua An Med (IAAAM) Proceed* 15:50
- Bordes F, Morand S (2011) The impact of multiple infections on wild animal hosts: a review. *Infect Ecol Epidemiol*. doi:10.3402/iee.v1i0.7346
- Castinel A (2007) Causes of neonatal mortality in the New Zealand sea lion (*Phocarcos Hookeri*). PhD dissertation, Massey University
- Castinel A, Duignan PJ, Lyons ET, Pomroy WE, Gibbs NJ, Lopez-Villalobos N, Chilvers BL, Wilkinson IS (2007) Epidemiology of hookworm (*Uncinaria* spp.) infection in New Zealand (Hooker's) sea lion (*Phocarcetos hookeri*) pups on Enderby Island, Auckland Islands (New Zealand) during the breeding seasons from 1999/2000 to 2004/2005. *Parasitol Res* 101:53–62. doi:10.1007/s00436-006-0453-z
- Chilvers BL, Duignan PJ, Robertson BC, Castinel A, Wilkinson IS (2009) Effects of hookworms (*Uncinaria* sp.) on the early growth and survival of New Zealand sea lion (*Phocarcetos hookeri*) pups. *Polar Biol* 32:295–302. doi:10.1007/s00300-008-0559-0
- Clark P, Boardman WS, Duignan PJ (2002) Cytology of haematological cells of otariid seals indigenous to Australasian waters. *Aust Vet J* 80:161–164. doi:10.1111/j.1751-0813.2002.tb11383.x
- Dailey MD (2001) Parasitic Diseases. In: Dierauf LA, Gulland FMD (eds) *CRC handbook of marine mammal medicine*, 2nd edn. CRC, Florida, pp 357–382
- DeLong RL, Orr AJ, Jenkinson RS, Lyons ET (2009) Treatment of northern fur seal (*Callorhinus ursinus*) pups with ivermectin reduces hookworm-induced mortality. *Mar Mamm Sci* 25:944–948. doi:10.1111/j.1748-7692.2008.00274.x
- Forrester JE, Bailar JC III, Esrey SA, José MV, Castillejos BT, Ocampo G (1998) Randomised trial of albendazole and pyrantel in symptomless trichuriasis in children. *Lancet* 352:1103–1108. doi:10.1016/s0140-6736(97)08325-6
- Goldsworthy SD, Gales NJ (2008) *Neophoca cinerea*. In: IUCN red list of threatened species. Version 2013.2. <http://www.iucnredlist.org/details/14549>. Accessed 1 May 2014
- Goldsworthy SD, McKenzie J, Shaughnessy PD, McIntosh RR, Page B, Campbell RA (2009) An update of the report: understanding the impediments to the growth of Australian sea lion populations. SARDI Publication Number F2008/00847-1. SARDI Research Report series No. 356, Adelaide, Australia
- Goldsworthy SD, Page B, Lowther AD, Shaughnessy PD (2012) Maintaining the monitoring of pup production at key Australian sea lion colonies in South Australia (2010/11). SARDI Publication Number F2010/000665-2. SARDI Research Report series No. 601, Adelaide, Australia
- Goldsworthy SD, Kennedy CW, Shaughnessy PD, Mackay AI (2014) Monitoring of Seal Bay and other pinniped populations on Kangaroo Island: 2012–2015. SARDI Publication No. F2014/000332-1. SARDI Research Report Series No. 782, Adelaide, Australia
- Gómez A, Nichols E (2013) Neglected wild life: parasitic biodiversity as a conservation target. *Int J Parasitol Parasites Wildl* 2:222–227. doi:10.1016/j.ijppaw.2013.07.002
- Haynes BT, Marcus AD, Higgins DP, Gongora J, Gray R, Šlapeta J (2014) Unexpected absence of genetic separation of a highly diverse population of hookworms from geographically isolated hosts. *Infect Genet Evol* 28:192–200. doi:10.1016/j.meegid.2014.09.022
- Higgins LV (1993) The nonannual, nonseasonal breeding cycle of the Australian sea lion, *Neophoca cinerea*. *J Mammal* 74:270–274. doi:10.2307/1382381
- Higgins LV, Gass L (1993) Birth to weaning: parturition, duration of lactation, and attendance cycles of Australian sea lions (*Neophoca cinerea*). *Can J Zool* 71:2047–2055. doi:10.1139/z93-290
- Higgins LV, Tedman RA (1990) Effect of attacks by male Australian sea lions, *Neophoca cinerea*, on mortality of pups. *J Mammal* 71:617–619. doi:10.2307/1381802
- Hotez P, Brooker S, Bethony J, Bottazzi M, Loukas A, Xiao S (2004) Hookworm infection. *N Engl J Med* 351:799–807
- Irvine RJ (2006) Parasites and the dynamics of wild mammal populations. *Anim Sci* 82:775–781. doi:10.1017/ASC2006106
- Krämer F, Epe C, Mencke N (2009) Investigations into the prevention of neonatal *Ancylostoma caninum* infections in puppies by application of imidacloprid 10 % plus moxidectin 2.5 % topical solution to the pregnant dog. *Zoonoses Public Health* 56:34–40. doi:10.1111/j.1863-2378.2008.01181.x
- Leonardi MS, Crespo EA, Raga JA, Aznar FJ (2013) Lousy mums: patterns of vertical transmission of an amphibious louse. *Parasitol Res* 112:3315–3323. doi:10.1007/s00436-013-3511-3
- Lowther AD, Goldsworthy SD (2011) Maternal strategies of the Australian sea lion (*Neophoca cinerea*) at Dangerous Reef, South Australia. *Aust J Zool* 59:54–62. doi:10.1071/ZO11025
- Lyons ET, DeLong RL, Spraker TR, Melin SR, Laake JL, Tolliver SC (2005) Seasonal prevalence and intensity of hookworms (*Uncinaria* spp.) in California sea lion (*Zalophus californianus*) pups born in 2002 on San Miguel Island, California. *Parasitol Res* 96:127–132. doi:10.1007/s00436-005-1335-5
- Marcus AD, Higgins DP, Gray R (2014a) Epidemiology of hookworm (*Uncinaria sanguinis*) infection in free-ranging Australian sea lion (*Neophoca cinerea*) pups. *Parasitol Res* 113:3341–3353. doi:10.1007/s00436-014-3997-3
- Marcus AD, Higgins DP, Šlapeta J, Gray R (2014b) *Uncinaria sanguinis* sp. n. (Nematoda: Ancylostomatidae) from the endangered Australian sea lion, *Neophoca cinerea* (Carnivora: Otariidae). *Folia Parasitol* 61:255–265. doi:10.14411/fp.2014.037
- Marcus AD, Higgins DP, Gray R (2015) Health assessment of free-ranging endangered Australian sea lion (*Neophoca cinerea*) pups: effect of haematophagous parasites on haematological parameters. *Comp Biochem Physiol A Mol Integr Physiol* 184:132–143. doi:10.1016/j.cbpa.2015.02.017
- McIntosh RR, Kennedy CW (2013) Morphology, sex ratio and cause of death in Australian sea lion (*Neophoca cinerea*) pups. *Aust Mamm* 35:93–100. doi:10.1071/AM12037
- McIntosh RR, Murray MD (2007) Louse infestations of the Australian sea lion *Neophoca cinerea*. *Aust Mamm* 29:103–106. doi:10.1071/AM07014
- McIntosh RR, Shaughnessy PD, Goldsworthy SD (2006) Mark-recapture estimates of pup production for the Australian sea lion (*Neophoca cinerea*) at Seal Bay Conservation Park, South Australia. In: Trites AW, Atkinson SK, DeMaster DP, Fritz LW, Gelatt TS, Rea LD, Wynne KM (eds) *Sea lions of the world*. Alaska Sea Grant College Program, Fairbanks, pp 353–367
- McIntosh RR, Goldsworthy SD, Shaughnessy PD, Kennedy CW, Burch P (2012) Estimating pup production in a mammal with an extended and aseasonal breeding season, the Australian sea lion (*Neophoca cinerea*). *Wildl Res* 39:137–148. doi:10.1071/WR10222
- McIntosh RR, Arthur AD, Dennis TE, Berris M, Goldsworthy SD, Shaughnessy PD, Teixeira CEP (2013) Survival estimates for the Australian sea lion: negative correlation of sea surface temperature with cohort survival to weaning. *Mar Mamm Sci* 29:84–108. doi:10.1111/j.1748-7692.2011.00558.x
- Needham DJ, Cargill CF, Sheriff D (1980) Haematology of the Australian sea lion, *Neophoca cinerea*. *J Wildl Dis* 16:103–107. doi:10.7589/0090-3558-16.1.103
- Sajid MS, Iqbal Z, Muhammad G, Iqbal MU (2006) Immunomodulatory effect of various anti-parasitics: a review. *Parasitology* 132:301–313. doi:10.1017/S0031182005009108

- Schmertmann L (2010) Investigating aspects of health and disease in Australian sea lion, *Neophoca cinerea*, pups: haematology and protein analysis. Honours dissertation, The University of Sydney
- Shaughnessy PD, Goldsworthy SD (2014) Long-nosed fur seal: a new vernacular name for the fur seal, *Arctocephalus forsteri*, in Australia. Mar Mamm Sci. doi:10.1111/mms.12203
- Shaughnessy PD, Goldsworthy SD, Hamer DJ, Page B, McIntosh RR (2011) Australian sea lions *Neophoca cinerea* at colonies in South Australia: distribution and abundance, 2004 to 2008. Endanger Species Res 13:87–98. doi:10.3354/esr00317
- Shaughnessy PD, Goldsworthy SD, Burch P, Dennis TE (2013) Pup numbers of the Australian sea lion (*Neophoca cinerea*) at The Pages Islands, South Australia, over two decades. Aust J Zool: 112–118. doi:10.1071/ZO13015
- Shaughnessy PD, Goldsworthy SD, Mackay AI (2014) Status and trends in abundance of New Zealand fur seal populations in South Australia. SARDI Publication No. F2014/000338-1. SARDI Research Report Series No. 781, Adelaide, Australia
- Simpson K (2014) Acute phase proteins and maternally and actively acquired IgG in Australian sea lion (*Neophoca cinerea*) pups with hookworm (*Uncinaria sanguinis*) infection. Honours dissertation, The University of Sydney
- Smith KF, Acevedo-Whitehouse K, Pedersen AB (2009) The role of infectious diseases in biological conservation. Anim Conserv 12: 1–12. doi:10.1111/j.1469-1795.2008.00228.x
- Speare R, Canyon DV, Melrose W (2006) Quantification of blood intake of the head louse: *Pediculus humanus capitis*. Int J Dermatol 45: 543–546. doi:10.1111/j.1365-4632.2005.02520.x
- Stringer AP, Linklater W (2014) Everything in moderation: principles of parasite control for wildlife conservation. Bioscience 64:932–937. doi:10.1093/biosci/biu135
- Tee MH, Lee YY, Majid NA, Noori NM, Raj SM (2013) Growth reduction among primary school-children with light trichuriasis in Malaysia treated with albendazole. Southeast Asian J Trop Med Public Health 44:19–24
- Telfer S, Bennett M, Bown K, Carslake D, Cavanagh R, Hazel S, Jones T, Begon M (2005) Infection with cowpox virus decreases female maturation rates in wild populations of woodland rodents. Oikos 109: 317–322. doi:10.1111/j.0030-1299.2005.13734.x
- Thompson RCA, Lymbery AJ, Smith A (2010) Parasites, emerging disease and wildlife conservation. Int J Parasitol 40:1163–1170. doi:10.1016/j.ijpara.2010.04.009
- Van Oers K, Heg D, Le Drean Quenec'hdu S (2002) Anthelmintic treatment negatively affects chick survival in the Eurasian Oystercatcher *Haematopus ostralegus*. Ibis 144:509–517. doi:10.1046/j.1474-919X.2002.00078.x
- Vercruysse J, Salomez A, Ulloa A, Osterhaus A, Kuiken T, Alvinerie M (2003) Efficacy of ivermectin and moxidectin against *Otostrongylus circumlitus* and *Parafilaroides gymnurus* in harbour seals (*Phoca vitulina*). Vet Rec 152:130–134. doi:10.1136/vr.152.5.130
- Woon S (2012) Transdermal penetration of avermectins in Australian sea lion (*Neophoca cinerea*) pups. Honours dissertation, The University of Sydney
- Yazdanbakhsh M, Kremsner PG, van Ree R (2002) Allergy, parasites, and the hygiene hypothesis. Science 296:490–494. doi:10.1126/science.296.5567.490

Chapter 6

Discussion

Chapter 6 Discussion

6.1 General discussion, limitations, and directions for future research

Understanding the effects of parasitic infection in free-ranging species, and the fundamental factors influencing the epidemiology of disease, is essential to quantifying the impact of parasites on population health and dynamics and to determine the need for, and approach to, control strategies to conserve complex biodiverse ecosystems. For the Australian sea lion, an endangered keystone predator that demonstrates high rates of pup mortality and limited population recovery, the impact of disease on pup health is a key knowledge gap (Goldsworthy et al. 2009a; Australian Government 2013a and 2013b; McIntosh and Kennedy 2013). Prior to the work presented in this thesis, the published data available on hookworm infection in the Australian sea lion was limited to reports of *Uncinaria* specimens in pups born at Seal Bay and Dangerous Reef and the finding that one hookworm specimen from Dangerous Reef was molecularly distinct from North American pinniped hookworms (Beveridge 2002; Ladds 2009; Ramos et al. 2013). This thesis investigated the hypothesis that hookworm infection is a significant cause of disease and mortality in Australian sea lion pups; the publications presented in this thesis address some of the key knowledge gaps pertaining to the taxonomy, epidemiology, clinical impact, and management of hookworm infection in this species, collectively demonstrating that *Uncinaria sanguinis* is an important agent of disease. This body of work significantly improves the understanding of hookworm infection in the Australian sea lion and contributes towards furthering the fields of parasitology and marine mammal health. The findings of this thesis inform the conservation management of this endangered species and have implications for the assessment of the effects of disease on the health status of other pinnipeds.

The findings presented in Chapter 2 indicate that a single, hitherto undescribed species of hookworm parasitises Australian sea lion pups at Seal Bay, Dangerous Reef, and The Pages Islands, extending the known range of hookworm infection in this host to include all three major breeding colonies. Based on morphological and molecular data from a relatively large number of specimens, this hookworm was described as a novel species (*U. sanguinis*) and its phylogenetic position with respect to several other pinniped hookworms was resolved. Subsequent investigations of the population structure of *U. sanguinis* demonstrated unexpectedly high levels of genetic interchange between these Australian sea lion colonies, indicating an effectively panmictic hookworm population (Haynes et al. 2014). Further investigation is necessary to determine the mechanisms by which *U. sanguinis* achieves intercolony gene flow despite the high degree of natal site fidelity of its host (Higgins and Gass 1993; Campbell et al. 2008a; Lowther et al. 2012), its transmammary mode of transmission (Chapters 2, 3, and 5), and the apparent occurrence of patent hookworm infection only in pups (Chapter 3; H. Shi, pers. comm.), which demonstrate limited dispersal capacity. In addition, whether *U. sanguinis* demonstrates host-specificity or is capable of infecting other hosts – such as the long-nosed fur seal, which could act as a vector host connecting otherwise isolated populations – is unknown and requires further investigation (Ramos et al. 2013).

Chapter 2 of this thesis reported the occurrence of substantial inter-host morphometric variation in both juvenile and adult specimens of *U. sanguinis*, in part related to host age, and therefore parasite age, highlighting the importance of examining specimens from multiple host-individuals across a range of ages in order to assess the extent of intra-species variation. This finding, together with the identification of host-specific morphometric differences for *U. hamiltoni* in the South American sea lion and South American fur seal (George-Nascimento et al. 1992) and for *U. lucasi* in the northern

fur seal and Steller sea lion (Olsen 1952, cited in Lyons 2005; Nadler et al. 2013), demonstrates the limited utility of quantitative morphometrics to discriminate between different *Uncinaria* species and engenders caution when delimiting new species. As utilised in this study, coupling traditional morphological analysis and molecular techniques improves species descriptions and the certainty of identification (Pérez-Ponce de León and Nadler 2010). This is important because knowledge of species identity is essential for the comprehensive investigation of host-parasite-environment relationships and to attribute pathological changes to the correct agent of disease, which is critical for informing the conservation management of parasites and their hosts (Thompson et al. 2010). By determining that a single species of hookworm parasitises Australian sea lion pups, the findings of Chapter 2 established the foundation for subsequent chapters in this thesis to investigate the epidemiology, clinical impact, and management of this parasite.

The findings of this thesis support the hypothesis that the transmammary transmission of hookworm larvae to neonatal pups is the predominant route leading to patent hookworm infection in otariids. This has been most convincingly demonstrated for *U. lucasi* in the northern fur seal (Lyons et al. 2011b) and is also supported by studies in the Juan Fernandez fur seal, California sea lion, and New Zealand sea lion (Sepúlveda and Alcaíno 1993; Lyons et al. 2003; Castinel et al. 2007a). Evidence implicating transmammary transmission in the immediate post-parturient period as the predominant – and possibly exclusive – route leading to patent *U. sanguinis* infection in Australian sea lion pups was presented in Chapters 2, 3, and 5:

- i. the absence of hookworm infection in stillborn pups or pups that have not suckled, indicating that hookworm infection is not acquired *in utero*;
- ii. the little intra-host variation in the size of hookworm specimens, indicating that pups acquire hookworm infection over a relatively short period of time;

- iii. the short duration of overlap between the end of the prepatent period and the start of patent infection, indicating that the timing of hookworm infection is similar for all pups;
- iv. the occurrence of hookworm infection in pups from 6 days of age across a range of substrate types, indicating that colony substrate is unlikely to be the primary source of infective hookworm larvae; and
- v. the apparent absence of re-infection subsequent to natural or anthelmintic-mediated elimination of infection, indicating that infective hookworm larvae are likely only transmitted to pups for a short period of time post-partum.

Overall, these findings exclude alternative pathways of infection as the predominant route by which Australian sea lion pups acquire patent *U. sanguinis* infection; the acquisition of infection via the ingestion of an intermediate or paratenic host, or via orally or percutaneously acquired free-living larvae, as occurs for other hookworm species in other hosts, cannot be excluded as possible routes of patent hookworm infection, although given the available evidence, they do not contribute significantly towards the intensity of hookworm infection in pups. In order to confirm the life cycle of *U. sanguinis* in the Australian sea lion, further investigation is required to demonstrate the occurrence of tissue-stage hookworm larvae and their excretion in milk. In addition, the current understanding of the hookworm life cycle in pinnipeds raises several key questions regarding the regulatory role of host immunity: What are the control mechanisms of hookworm larval hypobiosis and reactivation? Are tissue-stage larvae able to migrate to, and develop into adult hookworms in, the intestinal tract? Are hookworm larvae only transmitted via the transmammary route for a short period of time or are only neonatal pups susceptible to infection? Is elimination of hookworm infection dependent upon host immunological responses, age-related changes to the host's intestinal environment, or

worm senescence? Further research to address these questions will improve our understanding of the host-parasite-environment relationship which could have implications for the conservation management of free-ranging pinnipeds as well as the control of hookworm infection in other hosts, including humans.

The results of investigations into the prevalence and intensity of *U. sanguinis* in free-ranging Australian sea lion pups (Chapter 3) provide essential baseline data on the epidemiology of this significant agent of disease and contribute a new perspective to understanding the fundamental factors that influence the dynamics of hookworm infection in otariids. The prepatent period of *U. sanguinis* in Australian sea lion pups was determined to be 11–14 days, similar to that determined for *U. lucasi* in northern fur seal pups, whilst the duration of patent hookworm infection (approximately 2–3 months) was found to be intermediate to that observed in northern fur seal pups (approximately 6–8 weeks) and in South American fur seal, South American sea lion, and California sea lion pups (approximately 6–8 months) (Lyons et al. 2000a; Lyons et al. 2011b; Hernández-Orts et al. 2012; Katz et al. 2012). In other otariid species, greater hookworm infection prevalence and intensity are associated with sandy substrates over rocky substrates (Sepúlveda 1998; Lyons et al. 2000b; Lyons et al. 2005; Ramos 2013), similar to the predominant substrate types of Seal Bay and Dangerous Reef, respectively; however, contrary to expectations, there were no significant differences in the overall prevalence and intensity of hookworm infection between Seal Bay and Dangerous Reef. Rather, this study identified that the endemic occurrence of *U. sanguinis* is effectively 100 % in Australian sea lion pups born at both Seal Bay and Dangerous Reef and that the intensity of hookworm infection (mean intensity of 2138 hookworms per pup), which is substantially greater than that reported in other otariid hosts (see Chapter 1, section 1.3.3 for comparative values), appears to be influenced by seasonally-dependent biogeography

(Chapter 3). At Seal Bay, high hookworm infection intensity was associated with the summer breeding season (mean 2165 hookworms per pup) and low hookworm infection intensity was associated with the winter breeding season (mean 745 hookworms per pup), whereas the opposite seasonal association was identified at Dangerous Reef (winter, mean 1927 hookworms per pup; summer, mean 67 hookworms per pup). These findings indicate that the substrate type and the long-term survival of free-living larvae are unlikely to be critical factors that significantly influence the epidemiology of hookworm infection in Australian sea lion pups. Instead, it is hypothesised that the extended duration of the breeding season and the minimum duration of patent hookworm infection in pups, both of which help to ensure that free-living larvae are present in the colony for at least six months each breeding cycle, account for the high prevalence of hookworm infection irrespective of colony substrate type. In addition, colony-specific seasonal differences in host behaviour, which influences local host aggregation, are hypothesised to influence the degree of exposure to free-living hookworm larvae, accounting for the seasonal fluctuations in hookworm infection intensity. Further investigation of the prevalence and intensity of hookworm infection at Seal Bay and Dangerous Reef during additional breeding seasons, as well as at other Australian sea lion colonies, is required to verify and improve our understanding of the host-pathogen-environment relationships that influence the epidemiology of hookworm infection in this host; given the logistical constraints associated with accessing other colonies, such as The Pages Islands, and the temporal and financial limits of this project, the investigation of hookworm infection at other colonies was beyond the scope of this thesis. However, the results presented here provide a solid foundation upon which researchers and conservation managers can monitor changes in the occurrence of hookworm infection at Seal Bay and Dangerous Reef in association with changes in population demography. More broadly, application of the methodology utilised

in this study to investigations in other free-ranging species, in particular the implementation of repeated temporal sampling, could improve the accuracy of estimates of pathogen occurrence and facilitate comparative studies to elucidate the fundamental factors influencing the epidemiology of infectious diseases across a range of hosts and environments.

Another significant contribution of this thesis is to improving the understanding of the impact of infectious disease on Australian sea lion health and its role in shaping population demography. The publications presented in this thesis relate the dynamics of *U. sanguinis* infection to the occurrence of seasonal patterns in clinical health parameters and pup mortality, and demonstrate the causative link between this parasite and disease in pups by quantifying the impact of infection on clinical health parameters and verifying this association via experimental manipulation. The intensity of hookworm infection has been implicated in other otariid hosts as a major factor that determines the severity of associated disease and subsequent mortality of pups (Olsen 1958; Keyes 1965; Lyons et al. 1997; Mizuno 1997; Sepúlveda 1998; Lyons et al. 2001; Berón-Vera et al. 2004; Lyons et al. 2005; Castinel et al. 2007a; Chilvers et al. 2009; DeLong et al. 2009; Hernández-Orts et al. 2012; Ramos 2013; Seguel et al. 2013a). In the Australian sea lion, evidence indicating that hookworm infection causes intensity-dependent disease in pups is provided by the findings, presented in Chapters 3 and 4, that higher hookworm infection intensity was significantly associated with reduced pup body condition and breeding seasons in which higher colony pup mortality occurred; that the relative age of dead pups during high hookworm infection intensity seasons was decreased compared to those which died during low hookworm infection intensity seasons; and that pups demonstrated higher eosinophil counts and lower total plasma protein values during high hookworm infection intensity seasons compared to low hookworm infection intensity seasons at both colonies. In

addition, pups sampled during the summer breeding season at Dangerous Reef, which had the lowest hookworm infection intensity determined across the four breeding seasons in this study, demonstrated a significantly increased prevalence of patent hookworm infection and an apparent delay in the onset of moult, suggestive of increased growth rates due to less-severe disease impact.

Further evidence demonstrating the causative link between *U. sanguinis* and disease in Australian sea lion pups is provided by the findings of Chapter 4, which estimated the effect of hookworm infection on the health status of pups by the assessment of changes in haematological parameters. Prior to this study, published data on the haematological parameters of Australian sea lion pups younger than six months of age was lacking and the effects of disease on haematological values in this species had not been reported. Therefore, to facilitate health assessment, haematological reference intervals were developed for free-ranging neonatal Australian sea lion pups within the context of endemic hookworm infection. These reference intervals demonstrated that the distributions of haematological values for all measured parameters were significantly different between neonatal pups with patent hookworm infection and older postpatent pups; pups with patent hookworm infection demonstrated relative macrocytic anaemia, hypoproteinaemia, and leucocytosis in comparison to postpatent pups. These findings are similar to the ‘normal’ developmental patterns observed in other pinniped species, however, in contrast to previous studies, the erythroid response to anaemia was characterised by quantifying the number of circulating reticulocytes and nucleated erythrocytes, thereby facilitating differentiation between the predominant underlying pathological or physiological mechanisms leading to anaemia (Stockham and Scott 2008). Critically, for the majority of pups with patent hookworm infection, the erythroid response was characterised as regenerative, indicative of the presence of a pathological process leading to anaemia,

whilst the concurrent occurrence of hypoproteinaemia indicated that this process was likely haemorrhagic in nature, implicating *U. sanguinis* as the causative factor. In addition, the systemic lymphocytosis and eosinophilia observed in pups with patent hookworm infection, which was similar to the small-intestinal tissue response to hookworm infection identified histologically (Larum 2010; R. Gray, pers. comm.), was predominantly attributed to the occurrence of *U. sanguinis*. Interestingly, the degree of eosinophilia observed in this study was markedly higher than that observed in other otariid pups (Castinel 2007; Lander et al. 2014), possibly reflective of the higher intensity and pathogenicity of hookworm infection in Australian sea lion pups. Overall, these findings demonstrate the significant adverse impact that *U. sanguinis* has on the health status of Australian sea lion pups and, by demonstrating that the occurrence of neonatal anaemia is not solely a benign physiological response to host-environment changes in this species, challenges assumptions about the non-pathological nature of neonatal anaemia in other pinnipeds.

The focus of this thesis was on hookworm infection in Australian sea lion pups, yet other pathogens could also have significantly influenced the health status of sampled pups, potentially confounding the interpretation of the haematological effects of *U. sanguinis*. Data on the occurrence and effects of other infectious disease agents in the Australian sea lion is limited (see Chapter 1, Table 1) and the scope of this study did not extend to investigate the possibility of disease due to microscopic pathogens such as bacteria, fungi, protozoa, or viruses; however, concurrent histopathological studies either did not identify these pathogens or did not implicate them as contributing significantly to disease in pups (Larum 2010; R. Gray, pers. comm.). In this study, *U. sanguinis* was the only macroparasite identified in the gastrointestinal tract of pups; the absence of other macroscopic gastrointestinal parasites is probably due to the relatively young age of pups

sampled and the likely requirement of the ingestion of an intermediate host for their transmission. *Orthohalarachne* spp. mites were identified in the nasopharynx of some necropsied pups, although they were not associated with gross pathological changes (unpubl. data); it is likely that these mites are of minor health significance (Dunlap et al. 1976; Nicholson and Fanning 1981) and the collection of invasive nasal swabs to diagnose infestation in live pups was not undertaken in this study. Finally, infestation with sucking lice (*Antarctophthirus microchir*) is reported from the Australian sea lion at both Seal Bay and Dangerous Reef (McIntosh and Murray 2007); in general, lice infestation can cause anaemia in pinnipeds (Thompson et al. 1998; Dailey 2001), although prior to the publications presented in this thesis, the clinical impact of *A. microchir* had not been reported for this host. In this study, the presence of lice in the pelage of pups was recorded during clinical examinations and this data was incorporated into statistical models to differentiate the estimated effects of lice infestation from hookworm infection. Lice infestation was found to be common in pups (overall prevalence > 70 %; see Chapter 4, Table S4) but, in contrast to hookworm infection, was only associated with relatively mild haematological effects (mild decrease in packed cell volume and mild increase in total plasma protein) and is considered unlikely to be having a significant impact on the health status of Australian sea lion pups. A limitation of this study is that the actual intensity of parasitic infections in live pups was not determined; for hookworm infection, this was due to the absence of validated methods to estimate infection intensity from faecal egg counts (Chapter 3), whereas for lice infestation, direct counting was not undertaken in order to reduce pup handling time. (Note, as reported in Chapter 5, the intensity of lice infestation was crudely estimated based on subjective scoring, however, these estimates were only utilised to compare approximate lice infestation intensity between treatment groups; in order to avoid potentially introducing bias, these estimates were not used in other

analyses). Hence, the haematological effects attributed to these parasites should be interpreted as the mean estimated effect of the mean intensity of infection for each respective parasite. As such, some of the effect of these parasites that are related to the intensity of infection may have been attributed to interrelated host or environment factors, such as body condition or year of sampling, or may have contributed towards the total amount of unexplained variance in the models. Indeed, given that the prevalence and intensity of lice infestation may increase secondary to hookworm infection (Chapters 4 and 5), it is possible that some of the effects attributed to *A. microchir* were actually due to hookworm infection and are correlatively, rather than causatively, associated with their occurrence. Regardless, given the absence of evidence to implicate other pathogens as significant agents of disease in Australian sea lion pups, the findings presented in this thesis assist in the characterisation of the clinical impact of hookworm infection in this species and highlight the key pathological role of *U. sanguinis* in influencing the health status of Australian sea lion pups.

Chapter 5 of this thesis detailed investigations to test the association of *U. sanguinis* with disease in Australian sea lion pups by experimentally manipulating the host-parasite relationship via anthelmintic administration. The results demonstrated that ivermectin is a highly effective and safe treatment to eliminate hookworm infection in this species, similar to that observed for northern fur seal and New Zealand sea lion pups (Beekman 1984; Castinel et al. 2007a; Chilvers et al. 2009; DeLong et al. 2009). In addition, ivermectin administration was identified to be effective at removing lice infestation and it is likely that treatment would have also removed *Orthohalarachne* spp. infestations (Lynch 1999). As such, it was not possible to definitively distinguish between the independent effects of these parasites, however, as previously discussed, given that *U. sanguinis* is implicated to have greater pathological impact than *A. microchir* (Chapter 4)

and that *Orthohalarachne* spp. are usually of minor health significance (Dunlap et al. 1976; Nicholson and Fanning 1981), it is likely that the changes observed in clinical parameters in treated pups were predominantly due to the elimination of hookworm infection. Pups administered ivermectin had significantly higher erythrocyte counts and significantly lower eosinophil counts relative to saline-treated control pups at 1–2 months post-treatment. These findings assist the verification of the causative association of *U. sanguinis* with disease in Australian sea lion pups. Further investigation utilising narrow-spectrum parasite-specific anthelmintics could be undertaken to facilitate improved estimation of the relative effects of each parasite species.

Unexpectedly, ivermectin treatment was not significantly associated with beneficial effects on Australian sea lion pup growth and survival, as observed for northern fur seal and New Zealand sea lion pups (Chilvers et al. 2009; DeLong et al. 2009). Reasons for these non-significant findings are not readily apparent, although several possibilities are proposed. Firstly, a key difference in this study is that the age of recruited pups was unknown, whereas northern fur seal pups were treated at approximately 2 weeks of age and New Zealand sea lion pups were treated at 3, 7, and 30 days of age (Chilvers et al. 2009; DeLong et al. 2009). In this study, it was not possible to recruit and treat known-age pups during the prepatent period of hookworm infection due to colony access and temporal limitations, as well as the practical, ethical, and welfare considerations of capturing, sampling, and treating Australian sea lion pups within the first few days of birth. Instead, this study aimed to recruit pups that, on the basis of morphological characteristics and hookworm infection status, were likely to be less than 1–2 months old (i.e. within the relatively early period of patent hookworm infection) and, hence, still expected to be at increased risk of mortality (McIntosh and Kennedy 2013). However, the apparent mortality rates of recruited pups, irrespective of treatment group, were markedly lower than the

colony pup mortality rates, indicating that the mean age of recruited pups may have been greater than expected. In addition, concurrent investigations identified that juvenile *U. sanguinis* are functionally capable of causing pathology during the prepatent period and that up to ~ 30 % of pup mortality occurs during this period (Chapters 2 and 3). These findings suggest that in order to reduce hookworm-associated pup mortality, it is critical to prevent or significantly reduce the impact of hookworm infection prior to the onset of patency.

Another possible explanation for the apparent lack of difference in survival between treatment groups could be that pups which were not resighted, either due to emigration away from Dangerous Reef or unidentified mortality, were categorised together as ‘unknown survival’; it is possible that ivermectin treatment increased survival and was associated with earlier emigration. Although the occurrence and distribution of time to unknown survival were not significantly different between treatment groups (Chapter 5, Fig. 6), due to the infrequency and short duration of field trips, there is insufficient evidence to discount this hypothesis.

Not only was ivermectin treatment not associated with positive effects on pup growth, but relatively longer pups treated with ivermectin increased in standard length at a slower rate than matched controls. This unexpected finding is similar to the reduced rates of growth identified in children with low whipworm (*Trichuris trichiura*) infection intensity that were treated with albendazole (Forrester et al. 1998; Tee et al. 2013). In these studies, it was hypothesised that low nematode infection intensity was associated with beneficial host effects. As longer pups are relatively older than shorter pups, they are in a later stage of hookworm infection and may have reduced infection intensity. It is possible that for Australian sea lion pups, low hookworm infection intensity or late-stage hookworm infection could have some beneficial host effects; in these longer pups,

treatment to eliminate their hookworm infections may have manifested as reduced growth. Finally, it is possible that ivermectin has adverse physiological effects in the Australian sea lion; this may have been evident only in older pups with reduced hookworm infection intensity as the presumed beneficial growth effects of parasite elimination in younger pups outweighed – or were equivalent to – the negative effects of treatment.

The findings of Chapter 5 contribute towards understanding the utility of anthelmintic treatment as a tool for the conservation management of the Australian sea lion. Although this study demonstrated that ivermectin effectively eliminates hookworm infection and is associated with haematological changes indicative of improved health status, critically, this study did not demonstrate a survival benefit to treated pups, which is essential to recommending this intervention be implemented. Importantly, this study demonstrated the challenges associated with treating pups of this species shortly after birth at a remote colony; given the evident impact of hookworm infection on clinical health parameters and its association with the magnitude of colony pup mortality, it is probable that had pups been recruited and treated during the prepatent period of infection that a survival benefit would have been observed. Before anthelmintic administration can be recommended as a tool for the conservation management of Australian sea lion pups, it is essential to demonstrate short- and long-term improvements in pup survival and breeding success following treatment, as well as to investigate the possible implications of treatment for the health, development, and survival of pups born to treated individuals. In addition, further investigation is required to assess the potential collateral ecological and evolutionary consequences of treatment, including the reduction or loss of other endemic parasites and the impact of introducing anthelmintics into the environment (Lumaret et al. 2012; Stringer and Linklater 2014). The future role of anthelmintic treatment as a component of the conservation management of the Australian sea lion is likely to be as a

sporadic interventional tool to reduce pup mortality; for example, the need to reduce the impact of hookworm infection may arise due to the occurrence of additional health stressors contributing to increased mortality, as observed for New Zealand sea lion pups during high mortality epizootics associated with *K. pneumoniae* infection (Chilvers et al. 2009). The routine use of anthelmintic treatment to support population recovery across the range of the Australian sea lion is not logistically feasible given the distribution of the population across multiple remote colonies and their asynchronous, extended breeding seasons, resulting in considerable heterogeneity in the age of pups within and between colonies, which would necessitate a near-constant presence within colonies during the breeding season to ensure treatment is administered to pups at an appropriate age to be effective. Although anthelmintic treatment may be possible at some readily accessible and highly monitored colonies, this intervention should not be considered a panacea for all of the threats impacting on the population recovery of this species.

An additional practical outcome of this thesis is the demonstration of methodology to preserve whole-blood samples in the field, facilitating the delayed analysis of haematological parameters and thereby enabling immunological and health investigations to be undertaken that otherwise would not have been logistically feasible (Chapters 4 and 5). The implementation of this methodology in future studies could substantially improve the utility and value of obtaining blood samples from free-ranging species at locations otherwise too remote from laboratory facilities; the methodology outlined in this thesis is already being used to benefit studies of other Australian mammals including the long-nosed fur seal (unpubl. data), Tasmanian devil (*Sarcophilus harrisii*; E. Peel, pers. comm.), koala (*Phascolarctos cinereus*; G. Pye, pers. comm.), and eastern grey kangaroo (*Macropus giganteus*; R. Gray, pers. comm.).

6.2 Conclusion

This thesis investigated the taxonomy, epidemiology, clinical impact, and management of hookworm infection in the Australian sea lion to address the hypothesis that hookworm infection is a significant cause of disease and mortality in this species. This thesis determined that a single novel species of *Uncinaria* parasitises the Australian sea lion, a finding critical to understanding and describing the epidemiology of hookworm infection in this host. The findings presented in this thesis indicate that, as for hookworm infection in other otariid species, transmammary transmission in the immediate post-parturient period is likely the predominant route leading to patent hookworm infection in pups; however, in contrast to the fundamental role that colony substrate appears to play in shaping the epidemiology of hookworm infection in these other hosts, this thesis determined that all Australian sea lion pups are infected with *U. sanguinis* irrespective of the type of colony substrate, and that the intensity of hookworm infection appears to be influenced by colony-specific seasonal differences in host behaviour. The dynamics of hookworm infection were related to the occurrence of seasonal patterns in clinical health parameters and the magnitude of colony pup mortality, implicating *U. sanguinis* as a key factor shaping the population demography of this species. Critically, this thesis quantified the clinical impact of hookworm infection on the health status of Australian sea lion pups and demonstrated causative links between *U. sanguinis* and the occurrence of disease.

The baseline epidemiological data and the haematological reference intervals described in this thesis can facilitate the implementation of long-term health surveillance in this species, which is critical for the early recognition of emerging disease and changes in disease impact so that interventional strategies can be implemented. In addition, this thesis demonstrated the effectiveness and safety of ivermectin administration to eliminate

hookworm infection in pups, yet highlighted the logistical and practical challenges associated with treating neonatal pups of this species.

Finally, this thesis determined that *U. sanguinis* is an important cause of disease in the Australian sea lion and implicated this parasite as a major factor contributing towards pup mortality. As such, this body of work contributes towards an improved understanding of the role of infectious disease in influencing the health status and population demography of this endangered species, informing conservation management and providing a solid foundation for further investigations of the effect of disease on the health status of this and other free-ranging species.

References

References

- Acevedo-Whitehouse K, Petetti L, Duignan P, Castinel A (2009) Hookworm infection, anaemia and genetic variability of the New Zealand sea lion. *Proc R Soc B* 276:3523–3529. doi:10.1098/rspb.2009.1001
- Alatzas DG, Mylonakis ME, Kazakos GM, Kostoulas P, Kritsepi-Konstantinou M, Polizopoulou ZS (2014) Reference values and repeatability of buccal mucosal bleeding time in healthy sedated cats. *J Feline Med Surg* 16:144–148. doi:10.1177/1098612x13502973
- Albon SD, Stien A, Irvine RJ, Langvatn R, Ropstad E, Halvorsen O (2002) The role of parasites in the dynamics of a reindeer population. *Proc R Soc Lond B* 269:1625–1632. doi:10.1098/rspb.2002.2064
- Allison RW, Meinkoth JH (2007) Hematology without the numbers: in-clinic blood film evaluation. *Vet Clin N Am Small Anim Pract* 37:245–266. doi:10.1016/j.cvsm.2006.10.002
- Anderson RM, Schad GA (1985) Hookworm burdens and faecal egg counts: an analysis of the biological basis of variation. *Trans R Soc Trop Med Hyg* 79:812–825. doi:10.1016/0035-9203(85)90128-2
- Anon (1983) Island conservation parks of Backstairs Passage and Encounter Bay management plans: The Pages, West Island, Seal Island and Pullen Island. Department of Environment and Planning, Adelaide
- Australian Government, Department of Sustainability, Environment, Water, Population and Communities (2013a) Recovery plan for the Australian sea lion (*Neophoca cinerea*). Commonwealth of Australia, Canberra

- Australian Government, Department of Sustainability, Environment, Water, Population and Communities (2013b) Issues paper for the Australian sea lion (*Neophoca cinerea*). Commonwealth of Australia, Canberra
- Banish LD, Gilmartin WG (1988) Hematology and serum chemistry of the young Hawaiian monk seal (*Monachus schauinslandi*). *J Wildl Dis* 24:225–230. doi:10.7589/0090-3558-24.2.225
- Barnes J, Higgins DP, Gray R (2008) Pinnipeds. In: Vogelnest L, Woods R (eds) *Medicine of Australian mammals*. CSIRO Publishing, Collingwood, pp 541–589
- Baylis AMM, Hamer DJ, Nichols PD (2009) Assessing the use of milk fatty acids to infer the diet of the Australian sea lion (*Neophoca cinerea*). *Wildl Res* 36:169–176. doi:10.1071/WR08046
- Baylis HA (1933) A new species of the nematode genus *Uncinaria* from a sea-lion, with some observations on related species. *Parasitology* 25:308–316. doi:10.1017/S0031182000019508
- Baylis HA (1947) A redescription of *Uncinaria lucasi* Stiles, a hookworm of seals. *Parasitology* 38:160–162. doi:10.1017/S0031182000023118
- Beckmen KB, Blake JE, Ylitalo GM, Stott JL, O’Hara TM (2003) Organochlorine contaminant exposure and associations with hematological and humoral immune functional assays with dam age as a factor in free-ranging northern fur seal pups (*Callorhinus ursinus*). *Mar Pollut Bull* 46:594–606. doi:10.1016/S0025-326X(03)00039-0
- Beekman GK (1984) Clinical use of ivermectin against the hookworm (*Uncinaria lucasi*) of northern fur seal pups (*Callorhinus ursinus*). In: *Internat Assoc Aqua An Med (IAAAM) Proceed.*

- Beldomenico PM, Telfer S, Gebert S, Lukomski L, Bennett M, Begon M (2008) The dynamics of health in wild field vole populations: a haematological perspective. *J Anim Ecol* 77:984–997. doi:10.1111/j.1365-2656.2008.01413.x
- Berón-Vera B, Crespo EA, Raga JA, Pedraza SN (2004) *Uncinaria hamiltoni* (Nematoda: Ancylostomatidae) in South American sea lions, *Otaria flavescens*, from Northern Patagonia, Argentina. *J Parasitol* 90:860–863. doi:10.1645/GE-182R
- Berta A, Churchill M (2012) Pinniped taxonomy: review of currently recognized species and subspecies, and evidence used for their description. *Mammal Rev* 42:207–234. doi:10.1111/j.1365-2907.2011.00193.x
- Beveridge I (1980) *Uncinaria hydromyidis* sp. n. (Nematoda: Ancylostomatidae) from the Australian water rat, *Hydromys chrysogaster*. *J Parasitol* 66:1027–1031. doi:10.2307/3280410
- Beveridge I (2002) Australian hookworms (Ancylostomatoidea): a review of the species present, their distributions and biogeographical origins. *Parasitologia* 44:83–88
- Bigg MA, Lyons ET (1981) Clinical observations on three northern fur seal pups treated with dichlorvos. *J Am Vet Med Assoc* 179:1284–1286
- Boily F, Beaudoin S, Measures LN (2006) Hematology and serum chemistry of harp (*Phoca groenlandica*) and hooded seals (*Cystophora cristata*) during the breeding season, in the Gulf of St. Lawrence, Canada. *J Wildl Dis* 42:115–132. doi:10.7589/0090-3558-42.1.115
- Bordes F, Morand S (2011) The impact of multiple infections on wild animal hosts: a review. *Infect Ecol Epidemiol* 1:7346. doi:10.3402/iee.v1i0.7346
- Bossart GD (2011) Marine mammals as sentinel species for oceans and human health. *Vet Pathol* 48:676–690. doi:10.1177/0300985810388525

- Botto C, Mañé-Garzón F (1975) Sobre una nueva especie del género *Uncinaria* (Nematoda, Strongyloidea) de *Otaria flavescens* Shaw y la especiación en el género *Uncinaria* en pinnípedos americanos. *Rev Biol Urug* 3:127–141
- Boyd IL (1991) Environmental and physiological factors controlling the reproductive cycles of pinnipeds. *Can J Zool* 69:1135–1148. doi:10.1139/z91-162
- Brock PM, Hall AJ, Goodman SJ, Cruz M, Acevedo-Whitehouse K (2013) Applying the tools of ecological immunology to conservation: a test case in the Galapagos sea lion. *Anim Conserv* 16:19–31. doi:10.1111/j.1469-1795.2012.00567.x
- Bryden MM, Lim GHK (1969) Blood parameters of the southern elephant seal (*Mirounga leonina*, Linn.) in relation to diving. *Comp Biochem Physiol* 28:139–148. doi:10.1016/0010-406X(69)91328-0
- Burke TM, Roberson EL (1985) Prenatal and lactational transmission of *Toxocara canis* and *Ancylostoma caninum*: experimental infection of the bitch at midpregnancy and at parturition. *Int J Parasitol* 15:485–490. doi:10.1016/0020-7519(85)90041-4
- Campbell RA, Gales NJ, Lento GM, Baker CS (2008a) Islands in the sea: extreme female natal site fidelity in the Australian sea lion, *Neophoca cinerea*. *Biol Lett* 4:139–142. doi:10.1098/rsbl.2007.0487
- Campbell RA, Holley D, Christianopoulos D, Caputi N, Gales NJ (2008b) Mitigation of incidental mortality of Australian sea lions in the west coast rock lobster fishery. *Endanger Species Res* 5:345–358. doi:10.3354/esr00155
- Castellini JM, Castellini MA, Kretzmann MB (1990) Circulatory water concentration in suckling and fasting northern elephant seal pups. *J Comp Physiol B* 160:537–542. doi:10.1007/BF00258981

- Castellini JM, Meiselman HJ, Castellini MA (1996) Understanding and interpreting hematocrit measurements in pinnipeds. *Mar Mamm Sci* 12:251–264. doi:10.1111/j.1748-7692.1996.tb00574.x
- Castellini MA, Davis RW, Loughlin TR, Williams TM (1993) Blood chemistries and body condition of Steller sea lion pups at Marmot Island, Alaska. *Mar Mamm Sci* 9:202–208. doi:10.1111/j.1748-7692.1993.tb00446.x
- Castinel A, Duignan PJ, Pomroy WE, Lyons ET, Nadler SA, Dailey MD, Wilkinson IS, Chilvers BL (2006) First report and characterization of adult *Uncinaria* spp. in New Zealand Sea Lion (*Phocarctos hookeri*) pups from the Auckland Islands, New Zealand. *Parasitol Res* 98:304–309. doi:10.1007/s00436-005-0069-8
- Castinel A (2007) Causes of neonatal mortality in the New Zealand sea lion (*Phocarctos Hookeri*). PhD Dissertation, Massey University
- Castinel A, Duignan PJ, Lyons ET, Pomroy WE, Gibbs NJ, Lopez-Villalobos N, Chilvers BL, Wilkinson IS (2007a) Epidemiology of hookworm (*Uncinaria* spp.) infection in New Zealand (Hooker's) sea lion (*Phocarctos hookeri*) pups on Enderby Island, Auckland Islands (New Zealand) during the breeding seasons from 1999/2000 to 2004/2005. *Parasitol Res* 101:53–62. doi:10.1007/s00436-006-0453-z
- Castinel A, Duignan PJ, Pomroy WE, Lopez-Villalobos N, Gibbs NJ, Chilvers BL, Wilkinson IS (2007b) Neonatal mortality in New Zealand sea lions (*Phocarctos hookeri*) at Sandy Bay, Enderby Island, Auckland Islands from 1998 to 2005. *J Wildl Dis* 43:461–474. doi:10.7589/0090-3558-43.3.461
- Castinel A, Grinberg A, Pattison R, Duignan PJ, Pomroy B, Rogers L, Wilkinson IS (2007c) Characterization of *Klebsiella pneumoniae* isolates from New Zealand sea lion (*Phocarctos hookeri*) pups during and after the epidemics on Enderby Island, Auckland Islands. *Vet Microbiol* 122:178–184. doi:10.1016/j.vetmic.2006.12.024

- Cerioti F, Hinzmann R, Panteghini M (2009) Reference intervals: the way forward. *Ann Clin Biochem* 46:8–17. doi:10.1258/acb.2008.008170
- Chabaud AG, Brygoo ER, Tchérakoff R (1964) Nématodes parasites d'insectivores malgaches. *Bull Mus Natl Hist Nat* 36:245–261
- Chabaud AG, Bain O, Houin R (1966) Nématodes de Potamochères malgaches. *Ann Parasitol* 41:599–606
- Chabaud AG, Durette-Desset MC (1975) *Uncinaria (Megadeirides) olsenii* n. sp., Nématode à caractères archaïques parasite d'un *Tupaia* à Bornéo. *Ann Parasitol Hum Comp* 50:789–793
- Chernick MR (2011) *Bootstrap methods: a guide for practitioners and researchers*. 2nd edn. John Wiley & Sons, Hoboken
- Chilvers BL, Duignan PJ, Robertson BC, Castinel A, Wilkinson IS (2009) Effects of hookworms (*Uncinaria* sp.) on the early growth and survival of New Zealand sea lion (*Phocarctos hookeri*) pups. *Polar Biol* 32:295–302. doi:10.1007/s00300-008-0559-0
- Christensen NØ, Nansen P, Fagbemi BO, Monrad J (1987) Heterologous antagonistic and synergistic interactions between helminths and between helminths and protozoans in concurrent experimental infection of mammalian hosts. *Parasitol Res* 73:387–410. doi:10.1007/BF00538196
- Churchill M, Boessenecker RW, Clementz MT (2014) Colonization of the Southern Hemisphere by fur seals and sea lions (Carnivora: Otariidae) revealed by combined evidence phylogenetic and Bayesian biogeographical analysis. *Zool J Linn Soc* 172:200–225. doi:10.1111/zoj.12163

- Clark CA, Burns JM, Schreer JF, Hammill MO (2007) A longitudinal and cross-sectional analysis of total body oxygen store development in nursing harbor seals (*Phoca vitulina*). *J Comp Physiol B* 177:217–227. doi:10.1007/s00360-006-0123-6
- Clark P, Boardman WS, Duignan PJ (2002) Cytology of haematological cells of otariid seals indigenous to Australasian waters. *Aust Vet J* 80:161–164. doi:10.1111/j.1751-0813.2002.tb11383.x
- Clark P (2004) *Haematology of Australian mammals*. CSIRO Publishing, Collingwood
- Costa DP, Gales NJ (2003) Energetics of a benthic diver: seasonal foraging ecology of the Australian sea lion, *Neophoca cinerea*. *Ecol Monogr* 73:27–43
- Cousins DV, Williams SN, Reuter R, Forshaw D, Chadwick B, Coughran D, Collins P, Gales NJ (1993) Tuberculosis in wild seals and characterisation of the seal bacillus. *Aust Vet J* 70:92–97. doi:10.1111/j.1751-0813.1993.tb03284.x
- Coyne MJ, Smith G (1992) The mortality and fecundity of *Haemonchus contortus* in parasite-naïve and parasite-exposed sheep following single experimental infections. *Int J Parasitol* 22:315–325. doi:10.1016/S0020-7519(05)80009-8
- Cumming G (2009) Inference by eye: reading the overlap of independent confidence intervals. *Statist Med* 28:205–220. doi:10.1002/sim.3471
- Dailey MD, Brownell RL (1972) A checklist of marine mammal parasites. In: Ridgway SH (ed) *Mammals of the sea: biology and medicine*. Charles C Thomas, Illinois, pp 528–576
- Dailey MD (2001) Parasitic Diseases. In: Dierauf LA, Gulland FMD (eds) *CRC handbook of marine mammal medicine*. 2nd edn. CRC Press, Florida, pp 357–382
- Davey D, Manickam N, Simms BT, Harrison LM, Vermeire JJ, Cappello M (2013) Frequency and intensity of exposure mediate resistance to experimental infection

- with the hookworm, *Ancylostoma ceylanicum*. *Exp Parasitol* 133:243–249.
doi:10.1016/j.exppara.2012.11.010
- Dawson CE (2005) Anti-Brucella antibodies in pinnipeds of Australia. *Microbiology Australia* 26:87–89
- Deem SL, Karesh WB, Weisman W (2001) Putting theory into practice: wildlife health in conservation. *Conserv Biol* 15:1224–1233. doi:10.1111/j.1523-1739.2001.00336.x
- DeLong RL, Orr AJ, Jenkinson RS, Lyons ET (2009) Treatment of northern fur seal (*Callorhinus ursinus*) pups with ivermectin reduces hookworm-induced mortality. *Mar Mamm Sci* 25:944–948. doi:10.1111/j.1748-7692.2008.00274.x
- Delport TC, Asher AJ, Beaumont LJ, Webster KN, Harcourt RG, Power ML (2014) *Giardia duodenalis* and *Cryptosporidium* occurrence in Australian sea lions (*Neophoca cinerea*) exposed to varied levels of human interaction. *Int J Parasitol Parasites Wildl* 3:269–275. doi:10.1016/j.ijppaw.2014.09.001
- Domrow R (1974) Notes on halarachnine larval morphology and a new species of *Pneumonyssus* Banks (Acari: Dermanyssidae). *Aust J Entomol* 13:17–26.
doi:10.1111/j.1440-6055.1974.tb02286.x
- Dubois G, Angel LM (1976) *Mesostephanus neophocae* n. sp. (Strigeata: Prohemistomidae), parasite d'une otarie d'Australie, *Neophoca cinerea* (Péron et Lesueur). *Bull Soc Neuchâtel Sci Nat* 99:29–32. doi:10.5169/seals-89086
- Dunlap JS, Piper RC, Keyes MC (1976) Lesions associated with *Orthohalarachne attenuata* (Halarachnidae) in the northern fur seal (*Callorhinus ursinus*). *J Wildl Dis* 12:42–44. doi:10.7589/0090-3558-12.1.42
- Efron B (1982) The jackknife, the bootstrap and other resampling plans. vol 38. SIAM, Philadelphia
- Fay FR (1989) Toxoplasmosis in seals. *Aust Adv Vet Sci*:109–110

- Forrester JE, Bailar III JC, Esrey SA, José MV, Castillejos BT, Ocampo G (1998) Randomised trial of albendazole and pyrantel in symptomless trichuriasis in children. *Lancet* 352:1103–1108. doi:10.1016/s0140-6736(97)08325-6
- Forshaw D, Phelps GR (1991) Tuberculosis in a captive colony of pinnipeds. *J Wildl Dis* 27:288–295. doi:10.7589/0090-3558-27.2.288
- Fowler SL, Costa DP, Arnould JPY (2007a) Ontogeny of movements and foraging ranges in the Australian sea lion. *Mar Mamm Sci* 23:598–614. doi:10.1111/j.1748-7692.2007.00134.x
- Fowler SL, Costa DP, Arnould JPY, Gales NJ, Burns JM (2007b) Ontogeny of oxygen stores and physiological diving capability in Australian sea lions. *Funct Ecol* 21:922–935. doi:10.1111/j.1365-2435.2007.01295.x
- Fujiwara RT, Geiger SM, Bethony J, Mendez S (2006) Comparative immunology of human and animal models of hookworm infection. *Parasite Immunol* 28:285–293. doi:10.1111/j.1365-3024.2006.00821.x
- Gales NJ, Cheal AJ, Pobar GJ, Williamson P (1992) Breeding biology and movements of Australian sea-lions, *Neophoca cinerea*, off the west coast of Western Australia. *Wildl Res* 19:405–416. doi:10.1071/WR9920405
- Gales NJ, Shaughnessy PD, Dennis TE (1994) Distribution, abundance and breeding cycle of the Australian sea lion *Neophoca cinerea* (Mammalia: Pinnipedia). *J Zool* 234:353–370. doi:10.1111/j.1469-7998.1994.tb04853.x
- Gasser RB, Newton SE (2000) Genomic and genetic research on bursate nematodes: significance, implications and prospects. *Int J Parasitol* 30:509–534. doi:10.1016/S0020-7519(00)00021-7
- George-Nascimento M, Lima M, Ortiz E (1992) A case of parasite-mediated competition? Phenotypic differentiation among hookworms *Uncinaria* sp. (Nematoda:

- Ancylostomatidae) in sympatric and allopatric populations of South American sea lions *Otaria byronia*, and fur seals *Arctocephalus australis* (Carnivora: Otariidae). *Mar Biol* 112:527–533. doi:10.1007/BF00346169
- Geraci JR (1971) Functional Hematology of the Harp Seal *Pagophilus groenlandicus*. *Physiol Zool* 44:162–170. doi:10.2307/30155568
- Geraci JR, Fortin JF, St. Aubin DJ, Hicks BD (1981) The seal louse, *Echinophthirius horridus*: an intermediate host of the seal heartworm, *Dipetalonema spirocauda* (Nematoda). *Can J Zool* 59:1457–1459. doi:10.1139/z81-197
- Gibbens J, Arnould JPY (2009) Interannual variation in pup production and the timing of breeding in benthic foraging Australian fur seals. *Mar Mamm Sci* 25:573–587. doi:10.1111/j.1748-7692.2008.00270.x
- Goldsworthy SD, Lowther AD, Shaughnessy PD, McIntosh RR, Page B (2007) Assessment of pup production and the maternal investment strategies of the Australian sea lion *Neophoca cinerea* at Dangerous Reef in the 2006-07 breeding season. SARDI Publication Number F2007/000929-1. SARDI Research Report Series No. 249, Adelaide
- Goldsworthy SD, Page B (2007) A risk-assessment approach to evaluating the significance of seal bycatch in two Australian fisheries. *Biol Conserv* 139:269–285. doi:10.1016/j.biocon.2007.07.010
- Goldsworthy SD, Gales NJ (2008) *Neophoca cinerea*. In: IUCN Red List of Threatened Species. Version 2013.2. <http://www.iucnredlist.org/details/14549>. Accessed 1 May 2014
- Goldsworthy SD, McKenzie J, Shaughnessy PD, McIntosh RR, Page B, Campbell RA (2009a) An update of the report: understanding the impediments to the growth of

- Australian sea lion populations. SARDI Publication Number F2008/00847-1. SARDI Research Report Series No. 356, Adelaide
- Goldsworthy SD, Page B, Lowther AD, Rogers P, Peters KJ, Shaughnessy PD (2009b) Pup production assessment of the Australian sea lion *Neophoca cinerea* at Dangerous Reef and English Island, South Australia. SARDI Publication Number F2009/000088-1. SARDI Research Report Series No. 338, Adelaide
- Goldsworthy SD, Page B, Shaughnessy PD (2010a) Maintaining the monitoring of pup production at key Australian sea lion colonies in South Australia (2009/10). SARDI Publication Number F2010/000665-1. SARDI Research Report Series No. 491, Adelaide
- Goldsworthy SD, Page B, Shaughnessy PD, Linnane A (2010b) Mitigating Seal Interactions in the SRLF and the Gillnet Sector SESSF in South Australia. SARDI Publication Number F2009/000613-1. SARDI Research Report Series No. 405, Adelaide
- Goldsworthy SD, Page B, Lowther AD, Shaughnessy PD (2012) Maintaining the monitoring of pup production at key Australian sea lion colonies in South Australia (2010/11). SARDI Publication Number F2010/000665-2. SARDI Research Report Series No. 601, Adelaide
- Goldsworthy SD, Lowther AD, Shaughnessy PD (2013) Maintaining the monitoring of pup production at key Australian sea lion colonies in South Australia (2011/12). SARDI Publication Number F2010/000665-3. SARDI Research Report series No. 739, Adelaide
- Goldsworthy SD, Kennedy CW, Shaughnessy PD, Mackay AI (2014a) Monitoring of Seal Bay and other pinniped populations on Kangaroo Island: 2012-2015. SARDI

- Publication Number F2014/000332-1. SARDI Research Report Series No. 782, Adelaide
- Goldsworthy SD, Mackay AI, Shaughnessy PD, Bailleul F, McMahon CR (2014b) Maintaining the monitoring of pup production at key Australian sea lion colonies in South Australia (2013/14). SARDI Publication Number F2010/000665-4. SARDI Research Report Series No. 818, Adelaide
- Gómez A, Nichols E (2013) Neglected wild life: parasitic biodiversity as a conservation target. *Int J Parasitol Parasites Wildl* 2:222–227. doi:10.1016/j.ijppaw.2013.07.002
- Gray R, Canfield P, Rogers T (2005) Serum proteins in the leopard seal, *Hydrurga leptonyx*, in Prydz Bay, Eastern Antarctica and the coast of NSW, Australia. *Comp Biochem Physiol B* 142:67–78. doi:10.1016/j.cbpc.2005.05.016
- Greig DJ, Gulland FMD, Kreuder C (2005) A decade of live California sea lion (*Zalophus californianus*) strandings along the central California coast: causes and trends, 1991-2000. *Aquat Mamm* 31:11–22. doi:10.1578/AM.31.1.2005.11
- Greig DJ, Gulland FMD, Rios CA, Hall AJ (2010) Hematology and serum chemistry in stranded and wild-caught harbor seals in central California: reference intervals, predictors of survival, and parameters affecting blood variables. *J Wildl Dis* 46:1172–1184. doi:10.7589/0090-3558-46.4.1172
- Hall AJ (1998) Blood chemistry and hematology of gray seal (*Halichoerus grypus*) pups from birth to postweaning. *J Zoo Wildl Med* 29:401–407
- Hall AJ, Wells RS, Sweeney JC, Townsend FI, Balmer BC, Hohn AA, Rhinehart HL (2007) Annual, seasonal and individual variation in hematology and clinical blood chemistry profiles in bottlenose dolphins (*Tursiops truncatus*) from Sarasota Bay, Florida. *Comp Biochem Physiol A* 148:266–277. doi:10.1016/j.cbpa.2007.04.017

- Hamer DJ, Goldsworthy SD, Costa DP, Fowler SL, Page B, Sumner MD (2013a) The endangered Australian sea lion extensively overlaps with and regularly becomes by-catch in demersal shark gill-nets in South Australian shelf waters. *Biol Conserv* 157:386–400. doi:10.1016/j.biocon.2012.07.010
- Hamer GL, Anderson TK, Berry GE, Makohon-Moore AP, Crafton JC, Brawn JD, Dolinski AC, Krebs BL, Ruiz MO, Muzzall PM, Goldberg TL, Walker ED (2013b) Prevalence of filarioid nematodes and trypanosomes in American robins and house sparrows, Chicago USA. *Int J Parasitol Parasites Wildl* 2:42–49. doi:10.1016/j.ijppaw.2012.11.005
- Hasegawa H (1989) Two new nematodes from the Iriomote cat, *Prionailurus iriomotensis*, from Okinawa: *Uncinaria (Uncinaria) maya* n. sp. (Ancylostomatoidea) and *Molineus springsmithi yayeyamanus* n. subsp. (Trichostrongyloidea). *J Parasitol* 75:863–869. doi:10.2307/3282864
- Haynes BT, Marcus AD, Šlapeta J, Gray R (2013) Hookworms (*Uncinaria* sp.) do not segregate according to the restriction of the host, the Australian sea lion (*Neophoca cinerea*). Honours Dissertation, The University of Sydney
- Haynes BT, Marcus AD, Higgins DP, Gongora J, Gray R, Šlapeta J (2014) Unexpected absence of genetic separation of a highly diverse population of hookworms from geographically isolated hosts. *Infect Genet Evol* 28:192–200. doi:10.1016/j.meegid.2014.09.022
- Hernández-Orts JS, Montero FE, Juan-García A, García NA, Crespo EA, Raga JA, Aznar FJ (2012) Intestinal helminth fauna of the South American sea lion *Otaria flavescens* and fur seal *Arctocephalus australis* from northern Patagonia, Argentina. *J Helminthol* 87:336–347. doi:10.1017/S0022149X12000454

- Hernández-Orts JS, Scholz T, Brabec J, Kuzmina TA, Kuchta R (2015) High morphological plasticity and global geographical distribution of the Pacific broad tapeworm *Adenocephalus pacificus* (syn. *Diphyllobothrium pacificum*): molecular and morphological survey. *Acta Trop*. doi:10.1016/j.actatropica.2015.05.017
- Higgins LV, Tedman RA (1990) Effect of attacks by male Australian sea lions, *Neophoca cinerea*, on mortality of pups. *J Mammal* 71:617–619. doi:10.2307/1381802
- Higgins LV (1993) The nonannual, nonseasonal breeding cycle of the Australian sea lion, *Neophoca cinerea*. *J Mammal* 74:270–274. doi:10.2307/1382381
- Higgins LV, Gass L (1993) Birth to weaning: parturition, duration of lactation, and attendance cycles of Australian sea lions (*Neophoca cinerea*). *Can J Zool* 71:2047–2055. doi:10.1139/z93-290
- Higgins R (2000) Bacteria and fungi of marine mammals: a review. *Can Vet J* 41:105–116
- Hodges J, Christopher MM (2011) Diagnostic accuracy of using erythrocyte indices and polychromasia to identify regenerative anemia in dogs. *J Am Vet Med Assoc* 238:1452–1458. doi:10.2460/javma.238.11.1452
- Horn PS, Feng L, Li Y, Pesce AJ (2001) Effect of outliers and nonhealthy individuals on reference interval estimation. *Clin Chem* 47:2137–2145
- Horning M, Trillmich F (1997) Development of hemoglobin, hematocrit, and erythrocyte values in Galapagos fur seals. *Mar Mamm Sci* 13:100–113. doi:10.1111/j.1748-7692.1997.tb00614.x
- Hotez PJ, Brooker S, Bethony JM, Bottazzi ME, Loukas A, Xiao S (2004) Hookworm infection. *N Engl J Med* 351:799–807. doi:10.1056/NEJMra032492
- Hudson PJ, Dobson AP, Newborn D (1998) Prevention of population cycles by parasite removal. *Science* 282:2256–2258. doi:10.1126/science.282.5397.2256

- Huffman MA, Gotoh S, Turner LA, Hamai M, Yoshida K (1997) Seasonal trends in intestinal nematode infection and medicinal plant use among chimpanzees in the Mahale Mountains, Tanzania. *Primates* 38:111–125. doi:10.1007/BF02382002
- Hufschmid J, Beveridge I, Handasyde KA (2014) Haematology and serum biochemistry of adult free-ranging mountain brushtail possums (*Trichosurus cunninghami*), including correlations with season, sex, age, habitat type and disease status. *Aust J Zool* 61:430–445. doi:10.1071/ZO12097
- Irvine RJ (2006) Parasites and the dynamics of wild mammal populations. *Anim Sci* 82:775–781. doi:10.1017/ASC2006106
- Jain NC (1993) *Essentials of veterinary hematology*. Lea & Febiger, Philadelphia
- Jellison WL, Milner KC (1958) Salmonellosis (bacillary dysentery) of fur seals. *J Wildl Manage* 22:199–200. doi:10.2307/3797329
- Johnston TH (1937) Entozoa from the Australian hair seal. *Proc Linn Soc NSW* 62:9–16
- Johnston TH, Mawson PM (1941) Nematodes from Australian marine mammals. *Rec South Aust Mus* 6:429–434
- Johnston TH, Mawson PM (1945) Parasitic nematodes. In: Johnston TH (ed) *B.A.N.Z. Antarctic Research Expedition 1929-1931. Reports–Series B (Zoology and Botany)*, vol 5, pt. 2. B.A.N.Z.A.R. Expedition Committee, Adelaide, pp 73–160
- Jordan DS, Stejneger L, Lucas FA, Clark GA (1898) *Second preliminary report of the Bering Sea fur seal investigations*. Government Printing Office, Washington
- Kabay MJ (1996) Toxoplasmosis in a sea lion. *Vet Pathol Rep* 43:29–30
- Katz H, Morgades D, Castro-Ramos M (2012) Pathological and parasitological findings in South American fur seal pups (*Arctocephalus australis*) in Uruguay. *ISRN Zool*. doi:10.5402/2012/586079

- Kennedy-Stoskopf S (2001) Viral diseases. In: Dierauf LA, Gulland FMD (eds) CRC handbook of marine mammal medicine. 2nd edn. CRC Press, Florida, pp 285–307
- Kennedy S, Kuiken T, Jepson PD, Deaville R, Forsyth MA, Barrett T, van de Bildt MWG, Osterhaus ADME, Eybatov T, Duck C, Kydyrmanov A, Mitrofanov I, Wilson S (2000) Mass die-off of Caspian seals caused by canine distemper virus. *Emerg Infect Dis* 6:637–639. doi:10.3201/eid0606.000613
- Keogh MJ, Maniscalco JM, Atkinson S (2010) Steller sea lion (*Eumetopias jubatus*) pups undergo a decrease in circulating white blood cells and the ability of T cells to proliferate during early postnatal development. *Vet Immunol Immunopathol* 137:298–304. doi:10.1016/j.vetimm.2010.05.008
- Keyes MC (1965) Pathology of the northern fur seal. *J Am Vet Med Assoc* 147:1090–1095
- Kirkwood R, Pemberton D, Gales R, Hoskins AJ, Mitchell T, Shaughnessy PD, Arnould JPY (2010) Continued population recovery by Australian fur seals. *Mar Freshw Res* 61:695–701. doi:10.1071/MF09213
- Kirkwood R, Goldsworthy SD (2013) *Fur seals and sea lions*. CSIRO Publishing, Collingwood
- Kolevatova AI, Bukina LA, Vasenin YuA (1998) Diseases and parasites of the northern fur seal. In: Sokolov VE (ed) *The northern fur seal. Taxonomy, morphology, ecology, behavior. Part 2*. Moscow, pp 862–892. (Cited after Lyons et al. 2011b)
- Krämer F, Epe C, Mencke N (2009) Investigations into the prevention of neonatal *Ancylostoma caninum* infections in puppies by application of imidacloprid 10% plus moxidectin 2.5% topical solution to the pregnant dog. *Zoonoses Public Health* 56:34–40. doi:10.1111/j.1863-2378.2008.01181.x

- Kretzmann MB, Costa DP, Higgins LV, Needham DJ (1991) Milk composition of Australian sea lions, *Neophoca cinerea*: variability in lipid content. *Can J Zool* 69:2556–2561. doi:10.1139/z91-360
- Krupp IM (1961) Effects of crowding and of superinfection on habitat selection and egg production in *Ancylostoma caninum*. *J Parasitol* 47:957–961. doi:10.2307/3275030
- Kuiken T, Kennedy S, Barrett T, van de Bildt MWG, Borgsteede FH, Brew SD, Codd GA, Duck C, Deaville R, Eybatov T, Forsyth MA, Foster G, Jepson PD, Kydyrmanov A, Mitrofanov I, Ward CJ, Wilson S, Osterhaus ADME (2006) The 2000 canine distemper epidemic in Caspian seals (*Phoca caspica*): pathology and analysis of contributory factors. *Vet Pathol* 43:321–338. doi:10.1354/vp.43-3-321
- Kuzmina TA, Kuzmin Y (2015) Description of *Uncinaria lyonsi* n. sp. (Nematoda: Ancylostomatidae) from the California sea lion *Zalophus californianus* Lesson (Carnivora: Otariidae). *Syst Parasitol* 90:165–176. doi:10.1007/s11230-014-9539-7
- Ladds P (2009) Pathology of Australian Native Wildlife. CSIRO Publishing, Collingwood
- Lahti A, Hyltoft Petersen P, Boyd JC, Rustad P, Laake P, Solberg HE (2004) Partitioning of nongaussian-distributed biochemical reference data into subgroups. *Clin Chem* 50:891–900. doi:10.1373/clinchem.2003.027953
- Lander ME, Harvey JT, Gulland FMD (2003) Hematology and serum chemistry comparisons between free-ranging and rehabilitated harbor seal (*Phoca vitulina richardsi*) pups. *J Wildl Dis* 39:600–609. doi:10.7589/0090-3558-39.3.600
- Lander ME, Fadely BS, Gelatt TS, Rea LD, Loughlin TR (2014) Serum chemistry reference ranges for Steller sea lion (*Eumetopias jubatus*) pups from Alaska: stock differentiation and comparisons within a North Pacific sentinel species. *EcoHealth* 10:376–393. doi:10.1007/s10393-013-0891-x

- Lane RAB, Morris RJH, Sheedy JW (1972) A haematological study of the southern elephant seal, *Mirounga leonina* (Linn.). *Comp Biochem Physiol* 42:841–850. doi:10.1016/0300-9629(72)90389-1
- Larum Z (2010) Histological and immunohistochemical investigations of selected tissues of the Australian sea lion, *Neophoca cinerea*, with a focus on hookworm disease. Honours Dissertation, The University of Sydney
- Leonardi MS, Crespo EA, Raga JA, Aznar FJ (2013) Lousy mums: patterns of vertical transmission of an amphibious louse. *Parasitol Res* 112:3315–3323. doi:10.1007/s00436-013-3511-3
- Leonardi MS, Palma RL (2013) Review of the systematics, biology and ecology of lice from pinnipeds and river otters (Insecta: Phthiraptera: Anoplura: Echinophthiriidae). *Zootaxa* 3630:445–466. doi:10.11646/zootaxa.3630.3.3
- Leung TLF, Poulin R (2008) Parasitism, commensalism, and mutualism: exploring the many shades of symbioses. *Vie et Milieu / Life and Environment* 58:107–115
- Lichtenfels JR (2009) Strongylida. In: Anderson RC, Chabaud AG, Willmott S (eds) *Keys to the nematode parasites of vertebrates: archival volume*. CABI, Oxfordshire, pp 44–68
- Ling JK (1992) *Neophoca cinerea*. *Mamm Species* 392:1–7. doi:10.2307/3504081
- Ling JK (1999) Exploitation of fur seals and sea lions from Australian, New Zealand and adjacent subantarctic islands during the eighteenth, nineteenth and twentieth centuries. *Aust Zool* 31:323–350. doi:10.7882/AZ.1999.036
- Linn ML, Gardner J, Warrilow D, Darnell GA, McMahon CR, Field I, Hyatt AD, Slade RW, Suhrbier A (2001) Arbovirus of marine mammals: a new alphavirus isolated from the elephant seal louse, *Lepidophthirus macrorhini*. *J Virol* 75:4103–4109. doi:10.1128/JVI.75.9.4103-4109.2001

- López-Olvera JR, Höfle U, Vicente J, Fernández-de-Mera IG, Gortázar C (2006) Effects of parasitic helminths and ivermectin treatment on clinical parameters in the European wild boar (*Sus scrofa*). *Parasitol Res* 98:582–587. doi:10.1007/s00436-005-0099-2
- Loukas A, Prociv P (2001) Immune responses in hookworm infections. *Clin Microbiol Rev* 14:689–703. doi:10.1128/CMR.14.4.689–703.2001
- Lowther AD, Goldsworthy SD (2010) Detecting alternate foraging ecotypes in Australian sea lion (*Neophoca cinerea*) colonies using stable isotope analysis. *Mar Mamm Sci* 27:567–586. doi:10.1111/j.1748-7692.2010.00425.x
- Lowther AD, Goldsworthy SD (2011) Maternal strategies of the Australian sea lion (*Neophoca cinerea*) at Dangerous Reef, South Australia. *Aust J Zool* 59:54–62. doi:10.1071/ZO11025
- Lowther AD, Harcourt RG, Hamer DJ, Goldsworthy SD (2011) Creatures of habit: foraging habitat fidelity of adult female Australian sea lions. *Mar Ecol Prog Ser* 443:249–263. doi:10.3354/meps09392
- Lowther AD, Harcourt RG, Goldsworthy SD, Stow A (2012) Population structure of adult female Australian sea lions is driven by fine-scale foraging site fidelity. *Anim Behav* 83:691–701. doi:10.1016/j.anbehav.2011.12.015
- Lowther AD, Harcourt RG, Page B, Goldsworthy SD (2013) Steady as he goes: at-sea movement of adult male Australian sea lions in a dynamic marine environment. *PLoS ONE* 8:e74348. doi:10.1371/journal.pone.0074348
- Lucas Z, Stobo WT (2000) Shark-inflicted mortality on a population of harbour seals (*Phoca vitulina*) at Sable Island, Nova Scotia. *J Zool* 252:405–414. doi:10.1017/S0952836900000157
- Lumaret JP, Errouissi F, Floate K, Römbke J, Wardhaugh K (2012) A review on the toxicity and non-target effects of macrocyclic lactones in terrestrial and aquatic

environments. *Curr Pharm Biotechnol* 13:1004–1060.
doi:10.2174/138920112800399257

Lynch M (1999) Pinnipeds – anaesthesia, medicine and surgery. In: *Wildlife in Australia: health care and management*, Western Plains Zoo, Dubbo, 13–17 September. Post Graduate Foundation in Veterinary Science, University of Sydney, Proceedings no. 327, pp 81–96

Lyons ET, Keyes MC, Conlogue J (1978) Activities of dichlorvos or disophenol against the hookworm (*Uncinaria lucasi*) and sucking lice of northern fur seal pups (*Callorhinus ursinus*) on St. Paul Island, Alaska. *J Wildl Dis* 14:455–464.
doi:10.7589/0090-3558-14.4.455

Lyons ET, Kim KC, Keyes MC (1980) Variable activity of disophenol against hookworms and lice of northern fur seal pups on St. Paul Island, Alaska. *J Wildl Dis* 16:53–57.
doi:10.7589/0090-3558-16.1.53

Lyons ET, Keyes MC (1984) Further indication of viability of larvae of the hookworm (*Uncinaria lucasi*) for several years in tissues of northern fur seals (*Callorhinus ursinus*). *J Parasitol* 70:459–460. doi:10.2307/3281589

Lyons ET (1994) Vertical transmission of nematodes: emphasis on *Uncinaria lucasi* in northern fur seals and *Strongyloides westeri* in equids. *J Helminthol Soc Wash* 61:169–178

Lyons ET, DeLong RL, Melin SR, Tolliver SC (1997) Uncinariasis in northern fur seal and California sea lion pups from California. *J Wildl Dis* 33:848–852.
doi:10.7589/0090-3558-33.4.848

Lyons ET, DeLong RL, Gulland FMD, Melin SR, Tolliver SC, Spraker TR (2000a) Comparative biology of *Uncinaria* spp. in the California sea lion (*Zalophus*

- californianus*) and the northern fur seal (*Callorhinus ursinus*) in California. J Parasitol 86:1348–1352. doi:10.2307/3285025
- Lyons ET, Spraker TR, Olson KD, Tolliver SC, Bair HD (2000b) Prevalence of hookworms (*Uncinaria lucasi* Stiles) in northern fur seal (*Callorhinus ursinus* Linnaeus) pups on St. Paul Island, Alaska, U.S.A.: 1986–1999. Comp Parasitol 67:218–223
- Lyons ET, Melin SR, DeLong RL, Orr AJ, Gulland FMD, Tolliver SC (2001) Current prevalence of adult *Uncinaria* spp. in northern fur seal (*Callorhinus ursinus*) and California sea lion (*Zalophus californianus*) pups on San Miguel Island, California, with notes on the biology of these hookworms. Vet Parasitol 97:309–318. doi:10.1016/S0304-4017(01)00418-6
- Lyons ET, DeLong RL, Spraker TR, Melin SR, Tolliver SC (2003) Observations in 2001 on hookworms (*Uncinaria* spp.) in otariid pinnipeds. Parasitol Res 89:503–505. doi:10.1007/s00436-002-0784-3
- Lyons ET, DeLong RL (2005) Photomicrographic images of some features of *Uncinaria* spp (Nematoda: Ancylostomatidae) from otariid pinnipeds. Parasitol Res 95:346–352. doi:10.1007/s00436-005-1308-8
- Lyons ET, DeLong RL, Spraker TR, Melin SR, Laake JL, Tolliver SC (2005) Seasonal prevalence and intensity of hookworms (*Uncinaria* spp.) in California sea lion (*Zalophus californianus*) pups born in 2002 on San Miguel Island, California. Parasitol Res 96:127–132. doi:10.1007/s00436-005-1335-5
- Lyons ET, DeLong RL, Nadler SA, Laake JL, Orr AJ, DeLong BL, Pagan C (2011a) Investigations of peritoneal and intestinal infections of adult hookworms (*Uncinaria* spp.) in northern fur seal (*Callorhinus ursinus*) and California sea lion

- (*Zalophus californianus*) pups on San Miguel Island, California (2003). *Parasitol Res* 109:581–589. doi:10.1007/s00436-011-2289-4
- Lyons ET, Spraker TR, DeLong RL, Ionita M, Melin SR, Nadler SA, Tolliver SC (2011b) Review of research on hookworms (*Uncinaria lucasi* Stiles, 1901) in northern fur seals (*Callorhinus ursinus* Linnaeus, 1758). *Parasitol Res* 109:257–265. doi:10.1007/s00436-011-2420-6
- Lyons ET, Kuzmina TA, Spraker TR, Jaggi N, Costa DP, Crocker DE, Tift MS (2012a) Parasitological examination for presence of hookworms (*Uncinaria* spp.) in northern elephant seals (*Mirounga angustirostris*) at Año Nuevo State Reserve, California (2012). *Parasitol Res* 111:1847–1850. doi:10.1007/s00436-012-2919-5
- Lyons ET, Kuzmina TA, Tolliver SC, Spraker TR (2012b) Update on the prevalence of the hookworm, *Uncinaria lucasi*, in northern fur seals (*Callorhinus ursinus*) on St. Paul Island, Alaska, 2011. *Parasitol Res* 111:1397–1400. doi:10.1007/s00436-012-2881-2
- Maplestone PA (1939) A new species of *Uncinaria* Fröhlich, 1789 (Nematoda), with a note on *U. stenocephala* (Railliet, 1884). *Rec Indian Mus* 41:219–222
- Marlow BJ (1975) The comparative behaviour of the Australasian sea lions *Neophoca cinerea* and *Phocarctos hookeri* (Pinnipedia: Otariidae). *Mammalia* 39:159–230. doi:10.1515/mamm.1975.39.2.159
- McIntosh RR, Page B, Goldsworthy SD (2006a) Dietary analysis of regurgitates and stomach samples from free-living Australian sea lions. *Wildl Res* 33:661–670. doi:10.1071/WR06025
- McIntosh RR, Shaughnessy PD, Goldsworthy SD (2006b) Mark-recapture estimates of pup production for the Australian sea lion (*Neophoca cinerea*) at Seal Bay Conservation Park, South Australia. In: Trites AW, Atkinson SK, DeMaster DP, Fritz LW, Gelatt

- TS, Rea LD, Wynne KM (eds) Sea lions of the world, Alaska Sea Grant College Program: Fairbanks, Alaska. pp 353–367
- McIntosh RR (2007) Life history and population demographics of the Australian sea lion. PhD Dissertation, La Trobe University
- McIntosh RR, Murray MD (2007) Louse infestations of the Australian sea lion *Neophoca cinerea*. Aust Mammal 29:103–106. doi:10.1071/AM07014
- McIntosh RR, Goldsworthy SD, Shaughnessy PD, Kennedy CW, Burch P (2012) Estimating pup production in a mammal with an extended and aseasonal breeding season, the Australian sea lion (*Neophoca cinerea*). Wildl Res 39:137–148. doi:10.1071/WR10222
- McIntosh RR, Arthur AD, Dennis TE, Berris M, Goldsworthy SD, Shaughnessy PD, Teixeira CEP (2013) Survival estimates for the Australian sea lion: negative correlation of sea surface temperature with cohort survival to weaning. Mar Mamm Sci 29:84–108. doi:10.1111/j.1748-7692.2011.00558.x
- McIntosh RR, Kennedy CW (2013) Morphology, sex ratio and cause of death in Australian sea lion (*Neophoca cinerea*) pups. Aust Mammal 35:93–100. doi:10.1071/AM12037
- Melin SR, Orr AJ, Harris JD, Laake JL, DeLong RL, Gulland FMD, Stoudt S (2010) Unprecedented mortality of California sea lion pups associated with anomalous oceanographic conditions along the central California coast in 2009. Calif Coop Oceanic Fish Investig Rep 51:182–194
- Mizuno A (1997) Ecological study on the hookworm, *Uncinaria lucasi*, of northern fur seal, *Callorhynchus ursinus*, in bering island, russia. Jpn J Vet Res 45:109–110
- Nadler SA, Adams BJ, Lyons ET, DeLong RL, Melin SR (2000) Molecular and morphometric evidence for separate species of *Uncinaria* (Nematoda:

- Ancylostomatidae) in California sea lions and northern fur seals: hypothesis testing
supplants verification. *J Parasitol* 86:1099–1106. doi:10.1645/0022-
3395(2000)086[1099:MAMEFS]2.0.CO;2
- Nadler SA, Lyons ET, Pagan C, Hyman D, Lewis EE, Beckmen KB, Bell CM, Castinel A,
DeLong RL, Duignan PJ, Farinpour C, Huntington KB, Kuiken T, Morgades D,
Naem S, Norman R, Parker C, Ramos PW, Spraker TR, Berón-Vera B (2013)
Molecular systematics of pinniped hookworms (Nematoda: *Uncinaria*): species
delimitation, host associations and host-induced morphometric variation. *Int J*
Parasitol 43:1119–1132. doi:10.1016/j.ijpara.2013.08.006
- Nakagawa S, Schielzeth H (2013) A general and simple method for obtaining R^2 from
generalized linear mixed-effects models. *Methods Ecol Evol* 4:133–142.
doi:10.1111/j.2041-210x.2012.00261.x
- Needham DJ, Cargill CF, Sheriff D (1980) Haematology of the Australian sea lion,
Neophoca cinerea. *J Wildl Dis* 16:103–107. doi:10.7589/0090-3558-16.1.103
- Nicholson A, Fanning JC (1981) Parasites and associated pathology of the respiratory tract
of the Australian sea lion: *Neophoca cinerea*. In: Wildlife diseases of the Pacific
Basin and Other Countries. The 4th International Conference of the Wildlife
Disease Association, Sydney, August 25–28. pp 178–181
- Norman R (1994) Pathology and ecology of hookworm (*Uncinaria* sp.) infection in a new
seal host: the Australian fur seal. In: Proceedings of the Wildlife Disease
Association Annual Conference, Dubbo, September 24–25. p 29
- Olsen OW (1952) Report on investigations of hookworms, *Uncinaria lucasi* Stiles, 1901,
and hookworm disease of fur seals, *Callorhinus ursinus*, on the Pribilof Islands,
Alaska, from 7 July to September 2, 1951. With a supplemental report by W.L.

- Jellison, ozalid copy. US Department of Interior, Fish and Wildlife Service, Washington. (Cited after Lyons 2005)
- Olsen OW (1958) Hookworms, *Uncinaria lucasi* Stiles, 1901, in fur seals, *Callorhinus ursinus* (Linn.), on the Pribilof Islands. In: Trefethen JB (ed) Transactions of the twenty-third North American wildlife conference, St. Louis, Missouri, 3–5 March. pp 152–175
- Olsen OW, Lyons ET (1965) Life cycle of *Uncinaria lucasi* Stiles, 1901 (Nematoda: Ancylostomatidae) of fur seals, *Callorhinus ursinus* Linn., on the Pribilof Islands, Alaska. J Parasitol 51:689–700. doi:10.2307/3276141
- Olsen OW (1968) *Uncinaria rauschi* (Strongyloidea: Nematoda), a new species of hookworms from Alaskan bears. Can J Zool 46:1113–1117. doi:10.1139/z68-159
- Oxley APA, McKay DB (2004) Fecal shedding of *Helicobacter* spp. by co-housed Australian sea lions (*Neophoca cinerea*) and Australian fur seals (*Arctocephalus pusillus doriferus*). Vet Microbiol 101:235–243. doi:10.1016/j.vetmic.2004.03.022
- Oxley APA, Powell M, McKay DB (2004) Species of the family *Helicobacteraceae* detected in an Australian sea lion (*Neophoca cinerea*) with chronic gastritis. J Clin Microbiol 42:3505–3512. doi:10.1128/jcm.42.8.3505-3512.2004
- Pacioni C, Robertson ID, Maxwell M, van Weenen J, Wayne AF (2013) Hematologic characteristics of the woylie (*Bettongia penicillata ogilbyi*). J Wildl Dis 49:816–830. doi:10.7589/2011-09-275
- Page B, McKenzie J, McIntosh RR, Baylis AMM, Morrissey A, Calvert N, Haase T, Berris M, Dowie D, Shaughnessy PD (2004) Entanglement of Australian sea lions and New Zealand fur seals in lost fishing gear and other marine debris before and after Government and industry attempts to reduce the problem. Mar Pollut Bull 49:33–42. doi:10.1016/j.marpolbul.2004.01.006

- Page B, McKenzie J, Goldsworthy SD (2005) Dietary resource partitioning among sympatric New Zealand and Australian fur seals. *Mar Ecol Prog Ser* 293:283–302. doi:10.3354/meps293283
- Pérez-Ponce de León G, Nadler SA (2010) What we don't recognize can hurt us: a plea for awareness about cryptic species. *J Parasitol* 96:453–464. doi:10.1645/ge-2260.1
- Peters KJ, Ophelkeller K, Bott NJ, Deagle BE, Jarman SN, Goldsworthy SD (2014) Fine-scale diet of the Australian sea lion (*Neophoca cinerea*) using DNA-based analysis of faeces. *Mar Ecol*. doi:10.1111/maec.12145
- Phillips PH, Davenport PK, Schultz DJ (1986) *Microsporium gypseum* dermatophytosis in captive Australian Sea Lions, *Neophoca cinerea*. *J Zoo An Med* 17:136–138. doi:10.2307/20094807
- Poulin R (1997) Population abundance and sex ratio in dioecious helminth parasites. *Oecologia* 111:375–380. doi:10.1007/s004420050248
- Pritchard DI, Quinnell RJ, Walsh EA (1995) Immunity in humans to *Necator americanus*: IgE, parasite weight and fecundity. *Parasite Immunol* 17:71–75. doi:10.1111/j.1365-3024.1995.tb00968.x
- Ramos PW (2013) Investigation of hookworm (*Uncinaria* sp.) parasites in free-ranging Australian fur seals (*Arctocephalus pusillus doriferus*). Masters Dissertation, The University of Melbourne
- Ramos PW, Lynch M, Hu M, Arnould JPY, Norman R, Beveridge I (2013) Morphometric and molecular characterization of the species of *Uncinaria* Frölich, 1789 (Nematoda) parasitic in the Australian fur seal *Arctocephalus pusillus doriferus* (Schreber), with notes on hookworms in three other pinniped hosts. *Syst Parasitol* 85:65–78. doi:10.1007/s11230-013-9407-x

- Ransom BH (1924) Hookworms of the genus *Uncinaria* of the dog, fox, and badger. Proc US Natl Mus 65:1–5. doi:10.5479/si.00963801.65-2533.1
- Rea LD, Castellini MA, Fadely BS, Loughlin TR (1998) Health status of young Alaska Steller sea lion pups (*Eumetopias jubatus*) as indicated by blood chemistry and hematology. Comp Biochem Physiol A 120:617–623. doi:10.1016/S1095-6433(98)10074-0
- Rep BH (1963) On the polyxenias of the *Ancylostomidae* and the validity of the characters used for their differentiation. Trop Geogr Med 15:173–218
- Richmond JP, Burns JM, Rea LD, Mashburn KL (2005) Postnatal ontogeny of erythropoietin and hematology in free-ranging Steller sea lions (*Eumetopias jubatus*). Gen Comp Endocrinol 141:240–247. doi:10.1016/j.ygcn.2005.01.004
- Rogerson JD, Fairbanks WS, Cornicelli L (2008) Ecology of gastropod and bighorn sheep hosts of lungworm on isolated, semiarid mountain ranges in Utah, USA. J Wildl Dis 44:28–44. doi:10.7589/0090-3558-44.1.28
- Ronquist F, Teslenko M, van der Mark P, Ayres DL, Darling A, Höhna S, Larget B, Liu L, Suchard MA, Huelsenbeck JP (2012) MrBayes 3.2: efficient bayesian phylogenetic inference and model choice across a large model space. Syst Biol 61:539–542. doi:10.1093/sysbio/sys029
- Sajid MS, Iqbal Z, Muhammad G, Iqbal MU (2006) Immunomodulatory effect of various anti-parasitics: a review. Parasitology 132:301–313. doi:10.1017/S0031182005009108
- Schmertmann L (2010) Investigating aspects of health and disease in Australian sea lion, *Neophoca cinerea*, pups: haematology and protein analysis. Honours Dissertation, The University of Sydney

- Schwacke LH, Hall AJ, Townsend FI, Wells RS, Hansen LJ, Hohn AA, Bossart GD, Fair PA, Rowles TK (2009) Hematologic and serum biochemical reference intervals for free-ranging common bottlenose dolphins (*Tursiops truncatus*) and variation in the distributions of clinicopathologic values related to geographic sampling site. *Am J Vet Res* 70:973–985. doi:10.2460/ajvr.70.8.973
- Seguel M, Paredes E, Pavés H, Molina R, Henríquez F, De Groote F, Schlatter R (2011) Pathological findings in South American fur seal pups (*Arctocephalus australis gracilis*) found dead at Guafo Island, Chile. *J Comp Pathol* 145:308–317. doi:10.1016/j.jcpa.2011.01.006
- Seguel M, Paredes E, Pavés H, Gottdenker NL (2013a) Capture-induced stress cardiomyopathy in South American fur seal pups (*Arctophoca australis gracilis*). *Mar Mamm Sci* 30:1149–1157. doi:10.1111/mms.12079
- Seguel M, Pavés H, Paredes E, Schlatter R (2013b) Causes of mortality in South American fur seal pups (*Arctophoca australis gracilis*) at Guafo Island, southern Chile (2004–2008). *Mar Mamm Sci* 29:36–47. doi:10.1111/j.1748-7692.2011.00534.x
- Sepúlveda MS, Alcaíno H (1993) Helminthological fauna of the Juan Fernandez fur seal, *Arctocephalus philippii* (Peters, 1866). *Parasitol Dia* 17:19–24
- Sepúlveda MS (1998) Hookworms (*Uncinaria* sp.) in Juan Fernandez fur seal pups (*Arctocephalus philippii*) from Alejandro Selkirk Island, Chile. *J Parasitol* 84:1305–1307. doi:10.2307/3284700
- Sepúlveda MS, Ochoa-Acuña H, Homer BL (1999) Age-related changes in hematocrit, hemoglobin, and plasma protein in Juan Fernandez fur seals (*Arctocephalus philippii*). *Mar Mamm Sci* 15:575–581. doi:10.1111/j.1748-7692.1999.tb00824.x

- Sergent N, Rogers T, Cunningham M (2004) Influence of biological and ecological factors on hematological values in wild little penguins, *Eudyptula minor*. *Comp Biochem Physiol A* 138:333–339. doi:10.1016/j.cbpb.2004.04.011
- Shaughnessy PD, Dennis TE, Seager PG (2005) Status of Australian sea lions, *Neophoca cinerea*, and New Zealand fur seals, *Arctocephalus forsteri*, on Eyre Peninsula and the far west coast of South Australia. *Wildl Res* 32:85–101. doi:10.1071/WR03068
- Shaughnessy PD, Dennis TE, Berris M (2007) Predation on Australian sea lions *Neophoca cinerea* by white sharks *Carcharodon carcharias* in South Australia. *Aust Mammal* 29:69–75. doi:10.1071/AM07008
- Shaughnessy PD, McKenzie J, Lancaster ML, Goldsworthy SD, Dennis TE (2010) Australian fur seals establish haulout sites and a breeding colony in South Australia. *Aust J Zool* 58:94–103. doi:10.1071/ZO10017
- Shaughnessy PD, Goldsworthy SD, Hamer DJ, Page B, McIntosh RR (2011) Australian sea lions *Neophoca cinerea* at colonies in South Australia: distribution and abundance, 2004 to 2008. *Endanger Species Res* 13:87–98. doi:10.3354/esr00317
- Shaughnessy PD, Goldsworthy SD, Burch P, Dennis TE (2013) Pup numbers of the Australian sea lion (*Neophoca cinerea*) at The Pages Islands, South Australia, over two decades. *Aust J Zool*:112–118. doi:10.1071/ZO13015
- Shaughnessy PD, Goldsworthy SD (2014) Long-nosed fur seal: a new vernacular name for the fur seal, *Arctocephalus forsteri*, in Australia. *Mar Mamm Sci* 31:830–832. doi:10.1111/mms.12203
- Shaughnessy PD, Goldsworthy SD, Mackay AI (2014) Status and trends in abundance of New Zealand fur seal populations in South Australia. SARDI Publication Number F2014/000338-1. SARDI Research Report Series No. 781, Adelaide

- Shaughnessy PD, Goldsworthy SD, Mackay AI (2015) The long-nosed fur seal (*Arctocephalus forsteri*) in South Australia in 2013–14: abundance, status and trends. *Aust J Zool* 63:101–110. doi:10.1071/ZO14103
- Shaw JL, Moss R (1989) The role of parasite fecundity and longevity in the success of *Trichostrongylus tenuis* in low density red grouse populations. *Parasitology* 99:253–258. doi:10.1017/S0031182000058704
- Shi R, Conrad SA (2009) Correlation and regression analysis. *Ann Allergy Asthma Immunol* 103, Supplement 1:S35–S41. doi:10.1016/S1081-1206(10)60820-4
- Shimono Y, Taharaguchi S, Taira K, Miyoshi N, Yasuda N (2012) rDNA ITS sequences of *Uncinaria* spp. from Tsushima leopard cat (*Prionailurus bengalensis euptilura*). *Helminthologia* 49:123–127. doi:10.2478/s11687-012-0026-x
- Shoop WL (1991) Vertical transmission of helminths: hypobiosis and amphiparatensis. *Parasitol Today* 7:51–54. doi:10.1016/0169-4758(91)90189-U
- Simpson K (2014) Acute phase proteins and maternally and actively acquired IgG in Australian sea lion (*Neophoca cinerea*) pups with hookworm (*Uncinaria sanguinis*) infection. Honours Dissertation, The University of Sydney
- Šlapeta J (2013) Ten simple rules for describing a new (parasite) species. *Int J Parasitol Parasites Wildl* 2:152–154. doi:10.1016/j.ijppaw.2013.03.005
- Smales LR (1986) Polymorphidae (Acanthocephala) from Australian mammals with descriptions of two new species. *Syst Parasitol* 8:91–100. doi:10.1007/bf00009865
- Smith KF, Acevedo-Whitehouse K, Pedersen AB (2009) The role of infectious diseases in biological conservation. *Anim Conserv* 12:1–12. doi:10.1111/j.1469-1795.2008.00228.x

- Soto KH, Trites AW, Arias-Schreiber M (2004) The effects of prey availability on pup mortality and the timing of birth of South American sea lions (*Otaria flavescens*) in Peru. *J Zool* 264:419–428. doi:10.1017/S0952836904005965
- Spada E, Proverbio D, Della Pepa A, Domenichini G, Bagnagatti De Giorgi G, Traldi G, Ferro E (2013) Prevalence of faecal-borne parasites in colony stray cats in northern Italy. *J Feline Med Surg* 15:672–677. doi:10.1177/1098612x12473467
- Speare R, Canyon DV, Melrose W (2006) Quantification of blood intake of the head louse: *Pediculus humanus capitis*. *Int J Dermatol* 45:543–546. doi:10.1111/j.1365-4632.2005.02520.x
- Spraker TR, DeLong RL, Lyons ET, Melin SR (2007) Hookworm enteritis with bacteremia in California sea lion pups on San Miguel Island. *J Wildl Dis* 43:179–188. doi:10.7589/0090-3558-43.2.179
- Spraker TR, Lander ME (2010) Causes of mortality in northern fur seals (*Callorhinus ursinus*), St. Paul Island, Pribilof Islands, Alaska, 1986–2006. *J Wildl Dis* 46:450–473. doi:10.7589/0090-3558-46.2.450
- Spraker TR, Lyons ET, Kuzmina TA, Tift MS, Raverty S, Jaggi N, Crocker DE (2014) Causes of death in preweaned northern elephant seal pups (*Mirounga angustirostris*, Gill, 1866), Año Nuevo State Reserve, California, 2012. *J Vet Diagn Investig* 26:320–326. doi:10.1177/1040638714523427
- Springer AM, Estes JA, van Vliet GB, Williams TM, Doak DF, Danner EM, Forney KA, Pfister B (2003) Sequential megafaunal collapse in the North Pacific Ocean: An ongoing legacy of industrial whaling? *Proc Natl Acad Sci U S A* 100:12223–12228. doi:10.1073/pnas.1635156100
- Stiles CW, Hassall A (1899) Internal parasites of the fur seal. In: Jordan DS, Stejneger L, Lucas FA, Moser JF, Townsend CH, Clark GA, Murray J (eds) *The fur seals and*

- fur-seal islands of the North Pacific Ocean. Part 3: Special papers relating to the fur seal and to the natural history of the Pribilof islands. Government Printing Office, Washington, pp 99–177
- Stiles CW (1901) Uncinariasis (Ancylostomiasis) in man and animals in the United States. *Texas Med News* 10:523–532
- Stirling I (1972) Observations on the Australian sea lion, *Neophoca cinerea* (Peron). *Aust J Zool* 20:271–279. doi:10.1071/ZO9720271
- Stockham SL, Scott MA (2008) *Fundamentals of veterinary clinical pathology*. 2nd edn. Blackwell Publishing, Ames
- Stoye M (1973) Untersuchungen über die möglichkeit pränataler und galaktogener infektionen mit *Ancylostoma caninum* Ercolani 1859 (Ancylostomidae) beim hund. *Zbl Vet Med B* 20:1–39. doi:10.1111/j.1439-0450.1973.tb01098.x
- Stringer AP, Linklater W (2014) Everything in moderation: principles of parasite control for wildlife conservation. *Bioscience* 64:932–937. doi:10.1093/biosci/biu135
- Tamura K, Peterson D, Peterson N, Stecher G, Nei M, Kumar S (2011) MEGA5: molecular evolutionary genetics analysis using maximum likelihood, evolutionary distance, and maximum parsimony methods. *Mol Biol Evol* 28:2731–2739. doi:10.1093/molbev/msr121
- Taylor JM, Cumberland WG, Meng X, Giorgi JV (1996) Normal range estimation for repeated immunologic measures. *Clin Diagn Lab Immunol* 3:139–142
- Tee MH, Lee YY, Majid NA, Noori NM, Raj SM (2013) Growth reduction among primary school-children with light trichuriasis in Malaysia treated with albendazole. *Southeast Asian J Trop Med Public Health* 44:19–24

- Telfer S, Bennett M, Bown K, Cavanagh R, Crespín L, Hazel S, Jones T, Begon M (2002) The effects of cowpox virus on survival in natural rodent populations: increases and decreases. *J Anim Ecol* 71:558–568. doi:10.1046/j.1365-2656.2002.00623.x
- Telfer S, Bennett M, Bown K, Carslake D, Cavanagh R, Hazel S, Jones T, Begon M (2005) Infection with cowpox virus decreases female maturation rates in wild populations of woodland rodents. *Oikos* 109:317–322. doi:10.1111/j.0030-1299.2005.13734.x
- Thomas F, Poulin R, Guégan JF, Michalakis Y, Renaud F (2000) Are there pros as well as cons to being parasitized? *Parasitol Today* 16:533–536. doi:10.1016/S0169-4758(00)01790-7
- Thompson JD, Higgins DG, Gibson TJ (1994) CLUSTAL W: improving the sensitivity of progressive multiple sequence alignment through sequence weighting, position-specific gap penalties and weight matrix choice. *Nucleic Acids Res* 22:4673–4680. doi:10.1093/nar/22.22.4673
- Thompson PM, Corpe HM, Reid RJ (1998) Prevalence and intensity of the ectoparasite *Echinophthirius horridus* on harbour seals (*Phoca vitulina*): effects of host age and inter-annual variability in host food availability. *Parasitology* 117:393–403. doi:10.1017/S0031182098003072
- Thompson RCA, Lymbery AJ, Smith A (2010) Parasites, emerging disease and wildlife conservation. *Int J Parasitol* 40:1163–1170. doi:10.1016/j.ijpara.2010.04.009
- Thorson PH, Le Boeuf BJ (1994) Developmental aspects of diving in northern elephant seal pups. In: Le Boeuf BJ, Laws RM (eds) *Elephant seals: population ecology, behavior, and physiology*. University of California Press, Berkeley, pp 271–289
- Tompkins DM, Dunn AM, Smith MJ, Telfer S (2011) Wildlife diseases: from individuals to ecosystems. *J Anim Ecol* 80:19–38. doi:10.1111/j.1365-2656.2010.01742.x

- Trillmich F, Rea LD, Castellini MA, Wolf JBW (2008) Age-related changes in hematocrit in the Galápagos sea lion (*Zalophus wollebaeki*) and the Weddell seal (*Leptonychotes weddellii*). *Mar Mamm Sci* 24:303–314. doi:10.1111/j.1748-7692.2007.00177.x
- Trumble SJ, Castellini MA (2002) Blood chemistry, hematology, and morphology of wild harbor seal pups in Alaska. *J Wildl Manage* 66:1197–1207. doi:10.2307/3802953
- Tukey JW (1977) *Exploratory data analysis*. Addison-Wesley Publishing Company, Reading
- Twisleton-Wykeham-Fiennes RN (1966) The Zoological Society of London Report of the Society's Pathologist for the year 1963. *J Zool* 148:341–362. doi:10.1111/j.1469-7998.1966.tb02955.x
- Van Oers K, Heg D, Le Drean Quenec'hdu S (2002) Anthelmintic treatment negatively affects chick survival in the Eurasian Oystercatcher *Haematopus ostralegus*. *Ibis* 144:509–517. doi:10.1046/j.1474-919X.2002.00078.x
- Vercruysse J, Salomez A, Ulloa A, Osterhaus A, Kuiken T, Alvinerie M (2003) Efficacy of ivermectin and moxidectin against *Otostrongylus circumlitus* and *Parafilaroides gymnurus* in harbour seals (*Phoca vitulina*). *Vet Rec* 152:130–134. doi:10.1136/vr.152.5.130
- Vicente J, Fernández de Mera IG, Gortazar C (2006) Epidemiology and risk factors analysis of elaphostrongylosis in red deer (*Cervus elaphus*) from Spain. *Parasitol Res* 98:77–85. doi:10.1007/s00436-005-0001-2
- Walker MJ, Jacobs DE (1982) Epidemiology of *Uncinaria stenocephala* infections in greyhound breeding kennels. *Vet Parasitol* 10:317–321. doi:10.1016/0304-4017(82)90083-8

- Willmott S, Chabaud AG (2009) Glossary and keys to subclasses. In: Anderson RC, Chabaud AG, Willmott S (eds) Keys to the nematode parasites of vertebrates: archival volume. CABI, Oxfordshire, pp 1–17
- Wimsatt J, O'Shea TJ, Ellison LE, Pearce RD, Price VR (2005) Anesthesia and blood sampling of wild big brown bats (*Eptesicus fuscus*) with an assessment of impacts on survival. *J Wildl Dis* 41:87–95. doi:10.7589/0090-3558-41.1.87
- Woon S (2012) Transdermal penetration of avermectins in Australian sea lion (*Neophoca cinerea*) pups. Honours Dissertation, The University of Sydney
- Yazdanbakhsh M, Kremsner PG, van Ree R (2002) Allergy, parasites, and the hygiene hypothesis. *Science* 296:490–494. doi:10.1126/science.296.5567.490