



COPYRIGHT AND USE OF THIS THESIS

This thesis must be used in accordance with the provisions of the Copyright Act 1968.

Reproduction of material protected by copyright may be an infringement of copyright and copyright owners may be entitled to take legal action against persons who infringe their copyright.

Section 51 (2) of the Copyright Act permits an authorized officer of a university library or archives to provide a copy (by communication or otherwise) of an unpublished thesis kept in the library or archives, to a person who satisfies the authorized officer that he or she requires the reproduction for the purposes of research or study.

The Copyright Act grants the creator of a work a number of moral rights, specifically the right of attribution, the right against false attribution and the right of integrity.

You may infringe the author's moral rights if you:

- fail to acknowledge the author of this thesis if you quote sections from the work
- attribute this thesis to another author
- subject this thesis to derogatory treatment which may prejudice the author's reputation

For further information contact the University's Director of Copyright Services

sydney.edu.au/copyright

Cognitive Bias, Personality and Arousal in the Domestic Dog

by

Melissa Jane Starling

B.Sc. (Hons.)

A thesis submitted in fulfilment of the requirements for the degree of

DOCTOR OF PHILOSOPHY

Faculty of Veterinary Science
The University of Sydney

2013



COPYRIGHT AND USE OF THIS THESIS

This thesis must be used in accordance with the provisions of the Copyright Act 1968.

Reproduction of material protected by copyright may be an infringement of copyright and copyright owners may be entitled to take legal action against persons who infringe their copyright.

Section 51 (2) of the Copyright Act permits an authorized officer of a university library or archives to provide a copy (by communication or otherwise) of an unpublished thesis kept in the library or archives, to a person who satisfies the authorized officer that he or she requires the reproduction for the purposes of research or study.

The Copyright Act grants the creator of a work a number of moral rights, specifically the right of attribution, the right against false attribution and the right of integrity.

You may infringe the author's moral rights if you:

- fail to acknowledge the author of this thesis if you quote sections from the work
- attribute this thesis to another author
- subject this thesis to derogatory treatment which may prejudice the author's reputation

For further information contact the University's Director of Copyright Services

sydney.edu.au/copyright

Declaration

I hereby declare that this thesis is my own work, and that, to the best of my knowledge, it is original and contains no material previously published or written by another person except where due acknowledgment has been made in the text. Any help received in preparing this thesis, and all sources used, have been acknowledged.

I certify that this submission has not been submitted for any degree or qualification at the University of Sydney or other institute of higher learning.

Melissa Starling

4th July 2013

Acknowledgements

The past three-and-a-half years have been a journey the breadth of which I had no real comprehension of when I first began it. I could not have completed it without the help and support of many, many people, and I am eternally grateful for their contributions and for this opportunity to acknowledge them.

Of course, I must start with my supervisors. I have heard it said that a supervisor can make or break a project, and I believe it. I have been very fortunate to have Paul McGreevy as my primary supervisor. I was dubious about working on cognitive bias for approximately the first five minutes of him explaining it to me, and then my curiosity was piqued and that was that. Paul let me loose on it, allowed me make it my own, encouraged my feasible ideas and gently guided me away from my more wild ideas. He never once dampened my enthusiasm, but was always there to help me shape the development of my project to where my passions and interests naturally took me. He has been exactly the right kind of supervisor for me.

My associate supervisor, Nick Branson, was also a joy to work with. Just when I thought I had my head around something he would be there with a different perspective, a deeper understanding, and new criticisms. I am a passionate writer, and Nick's comments on my written work have always been detailed and pertinent, and have driven my writing to new heights. I still have some way to go to be the excellent scientific writer I strive to be, but Nick has certainly pushed me further towards my goals.

My family has been tremendous, and without their ongoing and unflagging support I would have had to settle for a much more ordinary project. My older brother, Tim, offered to help me build my apparatus. I don't think he imagined just how much work would be involved, or that the University had no workshops I could access. In addition, the project had no budget, so we turned his dining room into a workshop and built it all from scratch in whatever time he could

produce between a full-time job and a new baby. My Dad also made a heroic effort on my behalf, building the hardware to house the electronics Tim was working on. He spent many hours tinkering and solving problems with the design, and probably lost sleep over it.

Many people made smaller, but still significant contributions, and some of them donated their time and resources even though they barely knew me. Kate Finlayson bravely took on the first pilot study and wrote an impressive honours thesis detailing how the first version of the apparatus could be improved. Mr Finlayson, Kate's father, built a beautiful wooden box to house it and serve as a base, mounted the electronics, and solved many problems we had been wrestling with. Ken Logan, the man who runs the medical supplies warehouse behind my dad's shop, solved my liquid delivery and reservoir problems and custom made some tubes and connectors for me at no cost. Warren Townsend from Black Dog Wear Pty. Ltd. generously donated funds to the project early on.

I was fortunate to have the cooperation of Barbara Wright and Sue Dingwall and the crew at Positive Puppies, who put me in contact with many of their clients and thus organised access to many dogs. They also generously paid for the final version of the apparatus, and contributed financially to my fuel costs so I could get to the other side of Sydney every day. Their interest and enthusiasm for my project were unprecedented, and Barbara's organisational skills are phenomenal.

The trainers at Assistance Dogs Australia were fantastic. They bent over backwards to accommodate me. Despite being very busy, they were always prompt in answering my queries, returning forms, and filling out surveys for me. Their cooperation was complete and unwavering, and I developed a deep fondness for them, their dogs, and their organisation. Veronica and Bruno Grutzner at Schutzhund Security Solutions also generously allowed me unfettered access to their dogs and were extremely cooperative.

I was blessed to have the help of Peter Thomson in analysing my data. When I started my project I knew almost nothing about statistics and was almost phobic about maths. Peter was unendingly patient with me, giving me time when he had little of it to spare, and checking my R code and my statistics reporting whenever I asked. Under his guidance, I learned to be excited about numbers and maths for the first time in my life. I also had the benefit of Denis Cody's help when it came to non-statistical interpretations of my data. I have really enjoyed learning about my data from the perspective of an engineer/mathematician, and if it weren't for him I would still be looking at it in terms of p-values and struggling with what to do with it all.

Lastly, I would like to acknowledge the emotional support of friends and family. This PhD has been an amazing, but at times very stressful, journey. My partner, Grant, has shared all the ups and downs, been there to put things in perspective, and I don't know where I'd be without him. My mother, as always, was a sympathetic ear and never grew bored of listening to how my project was going. And, of course, my own dogs Kivi Tarro and Erik the Tall, who were the original inspiration for me to abandon wildlife research and turn to dogs. They let me test ideas on them, and probably nothing short of their cute faces turning up all of a sudden because they had unanimously and spontaneously decided it was time I took them to the park could have dragged me away from the computer for much-needed breaks.

Abstract

The domestic dog has lived alongside humankind for at least the last 14 000 years, and in that time has undergone many changes in morphology and behaviour. Selective breeding has produced a species with a huge range in body size, shape, coat type and colour, and inherent behavioural responses related to specific jobs they have been bred for. Increasingly, there is evidence to suggest our close and enduring relationship may have resulted in some inherent inter-specific understanding. Concurrently, inter-specific misunderstandings can underlie major issues that rupture the usually harmonious relationship between the two species. This can go both ways. Many natural human behaviours may cause dogs to feel frightened or threatened, and prompt aggressive behaviour directed towards humans that may result in human injury, and in some cases the subsequent euthanasia of the dog. On a more subtle level, there is a long history of dogs being trained for work, sport or leisure, and whether the dog enjoys this may not always be considered. Such oversight relating to the dog's perspective may extend to husbandry practices and the living conditions dogs experience under our care. Animal welfare is increasingly on the social conscience and provides a fertile bed for investigating the dog half of the dog-human dyad in a new light. For example, questions are now being considered such as what makes dogs "happy", and how can positive and negative emotional experiences be measured so we can explore canine needs? This thesis aims to lay the foundations for examining the emotional lives of dogs in a scientifically rigorous way, and outline how this may help us better understand and therefore better predict how dogs behave and how they react to us.

Chapter 1 will review the literature associated with how dogs behave in the dog-human dyad and then move on to how dog personality traits are assessed and interpreted, in the context of increasing our understanding of dog behaviour. It will also describe what is known about emotional states in animals and how arousal and emotional valence may influence behaviour.

Chapter 2 will explore theoretically the complex and variable nature of the dog-human dyad. It highlights the disparity between ethology and psychology in interpreting dog behaviour and investigate the way this impacts on humans' behaviour towards dogs. It may be attractive to dog owners and trainers to attempt to communicate with dogs the way they communicate with each other, but realistically this may be of limited use. The very fact that humans are bipedal and dogs are quadrupedal offers some significant difficulties. A scientific approach to interacting with dogs would ideally incorporate a balance between learning theory and objective measures of ethology. However, such a balance can at times be elusive and difficult to quantify. It is acknowledged that some peoples' natural aptitude may provide the means to quantify this balance by identifying what behaviours they perform that assist them in communicating effectively with the dogs they train and efficiently, creating animals that respond quickly and reliably to cues. This effective communication and reliable responses might be considered "dogmanship", the way that skilled handling of horses is considered "horsemanship". Studying such a process is likely to facilitate discussion of different handling approaches and why some may be more effective, relevant and humane than others, while also opening up so-called horse or dog "whispering" techniques to critical analysis. The Chapter illuminates the mismatch between nonverbal signals used by humans and dogs during their interactions with each other by way of an interspecific and intraspecific canid ethogram, offering a framework for studying dogmanship in the future.

Chapters 3 and 4 will lead on from this, exploring dog personality through a large dataset collected through a survey for dog owners. The study investigated "Boldness" in dogs, which is believed to be one end of the shy-bold axis, a super-trait that is recognised in a range of taxa. The super-trait influences a suite of personality traits. Previous studies have found that boldness in dogs is affected by breed and breed groups, and is affected in some cases by the sex of the dogs. It has also been shown to have an influence on performance in sporting dogs. Chapter 3 presents a published manuscript reporting on the differences in the expression of boldness among dog breeds, kennel club breed groups, and sub-

groups of kennel club breed groups. Breed and breed group had a significant effect on boldness. Herding and gundog groups were broken into sub-groups based on historic breed purpose. Retrievers were significantly bolder than flushing breeds, and tending and loose-eyed herding breeds were bolder than cattle-herding breeds. This study supported the existence of the shy-bold axis in dogs. Differences in boldness among groups did not exactly match those reported in previous studies, suggesting that behavioural tendencies may be influenced by historical purpose regardless of whether that purpose continues to influence selective breeding. Differences in boldness between sub-groups seemed to support this. Chapter 4 presents a second published manuscript that reports on the relationships between boldness and age, sex, and reproductive status of dogs. Boldness decreased with age, males were bolder than females, and entire dogs were bolder than neutered dogs. This study showed how behaviour may change in adult dogs as they age and added to the literature on how sex and reproductive status may affect personality in dogs.

Chapter 5 explores judgement bias in animals as an aspect of personality in dogs that is only just entering into scientific discourse. Judgement bias has been shown to be a valid indicator of affective state in recent studies. When animals are in a positive affective state they judge ambiguous signals to indicate more positive outcomes than average (optimism), and when they are in a negative affective state they interpret ambiguous signals to indicate more negative outcomes (pessimism). There is some indication from studies on dogs, starlings, and capuchins that some individuals may be more prone to pessimism than others. It may also follow that some individuals are more prone to optimism than others, and still other individuals with a tendency to be balanced. Therefore, judgement bias may be used as an objective indicator of personality in animals as well as an indicator to evaluate the welfare impact of how humans interact with dogs in training, husbandry, and play (as described in Chapter 1). Chapter 5 outlines the development of an automated apparatus for testing judgement bias in dogs. Twenty dogs from different sources (public, service dog advanced training program, private security company) had their judgement bias tested with a go/no-go task for which dogs were trained to touch a target with their

nose after a positive signal and abstain from touching the target after a negative signal. Latency to touch the target was measured for positive, negative and nine ambiguous 'probe' signals. The results were interpreted via a mathematical model. Tipping points where average latency jumped by 100% or more showed dogs could discriminate between positive and negative signals and identified the point at which ambiguous tones were interpreted by the dog as more likely to predict a negative outcome than a positive outcome. Standard deviation was divided by average latency at each probe after the tipping point and added to give a variance score. A high variance score indicated dogs that treated some signals after the tipping point as positive signals whereas a low variance score indicated dogs that maintained a low response rate after the tipping point. This is a novel method for interpreting judgement bias data and gives a new insight into how optimism and pessimism may affect the way dogs behave.

Chapter 6 presents a submitted manuscript titled "A comparison of uniaxial and triaxial accelerometers for the assessment of physical activity in dogs" that describes a technique using activity monitors and pedometers to measure physical activity in dogs. Low physical activity is believed to be associated with negative emotional states, particularly anhedonia. A simple measure of physical activity may therefore be of use in validating judgement bias measures. Triaxial accelerometers have been validated in dogs as a means to measure physical activity. The study reported on in Chapter 6 compared the outputs of uniaxial and triaxial accelerometers to determine whether relatively cheap uniaxial accelerometers (UA) can substitute very expensive triaxial accelerometers (TA) to measure physical activity in dogs. Both a single UA and single TA were attached to the collars of 79 shelter dogs during free-living activity within the dog's kennel, and structured activities of different intensities guided by the experimenter. The difference in step counts between the two types of accelerometer were analysed through correlation and Bland-Altman agreement plots. UA were found to record significantly more steps than TA. Agreement between the units was highest in heavier dogs, lower step counts, and in structured activities. This is the first study to compare the use of uniaxial with triaxial accelerometers in measuring physical activity in dogs. The results show

the different types of accelerometer differ in the activity they record to the extent that they cannot be used interchangeably. This study also demonstrated that the weight of the dog may affect how much activity is recorded and how accurate that recording is. It is suggested that the more expensive triaxial accelerometers are more likely to provide data comparable across different activity types and different sizes and weights of dogs.

Chapter 7 presents a published manuscript titled “Conceptualising the Impact of Arousal and Affective State on Training Outcomes of Operant Conditioning” that discusses from a theoretical perspective how the data presented in Chapters 3, 4 and 5 may be applied to better predict training outcomes when using the principles of operant conditioning. This Chapter revisits some of the themes from Chapter 1 to examine them in the light of the data collected throughout the project. Animal training relies heavily on an understanding of species-specific behaviour as it integrates with operant conditioning principles. Recent studies have shown that affective states and arousal levels may correlate with behaviour outcomes. This manuscript explores the influence of both affective state and arousal on behavioural outcomes in the context of training animals using operant conditioning principles. A framework for assessing how affective state and arousal may influence the efficacy of operant training methods was presented in the form of a series of three-dimensional conceptual graphs to describe putative influences of both affective state and arousal on the likelihood of dogs and horses performing commonly desired behaviours. These graphs are referred to as response landscapes, and they highlight the flexibility available for improving training efficacy and the likely need for different approaches to suit animals in different affective states and at various levels of arousal.

Chapter 8 presents a submitted manuscript that leads on from the theoretical work in Chapter 7 with a review of the literature pertaining to safety signals and a critique of their potential use in the training and management of dogs and horses. Safety signals serve to lower arousal and reduce fear in the presence of aversive stimuli. As such, they may be pertinent to the response landscapes in Chapter 7 that show the negative effects of high arousal on training outcomes,

particularly when the animal is also experiencing negative affect. Chapter 8 may be viewed as laying the foundations for practical applications of the response landscapes. Safety signals may be useful both in singular training or management scenarios where it would be beneficial to lower arousal as well as building long-term relationships with animals based on positive affective state and moderate arousal.

The final chapter summarises the work compiled here and offers further discussion in the context of the broader issues such as understanding why dogs behave the way they do in a variety of situations relevant to us and how this may reflect their emotional well-being. The influence of personality on the variation seen in dog behaviour is also discussed in terms of possible future applications and future directions for this work.

A note on style

The papers presented in this thesis are unaltered from the versions that have been submitted or published to peer review journals except small edits to homogenise the formatting. Tables and figures have also been labelled to reflect the chapter they belong to. British spelling has been used throughout except where in a publication or journal title. The Harvard – Flinders referencing style has been adopted as recommended by the Faculty of Veterinary Science, University of Sydney.

List of Figures

Figure 3.1 Scree plot of Principle Components Analysis showing variances of the first ten components extracted. Only the first component was retained for further analysis. It accounts for 21.4% of the overall variance, but the scree plot clearly shows a large decline in the variance accounted for by components after the first component. The second and third components were examined for inclusion, but did not have strong loadings that suggested a theme.

Figure 3.2. Mean Boldness scores for UKC breed groups with error bars. Gua=Guardian group, Nor=Northern and Spitz, Gun=Gundog, Her=Herding, Ter=Terrier, Sig=Sighthound, Mix=Mixed breed, Sce=Scenthound, Com=Companion. Groups significantly bolder than the reference group (Companion) are marked with an asterisk: '*' denotes a significance level of <0.05, '**' a significance level of <0.005, and '***' a significance level of <0.001. The statistical model used was the 'lm' and 'lme' function in the statistical package R, and models were tested using the ANOVA function in R and the AIC value.

Figure 3.3. Effect of herding style on Boldness scores within the herding group. "Drive" is the reference group and refers to cattle herding breeds, "Head" to breeds with hard eye and a low herding stance, "Loose" to breeds with an upright herding stance and loose eye, and "Tending" to breeds developed to keep herds together in the one place. Significance in relation to the reference group is marked with asterisks. '*' Denotes a significance level of <0.05, '**' a significance level of <0.005. The statistical model used was the 'lm' and 'lme' function in the statistical package R, and models were tested using the ANOVA function in R and the AIC value.

Figure 3.4. Effect of specific gundog purpose on Boldness scores within the gundog group. "Flushing" is the reference group and refers to setters and spaniels, "Pointing" refers to pointing breeds, "HPR" refers to hunting, pointing, retrieving breeds bred as multi-purpose gundogs, and "Retriever" refers to retrieving breeds. Significance is measured in relation to the reference group. '***' denotes a significance level of <0.001. The statistical model used was the 'lm' and 'lme' function in the statistical package R, and models were tested using the ANOVA function in R and the AIC value.

Figure 4.1. Association between boldness and age in dogs using a spline function. Boldness decreases as age decreases. The statistical model used was the 'lm' and 'lme' function in the statistical package R, and models were tested using the 'anova' function in R and the AIC value.

Figure 4.2. a) shows boldness in male versus female dogs. Boldness scores as extracted from the first component of a principal component analysis is significantly greater in males than in females. The statistical model used was the 'lm' and 'lme' function in the statistical package R, and models were tested using the 'anova' function in R and the AIC value. **b)** shows boldness in entire versus desexed dogs of both sexes. Boldness scores as extracted from the first component of a principal component analysis are significantly greater in entire than in neutered dogs of both sexes.

Figure 5.1. A diagram of the apparatus used in the study. A = target, b = milk and water trays, c = photointerruptor shown with a red line.

Figure 5.2. The risk of touching the target before the 10-second time out for all cues is shown on the y-axis in a log scale, and individual dogs (n=20) are shown on the x-axis. Standard errors are shown with broken lines. Some dogs are much more likely to touch the target than others. For example, dogs "Ab", "Bi" and "Jy" have a low likelihood of touching the target regardless of cue, and dogs "Ch", "De" and "Lo" have a high likelihood of touching the target regardless of cue.

Figure 5.3. The log of the risk of all dogs (n=20) touching the target before the 10-second time out for each cue shown on a log scale on the y-axis with the cues on the x-axis. Standard errors shown with broken lines. Risk is high for the milk tone, showing all dogs were highly likely to touch the target after the milk tone. The lowest risk was for P9, the probe most like water. This shows dogs were unlikely to touch the target after the P9 probe cue. P5, the most ambiguous cue, also showed a low risk of dogs touching the target after this cue.

Figure 5.4. A series of graphs showing average latency (red), standard deviation (green) and log (probability of a faster than average response). In all graphs cue is on the x-axis, with probes arranged in a scale from closest to milk to closest to water. Latency in seconds is shown on the y-axis. Graph a) shows the pooled responses of dogs (n=4) categorised as optimistic (1 on the rating scale in Table 5). Characterised by standard deviation approaching the mean latency. Graph b) shows the pooled responses of dogs (n=4) categorised as moderately optimistic (2 on the rating scale). Standard deviation is lower, but the pattern of average latency is similar to that of optimistic dogs. Graph c) shows pooled responses of dogs (n=3) categorised as balanced (3 on rating scale). Characteristics are similar to those in the moderately optimistic graph. Graph d) shows pooled responses of dogs (n=3) categorised as moderately pessimistic (4 on rating scale). Average latency tends to be higher than in other graphs. Graph e) shows the pooled responses of dogs (n=4) categorised as pessimistic, typified by high initial latencies and low standard deviation. Graph f) shows the responses of a single dog characterised as optimistic. Tipping point can be seen where average latency increases by 100% or more. Standard deviation approaches mean latency and probability of faster than average response remains high for much of the graph.

Figure 6.1. The comparison of the coefficient of variation (CV) between the bodyweight groups in each of the activities that were conducted on 76 dogs. The vertical lines represent the 25th and 75th percentiles of the CV of each bodyweight group. The CV of the heavyweight dogs was significantly lower than the lightweight and middleweight dogs in Kennel Activity ($P < 0.001$) and Trotting ($P = 0.03$), and the middleweight dogs in Walking ($P < 0.001$).

Figure 6.2. Bland-Altman plots demonstrating the bias (mean difference) and variability (95% level of agreement [LOA]) of the physical activity measurements of two accelerometers (TA, Triaxial accelerometers and UA, Uniaxial accelerometers) in 76 dogs during Kennel Activity (a), Walking (b) and Trotting (c). Data with 95% LOA are marked with a dotted line and mean difference of UA and TA marked with a solid line.

Figure 7.1. A breakdown of the conceptual response landscape for training a dog to heel on leash, showing each operant training quadrant on a separate graph.

Figure 7.2. Combined conceptual response landscape for training heeling on leash in dogs using different operant training methods.

Figure 7.3. Conceptual response landscape for training heeling off leash in domestic dogs using different operant training methods.

Figure 7.4. Conceptual response landscape for training a dog to track using different operant training methods.

Figure 7.5. Conceptual response landscape for training dogs to stay (remain stationary) using different operant training methods.

Figure 7.6. Conceptual response landscapes for training two common behaviours in the domestic horse using different operant training methods.

Figure A1.1. Shelf of Apparatus V1.1. This was mounted on brackets attached to a wooden box.

Figure A1.2. Apparatus V1.2. Reservoirs were moved to boxes underneath shelf. Plastic tubing was introduced and housed in metal tubing alongside shelf. Trays moved from front to sides. Volume control was also added.

Figure A1.3. Apparatus V2.2. Reservoirs and electronics were housed behind the target on shelves hidden from view by doors. Plastic tubing ran from the pumps on the shelves behind the target, underneath the target and through the wooden base the target is attached to. Target is attached at front by hinges and tubes can be moved to dispense to one tray all the other by lifting the target to access the tubes. Trays returned to front.

Figure A2.1. Circuit diagram of Apparatus V2.x

Figure A2.2 a) and b). Finite state machine diagrams describing simple programming rules using states in circles and inputs on arrows. A) shows first training phase (TP1), and b) shows second (TP2). ITI = inter-trial interval (8s in TP1, 20s TP2). TP2A is not shown as it is the same as TP2 except that the ITI in TP2A is 30s. **Figure A2.2 c) and d).** Finite state machine diagrams describing simple programming rules using states in circles and inputs on arrows. C) shows TP3 and d) shows CBT, or cognitive bias testing phase. ITI = 20s in both phases.

Figure A3.1. Response latency graphs of dogs categorised as optimistic. Tone is shown on the x-axis, numbered from 1=milk to 11=water. Tones 2-10 were probe tones. The y-axis shows latency in seconds. The red line shows average latency, the green line shows variation, and the blue line shows the log(likelihood of a faster than average response). These dogs show high variance that approaches average latency.

Figure A3.2. Response latency graphs of dogs categorised as moderately optimistic. Tone is shown on the x-axis, numbered from 1=milk to 11=water. Tones 2-10 were probe tones. The y-axis shows latency in seconds. The red line shows average latency, the green line shows variation, and the blue line shows the log(likelihood of a faster than average response).

Figure A3.3. Response latency graphs of dogs categorised as balanced. Tone is shown on the x-axis, numbered from 1=milk to 11=water. Tones 2-10 were probe tones. The y-axis shows latency in seconds. The red line shows average latency, the green line shows variation, and the blue line shows the log(likelihood of a faster than average response).

Figure A3.4. Response latency graphs of dogs categorised as moderately pessimistic. Tone is shown on the x-axis, numbered from 1=milk to 11=water. Tones 2-10 were probe tones. The y-axis shows latency in seconds. The red line shows average latency, the green line shows variation, and the blue line shows the log(likelihood of a faster than average response).

Figure A3.5. Response latency graphs of dogs categorised as pessimistic. Tone is shown on the x-axis, numbered from 1=milk to 11=water. Tones 2-10 were probe tones. The y-axis shows latency in seconds. The red line shows average latency, the green line shows variation, and the blue line shows the log(likelihood of a faster than average response). These dogs do not show tipping points, but are characterised by high average latencies and low variance.

Figure A3.6. Response latency graphs of dogs uncategorised. Tone is shown on the x-axis, numbered from 1=milk to 11=water. Tones 2-10 were probe tones. The y-axis shows latency in seconds. The red line shows average latency, the green line shows variation, and the blue line shows the log(likelihood of a faster than average response). These dogs do not show tipping points but also do not show high average latencies that characterise pessimistic dogs.

Figure A3.7. Response latency graphs of dogs that were retested. Tone is shown on the x-axis, numbered from 1=milk to 11=water. Tones 2-10 were probe tones. The y-axis shows latency in seconds. The red line shows average latency, the green line shows variation, and the blue line shows the log(likelihood of a faster than average response). First test is shown in the left column and second test is shown in the right. Ch and Jax were retested 4 months

after the first tests, and Hu was retested 6 months after the first tests. Ch was categorised as optimistic in both cases. Jax was categorised as moderately pessimistic in first tests and optimistic in second. Hu was uncategorised in first test and categorised as optimistic in second. Increased variance in the second tests may indicate dogs are making decisions more quickly in the second tests.

List of Tables

Table 2.1. Fundamental classification of social relationships of dogs and humans. Adapted from Scott and Fuller (1965).

Table 2.2. A consideration of restraint and (giving or receiving) aversive stimuli as they arise in dog–dog, dog–human and human–dog interactions.

Table 2.3. A consideration of tactile activities (allogrooming and resting) in dog–dog, dog–human and human–dog interactions.

Table 2.4. A consideration of meeting and greeting activities among unfamiliar individuals in dog–dog, dog–human and human–dog dyads.

Table 2.5. A consideration of the ways in which dog–dog, dog–human and human–dog dyads may share resources or play with objects.

Table 2.6. A consideration of the ways in which dog–dog, dog–human and human–dog dyads greet familiar individuals and play without objects.

Table 2.7. A consideration of the ways in which dog–dog, dog–human and human–dog dyads may communicate using non-tactile mechanisms.

Table 2.8. A conceptual tabulation of the relative roles of learning theory, the value of resources and the canid intraspecific social ethogram in various common contexts.

Table 3.1. Personality traits for dogs identified by Ley et al. (2008) and possible analogues from other dog personality studies. ^a = (Ley et al. 2008); ^b = Svartberg and Forkman, 2002; ^c = (Wilsson & P. Sundgren 1997); ^d = (Draper 1995); ^e = (Cattell & Korth 1973). The possible analogue from the human “Big Five” personality traits is suggested by the authors based on common language and words used between explicit descriptions of the traits.

Table 3.2. Items from the survey that loaded high or very low on the first principal component (PC1), labelled “boldness”. The sample population was made up of 49% female and 51% male dogs. High loadings indicate items relate to boldness in dogs, where very negative loadings indicate items relate to shyness. The Behavioural Factor, as identified by Hsu and Serpell (2003), is given where items have originated from the C-BARQ questionnaire and Svartberg (Svartberg 2002; Svartberg 2005) where items originated from Svartberg’s additional play questions. Behavioural factors for items not previously used have been assigned behavioural factors by the authors.

Table 3.3 Statistical output of the fixed effects from the final linear mixed model accepted, including dog gender, reproductive status, age, breed, size and breed group. Two models are presented as high correlation between breed group and size made fitting a model including both terms problematic. Model 1 includes breed group but excludes size and is the full dataset. Model 2 excludes breed group and includes size, but is a reduced dataset, including only purebred dogs with height information in their breed standard. All terms in this linear mixed model had a significant effect on boldness. Terms included in both models have n reported first for Model 1 followed by n for Model 2. Significance is in comparison with to the reference level, which in Model 1 is companion breed, female, and neutered, and for Model 2 is giant, female, and neutered. ‘*’ Denotes a significance level of <0.05, ‘***’ a significance level of <0.005, and ‘****’ a significance level of <0.001.

Table 3.4 Boldness scores for breeds with 15 or more respondents. Boldness scores here represent random effects estimates, also called conditional modes or means, from the final

linear mixed model. In this model boldness is a component extracted from a principal components analysis (PCA) and is considered the dependent variable. It is characterised by a willingness to play and be approached and has negative loadings for avoidance behaviour and behavioural indicators of fear. Only the random effects estimate (Boldness score) has been reported because the distribution of random effects is unknown.

Table 4.1. Shows the statistical output of the fixed effects from the final linear mixed model accepted including dog sex, reproductive status, age, breed, and breed group. Significance is relative to the 'Intercept' conditions: Companion breed group, female, neutered. '*' denotes a significance level of <0.05, '**' a significance level of <0.005, and '***' a significance level of <0.001. Age in years was considered a categorical variable rather than a continuous one to show where results deviated from a linear relationship. The statistical model used was the 'lm' and 'lme' function in the statistical package R, and models were tested using the ANOVA function in R and the AIC value.

Table 5.1. A history of dogs in the study, showing their source (ADA=Assistance Dogs Australia), breed, sex (M=male, F=female) and reproductive status (N=neutered, E=entire), the protocol they were assigned to (A=milk tone lowest, B=milk tone highest), the side the milk was dispensed to, the training phase reached before the dog was excluded, and the reason for exclusion. No dogs that reached CBT (cognitive bias tests) were excluded.

Table 5.2. Frequency (Hz) of auditory tones used in training and testing. Protocol A is the reverse of Protocol B to control for possible selective attention effects that may influence response latencies.

Table 5.3. Summary of training phases and cognitive bias testing phase.

Table 5.4. A description of the mathematical model used to interpret latencies.

Table 5.5. Subjective descriptions of the behaviour of dogs during training and testing. Owners and trainers were asked to place dogs in one of the response categories described, but were allowed to place them between categories to reflect the continuous nature of the descriptions. Dogs were categorised according to their empirical variability scores (optimism rank), giving an indication of how variability scores might relate to how owners and trainers subjectively viewed the dogs' behaviour.

Table 5.6. The statistical output of the final Cox Proportional Hazards regression model for all dogs that complete the cognitive bias testing (n=20). These data describe the difference between the latency of dogs touching the target after the milk tone (reference condition) to each probe tone (CueP1-CueP9) and the water tone (Cue Water). Negative regression coefficients show a reduction in the likelihood of reaching a certain event, in this case, touching the target. Thus, the likelihood of touching the target is significantly less after probe and water tones than after milk tones. The risk of touching the target was not significantly different between trial 1 and 2, but was significantly less in trial 3 than trial 1, indicating a reduced likelihood of touching the target over successive tests. The frailty term ("Dog") refers to the dog being tested, which is treated in this model as a random effect due to repeated measures on each dog. The term "Dog" also had a significant effect on likelihood of touching the target, meaning that individuals varied significantly in their latency to touch the target.

Table 5.7. Details of dogs in the study that completed cognitive bias testing, showing source of dog, breed, sex, sessions to learning the discrimination task, and variance score computed by dividing average latency by standard deviation at each cue from the tipping point and summing them. High variance score indicates optimism. Some dogs did not have a clear tipping point, so a variance score could not be calculated. On occasions (n=4), no tipping point could be determined due to overall high latencies such that average latency could not increase by 100% and still be within the 10-second response window. These dogs were categorised pessimistic. Two dogs displayed high response rates across all cues so that average latency did not increase by 100% between two adjacent cues.

Table 5.8. Subjective ratings of dog optimism from owners (n=11) and trainers (n=11) that know the dogs in question. Data rating refers to optimism category assigned based on the dog's variance score. See Table 3 for descriptions of ratings. Ratings are an ordinal scale ranging from 1 = optimistic to 5 = pessimistic.

Table 6.1. Descriptive data on the step counts produced by the study participants (n=76). In all activities, uniaxial accelerometers (UA) consistently recorded higher step counts than triaxial accelerometers (TA).

Table 6.2. Spearman correlation coefficients of the step counts produced by triaxial accelerometers and uniaxial accelerometers across three types of activity. A significant correlation was only found in Kennel Activity.

Table 6.3. Spearman correlation coefficients of the step counts produced by triaxial accelerometers and uniaxial accelerometers across three categories of bodyweight. UA and TA were significantly correlated in all bodyweight groups, with the highest correlation found in the heavyweight group.

Table 7.1. Summary of the conditions considered in the formation of the response landscapes. Each target behaviour is named and described and the forms of positive reinforcement (PR), negative reinforcement (NR), positive punishment (PP) and negative punishment (NP) considered common and easily accessible are listed.

Abbreviations

| | |
|-------------|-------------------------------|
| <i>NR</i> | Negative Reinforcement |
| <i>PR</i> | Positive Reinforcement |
| <i>PP</i> | Positive Punishment |
| <i>NP</i> | Negative Punishment |
| <i>PCA</i> | Principal Components Analysis |
| <i>TP1</i> | Training Phase 1 |
| <i>TP2</i> | Training Phase 2 |
| <i>TP2A</i> | Training Phase 2A |
| <i>TP3</i> | Training Phase 3 |
| <i>CBT</i> | Cognitive Bias Test |
| <i>CV</i> | Coefficient of variation |
| <i>LOA</i> | Limits of agreement |
| <i>PA</i> | Physical activity |
| <i>TA</i> | Triaxial accelerometer |
| <i>UA</i> | Uniaxial accelerometer |

List of publications included in this work

Published Papers

McGreevy, P.D., Starling, M, Branson, N.J., Cobb, M.L., Calnon, D. (2012) An overview of the dog–human dyad and ethograms within it. *Journal of Veterinary Behavior: clinical applications and research*, 7(2), 103-117.

Starling, M.J., Branson, N.J., Thomson, P.C., McGreevy, P.D. (2013) “Boldness” in the domestic dog differs among breeds and breed groups. *Behavioural Processes*, 2013, 97, 53-62.

Starling, M.J., Branson, N.J., Thomson, P.C., McGreevy, P.D. (In press) Age, sex and reproductive status affect boldness in dogs. *Veterinary Journal*, 2013. Available online 15th June 2013.

Starling, M.J., Branson, N.J., Cody, D., McGreevy, P.D (2013) Conceptualising the impact of arousal and affective state on training outcomes of operant conditioning. *Animals*, 3, 300-317

Submitted papers currently under review

Starling, M.J., Branson, N.J., Cody, D., Starling, T.R., McGreevy, P.D Canine Sense and Sensibility: Tipping points and response latency variability as an optimism index in canine judgement bias assessments. *PLoS One*.

Cheung, K.W., Starling, M.J., McGreevy, P.D. A comparison of uniaxial and triaxial accelerometers for the assessment of physical activity in dogs. *Journal of Veterinary Behavior: Clinical Applications and Research*.

McGreevy, P.D., Henshall, C., Starling, M., McLean A, Boakes, R. The importance of safety signals in animal handling and training. *Journal of Veterinary Behavior: Clinical Applications and Research*.

Table of Contents

| | |
|---|------------|
| Declaration | i |
| Acknowledgements..... | ii |
| A note on style..... | xi |
| List of Figures..... | xii |
| List of Tables | xvi |
| Abbreviations..... | xix |
| List of publications included in this work..... | xx |
| 1.0 Introduction | 1 |
| 1.1 The Dog-Human Dyad..... | 2 |
| 1.3 Personality | 4 |
| 1.3.1 “Big Five” Personality Dimensions | 7 |
| 1.3.2 Super-traits..... | 8 |
| 1.3.3. Breeds | 10 |
| 1.3.4. Age, sex and reproductive status..... | 12 |
| 1.3.5. Coping Styles..... | 13 |
| 1.3.6. Coping and personality in dogs..... | 16 |
| 1.4. Welfare | 17 |
| 1.4.1. Cognitive Bias..... | 18 |
| 1.4.2. Validating Indicators of Affective State | 21 |
| 1.5. Arousal..... | 24 |
| 1.6. Safety Signals..... | 27 |
| 2 An overview of the dog–human dyad and ethograms within it..... | 30 |
| 3 "Boldness" in domestic dogs differs among breeds and breed groups..... | 61 |
| 4 Age, sex and reproductive status affect boldness in dogs..... | 90 |
| 5 Canine Sense and Sensibility: Tipping points and response latency variability as an optimism index in canine judgement bias assessments. | 105 |
| 6 A comparison of uniaxial and triaxial accelerometers for the assessment of physical activity in dogs..... | 132 |
| 7 Conceptualising the impact of arousal and affective state on training outcomes of operant conditioning..... | 150 |
| 8 The importance of safety signals in animal handling and training | 175 |
| 9.0. Discussion and Future Directions..... | 190 |
| 9.1. Judgement bias..... | 190 |
| 9.1.1. Apparatus | 190 |
| 9.1.2. Repeated Testing..... | 194 |
| 9.1.3. Interpretations of judgement bias data..... | 194 |
| 9.1.4. Development of additional indicators..... | 200 |
| 9.1.5. A note about terminology..... | 202 |
| 9.2. Dog personality research | 202 |
| 9.3. The dog-human dyad | 203 |
| Conclusions..... | 207 |

| | |
|---|-------------|
| References..... | 209 |
| Appendix 1 Diagrams of Apparatus Versions | I |
| Appendix 2 Further information on apparatus components and programming | III |
| Appendix 3 Response Latency Graphs..... | VIII |
| Appendix 4 Copy of survey referred to in Chapters 3 and 4 | XIII |

1.0 Introduction

An understanding of behavioural variability in animals improves our ability to predict how individuals are likely to behave (Svartberg 2003). It is well recognised that the domestic dog (*Canis lupus familiaris*) has the potential to gravely injure humans and other animals. Being able to reliably predict behaviour may go a large way towards reducing the risks for humans living alongside such an animal. Dog bite statistics are fragmented and incomplete in Australia, but it is estimated that over 100 000 Australians every year suffer from dog bites with varying degrees of injury severity resulting (Ozanne-Smith et al. 1998). Data from one Australian state indicate that over 60% of dog bites occur in or around the home and children under 5 years are at the greatest risk (Ashby 2001). The authors cite the behaviour of children around dogs at play and feeding times and an increased likelihood of injury to the head or face, probably due to relative height, as risk factors for dog bite in children. Behaviour prediction may help to match dogs to suitable homes. Every year, a significant percentage of the domestic dog population are destroyed because humans find their behaviour unacceptable (McGreevy & Bennett 2010). The ability to accurately predict dog behaviour in a variety of scenarios may help to address potential behavioural problems early on or match dogs with owners that have the skills required to train and manage them. Some dog personalities may be more difficult for inexperienced companion-dog owners to manage than others. Identifying such dogs early may help prevent dogs from being euthanised or surrendered due to behavioural problems owners are unable or unwilling to address. Finally, understanding and being able to predict variability in dog behaviour may aid in selecting dogs for breeding and training programs. Dogs work in several capacities, from search and rescue, odour detection for security and conservation, aiding police and military operations, hunting, livestock herding, and as assistance dogs for humans with disabilities. Breeding and selecting dogs specifically for these jobs has been of interest for some decades. There is ongoing interest in how to select dogs for various working dog

industries. Even when dogs are specifically bred for a job, failure rate in training is typically as high as 50-70% (Duffy & Serpell 2012).

Behavioural variability in dogs is the result of a complex mixture of genetic, environmental and learning influences. Personality, arousal level, emotional state, and past learning history may all play roles in the behaviours displayed by an individual dog at a given moment. It is also important not to overlook the possible effects of ethologically appropriate behaviours that dogs still readily display in spite of many thousands of years of artificial selection. For example, greetings, threat displays, and stop signals are ritualised in dogs and well preserved across all dog breeds, as evidenced by broad ethograms and books describing general dog behaviour and signals (e.g. Aloff 2005; Abrantes 1997). This literature review will explore possible influences on behavioural variability in dogs and address the validity of factors currently thought to have an effect.

1.1 The Dog-Human Dyad

The dog-human dyad refers to the relationship between dogs and humans. In the Westernised world dogs at the most basic level are considered human property, which is reflected in legislation. Dogs in the western world have increasingly become valued as companion animals, supporting a pet industry worth \$3.6 billion in Australia in 2009, a 31% increase since 2005 (Australian Companion Animal Council Inc. 2010). This industry spans an enormous range of services and products that indicates the breadth and variability of the dog-human relationship, from gourmet pet food, toys, clothes, doggy daycare, dog walkers, professional trainers and behaviourists, training tools, animal chiropractors, animal communicators, holistic vets, and canine specific medication.

The dog-human relationship in the Westernised world may be one of harmony and mutualism, benefitting both dog (Kotrschal et al. 2009) and human (Barker & Wolen 2008). It may also at its worst be punctuated with animal abuse (see Ascione 2008 for review), human injury or even death through dog attacks, and the euthanasia of unwanted and abandoned dogs (McGreevy & Bennett 2010). Miscommunication between dogs and humans can lead to disaster for one or

both members of the dyad, and may also lead to nuisance or menacing behaviour that has a negative impact on the wellbeing of the broader community such as barking or inappropriate chasing (Voith 2009). A better understanding of canine social behaviour and how dogs may use it to try to communicate with humans is likely to improve the safety and wellbeing of both dogs and humans when the two species mix. It follows that studying how dogs and humans interact may allow information to be collected that improves our ability to predict dog behaviour. This may be particularly relevant in training scenarios where humans are often attempting to discourage aspects of natural canine behaviour and encourage behaviour that the dog may not be highly motivated to perform.

Domestic dogs have a long association with humans that depends largely on our ability to train them. Even dogs selectively bred over many generations to perform a specific task that benefits humans, such as herding or guarding livestock, typically receive at least some rudimentary training (Coppens & de Boer 2010). Training ranges from conditioning simple behaviours that optimise sharing a living space with dogs to highly specific and complex behavioural sequences that capitalise on the abilities of dogs, such as speed, agility and a keen sense of smell. Current approaches for training animals are generally anchored in operant conditioning (McGreevy & Boakes 2007). The science behind operant conditioning is detailed, sound, and very useful, but this model operates at a simple level of associations between cause and effect. It does not incorporate some of the more esoteric factors underlying the complexity of behaviour such as motivation, personality, arousal or context specificity. For example, in dogs, it may fail to fully explain why one dog may perform differently with one trainer compared to another, despite both trainers using the same operant techniques (e.g. McGreevy et al. 2012). Perhaps it is this perceived failure of operant conditioning to explain such commonly observed phenomena that increases the public appeal of so-called dog whispering techniques that are presented as ways of obtaining desired behaviour ostensibly by communicating with the dog in their own language (e.g. Millan 2006). Dog whisperers may not have been formally trained in learning theory, just as the general dog-owning public has not, and their success in training dogs may have alternative

explanations than that they are communicating directly with a dog in a way the dog naturally understands.

This project aims to explore the variability in dog behaviour we observe and the possible causal factors behind them. The starting point for this exploration is to evaluate what individual dogs have in common with each other and with humans. The paper presented in Chapter 2 contains an extensive literature review of social order and the history of social-domination belief systems as a precursor to a further review of the literature on canine social behaviour and social learning. This sets the stage for an examination of the canine-human ethogram, which shows the limitations of human communication with dogs via human analogues of canine social behaviour and a discussion of the place of learning theory in evaluating dog-human interactions.

1.3 Personality

Personality studies in animals should be approached using a single framework so that ideally they can be compared with each other in the future (Gosling 2001). The inconsistencies found in the dog personality literature alone (see Fratkin et al. 2013 for review) highlight the need for a unified approach, or at least agreement on some commonly used constructs. It is common for personality studies in animals to use different terminology, making it very difficult to compare personality studies in animals to identify what broad personality traits exist across species and how this affects the behaviour expressed (Gosling 2001). There is no one definition even in human personality research that would encompass all the interpretations of the term (Gosling 2001). Gosling (2001) recommends that a broad definition be adopted for this reason, such as that given by John et al. (2008) who described personality as being a characteristic of individuals and accounting for consistent patterns of feeling, thinking and behaving. However, this may be a difficult definition to use in animal studies where there can be no self-reporting. This may explain why personality in animal studies is commonly defined by observable behaviours that can be measured in standardised ways (Dingemanse & Wolf 2010).

Temperament in human personality research is defined by some as inherited

tendencies that appear early and serve as a foundation for personality (Goldsmith et al. 1987), but in the animal personality literature it is sometimes used interchangeably with personality (Gosling 2001).

Studies of animal personality generally rely heavily on the concept of personality traits. Trait psychology is concerned with patterns in thoughts, feelings, emotions and behaviours (Sinn et al. 2010b; McCrae et al. 2000). Although it fell out of favour for several decades in human psychology, it has remained at the forefront of animal personality studies, perhaps because it suits the focus of animal studies on observable, measurable behaviours and the inability of animals to self-report. Many traits used in dog personality research are identified through surveys of dog owners. The validity of such studies may be difficult to determine. The internal consistency of survey data can be examined through inter-rater reliability testing, where more than one person fills out the same survey and the responses are tested for statistical reliability. This offers a measure of how consistently individual observers describe the same individual (Sinn et al. 2010b). Previous studies suggest inter-rater agreement varies with the trait in question, typically being high in dogs for most traits, but low in others (Ley et al. 2009; Sinn et al. 2010b; Rooney et al. 2007) which is a poorly understood phenomenon. Some broad possible explanations for the discrepancies in inter-rater agreement have been raised, such as differing levels of acquaintance with the animals, the level of communication between raters about the animals, the history of exposure to the species for each rater, and whether some animals or traits are inherently harder to judge than others (see Gosling 2001 for further discussion). Despite these potential issues having been identified, studies tend to be designed to discover whether there is inter-rater agreement rather than identifying reasons why inter-rater agreement may differ between traits, so the discrepancies remain a mystery. Similar problems also manifest in test-retest reliability procedures that test the stability of traits and whether their measurement is repeatable over time. High test-retest reliability has been reported for traits related to sociability, extraversion, neuroticism and curiosity over short time-frames (up to 6 months) (Svartberg 2005; Ley et al. 2009), but test-retest reliability was lower in traits that were retested again 1-2

years later (Svartberg 2005). Discrepancies also exist between studies. For example, aggression was reported to have high test-retest reliability over 6 months in one study (Netto and Planta 1997), but low in another over the same period (Goddard and Beilharz 1986). These inconsistencies were also shown in a recent meta-analysis of dog personality studies, although the study nevertheless concluded there was moderate consistency in personality traits reported in the dog literature, regardless of differences in methodology detail (Fratkin et al. 2013). Discrepancies in results may be attributed to one or more of a variety of conditions, such as an absence of standardisation in methodology, subjectivity of interpretation of behavioural observations, or a lack of validation of both behavioural observations and data collected by survey.

Whether the results of surveys used to collect information about dog personality traits truly represent data about dog personality traits, or are more representative of the respondent's opinions about dog personality traits may be best explored through the addition of behavioural observations. Similarly, within-study bias can be minimised by comparing survey responses with validated behavioural observations. Unfortunately, there is also a distinct lack of validated behavioural observations in dog personality research. There are personality assessment tools that have been used extensively and are based on scoring dog behavioural responses to a suite of stimuli. However, this approach comes with its own set of problems, as behavioural observations are typically dependent on subjective measures and there is no internal validation that would at least show that scoring is consistent between scorers. For example, the Swedish Working Dog Club's "Dog Mentality Assessment" has been used in several studies and appears to produce repeatable results within the timeframe of 3-4 months (Svartberg et al. 2005), but the tests are scored by one person alone and some of the stimuli introduced during the test are human and therefore can communicate more to the dogs being tested than simply the appearance of a stimulus. Variables such as environmental conditions that may influence dog behaviour are not taken into account.

The field may benefit from a more mathematical approach to defining personality, perhaps based on probabilities of performing various behaviours and numerical measurements such as latencies, extinction curves, and standardising the number of trials to establish repeatability for validation purposes. In this way a framework for understanding and explaining personality may be built from validated data rather than fitting the data to an already established framework. It is certainly logical to attempt to build a framework for dog personality on frameworks already established for human personality (Gosling & John 1999), but a mathematical approach to animal personality would avoid many of the problems associated with human bias, subjectivity, and emotional interpretations.

The problems with the field of dog personality research that have been outlined here do not exclude scientists from making significant inroads into understanding animal personality and how it may influence behavioural variability. The following sub-sections will address some of the key areas of research in the field and how they have contributed to our understanding of behavioural variability.

1.3.1 “Big Five” Personality Dimensions

A comparatively unified approach to personality has been achieved in human personality research with the acceptance of the “Big Five” personality traits. The Big Five personality traits are listed as Extraversion, Agreeableness, Conscientiousness, Neuroticism (or Emotional Stability), and Culture (Goldberg 1990). It has been suggested that these personality types are comparable to some major personality traits in animals (Draper 1995; Gosling & John 1999). Aggressiveness, Boldness, and Fearfulness have been suggested for several different animal species (Wilson et al. 1994; Gosling et al. 2003; Boissy et al. 2007), and may relate to the shyness-boldness continuum as recorded in a wide range of species from fish (Harcourt et al. 2010), to humans (Wilson et al. 1994).

Some of the traits identified in dog personality studies so far may be analogous to one another but labelled differently, for example, “training focus” (Ley et al. 2008) and “trainability-openness” (Draper 1995). There is broad variation in how many traits are identified in dog personality studies. Although some analogues may exist between studies, other personality dimensions have been identified but they do not seem to correspond closely to personality dimensions discussed in other canine studies. These include Chase-proneness (Svartberg & Forkman 2002), Aggressiveness, Aggressive Excitation, Aggression-disagreeableness (Cattell & Korth 1973; Draper 1995; Svartberg & Forkman 2002), Exuberance, Timidity, Calmness, and Aloofness, (Cattell & Korth 1973). Their lack of support from other studies in the literature may or may not be meaningful. Data reduction methods such as factor analysis and principal components analysis have been used in most of the studies discussed here to identify major personality dimensions. Such methods may offer a means to assess statistically how many personality traits may be captured with one method of inquiry and what those traits might mean practically in relation to the narrow field of data collected, but they still depend on subjective interpretations. The studies that identify dimensions not picked up by other studies differ only in the data that were collected and later subjected to data reduction. This problem plagues the field, with very little overlap in the data collected between studies. It is compelling to see multiple reports on what seems likely to be the one personality trait. The agreement in studies adds weight to the adoption of these traits. However, identification of personality traits in dogs may at this point be a largely subjective affair, even in academic studies. If a trait has only been reported once, this does not necessarily mean that it is less likely to exist in the dog population.

1.3.2 Super-traits

“Super-trait” is a term that has been used in human and animal personality literature to identify higher-order personality traits that represent major axes of variation (Krueger et al. 2001; Svartberg 2002; Zuckerman 1994; Svartberg 2005). One such axis referred to in the dog personality literature is the shy-bold

axis (Svartberg & Forkman 2002; Svartberg 2002). This super-trait has been the subject of a number of studies on dog personality. It is assumed to be stable, although support for its stability is subject to the same problems with validity as already discussed. Consistent re-test behavioural results over a short period (2-3 months) (Svartberg & Forkman 2002) and consistent survey results over a longer period (1-2 years) (Svartberg 2005) are compelling, but do not take into account how stable shyness or boldness is over a longer period. Also, they represent relatively isolated studies in the field. Traits related to boldness include curiosity, fearlessness, playfulness, distance playfulness, chase-proneness and sociability (Svartberg & Forkman 2002). These traits were grouped into broader personality factors under the influence of the shy-bold axis, listed as “playfulness”, “curiosity/fearlessness”, and “sociability” (Svartberg 2005). Later work suggested that survey responses identified five correlations with boldness, including positive correlations with “human-directed play interest”, “stranger-directed interest”, and “trainability”, and negative correlations with “stranger-directed fear” and “non-social fear” (Svartberg 2005).

In a practical sense, boldness may have an impact on how dogs behave and respond to training. Svartberg and Forkman (2002) revealed that dogs that performed well in working dog trials tended to rate high on personality factors indicating high boldness rating on the shy-bold continuum. The personality factors used were “Playfulness”, “Curiosity/Fearlessness”, “Chase-proneness”, “Sociability”, and “Aggressiveness”, with all but Aggressiveness coming under the over-arching shy-bold continuum (Svartberg & Forkman 2002). Bold dogs rated highly on all tasks, suggesting that bold dogs are in general more successful in training endeavours (Svartberg 2002). Wilsson and Sundgren (1997) used the same behavioural tests from the Swedish DMA as Svartberg (Svartberg 2005; Svartberg & Forkman 2002), and found that high scores in sharpness and defence and prey drive predicted successful training for a German Shepherd Dog in police work, whereas Labrador Retrievers successfully trained as guide dogs scored higher in factors labelled cooperation. Labrador Retrievers exhibiting fear or anxiety are predicted to be unsuitable for training as guide dogs (Goddard &

Beilharz 1986), and German Shepherd Dogs that perform well on retrievals at a young age and show high levels of aggression at 9 months are predicted to be efficient police dogs (Slabbert & Odendaal 1999). These three authors found that predictions about future behaviour became more reliable with age (Slabbert & Odendaal 1999; Goddard & Beilharz 1986).

1.3.3. Breeds

One of the logistic challenges of dog personality research is investigating the effects of breed on behaviour. Dog experts seem to believe they exist (e.g. Bradshaw et al. 1996), but despite commercially available dog genotyping services, it remains unclear whether consistent behavioural patterns observed within breeds reflect genotype. Some studies present evidence that suggests dog behaviour differs between breeds, which may be related to personality traits (Svartberg 2006a; Turcsán et al. 2011; Bradshaw et al. 1996), but the rigour of these links is arguable given the lack of standardisation of methodology used in personality literature described above. Historically, kennel clubs (e.g. American Kennel Club etc.) have clustered breeds according to similarities in morphology and anecdotal information about the development of breeds for specific purposes (Turcsán et al. 2011). Problems have been identified with the objectivity of this approach. First, the origins of breeds and their development are rarely well documented, are often steeped in oral tradition and usually lack verifiable references. Second, breed folklore may encourage people to adopt stereotypic views of particular breeds, with owners showing a confirmation bias as they report the behaviours they expect to see in their dogs, which in turn may perpetuate the stereotypic view (Turcsán et al. 2011). In addition, different kennel clubs adopt different groups. The Australian National Kennel Club (ANKC), for example, has seven groups (Toys, Terriers, Gundogs, Hounds, Working Dogs, Utility and Non Sporting) whereas the AKC has eight (Sporting, Hound, Working, Terrier, Toy, Non-sporting, Herding and Miscellaneous). Groups such as “utility” may simply reflect a catch-pool for breeds that do not fit well into better-defined groups. Further confounding the problem is the shift from breeding dogs for a specific purpose to breeding dogs primarily as

companions (McGreevy & Nicholas 1999) and show dogs (Svartberg 2006a). Attempts to find similarities within breed groups have met with mixed success and results suggest that kennel club breed groups do not necessarily cluster breed types with similar behaviour or genotype (Svartberg 2006a; Turcsán et al. 2011; Bradshaw et al. 1996). Nevertheless, there may be more to breed groups than has been considered thus far in the scientific literature. The diversity in dog behaviour within and among breeds and breed groups might suggest that traditional kennel club groups are simply not categorised at a fine enough level of detail to produce consistent results at group level. For example, within the herding breeds, there are sheep-herding and cattle-herding breeds (Morris 2001). Within the gundog group, there are flushing breeds, pointing breeds, and retrieving breeds (Schmutz & Schmutz 1998). More recently, scientists have begun to assess dog breeds at the level of genotype, rather than phenotype, including studies examining the genetic relationships among dog breeds (e.g. Vilà et al. 1997; Lindblad-Toh et al. 2005). Breed accounts for over 27% of the genetic variability in the modern dog (Sutter & Ostrander 2004). Breeds are usually genetically diverse, probably because most breeds are modern and have been derived from a large gene pool (Vilà et al. 1997), and sufficiently genetically different that breed can be identified through DNA (Koskinen 2003). Genetic relationships between breeds have only recently been explored in detail, and sometimes follow kennel club breed groups and sometimes do not. For example, herding breeds generally do appear to belong to the one genetic group, but some sighthound breeds are more closely related to ancient spitz breeds than other sighthound breeds, and neither are closely related to scenthounds, which are often in the same kennel club group as sighthounds (vonHoldt et al. 2010; Parker et al. 2007). Furthermore, it has been shown that there is genetic stratification within breeds so that a single breed should not necessarily be considered a single population (Chang et al. 2009). The main problem with grouping dogs based on genetic relatedness in personality or behavioural research is that some breeds have not been assessed this way yet. Parker et al. (2007) included 132 breeds divided into 5 major groups, whereas von Holdt et al. (2010) included 85 breeds and assigned them to clusters of close relatedness. Other datasets, particularly those from Australia where some common breeds

such as the Kelpie and Australian cattle dog have not been analysed, will contain a significant proportion of breeds or breed mixes that cannot be assigned to a genetic grouping.

1.3.4. Age, sex and reproductive status

The effect of sex and reproductive status on behavioural variability has emerged rarely in dog personality literature. Male neutered companion dogs are believed to be more trainable than male entire dogs as determined the CBARQ survey tool (Serpell & Hsu 2005), and male dogs have been shown with behavioural observations to be bolder than female dogs, although this association fades in high performing sport dogs (Svartberg & Forkman 2002). Further investigation of the dog literature proved this to be a rare line of inquiry in general. One study suggests that neutered dogs behave more aggressively, and are more excitable and anxious and less trainable than entire male and female dogs (Farhoody & Zink 2010), which was also measured using CBARQ. Svartberg found that boldness as determined from behavioural tests correlated most positively with trainability, stranger-directed interest, and human-directed play interest, and more negatively with stranger-directed fear and non-social fear (Svartberg 2005). As such, the findings of Farhoody and Zink (2010) suggest that neutered dogs are less bold than entire dogs. Further investigation of this aspect of dog personality may be enlightening, especially considering broadscale encouragement of pet dog neutering.

The effect of dog age on personality expression is another topic that has received surprisingly little attention in the dog personality literature. Surprising because it is known dog behaviour may change with age. For example, aging dogs are known to approach cognitive tasks in different ways (Salvin et al. 2011) and may lose behavioural inhibition or reduced sensory capacity as they age (Salvin et al. 2012). These physiological changes may have an effect on personality traits. It is unknown when personality in dogs may be considered stable, but previous studies suggest behaviour in dogs under 9 months of age is not strongly indicative of adult dog behaviour in most cases (Goddard & Beilharz 1986). A

recent meta-analysis of dog personality consistency showed moderate consistency in puppy personality traits, but consistency differed between personality traits, with some such as aggression and submissiveness being more consistent than others (Fratkin et al. 2013). Few studies have investigated whether personality in dogs may change as they age beyond early adulthood (Jones & Gosling 2005). The meta-analysis on personality consistency showed that personality in dogs was more consistent when there were short intervals (> 10 weeks) between measures than large intervals (> 24 weeks), but there is little information available beyond 18 months of age and none beyond 5 years of age (Fratkin et al. 2013). The paucity of studies on behavioural change that may reflect changes in personality over time in dogs should be addressed.

1.3.5. Coping Styles

It is important to include coping styles in a review of personality and behavioural variability in dogs because they describe a coherent set of behavioural and physiological responses to stress that are consistent over time and characteristic of a certain group of individuals (Koolhaas et al. 1999). Coping styles have been explored primarily in the laboratory rodent literature, but have drifted into other taxa such as pigs, birds, fish, cattle, and Rhesus monkeys (Koolhaas et al. 1999), and has more recently been proposed to explain some behavioural variability observed in dogs (Blackwell et al. 2010; Horváth et al. 2007; Sheppard & Mills 2002). Coping styles are thought to fall into one of two categories: proactive or reactive. Both proactive and reactive coping styles are adaptive, and the difference in responses is only detectable where the animal is given the choice between two equally adaptive strategies (Koolhaas et al. 2010). The assumption has been made that proactive and reactive coping styles and shy and bold personality traits are essentially the same thing, simply referring to stable, alternative response patterns to challenges (Coppens & de Boer 2010) despite their descriptions being relevant to different species and different behaviours. The literature has been handled separately here to reflect the incomplete fusion of the concepts involved into one construct.

The behavioural characteristics of proactive and reactive coping individuals have been identified through a variety of stress tests and learning tasks. Proactive mice have a general active behavioural strategy focused on manipulating circumstances or removing themselves from the situation (Benus et al. 1991). Rodents with a reactive coping style are considered to have a more passive behavioural strategy, focused on adjusting themselves to the situation and accepting it (Benus et al. 1991). Proactive individuals show active behaviours in aversive situations, such as active avoidance when faced with controllable shocks (Benus et al. 1991), and active exploration of the environment during trials involving uncontrollable shocks (Benus et al. 1989), whereas reactive animals show more passive withdrawal (Fokkema & Koolhaas 1985) and more and longer bouts of immobility than proactively coping conspecifics (Benus et al. 1989). Proactive rodents respond to a probe in their home cage that delivers a small electric shock by actively burying the probe with bedding material, whereas reactive rodents respond with periods of immobility (Koolhaas et al. 1999). Proactive rodents performed better at actively avoiding an electric shock in a shuttle avoidance procedure than reactive rodents (Benus et al. 1991). Proactive piglets show a similar pattern, being faster to approach novel items than reactive piglets, but spending less time exploring them (Hessing 1994). This aligns with research showing that birds that explore new areas first also spend less time exploring them than the birds that approach a new area more slowly (Verbeek et al. 1994). Both strategies are thought to have their own benefits. For example, fast explorers may find new resources first, but may also be more exposed to predation than their more cautious counterparts (e.g. Jones & Godin 2009) and be less responsive to signals of threat (Exnerová et al. 2010).

When it comes to reacting to change, proactive animals appear to be more internally driven by routine and do not attend to changes in the environment such as a maze being rotated 90 degrees or a piece of adhesive tape on the floor, whereas such events result in reactive animals exploring extensively (Benus et al. 1990). Proactive mice take twice as long to adjust to a changed light-dark cycle as reactive mice and, in reversal learning, make more errors than the reactive coping individuals and for longer (Benus et al. 1990). Proactively coping

hamsters have also been shown to prefer a small but immediate reward over a large but delayed reward, which indicates impulsivity, whereas reactive hamsters prefer large, delayed rewards (Cervantes & Delville 2007). The proactive animal appears to behave from prior experience in feed-forward way, which may be fast, but also inaccurate (Coppens & de Boer 2010).

Rats that show proactive coping by defensively burying electric probes in their home cage also show high plasma noradrenaline and corticosterone concentrations (De Boer et al. 1990; Korte et al. 1996). In the most extremely aggressive wild type rats, the highest levels of defensive burying were observed and also a larger catecholaminergic reactivity to electrified prod exposure and after social defeat (Sgoifo et al. 1996). A catecholaminergic reaction includes both elevated plasma noradrenaline and adrenaline concentrations. More competitive, proactive male rats react to social defeat with higher blood pressure and catecholamine concentrations and also have higher baseline concentrations of noradrenaline (Fokkema & Koolhaas 1985). Proactive rodents show low hypothalamic-pituitary-adrenal (HPA-axis) reactivity, which is characterised by low plasma corticosterone concentrations, but high sympathetic reactivity – characterised by high concentrations of catecholamines – in response to stressful stimulation (Koolhaas et al. 1999). Aggressive rodents also show reduced circadian peak plasma corticosterone concentrations and high baseline testosterone concentrations compared to non-aggressive rodents (Korte et al. 1996; de Ruiter et al. 1992). High-resistant pigs perform poorly in reversal learning of a T-maze (Bolhuis et al. 2004), and have a lower HPA axis reactivity, just like proactive coping rodents (Ruis et al. 2000), and chickens most prone to feather pecking (Korte et al. 1997; Korte et al. 1999). The immobility seen in reactive coping rodents is associated with low plasma noradrenaline and high corticosterone (De Boer et al. 1990; Korte et al. 1996). Reactive coping rodents show higher HPA axis reactivity and higher parasympathetic reactivity than proactive coping rodents (Koolhaas et al. 1999). Low-resistant pigs also show high HPA axis reactivity and high parasympathetic reactivity, just like the reactive coping rodents (Ruis et al. 2000). The same pattern was found in

chickens with a low frequency of feather pecking (Korte et al. 1997; Korte et al. 1999).

1.3.6. Coping and personality in dogs

Boldness and shyness or proactive and reactive coping styles may be a measure of behavioural syndromes only, as neither account for the emotional intensity of the behaviour (Coppens & de Boer 2010). Some authors question the accuracy of assigning a large number of behavioural tendencies to just one factor such as the shy-bold axis. Sheppard and Mills (2002) argue that assigning behavioural tendencies to this single axis is not consistent with the proposed biological basis of those behaviours, and instead propose two scales that they label positive activation and negative activation. The positive-activation scale is characterised by energised, excitable and persistent behaviour associated with reinforcing experiences, whereas the negative-activation scale encompasses more inactive behaviours and avoidance behaviours associated with negative experiences (Sheppard & Mills 2002). In contrast, the shy-bold continuum and coping styles do not consider emotional states and Sheppard and Mills (2002) suggest that the shy-bold axis probably consists of both positive and negative activation elements. A third coping style – ambivalence – has been described only in dogs, and is characterised by high physical activity and higher concentrations of cortisol in response to stressors than those found in proactive or reactive animals (Horváth et al. 2007). Blackwell et al. (2010) conclude that, in shelter dogs, a proactive coping style is characterised by high HPA-axis activation and heightened ability to rapidly learn a new task, compared to a reactive coping style characterised by fearful behaviour and an impaired ability to learn a new task. Dogs were differentially affected by being housed in a shelter environment, depending on their proposed coping style, with behavioural signs of stress such as inactivity and avoidance of interactions being associated with an impaired ability to learn a simple shaping task, possibly reflecting a reactive coping style (Blackwell et al. 2010). Dogs with higher HPA-axis activation displayed an enhanced ability to learn the same task, possibly indicating a more proactive coping style (Blackwell et al. 2010). However, one of the factors confounding

these conclusions is lack of a clear association between behavioural stress indicators and HPA-axis activation (Beerda et al. 2000; Beerda et al. 1997).

1.4. Welfare

The discussion in the previous sections on coping styles and their possible effects on personality raises the possibility that personality may also play a role in animal welfare. For example, the physiological differences in proactive and reactive coping styles point at differences in the way individual animals may experience aversive events or chronic, mildly stressful conditions, such as being housed in a shelter environment. This has implications for how we should assess animal welfare both at the individual and at the population level, and raises questions about whether welfare measures benefit the individuals that need them most.

Animal welfare science focuses on the assessment and the potential optimisation of the quality of life of animals. It is now widely accepted that animals experience pain and suffering (Boissy et al. 2007), so it follows that they should also be able to experience pleasure, and indeed, when they obtain certain resources they often display behaviour reminiscent of pleasure in humans (Boissy et al. 2007). Animal welfare initiatives have traditionally focused on identifying negative states tied to stressors such as those causing pain, fear, anxiety and frustration (Boissy et al. 2007; Duncan 2006), as it was assumed that they reflect poor welfare and that therefore good welfare would be an absence of these states (Duncan 2006). However, there are problems with this approach. For example, negative states are adaptive and consequences of a stress response may be protective (Korte et al. 2007). Assessments of animal welfare should not focus purely on avoiding pain and suffering, but should also provide positive, pleasurable activities and resources (Seligman & Csikszentmihalyi 2000). It is therefore of growing importance to identify accurate indicators of positive and negative affective state in animals.

Identifying accurate indicators of positive and negative affective state in animals is deceptively difficult, chiefly because it is difficult to identify a universally positive event and a universally negative event in order to distinguish between positive and negative emotional states for any animal species (Boissy et al. 2007). It can be assumed that pain at least is a universally aversive event, although it is difficult to determine differences in pain perception (see Viñuela-Fernández et al. 2007 for review). Separation from group members is known to be aversive to gregarious animals (Baldock & Sibly 1990; Sandem & Braastad 2005), but some individuals may experience it more keenly than others. Some activities such as play and feeding are presumed to produce a positive emotional state in mammals (Burgdorf & Panksepp 2006), but are susceptible to complications such as motivation (e.g. Barnard & Brown 1987). It has been shown that animals housed in enriched environments (e.g. with natural perches for birds or activity wheels for rodents) show signs of being in a more positive affective state than animals in standard, unenriched laboratory housing (Young 2003).

Some recent attempts have been made to measure positive affective state in different mammalian species using simple behavioural and physiological indicators of affective state such as changes in ear orientation, heart rate, and body surface humidity (Reefmann et al. 2009; Schmied et al. 2008). However, it should be noted behavioural indicators may reflect attempts to communicate an affective state to conspecifics rather than faithfully indicate affective state itself (Kraut & Johnston 1979; Marler & Evans 1996; Zimmerman et al. 2003). Behaviours chosen as indicators of affective state should occur consistently in a variety of contexts that are expected to be positive or negative, but should not occur in both positive and negative contexts (Paul et al. 2005).

1.4.1. Cognitive Bias

In recent years, the animal welfare research field has been titillated by a new method that may offer a means to measure objectively both positive and negative affective states simultaneously in any animal without relying heavily on

invasively procured physiological measures or subjective scoring of behavioural indicators. Cognitive bias is a term used in the human literature to describe the effects of emotional state on information processing and decision-making (Hinde 1985; see Paul et al. 2005 for review). Cognitive biases have been demonstrated in tasks involving attention, perception, memory, expectations and risk assessment (Mathews and MacLeod 1994; Mineka, Watson et al. 1998; Schwarz 2000). Optimism in humans is an example of expectation bias. Optimism is characterised by higher than usual expectancies of positive outcomes (Scheier & Carver 1985) and there is a large body of literature on its benefits for coping with stress and feelings of psychological well-being (see Carver et al. 2010 for review). Anxiety is associated with pessimism (MacLeod & Byrne 1996; Zenger et al. 2010), and selective processing of threat cues (Mathews & MacLeod 1985). Measuring cognitive biases in animals may give us an objective insight into their emotional state, allowing us to assess their welfare in light of what makes them “happy” rather than what makes them distressed.

Animal welfare researchers are now applying the concept of optimism and pessimism to animals, using it to refer to expectation or judgement biases. A judgement bias refers to how animals interpret ambiguous signals and whether they expect more positive or negative outcomes. Judgement bias is a specific type of cognitive bias. Henceforth, cognitive bias will be used when referring to multiple types of cognitive biases and judgement bias will be used when referring specifically to judgement bias. A negative affective state leads to an expectation of negative outcomes and a negative bias in the interpretation of ambiguous signals. This is being referred to in the nascent animal cognitive bias literature as pessimism (e.g. Bateson & Matheson 2007; Burman et al. 2009). A positive affective state leads to an expectation of positive outcomes and positive biases in signal interpretation, which is being referred to as optimism (e.g. Matheson et al. 2008; Brydges et al. 2011). Environmental conditions that induce either a state of positive or negative affect can be used to test this concept in animals by changing environmental conditions to induce positive or negative affect and then testing whether cognitive bias changes correspondingly. Judgement bias has been reported in rats (Burman, et al. 2008a; Harding et al.

2004), starlings (Brilot et al. 2010; Matheson et al. 2008; Bateson & Matheson 2007; Douglas et al. 2012; Brydges et al. 2011), sheep (Doyle, et al. 2010a; Doyle et al. 2011; Destrez et al. 2012), chickens (Lindström 2010; Salmeto et al. 2010), cats (Tami et al. 2011), macaques (Bethell et al. 2012), pigs (Douglas et al. 2012), dogs (Mendl et al. 2010a; Burman et al. 2011) and even honeybees (Bateson et al. 2011). In the species studied to date, negative judgement biases tend to positively correlate with conditions known to induce negative affect, and positive judgement biases positively correlate with conditions known to induce positive affect. These results support the use of cognitive bias in animals as a potential indicator of both positive and negative affective state.

Personality and behavioural syndromes may affect an animal's performance in a cognitive bias test. Some studies have found that individuals that display more stereotypic behaviour than their conspecifics are also more likely to be more pessimistic (Brilot et al. 2010; Bethell et al. 2012). If all individuals within a given population are assumed to be equally prone to optimism or pessimism, using cognitive bias as a welfare assessment tool would be relatively straight forward. However, if individuals differ in their inherent tendencies towards optimism or pessimism, any assessment of welfare should take this inherent tendency into account. An animal prone to pessimism testing pessimistic may be a different level of concern than an animal that is usually optimistic testing pessimistic.

The use of cognitive biases in animals as an indicator of emotional state may potentially go beyond welfare. It may be that a tendency towards optimism or pessimism is a personality trait (Sheppard & Mills 2002). A human is considered to display "dispositional optimism" when they routinely tend to expect favourable outcomes more often than unfavourable outcomes (Nes & Segerstrom 2006). This may align with coping styles, with optimistic individuals tending to approach problems when they appear rather than avoid them (Nes & Segerstrom 2006) as proactive individuals do. Optimistic human individuals are typically less stressed in general, and better able to cope with a large variety of stressful situations than more pessimistic individuals (Andersson 1996).

Studies on humans have found evidence to suggest that hedonic capacity and sensitivity to aversive stimuli may be heritable (Bogdan & Pizzagalli 2008). Correlations between optimism and personality in dogs may enable the identification of individual dogs with a high likelihood of successfully completing training for highly demanding jobs, such as police dogs or drug detection dogs. Generalised Anxiety Disorder is linked with a tendency towards expecting more negative outcomes in humans (Miranda and Mennin 2007a). It has also been found that pessimistic cancer patients have a higher rate of anxiety and depression than optimistic cancer patients (Schou et al. 2004). It is possible pessimistic dogs may share some of those tendencies of pessimistic humans. For example, pessimism in dogs may be linked to a high likelihood of developing anxiety-related behavioural problems such as separation anxiety disorder.

1.4.2. Validating Indicators of Affective State

Validating indicators of affective state in animals is very difficult, largely due to the problems with identifying universally positive and negative stimuli and individual differences in perception of pain and hedonic capacity as previously discussed. The chronic mild stress (CMS) model where animals are exposed to a series of mild stressors such as increased periods of illumination and cage disturbances has been well established as an animal model for anhedonia, which is the main symptom of melancholic depression in humans (see Willner 1997 for review). This paradigm has been used to induce negative affective state in animals in order to study indicators of negative affect. Rats kept under the CMS paradigm have been found to be more pessimistic (Harding et al. 2004), and lambs kept under a similar regime also were found to be more pessimistic than controls (Doyle et al. 2011). However, one potential problem with using the CMS paradigm is that it is designed to induce anhedonia, and as such, animals in this state may be poorly motivated to seek food rewards and show decreased physical activity, both associated with depression and anhedonia (Willner 1998). An alternative method of inducing a negative emotional state is to manipulate the animal's environment. The benefits of environmental enrichment are well known and include a reduction in plasma cortisol and increase in brain weight

and neuron density (see Young 2003 for review). It is assumed such conditions are associated with a positive affective state, and therefore removing enrichment would be associated with a negative affective state. Evidence for this exists from judgement bias studies where indeed, moving an animal from an enriched to an unenriched environment induces pessimism (Bateson & Matheson 2007; Burman, et al. 2008a), and moving an animal from an unenriched environment to an enriched environment induces optimism (Matheson et al. 2008; Douglas et al. 2012; Brydges et al. 2011; Lindström 2010). Similar manipulations have used a single stimulus assumed to induce a negative affective state such as social separation (Salmeto et al. 2010), predatory attack (Bateson et al. 2011), and increased light (Burman et al. 2009), and the animals subjected to these stimuli all tested more pessimistic than controls. However, pessimism was not induced by separating dogs from their owners (Müller et al. 2012), and optimism did not increase after giving dogs a rewarding foraging task to do (Burman et al. 2011). Nor did sheep restrained and socially isolated for a long period show increased pessimism – on the contrary, they showed more optimism than control sheep (Doyle et al. 2010a). Although these experiments used a different means of inducing negative affect than the CMS paradigm, it is still possible the animals subjected to the negative stimuli and living conditions were showing confounding symptoms of anhedonia and depression (Harding et al. 2004; Matheson et al. 2008). Furthermore, there are other relevant conditions that may lead to elevated or reduced physical activity. For example, separation anxiety is associated with elevated physical activity at separation and reunion with an attachment figure (Konok et al. 2011).

Several methods have been employed to separate the effects of anhedonia and cognitive bias. Changing the task from a go/no-go to an active choice task is designed to force the animal to perform a behaviour regardless of the predicted outcome, meaning there is no difference in physical activity between the choices and therefore removing the possible influence of lowered physical activity and reduced motivation on whether the animal seeks rewards or not (e.g. Matheson et al. 2008). This approach adds a layer of complexity to the discrimination task animals are required to learn before their judgement bias can be probed, and

perhaps this is why it has not been taken up. Instead, judgement biases has been linked with physiological and behavioural measures that have themselves been validated as measures of internal state. Mean normal-to-normal heart beat was significantly higher in sheep exposed to a chronic, intermittent stressor regime similar to a CMS regime than controls, and sheep in the stressed group were more pessimistic than controls (Doyle et al. 2011). However, there was no difference in plasma cortisol concentrations between stressed sheep and controls, although this was not necessarily expected (Doyle et al. 2011). Reductions in dopamine, serotonin and octopamine concentrations in bees were associated with pessimism induced by simulated predatory attack, showing that physiological changes consistent with predictions are involved in changes in judgement bias (Bateson et al. 2011). Furthermore, pessimism has been reduced in lambs with the use of drugs designed to reduce fear (Destrez et al. 2012). Studies that have looked at latencies or physical activity in relation to performance in judgement bias tasks have not found pessimistic animals to be slower or less physically active than controls or more optimistic animals (Harding et al. 2004; Mendl et al. 2010b), suggesting that the possible confounding effects of anhedonia may be over-stated in many domestic and laboratory animal populations. However, there are few studies that have addressed this and it may warrant further investigation.

One relatively simple means of exploring the relationship between physical activity and affective state is to measure both. Measuring physical activity in a group of study animals may be time consuming, and in companion animals that may live with a human family, logistically difficult. Fitting animals with activity monitors such as pedometers may represent a solution. The use of commercially available uniaxial pedometers designed for human use to measure physical activity in dogs has been reported on, but with mixed findings indicating some discrepancies in steps recorded depending on body size (Chan et al. 2005; Warren et al. 2011). The use of more expensive triaxial pedometers known as activity monitors has been validated and shown to be a good measure of physical activity in dogs (Brown et al. 2010a; Nuttall & McEwan 2006; Plant 2008). However, the two types of pedometer have not been compared, so it is unknown

whether they can be used interchangeably. Given the triaxial pedometers are very expensive compared to the uniaxial models, knowing the error margin between the models may enable studies with smaller budgets to investigate physical activity in dogs and be well informed of the reliability of the measures obtained. Chapter 6 presents a published paper that compares triaxial and uniaxial pedometers in measuring physical activity in dogs. Not only is this a valuable contribution to the study of affective state, arousal, and personality in dogs, but also in the treatment of many canine illnesses and conditions that may impact on dog health and wellbeing.

1.5. Arousal

Arousal is perhaps the final major piece of the puzzle of dog personality and behavioural variability. Arousal refers to physiological and psychological activation into a state of general wakefulness or attention (Moruzzi 1969). Although the concept has been around for a long time and is known to affect behaviour, it remains a topic rarely discussed in relation to animal personality. This is a peculiar state of affairs, but may come down to the lack of a framework to place arousal in the context of behavioural variability and emotional states. There are also potential difficulties in measuring it, as there is no index and measurement is usually done through invasive means such as measuring physiological signs known to increase in association with arousal, such as tachycardia, hypotension and pupil dilation (Bradley et al. 2008; Jones 2003) and changes in skin-conductance levels (Williams et al. 2001). Arousal here is considered a different construct to that of motivation. Arousal refers to a general physiological activation, whereas motivation refers to specific goal-oriented behaviour. Motivation is defined as processes and structures of an organism directing action towards the satisfaction of needs (Hebb 1949; Deci & Ryan 1985), and is often used to describe the incentive of an individual to carry out a behaviour to satisfy a biological need (e.g. Ågmo et al. 2007).

Arousal was first conceptualised as a generalised construct, where one dimension accounts for arousal in all circumstances. The Yerkes-Dodson Law is

the most famous general arousal construct. The original work on rats in mazes showed that formation of a habit will improve with increased stimulus strength until an optimal level of stimulus strength is reached, after which, increased stimulus strength will be associated with decreased habit formation (Yerkes & Dodson 1908). This was later adapted to suit arousal and performance, with performance increasing with arousal to an optimal point after which performance decreases with additional arousal (e.g. Broadhurst 1957). This led to the concept of optimal arousal, where the arousal level associated with the highest performance in a task may be considered optimal for that task. Optimal arousal level under this construct is believed to be task-specific: lower for difficult tasks than easy tasks. Where arousal is below the optimal level, under-stimulation may result in slow performance or lack of interest in performing at all. Where arousal is above the optimal level, performance suffers due to narrowing of focus so that only a few cues can be attended to – known as the cue utilisation theory (see Hanoch 2004 for review and discussion). The inverted-U relationship became very popular, and experimental evidence from recent studies supports the existence of this effect (e.g. Mair et al. 2011).

The Yerkes-Dodson law is not universally accepted in the literature (Robbins 1997; Hanoch 2004). Related empirical studies have produced mixed results, arguably because the unitary inverted-U relationship is overly simple (Hanoch 2004). Indeed, the original study by Yerkes and Dodson (Yerkes & Dodson 1908) showed a linear relationship rather than the inverted-U in the 'easy' condition. Some researchers have argued that variations in the results of emotional arousal and performance studies reflect differences in experimental measures of performance and approaches to the manipulation of arousal (Hanoch 2004). It may be argued that arousal is an adaptive process that has evolved to help solve problems animals regularly encounter, and therefore high arousal states produce the behaviour needed to cope with specific problems (Hanoch 2004). If performance is measured by how quickly and appropriately animals respond to a specific arousal-inducing stimulus, rather than how they perform in an arbitrarily assigned task that is unrelated, we may see a linear relationship between arousal and performance such as Yerkes and Dodson (1908) found in

their 'easy' condition (discrimination between two visual cues with a large difference in brightness) rather than the famous inverted-U curve.

Current concepts of arousal include both a general arousal construct associated with the central nervous system (Pfaff et al. 2008) and specific arousal types under the influence of the general arousal construct. Evidence for this system of arousal can be found in some studies. For example, when animals are in a state of heightened arousal, they are more active and become more responsive to all types of sensory stimuli, suggesting a general arousal system, but may also become primed to engage in goal-seeking behaviour, suggesting a specific arousal type (Jing et al. 2009). A multiple arousal construct would have several types of arousal, each for a specific type of response (e.g., feeding, locomotion, flight response etc.), under the influence of a general arousal system (see Jing et al. 2009 for review). Combining this arousal construct with the contribution of the affective state on cognitive processes in animals presents an opportunity to form a comprehensive picture of the effect of these variables on training outcomes. An affective neuroscience construct developed by Panksepp (1998) uses the concept of modes based on neural substrates to classify specific emotional states related to common behaviour in mammals. This may be viewed as a dimension additional to the multiple arousal constructs based also on specific responses. This is potentially a helpful start in integrating emotional states and arousal with behavioural output. However, in a practical sense, it is difficult to apply either construct to animal training scenarios. We may align the emotional mode of SEEKING with the arousal associated with foraging, for example, and consider it a harmonious state for training to occur, where trainers may get maximal commitment and focus from their animal trainees. Beyond such broad adoptions, there are difficulties associated with specifics, such as how to identify when the animals are in such a harmonious state and when they have slipped out of it, to where, and why. It is likely there is overlap between neural substrates and associated goal-oriented behaviour. For example, there is likely to be an overlap between RAGE and FEAR systems in defensive behaviour and RAGE and SEEKING systems in inter-male aggression (Panksepp 1998, pp.199-

203). These overlapping modes, while accepted as the nature of emotional states, may serve to confuse practitioners in application.

There is also evidence that different types of arousal may interact with each other, having broad effects on multiple classes of behaviour, such as feeding and sexual behaviour, or feeding and defence (Jing et al. 2009). Moderately aversive or threatening stimuli can promote both defensive behaviours such as flight and competing behaviours such as feeding (Antelman & Szechtman 1975; Kalen et al. 1989), grooming (Rowell 1961) and sexual responses (Barfield & Sachs 1968), suggesting that either such noxious stimuli may act directly on different arousal systems, or indirectly on a general arousal system that may, in turn, provoke varied responses (Jing et al. 2009). Research on molluscs suggests that there are specific and nonspecific effects of arousal (see Jing et al. 2009). Specific effects refer to the enhancement of behaviours directly related to a goal-oriented state, such as feeding or defence, and nonspecific effects refer to effects on behaviours not related directly to the goal, but are important components of the overall aroused state (Jing et al. 2009).

Developing a framework that places arousal in the context of dog behaviour and training may have far-reaching effects on how we train dogs, interpret their behaviour, and improve our ability to predict their behaviour in particular circumstances. This, in turn, is likely to have a positive effect on affective state in dogs, and therefore welfare. As such, arousal is a pivotal concept that belongs in the exploration of dog behaviour and personality that the current work represents.

1.6. Safety Signals

Safety signals are a phenomenon described in the psychology literature that may be highly relevant to training and managing dogs with the aim of promoting optimal arousal levels and positive affective state. A safety signal is a stimulus that predicts the non-occurrence of an aversive stimulus that has become expected, and as such, it acts to inhibit fear responses (Gray 1987). This effect

generalises so that the safety signal can have the same effect in novel situations where the aversive stimulus used to condition the safety signal has never occurred in the animal's experience. As such, a safety signal is expected to reduce arousal in the presence of an aversive stimulus.

There are some inconsistencies in the safety signal literature. In addition to the definition given in the previous paragraph, safety signals have also been adopted to label signals that inform an organism that they are safe (Seligman 1968), or to signal a generalised absence of aversive stimuli. The latter has been used to describe training procedures that do not use an aversive stimulus, but associate the safety signal with a state of relaxation (Haug 2008). For the sake of clarity, it may be most accurate to refer to signals associated specifically with the non-occurrence of aversive stimuli as safety signals, and the subsequent generalisation of fear inhibition as 'learned safety' (Pollak et al. 2008). The more informal use of the term to refer to a signal to enter a state of relaxation, while maybe not technically a safety signal, may deserve consideration in a review of possible uses of safety signals in training and management all the same. It is considered that an understanding of safety signals may aid human trainers and handlers in lowering the arousal and inhibiting fear responses of dogs where the presence of aversive stimuli may provoke dangerous or problematic behaviours. Indeed, a protocol for treating fear aggression in dogs was developed using a safety signal in the formal sense of the term in combination with training alternative, pro-social (obedience) behaviours, and was purported to be very successful (Tortora 1983). Safety signals are considered in this project not as a topic for study in association with personality research, but as a logical next step in applying what has been learned from theoretical explorations of the dog-human dyad and arousal and affective state in training.

Author Contributions

This chapter includes an original paper published by the peer-reviewed journal "Journal of Veterinary Behavior: Clinical Applications and Research". The candidate contributed to the ideas that form the basis of the paper, developed the majority of the ethograms, and contributed to the writing of the paper. The candidate was working at all times within the Faculty of Veterinary Science under the supervision of Dr Paul McGreevy (primary supervisor) and, remotely, Dr Nicholas Branson (associate supervisor). Dr McGreevy, as first author, played a leading role in finalising the manuscript prior to publication. Dr Branson, Mia Cobb, and Dr Calnon contributed to the ideas and writing of the paper.

The inclusion of co-authors reflects the fact that the work came from an active collaboration between researchers and acknowledges input into team-based research.

Confirmation of Co-Authorship of Unpublished Work

I, *Melissa Starling*, contributed to the writing up of the manuscript entitled "*An overview of the dog-human dyad and ethograms within it*".

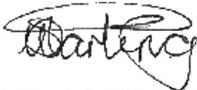
Melissa Starling  Date 9 July 2013

I, as a Co-Author, endorse that this level of contribution by myself and the candidate indicated above is appropriate.

Dr Paul McGreevy  Date 9 July 2013

Dr Nicholas Branson  Date 25 July 2013

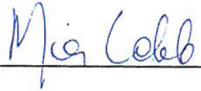
Mia Cobb  Date 03 JULY 2013

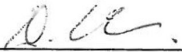
Dr Debbie Calnon  Date 9 July 2013

2 An overview of the dog–human dyad and ethograms within it

P.D. McGreevy^{1*}, M. Starling¹, N.J. Branson², M.L.Cobb^{3, 4} D. Calnon⁵

¹ Faculty of Veterinary Science, University of Sydney, NSW 2006, Australia

² Research Services Division, Deakin University, VIC 3217, Australia

³ Guide Dogs Victoria, Chandler Highway, Kew, Victoria, 3101, Australia

⁴ Anthrozoology Research Group, Monash University, Victoria, 3800, Australia

⁵ Behaviour Counselling Service, P.O. Box 130, Oakleigh South, Victoria 3167,

Australia

This paper has been published in the *Journal of Veterinary Behavior: clinical applications and research*, 2012, 7(2), 103-117.

Abstract

This article reviews the literature on the complex and variable nature of the dog–human dyad and describes the influence of terms such as dominance on attitudes that humans have towards dogs. It highlights a legacy of tension between ethology and psychology and notes that some practitioners have skills with dogs that elude the best learning theorists. Despite the widespread appeal of being able to communicate with dogs as dogs do with one another, attempting to apply the intraspecific dog ethogram to human–dog and dog–human interactions may have limited scope. The balance of learning theory and ethology on our interactions with dogs is sometimes elusive but should spur the scientific community to examine skills the most effective new humane practitioners deploy. This process will demystify so-called “whispering” techniques and permit discourse on the reasons some training and handling techniques are more effective, relevant and humane than others. This article explores the mismatch between the two species’ use of non-verbal communication and offers a framework for future studies in this domain. Technologies emerging from equitation science may help to disclose confusing interventions via the collar and lead and thus define effective and humane use of negative reinforcement. The case for a validated intraspecific and interspecific canid ethogram is also made.

Keywords: dog-human interactions, intraspecific communication, interspecific communication, dominance, submission, deference

Introduction

In the 17th century, English law viewed animals as guilty of their actions. For example, “When in 1679 a London woman swung at Tyburn for bestiality, her canine partner in crime suffered the same punishment on the same grounds”. By the end of the 19th century, the law had changed to view animals as the property of their human owners and it remains this way in many countries today. As science began to reveal that nature could be subject to human control, the perception that people were vulnerable to the metaphorical mystique of animals

was rationalised under the banners of zoology, taxonomy and veterinary science. The accompanying shift in the nature of the relationship between humans and animals that remains today is that animals became objects of human manipulation. For a detailed review of the social domination of animals in the Victorian era, we refer the reader to Ritvo (1990).

Since the first half of the 19th century, the sentimental value of companion dogs has continued to increase. At its best, the dog–human relationship is characterised by strong attachment and the optimal wellbeing of both dogs (Gácsi et al. 2009a) and humans (Barker et al. 2003). At its worst, the dog-human relationship is associated with animal abuse (Ascione 2008) and the routine destruction of unwanted and abandoned dogs (McGreevy & Bennett 2010). Canine behaviour problems can have an adverse impact on the wellbeing of owners and the wider community (Voith 2009), while the abandonment or loss of companion animals can also be associated with human psychopathology (Hunt et al. 2008). For these reasons, harmony between the two species is of critical importance.

To better understand canine social behaviour and, in turn, the dog-human dyad, we do well to first study the ways in which social harmony is created and maintained in stable groups of dogs. The peacefulness that usually defines such established dog communities reminds us that there are very few breaches of social order and that aggression is rare (Bradshaw et al. 2009). This is underpinned by clear signalling and deference, delivered not demanded. Rough physical contact is far more often part of play than of violence and it is foreshadowed by strong signals (Horowitz 2008).

This paper will review the literature relating to our current understanding of the complex nature of the dog–human dyad and examine its characteristics. First, it considers the origins of social-domination belief systems and how social order is usually studied. Second, it reviews canine social behaviour and social learning. Third, it examines canine–human interactions, examining the extent to which they reflect or are informed by the canine ethogram and by learning theory. We

summarise by exploring our ability to apply the canine social ethogram to handling and training and assess the limitations of this approach and we suggest that it is possible to estimate the contribution of ethological and psychological principles in the manifestations of certain responses. However, the emphasis here is on estimation, we are not suggesting that we can quantify the absolute roles of learned rather than innate responses. Context can determine whether learning theory will have a greater influence or be more informative than ethology when training and handling animals (McGreevy et al. 2009a), so we avoid using cues of ethological significance if they run counter to a given training outcome. For example, because it so reliably triggers playful responses rather than conditioned responses, play-bowing (an innate canine meta-signal for play) is rarely used as a visual discriminative stimulus in training. Using this approach, we offer a framework that helps to describe this effect in dog-human interactions.

Origins and implications of the social dominance belief system

Social order can be understood as the product of dynamic and situation-specific relationships between members of a social group (Petherick 2010). Social organisation in *Canis familiaris* can be studied by observing the way in which dogs gain access to and retain resources (Drews 1993). Dominance is characterised as an aspect of a relationship between two or more animals in a social grouping rather than an attribute or trait of an individual. The 'dominant' animal is considered to have higher status over another or others in the group (Petherick 2010). A dominance relationship involves a simultaneous expression of both dominance and submission (Schenkel 1967). A dominance relationship can be established without any sign of aggression only indicated by a submissive or appeasing posture from one of the protagonists. An appeasing attitude from the dog towards humans may therefore indicate a man/dog dominance relationship. An individual dog's motivation to gain access to a particular resource may be subject to some flux (Bradshaw et al. 2009) and resource-holding potential may be context-specific (Shepherd 2002), but this should not demean its importance. The ability to learn is similarly context-specific (McGreevy & Boakes 2007). It is clear that dogs view humans differently from

the way they view other dogs (e.g. Rooney et al. 2000). Nevertheless, we would do well to study the role of intraspecific canine social interactions in dog–human interactions and human–dog interactions, if for no other reason than that humans are regularly bitten by dogs defending certain resources. Aggression is defined as deliberate threat and/or attack components of agonistic behaviour with potential to cause injury associated with conflict and competition (Brain 2010). Recent data suggest that higher scores for owner-directed aggression are associated with male dogs and female owners (Hsu & Sun 2010) but this does not necessarily indicate social dominance as a cause. It is critical that the role of testosterone in impulsive and reactive aggression among companion dogs is better understood. And only when we study how aggression and successful affiliative activities (such as play) (Horowitz 2009) emerge in dog–dog dyads, will the subtleties of dog body language and our ability to offend our canine companions, however inadvertently, become clear.

Social order helps animals within a social group learn which of them can defend resources and displace another from them (McGreevy 2004). This learning is underpinned by communication and effectively reduces aggression (McGreevy 2009). It can exist without the necessity for individuals to have a sense or concept of their own status. Humans have gone to great lengths to interpret animal behaviour in terms of social order. Some of the theoretical constructs that have arisen in the process, such as ‘dominance’, have acted as obstacles to successfully extending our understanding of animal behaviour (Friedman & Brinker 2001). Many authors (Semyonova 2003) criticize labels such as “dominance” because they evoke emotional responses in the observer and can prejudice interpretations, interfere with verifiability of behavioural responses and are tightly bound by the human perspective. It is important to note here that social dominance order (or orientation) is a term used in psychology to describe a personality variable that predicts social and political attitudes. It is distasteful to many because it reflects an individual’s preference for inequality among social groups (Pratto et al. 1994) and may in some ways relate to right-wing authoritarianism.

Non-Western philosophical frameworks, such as Buddhism, believe that animals exist in their own right, rather than as property, as they are represented in Western law. It is therefore pertinent to assess the validity of the dominance construct in terms of Western culture's sanction of the control of man over nature (Misra 1995).

In addition to the effect of cultural attitudes, it is also worth considering the potential effect of inattentional blindness on human perception of dog behaviour. Inattentional blindness is the notion that "we rarely see what we are looking at unless our attention is directed to it" (Mack 2003). This concept highlights the intimate link between our perception and our attention. Steinker (2007) argued that by labelling a dog as "dominant", the humans involved begin to interpret many behaviours as evidence of "dominance" and ignore any evidence to the contrary. The concept of inattentional blindness may further assist with understanding why people are very likely to see, remember and interpret dog-dog and dog-human interaction in terms of the dominance framework with which they are familiar. This concept illustrates the power of our intentions in determining what we see and what we do not (Mack 2003).

On a practical level, it is clear that some practitioners have skills with dogs that elude the best learning theorists; they may insist that they are using canine ethology and imposing canine social order to communicate with dogs. As a result, the role of dog owners and handlers as leaders, alphas and trainers is widely debated. A popular view that has, until recently, prevailed in dog-training circles is that dog-dog interactions mirror wolf-wolf interactions. An example is provided by Bauer and Smuts (2007), who stated that "as studies of captive wolves found that postural asymmetries were consistently unidirectional within dyads and that dominance hierarchies based on these postures showed a high degree of linearity ... such postures were therefore considered reliable indicators of dominance for our purposes" [in studying companion dogs]. These authors then went on to draw conclusions about play behaviour in companion dogs based on their relative dominant status that were based on wolf data.

Bradshaw et al. (2009) reviewed data available on social hierarchy in the dog from the perspective of dominance hierarchy. It seems that, historically, the suggestion that humans could and should adopt the role of pack leader was based on two implicit assumptions: first, that wolves are the ancestors of domestic dogs, and second, that a linear hierarchy existed in wolf packs (van Kerkhove 2004). While the first point is widely accepted, the second has been challenged [reviewed by (Bradshaw et al. 2009; van Kerkhove 2004; Steinker 2007; Semyonova 2003)]. The merits of the putative linear hierarchy of wolf social order as an appropriate model to apply to the social behaviour of domestic dogs has been widely discussed (van Kerkhove 2004; Scott & Fuller 1965; Serpell 1995; Bradshaw et al. 2009; Steinker 2007).

Mech (1999) described 13 years of studying the social order within wild wolf packs and the results of this research contradict most of the widely held beliefs regarding dominance hierarchies in this species that have been assumed to be applicable to the domestic dog. He found that family groups, rather than a linear hierarchy, were observed in wild wolf populations. Based on these results, van Kerkhove (2004) and Yin (2009) have suggested that “wolf pack theory” does not apply to domestic dogs and challenged the idea that humans should maintain social stability in their interactions with dogs by adopting a “top-dog” role. Furthermore, Coppinger (2001) has argued that dogs are not pack animals. That said, there is evidence that, where resources are sufficient, large groups of dogs can occupy a single area with minimal conflict (Bradshaw et al. 2009) and that dogs can cooperate in tasks (McGreevy 2009).

Scott & Fuller (1965) believed that social hierarchies effectively reduce and minimise overt aggression between individual members of the pack but noted that a linear hierarchy does not appear to be a factor for the domestic dog in maintaining social harmony. They evaluated social order in their study using a “dominance test” on puppies at 5, 11 and 15 weeks of age. Two puppies were placed in a pen with a bone for 10 minutes. Dominance was defined as a condition in which one puppy kept possession of the bone for at least 8 out of 10 minutes. The dogs were rated as “dominant”, “incompletely dominant” and

“subordinate” and the effect of dominance on the amount of fighting was assessed. The observations varied across three breeds: Fox terrier, Basenji and Shetland sheepdogs. Breed differences were found in the association between “dominance” (defined as control over a bone) and an effective control system over fights between individuals. Thus, the notion that dominance order could control fighting was upheld in two of three breeds of dogs when observed between 5 and 15 weeks of age. However, if we place these findings in the context of the difficulty other scientists face when attempting to develop tests in puppies that predict their behaviour as adults (Wilsson & Sundgren 1998; Batt et al. 2010), we can only speculate how any association between dominance and fighting might vary in dogs of other ages, let alone in other breeds.

Scott & Fuller (1965) described nine fundamental behavioural systems for dogs (investigative behaviour, epimeletic behaviour, et-epimeletic behaviour, allelomimetic behaviour, agonistic behaviour, sexual behaviour, eliminative behaviour, ingestive behaviour and comfort-seeking behaviour [shelter-seeking]). They concluded that not only were these relevant to dogs of all breeds, they were also relevant as a framework for comparing human and dog behaviour patterns. While acknowledging that, in many ways, dogs and humans are different in terms of anatomy, physiology and behaviour, these authors noted that social behaviour patterns are similar enough, in many contexts, to be mutually recognisable.

A brief consideration of analogues of dog–dog interactions that arise in human–dog dyads suggests that there are at least some human–dog interactions that align with the canid intraspecific social ethogram. Analogues, such as allogrooming, can be useful for humans needing to groom dogs (McGreevy et al. 2005a), whereas others may raise challenges because there can be tension between ethological and psychological constructs in training. For example, while gaze-averting is a deference display in dogs (Vas et al. 2005), during some training sessions, it is critical to keep a dog’s attention focused on the handler. Furthermore, breed differences in attention to human cues have been demonstrated (Gácsi et al. 2009b), and differences in aloofness (McGreevy

2007a) and even retinal anatomy (McGreevy et al. 2004) may account for the lack of attention some dogs pay their handlers.

Vas et al. (2005) developed a scale for assessing behavioural responses of dogs to approaches by unfamiliar humans. These authors note that humans may have selected dogs based, inter alia, on variation in monitoring of and response to human cues. Certainly, this could be a first step in selecting dogs that may excel at protection, guarding and herding, all of which share related behaviours.

Dogs have been selected for adaptations to human social life, and these adaptations have led to marked changes in their communicative, social, cooperative and attachment behaviours towards humans. In a review of canine social cognition, Miklósi et al. (2004) state that through a complex evolutionary process, dogs became adapted for living in human society. Therefore, the human environment and social setting now represents a natural ecological niche for this species. Dogs are extremely flexible in how they process spatial information and can simultaneously use cues from different sources and rank the cues based on the complexity of the environment (Fiset et al. 2005; Fiset & LeBlanc 2006; Fiset et al. 2000). If humans are part of that environment, we must consider that dogs trained to work in the presence of humans who issue discriminative stimuli may disregard information that they, themselves, collected (Szetei et al. 2003). Given that companion dogs behaved differently (attempted a forbidden task) when the owners were in the room compared with when they were not in the room (Schwab & Huber 2006; Horowitz 2009), it seems likely that intimate human–dog relationships (as occur in companion dogs) may predispose dogs to behave in a socially dependent fashion. All of this suggests that canine scientists seeking to advance communication in the dog–human dyad must grant ethologically relevant mechanisms as much attention as mechanisms that align with learning theory (McGreevy & Boakes 2007).

Studying domestic canid social order

Bradshaw et al. (Bradshaw et al. 2009) posit that Resource Holding Potential (RHP) (Parker 1974) may be less applicable to dogs than to other species, but that nevertheless it is useful because it offers the concept of subjective resource

value (V) as a factor influencing the escalation of conflicts. Bradshaw et al. (Bradshaw et al. 2009) propose that V, in combination with associative learning, explains antagonistic encounters between dogs more simply than traditional dominance theory. This is a useful contribution to explain resource-related aggression but it fails to either acknowledge the possible role of personality dimensions or explain the mechanisms of dog–dog antagonistic interactions in the *absence* of clearly disputed resources.

It could be argued that encounters between two members of a dyad are never resource-neutral. Fighting may be exhibited in different contexts, including competition over a resource, and contexts not clearly related to resource possession (Hahn & Wright 1998; cited by Wright 2004). For example, when dogs first meet, one of them is more the territory holder than the other (even if only by virtue of being on that site for longer than the protagonist) and perhaps presence on the territory is a quasi-resource. But when meeting for the first time, how can dogs be sure they are valuing or fighting over the same resource? Before any associative learning about their relationship can take place, their behaviour may represent a manifestation of positive and negative personality dimensions such as those described by Sheppard and Mills (Sheppard & Mills 2002) or the five personality factors described by people interviewed in the study by Ley et al. (2008).

A given dog's ability to impose social status at the first meeting would seem to lay the platform for future interactions over resources. For example, an extroverted dog may set the stage for subsequent encounters with an introverted dog over equally valued resources. Some dogs may be unable to interpret the intentions of unfamiliar dogs when they approach conspecifics; they may be less concerned with resources than with the need to obviate a perceived threat. Clinical experience suggests that some dogs will behave in an aggressive manner toward any unfamiliar dog, in any setting, at considerable distances (Debbie Calnon, personal communication). For these dogs, it is very difficult to identify the value of a resource since the most likely primary motivation appears to be fear or anxiety. This prompts us to ask whether access

to self-defence mechanisms (and actions taken to reduce the perceived risk of harm to self) is the resource these dogs value.

Scientists generally base their measurements of social hierarchies on who displaces whom from food and, less often, on who initiates contact with whom. However, it is important to ask whether the order that predicts displacement and appeasement are sometimes based on relative value of resources and sometimes on fear. Regardless, the question is whether such social order among dogs can include humans and whether perceived breaches of order may explain how humans occasionally get bitten. It is possible that inconsistency on the part of humans can create behavioural conflict in nearby dogs and the resultant frustration can trigger aggression. Dogs that bite humans are usually, but not always, thought to bite through fear and anxiety (McGreevy & Calnon 2010). Of course, all non-biting dogs are not necessarily free of fear or anxiety solely because they are sure of their social status. Nevertheless, care is warranted in human activities that may amount to ethologically relevant social threats to dogs.

Conflicts between dogs living in the same household are most often between members of the same sex, and more often involve females than males (Wrubel et al. 2011; Sherman et al. 1996). That said, the triggers for these aggressive encounters are generally reported by dog owners who are untrained in making behavioural observations. It is therefore difficult to identify why these conflicts occur and why they are more prevalent between members of the same sex than members of the opposite sex. Free-ranging dogs living in groups are reported to show a linear hierarchy, but although there are differences in frequency of agonistic interactions between males and females, there is no clear indication there is a separate hierarchy for each sex (Pal et al. 1998). Scott and Fuller (1965) found that when male and female puppies contested a resource, males tended to win. They postulated that this was because males were typically larger. However, between sexes, size had no effect on the outcome of contests in female-female pairs, and only a weak effect in male-male pairs. Scott and Fuller (1965) concluded that a relationship tends to reflect the differential capacities of the two individuals involved. So, dogs of different sex tend to have more defined

relationships, with one member typically playing the dominant role and one the subordinate, whereas dogs of the same sex tend to have relationships that are less well defined with dominant and subordinate roles switching readily. The latter relationship is more likely to trigger aggressive behaviour generated by conflict.

The relevance of canine social behaviour

Moehlman (1987) reminds us that the regulation of social structure and behaviour in wild canids reflects characteristics of the canid (size, weight and sex), the group (group size, territory and reproductive strategies), and access to food (temporal and spatial distribution of prey). Domestication has changed many of these variables beyond recognition, most of all perhaps in the supply of resources, especially food.

Homologous behavioural mechanisms can be identified between wolves and dogs, but the best model for describing social relationships among domesticated dogs reared in a home environment derives from that environment rather than any wild canid social structure (Wright 2004). Much of the work on cognition in dogs has focussed on testing putative effects of domestication of pet dogs and comparing the results to captive, usually hand-reared wolves. Wolves in these populations do not respond to human cues about location of items in the same way that dogs do, leading to the conclusion that “pointing” or “showing” are behaviours developed because of close contact with humans, possibly due to domestication (Miklósi et al. 2007).

The ability of dogs to gain access to particular resources, retain their own resources and displace other dogs from resources is a critical element of social order. Dogs are limited to burying prized objects, but humans can stash resources in pockets, boxes and cupboards that only they can access. Dogs do not feed adult conspecifics nor, for that matter, do they dictate when they take exercise. A dog’s behaviour can be manipulated by identifying resources valued by the individual dog. Resources such as food and exercise can be used by humans to encourage and discourage particular canine behaviours, illustrating

one distinct difference between intra- and inter-specific social relationships. It follows that resource supply, resource guarding and resource-related frustration (on the part of dogs) can prove problematic in some dog–human dyads. Most operant conditioning uses learning theory to modify dog behaviour. We control access to the resources and, using them, can train all the behaviours we regard as desirable. This is something other dogs do not appear to do as effectively as we do. So, again, we need to be cautious, because it may be wrong to assume that dogs want to control other dogs through access to resources. From ethological descriptors, a social animal is accorded rank through its ability to gain access to specific resources. However, we emphasize that it does not follow that the animal is motivated to take control of resources to attain rank. In other words the animal is not motivated by a desire to be dominant for the sake of attaining rank *per se*.

The role of social learning

Social learning occurs when an individual learns by observation of another individual (Ligout 2010). In some species, such as domestic chickens, the social status of the demonstrator has a strong influence on the perceived value of the information it imparts (Nicol & Pope 1999). Social learning is an important aspect of the dog's social behaviour (Horowitz 2008), so we should consider how canine ethology informs the way in which we apply learning theory. Cognitive tests can include truly novel components that require learning during the test, including situations where dogs learn from watching other dogs successfully perform and be rewarded for performing a novel task (Range et al. 2009). It has been shown that the pups of trained drug-detection bitches learned to pay attention to target odours from watching their mothers (Slabbert & Rasa 1997). In another study, observer dogs were able to adjust their search behaviour for hidden food depending on the knowledge gained by observing and interacting with a conspecific (Heberlein & Turner 2009). It has also been shown that subordinate dogs, as defined by the balance of leadership and deferential behaviour, learned a detour task more quickly than dominant dogs if they observed it demonstrated by another dog, but there was no difference if the demonstrator was human (Pongrácz et al. 2008). In a study of 118 dogs split into

two groups, the group that watched a human manipulate a test/treat box was faster in successfully opening the box and spent more time interacting with it than the group that did not (Marshall-Pescini et al. 2009). So we should consider the extent to which dogs may learn from us with no intended operant conditioning. The prospect of being able to model behaviours for dogs to adopt mimicry is beguiling and is strongly hinted at by studies of model-rival (McKinley & Young 2003) and possibly also the effect of pointing and referential gazing (Elgier et al. 2009; Gácsi, McGreevy, et al. 2009b; Gácsi et al. 2009a).

Canine-human interactions

Among the challenges to understanding the way dogs fit in or not to human households are the variability of dog-keeping styles (Masters & McGreevy 2008) and human personality types (McCrae et al. 1999). Households can be occupied by single or multiple dogs just as they can be by single or multiple humans (McGreevy & Masters 2008).

In what remains the largest dog behaviour research project of its kind, Scott and Fuller (1965) acknowledged that the chief relationships they studied were the human males with young dogs and human females with young dogs. The gender of human participants in dog-human dyads is of fundamental importance. While we know that dogs' cortisol concentrations often reduce with human interaction in general (Hennessy et al. 2001; Tuber et al. 1996), there is evidence of a more marked reduction in cortisol responses in shelter dogs when being stroked by women (Hennessy et al. 1998).

Scott & Fuller (1965) described the complexity of dog-human interactions and noted that these are variable and capable of change. They identified 21 possible different types of social relationships between entire dogs and humans. As so many domestic dogs are sexually neutered, we added the extra categories of neutered male and neutered female to the original table from Scott and Fuller (1965). The amended version of this table is reproduced below (Table 2.1) and shows 27 possible different types of social relationships between dogs and humans.

| | DOG | | | HUMAN | | |
|--------------------|-----------|-------------|------------|-----------|-------------|------------|
| | Male (MD) | Female (FD) | Young (YD) | Male (MH) | Female (FH) | Young (YH) |
| DOG | | | | | | |
| Male | MD-MD | | | | | |
| Male Neuter (MN) | MN-MD | MN-FD | MN-YD | | | |
| Female | FD-MD | FD-FD | FD-YD | | | |
| Female Neuter (FN) | FN-MD | FN-FD | FN-YD | | | |
| Young | YD-MD | YD-FD | | | | |
| HUMAN | | | | | | |
| Male | MH-MD | MH-FD | MH-YD | MH-MH | | |
| Female | FH-MD | FH-FD | FH-YD | FH-MH | FH-FH | |
| Young | YH-MD | YH_FD | YH-YD | YH-MH | YH-FH | YH-YH |

Table 2.1. Fundamental classification of social relationships of dogs and humans. Adapted from Scott and Fuller (1965).

It seems that, within contemporary households, dogs may have negligible, frequent or irregular interactions with other dogs or people (McGreevy 2009). So the applicability of canine ethograms may be limited for some dogs living with humans. Indeed, dogs living in single-dog households may not even become fluent in their own language. Whether or not this has an effect on their fluency in communicating with both conspecifics and heterospecifics is worth considering. Evidence of the adaptability and flexibility that dogs have when living and communicating with other species was studied by Feuerstein and Terkel (2008), who found that a first encounter taking place at an early age (up to 6 months in cats and up to 1 year in dogs) enabled most cohabiting dogs and cats to appropriately interpret the particular body language displayed by the other, even when the signal had an opposite meaning for both species. Furthermore, they showed that the younger the animal at first encounter, the better this understanding was, and the more chance there was of establishing an amicable relationship.

Social groups in feral-dog contexts are arguably subject to less flux than those in the human–dog domain. Feral dogs do not meet strangers in their den on a regular basis, visit parks or go on holidays. Dogs have not evolved to know that

the new social groups that arise in the company of strangers, on a visit to a park or a trip to a holiday destination, are not going to last for the rest of time. Making sense of how these novel groupings will affect access to resources either relies on learning gradually about each resource and who is allowed it and when, or it involves some social order, perhaps based entirely on deference, that removes the need for constant disputes. There seems to be merit in working out swiftly and painlessly who must voluntarily defer to whom. Dogs in the human domain may become highly skilled in responding appropriately to this cognitive challenge.

Notwithstanding the variability described above, it is possible to map out common dog–human and human–dog interactions by following the framework for exploring horse–human interactions offered by McGreevy et al. (2009a). This is discussed further in our concluding suggestions for further research. However, we need to be cautious with this approach. Lit et al. (2010) investigated owner reports of dog–human interactions and showed how complex owners’ interpretations of such interactions can be. Elements of the dog–dog social ethogram may look similar to what humans see when dogs and humans interact but, thus far, we cannot be certain that they look similar to the dog. We must be aware that dogs may not see or interpret these categories in the same way we do. Nevertheless there is merit in offering a framework that has its basis in dog–dog interactions since it may explain where errors in human attempts to communicate with dogs are most likely.

Using our own observations and pooled experience, and acknowledging the importance of breed differences in signaling (Goodwin et al. 1997), we have tabulated the ways in which dogs interact with each other and with us and have contrasted these interactions with some of the activities we impose on dogs using the following six domains:

- Restraint and (giving or receiving) aversive stimuli (Table 2.2).
- Tactile activities (allogrooming and resting) (Table 2.3).
- Meeting unfamiliar individuals (Table 2.4).
- Sharing resources/playing with objects (Table 2.5).

- Greeting familiar individuals and playing without objects (Table 2.6).
- Non-tactile interactions (Table 2.7).

| Dog–dog behaviour | Possible human–dog equivalent (without apparatus) | Dog–human analogue of dog–dog behaviour |
|---|--|---|
| Attempt to escape restraint | Present | Present |
| Bite | Absent | Present |
| Body block | Present | Present* |
| Boxing | Present | Present |
| Grip with mouth/teeth | Present: hold a body part firmly with hand and fingernails | Present |
| Lunge | Present: lunge forward with hands outstretched towards dog | Present |
| Pin with chest/body weight | Possible: pin with hands | Absent – due to relative difference in height |
| Pin with muzzle | Possible: pin with hands | Absent – due to relative difference in height |
| Snap | Possible: quick lunge with one or both hands without contact | Present |
| Stand over | Possible: may do so naturally due to relative height | Absent – due to relative difference in height |
| Threaten to bite as a form of body blocking | Absent | Present |

Table 2.2. A consideration of restraint and (giving or receiving) aversive stimuli as they arise in dog–dog, dog–human and human–dog interactions.

* Impeded by human bipedalism

The instances in which dogs do not react to humans as described in Table 2.2 are usually because of the relative difference in height. Common human–dog interactions in this domain that have no analogue in the canine ethogram include the use of collars, chains, harnesses, headcollars, catch poles, lifting dogs off the ground and confinement.

| Dog–dog behaviour | Human–dog equivalent | Dog–human response? |
|-----------------------------|--|---------------------|
| Grooming nibble | Present: brush/scratch | Present |
| Lick | Present: kiss/ spongeing/wiping | Present |
| Mouth | Present: isolation and restraint of particular body part | Present |
| Nuzzle face/ears | Present: massage face/ears with fingers | Present |
| Resting in physical contact | Present | Present |

Table 2.3. A consideration of tactile activities (allogrooming and resting) in dog–dog, dog–human and human–dog interactions.

Table 2.3 shows that dogs will attempt to use almost all their repertoire of tactile activities with familiar humans. However, common human–dog interactions that have no analogue in the canine ethogram include scratching the chest, putting on collar/harness, combing, brushing, nail-clipping, expressing anal sacs, opening mouth, administering oral medications, applying topical medications, dressing wounds, towelling dry, hands-on training, bathing and cleaning ears, patting as opposed to stroking or scratching, clipping of coat, kicking, pushing and smacking.

| Dog–dog behaviour | Human–dog equivalent | Dog–human response |
|---------------------------|---|---------------------------|
| Body block | Present | Present |
| Circle | Possible | Present |
| Genital sniffing/licking | Absent | Present |
| Increased postural tonus | Present: stand tall, tension in body | Present |
| Lift paw onto forequarter | Present: place hand on shoulder | Present* |
| Lunge | Present: lunge forward with hands outstretched toward dog | Present |
| Mount | Possible: when lifting a medium-sized dog | Present* |
| Raise hackles | Absent | Present |
| Snap | Absent | Present |
| Sniff under tail | Absent | Present* |
| Touch noses | Present: not as easily as in dogs. | Present* |

Table 2.4. A consideration of meeting and greeting activities among unfamiliar individuals in dog–dog, dog–human and human–dog dyads.

*Impeded by human bipedalism

Table 2.4 shows that, where our bipedalism does not interfere, dogs generally attempt to use almost all their repertoire of greeting activities with familiar humans. However, our ability to mimic canine responses is severely limited. Furthermore, common human–dog interactions that have no analogue in the canine ethogram include hugging familiar group members, patting on head, ignoring, screaming and running away.

| Dog–dog behaviour | Human–dog equivalent | Dog–human response |
|--------------------------|--------------------------------|---------------------------|
| Nose object | Present: push object with hand | Present |
| Tug | Present | Present |

Table 2.5. A consideration of the ways in which dog–dog, dog–human and human–dog dyads may share resources or play with objects.

There are some compelling analogues in Table 2.5. However, common human–dog interactions that do not align with the canine ethogram include throwing objects, not chasing objects of value (e.g., thrown articles), giving food (including bones, chews, titbits), giving play objects and kicking balls.

| Dog–dog behaviour | Human–dog equivalent | Dog–human response |
|----------------------------|---|--|
| Chase | Present | Present |
| Jaw sparring | Present: tapping either side of jaw with hands while dog tries to catch hands | Absent: due to relative difference in height |
| Mount | Possible: when lifting a medium-sized dog | Present |
| Mouth at legs or neck/face | Absent | Present* |
| Paw | Present: reach out with hand | Present |
| Pounce | Present: lunge | Present |
| Rubbing | Present | Present |
| Wrestling while running | Absent | Present |

Table 2.6. A consideration of the ways in which dog–dog, dog–human and human–dog dyads greet familiar individuals and play without objects.

*Impeded by human bipedalism

We see again, in Table 2.6, that humans struggle to reciprocate in ways that align with the canine ethogram when playing without objects. In addition, common human–dog interactions that have no analogue in the canine ethogram include some of the most popular dog sports: off-lead training, including agility, canine freestyle and tricks. It is worth noting here that, among dogs, it has been found that more advantaged individuals do not consistently relinquish their advantage to facilitate play (Bauer & Smuts 2007). Role reversals do occur, but certain social conventions influence which behaviours could be used during role reversals (Bauer & Smuts 2007).

| Dog-dog behaviour | Human-dog equivalent | Dog-human response? |
|--------------------------|---|----------------------------|
| Avoidance | Present | Present |
| Bare teeth | Present: smile | Present |
| Bark | Present: shout | Present |
| Body shake | Absent | Present |
| Excitement bark | Present: shout | Present |
| Frustration bark | Present: shout | Present |
| Warning growl | Present: can be imitated with low frequency tone of voice | Present |
| Head and neck roll | Absent | Present |
| Lick lips | Present | Present |

| | | |
|---|---|----------|
| Look away | Present: avert eyes | Present |
| Pilo-erection | Absent | Present |
| Play bow | Present: can be imitated | Present* |
| Play growl | Possible: can be imitated with higher frequency tone of voice | Present |
| Prance | Possible: can be imitated | Present* |
| Relaxed gaze into face | Present | Present |
| Stalk | Present: can be imitated | Present* |
| Stare | Present | Present |
| Submission grin | Present: smile | Present |
| Submissive posture e.g. inverted U position | Present: crouch | Present* |
| Tail wag | Absent | Present |
| Whine | Present: can be imitated with high frequency tones and use of Motherese | Present |
| Postural tonus e.g. U-position, stiff legs and movement | Present: when tense or confident | Present* |

Table 2.7. A consideration of the ways in which dog–dog, dog–human and human–dog dyads may communicate using non-tactile mechanisms.

*Impeded by bipedalism

In Table 2.7 the imbalance between the two species appears most striking. There are numerous examples of how humans generally struggle to use elements of the canine ethogram to communicate with dogs. In addition, there are common human–dog interactions with no analogue in the canine ethogram: blowing or whistling in the face, waving arms around, hand signals and gesturing (not pointing) with hands or head.

This examination of intraspecific interactions shows how commonly dogs seem to deploy elements of their social ethogram in interactions with humans and where the limits to these attempts and to reciprocation generally lie. If we consider contexts in which dogs and humans interact, we can make predictions about the outcome of the interactions based on the relative role of learning theory and the canid intraspecific social ethogram (see Table 2.8).

| Context | Alignment with the canid intraspecific social ethogram | Relative role of learning theory <i>“How readily can responses be conditioned?”</i> | The value of the focal resource (V), in combination with associative learning |
|--------------|--|--|---|
| Human taking | +++++ | + | ++++ |

| | | | |
|---------------------------------|-------|-------|------|
| resources from dog | | | |
| Dog taking resources from human | +++++ | +++ | ++++ |
| Dog grooming human | +++++ | + | + |
| Human grooming dog | + | +++ | + |
| Hands-off play and training | ++ | ++++ | ++++ |
| Hands-on play and training | + | +++++ | + |
| Veterinary activities | - | + | - |

Table 2.8. A conceptual tabulation of the relative roles of learning theory, the value of resources and the canid intraspecific social ethogram in various common contexts.

Table 2.8 demonstrates how regularly the most common human physical interactions (restraint, brushing and combing, training, feeding, watering, and veterinary care) have no analogue in the canine social ethogram and how patchy is the human’s ability to offer plausible analogues of dog–dog interactions. Taken together, Tables 2.2-2.8 show the many ways in which dogs may attempt to use their social skills on humans, where their height permits and our bipedalism does not obstruct such attempts. But they also seem to demonstrate that, when we consider dog training and handling, there are limitations to the usefulness of both the canid ethogram and learning theory. These limitations are discussed further below but, taken together, our shortcomings in the use of the canid ethogram to communicate with dogs should remind us that successful dog handling is not successful dog mimicry. However, by the very same token, we need to acknowledge that these limitations can help to explain instances of dogs biting humans in the absence of fear or anxiety. For example, making the wrong move when a dog has placed its forepaws on one’s shoulder while staring you in the face can trigger a bite (McGreevy 2009).

Applying the canid ethogram to dog–human dyads

Aspects of our body language and behaviour may stimulate resource-guarding and forms of anxiety in dogs. Human activities that displace a dog may culminate in a bite if the dog has learned to defend its resources. Dogs that have been granted free access to some resources as juveniles learn to defend these and, quite plausibly, others. Thus, the value of one resource may have implications for

the unexpected defence of others. It is easy to see how this could lead to unanticipated displays of aggression and to a dog being labelled dominant. Our relative height means that dogs automatically look up to us and that this may lend us an ethological advantage. It is possible that this makes us 'super-dogs': initiators of expeditions, exercise, grooming, play and feeding, leaders who would never be worth questioning, but clearly this is simplistic. The evidence presented by Bradshaw et al. (2009) suggests that there is no leader within the dog-dog domain, so consideration should be given as to how dogs could transfer such a role to another species. However, the absence of a clear leader in a study of 19 neutered male dogs presented by Bradshaw et al. (2009) does not imply that humans cannot become integrated into social constructs that have their origins in the social ethology of *Canis familiaris*. Whether dogs have evolved to use their social order skills with another species (most notably humans) is contentious. That said, one of the key aspects of evolving with humans is that dogs have learned to coexist with people, and the fact that dogs have been so successfully used by people demonstrates that an effective means of communication does exist.

Whether dogs have evolved to use their skills for social order with another species (most notably us) is contentious. That said, one of the key aspects of evolving with humans is that dogs have learned to coexist with people, and the fact that dogs have been so successfully used by people demonstrates that an effective means of communication does exist.

The debate between the relative roles of learning and the ethogram mirrors the historic tension between ethology and psychology. On one hand, we have the suggestion that every response a dog makes (including aggression) has to be learned and, on the other hand, we have practitioners proposing that they only have to mimic wolf behaviour to gain compliance and a bond with dogs. The middle ground suggests that dogs are likely to rely on the social repertoire they have evolved to use with other dogs unless they have been socialised with other species.

Communication modalities used in training

Generally speaking, we train dogs with negative reinforcement (NR), positive reinforcement (PR) and punishment. Applying physical pressure-release (NR) and providing reinforcers only when a desired behaviour is performed' (PR) are seldom reported in the canine intraspecific ethogram, so it seems that we generally train dogs with modalities that have minimal inherent relevance to their social learning. This may be a significant failing on our part.

To be effective and safe in interactions with dogs our actions outside operant conditioning rely less on timing and consistency and more on being able to:

- interpret dogs' body language and assess their motivation correctly;
- mimic appropriate elements of the ethogram (e.g., play-bowing), notwithstanding their context-specificity;
- avoid threatening dogs, their young and their resources;
- neither inadvertently nor consistently defer and thus release resources that are valued by the dog;
- offer appropriate models that may be of use in social learning;
- provide useful information (e.g., by pointing at objects and caches of interest).

These seem to be the very qualities that natural dogfolk (and possibly many so-called dog whisperers) possess. Capturing, defining and measuring these qualities and training less gifted handlers to reproduce them may be the enduring legacy of the dog whisperer phenomenon.

Some dogs and some humans seem to have developed their own fluent means of communication. This involves an ability to read body language, perhaps underpinned by a universal interpretation of actions that accompany agonistic responses in both species: fixed stares, stalking and high postural tonus. It may be that dogs learn more quickly when hand signals are used in training rather than words (Soproni et al. 2001; Soproni et al. 2002). This may support the premise that handlers who process ideas or communicate pictorially rather than

verbally have made a big leap in their effort to learn “dog language”, dogs being a visually-oriented (rather than a verbally-oriented) species.

Yin (2002) described the subtypes of barking used by dogs in different contexts but many of the subtleties of canine vocalization remain unknown. Acoustic signals, such as growls, barks and whines, have a role in canine communication. Growls intended as a warning are of a lower frequency than growls in play, and are longer, but growls in play have lower formant frequency dispersions than aggressive growls (Faragó et al. 2010). Formant frequency dispersion is a measure influenced by the length of the vocal tract, thus, a low formant frequency dispersion is a reliable indicator of a larger animal, and a high formant frequency dispersion indicates the sound is coming from a smaller animal (Fitch 1997; Taylor et al. 2009). Barks that signal aggression also have a lower frequency than barks that signal play or ‘happiness’, and have shorter inter-bark intervals (Pongrácz et al. 2006). Growls associated with food-guarding appear to have a strong deterrent effect on other dogs taking a meaty bone, but warning growls associated with a threatening stranger are also low in frequency and have a weaker deterrent effect on dogs taking a meaty (Faragó et al. 2010). This would suggest there are elements of either context or fine acoustic detail that allow dogs to differentiate between two agonistic growls (Faragó et al. 2010). It is possible that dogs interpret low frequency human vocalizations, including warning tones, as potentially threatening and high frequency human vocalizations as potentially playful. However, given the likely importance of context in the interpretation of acoustic signals, it is probable that the frequency of human vocalizations would be interpreted in light of other cues and the history of the dog with those and similar human vocalizations. Conversely, it appears that humans may tend to misinterpret the motivation behind a canine vocalization as aggressive if it has low frequency dispersion and thus sounds like a large dog (Taylor et al. 2010). It is possible there is a perceptual bias in humans to perceive the growls of large dogs as more aggressive than growls of small dogs (Taylor et al. 2009).

Humans can alter the types of vocalizations they give to promote different behavioural responses from dogs. When humans send a signal consisting of short notes, it can elicit a reactive response and increase motor activity levels more than a signal consisting of a longer continuous note (Yeon 2007). Dalibard (2009) studied service dogs via a questionnaire survey and found that voice tone and clarity affected how well and how quickly dogs responded to requests. Coutellier (2006) examined the responses of detection dogs to the voice commands of their handler or a stranger. The response of the dogs differed significantly when the handler and handler's voice were used, compared with the stranger and stranger's voice. There was no difference in response if only the olfactory cues were changed, indicating that dogs partially rely on acoustic information to perform their jobs. Despite the differences in the vocal range of dogs and humans, there are some similarities that make some interspecific transfer of information plausible. For example, it is possible that dogs pick up on the tone of loud vocalisations from us, allowing them to discriminate between types of loud vocalisations, such as those that accompany human anger. Handlers may also rely on auditory cues from their dogs. In a study of Hungarian herding dogs (Mudis), listeners, regardless of their experience with dogs, were able to categorise bark situations in a way that differed significantly from that expected by chance alone (Pongrácz et al. 2005). Associations were strong for particular bark samples correlated with peak and fundamental frequency and inter-bark intervals.

Relationships between dogs and their handlers

A focus on mechanisms that work in dog training is useful but may obscure the importance of the relationships between dogs and their handlers. This possibility has been studied in military working dog (MWD) contexts. Lefebvre et al. (2007) found that the more attention the dog received from the handler, even if much of this was passive and simply a result of living and interacting with the handler's family, the better its performance and the relationship between dogs and handlers. Essentially, the more sociable dogs had better obedience performance than did less sociable dogs. Dogs that spent more time with handlers also exhibited fewer of the stress-related behaviours that have been used as

indicators of welfare concerns in kennelled dogs, including pacing, barking and destruction (Beerda et al. 1999; Marston et al. 2004).

Horváth et al. (2008) studied responses to play sessions between working dogs and their handlers and concluded that behaviours associated with control, authority or aggression increased cortisol concentrations, while play and affiliative behaviour decreased them. There is evidence that cortisol can act as a hormone-response element and by doing so can stop the transcription of new proteins necessary to make associative memory, an essential step in learning (Truss & Beato 1993). The finding that handler behaviour can be associated with an increase in cortisol concentrations has profound implications for working dogs.

Performance of Dutch police dogs trained with and without shock has been compared (Schilder & van der Borg 2004). All dogs in both groups were successful police dogs, but those in the unshocked group seemed to have a smoother, more integrated relationship with their handlers, based on their response to their handlers' signals.

Positive and statistically significant associations between obedience and the dog–handler relationship have been found (Lefebvre et al. 2007). Handlers who interacted with their dogs in a wider social context (e.g., took their MWD home or practised sports with their dogs) reported more obedience and fewer bites from their dogs. The same dogs also showed fewer behaviours associated with impaired welfare (pacing, barking, destroying items/materials), indicating that the effects of housing at a handler's home and practising sport were strongly linked to an enhanced dog–handler relationship.

Haverbeke et al. (2010) used the Human Familiarisation and Training Programme (HFTP) to teach humans to understand normal canine signalling and to reward playful and appropriate behaviours. When compared with a control group of dogs not participating in HFTP, the HFTP dogs carried themselves higher, with less lowering of body postures associated with fear, showed less

yawning, often a sign of uncertainty, and exhibited fewer aggressive behaviours. These authors concluded that because of the changes in fearfulness, the welfare of HFTP dogs had improved.

The way forward: measuring dog-dog interactions and human-dog interactions

The social relationship between dogs and humans has been a topic of great interest in both the popular literature (e.g. Serpell 1995; Rogerson 2008) and, more recently, scientific literature (e.g. Miklosi et al. 2004; Steinker 2007; Bradshaw et al. 2009). A social relationship may be defined as regular and predictable behaviour occurring between two or more individuals (Scott & Fuller 1965). The two species interact behaviourally (McConnell 2002) and physiologically (Odendaal & Meintjes 2003), but empirical studies of these interactions are only just emerging, despite their profound implications for the success of individual relationships and the way in which lay people are educated to manage and train their dogs. Getting this right can mean the difference between success and failure in the human-dog interface. Rooney et al. (2000) showed how intraspecific play styles of individual dogs were mirrored in those dogs' play styles with humans. The complexity of such human-animal interactions is illustrated by recent studies of the temporal patterning of human-dog dyadic interactions (Kerepesi et al. 2005). In a similar vein, Jones and Josephs (Jones & Josephs 2006) reported associations between salivary hormone concentrations in male dog handlers and their dogs. Specifically, dogs handled by men who underwent greater decreases in testosterone concentration after losing a dog agility competition showed greater increases in cortisol concentrations than in winning teams (Jones & Josephs 2006).

While defining social relationships as regular and predictable behaviour occurring between two or more individuals, Scott and Fuller (1965) also noted that they are neither invariable nor incapable of change. While we agree with this assessment of the fluid nature of the dog-human relationship (changing with factors such as ontogeny, context, etc), we propose that quantifying certain

features of the dog–human interaction may provide further insights that increase our understanding of why some dog–human relationships are successful and others are not. Management factors have a significant impact on the success rate of dogs learning particular tasks (Batt et al. 2010) and in facilitating harmonious coexistence (McGreevy & Masters 2008). For example, the way that a particular tool, such as a lead, is used to train a dog to walk next to a handler may provide insights into the handler’s ability to communicate effectively with the dog. In this context, “communicate effectively” is meant to refer to the handler’s ability to train the dog to do the desired task. For example, a dog can be trained to maintain a consistent position relative to the handler when walking on the lead by strategically releasing the lead pressure when the dog is in the correct position. It may also reflect subtle examples of best practice in the way handler posture changes during heelwork (McGreevy 2009).

So, here we see some exciting parallels between the science of dog training and equitation science – the science of horse riding and training (McGreevy 2007b). Capturing, defining and measuring the qualities of techniques used by the very best dog handlers are the essence of this approach. It seems that, despite the importance of on- and off-lead heelwork in the eyes of seasoned trainers, many owners use the lead simply to restrain the dog and many dogs use the lead to control their owners. That said, we should not ignore this critical interface. Even outside formal training, the average pet dog spends at least some time on the lead. Such periods are likely to be of enormous relevance to the dog since they represent time spent one-on-one with its humans and the end-point (such as arrival at an exercise venue) is often highly reinforcing. In equitation science, rein tension meters are an established means of measuring the mechanisms horse riders use to train horses with negative reinforcement (NR) (i.e., the horse is rewarded by the rider immediately releasing the tension in the rein when a horse performs the desired behaviour). Using the same approach, a lead tension meter could be used to record the general level of contact, the intensity and frequency of all corrections a handler applies via the lead, and the dog’s latency to respond to them. Such data would capture the effectiveness with which the

handler uses NR or punishment and the extent to which the dog has become habituated to aversive stimuli from the collar.

Considering principles beyond negative reinforcement, equitation science shows how operant conditioning of pressure cues can lay the foundation for the emergence of classical conditioned cues such as those from the rider's seat or, most relevant here, the handler's posture. It explains how even without leading a horse or applying physical pressure, hands-off round pen techniques are effective in training horses. As such, it identifies some fascinating commonalities with the use of body language by dog trainers. The playbow and the body block (McConnell 2002) are examples of postural techniques that seasoned dogfolk use, often without being aware of what they are doing. We can use kinematic analysis systems that are emerging from equitation science to study these techniques.

Equitation science has identified the need for a working horse ethogram (Heleski et al. 2009). By the same token, canine scientists need a validated canid intraspecific social ethogram that exhaustively lists the types of behaviour performed by domestic dogs in a social context (Plowman 2010). It is accepted that many research groups have developed their own ethograms but recent meetings of canine scientists (such as the 1st and 2nd Canine Science Forum in 2008 and 2010, respectively) serve to emphasise the need for a canine ethogram that is validated to withstand use by multiple observers and different laboratories around the world. Lack of standardisation will continue to suppress the development of clear communication among groups and obstruct attempts at meta-analysis (Tomkins et al. 2010). A validated ethogram will pave the way for the development of a related and cross-referenced dog-human ethogram. This tool is of critical importance because with it canine scientists can advise veterinarians, handlers, trainers and owners on the relative importance of subtle behavioural mechanisms operating at the dog-human interface. Only then will we truly decipher the role, if any, of perceived social status in our dogs' responses.

Conclusions

It is critical that we study the way in which harmony is achieved among dogs and the extent to which communication between dogs and humans can align with or breach the framework offered by the dog–dog social ethogram. Aspects of our body language and behaviour may stimulate resource-guarding and forms of anxiety in dogs. Displacing dogs that have learned to defend their resources may culminate in a bite. It is critical that we fully explore possible mechanisms beyond a learning-theory framework that may explain dog–human aggression and that the emerging science of dog training continues to embrace principles derived from both psychology and ethology.

Acknowledgments

The authors are grateful to Dr Wendy Birkhead for enlightening discussions on the problems anthropologists have faced when grappling with the concept of “family”. Two anonymous reviewers provided excellent feedback on earlier drafts of this article.

Author Contributions

The following two chapters (Chapter 3 and Chapter 4) include original papers published by the peer-reviewed journals “Behavioural Processes” and “The Veterinary Journal” respectively. The ideas, development, data collection, analysis and preparation of the manuscript were all the primary responsibility of the candidate, working within the Faculty of Veterinary Science under the supervision of Prof. Paul McGreevy (primary supervisor) and, Dr Nicholas Branson (associate supervisor). Prof. McGreevy and Dr Branson both assisted in the development of the study in their roles as supervisors. Assoc. Prof. Peter Thomson assisted in data analysis and in preparing the relevant sections of the manuscript.

The inclusion of co-authors reflects the fact that the work came from an active collaboration between researchers and acknowledges input into team-based research.

Confirmation of Co-Authorship of Published Work

I, *Melissa Starling*, contributed to the organisation, project design, data collection, statistical data analysis and preparation of the manuscripts entitled **“*Boldness in the dog differs among breeds and breed groups*”** and **“*Age, sex and reproductive status affect boldness in domestic dogs*”**.



Melissa Starling _____ Date 1.8.2013

I, as a Co-Author, endorse that this level of contribution by myself and the candidate indicated above is appropriate.



Prof. Paul McGreevy _____ Date 25.7.2013



Dr Nicholas Branson _____ Date 31.7.2013

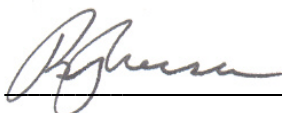

A/Prof. Peter Thomson _____ Date 4 July 2013

3 “Boldness” in the domestic dog differs among breeds and breed groups

Melissa J. Starling^a, Nicholas Branson^b, Peter C. Thomson^a, Paul D. McGreevy^a

^a Faculty of Veterinary Science, University of Sydney, NSW, Australia

^b Deakin Research, Deakin University, VIC, Australia

This paper is published in *Behavioural Processes*, 2013, 97, 53-62.

Abstract

“Boldness” in dogs is believed to be one end of the shy-bold axis, representing a super-trait. Several personality traits fall under the influence of this super-trait. Previous studies on boldness in dogs have found differences among breeds, but grouping breeds on the basis of behavioural similarities has been elusive. This study investigated differences in the expression of boldness among dog breeds, kennel club breed groups, and sub-groups of kennel club breed groups by way of a survey on dog personality circulated among Australian dog-training clubs and internet forums and lists. Breed had a significant effect on boldness ($F=1.63$, $\text{numDF}=111$, $\text{denDF}=272$, $p<0.001$), as did breed group ($F=10.66$, $\text{numDF}=8$, $\text{denDF}=772$, $p<0.001$). Herding and gundog groups were broken into sub-groups based on historic breed purpose. Retrievers were significantly bolder than flushing and pointing breeds (Reg. Coef.=2.148; S.E.=0.593; $p<0.001$), and tending and loose-eyed herding breeds were bolder than heading and cattle-herding breeds (Reg. Coef.=1.744; S.E.=0.866; $p=0.045$ and Reg. Coef.=1.842; S.E.=0.693; $p=0.0084$ respectively). This study supports the existence of the shy-bold continuum in dogs. Differences in boldness among groups and sub-groups suggest that behavioural tendencies may be influenced by historical purpose regardless of whether that purpose still factors in selective breeding.

Introduction

The study of personality may offer a framework to explain some of the variation in animal behaviour. Understanding behavioural variability in animals may improve our ability to predict how individuals are likely to behave (Svartberg 2003), and such information can be used to modify the way particular animals are managed and trained. In addition, it may help to identify work that best suits an individual's strengths and weaknesses. Fine-tuning the way we interact with and keep animals at the individual level has the potential to improve animal welfare and improve human–animal interactions.

The domestic dog (*Canis lupus familiaris*) is a subspecies of the wolf (*Canis lupus*), yet its morphology and behaviour differ vastly, both from the ancestral form and among breeds, reflecting the many and varied uses it has been selectively bred for over millennia. Dogs live in close proximity to humans across the Western world, and while it is thought there are substantial benefits to dog ownership (see Barker & Wolen 2008 for review), there is also a darker side to our relationship with this species. For example, every year, we destroy a significant percentage of the domestic dog population because we find its behaviour unacceptable (McGreevy & Bennett 2010). Studies of personality in dogs may help to predict troublesome behaviour and help owners manage it. They may also aid in selecting dogs of sound temperament to breed from, and optimise matching new owners with individual dogs. Conversely, some personalities may be more difficult for companion-dog owners to manage than others. For example, there is thought to be a genetic component to problems such as pathological anxiety in dogs (Ohl et al. 2008). Here we consider the influence of coping styles on behaviour, the personality of dogs in the broadest sense of super-traits and then, in more detail, specific behaviours and personality traits.

Previous studies of dog personalities have focused on identifying personality traits (Draper 1995; Cattell & Korth 1973; Gosling et al. 2003; Ley et al. 2008;

Svartberg & Forkman 2002). Some of the traits identified in dog personality studies so far may be analogous to one another but labelled differently, for example, “training focus” (Ley et al. 2008) and “trainability-openness” (Draper 1995). The absence of clearly defined categories in this field limits our ability to compare the results of different dog personality studies (Gosling 2001). Table 3.1 shows how dog personality traits found in previous studies relate to the “Big Five” suite of traits identified by Ley et al. (2008), who surveyed owners’ descriptions of their dogs and identified key adjectives using inter-rater testing. Many of the tabulated traits in Table 3.1 were also identified through surveys of dog owners. Inter-rater testing is one method to test the reliability of survey data, offering a measure of how consistently individual observers describe the same individual (Sinn et al. 2010b). Previous studies suggest inter-rater agreement varies with the trait in question (Ley et al. 2009; Goddard & Beilharz 1986). This potential difficulty also manifests in test-retest reliability procedures, where it is assumed that personality traits are stable over time, but this may depend on the trait in question. High test-retest reliability has been reported for traits related to sociability, extraversion, neuroticism and curiosity (Svartberg 2005; Ley et al. 2009). Whether surveys describe a prevailing human belief about dog personality traits, or the dog personality traits themselves, is best explored through the addition of behavioural observations. Similarly, between-study bias can be minimised by comparing survey responses with validated behavioural observations. For example, Svartberg and Forkman (2002) compared scores from survey questions from the Canine Behaviour and Research Questionnaire (C-BARQ) (Hsu & Serpell 2003) with behavioural observations from the Swedish Working Dog Club’s “Dog Mentality Assessment” (DMA). Survey respondents were not aware of the comparison between survey responses and the DMA. This exercise validated the DMA for predicting everyday behaviour.

| “Big Five” traits for dogs | Description | Similar traits in dog literature | Human “Big Five” possible analogue |
|-----------------------------------|---|---|---|
| Extraversion ^{a,e} | Excitability and high physical activity | Reactivity-surgency ^d ; Lively temperament ^c ; Playfulness ^b | Extraversion |
| Neuroticism ^a | Nervous sensitivity and | Apprehension ^e | Neuroticism |

| | | | |
|--|--|--|------------------------|
| Neuroticism ^a | Nervous sensitivity and cautious and avoidance behaviour | Apprehension ^e | Neuroticism |
| Self-assuredness/motivation ^a | High degree of positive internal motivation of a dog | Curiosity/fearlessness ^b ; Self-sufficiency ^e ; Investigation ^d | Openness to experience |
| Training focus ^a | High trainability | Trainability-openness ^d ; Trainability-focus; Responsiveness to handling ^e | Conscientiousness |
| Amicability ^a | Agreeableness, sociability and | Sociability ^b | Agreeableness |

Table 3.1. Personality traits for dogs identified by Ley et al. (2008) and possible analogues from other dog personality studies. ^a = (Ley et al. 2008); ^b = Svartberg and Forkman, 2002; ^c = (Wilsson & P. Sundgren 1997); ^d = (Draper 1995); ^e = (Cattell & Korth 1973). The possible analogue from the human “Big Five” personality traits is suggested by the authors based on common language and words used between explicit descriptions of the traits.

“Super-trait” is a term that has been used in human and animal personality literature to identify higher-order personality traits that represent major axes of variation (Krueger et al. 2001; Zuckerman 1994; Svartberg 2005). One such axis referred to in the dog personality literature is the shy-bold axis (Svartberg & Forkman 2002; Svartberg 2002). A similar axis identified in the dog literature is referred to as coping styles (Blackwell et al. 2010; Horváth et al. 2007). Both terms refer to a possible behaviour syndrome, defined as a suite of behaviours that tend to co-occur (Wilson et al. 1994). The shy-bold axis has been described in many species, from fish (Harcourt et al. 2010) to humans (Wilson et al. 1994), whereas coping styles are discussed in laboratory rodent literature (Koolhaas 2008; Koolhaas et al. 1999; Koolhaas et al. 2010; Coppens & de Boer 2010). It is uncertain how stable either trait is, or whether they are related.

The shy-bold axis in dogs is assumed to be an inherent personality trait, as supported by consistent re-test behavioural results over a short period (2-3 months) (Svartberg & Forkman 2002) and consistent survey results over a longer period (1-2 years) (Svartberg 2005). These serial studies over time identified traits related to boldness, including curiosity, fearlessness, playfulness, distance playfulness, chase-proneness and sociability (Svartberg & Forkman 2002). These traits were grouped into broader personality factors under the influence of the shy-bold axis. These factors were “playfulness”, “curiosity/fearlessness”, and “sociability” (Svartberg 2005). Later work

suggested that survey responses identified five correlations with boldness, including positive correlations with “human-directed play interest”, “stranger-directed interest”, and “trainability”, and negative correlations with “stranger-directed fear” and “non-social fear”.

Coping styles are defined as a coherent set of behavioural and physiological responses to stress that are consistent over time and characteristic of a certain group of individuals (Koolhaas et al. 1999). Animals with proactive coping styles tend to have a high level of aggression, short attack latency, and engage in active attempts to cope with a stressful stimulus (Koolhaas et al. 1999). A proactive coping style is characterised by persistence (Coppens & de Boer 2010), impulsivity and routine-driven behaviour that reflects previous experiences rather than current environmental cues (Cervantes & Delville 2007) and is considered inflexible (Coppens & de Boer 2010). In contrast, a reactive coping style is characterised by low levels of aggression, long attack latency, and behaviour reactions from environmental cues (Koolhaas et al. 1999). The behaviour of these individuals is considered flexible, but tends to include more avoidance behaviour than attack behaviour (Coppens & de Boer 2010). There are also physiological responses characteristic of one coping style or the other, such as a higher baseline and hypothalamic-pituitary-adrenal (HPA)-axis reactivity and parasympathetic reactivity in reactive individuals, and higher sympathetic reactivity and lower HPA-axis reactivity in proactive animals (Koolhaas et al. 2010).

It has been suggested that boldness and shyness or proactive and reactive coping styles are a measure of behavioural syndromes only but that neither account for the emotional intensity of the behaviour (Coppens & de Boer 2010). Some authors question the accuracy of assigning a large number of behavioural tendencies to just one factor: the shy-bold axis. Sheppard and Mills (2002) argue that assigning behavioural tendencies to this single axis is not consistent with the proposed biological basis of those behaviours and instead propose two scales that they label positive activation and negative activation. The positive-

activation scale is characterised by energised, excitable and persistent behaviour associated with reinforcing experiences, whereas the negative-activation scale encompassed more inactive behaviours and avoidance behaviours associated with negative experiences (Sheppard & Mills 2002). In contrast, the shy-bold continuum and coping styles do not consider emotional states and Sheppard and Mills (2002) suggest that the shy-bold axis probably consists of both positive and negative activation elements. A third coping style – ambivalence – has been described only in dogs, and is characterised by high physical activity and higher levels of cortisol in response to stressors than the levels found in proactive or reactive animals (Horváth et al. 2007). However, this group may represent animals that did not have an ethologically relevant solution to the test conditions, or possibly a transition between a proactive and reactive coping strategy that may reflect past experiences or age (Horváth et al. 2007). Blackwell et al. (2010) suggest that in shelter dogs a proactive coping style is characterised by high HPA-axis activation and heightened ability to rapidly learn a new task, compared to a reactive coping style characterised by fearful behaviour and an impaired ability to learn a new task. Dogs were also differentially affected by being housed in a shelter environment, depending on their coping style, with behavioural signs of stress such as inactivity and avoidance of interactions being associated with an impaired ability to learn a simple shaping task, possibly reflecting a reactive coping style. Dogs with higher HPA-axis activation displayed an enhanced ability to learn the same task, possibly indicating a more proactive coping style (Blackwell et al. 2010). However, one of the factors confounding these conclusions is lack of a clear association between behavioural stress indicators and HPA-axis activation (Beerda et al. 2000; Beerda et al. 1997).

There is evidence to suggest that dog behaviour differs among breeds (Svartberg 2006b; Turcsán et al. 2011; Bradshaw et al. 1996). The large number of breeds and breed mixes makes studying breed-typical behaviour difficult for all but the most common breeds. Pooling breeds into breed groups may be preferable to investigating breeds themselves, and may provide useful information on the origin of variation in dog behaviour. National kennel clubs have clustered breeds

according to similarities in morphology and anecdotal information about the development of breeds for specific purposes (Turcsán et al. 2011), but breed folklore is problematic for at least two reasons. First, the origins of breeds and their development are rarely well documented, are often steeped in oral tradition and usually lack verifiable references. Second, breed folklore may encourage breed stereotypes, with owners showing a confirmation bias as they report the behaviours they expect to see in their dogs, which in turn may perpetuate the breed stereotype (Turcsán et al. 2011). In addition, groups such as “utility” may simply reflect a catch-all pool for breeds that do not fit well into better-defined groups. Further confounding the problem is the shift from breeding dogs for a specific purpose to breeding dogs primarily as companions (McGreevy & Nicholas 1999) and show dogs (Svartberg 2006b). Attempts to find similarities within breed groups have met with mixed success with results suggesting that kennel club breed groups do not necessarily cluster breed types with similar behaviour (Svartberg 2006a; Turcsán et al. 2011; Bradshaw et al. 1996). Nevertheless, there may be more to breed groups than has been considered thus far in the scientific literature. The diversity in dog behaviour within and among breeds and breed groups might suggest that traditional kennel club groups are simply not categorised at a fine enough level of detail to produce consistent results at group level. For example, within the herding breeds, there are sheep-herding and cattle-herding breeds (Morris 2001). Within the gundog group, there are flushing breeds, pointing breeds, and retrieving breeds (Schmutz & Schmutz 1998). Before dismissing breed folklore as largely irrelevant, it behoves us to examine the more elusive details. This paper uses behavioural questionnaires to study differences and similarities in breed-group behaviour at a finer level of detail than has been used in previously reported studies, including studies examining the genetic relationships among dog breeds (e.g. Vilà et al. 1997; Lindblad-Toh et al. 2005).

For a personality or behaviour test to be useful to dog owners or trainers, it should be predictive of future behaviour (Sinn et al. 2010a; Svartberg 2005). To move beyond identifying personality traits and determine what these traits

mean to training, management, and predicting behaviour, it is necessary that labels for commonly found traits are agreed upon. One group that has been proactive in driving this approach is the Scientific Working Group on Dog and Orthogonal detector Guidelines (see <http://www.swgdog.org/>). This study aims to build on existing knowledge of dog personality traits and the shy-bold axis super-trait by examining the expression of boldness in a wide range of breeds. It looks for evidence that the shy-bold continuum and coping styles are related and factors that may affect the expression of boldness. Terminology used in this article is aligned with that used by Svartberg (2002; 2005).

Materials and methods

Item generation

A survey was developed for dog owners to report on the personality of their dogs. Survey items were drawn from the Canine Behavioural Assessment and Research Questionnaire (CBARQ) (Hsu & Serpell 2003) and guided by Svartberg's previous work on boldness in dogs (Svartberg 2002; Svartberg 2005). CBARQ has been validated by correlating survey answers with professional diagnoses of behavioural problems (Hsu & Serpell 2003). For the current questionnaire, items from CBARQ that may be associated with boldness or shyness and indicated by everyday dog behaviour were retained, with the exception of stranger-directed aggression. This factor has been shown to have a low loading on the component associated with boldness and was not strongly associated with aggressiveness in everyday life (Svartberg 2005). It is likely that aggressiveness as a trait is unrelated to the shy-bold axis (Svartberg 2005; Scott & Fuller 1965). Items not found to be associated with boldness and shyness were also excluded to reduce the time required of respondents and to focus on items that were likely to be predictive of future behavioural tendencies. In addition, because Svartberg (2002; 2005) showed that separation-related behaviour, predatory behaviour, owner-directed aggression, and dog-directed behaviour in the home environment had no correlation with the Swedish Working Dog Club's

“Dog Mentality Assessment” (DMA) personality traits, and to that extent were not validated, these items were also excluded.

Additional items covering play behaviour as developed by Svartberg (2002; 2005) were included in our questionnaire. It used two forms of 5-point rating scales, with different sections using either of those forms. One was a semantic differential-type rating scale as used by Hsu and Serpell (2003) and the other used a selection of graded options (“never”, “seldom”, “sometimes”, “usually” and “always”) that referred to the frequency of the behaviour in the recent past. A further section exploring proactive and reactive behaviour was added to the survey. It included questions developed from reviews of the characteristics of proactive and reactive coping styles (Coppens & de Boer 2010; Koolhaas et al. 1999; Koolhaas et al. 2010). These questions used the semantic differential-type 5-point rating scale on which respondents were asked to rate the intensity of their dog’s behaviour ranging from 0, where the behaviour was not observed, to 4, where the behaviour was extreme.

Participants

The survey was circulated via Australian internet forums and e-mail lists with a subject focus of domestic dogs. Respondents were sought exclusively from Australia to avoid international demographic variables being introduced into the results. Respondents were over 18 and under 80 years of age and were asked to report on a dog they lived with. They were allowed to complete additional surveys for additional dogs if they lived with more than one.

Statistical analysis

Statistical analyses were carried out with the program R (R Development Core Team, 2011). Mean substitution was used for missing data as per Svartberg (2002; 2005), and surveys with more than five missing responses were discarded. A principal components analysis (PCA) was run on the results from the survey. The number of components extracted was determined by the scree plot method.

The first principal component scores extracted from the PCA was subjected to further analysis using linear and linear mixed models using the “lm” and “lme” function from the nlme package in R. Terms were first tested for significance using the t-test or “anova” function in R and, if they were significant, added to a linear model. The terms in the models were tested using the “anova” function, comparing the linear model containing the new term with a linear model excluding the new term. The Akaike Information Criterion (AIC) value was also used to assess the model of best fit. Breed was considered a random effect nested within the fixed effect United Kennel Club (UKC) Breed Group, called “UKC.Breed.Group”. UKC breed groups are closest to the international convention adopted by Fédération Cynologique Internationale (FCI), but use fewer groups. The reduced breed groups better suited the smaller number of breeds in the current study’s data. The linear mixed model was then compared to the linear model containing all significant fixed-effect factors using a likelihood ratio test using the “anova” function in R. Dogs of mixed breed heritage were assigned to a breed group called “Mixed” if their breed composition was unknown or only one parent was known. Where all breeds listed in the makeup of a mixed breed individual belonged to the same UKC group, that dog was categorised as also belonging to that UKC group. Otherwise the individual was categorised as “Mixed”.

The herding and gundog breed groups were subjected to further analysis to investigate whether different classes of herding or gundog breeds differed significantly from one another. Only these groups were subjected to this further analysis because they were the only groups with sufficient numbers that contained an easily categorised variety of breeds. Breeds in the herding group were categorised according to their herding style, as different herding breeds have been selected for specific behaviour patterns towards specific livestock (Coppinger & Schneider 1995). Cattle-herding breeds (such as Australian cattle dogs and corgis) were categorised as “heelers” (Coppinger & Schneider 1995); herding breeds that work from a distance with a low stance and hard eye (e.g. Border collies and Kelpies) were categorised as “headers”; breeds that work closer with a more upright stance and loose eye (e.g. collies and Australian

shepherds) were categorised as “loose”; and breeds originally developed to be more protective and simply keep the livestock from straying (such as the German shepherd dog) were categorised as “tending”. The gundog group was also broken into four categories: “flushing”, including spaniels and setters; “retrievers”; “pointers”; and “HPR”, including breeds developed to hunt, point and retrieve (e.g. the German shorthaired pointer, Hungarian vizsla and Brittany). A linear model was constructed to compare boldness scores among the different herding sub-groups and another for gundog sub-groups.

A ‘size’ factor was also considered. Size of dogs was not collected in the survey itself, but purebreds were categorised as small, medium, large or giant according to data on preferred height as specified in the breed standards within the Australian National Kennel Club (ANKC). In this case, ANKC information was considered most relevant as it was assumed most pedigree dogs in Australia were bred according to ANKC standards. Mixed breed dogs were excluded from this analysis.

Results

Principal Components Analysis (PCA)

The survey generated 1054 responses that could be used. The PCA produced one major component that accounted for 21.4% of the variation. This was the sole component retained as there was a clear division in the scree plot between this component and the next one (Fig. 3.1). Furthermore, there were no patterns in the items featuring high positive or high negative loadings in subsequent components to suggest that they represented a component of interest. The retained component was characterised by high loadings on factors relating to play and sociality and negative loadings on avoidance and other behaviours indicating fear. Table 3.2 shows PCA loadings above 0.1 and below -0.1 for the first component in this study.

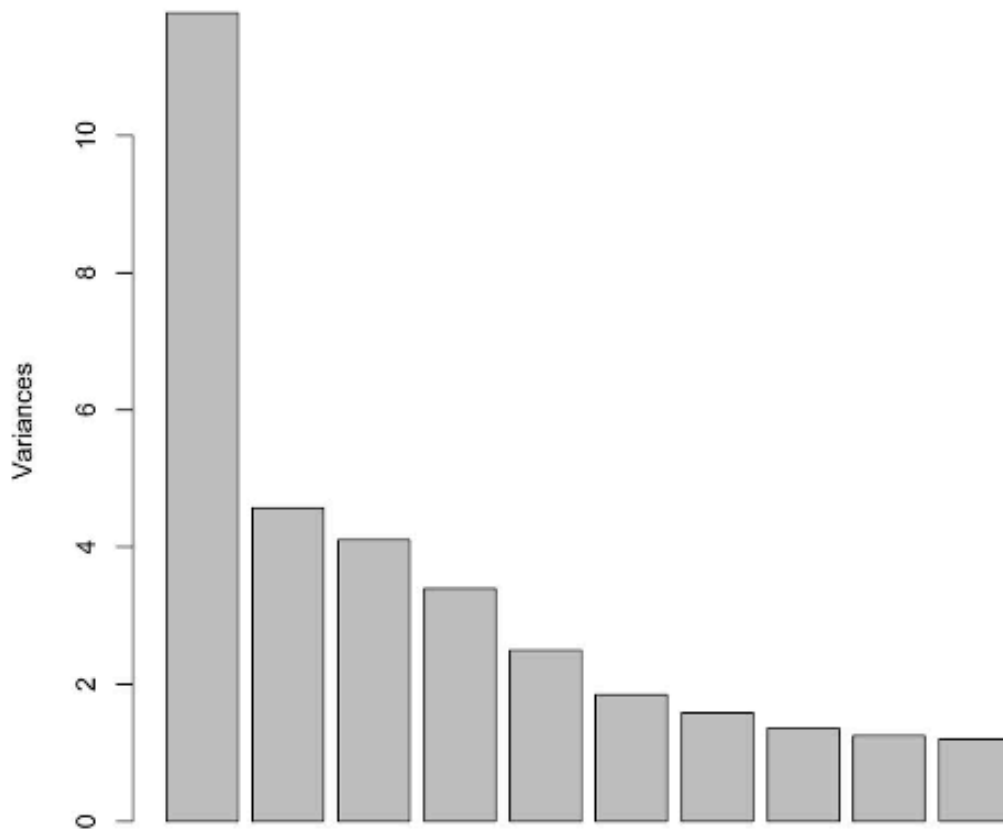

Fig. 3.1 Scree plot of Principle Components Analysis showing variances of the first ten components extracted. Only the first component was retained for further analysis. It accounts for 21.4% of the overall variance, but the scree plot clearly shows a large decline in the variance accounted for by components after the first component. The second and third components were examined for inclusion, but did not have strong loadings that suggested a theme.

| Behavioural Factor | Survey Item | Loading on PC1 |
|------------------------------|--|----------------|
| Stranger-directed interest | Approaches unfamiliar children away from home in a friendly manner | 0.210 |
| Stranger-directed interest | Enjoys being petted by unfamiliar people | 0.209 |
| Stranger-directed interest | Approaches unfamiliar adults in a friendly manner away from home | 0.208 |
| Stranger-directed interest | Greets unfamiliar children visiting the home in a friendly way | 0.206 |
| Stranger-directed interest | Greets unfamiliar adults visiting the home in a friendly way | 0.198 |
| Stranger-directed interest | Enjoys interaction with several unfamiliar people at once | 0.194 |
| Human-directed play interest | Willing to play with unfamiliar people | 0.192 |
| Dog-directed interest | Enjoys playing with entire female dogs | 0.181 |
| Dog-directed interest | Enjoys playing with desexed female dogs | 0.179 |

| | | |
|------------------------------|---|--------|
| Dog-directed interest | Enjoys playing with desexed male dogs | 0.176 |
| Dog-directed interest | Quick to respond to other dogs' invitations to play | 0.165 |
| Dog-directed interest | Enjoys playing with entire male dogs | 0.161 |
| Dog-directed interest | Enjoys wrestling with other dogs | 0.156 |
| Human-directed play interest | Eager to play with family | 0.102 |
| Reactivity | Sensitivity to changes in familiar surroundings | -0.106 |
| Non-social fear | Fear of wind | -0.128 |
| Non-social fear | Fear of novel objects | -0.136 |
| Non-social fear | Fear of traffic | -0.148 |
| Non-social fear | Fear of loud noises | -0.150 |
| Non-social fear | Fear in an unfamiliar situation | -0.151 |
| Dog-directed fear | Fear when unfamiliar dog lunges | -0.154 |
| Pain sensitivity | Fear during standard veterinary procedures | -0.156 |
| Dog-directed fear | Fear when approached by small unfamiliar dog | -0.168 |
| Dog-directed fear | Fear when large unfamiliar dog approaches | -0.170 |
| Dog-directed fear | Fear when unfamiliar dog visits home | -0.174 |
| Stranger-directed fear | Fear when unfamiliar person visits house | -0.197 |
| Stranger-directed fear | Fear when approached by unfamiliar child | -0.207 |
| Stranger-directed fear | Fear when touched by unfamiliar person | -0.213 |
| Stranger-directed fear | Fear when approached directly by unfamiliar adult | -0.214 |

Table 3.2. Items from the survey that loaded high or very low on the first principal component (PC1), labelled “boldness”. The sample population was made up of 49% female and 51% male dogs. High loadings indicate items relate to boldness in dogs, where very negative loadings indicate items relate to shyness. The Behavioural Factor, as identified by Hsu and Serpell (2003), is given where items have originated from the C-BARQ questionnaire and Svartberg (Svartberg 2002; Svartberg 2005) where items originated from Svartberg’s additional play questions. Behavioural factors for items not previously used have been assigned behavioural factors by the authors.

Linear mixed model

The model of best fit for the boldness score, as assessed by the first principal component, included five terms: age (in years), gender, reproductive status, breed, and breed group. Age and gender of the owner was not a significant factor, and nor was origin of the dog or age of the dog when acquired, so these terms were not included in the final model. The output of the model of best fit is shown in Table 3.3. Boldness decreased with age, as shown by the negative regression coefficient. Male dogs were bolder than female dogs, and entire dogs of either gender were bolder than desexed dogs of either gender. Age, gender and reproductive status will be discussed in detail in a subsequent paper. Size was also found to be significant ($F=14.89$; $\text{numDF}=3$; $\text{denDF}=100$; $p<0.001$). However, there was a strong association between breed group and size (Fisher exact test, $p<0.001$) that prevented the fit of a model including both terms, breed

group and size. The solution to this was to prepare two linear mixed models, one including breed group but not size and the other including size but not breed group. It is noted that the model including size is technically a different dataset (N=700) to the model excluding it (N=1054), because size categories were only assigned to purebred dogs. Both models are shown aligned in Table 3.3. Boldness decreased across decreasing size categories, but only the small size category differed significantly from the reference group, which was the giant group (Reg. Coef. =-2.726, df=100; S.E.=0.719; p<0.001).

The rest of this report will focus on breed and breed groups. There were 109 UKC-recognised dog breeds in the survey responses and many mixed-breed dogs. Breed had a significant effect on boldness (F=1.63; numDF =111; denDF=272; p<0.001). Table 4 shows the boldness scores for the most common breeds in the survey results with 15 or more responses. Boldness scores were also assessed for each UKC group (Figure 3.2). The Guardian group was the boldest (Reg. Coef.=3.085; S.E.=0.549; p<0.001) and the reference group, the Companion group, the shyest. The Northern and Spitz group (Reg. Coef.=1.68; S.E.=0.657; p=0.011) and the Gundog group (Reg. Coef.=1.958; S.E.=0.477; p<0.001) also scored significantly higher in boldness than other groups. Mixed breeds (Reg. Coef.=1.144; S.E.=0.391; p=0.004) fell on the shy end of the shy-bold axis. Moderately bold breed groups were the herding group (Reg. Coef.=1.592; S.E.=0.453; p<0.001) and Terrier group (Reg. Coef.=1.410; S.E.=0.551; p=0.011). The Sighthound and Pariah Dog, and Scenthound groups did not differ significantly in boldness from the reference group (Companion) (Reg. Coef.=1.085; S.E.=0.671; p=0.107 and Reg. Coef.=0.591; S.E.=0.894; p=0.509, respectively).

| Effect | Model 1 | | | | Model 2 | | | |
|---|------------|-------|-----|---------|-----------|---------|-----|---------|
| | Reg. Coef. | S.E | DF | p-value | Reg.Coef. | S.E | DF | p-value |
| (Intercept Model 1) Companion (n=151), female (n=507), neutered (n=840) (Intercept Model 2) Giant (n=31), female (n=354), neutered (n=515) | 1.075 | 0.365 | 777 | 0.003 | 1.767 | 13.0667 | 593 | 0.008 |
| Gender male (n=547; n=346)*** | 0.776 | 0.197 | 777 | <0.001 | 0.663 | 0.227 | 593 | 0.004 |
| Entire (n=214; n=185)* | 0.570 | 0.262 | 777 | 0.023 | 0.627 | 0.273 | 593 | 0.022 |
| Age in years (n=1054; n=700)*** | -0.170 | 0.026 | 777 | <0.001 | -0.159 | 0.031 | 593 | <0.001 |
| Guardian (n=82)*** | 3.084 | 0.549 | 265 | <0.001 | NA | NA | NA | NA |
| Gundog (n=162)*** | 1.958 | 0.477 | 265 | <0.001 | NA | NA | NA | NA |
| Herding (n=228)*** | 1.592 | 0.453 | 777 | <0.001 | NA | NA | NA | NA |
| Mixed (n=234)** | 1.144 | 0.391 | 777 | 0.004 | NA | NA | NA | NA |
| Terrier (n=80)* | 1.410 | 0.551 | 777 | 0.011 | NA | NA | NA | NA |
| Northern (n=47)* | 1.680 | 0.657 | 265 | 0.011 | NA | NA | NA | NA |
| Scenthound (n=20) | 0.591 | 0.894 | 265 | 0.509 | NA | NA | NA | NA |
| Sighthound (n=50) | 1.085 | 0.671 | 265 | 0.107 | NA | NA | NA | NA |
| Size small (n=119)*** | NA | NA | NA | NA | -2.726 | 0.719 | 100 | <0.001 |
| Medium (n=274) | NA | NA | NA | NA | -1.191 | 0.683 | 100 | 0.084 |
| Large (n=276) | NA | NA | NA | NA | -0.534 | 0.687 | 100 | 0.439 |

Table 3.3 Statistical output of the fixed effects from the final linear mixed model accepted, including dog gender, reproductive status, age, breed, size and breed group. Two models are presented as high correlation between breed group and size made fitting a model including both terms problematic. Model 1 includes breed group but excludes size and is the full dataset. Model 2 excludes breed group and includes size, but is a reduced dataset, including only purebred dogs with height information in their breed standard. All terms in this linear mixed model had a significant effect on boldness. Terms included in both models have n reported first for Model 1 followed by n for Model 2. Significance is in comparison with to the reference level, which in Model 1 is companion breed, female, and neutered, and for Model 2 is giant, female, and neutered. ‘*’ Denotes a significance level of <0.05, ‘*’ a significance level of <0.005, and ‘****’ a significance level of <0.001.**

| Breed | Boldness score |
|--------------------------------------|----------------|
| Staffordshire bull terrier (n=22) | 1.33 |
| Labrador retriever (n=54) | 0.98 |
| German shepherd dog (n=41) | 0.95 |
| Golden retriever (n=24) | 0.67 |
| Border collie (n=71) | 0.17 |
| Kelpie (n=22) | 0.04 |
| Boxer (n=17) | 0.04 |
| Hungarian vizsla (n=17) | 0.02 |
| Cavalier King Charles spaniel (n=16) | 0.00 |
| Greyhound (n=23) | -0.18 |
| Jack Russell terrier (n=16) | -0.63 |
| Australian cattle dog (n=17) | -0.67 |

Table 3.4 Boldness scores for breeds with 15 or more respondents. Boldness scores here represent random effects estimates, also called conditional modes or means, from the final linear mixed model. In this model boldness is a component extracted from a principal components analysis (PCA) and is considered the dependent variable. It is characterised by a willingness to play and be approached and has negative loadings for avoidance behaviour and behavioural indicators of fear. Only the random effects estimate (Boldness score) has been reported because the distribution of random effects is unknown.

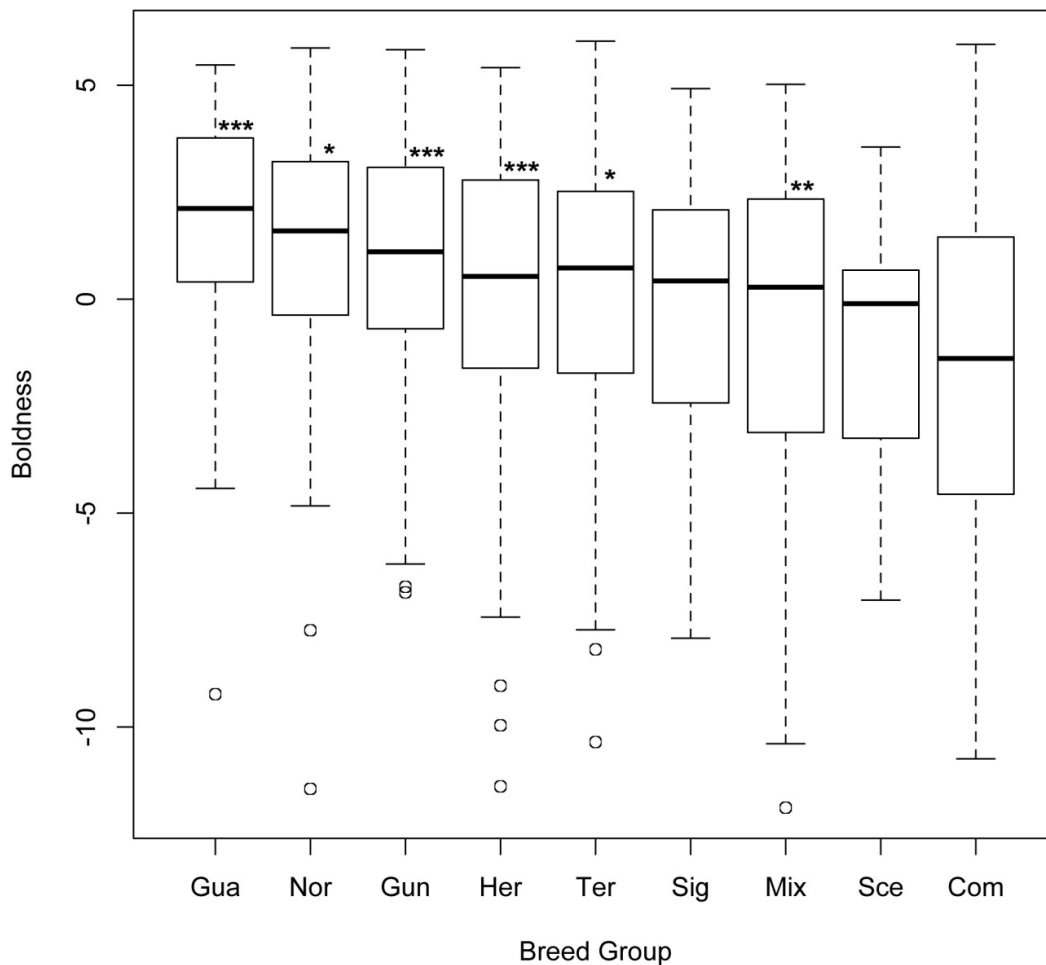

Figure. 3.2. Mean Boldness scores for UKC breed groups with error bars. Gua=Guardian group, Nor=Northern and Spitz, Gun=Gundog, Her=Herding, Ter=Terrier, Sig=Sighthound, Mix=Mixed breed, Sce=Scenthound, Com=Companion. Groups significantly bolder than the reference group (Companion) are marked with an asterisk: '*' denotes a significance level of <0.05, '' a significance level of <0.005, and '***' a significance level of <0.001. The statistical model used was the 'lm' and 'lme' function in the statistical package R, and models were tested using the ANOVA function in R and the AIC value.**

Within breed group analysis

The herding and gundog breed groups were subjected to further analysis to investigate whether different classes of herding or gundog breeds differed significantly from one another. Within the herding group, purpose had a significant effect on boldness scores ($F=2.957$; numDF=3; denDF=224; $p=0.033$), with tending breeds being the boldest, then loose-eyed herding breeds, hard-eyed herding breeds and cattle-herding breeds being the shyest group (Figure 3.3). Only the loose-eyed and tending breeds differed significantly in boldness from other herding sub-groups (Reg. Coef. =1.744; S.E.=0.866; $p=0.045$ and Reg. Coef. =1.842; S.E.=0.693; $p=0.0084$ respectively). Purpose was also a significant effect on boldness in the gundog group ($F=5.692$; numDF=3; denDF =158; $p=0.001$). Retrievers were the boldest, followed by pointers, HPR, and flushing breeds were the shyest (Figure 3.4). Only the retrievers differed significantly from other gundog sub-groups in boldness (Reg. Coef. =2.148; S.E.=0.593; $p<0.002$).

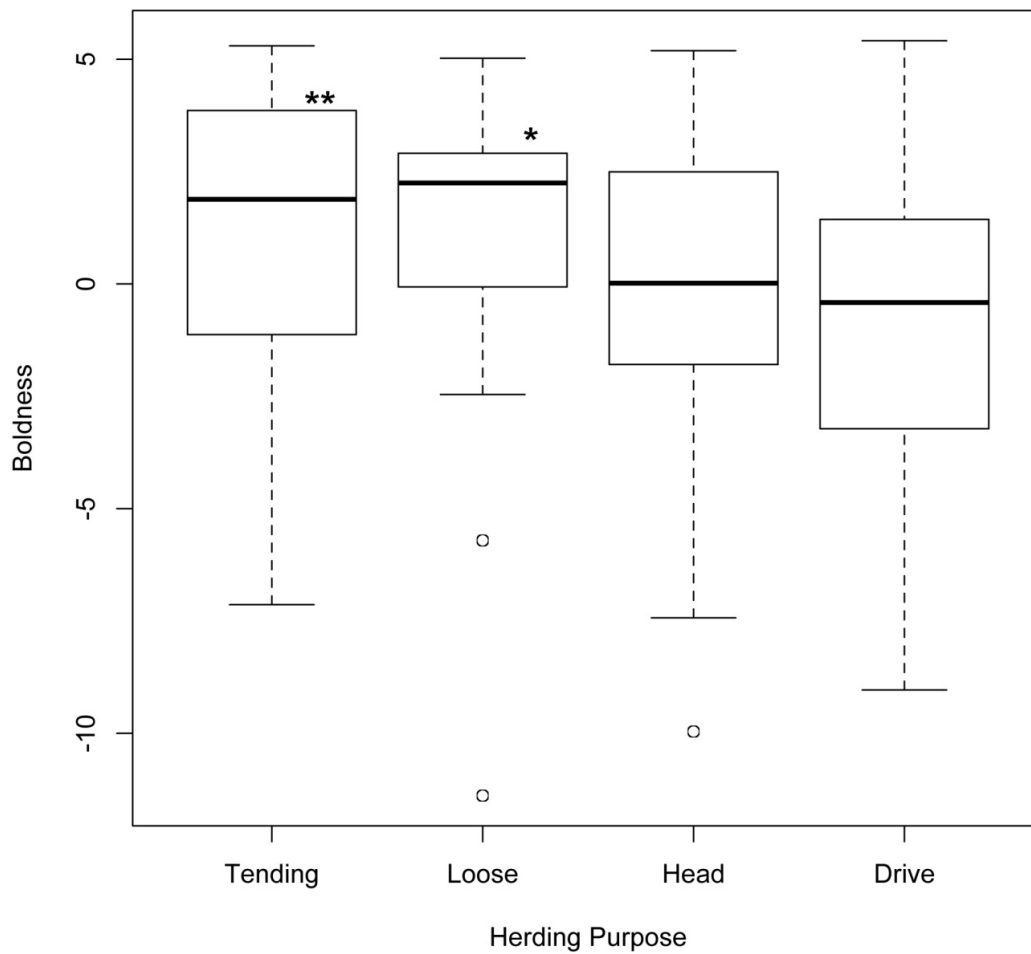

Figure 3.3. Effect of herding style on Boldness scores within the herding group. “Drive” is the reference group and refers to cattle herding breeds, “Head” to breeds with hard eye and a low herding stance, “Loose” to breeds with an upright herding stance and loose eye, and “Tending” to breeds developed to keep herds together in the one place. Significance in relation to the reference group is marked with asterisks. ‘*’ Denotes a significance level of <0.05, ‘’ a significance level of <0.005. The statistical model used was the ‘lm’ and ‘lme’ function in the statistical package R, and models were tested using the ANOVA function in R and the AIC value.**

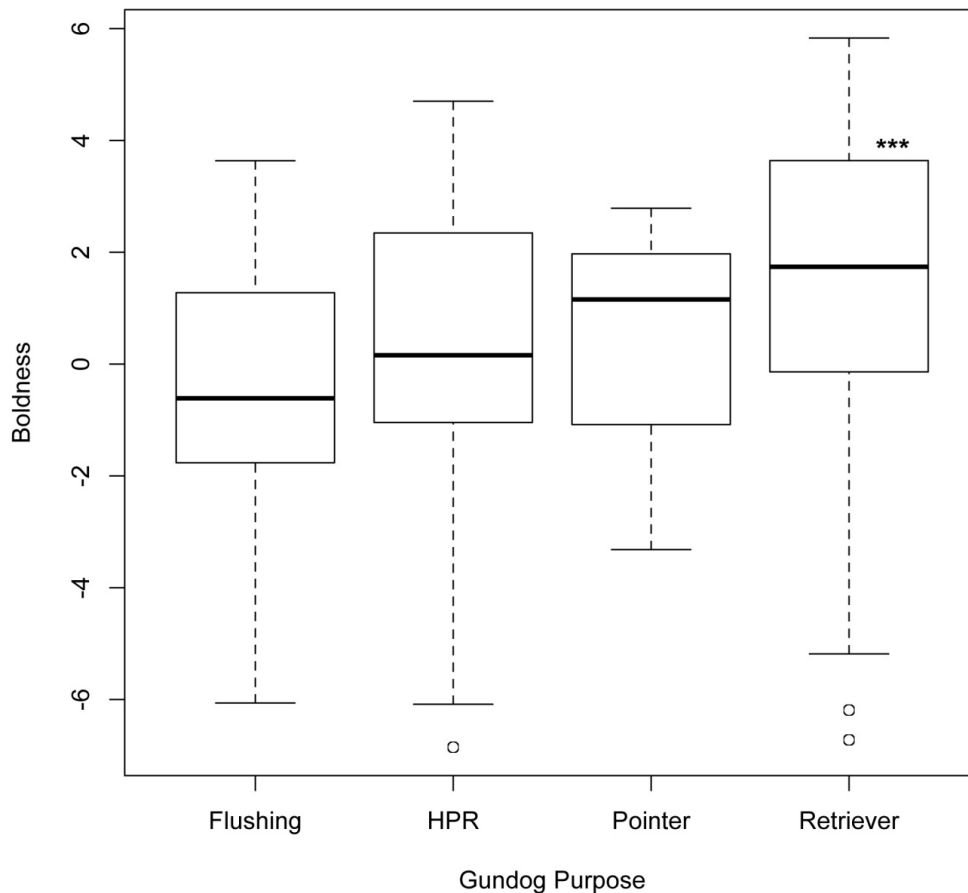

Figure 3.4. Effect of specific gundog purpose on Boldness scores within the gundog group. “Flushing” is the reference group and refers to setters and spaniels, “Pointing” refers to pointing breeds, “HPR” refers to hunting, pointing, retrieving breeds bred as multi-purpose gundogs, and “Retriever” refers to retrieving breeds. Significance is measured in relation to the reference group. ‘*’denotes a significance level of <0.001. The statistical model used was the ‘lm’ and ‘lme’ function in the statistical package R, and models were tested using the ANOVA function in R and the AIC value.**

Discussion

Boldness

In previous studies, boldness in dogs has been characterised by trainability, willingness to play with humans, a low reported frequency and intensity of fearful behaviour directed towards humans and dogs as well as non-social objects or events. It could be argued that the bold-shy continuum is neither the only not the best descriptive label for this axis of traits. For example, approach-avoid or friendly-fearful could just as easily capture the essence of the axis under

investigation and may be less open to interpretation. However, the long-established use of the bold-shy continuum concept across many taxa (e.g. Short & Petren 2008; Jones & Godin 2009; Harcourt et al. 2010; Michelena et al. 2009) encourages the adoption of this concept in dogs as well, and in this vein the authors adopt both the well-used concept of the bold-shy continuum and its specific applications to dogs as defined by previous studies (Svartberg 2005; Svartberg 2002; Svartberg & Forkman 2002; Turcsán et al. 2011).

This study identified one component with high positive loadings on items related to play with humans and other dogs and negative loadings on items relating to avoidance and behaviour indicating fear, suggesting that the component identified in this study is a similar component to that labelled “boldness” in previous studies (Svartberg & Forkman 2002; Svartberg et al. 2005; Svartberg 2002).

The PCA in the current study did not find trainability to be a key factor. This may have been influenced by the interpretation of trainability-related questions by respondents. The authors received informal comments of dissatisfaction with items related to trainability in the questionnaire, with some respondents feeling the questions were representative of their training ability rather than their dogs’ personalities. Even though these items have been validated in previous studies (Hsu & Serpell 2003; Svartberg 2005), we cannot be sure how the respondents in previous studies interpreted those questions. A cultural effect may be operating here. The current study included a much larger number of breeds and breed mixes from the general public than previous work, which included a smaller suite of breeds, all purebreds taking the Swedish Working Dog Club’s “Dog Mentality Assessment”. This may account for the lack of trainability items factoring into the boldness dimension in this study.

This study also differed from previous results by showing that, as well as having high positive loadings with human-directed play, boldness had high positive loadings on play with other dogs. This could be because of the broader number of breeds and breed mixes in this study. Previous work on play in different

breeds has focused on working groups such as herders, guardians, terriers and retrievers. It did not include sighthounds, scenthounds, spitz breeds, or companion breeds. Arguably, these latter breed groups may contain the least trainable dogs and dogs that are not as interested in playful interactions with humans as breeds in the herding, guardian and gundog groups. However, these breeds may have a stronger focus on dog-directed play interest than working breeds. This may explain why items relating to human-directed play interest and dog-directed play interest both featured strongly in the characterisation of boldness in this study.

Additional items to those used by Svartberg (2005) were included in the current survey to search for similarities or differences between coping styles and the shy-bold axis. In many cases, these were similar to questions in a previous study investigating dog personality in terms of positive and negative behavioural activation, two components of a principal components analysis (Sheppard & Mills 2002). The current study produced only one component in the PCA. The difference in results may have been influenced by the style of questions in both surveys. The current survey asked about the frequency or intensity of behaviours, whereas Sheppard and Mills (2002) asked about both frequency and intensity by asking respondents to agree or disagree with statements (Sheppard & Mills 2002). Survey items in the current study that corresponded to positive activation survey items in the study by Sheppard and Mills (2002) frequently did not align with boldness traits, yet did not feature in a principal component on their own. In contrast, items in the current study that corresponded with negative activation items tended to be items that loaded negatively on the boldness component, and therefore emerged as shy traits. More questions addressing activity level and frequency of active or inactive behaviour and emotional reactivity in the current survey may have revealed a second component. Sheppard and Mills (2002) found in a survey of 358 dog owners that several of the items they had expected to be related to positive activation failed to load more heavily on the positive activation component, and suggested several possible explanations for this. These items were similar to items in the current study that were expected to reveal whether a proactive coping style

corresponded to boldness and a reactive coping style corresponded to shyness. Those items in this study did not load strongly on any of the first three components in the PCA. It may be that researchers have not yet found a way to ask about these behaviours that is well understood by the dog-owning public. The results from the PCA reported here add weight to the factors identified by previous studies (Svartberg & Forkman 2002; Svartberg 2005), so in future it may be appropriate to approach this topic with a confirmatory approach using a confirmatory factor analysis rather than the exploratory approach employed here and in previous studies with PCA and exploratory factor analysis.

Breeds

Previous studies have shown that personality differs significantly among breeds, despite variability in personality within breeds (Wilson et al. 1994; Svartberg 2002; Svartberg 2006b). Inter-breed differences in components of boldness have also been identified. For example, playfulness is low and sociability is high in some guardian breeds while fearlessness is low in Labradors and Boxers (Svartberg 2006b). The results of the current study identify the Staffordshire bull terrier, Labrador retriever and German shepherd dog, as the three boldest breeds. These breeds are from three different groups (terrier, gundog, herding), but none of them from the guardian group, which was the boldest group on average. The only other attribute these breeds appear to share is being popular in Australia, with registrations in 2010 of 4695 for Staffordshire bull terriers, 4388 for Labrador retrievers, and 3932 for German shepherd dogs (Australian National Kennel Council registration statistics, 2011). Only three other breeds had more than 2000 Australian registrations in 2010. These breeds were the most commonly registered in their breed groups. We did not collect data on the purpose for which the dogs in the current study were bred as it was anticipated many owners would not know. Similarly, we anticipate that there would be many crossbreeds that may have been purposefully or accidentally bred, confounding the problem. So, it was impossible to identify a relationship between boldness and popularity. There was no significant effect of the origin of the dog (breeder, shelter, pet shop, friend or family, other) on boldness. Australians are reported to characterise the “ideal” dog as being safe with children, affectionate, obedient,

and healthy (King et al. 2009). It may be that playfulness, sociability, and curiosity coincide with temperament traits that are safe with children and friendly. An alternative interpretation could be that traits related to boldness are seen as desirable by the people most attracted to breeds reported as bold, and thus the expression of these traits could be inflated in some breeds. The problem of breed stereotypes was raised in the introduction, and this may also colour how owners are likely to view their dogs. If they own a breed they believe to be friendly and curious, they may be more inclined to see these traits expressed in their dog.

Further research into popularity and to what extent breeders select breeding stock on temperament desired by the public may provide a better understanding of current selection pressures on dogs and aid in studies of breed groups and the origins of breed-typical behaviours. An alternative interpretation could be that traits related to boldness are seen as desirable by the people most attracted to breeds reported as bold, and thus the perceived expression of these traits could be inflated in some breeds. The problem of breed stereotypes was raised in the introduction, and this may also affect how owners are likely to view their dogs. If they own a breed they believe to be friendly and curious, they may be more inclined to see these traits expressed in their dog.

Breed Groups

Breeds were pooled into UKC group categories to examine the expression of boldness at a breed-group level. It has been suggested that breeds that behave most similarly are those that have been bred for the same purpose, which historically aligned with Kennel Club breed groups, but more recently may have shifted to broader purposes, such as dog sports or the show ring (Svartberg 2006b).

On average, the boldest group in this study contained the guardian breeds, including mostly molossid breeds such as mastiffs and livestock-guardian breeds, and breeds developed for guarding purposes, such as Doberman pinscher and Giant schnauzer. Previous research has found that such breeds,

where they were clustered together in their behaviour, are moderately low in sociability, low in playfulness and moderate in curiosity/fearlessness (Svartberg 2006b). In contrast, the current findings place the group as a whole at the bold end of the shy-bold continuum, which makes intuitive sense given a guard dog will not be as effective if it avoids potential danger rather than approaching it. Another study that defined boldness rather differently, as willingness to approach, or the opposite of fearful and aloof behaviour, placed the guardian group as the second-boldest group after terriers (Turcsán et al. 2011). The breeds in the guardian group tend to have size and shape in common, with most being large, heavyset breeds. Size and shape may be a factor that contributes to some of the behavioural similarities among breeds (Bradshaw et al. 1996). Being large and relatively heavy, may afford these breeds a degree of protection, which may encourage confidence around humans, dogs and novel items and situations. Furthermore, the height of dogs relative to humans may affect their interactions with us (Helton 2010) and how they perceive human signals (Helton & Helton 2010). The quality and quantity of their interactions with humans may affect their willingness to approach or be approached by humans. Specific data on the size of dogs in this study were not collected, so an investigation of the effects of size on boldness was limited to loose categories of purebred dogs only, based on the ideal heights recorded in breed standards. A tendency for boldness to decrease with decreasing size category was observed, but only the small size category was significantly different from the giant size category. It was impossible to separate these effects from the effects of breed group, as breed groups had a tendency to be dominated by a given size category. This relationship may be more thoroughly examined in the future if data were collected on height and weight of each subject.

Gundog breeds were on average the second-boldest group in the current study. This group includes retrievers, pointers, spaniels and setters. In previous studies, gundog breeds have been identified as very playful (Svartberg 2006b; Bradshaw et al. 1996), very sociable, and displaying high curiosity/fearlessness (Svartberg 2006b). It would therefore follow that, as a group, they rate on the bold end of the shy-bold continuum. Their distribution in this study was skewed towards

two popular family pets: the Labrador retriever and Golden retriever, together accounting for 44% of the gundog group. Both these breeds rated high in boldness and may have inflated the boldness score for this group. Indeed, the current analysis of the gundog group based on specific tasks the breeds were originally developed for showed that retrievers are significantly bolder than other types of gundog. Turcsán et al. (2011) placed gundog breeds as a collective roughly equivalent to the guardian breeds in boldness and the highest in dog sociability, which is another trait that may contribute to boldness scores in this study.

Moderately bold groups were the Northern and Spitz breeds and the herding-breed groups. Spitz breeds are uncommon in the sparse literature of breed-specific temperament in dogs, and the way these breeds are clustered differs among kennel clubs. Spitz breeds do not fit neatly into the genetically defined groups of Parker et al. (Parker et al. 2007), but may feature most in the ancient breeds cluster, which rates low on boldness. Siberian huskies and Finnish lapphunds accounted for 51% of the group in the current study and both breeds were rated moderately bold. The Siberian husky is a sledding dog and the Finnish lapphund a reindeer-herding breed. An important aspect of sled dogs is that they are social with other dogs (Coppinger & Coppinger 2001). Gregarious breeds may display low levels of social fear and high interest in play, which are two characteristics of boldness in dogs. Many herding breeds have also been found to be high in playfulness compared to other breeds, and moderately high in curiosity/fearlessness and sociability (Svartberg 2006b). With a gregarious sledding breed and a herding breed accounting for more than half the individuals in the Northern group, perhaps this eclectic group could be more parsimoniously grouped according to purpose, like other UKC groups. The herding group contains a large variety in temperaments, with the current study showing breeds rating very bold, moderately bold, and very shy all within the herding group. Furthermore, previous studies have also proposed that this group may be a false grouping, with different herding breeds tending to fit into several different breed clusters (Svartberg 2006b; Bradshaw et al. 1996).

In the current study, an additional analysis of the breeds within the herding group when considered on the basis of their traditional herding styles revealed that there was a significant effect of herding style on boldness. Tending breeds such as the German shepherd dog and Belgian shepherd (all types) were the boldest, and loose-eyed breeds with an upright herding style, such as collies and Australian shepherds, were the second boldest. The breeds categorised as hard-eyed and cattle-driving herders were on the shy end of the scale. In the current survey, these latter types were dominated by breeds currently still used as livestock workers, whereas the loose-eyed and tending breeds are generally no longer used as working dogs in Australia, except perhaps on a small scale on hobby farms. It may be that herding breeds more often kept as pets in modern times have lost some of the emotional reactivity that may manifest as shyness. Terriers fell in the middle of the shy-bold continuum in this study, neither particularly bold nor particularly shy. The group is often described as courageous, hard-headed, and possessing incredible perseverance (Skinner 2010; Kern 1987; Palika 2007). The group was rated as the boldest group by Turcsán et al. (Turcsán et al. 2011), whether they were considered in their traditional kennel club group of terriers or in a group based on genetic clusters combined with mastiff breeds as per Parker et al. (2007). The results of the current study placed the group at a more moderate level of boldness, but many terriers are small and not known for friendliness towards unknown dogs (Seksel et al. 1999). These traits may have brought the boldness score down.

Breed groups at the shyer end of the shy-bold axis included the mixed breeds as a collective, the Sighthound and Pariah dogs group, and the Scenthound group. Mixed breeds were numerous in the study and as a group were significantly shyer than the terrier group. The mixed breeds in the study may have had an over-representation of terrier and herding-breed mixes. Dogs with one herding or terrier parent accounted for 60% of all mixed breeds.

The companion breeds group was the shyest group in this study. It is another group that has not received as much attention in previous studies on boldness as other groups. That said, the group was rated as moderately bold and low in

sociability in one study (Turcsán et al. 2011). This group contains many small breeds that may perceive themselves to be at greater risk when confronted with novel situations due to their relative size compared to the size of the objects, dogs and humans around them. No statistics are available for companion-breed mixes, but such dogs are readily available and, in some cases, purposely bred. In the current survey they made up 25% of the companion-breed group and 18% of the mixed-breed group. It is possible that in small dogs, there is less focus selection for temperament because, however problematic, they are more easily managed than larger dogs. The companion-breed group stood apart from the other breed groups as the only group where the boldest breed was not one of the most popular breeds in the group in terms of registration numbers.

Conclusions

This study supports the existence of the shy-bold continuum as an overarching super-trait in dogs and adds to the body of evidence suggesting that sociability and playfulness are associated with boldness. The results of this study question the conclusion that this super-trait should be called “boldness”. It is likely that boldness in this and similar studies is a multi-faceted component of dog personality that may represent a mixture of risk aversion, optimism, emotional reactivity and sociability. Many factors were found to influence boldness scores. There was no evidence to suggest that coping styles and the shy-bold axis assess very similar features of dog behaviour. Future research seeking novel ways to ask dog owners about anticipation, routine, and proactive or reactive behaviours, may identify practical indicators of coping style without experimental data.

Mixed findings in previous studies of behavioural differences and similarities across breed groups may have missed a degree of detail available in searching for patterns and possible origins of behaviour, and therefore, behavioural predictability. Further research into the specific purposes of different breeds may provide a more consistent pattern of breed behaviour.

Acknowledgements

The authors would like to thank the financial contribution of Black Dog as well as the owners of the websites, e-mail lists and newsletters that agreed to circulate links to the online survey. The authors would also like to thank the valuable contributions of W. Helton in the review process, and one anonymous reviewer.

4 Age, sex and reproductive status affect boldness in dogs

Melissa J. Starling^{a*}, Nicholas Branson^b, Peter C. Thomson^a, Paul D. McGreevy^a

^a *Faculty of Veterinary Science, University of Sydney, NSW, Australia*

^b *Deakin Research , Deakin University, VIC, Australia*

This paper is in press with the *Veterinary Journal*, 2013.

Abstract

“Boldness” in dogs is believed to be one end of the shy-bold axis, representing a super-trait. Several personality traits fall under the influence of this super-trait. Previous studies have found that boldness is affected by breed and breed groups, influences performance in sporting dogs, and is affected in some cases by the sex of the dogs. This study investigated the effects of dog age, sex and reproductive status on boldness in dogs by way of a dog personality survey circulated amongst Australian dog owners. Age had a significant effect on boldness ($F=4.476$, $df=16$, 758 , $P < 0.001$), with boldness decreasing with age in years. Males were bolder than females ($F=19.219$, $df=1$, 758 , $P<0.001$) and entire dogs were bolder than neutered dogs ($F=4.330$, $df=1$, 758 , $P< 0.038$). This study shows how behaviour may change in adult dogs as they age and adds to the literature on how sex and reproductive status may affect personality in dogs.

Keywords: Dog personality, age, sex, reproductive status, boldness

Introduction

The study of personality may offer a framework to explain some of the variation observed in animal behaviour. One of the chief benefits of understanding behavioural variability in animals is improving our ability to predict how individuals are likely to behave (Svartberg 2003). Such information can be used to modify the way particular animals are managed and trained. In addition, it may inform decisions on the suitability of particular environments they are kept in, and the work they may be used for. Fine-tuning the way we interact with and keep animals at the individual level to best suit that individual's strengths and weaknesses has the potential to improve animal welfare and improve human-animal interactions.

Boldness in dogs has been characterised by trainability, willingness to play with humans, a low reported frequency and intensity of fearful behaviour directed towards humans and dogs as well as non-social objects or events in previous studies (Svartberg 2002; Svartberg 2005; Svartberg & Forkman 2002). In a previous study using the methods described here, we identified one component with high positive loadings on items related to play with humans and other dogs and negative loadings on items relating to avoidance and behaviour indicating fear (Starling et al., in press). The loadings suggest that the component we identified is similar to that labelled "boldness" in previous studies (Svartberg & Forkman 2002; Svartberg et al. 2005; Svartberg 2002).

The domestic dog (*Canis lupus familiaris*) is one of the most commonly kept animals in Western societies, with 36% of households in Australia including one or more dogs (Australian Companion Animal Council, 2010). Dogs often live in close proximity to humans, sharing living spaces in the home and public outdoor spaces for leisure activities and exercise. It is therefore of particular importance to understand our canine companions and manage and accommodate their basic nature and needs. These may change as the dog matures and ages. For example, aging dogs are known to approach cognitive tasks in different ways (Salvin et al. 2011) and may lose behavioural inhibition or the use of their senses as they age

(Salvin et al. 2012). These physiological changes may have an effect on perceived personality. It is unknown when personality in dogs stabilises, but previous studies suggest behaviour in dogs under 9 months of age is not strongly indicative of adult dog behaviour in most cases (Goddard & Beilharz 1986). There are remarkably few studies investigating whether personality in dogs may change as they age beyond early adulthood but prior to old age (Jones & Gosling 2005).

The effect of sex and reproductive status on dog personality has been assessed in a limited number of studies. There is some evidence to suggest that neutered dogs are more aggressive, more excitable, and more anxious than entire male and female dogs (Farhoooy & Zink 2010). Male neutered companion dogs are believed to be more trainable than male entire dogs (Serpell & Hsu 2005), and male dogs have been shown to be bolder than female dogs, although this association has not been identified in high performing sport dogs (Svartberg & Forkman 2002). In summary, the effects of sex and reproductive status on dog personality have not been widely documented or unified in a single study. The current study examines the effects of sex and reproductive status as well as age on aspects of personality in the dog.

Methods

Item Generation

A survey was developed for dog owners to report on the personality of their dogs. Demographic data were collected on the age and gender of the dog owners, where and when they had obtained the dog, and how long they had owned it. Survey items were drawn from the Canine Behavioural Assessment and Research Questionnaire (CBARQ) (Hsu & Serpell 2003) and guided by previous work by Svartberg on boldness in dogs (Svartberg 2002; Svartberg 2005). CBARQ has been validated by correlating survey answers with professional diagnoses of behavioural problems (Hsu & Serpell 2003). For the current questionnaire, items from CBARQ that may be associated with boldness or shyness and indicated by everyday dog behaviour were retained, with the

exception of stranger-directed aggression. This factor has been shown to have a low loading on the component associated with boldness and was not strongly associated with aggressiveness in everyday life (Svartberg 2005). It is possible that aggressiveness as a trait is unrelated to the shy-bold axis (Svartberg 2005; Scott & Fuller 1965) or that it can be readily expressed at either end of the spectrum since aggression can emerge in bold dogs that are motivated to guard and shy dogs that are pushed to defend. Items not found to be associated with boldness and shyness were also excluded to focus on items most likely to be predictive of future behavioural tendencies. In addition, because Svartberg (2002; 2005) showed that separation-related behaviour, predatory behaviour, owner-directed aggression, and dog-directed behaviour in the home environment had no correlation with the Swedish Working Dog Club Dog Mentality Assessment (DMA) personality traits, and to that extent were not validated, these items were also excluded.

Additional items covering play behaviour developed by Svartberg (2002; 2005) were included in our questionnaire. It used two forms of five-point rating scales, with different sections using either of those forms. One was a semantic differential-type rating scale as used by Hsu and Serpell (2003) and the other offered a selection of graded options: “never”, “seldom”, “sometimes”, “usually”, and “always”, that referred to the frequency of the behaviour in the recent past.

A further section exploring proactive and reactive behaviour was added to the survey. It included questions developed from reviews of the characteristics of proactive and reactive coping styles (Coppens & de Boer 2010; Koolhaas et al. 1999; Koolhaas et al. 2010). These questions used the semantic differential-type 5-point rating scale on which respondents were asked to rate the intensity of their dog’s behaviour ranging from 0, where the behaviour was not observed, to 4, where the behaviour was extreme.

Participants

The survey was circulated via Australian internet forums and e-mail lists with a focus on domestic dogs. Respondents were sought exclusively from Australia to

avoid international variables being introduced into the results. Respondents were 18 years or over, and under 80 years in age, and were asked to report on a dog with which they lived. They were requested to complete additional surveys for additional dogs if they lived with more than one.

Statistical analysis

Statistical analyses were carried out with the program R (R Development Core Team, 2011). Mean substitution was used for missing data as per Svartberg (2002; 2005), and surveys with more than five missing responses were not used. A principal components analysis (PCA) was run on the results from the survey. The number of components extracted was determined by the scree plot method, as there was a clear division in the scree plot.

The component extracted from the PCA was subjected to further analysis using linear mixed models using the 'lme' function in R and was used as a boldness measure. Fixed effects included dog gender, age, reproductive status, and United Kennel Club (UKC) breed group, owner gender, owner age group, and dog's origin. Breed was considered a random effect nested within the fixed effect UKC Breed Group. Terms were first tested for significance using the t-test or 'anova' function in R and, if they were significant, added to a linear model. The terms in the models were tested using the 'anova' function, comparing the linear model containing the new term with a linear model excluding the new term. The Akaike Information Criterion (AIC) value was also used to assess the model-of-best-fit. The UKC breed groups included Companion, Guardian, Gundog, Scenthound, Herding, Terrier, Sighthound and Pariah and Northern and Spitz groups. UKC breed groups are closest to the international convention adopted by Fédération Cynologique Internationale (FCI), but use fewer groups. The reduced breed groups better suited the smaller number of breeds in the current study's data. The linear mixed model was then compared to the linear model containing all significant fixed-effect factors using a likelihood ratio test using the 'anova' function in R to assess the significance of the random effects in the model. Dogs of mixed breed heritage were assigned to a breed group called "Mixed" if their breed composition was unknown or only one parent was known. Where all

breeds listed in the makeup of a mixed breed individual belonged to the same UKC group, that dog was categorised as also belonging to that UKC group. Otherwise the individual was categorised as “Mixed”. Dog age, sex and reproductive status were entered into the model as fixed effects.

Results

Principal Components Analysis

The survey generated 1054 responses that could be used. The PCA produced one major component (PC1) called “Boldness” that accounted for 21.4% of the variation. The retained component was characterised by high loadings on factors relating to play and sociality and negative loadings on avoidance and other behaviours indicating fear. Although this component had much in common with the over-arching personality called “Boldness” in other studies (Svartberg 2005; Svartberg 2002), it has not been validated with behavioural measures.

Linear Regression

The model-of-best-fit included five terms: age (in years), sex, reproductive status, breed, and breed group. Age and gender of the owner were not significant, and nor was origin of the dog or age of the dog when acquired. So, these terms were not included in the final model. The estimated regression coefficient and related output of the model-of-best-fit is shown in Table 4.1. Boldness in general decreased with age (Figure 4.1) ($F=4.476$, numDF=16, denDF=758, $P<0.001$). Age was treated as a categorical variable and is presented as such here to enable better comparison with studies where dogs are pooled into age groups (Kubinyi et al. 2009). Male dogs were bolder than female dogs (Fig. 2a) ($F=19.219$, numDF=1, denDF=758, $P<0.001$), and entire dogs of either sex were bolder than desexed dogs of either sex (Figure 4.2b) ($F=4.330$, numDF=1, denDF=758, $P=0.038$). An interaction between sex and reproductive status was tested and revealed no significant interaction. Nor were there any significant interactions between breed group and age. In most cases, there were no correlations between breed group and sex. The exception was a significant correlation between the Scenthound group and sex (male) (Reg coef. =-3.315,

S.E.=1.511, DF=752, $P=0.029$), where numbers were low ($N=9$). Further analysis of breed and breed group is discussed in a second paper (Starling et al., submitted).

| | Regression Coefficient | Std. Error | DF | N | P |
|--|-------------------------------|-------------------|-----------|----------|---------------------|
| (Companion, Female, Neutered, Age <1 year) | -0.861 | 0.488 | 763 | | 0.0784 |
| Entire | 0.549 | 0.264 | 763 | 214 | 0.038* |
| Male | 0.768 | 0.198 | 763 | 505 | <0.001*** |
| Guardian breed group | 3.088 | 0.543 | 264 | 82 | <0.001*** |
| Gundog breed group | 1.947 | 0.474 | 264 | 162 | <0.001*** |
| Herding breed group | 1.575 | 0.445 | 763 | 228 | <0.001*** |
| Mixed breed group | 1.203 | 0.340 | 763 | 234 | 0.002** |
| Northern breed group | 1.673 | 0.651 | 264 | 47 | 0.012* |
| Scenthound breed group | 0.627 | 0.889 | 264 | 20 | 0.481 |
| Sightound breed group | 1.106 | 0.663 | 264 | 50 | 0.097 |
| Terrier breed group | 1.466 | 0.547 | 763 | 80 | 0.008* |
| Age1 | -0.014 | 0.457 | 763 | 120 | 0.975 |
| Age2 | -0.889 | 0.475 | 763 | 100 | 0.062 |
| Age3 | -0.510 | 0.474 | 763 | 108 | 0.282 |
| Age4 | -0.894 | 0.484 | 763 | 96 | 0.065 |
| Age5 | -1.200 | 0.491 | 763 | 91 | 0.015* |
| Age6 | -2.090 | 0.512 | 763 | 79 | <0.001*** |
| Age7 | -1.270 | 0.528 | 763 | 66 | 0.016* |
| Age8 | -1.947 | 0.540 | 763 | 65 | <0.001*** |
| Age9 | -1.853 | 0.549 | 763 | 61 | 0.001*** |
| Age10 | -1.692 | 0.546 | 763 | 63 | 0.002** |
| Age11 | -2.243 | 0.660 | 763 | 33 | 0.001*** |
| Age12 | -1.647 | 0.731 | 763 | 24 | 0.025* |
| Age13 | -0.747 | 0.773 | 763 | 21 | 0.334 |
| Age14 | -2.139 | 1.075 | 763 | 10 | 0.047* |
| Age15 | -3.081 | 0.997 | 763 | 12 | 0.002** |
| Age16+ | -3.822 | 0.996 | 763 | 12 | <0.001*** |

Table 4.1. Shows the statistical output of the fixed effects from the final linear mixed model accepted including dog sex, reproductive status, age, breed, and breed group. Significance is relative to the 'Intercept' conditions: Companion breed group, female, neutered. "*" denotes a significance level of <0.05, "*" a significance level of <0.005, and "****" a significance level of <0.001. Age in years was considered a categorical variable rather than a continuous one to show where results deviated from a linear relationship. The statistical model used was the 'lm' and 'lme' function in the statistical package R, and models were tested using the ANOVA function in R and the AIC value.**

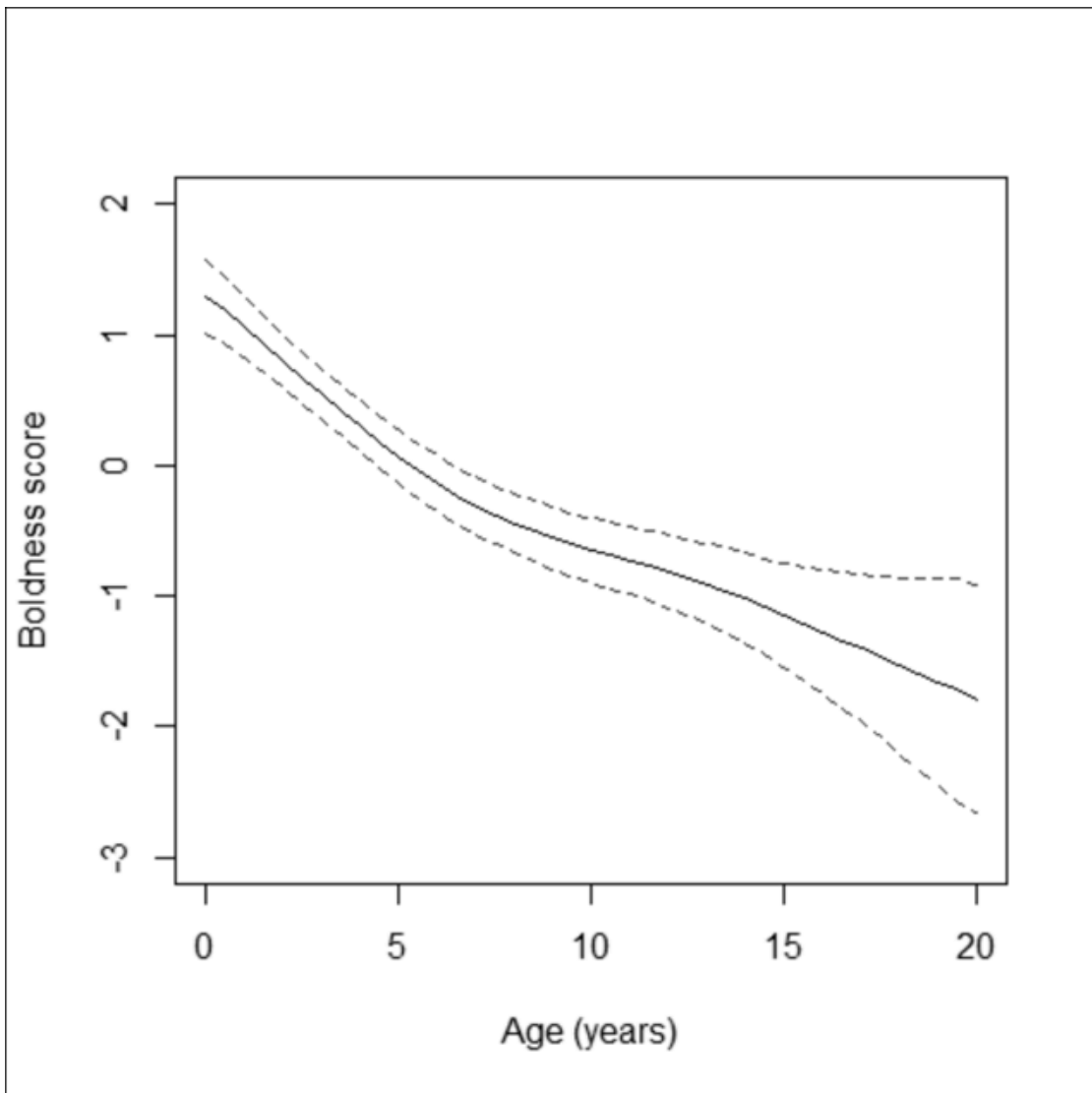

Figure 4.1. Association between boldness and age in dogs using a spline function. Boldness decreases as age decreases. The statistical model used was the 'lm' and 'lme' function in the statistical package R, and models were tested using the 'anova' function in R and the AIC value.

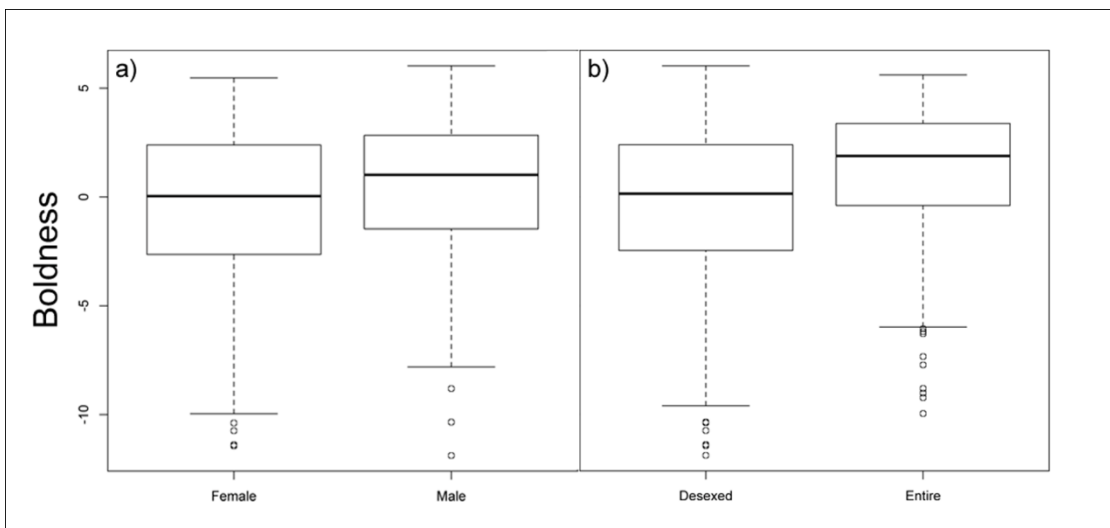

Figure 4.2. a) shows boldness in male versus female dogs. Boldness scores as extracted from the first component of a principal component analysis is significantly greater in males than in females. The statistical model used was the 'lm' and 'lme' function in the statistical package R, and models were tested using the 'anova' function in R and the AIC value. b) shows boldness in entire versus desexed dogs of both sexes. Boldness scores as extracted from the first component of a principal component analysis are significantly greater in entire than in neutered dogs of both sexes.

Discussion

Boldness

The results of the current study complement those from a previous report by Kubinyi (2009) that found male dogs were bolder than female dogs and younger dogs of both sexes were bolder than older dogs (see Kubinyi et al. 2009 for details).

Age

This study showed a significant negative correlation between age of dogs and boldness: boldness scores decreased as the age of the dog increased. Published personality and temperament studies in dogs have a strong focus on animals under 2 years of age, possibly because such studies are often aimed at improving methods of selecting individual dogs for training programs to become working dogs, for example for police, military, or guide dogs (Jones & Gosling 2005). Conversely, there has also been some focus on aging dogs, generally 10 years and over, that may be subject to canine cognitive dysfunction (e.g. Chan et al. 2002; Neilson et al. 2001). So dogs between these age groups are poorly represented in personality studies.

In the Australian pet dogs sampled, a shift was found towards the shy end of the shy-bold axis as the dogs aged. Until age 13 years, a gradual shift towards shyness was observed and then the trend became much sharper after 13 years. The latter shift may be explained by age-related degenerative conditions such as osteoarthritis. Physical discomfort may lead to dogs taking fewer risks and being less inclined to interact with other dogs or people. Whilst measures of age-related cognitive decline were not collected in our study, Neilson et al. (2001) reported a reduction in greeting and attention-seeking behaviour in dogs with

this condition. Therefore, the results presented in this paper highlight the importance of undertaking further research to assess the contribution of age-related physical and cognitive degenerative conditions to the expression of a less bold personality in dogs.

The gradual decline in boldness between the age of 1 year and 13 years, while not nearly as dramatic, may be far more important. There is no published precedent to the knowledge of the authors for this significant trend. Training history and life experiences in general also play a role in dog behaviour (Goddard & Beilharz 1986). It is possible that engaging in bold behaviour is not an overall rewarding experience for dogs in this population. For example, approaching social objects such as humans and other dogs may result in aversive experiences such as aggressive or threatening behaviour directed towards the dog approaching. Experiences such as these may result in a decrease in the frequency of behaviours positively related to boldness and an increase in frequency and intensity of the avoidance behaviours towards non-social objects negatively associated with boldness. This possibility raises questions about how dogs' interactions with social and non-social stimuli are routinely managed by dog owners (see McGreevy et al. 2012 for review), and the long-term effects this may be having on both how the dogs are likely to behave and their emotional state in their day-to-day lives.

A previous study of 264 dogs found that sociability decreased with age, but no differences in personality between sex or breed were detected (Wahlgren & Lester 2003). Sociability towards other dogs has been shown to decrease as dogs age, but from 4 years to 8 years old, sociable behaviour is affected by the time the dog spends with the owner (Kubinyi et al. 2009). Female dogs in the 4-8 years age group are more sociable towards conspecifics than male dogs in this age group (Kubinyi et al. 2009).

It is possible that as dogs age and they accumulate ever more experiences they naturally become less engaged in their surroundings, lose interest in exploration and show a reduction in excitement. Perhaps similar to a "been there, done that"

effect. This may manifest itself in more aloof or shy behaviour as they become less inclined to approach strangers or to engage in social and playful interactions. This may be such a gradual decline in interest that it is largely overlooked by owners. Chimpanzees show a decrease in “Openness”, “Extraversion” and “Emotionality” with age as reported by their familiar keepers (King et al. 2005), and the same trend has been found in humans (e.g. McCrae et al. 1999), suggesting there may be a biological basis for a decrease in certain personality traits (Costa & McCrae 2006) related to boldness. A slight decrease in curiosity/fearlessness, sociability and aggressiveness with age has been reported in German shepherd dogs under 5 years of age (Svartberg 2007). This rough indication hints at the broader results reported here.

It is also possible there is naturally a sampling bias present. A previous study found evidence for greater energy expenditure and higher mortality in dogs scoring high in traits related to Boldness (Careau et al. 2010). Bold dogs may live fast and die young, or be culled early from the population for unwanted boisterousness, leaving an increasing imbalance in the shy-bold continuum towards shyness in older age groups.

Sex and Reproductive Status

This study revealed that boldness in dogs is influenced by both the sex of the dog and the dog’s reproductive status, and there was no interaction found between these two factors. Previous studies that examined the effects of sex on temperament revealed mixed findings.

Fearfulness

Neutered female German shepherds have been found to be more emotionally reactive than entire females (Kim et al. 2006), and it has been found that neutered female dogs show more ‘fearful’ behaviour and neutered male dogs show more aggressive behaviour towards people (Meuten 2002). These findings along with the results of the current study suggest it is possible that neutering alters a dog’s willingness to engage in social behaviours and/or their desire to avoid novel or potentially frightening non-social objects.

Trainability and Boldness

Male dogs of some breeds have been found to be more trainable than females of the same breed, but this effect is not uniform across all breeds (Serpell & Hsu 2005). The same study found neutering had no effect on the trainability of female dogs of any breed, but did improve trainability in males of some breeds (Serpell & Hsu 2005). Survey questions on trainability in the current study featured in the identification of boldness in another study (Svartberg 2002). It was found in that study that male dogs were bolder than female dogs, but this effect did not hold for high performance sports dogs (Svartberg 2002).

Sociability and Calmness

There is some evidence that neutered dogs are more likely to be obese, although this effect may differ between breed groups and with age (McGreevy, Thomson, et al. 2005b). Obesity may result in dogs being less inclined to move and therefore less inclined to engage in behaviours such as greeting and playing and thus cause the dog to appear more shy. However, avoidance behaviour directed towards non-social objects is negatively correlated with Boldness in the current study. Shyness is not defined simply by a lack of behavioural response, so a lack of motivation alone is unlikely to result in a report of shyness.

The finding in this study for male dogs to be significantly bolder than female dogs combined with findings in other studies of males being bolder (or expressing more of a trait related to boldness) under certain conditions suggests that while this study gives a broad picture of boldness between sexes in dogs, there are other factors beyond the remit of the current study that may play a role. These could include the effects of different levels of training and training for different purposes, for example.

Conclusions

This study shows how behaviour may change in adult dogs as they age. It is recommended that this area be investigated in more detail. Understanding

changes in behaviour may aid in the interpretation of a range of scientific and clinical findings related to cognition, personality, affective state, and how dogs respond behaviourally to stimuli they encounter and how the way they interact with humans and other dogs may change over time.

Conflict of interest statement

None of the authors of this paper has a financial or personal relationship with other people or organisations that could inappropriately influence or bias the content of the paper.

Acknowledgements

The authors would like to acknowledge the support of Black Dog Wear Pty Ltd and Positive Puppies as well as the administrators of Dogzonline forum and Dogtree, who allowed the survey to be distributed via their online forums. The authors also acknowledge the help of individuals who volunteered to distribute the survey far and wide amongst friends, co-workers and family.

Author Contributions

The following chapter includes an original paper submitted to the peer-reviewed journal "PloS One". The ideas, development, data collection, analysis and preparation of the manuscript were all the primary responsibility of the candidate, working within the Faculty of Veterinary Science under the supervision of Dr Paul McGreevy (primary supervisor) and, Dr Nicholas Branson (associate supervisor). Dr McGreevy and Dr Branson both assisted in the development of the study in their roles as supervisors. Denis Cody assisted in data analysis and in preparing the response latency graphs. Timothy Starling assisted in the design and construction of the apparatus and contributed to related sections in the manuscript.

The inclusion of co-authors reflects the fact that the work came from an active collaboration between researchers and acknowledges input into team-based research.

Confirmation of Co-Authorship of Published Work

I, *Melissa Starling*, contributed to the organisation, project design, data collection, statistical data analysis and preparation of the manuscripts entitled "***Canine Sense and Sensibility: Tipping points and response latency variability as an optimism index in a canine judgement bias assessment***".

Melissa Starling  Date 2nd August 2013

I, as a Co-Author, endorse that this level of contribution by myself and the candidate indicated above is appropriate.

Dr Nicholas Branson  Date 25.7.13

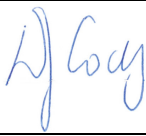
Denis Cody  Date 2.8.13

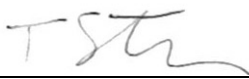
Timothy Starling  Date 2/8/13

Dr Paul McGreevy  Date 17.7.13

5 Canine Sense and Sensibility: Tipping points and response latency variability as an optimism index in canine judgement bias assessments

Melissa J. Starling¹, Nicholas Branson², Denis Cody³, Timothy R. Starling and Paul D. McGreevy¹

¹ Faculty of Veterinary Science, University of Sydney, NSW, Australia

² Deakin Research, Deakin University, VIC, Australia

³ Indice Ecotech Pty Ltd, VIC, Australia

This paper has been submitted to the journal *PLoS One*

Abstract

Recent advances in animal welfare science used judgement bias, a type of cognitive bias, as a means to objectively measure an animal's affective state. It is postulated that animals showing heightened expectation of positive outcomes may be categorised optimistic, while those showing heightened expectations of negative outcomes may be considered pessimistic. This study pioneers the use of a portable, automated apparatus to train and test the judgement bias of dogs (n=46). A Cox's Proportional Hazards model was used to analyse censored response latency data. Dog and Cue both had a highly significant effect on latency and risk of touching a target (DF=18.57, LRT=261.86, $P<0.001$; DF=10.19, LRT=616.9, $P<0.001$ respectively). This indicates that dogs respond differentially to ambiguous cues and different dogs are more or less likely to respond to various ambiguous cues, indicating that judgement bias both exists in dogs and differs between dogs. Test number also had a significant effect (DF=2.0, LRT=16.45, $P<0.001$), indicating that dogs were less likely to touch the target over successive tests. Detailed examination of the response latencies revealed tipping points where average latency increased by 100% or more, giving an indication of where dogs began to treat ambiguous cues as predicting more negative outcomes than positive. Variability scores were calculated to provide an index of optimism using average latency and standard deviation at cues after the tipping point. The use of a mathematical approach to assessing judgement bias data in animal studies offers a more detailed interpretation than traditional statistical analyses. The development and refinement of an appropriate mathematical model are discussed.

Introduction

Animal welfare science focuses on the assessment and the potential optimisation of the quality of life of animals. Animal welfare studies have traditionally focused on identifying negative states tied to stressors such as those causing pain, fear, anxiety and frustration (Boissy et al. 2007; Duncan 2006), as it was assumed that these conditions reflect poor welfare and that therefore good welfare results from the absence of these states (Duncan 2006). However, there are problems

with this approach. For example, negative states are adaptive and consequences of a stress response may be protective (Korte et al. 2007). It has been suggested that assessments of animal welfare should not focus purely on avoiding pain and suffering, but should also place value on positive, pleasurable activities and resources (Seligman & Csikszentmihalyi 2000). It is therefore of growing importance to identify accurate indicators of positive and negative affective state in animals.

One potential method of identifying positive and negative affective states in animals is cognitive bias. Cognitive bias is a term that has been used in the human literature to describe the effects of affective state on a range of cognitive processes such as information processing and decision-making (Hinde 1985; see Paul et al. 2005 for review). It is now being put to similar use in non-human animals, where it has been found the cognitive process of judging how to interpret ambiguous signals is under the influence of current affective state. This is called judgement bias, and is a type of cognitive bias. A judgement bias refers to how animals interpret ambiguous signals and whether they expect more positive or negative outcomes. A negative affective state leads to an expectation of negative outcomes and thus a negative bias in the interpretation of ambiguous signals. This has been referred to in the animal literature as pessimism (e.g. Bateson & Matheson 2007; Burman et al. 2009). In contrast, a positive affective state leads to an expectation of positive outcomes and positive biases in signal interpretation, which has been referred to as optimism (e.g. Matheson et al. 2008; Brydges et al. 2011). Environmental conditions that induce either a state of positive or negative affect can be used to test this concept in animals by changing environmental conditions to induce either a putative positive or negative affect and then testing whether judgement bias changes correspondingly. This approach has been reported in rats (Burman, Parker, Paul & Mendl 2008a; Harding et al. 2004), starlings (Brilot et al. 2010; Matheson et al. 2008; Bateson & Matheson 2007; Douglas et al. 2012; Brydges et al. 2011), sheep (Doyle et al. 2010a; Doyle et al. 2011; Destrez et al. 2012), chickens (Lindström 2010; Salmeto et al. 2010), cats (Tami et al. 2011), macaques (Bethell et al. 2012), pigs (Douglas et al. 2012), dogs (Mendl, et al. 2010a; Burman et al. 2011)

and honeybees (Bateson et al. 2011). In the species studied to date, negative judgement biases tend to positively correlate with conditions known to induce negative affect, and positive judgement biases positively correlate with conditions known to induce positive affect. Furthermore, pessimism has been reduced with the use of drugs designed to reduce fear in lambs (Destrez et al. 2012) and pessimism has been associated with physiological indicators of elevated distress in honeybees (Bateson et al. 2011). These results support the use of judgement bias in animals as a potential indicator of both positive and negative affective state.

This study reports on the trial of a portable, automated apparatus to train an operant task and then discrimination between auditory cues of different tones (low and high) to reveal dogs' expectations and therefore their judgement bias. The device was designed to collect data on judgement bias in a range of dogs from different environments, investigate population levels of optimism and pessimism and explore factors that may affect its expression.

Methods

Subjects

The subjects included 46 dogs of various breeds. Seventeen of the dogs (aged 1-6 years) were recruited via a positive training and pet boarding company based in the North Shore suburbs of Sydney, Australia. These dogs belonged to members of the public and thus were subject to variable housing, feeding and exercise arrangements. Twelve dogs were sourced from Assistance Dogs Australia's (Heathcote, NSW, Australia) advanced training facility. These dogs were 1-2 years old. Eleven dogs (aged 1-3 years) were sourced from a private security company. Details of the dogs in the study are shown in **Table 5.1**. Dogs older than eight years were excluded to avoid recruiting dogs that may have been affected by canine cognitive dysfunction. Dogs younger than one year were excluded to avoid the possible influence of social immaturity on cognitive bias.

Apparatus

The apparatus used in this study was designed to be portable and easy to set up and operate. A diagram of the apparatus is shown in **Figure 5.1**. It consisted of three major external components: an interactive target that detected movement through the use of an infrared photointerruptor, and two feed trays assigned to either lactose-free milk or water. As a diet high in lactose is associated with diarrhoea in some dogs (Bennett & Coon 1966), lactose-free milk was chosen as a liquid reward to avoid causing digestive upsets. Throughout training and testing, dogs received a set volume of lactose-free milk and water ranging from 1-5mL, depending on their bodyweight.

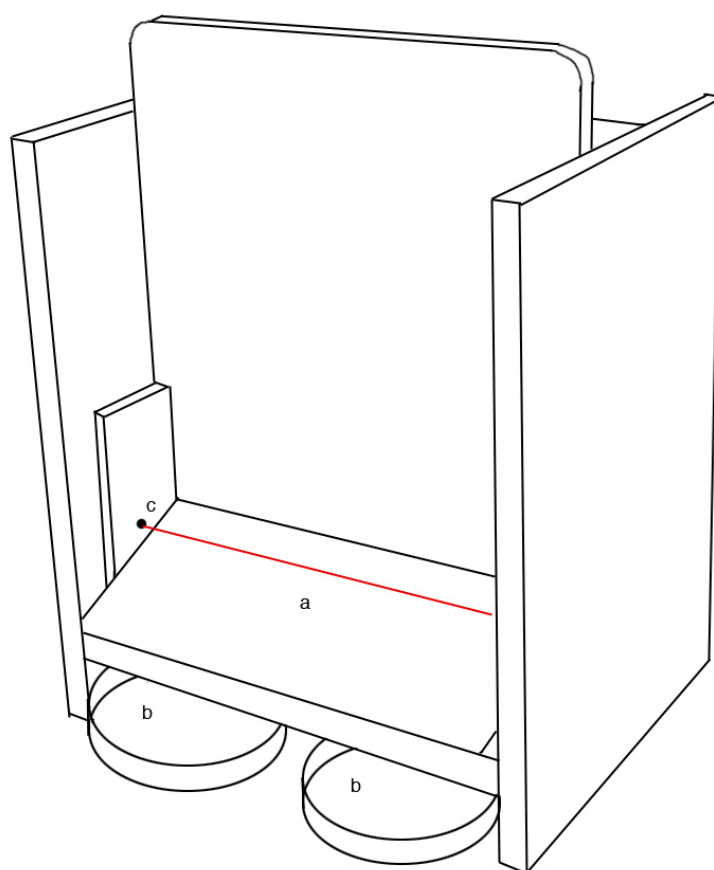

Figure 5.1. A diagram of the apparatus used in the study: a = target, b = milk and water trays, c = photointerruptor shown with a red line.

The apparatus prototype was constructed around an Arduino Uno micro-controller board (SmartProjects, Italy). The Arduino Uno controlled an LCD screen (V1.2 and V1.2: DFRobot, Beijing, China; V2.1: FORDATA ELECTRONIC Co. LTD, China), two peristaltic pumps (SmallPumps, Arlington, Texas, USA; part #

SP200 517), six pin buttons (generic manufacturer, part# SP0710) used to set the training program variables, a power switch (generic manufacturer, part #:SK0960), and an infrared photointerruptor. The photointerruptor consisted of an infrared LED (Osram, Malaysia) and a phototransistor (Vishay, Germany). The flow rate on the pumps was approximately 100 mL/minute. Peristaltic pumps deliver small amounts of liquid by compressing a silicone delivery tube, thus ensuring the tubes were primed to deliver liquid the moment the pump was activated. The pumps were calibrated by measuring the volume of liquid they dispensed in a second. Reservoirs in the form of 500mL intravenous transfusion bags were connected to plastic and silicone tubing, which delivered milk and water to the two pumps. Plastic tubing also delivered liquid from the pumps to two feed trays fixed in front of the target. Each delivery tube was dedicated to delivering either milk or water, and could be configured to deliver fluid into either the left hand tray or the right hand tray, thus allowing milk to be delivered to either side and controlling for any individual's bias to prefer one side over the other. Two auditory protocols were used to control for selective attention to one cue over the other. Protocol A used the lowest tone as the milk tone and the highest as the water tone, and this was reversed in Protocol B.

Four buttons provided a means to select options displayed on the LCD screen. This interface allowed the operator to select the weight class of the dog (0-7kg, 8-27kg, 28-47kg, 48kg+), the auditory protocol, the training phase, and to start the training session. The remaining two buttons activated the two pumps outside of the training program. This was essential for cleaning the tubes and pumps and priming the tubes before the training program began. A speaker volume control dial allowed adjustment of the volume of the tones emitted. The frequencies of auditory tones are shown in **Table 5.2**.

| Protocol A | Protocol B | Frequency (Hz) |
|------------|------------|----------------|
| Milk | Water | 523 |
| P1 | P9 | 600 |
| P2 | P8 | 690 |
| P3 | P7 | 792 |
| P4 | P6 | 910 |
| P5 | P5 | 1046 |
| P6 | P4 | 1201 |

| | | |
|-------|------|------|
| P7 | P3 | 1380 |
| P8 | P2 | 1585 |
| P9 | P1 | 1821 |
| Water | Milk | 2092 |

Table 5.2. Frequency (Hz) of auditory tones used in training and testing. Protocol A is the reverse of Protocol B to control for possible selective attention effects that may influence response latencies.

Habituation

Two coin tosses were used to assign each dog randomly to an auditory protocol and a milk tray side. Dogs were then habituated to the apparatus through a brief habituation program that involved placing a set number (n=14) of small liver treats around the apparatus for the dogs to find and consume. The apparatus was turned on and set to Training Phase 1 (TP1). The tone volume was increased in successive triggering events until the dog's ears came up and forward when the marker tone sounded. At this point, the volume above background noise of the tone was recorded (in decibels) using a sound level meter held within 5cm of the apparatus speaker, and the apparatus volume was set at this level above background noise prior to all interactions the dog had with the apparatus. If dogs did not show an observable response to the tone, the volume was set at maximum for that dog. The milk pump was activated manually when the dog was investigating the apparatus. The dog was allowed to consume the milk delivered to the milk tray and the milk pump was activated manually until the dog moved away from the milk tray or until the pump had run for approximately 7 seconds if the dog did not move away. Any dog that did move away was given approximately 5 seconds to return to the milk tray. If they did not return on their own, dogs were encouraged with verbal coaxing and tapping of the milk tray by the experimenter. This process was repeated until each dog had consumed milk from the tray without a reaction to the sound of the pump for approximately 7 seconds.

Training and Judgement Bias Testing

Dogs were trained in a go/no-go discrimination task where they were required to touch a target with their nose after a tone in order to trigger the delivery of a lactose-free milk reward or water. The tone informed the dog which outcome would be delivered, and thus whether they should go ahead and touch the target

or avoid touching. When dogs showed a significant difference in their response to the two tones, the dog's judgement bias was assessed by presenting 9 new, ambiguous tones that fell between the milk and water tones.

Three training phases were used to train the dogs in the discrimination task. These are summarised in **Table 5.3**. The testing phase was the judgement bias test itself and was the only phase that included ambiguous signals. Training and test sessions lasted no longer than 30-minutes and consisted of four 5-minute training blocks and a 3-minute rest period between each training block. Dogs that had not met success criteria within 30-minutes, were given a subsequent training session within 24 hours.

Training Phase One (TP1)

TP1 trained dogs to touch the target by delivering a reward each time the dog passed through the photointerruptor in front of the target. There was an 8-second block on the photointerruptor after it had been activated so that subsequent triggering did not result in the immediate delivery of further rewards. This prevented the delivery of a double dose of lactose-free milk before the dog had consumed the first reward. Dogs were given at least one full session, after which the criterion in **Table 5.3** was implemented if it had not already been met.

Training Phase Two (TP2)

TP2 trained dogs to move their nose to the target on cue. The cue was an auditory tone (henceforth "milk tone"). The training protocol is shown in **Table 5.3**. Dogs were given one full session on TP2, after which criterion in **Table 5.3** was implemented if it had not already been met. Dogs were excluded from the study if they were not able to meet the criterion for success in three sessions.

Training Phase 2A (TP2A)

The objective of TP2A was to ensure dogs were responding to the tone and not the fixed interval between tones, and to gradually ease dogs into the lower reward rate of TP3 and cognitive bias tests. Criterion in **Table 5.3** was

implemented. Dogs were excluded from the study if they were not able to meet the criterion for success in three sessions.

Training Phase Three (TP3)

The objective was to train dogs to discriminate between the milk tone and a new tone (“water tone”) that signalled that moving the nose to the target would result in the delivery of water instead of milk. Milk and water tones were played such that no more than two of the same tones were played in succession. This was in alignment with other similar cognitive bias studies in animals (Brilot et al. 2010; Doyle, Fisher, et al. 2010a). Tones were followed by a 10-second response window, reward delivery if applicable, 20-second inter-trial interval (ITI), and then the next tone. The criterion for success in TP3 was that dogs demonstrated their discrimination between milk and water tones by touching the target significantly faster after milk tones than after water tones. This was determined by a one-tailed Mann-Whitney U test. Dogs were required to show this discrimination in two successive training sessions or two out of three training sessions. They were given a maximum of 25 sessions on TP3 to achieve the criterion.

Cognitive Bias Test (CBT)

Cognitive bias testing involved the presentation of auditory probes. The apparatus logged the latency of the dog to respond to probe tones by automatically recording when the dog broke the infrared beam of the photointerruptor. The probes were interspersed throughout a regular training session. No more than two tones of the same type were played in a row, with the exception of probe tones, which were played randomly. Each of the 9 probes was presented twice in a cognitive bias test, and each dog was given 3 cognitive bias tests over the space of 2 weeks. A session of TP3 was run in the next session after each cognitive bias test to ensure responses to milk and water tones remained consistent.

| Phase | Training Objective | Structure | Criterion |
|--------------|--|----------------------------------|---|
| TP1 | Dogs to move nose through photointerruptor | 8s block after reward triggered. | Reward trigger rate of at least 8 in 2 of 3 |

| | | | |
|---------------------|---|--|---|
| | beam towards visual target. | | training blocks |
| TP2 | Dogs to move their nose to the target on cue. | Milk tone played, 10s window to respond, 20s Inter-trial Interval (ITI). | 80% successful trigger after tone for 2 of 3 training blocks |
| TP2A | Reduce reinforcement rate | Milk tone played, 10s window to respond, 30s ITI. | 80% successful trigger after tone for 2 of 3 training blocks |
| TP3 | Dogs to discriminate between 2 tones. | Milk or water tone played pseudo-randomly, 10s window to respond, 20s ITI. | Milk latency significantly shorter than water latency (Mann-Whitney U-test) |
| Cognitive Bias Test | Test cognitive bias | 2x9 probes, 15 water, 15 milk presented pseudo-randomly, 20s ITI. | N/A |

Table 5.3. Summary of training phases and cognitive bias testing phase.

Statistics

All statistical analyses were carried out in R, version 2.15 (R Foundation for Statistical Computing). A one-tailed Mann-Whitney U-test with a significance level of $p > 0.05$ was used to test whether dogs were significantly faster to touch the target after milk tones than after water tones. Responses faster than 0.5 seconds were considered too fast to be cognitive and substituted with the mean latency for the corresponding tone in that session if the response was to milk or water tones. If latency was less than 0.5 seconds for a probe tone, that response was excluded. The ‘survival’ package was used to analyse cognitive bias tests using a Cox proportional hazards regression model. This model was chosen as the data were censored at 10 seconds. If dogs had not touched the target within 10 seconds of the tone, their latency was recorded as 10 seconds and marked as censored. The dependent variable in a survival model has two parts: the event indicator and the latency to the event. In this case, the event indicator is touching the target (or reaching the end of the 10-second window without touching the target), and critical latency is the time it takes to touch the target after a tone. The regression model was built using the stepwise method. The terms in the model were tested using the ‘anova’ function, comparing the model containing the new term with a model excluding the new term and retaining the term if there was a significant difference in models.

The results of cognitive bias tests were processed in Mathematica 8 (Wolfram Industries) and interpreted in terms of a mathematical model rather than a

frequentist statistical model. This was to enable us to identify the clear but subtle patterns in the results without depending on measures of statistical significance that may not be appropriate for use with a small sample size such as that reported here. The mathematical model can be defined in words and is shown in **Table 5.3**.

The results from the mathematical model were compared with subjective rankings of the dogs derived from the owners or trainers. Three dog ‘types’ were described in subjective terms based on the response latency data and behavioural data recorded during training and testing. These descriptions are shown in **Table 5.4**. Descriptions were sent to two separate people who knew the dogs well – either living with them or training them. These people were asked to categorise the dogs according to the type that best described them. Categorising dogs as between types was allowed.

| Component | Definition | Interpretation |
|-------------------|---|---|
| Tipping point | The probe number where average latency to respond increases by 100% or more from the average latency of the previous tone in a data table sorted by tone frequency from milk to water. | This provides an indication that the dog has discriminated between tones. Scored by which tone first large increase in latency occurs (1-11, where 1 = milk tone and 11 = water tone). |
| Null response | The proportion of responses with latencies shorter than the average latency for all dogs. | Most useful near tipping point. Gives idea of response rate so average latency will better indicate whether dogs are responding particularly fast when they do respond. |
| Variability score | Fluctuation in average latencies after the tipping point measured by standard deviation/average latency for that tone. This calculation is summed for all tones from the tipping point to give a variability score. | High variability score indicates both quick response and very slow or no response, characteristic of optimistic dogs that either respond fast or not at all. Variation remains low in more pessimistic dogs indicating low levels of response and slow responses. |

Table 5.4. A description of the mathematical model used to interpret latencies.

| Optimism rank | Type | Description of dog's behaviour |
|---------------|------|---|
| 1 | 1 | Dog responds more quickly to signals than other dogs, but may do the ‘wrong’ thing. The dog may not be bothered by an incorrect response or may appear frustrated, but will usually eagerly try again without needing very much encouragement. Dog does not tend to give up easily. |
| 2 | 1-2 | No description given. |

| | | |
|---|-----|---|
| 3 | 2 | Dog responds neither quickly nor slowly to signals and does the right thing on average. When the dog gets something wrong, it may appear disappointed or discouraged, but it will try again with a little coaxing or encouragement. |
| 4 | 2-3 | No description given. |
| 5 | 3 | Dog may prefer not to risk incorrect responses, responding slowly or not at all to signals unless very familiar with the correct response. When the dog gets something wrong, it may appear distressed or be difficult to coax into trying again, or may simply wait passively for a signal it knows. |

Table 5.5. Subjective descriptions of the behaviour of dogs during training and testing. Owners and trainers were asked to place dogs in one of the response categories described, but were allowed to place them between categories to reflect the continuous nature of the descriptions. Dogs were categorised according to their empirical variability scores (optimism rank), giving an indication of how variability scores might relate to how owners and trainers subjectively viewed the dogs' behaviour.

Results

The fate of all dogs in the study is shown in **Table 5.1**. Twenty of the 46 dogs included in the study completed all three cognitive bias tests. The exclusion rate was highest in security dogs (72%, n=11), lower in pet dogs (47%, n=19) and lowest in Assistance Dogs Australia advanced training dogs (33%, n=12). Reasons for exclusion of dogs during the training program included inconsistent or low rates of targeting resulting in a failure to meet the criterion for TP1 and extinction of targeting in later training phases when reinforcement rates decreased. In addition, two dogs appeared to dislike the lactose-free milk, avoiding the milk tray and ignoring attempts to coax them towards it. Dogs that completed training took 9-33 training sessions (Mean=20 ± S.D=6.769) from habituation and TP1 to meeting the criterion at the end of TP3. The twenty dogs that completed cognitive bias tests gave 144 responses each to various cues over the three cognitive bias tests. One dog had data for only two cognitive bias tests as the equipment failed during the second test, resulting in no latency data for that test.

| Term | Regression Coefficient | Standard Error | DF | p-value |
|--------|------------------------|----------------|----|---------|
| Cue P1 | -0.816 | 0.123 | 1 | <0.001 |
| Cue P2 | -1.026 | 0.133 | 1 | <0.001 |
| Cue P3 | -0.816 | 0.123 | 1 | <0.001 |
| Cue P4 | -1.170 | 0.137 | 1 | <0.001 |
| Cue P5 | -1.466 | 0.147 | 1 | <0.001 |
| Cue P6 | -1.287 | 0.139 | 1 | <0.001 |

| | | | | |
|---------------|--------|-------|------|--------|
| Cue P7 | -1.107 | 0.128 | 1 | <0.001 |
| Cue P8 | -1.350 | 0.141 | 1 | <0.001 |
| Cue P9 | -1.749 | 0.158 | 1 | <0.001 |
| Cue Water | -1.352 | 0.064 | 1 | <0.001 |
| Test 2 | -0.007 | 0.059 | 1 | 0.91 |
| Test 3 | -0.213 | 0.059 | 1 | <0.001 |
| Frailty (Dog) | | | 18.6 | <0.001 |

Table 5.6. The statistical output of the final Cox Proportional Hazards regression model for all dogs that complete the cognitive bias testing (n=20). These data describe the difference between the latency of dogs touching the target after the milk tone (reference condition) to each probe tone (CueP1-CueP9) and the water tone (Cue Water). Negative regression coefficients show a reduction in the likelihood of reaching a certain event, in this case, touching the target. Thus, the likelihood of touching the target is significantly less after probe and water tones than after milk tones. The risk of touching the target was not significantly different between trial 1 and 2, but was significantly less in trial 3 than trial 1, indicating a reduced likelihood of touching the target over successive tests. The frailty term (“Dog”) refers to the dog being tested, which is treated in this model as a random effect due to repeated measures on each dog. The term “Dog” also had a significant effect on likelihood of touching the target, meaning that individuals varied significantly in their latency to touch the target.

The Cox’s proportional hazards model showed that there was a significant effect of Dog (DF=18.57, LRT=261.86, P<0.001) and Cue (DF=10.19, LRT=616.9, P<0.001) as well as test number (DF=2.0, LRT=16.45, P<0.001) on latency and the risk of the dog touching the target within the 10-second window. A summary of the terms included in the model is shown in **Table 5.6**. The log of the risk of each dog touching the target within the 10-second window is shown in **Figure 5.2**. This shows that some dogs are far more likely to touch the target after any tone than others. **Figure 5.3** shows how the risk of dogs touching the target differs between cues. There was no significant difference in risk of touching the target between the first and second cognitive bias tests, but there was a significant decrease in the risk of dogs touching the target in the third test compared to the first, indicating that dogs were significantly less likely to touch the target in the third test.

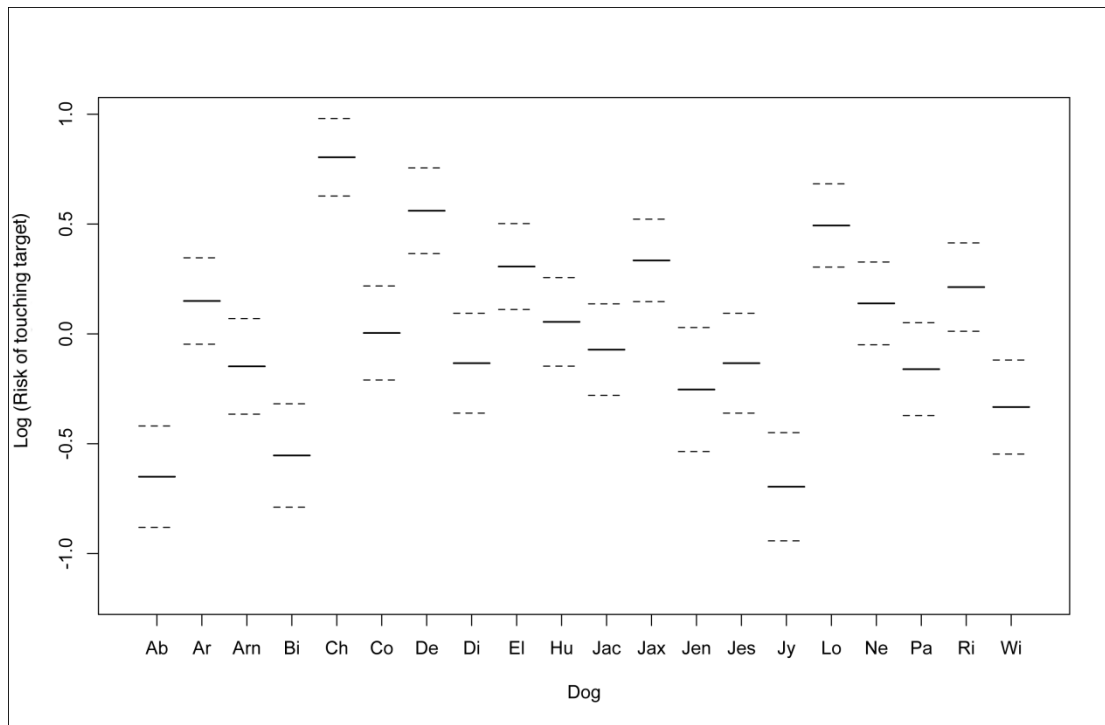

Figure 5.2. The risk of touching the target before the 10-second time out for all cues is shown on the y-axis in a log scale, and individual dogs (n=20) are shown on the x-axis. Standard errors are shown with broken lines. Some dogs are much more likely to touch the target than others. For example, dogs “Ab”, “Bi” and “Jy” have a low likelihood of touching the target regardless of cue, and dogs “Ch”, “De” and “Lo” have a high likelihood of touching the target regardless of cue.

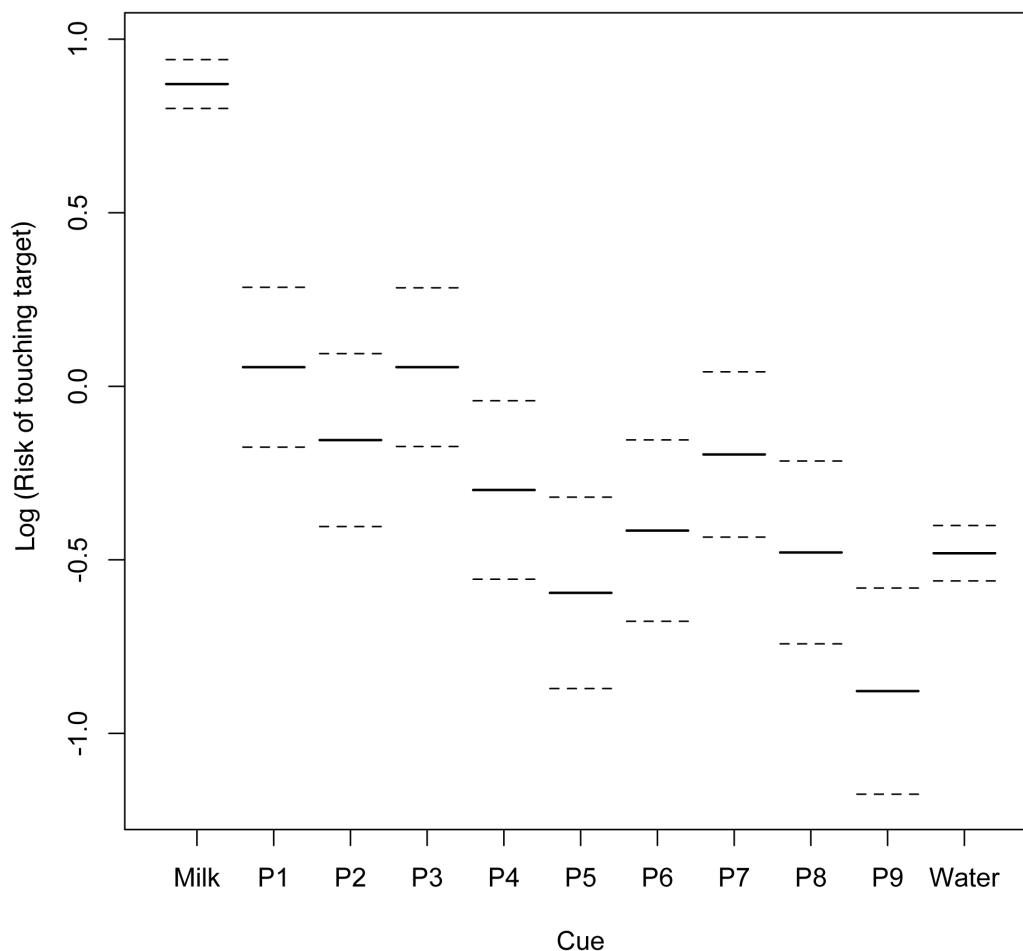

Figure 5.3. The log of the risk of all dogs (n=20) touching the target before the 10-second time out for each cue shown on a log scale on the y-axis with the cues on the x-axis. Standard errors shown with broken lines. Risk is high for the milk tone, showing all dogs were highly likely to touch the target after the milk tone. The lowest risk was for P9, the probe most like water. This shows dogs were unlikely to touch the target after the P9 probe cue. P5, the most ambiguous cue, also showed a low risk of dogs touching the target after this cue.

Response latency graphs were prepared for each dog that completed the cognitive bias tests. Graphs include the average latency for each tone, the standard deviation for each tone, and the null response (log probability of latency longer than the average latency for each tone). Variance scores for each dog that completed the cognitive bias tests are shown in **Table 5.7**.

| Dog | Source | Breed | Sex | Sessions to CBT | Variance score |
|-----|--------|--------------------|-----|-----------------|----------------|
| De | Public | Labrador retriever | M | 13 | 6.47 |
| EI | Public | Labrador retriever | F | 14 | 5.78 |

| | | | | | |
|-----|----------|--------------------------|---|----|--------------------|
| Ch | ADA | Labrador Mix | M | 14 | 5.27 |
| Ri | ADA | Labrador Mix | M | 15 | 5.11 |
| Co | ADA | Golden retriever | M | 17 | 4.41 |
| Ar | Public | Pug X Schnauzer | M | 24 | 3.95 |
| Arn | Security | German shepherd | M | 33 | 3.71 |
| Di | Public | Rhodesian ridgeback | M | 16 | 3.51 |
| Jes | Public | Border collie | F | 15 | 3.51 |
| Lo | Public | Labrador retriever | F | 14 | 3.04 |
| Pa | Security | English springer spaniel | F | 24 | 2.8 |
| Jen | Public | Border collie | F | 28 | 2.69 |
| Jax | ADA | Labrador retriever | M | 20 | 2.05 |
| Jac | Public | Australian cattle dog | M | 17 | 1.47 |
| Wi | ADA | Golden retriever | F | 27 | High latencies |
| Jy | Security | English springer spaniel | F | 28 | High latencies |
| Bi | ADA | Labrador retriever | M | 18 | High latencies |
| Ab | Public | Golden retriever | F | 30 | High latencies |
| Hu | ADA | Labrador retriever | M | 19 | High response rate |
| Ne | ADA | Labrador retriever | F | 9 | High response rate |

Table 5.7. Details of dogs in the study that completed cognitive bias testing, showing source of dog, breed, sex, sessions to learning the discrimination task, and variance score computed by dividing average latency by standard deviation at each cue from the tipping point and summing them. High variance score indicates optimism. Some dogs did not have a clear tipping point, so a variance score could not be calculated. On occasions (n=4), no tipping point could be determined due to overall high latencies such that average latency could not increase by 100% and still be within the 10-second response window. These dogs were categorised pessimistic. Two dogs displayed high response rates across all cues so that average latency did not increase by 100% between two adjacent cues.

Results from dogs with high variance scores, standard deviation approaching mean latencies, and average latencies higher than the null response rate were pooled to show a typical graph for optimistic dogs. Results from dogs with moderate to moderately low variability in latencies, and moderate to high probabilities null responses were pooled to show a typical graph for moderately optimistic, balanced and moderately pessimistic dogs. The dogs with high latencies precluding variability scores and low standard deviation and high rate of null responses were pooled to show a typical graph for dogs that were pessimistic. These graphs are shown in **Figure 5.4** alongside a graph from an optimistic dog to allow a comparison between the individual dog and the optimism category they were assigned to.

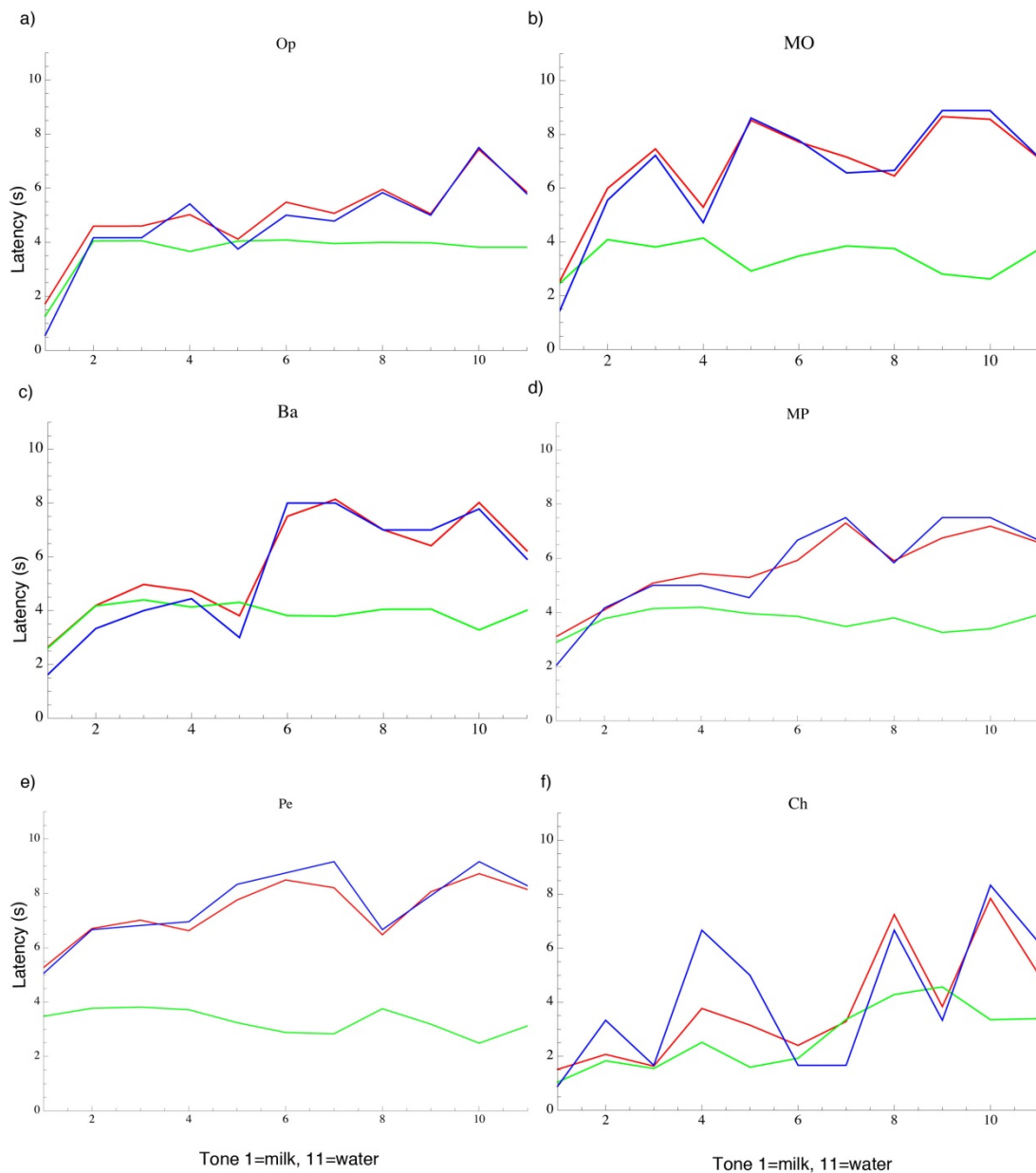

Figure 5.4. A series of graphs showing average latency (red), standard deviation (green) and null response rate, or log (probability of a slower than average response) (blue). In all graphs cue is on the x-axis, with probes arranged in a scale from closest to milk to closest to water. Latency in seconds is shown on the y-axis. Graph a) shows the pooled responses of dogs (n=4) categorised as optimistic (1 on the rating scale in Table 5.8). Characterised by standard deviation approaching the mean latency and average latency higher than the null response rate. This shows the optimistic group responds more quickly more often than other groups. Graph b) shows the pooled responses of dogs (n=4) categorised as moderately optimistic (2 on the rating scale). Standard deviation is lower, and average latencies are higher, but the pattern of average latency is similar to that of optimistic dogs. Graph c) shows pooled responses of dogs (n=3) categorised as balanced (3 on rating scale). Characteristics are similar to those in the moderately optimistic graph, but with more variation at early tones and a low null response rate. Graph d) shows pooled responses of dogs (n=3) categorised as moderately pessimistic (4 on rating scale). Average latency tends to be higher than in other graphs. Graph e) shows the pooled responses of dogs (n=4) categorised as pessimistic, typified by high initial latencies, high null response rate, and low standard deviation. Graph f) shows the responses of a single dog characterised as optimistic.

Tipping point can be seen where average latency increases by 100% or more. Standard deviation approaches mean latency, and the average latency at early tones is lower than the probability of a slower than average response. This means the dog is very fast when it does respond. At later tones the average latency is higher than the proportion of slower than average responses, suggesting the dog is still responding to some tones, but perhaps fewer or more slowly.

All dogs that completed cognitive bias testing had at least one optimism rating from an owner or trainer, and 18 of the 20 dogs had two or more ratings. There were not enough data to perform a statistical analysis on ratings. Results are shown in **Table 5.8**. There was a tendency for owners and trainers to over-estimate the optimism group dogs belonged to in pessimistic, moderately pessimistic dogs, and balanced dogs and to under-estimate the optimism of dogs in moderately optimistic and optimistic groups.

| Dog | Data rating | Owner 1 | Owner 2 | Trainer 1 |
|-----|-------------|-----------|-----------|-----------|
| De | 1 | | | 1 |
| El | 1 | | | 3 |
| Ar | 2 | 1 | | 1 |
| Di | 2 | | | 5 |
| Jes | 3 | 1 | 1 | |
| Lo | 3 | 1 | 3 | 1 |
| Jen | 4 | 5 | 3 | |
| Jac | 4 | 1 | 1 | 2 |
| Ab | 5 | 4 | 3 | 3 |
| | Data rating | Trainer 1 | Trainer 2 | Trainer 3 |
| Ch | 1 | 2 | 1 | |
| Ri | 1 | 2 | 1 | 1 |
| Co | 2 | 2 | 2 | |
| Arn | 2 | 2 | 3 | |
| Pa | 3 | 1 | 2 | |
| Jax | 4 | 1 | 5 | 2 |
| Wi | 5 | 3 | 3 | 4 |
| Jy | 5 | 2 | 1 | |
| Bi | 5 | 3 | 3 | 3 |
| Hu | NA | 2 | 5 | 5 |
| Ne | NA | 1 | 1 | |

Table 5.8. Subjective ratings of dog optimism from owners (n=11) and trainers (n=11) that know the dogs in question. Data rating refers to optimism category assigned based on the dog's variance score. See Table 3 for descriptions of ratings. Ratings are an ordinal scale ranging from 1 = optimistic to 5 = pessimistic.

Discussion

Latency to touch the target differed significantly between probes, with dogs being on average slower to touch the target as probes became more similar to the water tone. This supports the prediction that dogs would respond differentially to signals and that this may correspond to their expectations of

positive and negative outcomes. The differing responses between dogs in this study suggest probes are interpreted differently at an individual dog level. While this seems to support the hypothesis that judgement bias exists in dogs and can be measured objectively, it is unclear how much the differences in responses between dogs can be attributed to affective state. Cognitive biases in humans are sensitive to both short-term changes in an individual's level of anxiety (state anxiety) and long-term, individual difference in an individual's tendency to experience anxiety (trait anxiety, dispositional optimism) (Scheier et al. 1994). There is evidence in animals that some individuals may be inherently more pessimistic than others, for example, stereotyping starlings and macaques are more pessimistic than non-stereotyping or reduced stereotyping conspecifics (Brilot et al. 2010; Bethell et al. 2012), and dogs that show indications of separation-related distress are more pessimistic than dogs that do not (Mendl et al. 2010a). Dogs from Assistance Dogs Australia and security dogs in this study shared the same training and trainers, and the same care and management practices with all the other dogs from their facility, providing largely standardised conditions within each group. Differences in responses between dogs housed at the same facilities may represent a fundamental difference in individual dogs' ability to cope with challenging environments, or an inherent tendency towards optimism or pessimism akin to the trait anxiety described above.

The test number had a significant effect on latency and risk of touching the target. This was analysed to search for a learning effect, which would manifest in dogs responding to fewer probes over time as they learn that probes are not reinforced. This effect has been documented in sheep (Doyle et al. 2010b), but despite being searched for in dogs, has not been identified (Mendl et al. 2010). There was no significant difference between the first and second tests, but there was a significant decline in latency and risk of touching the target in the third test compared to the first. It is possible this effect was not found before in dogs because the method used by Mendl et al. (2010) required fewer trials (21-61 as opposed to at least 9 sessions of 48 trials each in this study) with fewer probes (4 vs 9 in this study), thus not giving dogs (n=24) the opportunity to learn that

probes are unreinforced. A refinement of the methodology presented here by reducing the number of probes may aid in reducing the test effect. However, reducing the number of probes may also reduce the power of detecting fine scale differences in optimism and pessimism between dogs. It was beyond the scope of this study to test the optimal number of probes to present, and this is part of the cognitive bias methodology that has not yet been systematically investigated. The data presented here suggest steps should be taken in future studies to avoid a possible effect of test number.

The statistical model detects broad patterns and differences in the data, but does not provide the means to interpret the data of individual dogs. We have taken a novel approach in interpreting the data of individual dogs using a simple mathematical model in addition to the statistical model. This is a preliminary measure that ideally will be honed with additional data in the future. Examining patterns in mean response latency reveals clear tipping points in most dogs, showing a specific tone where dogs' average latency is longer or the response rate drops sharply from the previous tone. The location of tipping points on the scale between the learned positive and negative tones varied between dogs. This may indicate differences in interpretation of ambiguous tones, suggesting differing judgement biases. An alternative interpretation is that differences in tipping point may reflect learning differences in cue discrimination.

Discrimination was assumed to have occurred when responses to milk tones were significantly faster than responses to water tones for two of three consecutive sessions. Despite this statistical approach to the criterion for testing cognitive bias, it is possible some dogs had different error rates than others for the milk and water tones when their cognitive bias was tested, and this may have influenced their tipping point.

Examining the variability of responses after the tipping point is therefore likely to be most revealing. The tipping point shows that dogs are discriminating between tones and supports the hypothesis that they are interpreting some ambiguous signals as signalling a positive outcome and some as signalling a negative outcome as well as pinpointing where that switch in interpretation

occurs. Standard deviations that approach the mean latency coupled with lower null response rates after the tipping point suggests that the dog is responding to some probe tones that are on average provoking long latencies such as those associated with the water tone with short latencies akin to those associated with the milk tone. This may indicate that either the dog is interpreting a proportion of those probes after the tipping point as signalling a positive outcome or the dog is taking risks by responding to some ambiguous signals in case they are signalling a positive outcome. We propose that either interpretation is a stronger indication of optimism than the tipping point alone. Conversely, standard deviations lower than the average latency and high null response rate after the tipping point indicates the dog is responding to the majority of probes after the tipping point with long latencies or not touching the target at all. This suggests that the dog is either interpreting a greater proportion of probes after the tipping point as signalling a negative outcome or is not willing to risk touching the target in case the ambiguous signal indicated a negative outcome. We propose that either interpretation is a stronger indicator of pessimism than tipping point alone.

The variability score calculated from standard deviation and average latency at each probe after the tipping point gives a single measure of the conditions described in the previous paragraph and thus a possible surrogate for a single optimism score. This gives the opportunity to place dogs on a pessimistic-optimistic scale and compare their degree of optimism with that of other dogs. This represents a more detailed interpretation of judgement bias data than that presented in any other animal studies to date. It is anticipated this mathematical model can be improved on with more data that may allow a weighted algorithm taking into account tipping point and variability score differentially. One potential problem with the current optimism index is that it relies heavily on standard deviation with the assumption that on average, responses after the tipping point are slow or there is no response at all. A dog with very short latencies may show a tipping point, yet also respond very quickly to many probe tones, in which case the standard deviation may be small and the resultant optimism score may be lower than it should be were it truly reflecting optimism

for that dog. As such, including a measure of response rate in the anticipated algorithm may improve the accuracy of the optimism score.

Owners and trainers tended to label optimistic and moderately optimistic dogs as less optimistic than our empirical data suggested, but balanced, moderately pessimistic and pessimistic dogs as more optimistic than the data suggested. This may reflect the subset of the dog population that completed testing. The exclusion rate was high in some groups, so it is unclear how the dogs that were tested compare to the general population. The most logical possibility is that the dogs tested represented a generally more optimistic portion of the population, as many of the excluded dogs were excluded when they failed to persist with the task as the reinforcement rate dropped. Some dogs appeared to find the introduction of water tones and delivery distressing and started to avoid the apparatus once they reached TP3. These observations point to a possible sensitivity to prediction of failures or reward loss and an unwillingness to engage in activities that are only sometimes rewarding. An animal that expects positive outcomes would be expected to readily engage in activities that are only sometimes rewarding and perhaps be more attentive when they are rewarding than when they are not. There was also a difference between dogs in different populations that may alter the experiences of the owners and trainers with dogs in general. For example, the exclusion rate was very high in security dogs and of the three security dogs that did complete the tests none were in the optimistic group. Trainers working with such dogs are likely to label them relative to other dogs in that population, which may be skewed towards pessimism, leading to elevated optimism ratings, as indeed occurred in the two dogs that were categorised (according to the empirical data) as balanced and pessimistic.

There is growing empirical support for the use of judgement bias in objective assessment of affective state in animals (e.g. Bateson et al. 2011; Doyle et al. 2011; Destrez et al. 2012). The focus of this study was not on validating this method as a measure of affective state, and as such the dogs in this study were not subjected to any manipulations intended to alter their affective state, and no measures of affective state were attempted. Therefore, no conclusions can be

drawn from this study regarding the efficacy of judgement bias in measuring affective state in dogs. However, the variation seen in responses from dogs even within the same facilities suggests that personality may play a role in judgement bias results that has not been quantified as yet. Further research in judgement bias in animals should address the possible impact of personality on test results and consider how this may confound future attempts to find a treatment effect in groups of animals assumed to be roughly equal in susceptibility to a given treatment.

Further research into the personality of dogs excluded from the study may reveal patterns in personality traits that may explain why some dogs were not able to complete the training. It is likely a certain level of optimism is necessary for dogs to persist with the self-directed training when reinforcement rates drop as the training progresses. The reinforcement rate was stepped down over three phases during training, which was adequate for many dogs, but may have been too fast or have included too large a drop between phases for other dogs. A study that found that rats were more sensitive to reward loss when their welfare was compromised (Burman, et al. 2008b) may help to explain why dogs failed to meet criteria during training. Although it is difficult to draw parallels between reward loss and a reduction in reinforcement rate, further research into the personality of those dogs being excluded due to extinction of the targeting behaviour may prove insightful.

Conclusions

This study provides proof of concept for the portable, automatic apparatus used to both train dogs and test their cognitive bias. It also lends support to the use of cognitive bias as a tool to objectively measure affective state in dogs. Further research into extinction curves and personality of dogs that were excluded from the study may reveal important information about the affective state of dogs that failed to respond adequately to early training. The addition of a descriptive mathematical model to interpret cognitive bias data offers distinct advantages over a purely statistical interpretation, but may require some development.

Acknowledgements

The authors would like to acknowledge the financial contributions of Black Dog Wear Pty Ltd and Positive Puppies, and the generous help from Positive Puppies, Assistance Dogs Australia, and Schutzhund Security Services in accessing dogs.

| Dog | Source | Breed | Sex/Reproductive status | Protocol | Milk tray side | Phase reached | Reason for exclusion |
|----------|----------|-------------------------|-------------------------|----------|----------------|---------------|---|
| Jazz | Public | Spoodle | F/N | A | R | TP1 | Inconsistency in targeting rate, ear interference |
| Murphy | Public | Whippet x Border collie | M/N | A | R | TP1 | Rate of targeting too low |
| Declan | Public | Labrador retriever | M/N | A | L | CBT | |
| Ellie | Public | Labrador retriever | M/N | A | R | CBT | |
| Oscar | Public | Schnauzer | M/N (implant) | B | R | TP1 | Avoided lactose-free milk |
| Jack | Public | Australian cattle dog | M/N | B | R | CBT | |
| Zack | Public | Maltese cross | M/N | A | R | TP2A | Targeting extinguished |
| Apollo | Public | German shepherd dog | M/N | A | L | Habituation | Avoided lactose-free milk |
| Ellie U | Public | Groodle | F/N | A | R | TP3 | Targeting extinguished |
| Abbie | Public | Golden retriever | F/N | B | L | CBT | |
| Diesel | Public | Groodle | M/N | A | L | TP3 | Targeting extinguished |
| Sinbad | Public | Border collie | M/N | A | R | TP3 | Targeting extinguished |
| Jenna | Public | Border collie | F/N | A | L | CBT | |
| Jesse | Public | Border collie | F/N | A | R | CBT | |
| Lola | Public | Labrador retriever | F/N | B | L | CBT | |
| Diesel T | Public | Rhodesian ridgeback | M/N | B | R | CBT | |
| Archie | Public | Pug x Schnauzer | M/N | B | R | CBT | |
| Chance | ADA | Labrador mix | M/N | A | R | CBT | |
| Hudson | ADA | Labrador retriever | M/N | B | L | CBT | |
| Jaxon | ADA | Labrador retriever | M/N | B | R | CBT | |
| Biscuit | ADA | Labrador retriever | M/E | B | R | CBT | |
| Risky | ADA | Labrador mix | M/N | B | L | CBT | |
| Willow | ADA | Golden retriever | F/N | B | R | CBT | |
| Colonel | ADA | Golden retriever | M/N | B | L | CBT | |
| Penfold | ADA | Golden retriever | M/N | A | L | TP3 | Left facility |
| Paws | ADA | Labrador retriever | M/N | B | R | TP3 | Targeting extinguished |
| Tila | Security | German shepherd dog | F/E | B | L | TP1 | Rate of targeting too low |
| BJ | Security | German shepherd dog | F/E | A | R | TP1 | Rate of targeting too low |
| Arnie | Security | German shepherd dog | M/E | A | L | CBT | |
| Kaiser | Security | German shepherd dog | M/E | A | L | TP2 | Targeting extinguished |

| | | | | | | | |
|--------|----------|--------------------------|-----|---|---|-------------|--------------------------------|
| Shadow | Security | German shepherd dog | F/E | B | R | TP1 | Rate of targeting too low |
| King | Security | German shepherd dog | M/E | B | L | Habituation | Avoided apparatus |
| Jessy | Security | English springer spaniel | F/E | B | R | CBT | |
| Panda | Security | English springer spaniel | F/E | A | R | CBT | |
| Ruby | Security | German shepherd dog | F/E | A | L | TP3 | Targeting extinguished |
| Zena | Security | German shepherd dog | F/E | B | R | TP2 | Targeting extinguished |
| Kato | Security | Belgian Malinois | M/E | B | L | TP2 | Rate of targeting too low |
| Chilli | Public | Belgian Malinois | F/N | A | L | TP1 | Rate of targeting too low |
| Krash | Public | Belgian Malinois | M/N | B | L | TP3 | Targeting extinguished |
| Nellie | ADA | Labrador retriever | F/N | B | R | CBT | |
| Ronnie | ADA | Golden retriever | M/N | A | R | TP3 | Targeting extinguished |
| Buster | ADA | Greyhound | M/N | B | L | TP3 | Failed to learn discrimination |

Table 5.1. A history of dogs in the study, showing their source (ADA=Assistance Dogs Australia), breed, sex (M=male, F=female) and reproductive status (N=neutered, E=entire), the protocol they were assigned to (A=milk tone lowest, B=milk tone highest), the side the milk was dispensed to, the training phase reached before the dog was excluded, and the reason for exclusion. No dogs that reached CBT (cognitive bias tests) were excluded.

Author Contributions

This chapter includes an original paper published by the peer-reviewed journal "Journal of Veterinary Behavior: Clinical Applications and Research". The ideas and development were handled primarily by the candidate and the first author, working within the Faculty of Veterinary Science under the supervision of Dr Paul McGreevy (primary supervisor). The first author, Kitty Cheung, carried out the data collection, analysed data, and wrote the manuscript. The candidate guided the development of the methodology used and assisted in data interpretation and editing the manuscript. Dr McGreevy, as supervisor, provided assistance in project design and in finalising the manuscript prior to publication.

The inclusion of co-authors reflects the fact that the work came from an active collaboration between researchers and acknowledges input into team-based research.

Confirmation of Co-Authorship of Unpublished Work

I, *Melissa Starling*, contributed to the organisation, project design, data collection, statistical data analysis and writing up of the manuscript entitled "***A comparison of uniaxial and triaxial accelerometers for the assessment of physical activity in companion dogs***".

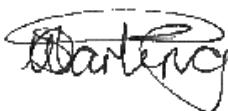

Melissa Starling _____ Date 8 July 2013

I, as a Co-Author, endorse that this level of contribution by myself and the candidate indicated above is appropriate.

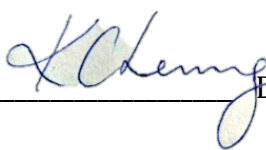

Kitty Cheung _____ Date 02/07/2013



Prof Paul McGreevy _____ Date 25/07/2013

6 A comparison of uniaxial and triaxial accelerometers for the assessment of physical activity in dogs

Kitty W. Cheung, BVSc (Hons); Melissa J. Starling, BSc (Hons), PhD; Paul D. McGreevy, BVSc, PhD, MRCVS, MACVS (Animal Welfare), Cert CABC, Grad 5 Cert Higher Ed.

Faculty of Veterinary Science, University of Sydney, Sydney, NSW 2006, Australia

This paper has been submitted for publication to the *Journal of Veterinary Behavior: Clinical Applications and Research*, 2013.

This manuscript represents a portion of a dissertation submitted by Kitty Cheung to the University of Sydney Faculty of Veterinary Science as fulfillment of the requirements for a Bachelor of Veterinary Science (Honours) degree.

Address correspondence to Kitty Cheung at wche8536@uni.sydney.edu.au

Abstract

The current study compares the outputs of uniaxial and triaxial accelerometers to determine whether uniaxial accelerometers (UA) can be used instead of triaxial accelerometers (TA) in estimating physical activity in domestic dogs (N = 79). The physical activity of the dogs was measured simultaneously by a UA and a TA attached to regular collars under three different conditions: (unstructured activity in the kennels, Kennel Activity; and two structured on-lead activities of different intensities on a designated pathway, Walking and Trotting). The study finds that UA consistently detected significantly more steps. Kennel activity showed the largest differences between the accelerometers and Trotting showed the least. Dogs in the heaviest bodyweight category showed the best correlation between the devices ($r = 0.81$) and the least differences between the accelerometers across the three activities. The limits of agreement were wide in all activities. Significantly higher agreements were associated with lower step counts in Kennel Activity and higher step counts in Walking and Trotting. The results show that these two types of accelerometers cannot be used interchangeably. Confounding factors, such as bodyweight, must be considered in future analysis of accelerometer outputs and selection of devices for different contexts. Optimal interpretation of objectively measured physical activity is paramount in supporting future dog fitness, health and welfare studies.

Keywords

Dog; physical activity; uniaxial; triaxial; accelerometer

Introduction

Physical activity (PA) is an important variable in studies of medical conditions. Debilitating diseases, such as cardiac diseases, obesity and osteoarthritis, result in reduction of mobility (Freeman et al. 2005; Brown et al. 2007; Brown et al. 2010b; Warren et al. 2011; Weber 2011; Brown et al. 2010a), while other conditions, such as pruritus and separation anxiety, are often accompanied by an increase in the activity level (Nuttall & McEwan 2006; Plant 2008; Konok et al. 2011). Measuring activity levels objectively is challenging due to the complex dynamics of physical movements (Weber 2011). Most movements comprise acceleration in multiple directions and can also vary in frequency and intensity. This explains why studies to assess the efficacy of interventions targeting mobility disorders frequently rely on qualitative data. In practice, such data are generally reported by the patient's owner. While owner reports are a convenient assessment tool, they are subjective and individuals have a tendency to overestimate the time spent in PA (Weber 2011). Overcoming owner subjectivity and observer error when assessing activity demands an easy, reliable, objective measure that clinicians can interpret.

In the context of human healthcare, pedometers have become a popular activity monitor. While pedometers measure only the number of steps taken, accelerometers use piezoelectric sensors to measure the frequency, intensity and duration of PA. Accelerometers also have extended internal memory, permitting researchers to perform detailed objective studies over longer periods while minimizing human intervention in data collection.

The application of accelerometers to measure PA in dogs is still in its early stages. Nuttall and McEwan (2006) and Plant (2008) have shown that accelerometers can reliably differentiate pruritic from healthy dogs based on PA. Brown et al. (2010b) demonstrated the use of accelerometers in documenting the impact of therapeutic intervention in dogs with osteoarthritis. The magnitude of PA and subsequent accelerometer output is affected by a range of factors, such as the dog's age, body condition score, bodyweight, body

conformation, as well as the day of the week on which the measurements are taken (Dow et al. 2009; Brown et al. 2010b; Warren et al. 2011; Weber 2011). There are two main types of accelerometers, triaxial accelerometers (TA) and uniaxial accelerometers (UA). TA detect movement in three dimensions and UA are sensitive to movement in only one plane, usually the vertical. Compared to TA, UA are more similar to pedometers and lack memory capacity, but are usually in the region of 20 times cheaper. They are favored over pedometers due to their ability to filter out incidental movement and maintain accuracy at a tilted angle (Crouter et al. 2005).

The accelerometers have been validated in laboratory settings and on humans in everyday situations (Le-Masurier & Tudor-Locke 2003; Esliger & Tremblay 2006; Corder et al. 2007; Oliver et al. 2011). Few validation studies have been reported performed in canine subjects. Hansen et al. (2007) validated canine accelerometer data against computerized videography in a laboratory setting. Their study found that TA 'provided acceptable correlation with videographic measurements of movement and mobility'. The validity and reliability of UA in canine subjects have yet to be determined due to their recent market emergence. It is therefore of interest to know whether these cheaper UA are as accurate as the more costly TA.

The objective of our investigation was to quantify the physical activity of dogs using uniaxial and triaxial accelerometers in order to compare their outputs and thus determine whether UA can be used instead of, TA and relate these measures to bodyweight, which is one of the proposed confounding factors (Brown et al. 2010b). We hypothesized that:

- a) The devices are more comparable in structured activities rather than during sedentary behavior (e.g., in a kennel), and
- b) A dog's bodyweight affects the inter-device difference.

Material and methods

The protocols used in this study were approved by the Animal Ethics Committee of the University of Sydney (Approval number N00/11-2010/3/5407). Written consent was obtained from the dogs' carers prior to the commencement of the study.

Study participants

Companion dogs (n = 90) from Renbury Farm shelter (Austral, NSW, Australia) were enrolled into the study. On the basis of physical examination by a veterinarian, all participating dogs were deemed healthy and free of any apparent orthopedic disorders and neurological deficits. Ten dogs were subsequently excluded from the study due to various behavioural issues. They included excessive barking, aggression and fear aggression towards the researchers. After the devices were mounted onto candidate dogs' collars, a 5-minute adjustment period was allocated during which the potential participants were observed prior to data collection. One dog did not tolerate the device (e.g., showed excessive head shaking or neck scratching) during this period and was excluded from the study. As a result, a total of 79 dogs participated in our study. Mixed-breed dogs represented a significant proportion of the sample population. Most recruited dogs were estimated to be over 12 months old.

Bodyweight comparison

To ensure effective assessment of the role, if any, of bodyweight in PA measurement, a minimum of 15 dogs was arranged into each of the following weight ranges: light (<10kg), medium (10 to 25kg), and heavy (>25kg). Bodyweights (in kg) were measured using a standard walk-on scale.

Triaxial accelerometers (TA)

Five TA (Actical Accelerometer, Mini-Mitter Inc., Bend, Oregon) measuring 37 x 29 x 9mm and weighing 17g with battery, were used in this study. To date, Actical monitors have been the most frequently used brand of TA in canine clinical studies (Hansen et al. 2007; Dow et al. 2009; Brown, Boston, et al. 2010a; Michel & Brown 2011). Consequently, we chose them as the representative of the TA in the present study to facilitate comparison with the available literature

on the device. These omni-directional piezoelectric devices use a horizontal cantilevered beam that compresses a piezoelectric particle upon movement. The movement creates a change in velocity (per unit time) and generates a voltage in the sensor proportional to the acceleration, which is subsequently modified and converted into a digital value (Hansen et al. 2007). For each measurement period, the digital value generated is compared with the baseline value, which filters out constant acceleration, such as that created by gravity. The difference between the baseline and acceleration values can then be used to create a raw activity value specific for each measurement period. Although the device is capable of detecting motion in all directions, it is most sensitive in the direction parallel to its longest dimension (Hansen et al. 2007). The activity detected in the vertical plane contributed most to the overall step counts as a result of this mechanical bias. Through use of the standard software (Actical v2.1, Mini-Mitter Inc., Bend, Oregon) that accompanies these commercial devices when purchased, the raw activity value was converted to the simple step count used in our study. For the purpose of our study, the measurement period was set at 1 minute to allow data collection of the two 3-minute activities. The time stamp on each accelerometer was automatically synchronized with the clock in the computer.

Uniaxial accelerometers (UA)

Five UA (G-Sensor 2026 Accelerometer, Pedometers Australia; <http://www.pedometeraustralia.com>) measuring 61 x 32 x 12mm and weighing 27g with battery, were used in this study. They rely on a similar mechanism to the TA, using piezoelectric sensors. However, unlike TA, UA can register motion in only one plane, so the intensity or pattern of the movement was not measured. The UA selected for the present study was one of the most affordable among the range of UA available on the market. It had an in-built function of displaying on the screen only if more than 5 consecutive movements were recorded. This helped to eliminate incidental movement by the subject, such as a sneeze or a sudden head lift. It meant that if, for instance, a dog took only 5 steps, a total activity count of zero would be displayed, whereas if it took 6 or more steps consecutively, the actual measured number of steps would be displayed on the

screen. In contrast to the logged output of the TA, the output of the UA was recorded manually by the researcher.

Positioning of the accelerometers

The accelerometers were strapped to the collar around the dog's neck. The TA was embedded in a tailored casing that was secured onto a purpose-made collar, with the UA being clipped onto the outer surface of this casing. This arrangement optimized the comparability of the devices as they were mounted at approximately the same location on each dog.

Study protocol

All field experiments were conducted during daylight hours between August 2011 and January 2012. Each dog underwent a series of three standardized activities. Approximately 5-10 minutes was allocated between each activity for the dogs to recover before commencing the next activity. The heart rate, measured by auscultation before the next activity, was compared with the heart rate prior to the start of activities to confirm adequate recovery was achieved between the activities. The study consisted of three activities.

Activity 1: Unstructured activity (Kennel Activity)

Kennel Activity was defined as a 1-hour period in the kennels during which the animals were allowed to express unstructured, natural behavior. We avoided sampling during peaks of arousal such as feeding time. The dogs were observed from outside the kennels to ensure that the devices remained in the appropriate position. Due to the regulations of the shelter, the dogs were housed in 2 different sized kennels, according to their approximate body size. Medium-to-heavy dogs were allocated to the larger cages (1.1x3.7m), while the rest were allocated to the smaller cages (1.1x2.2m). The researcher entered the kennels 1 minute prior to the completion of the activity to record the UA measurement to within a 1 second of the time on the TA. The activities were timed using a digital watch, which was manually synchronized to the clock of the computer with a maximum time difference of 1 second. Immediately prior to the start of each

activity, the participants were required to remain stationary while the researcher reset the UA. Once the period of the activity had commenced, they were allowed to move. This protocol maximized the synchronization between the UA and TA records of the start and finish times of each activity.

Activity 2 & 3: Structured activities (Walking and Trotting)

The first structured activity (Walking) involved a 3-minute leashed walk for laps on a designated flat, level concrete pathway. This outdoor pathway was 21.5 × 1.1m. Dogs were unable to stray from the pathway due to the proximity of the adjacent buildings on either side of the pathway. The second structured activity (Trotting) involved a 3-minute leashed activity to resemble trotting as closely as possible, and was conducted on the same pathway as Walking. For the purpose of this study, we defined trotting as a rhythmic two-beat diagonal gait in which the feet of diagonal limbs land together.

Statistical analysis

The raw outputs from TA were downloaded using Actical v2.1. Non-parametric methods of statistical analysis were used. Descriptive statistics were calculated for each activity. The continuous variable (step counts) was tabulated into median and inter-quartile range, and the categorical variables (number of participants and bodyweight) were summarized as frequencies.

In each activity, the coefficient of variation was calculated for each activity by dividing the standard deviation of (UA-TA) by $(UA + TA)/2 \times 100$, as defined by a similar human study that compared two different accelerometers (Paul et al. 2007). A Wilcoxon signed-rank test was performed to detect any significant difference in PA measurement between the UA and TA within each activity. Spearman correlation coefficients were calculated to test for any association between the step counts recorded by the UA and the TA. Spearman correlations were also calculated to compare the strength of the relationship of the UA and TA between the bodyweight categories. The percentage difference of the step counts between UA and TA was compared between all activities and bodyweight

categories, using a Kruskal-Wallis test. Any significant relationships identified were then analyzed with a Mann Whitney U test.

The level of agreement between the two accelerometers was evaluated in each activity with the use of a plot of the differences of the step counts derived from both devices as a function of the mean step counts of both devices (Bland & Altman 2010). Although the distribution of both measures was not normal, the inter-device differences matched the criteria of Bland-Altman agreement as they did not follow any systemic pattern over the range of measurement.

Consequently, the data did not need to be log-transformed prior to Bland-Altman analysis. Mean difference (bias) in the Bland-Altman analysis represented the systemic error between the 2 methods. The upper and lower 95% limits of agreement (LOA) were calculated as bias \pm 2 SD.

The majority of the statistical analyses were performed using a commercially available statistical software package (SPSS v20.0, IBM Corp, Armonk, New York). For all comparisons, values of $P < 0.05$ were considered significant.

Results

After the commencement of the activities, various dogs in each activity were further excluded from the final data. They were removed due to reasons such as technical failure (e.g., detachment of the UA from the TA collar or devices running out of battery power) and behavioral issues (such as reluctance to exercise outdoors, excessive head shaking or barking). As a result, 76 dogs in Kennel Activity, 63 dogs in Walking, and 63 dogs in Trotting of the initial 79 dogs contributed to the final data collection. There were 41% mixed breed and 59% purebred dogs.

Statistical analysis was performed on PA measurements recorded over a total of 4560 minutes in the unstructured activity and 390 minutes in the structured activities combined.

Between-activities and within-activity variability

The descriptive statistics of the PA estimates measured by the UA and TA are presented in Table 6.1. The coefficient of variation (CV) demonstrated a much larger inter-device variability in PA recorded between unstructured activity and structured activities, as compared to between the two structured activities. The measure of PA from the UA was significantly higher than the TA in all activities ($Z = -4.67, -6.75$ and -6.32 for Kennel Activity, Walking and Trotting respectively, and overall $Z = -9.50$; $P < 0.001$ for all calculations).

| | No. of participants | Median (step count) | Interquartile range (step count) | CV (%) |
|-----------------|---------------------|---------------------|----------------------------------|--------|
| Kennel Activity | 76 | | | 76.2 |
| UA | | 688 | 358-1258 | |
| TA | | 397* | 198-863 | |
| Walking | 67 | | | 27.3 |
| UA | | 294 | 270-326 | |
| TA | | 201* | 168-261 | |
| Trotting | 63 | | | 26.1 |
| UA | | 351 | 314-385 | |
| TA | | 275* | 195-329 | |

Table 6.1. Descriptive data on the step counts produced by the study participants (n=76). In all activities, uniaxial accelerometers (UA) consistently recorded higher step counts than triaxial accelerometers (TA).

*statistically significant, Wilcoxon signed-rank test ($P < 0.001$)

UA step counts were significantly correlated to TA step counts only in the unstructured activity (Table 6.2). The correlation was not statistically significant in the structured activities.

| | Correlation coefficient | 95% confidence intervals | P-value |
|-----------------|-------------------------|--------------------------|---------|
| Kennel Activity | 0.75 | 0.63 – 0.83 | <0.001 |
| Walking | 0.11 | -0.14 – 0.34 | 0.38 |
| Trotting | 0.28 | 0.04 – 0.50 | 0.26 |

Table 6.2. Spearman correlation coefficients of the step counts produced by triaxial accelerometers and uniaxial accelerometers across three types of activity. A significant correlation was only found in Kennel Activity.

Bodyweight comparison

A significantly positive correlation of the PA measurement between the devices existed within all bodyweight categories (Table 6.3). The correlation could explain most of the inter-device difference in heavyweight dogs ($r = 0.81$) and slightly less in middleweight dogs ($r = 0.71$). However, only approximately 54% of the measurements collected from lightweight dogs were significantly correlated.

| | Correlation coefficient | 95% confidence intervals | <i>P</i> -value |
|--------|-------------------------|--------------------------|-----------------|
| Light | 0.54 | 0.36 – 0.68 | <0.001 |
| Medium | 0.71 | 0.54 – 0.82 | <0.001 |
| Heavy | 0.81 | 0.71 – 0.87 | <0.001 |

Table 6.3. Spearman correlation coefficients of the step counts produced by triaxial accelerometers and uniaxial accelerometers across three categories of bodyweight. UA and TA were significantly correlated in all bodyweight groups, with the highest correlation found in the heavyweight group.

CV of the bodyweight within each activity is plotted in Figure 6.1. The step counts were not statistically different between the bodyweight groups. Heavyweight dogs were found to have the lowest variability in inter-device difference across all three activities. The median CV of the heavyweight dogs was significantly different to both light and middleweight dogs in Kennel Activity and Trotting (P value ranges from <0.001 to 0.03), but was significantly different to only the middleweight dogs in Walking ($P = <0.001$).

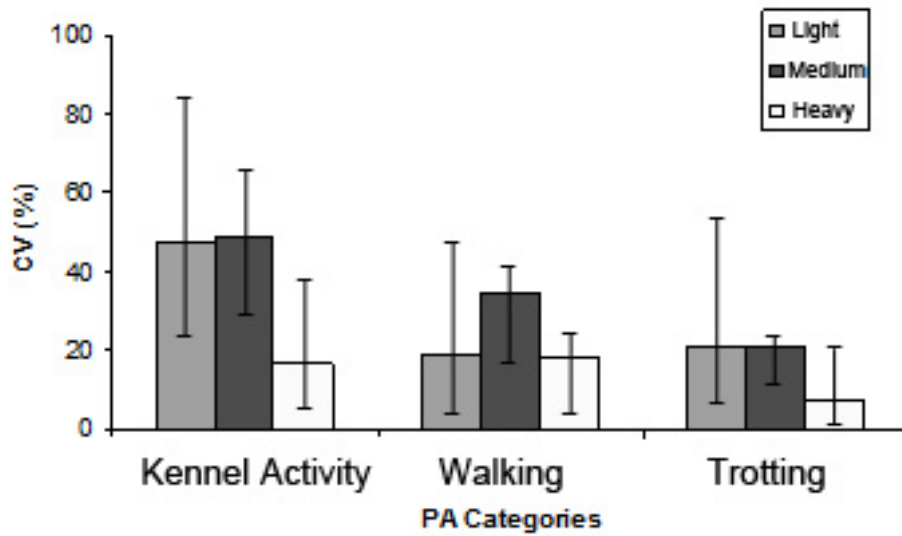
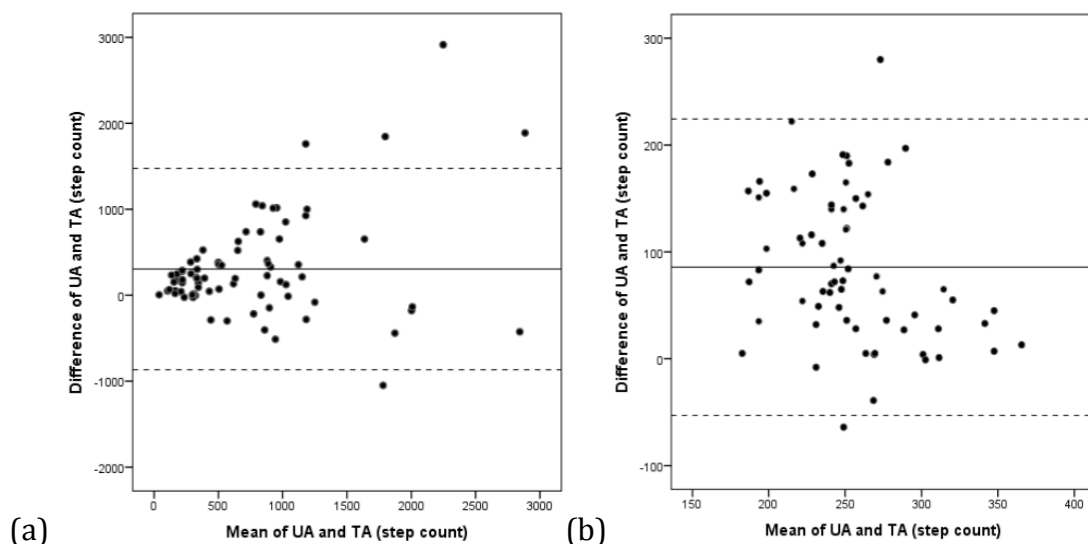

Figure 6.1. The comparison of the coefficient of variation (CV) between the bodyweight groups in each of the activities that were conducted on 76 dogs. The vertical lines represent the 25th and 75th percentiles of the CV of each bodyweight group. The CV of the heavyweight dogs was significantly lower than the lightweight and middleweight dogs in Kennel Activity ($P < 0.001$) and Trotting ($P = 0.03$), and the middleweight dogs in Walking ($P < 0.001$).

Agreement between UA and TA output within each activity

The Bland-Altman plots of agreement and the associated 95% LOA for the UA step count relative to the TA step counts in each category are illustrated in Figure 6.2.



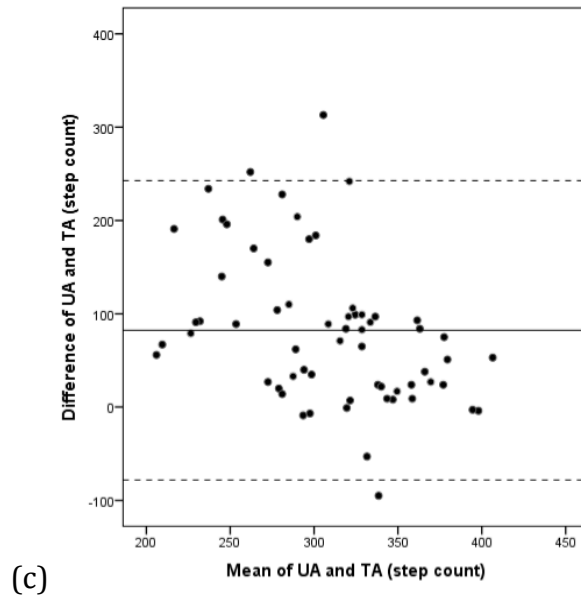

Figure 6.2. Bland-Altman plots demonstrating the bias (mean difference) and variability (95% level of agreement [LOA]) of the physical activity measurements of two accelerometers (TA, Triaxial accelerometers and UA, Uniaxial accelerometers) in 76 dogs during Kennel Activity (a), Walking (b) and Trotting (c). Data with 95% LOA are marked with a dotted line and mean difference of UA and TA marked with a solid line.

Although significant correlations have been found in Kennel Activity and Trotting, the 95% LOA were broad in all activities. Their percentage differences relative to UA-determined step counts ranged from 214.39% to -126.07% (width 340.46%) in Kennel Activity, 76.32% to -18.03% (width 94.35%) in Walking and 69.17% to -22.29% (width 91.46%) in Trotting. The mean percentage differences relative to UA-determined step counts varied from 23.44% in Trotting to 44.16% in Kennel Activity. Kennel Activity had the highest number of measurements occurring outside the 95% LOA, whereas Walking had the least. The highest agreement was associated with lower step counts in unstructured activity. Conversely, the structured activities had the highest agreements with higher step counts. Graphically, Bland-Altman analysis also demonstrated that UA produced consistently higher step counts across the three activities.

Discussion

This is the first study, to the authors' knowledge, that compares the PA measurements of UA with TA in dogs. It found that these accelerometers differed significantly in the number of step counts detected, demonstrating that their data may not be used interchangeably. Although both devices were designed to measure PA, differences in the inbuilt sensors, conversion and amplification factors affected the accumulated step counts (Paul et al., 2007). Data from these devices were most comparable in the structured activities (Walking and Trotting). The heavyweight dogs produced the most consistent differences in the PA measurements between the two types of accelerometer.

Triaxial accelerometry is theoretically capable of capturing more movements than uniaxial accelerometry. However, most uniaxial and triaxial accelerometer comparisons in human studies and laboratory settings have reported that the two species of accelerometers yield relatively comparable results (Corder et al. 2007; Welk et al. 2012). The present study does not offer an explanation for this phenomenon. Conversely, Paul et al (2007), studying humans, compared a different brand of UA with the same brand of TA as our study. They found that UA had consistently detected significantly more PA daily than TA. Our study confirms the findings of Paul et al (2007) that certain brands of UA tend to produce higher PA measurements than Actical monitors.

The UA used in this study has an inbuilt feature to display the step counts only when 6 or more steps were detected consecutively. The purpose of this function was to eliminate the incidental vibrations encountered by human users, such as during a bumpy car ride, but the degree of impact of this function on clinical studies remains unknown. Theoretically, this function could have produced lower step counts than those detected by the UA, therefore compromising the results of our study by generating erroneously low step counts with the UA. We were therefore surprised to find a significant difference in the opposite direction. The strength of correlation between UA and TA outputs differed between the three activities, as did the number of step counts. This suggests the sensitivity of one or both of the devices changed according to the type of activity undertaken. One study has found that the activity counts produced by Actical monitors had

similar correlation with the computer-assisted videography measurement of Beagles in a kennel environment, indicating that there was a robust relationship between Actical monitors and different types of movement (Hansen et al. 2007). Other laboratory studies concluded that Actical monitors were reliable but their variability was negatively associated with acceleration (Esliger & Tremblay 2006). This relationship cannot be directly verified in the present study as we would require an additional objective measurement of the step counts to determine the variability of the devices. Confirming the variability of the devices would also help us to investigate the origins of the lower correlation in the structured activities as compared to unstructured activity within the kennels.

Heavyweight dogs consistently produced the lowest inter-device difference in all the activities, which suggested that the bodyweight of the dogs could potentially influence the PA detection by the accelerometers. A similar result was reported by Brown et al. (2010b), who found that an increase in body weight is correlated to a reduction in activity counts by Actical monitors during controlled activities. In the absence of morphometrics for each of the dogs in the current cohort, we cannot rule out the possibility that body conformation, rather than simple bodyweight, acted as a confounding factor in our results. One would expect larger-framed dogs to show larger limb movements that would be characterized by accelerations of a magnitude that could be more readily detected by the accelerometers. However, several aspects of canine conformation, such as limb and body length, have been reported elsewhere to have no significant effect upon the activity counts (Brown et al. 2010b).

Bland-Altman analysis generated interesting results regarding the agreement of the devices. The 95% LOA were too wide for the two devices to be considered in agreement with each other, suggesting that the step counts cannot be readily interchanged between UA and TA. There is no published guideline for the acceptable difference between various accelerometers, thus our conclusion that UA and TA cannot be used interchangeably was based on the Bland-Altman analysis of the agreement. It is also clear from Figure 2 that higher agreement was associated with lower step counts in Kennel Activity and higher step counts

in the structured activities. One possible explanation of this finding in Kennel Activity might be explained by the 5 dogs (7%) for which the inter-device difference lay outside the LOA. These dogs coincidentally produced the highest step counts within this activity, which suggested that they were either extraordinarily active, or were performing some non-locomotory activities, such as barking, chewing their body or panting. These activities might not be readily detected by one species of accelerometer due to a higher threshold in its sensitivity. On the other hand, higher step counts might indicate that the participants were more focused on performing the structured activities and had diminished opportunities to show other elements of their behavior repertoire; consequently the accelerometers were most in agreement with higher step counts. These hypotheses can be tested in future studies using videography installed in the kennel to record each dog's behavior during the measurement periods.

The inclusion of unstructured and structured activities in the current study allowed us to compare the performance of the UA and TA during unfettered behavior and structured behavior. However, this study did not replicate the normal roaming environment of a domestic dog or the extensive range of activities that occurs in the general population. Therefore, future research should aim to evaluate the performance of different accelerometers on PA measurement of dogs in their home environments. Moreover, we acknowledge that because the structured activities were not completely controlled, the dogs were able to perform a small amount of additional behavior, such as sniffing the ground, while walking. Some variation in performing the activities could potentially affect a portion of the results reported here. However, the study design remains valid as our purpose with the structured activities was to observe whether the change in the activity level (Walking versus Trotting) affects comparability between PA outputs of the two different accelerometers. The results of the current study suggest that the PA measurement in dogs by UA is not directly comparable to TA. Since comparisons of accelerometry tools have not previously been reported in dogs, validation of UA for the measurement of activities in dogs under Kennel Activity conditions, for example, by comparison

with a video record, is recommended to complement the findings presented here. A conversion equation to correct the outputs of the devices may emerge once UA are validated and confounding factors are identified. The prospect of a conversion equation is plausible, as Paul et al. (2007) has successfully compared the converted output of UA and TA in humans. Moreover, with the conversion equation, we wondered whether mounting 3 uniaxial accelerometers on different planes may provide a more comparable result to triaxial accelerometers, as both types of device would then detect an equal number of planes with this set up. This hypothesis has not been tested in human or animal studies, but it may be of interest to future researchers.

Another potential direction for future studies would be to continue evaluating the role of both UA and TA in fitness programs for dogs in sport and in the management of dogs with health concerns. Modern lifestyles result in many pet owners spending significant periods away from home. Without direct supervision, the use of objective accelerometers may provide good monitoring tools for pets with ongoing health issues that interfere with mobility. For this research stream to develop, more studies are needed to interpret objectively monitored PA and to create guidelines for the acceptable deployment of various types of accelerometers.

Acknowledgements

The authors would like to thank A/Prof. Peter Thomson and Dr Navneet Dhand for statistical assistance, and Dr Lisa Tomkins for help in our initial deployment of the Actical monitors. We are also very grateful to Renbury Farm shelter for allowing us access to their dogs.

Abbreviations

| | |
|------------|--------------------------|
| <i>CV</i> | Coefficient of variation |
| <i>LOA</i> | Limits of agreement |
| <i>PA</i> | Physical activity |
| <i>TA</i> | Triaxial accelerometer |
| <i>UA</i> | Uniaxial accelerometer |

Author Contributions

The following chapter includes an original paper published by the peer-reviewed journal "Animals". The ideas, development, and preparation of the manuscript were all the primary responsibility of the candidate, working within the Faculty of Veterinary Science under the supervision of Dr Paul McGreevy (primary supervisor) and, Dr Nicholas Branson (associate supervisor). Dr McGreevy and Dr Branson both assisted in the development of the manuscript and associated graphs in their roles as supervisors. Denis Cody assisted in graph generation and in preparing the relevant sections of the manuscript.

The inclusion of co-authors reflects the fact that the work came from an active collaboration between researchers and acknowledges input into team-based research.

Confirmation of Co-Authorship of Published Work

I, *Melissa Starling*, contributed to the ideas, development and preparation of the manuscript entitled "***Conceptualising the impact of arousal and affective state on training outcomes of operant conditioning***".

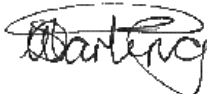
Melissa Starling  Date 2nd August 2013

I, as a Co-Author, endorse that this level of contribution by myself and the candidate indicated above is appropriate.

Dr Nicholas Branson  Date 25.7.13

Denis Cody  Date 2.8.13

Dr Paul McGreevy  Date 20.7.13

7 Conceptualising the impact of arousal and affective state on training outcomes of operant conditioning

Melissa J. Starling ^{1,*}, Nicholas Branson ², Denis Cody ³ and Paul D. McGreevy ¹

¹ Faculty of Veterinary Science, University of Sydney, NSW, Australia; E-Mails: author1@email

² Deakin Research, Deakin University, VIC, Australia; E-Mails: author2@email

³ Indice Ecotech Pty Ltd, VIC, Australia

This paper has been published in *Animals*, 2013, 3, 300-317

Simple Summary: This article discusses the impacts of arousal and emotional state on training animals using methods based on reward and punishment. Three-dimensional graphs are provided to offer a visual means to illustrate how arousal and emotional state may influence the effectiveness of reward and punishment depending on the behaviour being trained. Dogs and horses are used to illustrate this with reference to commonly trained behaviours in a predatory and a prey animal.

Abstract: Animal training relies heavily on an understanding of species-specific behaviour as it integrates with operant conditioning principles. Following on from recent studies showing that affective states and arousal levels may correlate with behavioural outcomes, we explore the contribution of both affective state and arousal in behavioural responses to operant conditioning. This paper provides a framework for assessing how affective state and arousal may influence the efficacy of operant training methods. It provides a series of three-dimensional conceptual graphs as exemplars to describing putative influences of both affective state and arousal on the likelihood of dogs and horses performing commonly desired behaviours. These graphs are referred to as response landscapes, and they highlight the flexibility available for improving training efficacy and the likely need for different approaches to suit animals in different affective states and at various levels of arousal. Knowledge gaps are discussed and suggestions made for bridging them.

Keywords: arousal; affective state; operant conditioning; animal training; dogs; horses

Introduction

Trained animals are important contributors to work, sport and recreation. As a leading example, domestic dogs (*Canis familiaris*) have a long association with humans that depends largely on our ability to train them. This training ranges from conditioning simple behaviours that optimise sharing a living space with

them to highly specific and complex behavioural sequences that capitalise on the abilities of dogs that we lack, such as speed, agility and a keen sense of smell. Current approaches for training animals are generally anchored in operant conditioning (McGreevy & Boakes 2007). The science behind operant conditioning, while detailed, sound, and very useful, is not a complete model, missing biological and psychological principles beyond the behavioural principles developed that may help further our understanding of the origins of behaviour (Panksepp 1998, p.23). For example, in dogs, it may fail to fully explain why one dog may relate more to one trainer than another, despite both trainers using the same operant techniques (McGreevy et al. 2012). It has long been held that behavioural output is also a product of affect, which comprises two components, arousal and emotional valence (Barrett et al. 2007; Russell & Bullock 1985). Unlike operant conditioning outcomes, arousal and emotional valence are more challenging to quantify. Arousal refers to physiological and psychological activation into a state of general wakefulness or attention (Moruzzi 1969). In non-human animals, it is generally measured by physiological signs known to increase in association with arousal, such as tachycardia, hypotension and pupil dilation (Bradley et al. 2008; Jones 2003) and changes in skin-conductance levels (Williams et al. 2001).

Arousal was first conceptualised as a generalised construct, in which a single dimension accounts for arousal in all circumstances. The Yerkes-Dodson Law is the most widely recognised general arousal construct (Yerkes & Dodson 1908). The arousal level associated with the highest performance on a task is considered the optimal arousal level for that task (Eysenck 1982). Where arousal is below the optimal level, under-stimulation may result in slow performance or lack of interest in performing at all. Where arousal is above the optimal level, performance suffers due to narrowing of focus so that only a few cues can be attended to (see Hanoch 2004 for review and discussion). Optimal arousal levels are considered to be task-specific, such that more challenging tasks are performed more successfully at low arousal levels and simpler tasks can be performed successfully at higher arousal levels. This has been described as the inverted-U relationship (Mair et al. 2011).

Emotional valence captures the notion of positive and negative affective states. Intuitively, one might predict these to have an immediate impact on an animal's likelihood of responding to learned stimuli. However, it has only recently been possible to consider the contribution of emotional valence to training outcomes as advances in the area of animal cognition have provided possible indicators of both positive and negative affective states. The most promising of these indicators may be cognitive bias, which refers to the tendency for affective state to influence cognitive processes (Mendl et al. 2009). Recent animal studies have found that one class of cognitive biases, known as judgment or expectation bias, can be measured objectively in animals (Bethell et al. 2012; Salmeto et al. 2010; Burman et al. 2008a; Mendl et al. 2010a; Matheson et al. 2008; Brilot et al. 2010; Bateson et al. 2011; Bateson & Matheson 2007; Doyle et al. 2011; Destrez et al. 2012; Douglas et al. 2012). A negative affective state is associated with more negative outcomes expected, and positive affective states with more positive outcomes expected (e.g. Bateson et al. 2011; Matheson et al. 2008).

Cognitive biases are expressed in response to both short-term changes in an individual's level of anxiety (state anxiety) and long-term differences in an individual's tendency to experience anxiety (trait anxiety) (Bar-Haim et al. 2007). Although both forms of anxiety are fundamentally different, their effects on learning processes have been shown to be the same (e.g. Eysenck et al. 1991). There is evidence suggesting that judgment bias in animals correlates with affective state. For example, pessimism has been found to be higher in dogs that also score highly in measures of separation-related distress (Mendl et al. 2010a), and starlings prone to stereotypic behaviour are more pessimistic than their non-stereotyping conspecifics (Brilot et al. 2010). The findings of Mendl et al. (2010a) show how affective state may be correlated with behavioural output, which not only has implications for how we assess the welfare impacts of anxiety-related behaviour in dogs, but also how a dog's affective state may relate to the behaviour it displays in both in training scenarios and in everyday life. The results of these studies highlight the importance of establishing a predictive model of animal behaviour that includes the influences of arousal and affective

state and their potential interactions with each other. At the time of writing, a few models provide starting points. Mendl et al. (2010c) proposed a model that integrated discrete emotions and dimensional states of 'core affect', to encompass both emotional valence and arousal. Combining arousal and valence to give core affect was proposed as a kind of currency that enables animals to prioritise actions based on discrete emotions in response to current events. Furthermore, the frequency of an animal experiencing various discrete emotions may influence its background mood, thus giving rise to emotional states unattached to particular events, which in turn influence the discrete emotions experienced.

An arousal construct has been proposed in which there are multiple arousal types, each for a specific type of response (e.g. feeding, locomotion, flight response etc.), under the influence of a general arousal system (see Jing et al. 2009 for review). Combining this arousal construct with the contribution of the affective state on cognitive processes in animals presents an opportunity to form a comprehensive picture of the effect of these variables on training outcomes. An affective neuroscience construct developed by Panksepp (1998) uses the concept of modes based on neural substrates to classify specific emotional states related to common behaviour in mammals. This may be viewed as a dimension additional to the multiple arousal constructs based also on specific responses. This is potentially a helpful start in integrating emotional states and arousal with behavioural output. However, in a practical sense, it is difficult to apply either construct to animal training scenarios. We may align the emotional mode of SEEKING with the arousal associated with foraging, for example, and consider it a harmonious state for training to occur, where trainers may get maximal commitment and focus from their animal trainees. Beyond such broad adoptions, there are difficulties associated with specifics, such as how to identify when the animals are in such a harmonious state and when they have slipped out of it, to where, and why. It is likely there is overlap between neural substrates and associated goal-oriented behaviour. For example, there is likely to be an overlap between RAGE and FEAR systems in defensive behaviour and RAGE and SEEKING systems in inter-male aggression (Panksepp 1998, pp.199-203). These

overlapping modes, while accepted as the nature of emotional states, may serve to confuse practitioners in application.

In the current article, we attempt to build on these foundations by offering specific examples that are regularly encountered by animal trainers. Including a multiple arousal type or multiple emotional substrate construct is beyond the scope of this paper. Rather, we hope to offer an intermediary framework for integrating constructs of arousal and emotion with operant conditioning in a context familiar to animal trainers in order to encourage adoption of more inclusive paradigms than operant and classical conditioning alone.

The interpretation of operant conditioning terms can be ambiguous.

Traditionally, reinforcers and punishers in operant conditioning have been considered strictly as stimuli, thus avoiding the difficulties with defining motivation and affective states (Baron & Galizio 2005). However, it has been shown, for example, that negative reinforcement (defined as increasing the frequency of a behaviour by withdrawing a stimulus) is associated with the onset of safety, which could be considered positive reinforcement (Baron & Galizio 2005). It is highly likely that there are emotional components to operant conditioning, and that affective states themselves can act as reinforcers or punishers. This has been considered in research into human drug addiction, where taking drugs assuages negative affect created by psychological conditions (e.g. Baker et al. 2004).

In the current article, we consider the influences of arousal and affective state on the processing of reinforcement and punishment. Here we take the simplest view of classifying reinforcement and punishment as positive (presented) or negative (withdrawn). Thus trainers often speak of the four quadrants of operant conditioning: positive reinforcement, negative reinforcement, positive punishment, negative punishment (McGreevy & Boakes 2007). The current article does not consider the effects of varying sensitivity to reinforcement and punishment between individuals. Evidence suggests baseline sensitivity to rewards may affect personality and individual tendencies towards broad behaviours such as reward-seeking, novelty-seeking and impulsivity (e.g. Hickey

et al. 2010; Depue & Collins 1999; Bogdan & Pizzagalli 2008). This may further affect individual animals' responses to different applications of operant conditioning, reflecting differences in how signals are assessed and the likelihood of approach-versus-avoidance behaviours. This is considered beyond the scope of the framework presented here.

This paper presents a conceptual model of how, depending on the training methods used, affective state and general arousal may influence training outcomes, as judged by the probability of the animal displaying a desired behaviour on cue. The model follows on from earlier work that provided conceptual, three-dimensional graphics using four quadrants to chart a horse's responsiveness to various cues from two reins and the rider's legs and seat (McGreevy et al. 2009b), and builds on broader, integrative constructs including arousal and affective state (Panksepp 1998; Mendl et al. 2010c). For the purposes of presenting a simplified concept, "desired behaviours" in this case are a series of target behaviours that represent a variety of responses commonly required of dogs or horses, the two species that are arguably the most commonly trained. "Undesired behaviour" is any behaviour that significantly detracts from or is incompatible with the target behaviour. The arousal-producing stimulus is assumed to be general in nature, for example, a large number of nearby competing stimuli (such as other animals and people undertaking energy-intensive activities).

Experimental Section

A series of response landscapes similar to the response surfaces used by Nijhout (2003) and discussed by Overall (2005) was created using the program Mathematica 8 (Wolfram Research, Champaign, IL) to represent how affective state and arousal levels may affect the efficacy of each operant-conditioning quadrant in training animals to perform particular behaviours. In this case, efficacy is considered the probability of the animal performing the desired behaviour, assuming the trainer is adept at applying the method in question in the sort of uncontrolled (non-laboratory) environments in which animal training

often takes place. It was assumed that competing stimuli, such as other animals and handlers and smells and sounds of ethological importance to the trainee animals, would be present and may play a role in increasing arousal or inducing changes in affective state. Dogs and horses were used as models to capture commonly encountered species-specific responses as well as commonly trained behaviours.

The graphs were based first on two matrices of putative data assembled by the authors: one deals with the probability of the dog performing the desired behaviour given different levels of arousal for each of the four quadrants (positive reinforcement, negative reinforcement, positive punishment, negative punishment), and the other deals with the probability of the desired behaviour given different levels of affect for each operant-conditioning quadrant. The data for both arousal and affective state were represented on a hypothetical 10-point scale, with 0 being the lowest arousal level and most negative affective state and 10 being the highest arousal level and most positive affective state.

Combining these two-dimensional matrices into three-dimensional matrices was achieved by first supplying a skeleton dataset of the probability of the desired behaviour for each quadrant (given hypothetical arousal levels of 0-10) and the probability of the desired behaviour being performed for each quadrant (given each point on the hypothetical affective state scale of 0-10), as discussed previously. Thus, each quadrant had an associated dataset of probability, given affective state, and probability, given arousal level. These values were based on discussions with trainers and observations of trialling dogs and experiences with horse riding, as well as drawing from the equitation science and dog training literature. The dataset was then filled out by generating numbers to fit the distributions defined in the two-dimensional matrices using a mathematical function with a semi-Bayesian statistic. It was assumed that affective state and arousal are independent, or at least have very low co-variance. This has not been shown empirically, but can be later tested with the collection of relevant data. Using this assumption, it follows that the probability of a behaviour occurring due to arousal A and affective state B equals the probability of a behaviour occurring due to arousal state A multiplied by the probability of a behaviour

occurring due to arousal state B. This follows the form of the Law of Multiplication in probability, which states that for independent events, the probability of Event A is not affected by the occurrence of Event B, so $P(A \text{ and } B) = P(A) \times P(B)$. This was used for all target behaviours.

Target Behaviours

The target behaviours chosen to map response landscapes were selected to represent a diversity of the types of behaviours animals are frequently trained to perform, and to capture behaviours that lend themselves more to different training methods. Given the earlier discussion of task complexity in the Yerkes-Dodson law, target behaviours were chosen to represent different complexities. For example, tracking, while being ostensibly a simple matter of following a scent trail, is considered to require a high level of attention to a narrow set of stimuli in comparison to the many, diverse, and at times distracting stimuli concurrently present in a tracking environment. Such distractions include other social objects, potential threats and opportunities for reinforcement unrelated to the target behaviour. In contrast, targeting is a fast and simple behaviour that is unlikely to require exclusive attention. Reinforcers and punishers considered as possible tools in the training of each behaviour were restricted to those tools most readily available. As such, stimuli such as electronic collars were not considered, because of their cost or restricted availability. Consideration was given to the availability of reinforcers and punishers to trainers depending on the target behaviour and readily available training tools. A description of the target behaviours and the reinforcers and punishments considered available for each operant training category are shown in Table 7.1.

| Species (Figure number) | Behaviour | Description | PR | NR | PP | NP |
|--------------------------------|------------------|---|---|---|---|---|
| Dog (1, 2) | Heel on leash | Dog to walk on loose leash in heel position | Food, play, or access to toy, praise and affection, release to engage in natural behaviours | Social pressure, physical pressure from leash | Loud noise, physical correction – leash or otherwise, shout | Withdrawal of access to reinforcers mentioned in PR |

| | | | | | | |
|------------|-----------------------------|---|--|---|---|---|
| Dog (3) | Heel off leash | Dog to walk in heel position unaided | Food, play or access to toy, praise and affection, release to engage in natural behaviours | Social pressure | Loud noise, shout, physical correction | Withdrawal of access to reinforcers mentioned in PR |
| Dog (4) | Tracking | Dog to follow scent trail to source | Food, play or access to toy, praise and affection, release to engage in preferred behaviours | Social pressure, separation from handler | Loud noise, shout, physical correction | Withdrawal of access to reinforcers mentioned in PR |
| Dog (5) | Stay | Dog to remain in stationary position | Food, play or access to toy, release from stay, praise and affection | Social pressure, physical pressure from leash | Loud noise, physical correction – leash or otherwise, shout | Withdrawal of access to reinforcers mentioned in PR |
| Horse (6a) | Target training (in-hand) | Horse to touch target with its nose | Food, scratching of the withers and neck | Pressure from the headcollar or bridle | Physical correction | Withdrawal of access to reinforcers mentioned in PR |
| Horse (6b) | Walk forward (under-saddle) | Horse to walk forward in response to pressure from the rider's legs | Food, scratching of the withers and neck | Pressure from rider's legs | Physical correction | Withdrawal of access to reinforcers mentioned in PR |

Table 7.1. Summary of the conditions considered in the formation of the response landscapes. Each target behaviour is named and described and the forms of positive reinforcement (PR), negative reinforcement (NR), positive punishment (PP) and negative punishment (NP) considered common and easily accessible are listed.

Results

The response landscape graphs generated from the original two-dimensional matrices were considered by the authors to represent a possible model illustrating the effects of arousal and affective state on the efficacy of different operant-training approaches in dogs and horses. The graphs show arousal levels on the x-axis, affective state on the z-axis, and the probability of the animal performing the desired behaviour on the y-axis. The resulting landscape shows how the probability of the animal performing the desired behaviour follows knolls, peaks and valleys, depending on the arousal and affective states of the

animal and the operant-conditioning technique being used to train a specific behaviour. Response landscape graphs are shown in the text, but may be accessed in interactive form at the following URL:

<http://hdl.handle.net/2123/8989>.

Figure 7.1. shows a breakdown of the conceptual response landscape for training a dog to heel on leash, displaying individual response landscapes for each operant training approach. In the figure, the y-axis tracks the possible probability of a dog heeling on leash depending on the dog's affective (z-axis) and arousal states (x-axis), both of which are shown on a simple, representative scale of 0-10, where 0 is low arousal and a very negative affective state and 10 is high arousal and a very positive affective state, respectively. **a)** shows the positive reinforcement response landscape, characterised by high probabilities of the dog heeling on leash, peaking at moderate arousal where arousal matches the required activity level, and positive affective state where the dog may be most attentive to opportunities to access reinforcers. **b)** shows the negative reinforcement landscape, which steadily decreases in efficacy as arousal and affective state values increase. Increased arousal may result in a higher likelihood of behaviours more active than heeling on leash and more positive affective state may be associated with greater distractibility as the dog attends to stimuli in the environment that may signal access to environmental reinforcers. These conditions may combine to reduce the dog's attention to negative reinforcement. **c)** shows the response landscape of negative punishment, which is most effective at high arousal and very positive affective state. In this condition the dog is likely to be attentive to opportunities to access reinforcement, yet may be prone to extraneous behaviour related to an arousal state higher than is appropriate for on-leash heeling. Negative punishment may aid in reducing undesired behaviour while maintaining desired behaviour. Efficacy may decrease with decreased values for arousal and affective state as dogs become more sensitive to reinforcement loss as their affective state declines, and less likely to persist in activities as arousal decreases. **d)** shows the response landscape for positive punishment. Efficacy is very low where affective state is negative and arousal is low as the dog is less likely to display any behaviours and

more likely to be sensitive to punishment. Efficacy increases only at high arousal and very positive affective state where the dog may be more likely to display excessive undesired behaviour that may benefit from strategic suppression. Response landscape graphs may be accessed in interactive form at the following URL: <http://hdl.handle.net/2123/8989>.

a) Positive reinforcement

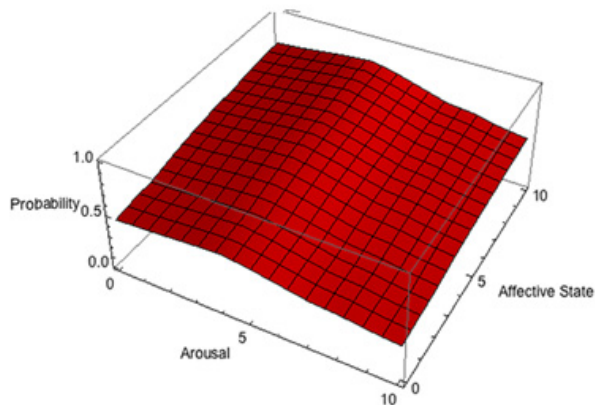

b) Negative reinforcement

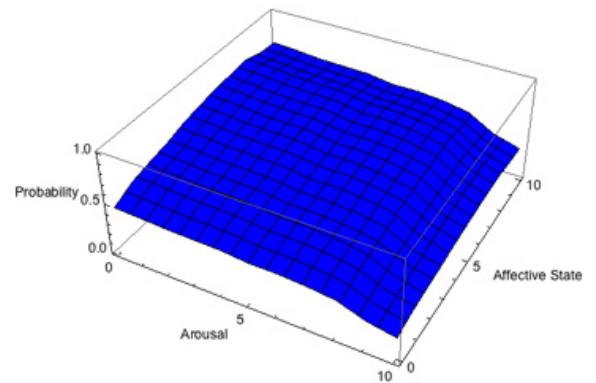

c) Negative punishment

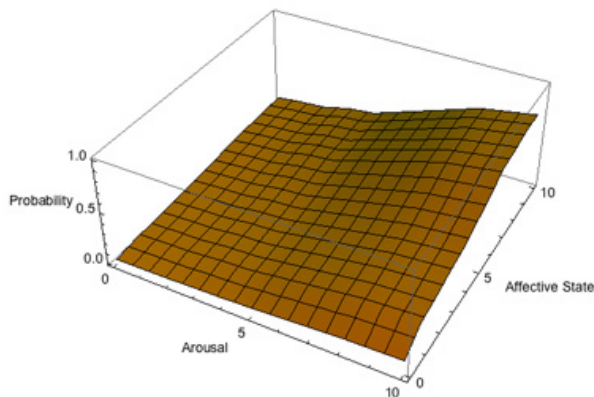

d) Positive punishment

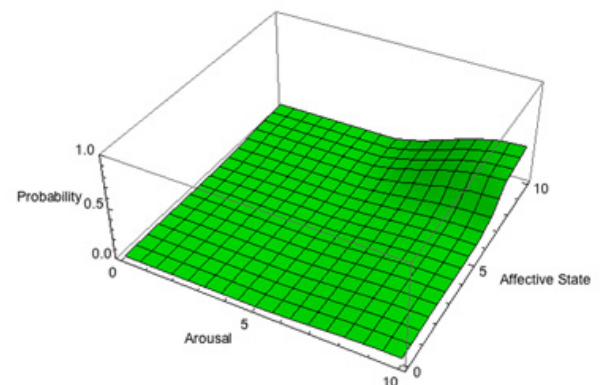

Figure 7.1. A breakdown of the conceptual response landscape for training a dog to heel on leash, showing each operant training quadrant on a separate graph.

Figure 7.2 shows the conceptual response landscape for training heeling on leash in dogs with all operant conditioning approaches combined into the one landscape. This illustrates how the shapes of each operant conditioning response landscape may interact with one another, showing where approaches may be most effective compared to other approaches. In the figure, two views of the same response landscape are shown: aerial view on left and side view on right. Red = positive reinforcement, blue = negative reinforcement, orange = negative punishment, green = positive punishment. The y-axis tracks the probability of a

dog heeling on leash depending on the dog's affective (z-axis) and arousal states (x-axis), both of which are shown on a simple, representative scale of 0-10, where 0 is low arousal and a very negative affective state and 10 is high arousal and a very positive affective state, respectively. This behaviour is performed in the presence of a leash, which may provide an effective means of applying negative reinforcement. Both positive and negative reinforcement are expected to gradually decrease in efficacy as arousal increases and affective state becomes positive, resulting in dogs displaying more energetically costly behaviour that may be at odds with steady, controlled movement, but positive reinforcement is predicted to peak at moderate arousal rather than low arousal. This contrasts with the response landscape for negative reinforcement and accounts for the apparent division in the negative reinforcement landscape by a knoll that erupts through the positive reinforcement landscape. Response landscape graphs may be accessed in interactive form at the following URL: <http://hdl.handle.net/2123/8989>.

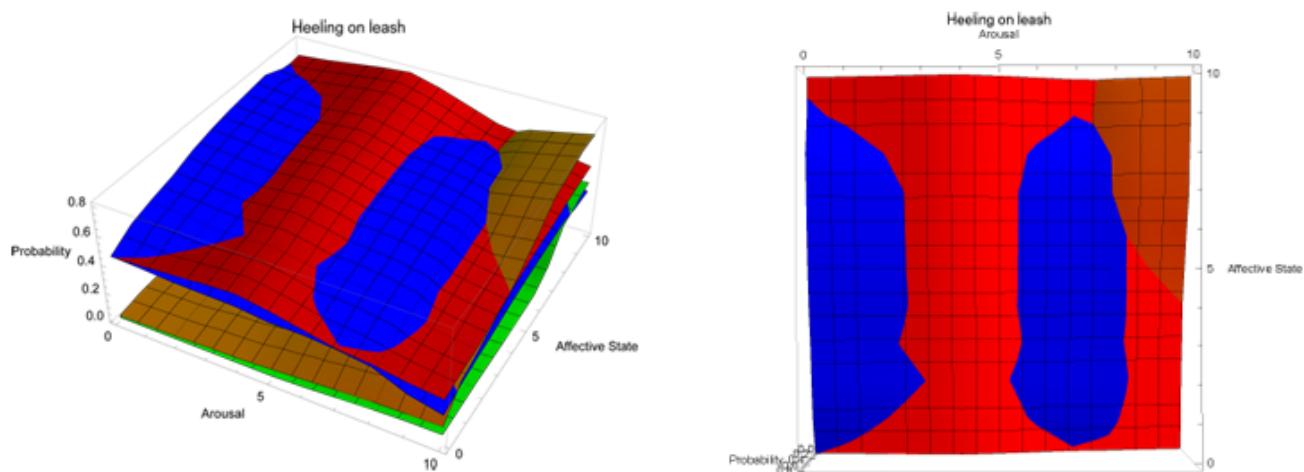

Figure 7.2. Combined conceptual response landscape for training heeling on leash in dogs using different operant training methods.

Figure 7.3 shows the conceptual response landscape for training a dog to heel off leash. In the figure, two views of the same response landscape are shown: aerial view on left and side view on right. Red = positive reinforcement, blue = negative reinforcement, orange = negative punishment, green = positive punishment. The y-axis tracks the probability of a dog heeling off leash depending on the dog's affective (z-axis) and arousal states (x-axis), both of which are shown on a

simple, representative scale of 0-10, where 0 is low arousal and a very negative affective state and 10 is high arousal and a very positive affective state, respectively. This behaviour requires the dog to willingly approach and remain in close proximity to the handler, as the behaviour by definition must be performed without the aid of restraining tools. Positive reinforcement dominates the response landscape in efficacy as it is well suited to encouraging approach behaviour. Its efficacy peaks at moderate arousal and positive affective state. At high arousal and very positive affective state, negative punishment may prove effective as it offers a means to decrease extraneous behaviour that may result from increased activity directed towards seeking and acquiring reinforcers. Restricting access to environmental reinforcers may be more difficult to achieve with the dog off leash, but may remain effective where it is possible. Response landscape graphs may be accessed in interactive form at the following URL: <http://hdl.handle.net/2123/8989>.

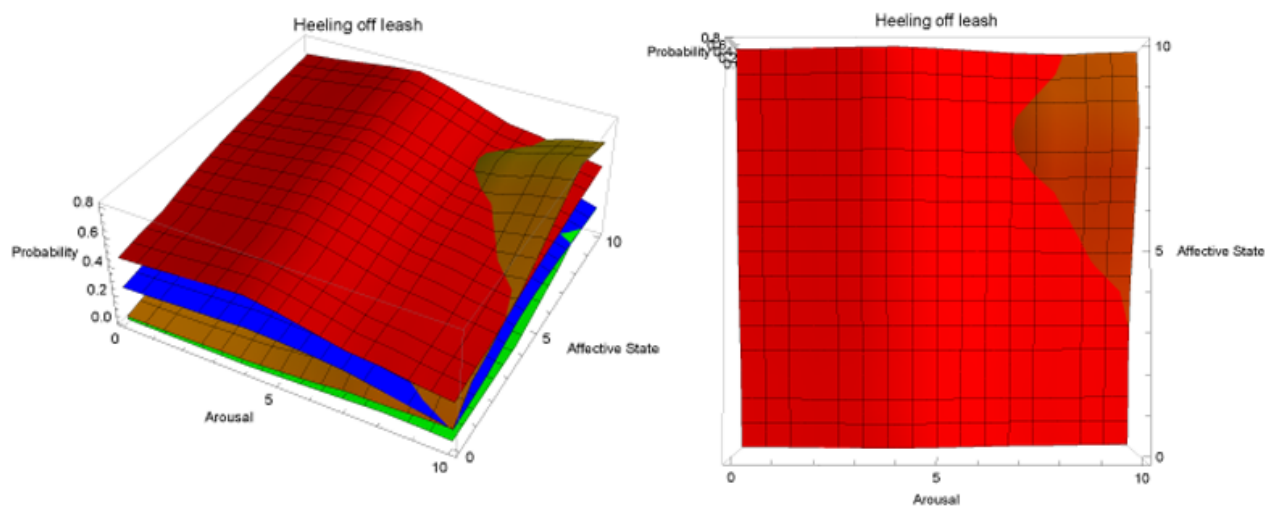

Figure 7.3. Conceptual response landscape for training heeling off leash in domestic dogs using different operant training methods.

Figure 7.4 shows the conceptual response landscape for training a dog to track a target scent through the environment. Like heeling off leash, this behaviour may be difficult to train with the use of physical training aids. In the figure, two views of the same response landscape are shown: aerial view on left and side view on right. Red = positive reinforcement, blue = negative reinforcement, orange = negative punishment, green = positive punishment. The y-axis plots the

probability of a dog successfully tracking depending on the dog's affective (z-axis) and arousal states (x-axis), both of which are shown on a simple, representative scale of 0-10, where 0 is low arousal and a very negative affective state and 10 is high arousal and a very positive affective state, respectively. This activity requires extended focus from the dog, which may be most efficiently supported across most states by positive reinforcement, as this is likely to encourage the dog to persist in the behaviour even when reinforcement is intermittent. It is possible that with low arousal and affective state values, negative reinforcement may be effective in creating the necessary motivation for the dog to perform this behaviour. At high arousal and affective state values, negative punishment in the form of taking the dog away from potential reinforcement may be effective in suppressing undesired behaviour related to inappropriately high arousal and positive affective state combining to distract the dog from the task. Response landscape graphs may be accessed in interactive form at the following URL: <http://hdl.handle.net/2123/8989>.

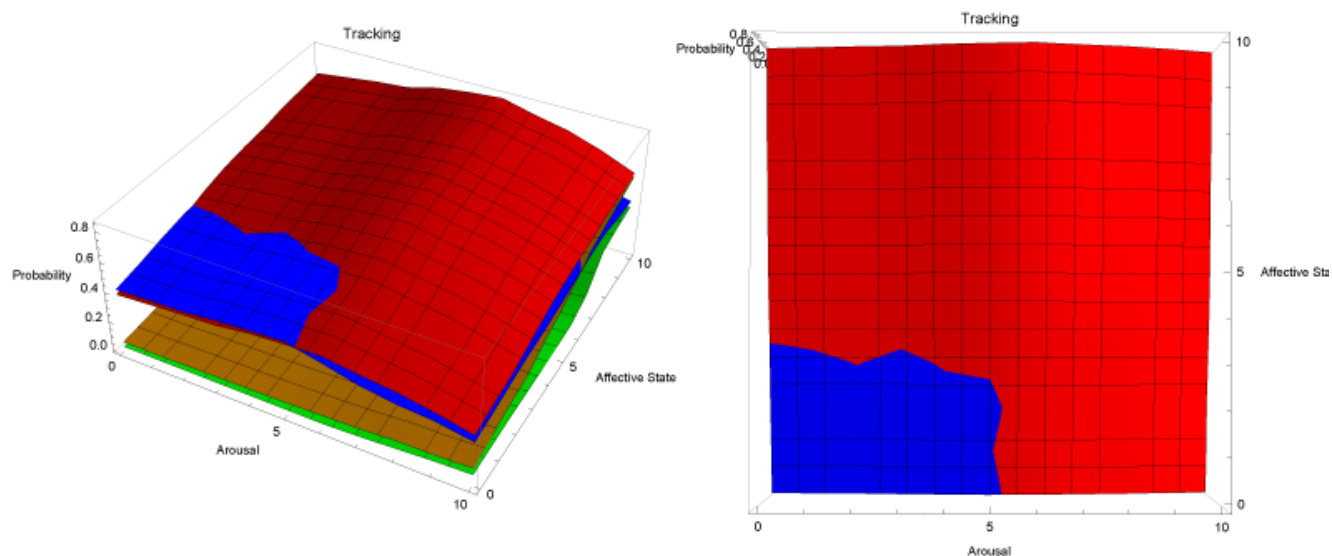

Figure 7.4. Conceptual response landscape for training a dog to track using different operant training methods.

Figure 7.5 shows the conceptual response landscape for training a dog to stay. In the figure, two views of the same response landscape are shown: aerial view on left and side view on right. Red = positive reinforcement, blue = negative reinforcement, orange = negative punishment, green = positive punishment. The

y-axis tracks the probability of a dog staying in place depending on the dog's affective (z-axis) and arousal states (x-axis), both of which are shown on a simple, representative scale of 0-10, where 0 is low arousal and a very negative affective state and 10 is high arousal and a very positive affective state, respectively. Stay is a stationary behaviour, so theoretically it may be possible to train this behaviour by suppressing all behaviour with the use of positive punishment, particularly if the dog is in a negative affective state and low arousal and is therefore not compelled to move very much in the first place. Willing cooperation may be useful at higher arousal and more positive affect, but may be difficult to obtain at the extreme of this condition using positive reinforcement where active seeking of reinforcement may become more likely. Negative punishment may be very effective in these conditions by encouraging impulse control. Response landscape graphs may be accessed in interactive form at the following URL: <http://hdl.handle.net/2123/8989>.

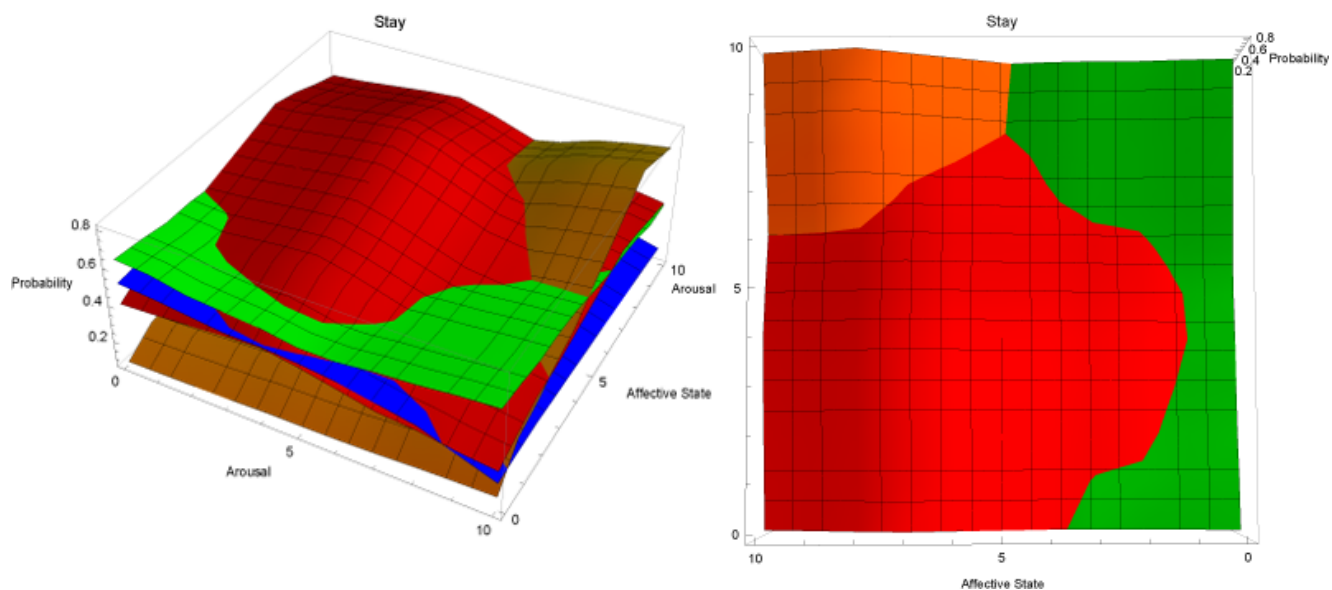

Figure 7.5. Conceptual response landscape for training dogs to stay (remain stationary) using different operant training methods.

Figure 7.6 offers the contrast of two horse examples, training a horse to touch a target with its nose and training a horse to move forward with a rider in the saddle. In the figure, red = positive reinforcement, blue = negative reinforcement, orange = negative punishment, green = positive punishment. The y-axis tracks the probability of the horse responding appropriately depending on its affective

(z-axis) and arousal states (x-axis), both shown on a simple, representative scale of 0-10, where 0 is low arousal and a very negative affective state and 10 is high arousal and a very positive affective state, respectively. Graph **a)** shows the training of a horse to touch a target on cue with its nose. Graph **b)** shows the training of a horse to walk forward on cue from a rider in the saddle. Horses are generally more prone to reacting with flight than dogs, as prey animals are dependent on flight for safety. This is shown in the low efficacy of punishment-related training that may be likely to trigger evasive action. The targeting response landscape is dominated by positive reinforcement, as it is an approach behaviour and thus most suited to seeking reinforcement. In contrast, the response landscape in **b)** is dominated by negative reinforcement, as it is difficult to deliver any strong positive reinforcers from the saddle. Response landscape graphs may be accessed in interactive form at the following URL: <http://hdl.handle.net/2123/8989>.

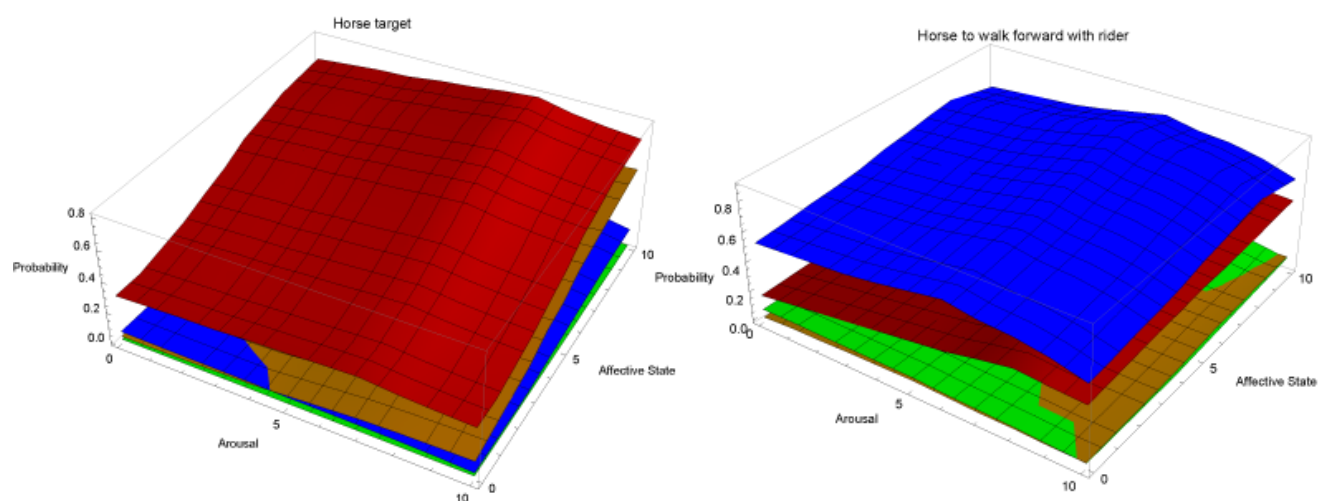

Figure 7.6. Conceptual response landscapes for training two common behaviours in the domestic horse using different operant training methods.

Discussion

The response landscapes presented here are conceptual only, and are presented to provide a launching platform for further discussion and the collection of data

to test the predictive powers of this model. The response landscape can be used to describe graphically how arousal and affective state may influence the efficacy of different operant conditioning training methods under typical environmental conditions. One important caveat is that all operant conditioning approaches are expected to be effective, and the effectiveness of one approach over others is likely to be linked to the previous conditioning of the animal, the skill of the handler in applying that approach, and how the handler routinely interacts with the animal (e.g. Haverbeke et al. 2008). The response landscapes may also be adapted to describe how the above factors and others involved in training animals affect the efficacy of different methods and their graphical nature may offer an accessible way to discuss the finer points of training with professional trainers who may lack a strong scientific background.

The response landscapes shown here highlight how the ability to deliver reinforcement or punishment can influence the efficacy of training methods. It could be argued that this deviates from a strictly theoretical approach. However, the emphasis here is on the interplay of affective state, arousal and learning in contexts regularly encountered by animal trainers. Necessarily, this interplay includes the ability of the trainer to apply reinforcement and punishment and takes into account readily available training aids, as well as the variables introduced by a dynamic environment in which training often occurs. The response landscapes for heeling on leash (Figure 7.2) and heeling off leash (Figure 7.3) are similar, which is an artefact of the behaviours being very similar and trained in the same environment, but the omission of a leash changes the efficacy of negative reinforcement. This is highlighted again in Figure 7.6b where negative reinforcement dominates the response landscape for training a ridden horse to move forward. The reinforcements the rider has control of from this position are extremely limited (see Table 7.1). In contrast, the response landscape in Figure 6a for training a horse to target is dominated by positive reinforcement. The reinforcements available to the trainer in training this behaviour are much broader.

All response landscapes highlight that the efficacy of different operant training approaches may change with arousal levels and affective state, and these changes may differ, depending on the type of behaviour being trained. For example, a 'knoll' can be identified in the response landscapes for positive and negative reinforcement while training responses that may run counter to those prompted by environmental stimuli. Examples shown here are heeling and remaining stationary (stays), where self-control may be required to perform steady locomotory responses or stationary behaviours in the presence of environmental stimuli that may trigger contrary movement and a higher associated level of arousal, such as fast-moving objects or other social objects. Self-control is thought to be a finite resource subject to depletion (Miller et al. 2010; Miller et al. 2012), reflecting additional complexity or difficulty to a task. This knoll may be a manifestation of the Yerkes-Dodson inverted-U, but with the added dimension of affective state. The inconsistency in this pattern across all training methods and behaviours may be explained by a more sophisticated arousal construct than a general one. The Yerkes-Dodson law is not universally accepted in the literature (Robbins 1997; Hanoch 2004), and some researchers have argued that arousal is an adaptive process that has evolved to help animals solve problems that they regularly encounter, and therefore high arousal states produce the behaviour needed to cope with specific problems (Hanoch 2004). This has led to more modern arousal constructs that include both a general arousal construct associated with the central nervous system (Pfaff et al. 2008) and specific arousal types under the influence of the general arousal construct. To the authors' knowledge, no such comprehensive arousal construct exists for animals in training, but the development of such a construct may aid in understanding the intricacies of how arousal and affective state influence training outcomes.

The response landscapes may be interpreted in two key ways. One way is as a guide to the possible efficacy of different training approaches, depending on the arousal and affective states of the animal during a training session. The second is as a map to where the animal's arousal and affective state will best complement the use of a particular training method, for example, there are good reasons to

preferentially use positive reinforcement. It is expected from research on cognitive bias in animals, that most animals in a negative affective state are more likely to interpret ambiguous signals as predictors of a negative outcome (Bateson et al. 2011; Destrez et al. 2012; Mendl et al. 2010a; Burman et al. 2009). For example, many urban dogs encounter ambiguous signals on a day-to-day basis, such as the subtleties of body language in an unknown dog or human, unidentified sounds and smells, and visual stimuli such as a white paper bag on the ground that may or may not contain discarded food. It can be argued that training interactions with humans also contain an element of ambiguity for dogs, such as interpreting hand signals or verbal cues and reading body language (McGreevy et al. 2012). As such, it is predicted that, in general, all operant training approaches will be negatively affected by a negative affective state. This has implications for the long-term effects of selecting training methods.

It is noted that all quadrants in operant conditioning are effective in that, when exposed to salient stimuli, animals will learn regardless of the quadrant used and animals have evolved to respond to all quadrants. Quadrant-based training paradigms do not represent a best practice approach to humanely training new behaviours, maintaining learned behaviours, or suppressing unwanted behaviours. The response landscapes for at-liberty behaviours in particular highlight this by showing how efficacy may vary given the arousal level and affective state of the animal. It is not the intention of the authors to promote a particular quadrant over others, but rather to promote positive affective state and appropriate arousal levels for the desired behaviour to facilitate training by maximising the likelihood of the behaviour occurring but also to help the trainer in troubleshooting. A shift in training towards building behaviours and reliability from the ground up where arousal and affective state may be considered basic foundations and training approach in an operant conditioning framework may be considered a secondary system that may benefit both animals and their trainers. It may promote the ethical treatment of animals by encouraging trainers to put their animals' emotional needs first and also help trainers to obtain the desired behaviours and associated reliability in performance by bringing animals to a place in the core affect landscape, where the animals are at

their most responsive, first. We propose that trainers radiate out to other places in the core affect landscape later in training. This is not necessarily a different way of training, but the intent is to shift the focus away from first getting behaviours by whatever operant conditioning means necessary to first building the appropriate emotional and arousal foundations. Arguments that certain operant conditioning approaches are more effective than others may be true in some circumstances (e.g. Tortora 1983), yet may fail to take into account the merits of first manipulating arousal levels and affective state to create conditions in an animal that best complement training methods associated with ease of application and promotion of positive affective state and appropriate levels of arousal. Arguments that certain operant conditioning approaches are more effective than others may be true in some circumstances (e.g. Tortora 1983), yet may fail to take into account the merits of first manipulating arousal levels and affective state to create conditions in an animal that best complement training methods associated with ease of application that also promote positive affective state and appropriate levels of arousal. This may be achieved through various means, for example, arousal levels can be manipulated by desensitising or using classical counter-conditioning to allow the dog to feel comfortable in a stimulating, outdoor environment so that the dog is not compelled to attend to competing stimuli. This may also improve affective state by reducing the number and/or intensity of threatening stimuli in the environment where training takes place.

Long-term effects of the operant training approaches are not considered in the current conceptual response landscapes. However, we predict that to some extent at least there are feedback mechanisms involved in both the long and short term. Regular exposure to positive reinforcement is likely to aid in maintaining a positive affective state, and regular exposure to aversive stimuli is likely to aid in maintaining a negative affective state, generating long-term positive and negative moods (Panksepp 1998). As such, aversive methods aimed at suppressing behaviour may be effective in the short-term, but repeated use may push animals into a general negative mood. There is evidence that punishment used in dog training is associated with increased incidence of

aggression, particularly directed towards the handler (Rooney & Cowan 2011; Herron et al. 2009; Blackwell et al. 2008; Haverbeke et al. 2009), while compromising performance in obedience and protection work (Haverbeke et al. 2009), and reducing willingness to approach strangers and engage in playful activities outside of training (Rooney & Cowan 2011). Furthermore, punishment-based training is believed to have the potential to create general anxiety in dogs (Blackwell et al. 2008) and has been associated with distress where timing is inexact (Schalke et al. 2007; Schilder & van der Borg 2004). Inappropriate use of aversive stimuli is of particular concern in horse training (McLean & McGreevy 2010; Jones & McGreevy 2010). These indications suggest repeated and prevalent use of punishment in training may be associated with inducing a negative affective state in animals. It may also hamper the formation of the human-animal bond, which in turn is thought to play an integral role in trainee focus and, therefore, training outcomes (Haverbeke et al. 2008). In contrast, reward-based training has been shown to be associated with improved focus and ability to learn a new task (Rooney & Cowan 2011; Range et al. 2009). The broaden-and-build theory in human affective neuroscience holds that positive emotional states encourage behavioural flexibility and resilience (see Garland et al. 2010 for review). To the authors' knowledge, this has not been studied directly in non-human animals, but some similarities may be identified. Positive affect appears to have benefits for focus and performance in learning new tasks. Play, which is strongly associated with a positive emotional state, may have several positive effects at the level of the individual animal. This may be particularly apparent in a social arena where animals that play may be more adept at acquiring mates, coping with intraspecific competition, and making affiliations, but effects may also be seen in a decrease in problem-solving ability and a decrease in habituation and fear in animals that did not play (see Panksepp 1998, p.294 for review). Extant work in this domain focuses on rats, but is likely to be applicable to other mammals. Whether these effects are due to positive affect or the skills learnt in play is unclear, but perhaps the differentiation is irrelevant for inclusion in the broaden-and-build theory.

These feedback systems can explain some of the features in the response landscapes presented here. Where the animal is already in a negative affective state or it perceives competing stimuli as threatening, the animal is expected to pay more attention to threatening stimuli, as has been shown in human studies (Eysenck et al. 1991; Mathews & MacLeod 1985), and the resulting arousal would be geared towards readying to act in order to avoid or escape from potential danger. As arousal increases in the condition of negative affective state, affective state is likely to become more negative, and the probability of the animal offering a desired behaviour is likely to decrease across all operant-conditioning quadrants. That said, the effectiveness of negative reinforcement is postulated to increase as the need for the animal to escape threatening stimuli intensifies until arousal levels are high enough to provoke flight or fight responses.

Conclusions

Response landscapes may offer a framework both for discussing the effects of different factors on training efficiency and communicating those effects to laypeople. Recent studies suggest a need for a predictive model of behaviour that incorporates arousal, affective state, and operant conditioning. Response landscapes are used here as a graphical means to represent a preliminary, conceptual model incorporating these factors. Simple measures of affective state and arousal would provide the means to test the current predictions and enable the adoption of a more complete model of species-specific behaviour during training than that offered by operant conditioning alone. A comprehensive arousal construct for individual species, including multiple types of arousal as well as general arousal, may aid in understanding how animals will respond to various training methods in the presence of different competing environmental stimuli.

Acknowledgments

The authors would like to acknowledge the valued contribution of four anonymous reviewers. The authors would also like to acknowledge the support of Black Dog Wear Pty Ltd and Positive Puppies.

Conflict of Interest

The authors declare no conflict of interest.

Author Contributions

This chapter includes an original paper submitted to the peer-reviewed journal "Journal of Veterinary Behavior: Clinical Applications and Research". The candidate contributed to the ideas that form the basis of the paper, and the writing of the paper. The candidate was working at all times within the Faculty of Veterinary Science under the supervision of Dr Paul McGreevy (primary supervisor). Dr McGreevy, as first author, played a leading role in finalising the manuscript prior to publication. Dr McGreevy, Cathrynne Henshall, Dr McLean, and Dr Boakes contributed to the ideas and writing of the paper.

The inclusion of co-authors reflects the fact that the work came from an active collaboration between researchers and acknowledges input into team-based research.

Confirmation of Co-Authorship of Unpublished Work

I, *Melissa Starling*, contributed to the ideas and writing up of the manuscript entitled "***The importance of safety signals in animal handling and training***".

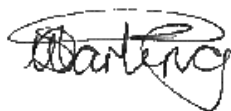

Melissa Starling _____ Date 8 July, 2013

I, as a Co-Author, endorse that this level of contribution by myself and the candidate indicated above is appropriate.



Dr Paul McGreevy _____ Date 25 July 2013



Cathrynne Henshall _____ Date 6 July 2013



Dr Andrew McLean _____ Date 8 July 2013

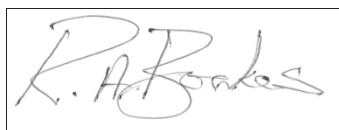

Dr. Robert Boakes _____ Date 8 July 2013

8 The importance of safety signals in animal handling and training

Paul McGreevy^a, Cathrynne Henshall^a, Melissa Starling^a, Andrew McLean^b, Robert Boakes^c

^a Faculty of Veterinary Science (B19), University of Sydney, NSW 2006, Australia

^b Australian Equine Behaviour Centre, Broadford, VIC 3658, Australia

^c School of Psychology, Faculty of Science, University of Sydney, NSW 2006, Australia

This paper has been submitted to the peer-reviewed journal *The Journal of Veterinary Behavior: Clinical Applications and Research*, 2013.

Abstract

This review considers the importance of safety for various species of domestic animals and explains how the need for safety may motivate them to offer a variety of unwelcome responses. We argue that the value of safety to animals is often overlooked by trainers and handlers. As a result, animal owners, handlers, trainers and veterinarians are regularly injured and training may fail. Reinforced responses that increase the animal's perceived sense of safety but simultaneously endanger the safety of handlers or trainers may lead to the inadvertent training of dangerous responses. This review offers suggestions about how safety can be used effectively and humanely as a resource in operant training. Training calmness in the presence of a specific stimulus that is associated with safety may deserve closer attention. The ethics of creating the need for safety in domestic animals as part of a training regime are discussed. It emerges that the highly prized attribute of so-called trust in animal-trainer dyads may, at least sometimes, be a manifestation of trainers as safety signals. Similarly, animals said to have confidence in and regard for their handlers may value the relative safety they afford.

Keywords: safety; safety signals; fear-based training; horse; dog; human safety

Introduction

Animals are always learning, whether that is during human-guided training in domestic contexts, or simply finding ways to cope with their environment and coexist with the individuals with whom they associate. Given that we have embarked on a path of bending the will of animals to our own, it behooves us to consider the stimuli that motivate them beyond the obvious primary reinforcers: food (most common in contemporary dog training) and removal of pressure (most common in contemporary horse training) (McGreevy & Boakes 2007). Good trainers suppress unwelcome responses and draw out desirable ones, eventually putting them under stimulus control so that they are offered only on cue. When fear motivates an unwelcome response, punishment aimed at suppressing such a response is less likely to be effective and far more likely to have a negative impact on emotional state, further confounding efforts to draw out desired responses. An understanding of fear responses is therefore central to making training decisions that maximize good outcomes for both humans and animals (McLean & McGreevy 2010).

A safety signal is defined in the psychology literature as a stimulus that predicts the non-occurrence of an otherwise expected aversive stimulus and as a result has become a conditioned inhibitor of fear responses even in novel situations (Gray 1987). The term is also used to label signals that inform an individual when it is safe (Seligman 1968). The physiological response to a safety signal is sometimes broken down into relief and relaxation, where the former is an almost immediate and short-lived autonomic event and the latter a later-onset, striatal muscle event (Denny 1983), but both are still considered components of avoidance learning. A second common usage of the term 'safety signal' implies a generalized absence of aversive stimuli and may be trained by association with relaxation and safety (e.g. Haug 2008). It is unknown whether these two uses of the term are analogous, particularly given that the former is linked with avoidance learning and the latter with a state of relaxation, making them seem unlikely bedfellows, despite the relaxation component of avoidance learning

(Weisman & Litner 1969). Instead of attempting to tease these concepts apart, in this paper we consider current uses of safety signals in avoidance training and potential uses of learned and ethological safety signals that develop naturally to aid in training and management.

To these ends, this article provides a review of fear responses in animals, their adaptive purpose, how they are expressed, and how animals seek subsequent safety. Fear responses in domestic animals are discussed with reference to animal welfare and human safety in various occupations. The function of natural safety signals is presented, and possible ways to use safety signals strategically to improve animal welfare, human safety, and to obtain desired behaviors from animals in training, husbandry and management. Although we focus on examples that come from horse and dog training, the principles apply very widely across species, including elephants, livestock and exotic animals, which may undergo training in contexts such as zoos, circuses or film work.

Fear responses

Ethological context

Fear, as a reaction to perceived danger, is characterized by behavioral and physiological changes that enhance the animal's ability to deal with that danger (Fraser 1992; Boissy 1995; Randall & Burggren 2001). Fearful responses are adaptive to external factors affecting the animal's homeostasis (Fraser 1975; Kilgour 1978), and can thus be considered a subset of stress. Fear responses are strongly selected for because they promote biological fitness. For example, alarm signals reported in ungulates in response to predator stimuli (Caro 2005) are said to function in various ways that include increasing group cohesion, alerting conspecifics, providing individual identification during flight and as a distraction or decoy used against a predator (Müller-Schwarze 1991). However, excessive or prolonged exposure to stressors that elicit fear responses may impair fitness by imposing physiological costs and behavioral changes that interfere with immune competence, ontology and reproductive success (Moberg & Mench 2000). In many animal-training contexts, animals may react fearfully to stimuli that pose

no actual threat to their homeostasis (Gaynor & Muir 2009). Such reactions may endanger handlers and the animals themselves as well as hindering the success of training (Hawson et al. 2010).

Laboratory research on fear and avoidance learning

Laboratory studies of fear responses have largely focused on aversive conditioning. These reveal a great deal about the way in which associations with fear and, ipso facto, the absence of safety, develop. An enormous range of species has been studied, from rodents and other mammals (Overmier & Seligman 1967; Zieliński & Plewako 1980; Powell & Peck 1969; Fenton et al. 1979), to pigeons (Dinsmoor & Sears 1973), fish (Carpenter & Summers 2009; Bintz 1971; Dunlop et al. 2006), to green crabs (Abramson et al. 1988), to headless cockroaches (Weiss & Penzlin 1985) and to humans (Lovibond et al. 2013). The aversive stimuli applied may depend on the species being studied. On the whole, the noxious stimulus most frequently employed in standard aversive conditioning procedures is electric shock. This can be precisely controlled and calibrated and even at low intensities resists habituation (McGreevy & Boakes 2007).

Two broad experimental designs have been developed: discriminated and non-discriminated (free operant) procedures. Discriminated procedures include temporally paired Pavlovian and operant conditioning. An arbitrary stimulus, labeled a warning or conditioned stimulus (CS), is temporally paired with the noxious or unconditioned stimulus (US) to which the subject is exposed. An association develops between the CS and US. In contrast, non-discriminated or free operant designs omit the specific arbitrary stimuli and deliver the shock on a fixed schedule, the frequency of which can be reduced by the performance of the operant response (Sidman 1953). Operant responses are usually simple, such as jumping (Smith & Levis 1991; Mowrer & Lamoreaux 1946; Cândido et al. 1991) or pressing a lever, button or panel (Seligman 1968).

The outcomes of aversive-conditioning studies share many similarities, despite large differences among studies in species, devices and experimental designs. Animals learn to perform a specific behavior to escape or terminate the US. Due

to its pairing with the US, the CS warns the subject, which eventually learns to respond to it and avoid experiencing the US altogether. The response that terminates a CS and prevents the US from occurring is known as an avoidance response, to distinguish it from an escape response that terminates a US. As the noxious stimulus is not experienced, the avoidance response has no obvious source of reinforcement (Mowrer & Lamoreaux 1946). This phenomenon puzzled researchers for much of the 20th century because the source of the reinforcement was unclear (Rescorla & Solomon 1967; Herrnstein 1969; Domjan 2010).

Mowrer (1939) made the important and highly influential claim that pairing the CS (or warning signal) with the US produced conditioned fear of the CS and, consequently, the avoidance response that resulted in the termination of the CS (prior to the onset of the US) and enabled the animal to escape from the state of fear excited by the CS (Dinsmoor 2001; Bouton 2007). The theory as to how both Pavlovian and operant conditioning functioned in the acquisition of the avoidance response became known as Two-Factor Theory (Mowrer 1939; Mowrer & Lamoreaux 1942). This argued that an avoidance response resulted from both the Pavlovian association between the CS and US, and the operant response, which achieved either termination of the US in escape trials or the CS in avoidance trials. It identified the reinforcement for the avoidance response as the animal achieved offset of the CS and the fear conditioned to it (Rescorla & Solomon 1967). Later research has shown that while behavioral and, in some cases, physiological states of fear were high during response acquisition, signs of fear attenuated once avoidance responses reached asymptote (Solomon et al. 1953; Mineka 1979). Starr and Mineka (1977) found that rats trained to a criterion of 27 correct avoidance responses showed reduced fear of the CS compared with those trained to only three or nine responses. As such, the acquisition of a successful avoidance response can be considered to have an inhibitory effect on fear responses.

As well as the finding that, after extensive training, the CS evoked little fear (Mineka 1979), the original version of Two-Factor Theory (Mowrer 1960) was

also challenged by results indicating acquisition of avoidance behavior with non-discriminated procedures that omitted any explicit CS/US pairing (Bouton 2007; Domjan 2010). However, after incorporating the concept of safety signals, the revised Two-Factor Theory provides a powerful theoretical framework for understanding the etiology of response acquisition in animal-training contexts as well as the performance of unwanted avoidance responses to seemingly innocuous cues. Horses are well known for developing conditioned fear towards random objects encountered in their environment, such as rubbish bins, feed bags and umbrellas (McLean 2003). If, on initial exposure to the item, the horse escapes and this is reinforced, it may hereafter demonstrate behavioral fear and perform avoidance responses when re-exposed to the stimulus at lower intensities. In common with experimental findings, successful avoidance responses are highly resistant to extinction, which suggests that the inhibition of fear resulting from the avoidance response is reinforcing (Solomon et al. 1953).

Safety signals in laboratory research

Safety signals in avoidance learning

In some experiments on avoidance learning, providing a stimulus that occurred whenever – and as soon as – an animal made a successful avoidance response was found to increase the speed at which the avoidance response was acquired (D'Amato et al. 1968; Seligman & Johnston 1973; Cândido et al. 1991; Brennan et al. 2003). The stimuli paired with the absence of the US included lights (Cândido et al. 1991; Brennan et al. 2003), tones (Cicala & Azorlosa 1985) darkness (Callen 2004) and locations within a device (McAllister & McAllister 1992). In addition to accelerating acquisition of an avoidance response, such safety signals were also found to acquire fear-inhibitory properties and to become positive reinforcing events (Bower et al. 1965; Morris 1974; Gray 1987; Dinsmoor 2001). Avoidance learning takes place more rapidly with some kinds of responses, and with some kinds of stimuli as CSs, than with others. Bolles (1970) found that possibly the fastest learning was achieved when the avoidance response is a species-specific defense response. In rats, auditory CSs were found to be more effective than visual stimuli such as lights (Zieliński et al. 1991). It seems very likely, therefore, that certain kinds of stimuli can more easily become

effective safety signals than others, although to date there is no direct experimental evidence supporting this possibility.

Safety signals in socialization

An important analysis of socialization proposed that arbitrary stimuli can become safety signals during this process, although this was not the term used by the authors (Hoffman & Ratner 1973). While referring to dog, primate and human studies, their evidence came mainly from experiments on filial imprinting in ducklings. As is widely known, precocious young birds such as ducklings come to follow an imprinted object. Less widely known is that the more general response to an imprinted object is to reduce fear and that such an object can serve to reinforce instrumental behavior, especially when the animal is frightened. Thus, in mammals, the feel and smell of the mother of a very young animal – or of some mother substitute such as the human owner – can innately function to reduce fear of novel events or places; then, by a process of association, other aspects of the mother – her appearance, sound and the way she moves – acquire the same properties. As imprinting studies have shown, once stimuli have become effective safety signals, they rarely lose this property.

Safety signals and welfare

In animal training and handling

Experimental arbitrary stimuli can become predictive of safety and it is therefore entirely likely that stimuli innate to the animal's environment may have a predictive value for safety. In social species, such as dogs and horses, it is likely that conspecifics may function as safety signals (Christensen et al. 2008). This has been integrated into police horse training (McGreevy & Boakes 2007). Calm conspecifics, which signal the absence of danger or threats, may be more valuable than fleeing conspecifics. This is suggested by the attractive effect on runaway racehorses of calm stewards' horses rather than the rest of the field that is still in flight. Perhaps it may be useful to establish the most calming silhouette or three-dimensional shape for equine observers. We propose that equine shapes and models with low postural tonus will be more attractive than

those with high postural tonus and that those that appear to be grazing are more attractive than those that are not. Ingestive behavior is incompatible with flight responses and, in horses, requires that the head is lowered, limiting the ability to survey for potential sources of danger, such as predators or aggressive conspecifics. The characteristic postural tonus and locomotory characteristics of grazing horses are substantially different from horses in flight and it may be that the shape of grazing conspecifics functions as a safety signal in horses. There is evidence that horses respond to two-dimensional equine silhouettes in ways that align with intra-specific greeting (Grzimek 1952). Therefore it may be prudent to train horses in the presence of representations of calm conspecifics.

In the ridden horse

Improved knowledge and understanding of horse behavior and the impact of humans in such relationships may improve horse welfare and human safety (Hawson et al. 2010). Flight responses are especially dangerous, with the potential to result in horse and/or rider deaths, so reducing fearfulness represents a critical element for safe and humane horse handling and training. Conspecifics behaving normally and traveling steadily are likely to provide inherent safety signals in a species that lives in a herd (Christensen et al. 2008). Perhaps through classical conditioning, familiar humans can take on the same role. A familiar human standing beside an aversive object can facilitate a horse to habituate to it (Christianson et al. 2012). The value of the safety afforded by humans will, of course, depend on the horse's experience with the human leading it and with humans in general. It may be that some horses discriminate between familiar and unfamiliar humans (Lampe & Andre 2012; Proops & McComb 2012). This can work to one's advantage if the horse has a history of not being fearful of humans and rapidly generalizes from one familiar owner to humans in general more quickly than others. Perhaps this assists us in defining the elusive notion of 'trust'. Horses that have learned that humans in the presence of floats (trailers/boxes) are associated with an aversive outcome (e.g., that they are more likely to experience aggressive human behavior) are less likely to benefit from an unfamiliar human as a safety signal. This suggests that horses being loaded using negative reinforcement (via the removal of gentle but

persistent tapping on the side) or positive reinforcement will load with different speeds, dependent first on their prior experience with humans in such a context. This merits further investigation.

We propose that fearful horses do not greatly value food (such as otherwise highly prized tidbits) or comfort (the removal of pressure) but, instead, value safety to the extent that they will run towards safety signals. It has been theorized that responses which achieve escape from, or avoidance of, an aversive stimulus may become conditioned safety signals (Dinsmoor & Sears 1973). This could explain why flight responses from apparently innocuous stimuli that are reinforced by achieving distance from the fear-inducing stimuli may be learned in a single trial and are resistant to extinction (Bolles 1970; McGreevy & McLean 2010). Similarly, a bolting horse, almost by definition, cannot be slowed by pulling the reins. Various topographic and olfactory signs that the horse is heading for home are likely to be valued. Anecdotally, horses are renowned for successfully returning home after losing their riders, even when at a distance from the home location. Similarly, at competitions, fleeing horses will evade capture by people, as well as ignoring the apparent safety of unfamiliar horses in order to traverse the shortest distance back to their float or truck.

In horse management

Recent studies have considered the importance of visual stimuli in early human-foal interactions (Henry et al. 2005). It is possible that visual stimuli function to reduce arousal and this may explain why mirrors in stables can reduce stereotypic behaviors, such as weaving and nodding (McAfee et al. 2002; Mills & Riezebos 2005). Further to this, significantly less weaving behaviors were seen when a two-dimensional poster of a horse was supplied, compared to control images (Mills & Riezebos 2005). The reasons for this effect are still under investigation but may relate to the reflected image's ability to reduce social distress. It therefore follows that we may be able to apply a related approach to modify other distress-related behaviors, such as fearful responses to novel stimuli through associative learning (Lethbridge 2009).

A foal's behavior and relationship with humans is affected by what it observes. For example, the foals of dams brushed and fed by hand for the first five days of the foals' lives have been shown to be more accepting of human interaction and spend more time initiating physical contact with humans compared to control foals, and this difference has been shown to persist a year later (Henry et al. 2005). It is reasonable to hypothesize that a foal will be able to transfer information about its dam's response to and lack of flight from a two-dimensional image to real-world situations given that the ability of horses to discriminate between two-dimensional images of people and then transfer this knowledge to a three-dimensional representation has recently been confirmed (Stone 2009). This phenomenon could be exploited to reduce fear responses and thus, possibly, increase horse and human safety, as well as horse welfare in future human–horse interactions.

In veterinary contexts

Working with animals presents various dangers, so animal handling is a critical skill for veterinary students and veterinarians. In an Australian study of 2800 veterinarians, 51% reported a significant work-related injury during their career and 26% reported having an injury within the past 12 months. In addition, large-animal practitioners were most likely to have chronic or significant injuries (Fritschi 2006). In a similar US study, 65% of veterinarians had sustained a major animal-related injury and 17% had been hospitalized within the previous year (Landercasper et al. 1988).

Veterinary interventions may involve exposing the horse to uncomfortable, painful or novel stimuli that may elicit defensive behaviors, such as rearing or kicking, which can result in injury to veterinarians and handlers. Deficits in prior handling or past training, lack of competence in handlers, the extent to which the horse is already primed with adrenalin secondary to trauma or pain and inadequate facilities may increase the likelihood of dangerous flight behavior. It has been anecdotally reported that some horses react fearfully to the sight of an approaching vet, a possible example of conditioned fear. Consequently, the means by which veterinarians could instead acquire fear-inhibiting properties

would be of significant benefit to their personal safety as well as the safety of handlers.

Dogs in the home and in public

As predatory carnivores, both aggressive and fearful dogs have the capacity to do harm to people and other animals. Although unrestrained dogs biting the public at large often receive attention from the media, dog bites are generally from dogs that are owned by or familiar to their victims (Ozanne-Smith et al. 2001). Canine aggression is the most common problem behavior seen by veterinary behaviorists and general veterinary practitioners (Bamberger & Houpt 2006; Overall 2004). Clearly, aggressive behavior can often be an expression of fear, but it can also occur in the complete absence of any fear, for example, when an obviously harmless intruder enters a dog's territory. Although sometimes described by victims and owners as having occurred without warning, aggressive responses usually tell us that the dog has simply been pushed to defend its resources, its pups or itself. However, this does not necessarily indicate a fear state. In effect, some bites are the result of impulsive aggression and resource guarding, but a significant proportion are likely to be related to fear (McGreevy & Calnon 2010). This helps to explain why shelters generally assess fearful dogs as being unsuitable for rehoming (Mornement et al. 2010), so it is pertinent to ask why so little research has gone into the study of safety signals in dogs?

Using the Two-Factor Theory described earlier, we can imagine how dogs may learn to behave aggressively as a way to avoid potentially aversive interactions with other dogs or humans. If their behavior is reinforced by the perceived avoidance of an aversive interaction, they may treat the appearance of other dogs or humans as a discriminative stimulus informing them to behave aggressively to avoid an aversive interaction. This behavior may be subject to very few prediction errors (Li & McNally 2013). All interactions are successfully avoided and thus the behavior becomes very resistant to extinction, as has been observed with avoidance-motivated aggression (Tortora 1983). Attempts to create a prediction error by forcing an interaction that does not result in an

aversive outcome are likely to work in the opposite way and, instead, confirm that the appearance of the previously avoided dog or human is indeed predictive of an aversive interaction resulting from the uncomfortable proximity of that dog or human.

Tortora's (1983) safety training involved the use of a signal that indicated no electronic-collar stimulation when the dog performed the desired behavior, and which was then generalized to train dogs to behave appropriately in situations where they previously showed avoidance-motivated aggression. It was hypothesized that, as many cases of aggressive behavior in dogs were motivated by avoidance, the most effective way to counter-condition a dog exhibiting such behaviors so they would no longer be compelled to behave aggressively was through avoidance learning. The alternative responses sought were non-aggressive, pro-social behaviors that would also aid owners in controlling their dog's movements (obedience behaviors and a 'play' signal). It was further hypothesized that the probability of aggressive behavior would be an inverse function of the number and proficiency of pro-social behaviors the dog learned to exhibit instead. The safety training was therefore aimed at conditioning the dog to perform many pro-social avoidance behaviors so that they were more likely to occur than aggressive behaviors, and a conditioned safety signal was used to reinforce pro-social habits and simultaneously reduce fear reactions. Dogs were trained to offer 15 obedience behaviors to progressively higher criteria. Play bouts signaled with the 'play' signal were used as a positive reinforcer throughout the training and, as training progressed, escape from electric collar stimulation was used in addition as a negative reinforcer. In the later stages the safety signal was added as a negative reinforcer, and in the final stages shock was used only as punishment for non-compliance or aggressive responses while reinforcers were phased out. Safety training combined with the use of reinforcement for an alternative behavior resulted in dramatic and lasting (more than the following two years) reduction in aggressive behavior so that it was no longer considered a problem. Some modern training methods are based on similar acquisitions of safety, taking advantage of aversive CS in the environment and in artificial setups rather than using an electronic collar. For

example, Constructional Aggression Treatment and Behavior Adjustment Therapy are both based on training dogs to offer more socially appropriate behaviors by reinforcing such behaviors with increased distance from the stimulus (Snider 2007; Stewart 2011). Similarly, exercises aimed at giving dogs a coping strategy for the detection of potential aversive stimuli accompanied with a 'look, don't touch' rule may act to give dogs a sense of successfully avoiding an aversive event (e.g. McDevitt 2007). Dogs are reinforced, usually with food, for performing new coping behaviors. These behaviors may become associated with reduced fear similar to that shown to occur in the laboratory. These cases indicate that the use of safety signals can be effective in the treatment of canine behavior problems. Establishing safety signals for dogs could well become a routine part of training so that they are available to be used when the dog is agitated or engaging in distance-increasing behavior.

Trust and confidence

Animal-training manuals often focus on the importance of developing a bond with animals based on trust and confidence but without always defining these terms. Unsurprisingly, in the absence of definitions, measuring trust and confidence and, for that matter, respect and love, is not yet possible and so is beyond scientific scrutiny. In part these qualities may be proxies for lack of fear and an overwhelming positive affect in the presence of humans. As noted earlier in the section on socialization, it is also possible that animals living alongside humans may treat them as attachment figures. There is some neurological evidence that attachment figures in humans act as a safety signal, reducing the experience of pain (Eisenberger et al. 2011). It has been suggested that dogs form a unique attachment bond with their human owners that may be similar to a mother–infant relationship (Topal et al. 1998). More research is required to identify the type of attachment dogs have with their owners and whether it is analogous to the mother–infant attachment bond in humans and dogs. Meanwhile, this line of inquiry opens up new possibilities for cognitively forming bonds with animals similar to the trust and security offered by good human parents, with the aim of creating a safety signal, complete with an enhanced ability to inhibit fear and pain experiences for those animals. Such a bond would

not only be rewarding, but also valuable in animal management and husbandry practices.

A number of equine practitioners working within the Natural Horsemanship training philosophy emphasize the development of a relationship of trust based on the leadership qualities of the trainer (Parelli 2003; Roberts 1997; Anderson & Hendrickson 2004). A critical component of this leadership is the apparent ability of the trainer to protect the horse from danger (Parelli 2003; Miller & Lamb 2005). Trainers in this field cite evidence from personal observations of feral and domestic horses, and claim that it is possible for humans to successfully mimic the qualities of equine 'leaders' such that in training situations horses will choose to remain with the trainer rather than flee when exposed to fearful stimuli (Roberts 1997; Miller & Lamb 2005).

Conclusions

Animals said to have confidence in and regard for their handlers may value the relative safety they afford. Whether humans are able to become conditioned signals for safety warrants further investigation. Perhaps viewing the relationship between a trained animal and a human as one of trust that should be carefully nurtured and maintained would encourage those who work and live with animals to be mindful of preserving that sense of safety they are striving to create. Distilling trust as, in part at least, a safety signal afforded by humans may offer a significant step forward in demystifying and, therefore, defining and even measuring hitherto mysterious elements of human–animal relationships.

Acknowledgements

The authors thank Erin Sigley and Alissa Sannikova for early discussions of fear in horses that took place during their time in PM's laboratory.

9.0. Discussion and Future Directions

As the profile of animal welfare grows in the public conscience, there is an increasing demand to understand dogs' behaviour so that humane treatments and methods for behavioural change can be sought. The work presented here explored both validated and novel approaches to measuring dog personality, and has built foundations for a more comprehensive framework for understanding and predicting dog behaviour.

9.1. Judgement bias

Judgement bias studies on animals have been of increasing interest in recent years as an objective measure of affective state, and therefore, as a possible indicator of welfare. Evidence from studies where positive or negative judgement biases have been induced with treatments assumed to alter affective state suggests that judgement bias may have a future in welfare assessments. Some studies have shown differences in judgement bias within a population under the same housing and management conditions. These differences in judgement bias are associated with some behavioural measures, suggesting that personality may also play a role in judgement bias. Correlations between personality and judgement bias may have applications in welfare, training, and selection of dogs for the right homes or jobs. This project laid some groundwork for investigating how judgement bias may relate to personality and be used in training and managing dogs.

9.1.1. Apparatus

The central focus of this project was developing an automated apparatus for training dogs in a discrimination task to test their judgement bias. This is the first study to have used an automated, auditory discrimination task in judgement bias testing. Auditory signals were chosen because of the ease of presenting a large range of probes. Other studies on dogs have used a spatial (Mendl 2010a; Müller et al. 2012) or visual discrimination (Burman et al. 2011) task. Dogs

appeared to learn the spatial task most quickly (21-61 trials), followed by the visual discrimination (30-200), with the auditory discrimination taking considerably more trials than the visual discrimination (at least 288). That said, the apparatus used in this study could present auditory cues automatically and thus cycle through 48 trials and three breaks in 24 minutes whereas the other two tasks required manual resetting by a researcher after each trial. Despite the longer task acquisition time, the auditory discrimination is highly suited to an automated apparatus. The addition of a touch screen would allow visual discriminations, but would increase the cost of building the unit. Judgement bias testing of dogs in previous studies also differed to the current study in the reward used (small quantity of food vs 1-5mL of lactose-free milk), and negative outcome (empty bowl vs 1-5mL of water). The advantage of delivering a tangible outcome in association with the negative signal is that it can't be mistaken by the dog as a failure for targeting to elicit a response, and the response that is elicited is similar to that elicited when the target is touched after a milk tone. The delivery of a third substance after probe tones would eliminate any non-responsive targeting. For example, milk for the positive outcome, milk laced with a bitter substance for the negative outcome, and water for probe outcomes. This may be a worthwhile variation to explore in future research in order to minimise learning artefacts in the training and testing.

Six versions of the apparatus were trialled during the course of the project, and the programming was revised three times. Diagrams illustrating the changes made between versions are shown in **Appendix 1**. Three of the apparatus versions were never used with dogs as they contained problematic features that had to be addressed first. These are not shown in **Appendix 1**. The major changes made between versions 1.1 and 1.2 of the apparatus were the incorporation of intravenous (IV) bags as reservoirs that were easier to mount and clean, and the addition of an audio volume control after six dogs were excluded from the first pilot study due to an aversion to the volume of the tones. The programming was also tweaked to include a new training phase with a reinforcement rate between that of TP2 and TP3 to address signs of frustration in the dogs when transitioned to TP3. The volume of milk and water delivered

was also halved to avoid possible satiation. The apparatus underwent a major design change after the second pilot study to address physical stability problems and reduce the assembly and disassembly times. New pumps were incorporated that were quieter, faster, and smoother. The new design considerably improved access to components for maintenance. The programming also underwent a major change between versions 1.2 and 2.0. The inter-trial interval (ITI) was reduced from 30s to 20s to avoid dogs' losing interest in the apparatus while waiting for the next cue, and to enable the delivery of more cues within the 5-minute training blocks. Versions 1.x of the apparatus delivered the nine probes once during judgement bias tests, offering no repetition within tests. The data were too sparse to test statistically. In Versions 2.x of the apparatus, the reduced ITI enabled the presentation of all nine probes twice within a single cognitive bias test while still having probes constitute less than half of the cues delivered within a judgement bias test.

A detailed description and map of the circuitry used and finite state machine diagrams describing the training phase program structure are shown in **Appendix 2**. Versions 2.0 and 2.1 were not tested on dogs. Version 2.2 was the final version and was used to collect the data presented in Chapter 5. The design hid all delicate components from oral exploration by dogs, and the target was changed from a movable target that was set at dog shoulder height to a stationary target at ground level. This latter change was made to simplify the design and improve stability. The target was set at an angle of approximately 45 degrees to discourage debris or liquid from collecting on it and to allow dogs some flexibility in their angle of approach to the target. Some dogs learned to operate the apparatus from a reclining position, suggesting that standing with the head hanging towards the ground was not the most comfortable position to hold for several minutes. One dog, a greyhound, appeared to find it uncomfortable to drop the head towards the target and trays even for a few moments. This dog was unable to lie down comfortably and still be able to access the target due to the shape of its chest and length of its legs. The apparatus was therefore placed on top of a wooden pallet that was 15cm high and the dog was able to comfortably access the target and trays. As such, the final apparatus

design is suitable for the majority of dogs, but some tall breeds may require the apparatus to be elevated. If a similar apparatus were to be left in a dog's home environment for an extended period, it is recommended it be mounted on a wall or other sturdy, vertical surface so that it could be set at a height that encourages the dog to interact with it.

It is important to note that exactly how dogs perceive auditory tones is unknown. The response latency graphs for each dog is shown in **Appendix 3**, and one feature that is consistent to varying degrees in most of the graphs is a dip in latency at around Tone 8 (Probe 7). The frequency response of any loudspeaker is highly dependent on the box, and so is the harmonic distortion. This has been extensively studied and there are measures for it known as Thiele-Small parameters (e.g. Beranek & Mellow 2012). A discussion of this is well beyond the scope of this thesis, but at its simplest level, in this case the relevance of harmonic distortion means the output consists of both the desired tone and some tonal resonance. Probe 7 and the milk tone (Tone 1) in Protocol A may be harmonically related, meaning that, to the dogs, Probe 7 may sound more like the milk tone than some probes closer in tone to the milk tone (e.g. Stoll & Parncutt 1987). For dogs on Protocol B, Probe 2 may have sounded more like the water tone than probes closer in tone to the water tone. If this were the case, it's possible the tipping point was not accurately identified by the data. This would ideally be quantified, but how dogs perceive tones may differ depending on their size, head shape and the environment they have been raised in.

The automated, portable device lends itself to collecting data on a large number of dogs using minimal resources. It is easy to teach people how to operate it and the programming allows for it to simply be switched on and left with the dog. Many dogs appeared to enjoy interacting with it, and some owners (perhaps facetiously) offered to buy it. It could be further developed to allow dogs to interact with a touchscreen device to learn discrimination and categorisation tasks with cognitive bias and memory tests in different contexts. This approach may allow for repeated testing of cognitive bias to enable it to be used to provide a reliable measure of affective state in dogs.

9.1.2. Repeated Testing

Work on sheep highlighted that one limitation of judgement bias may be in repeated testing, as sheep responded less to probes over time (Doyle, Vidal, et al. 2010b). Although this effect has been sought and not found in dogs (Mendl, Burman, et al. 2010c), it was reported in Chapter 5 that dogs tested with the auditory version developed for this project were significantly less likely to touch the target in their third test than their first. Four Assistance Dogs Australia dogs were available for a second judgement bias test during the current course of data collection. Three were started four months after their first round of judgement bias tests and one was started six months after. All four dogs were started on TP3 on their second round, and their judgement bias tested when they met the same criterion they had reached in the first round. Two of the three dogs started at four months after the first tests achieved this in four sessions, and the remaining dog completed two sessions and then the targeting behaviour extinguished. The dog tested six months after the first tests took six sessions to meet the judgement bias testing criterion. All three dogs that finished the second round of tests showed higher variability scores than they did in the first round of testing, indicating faster decisions and, for two dogs, greatly elevated optimism. The response latency graphs for these dogs from the first and second tests are shown in **Appendix 3**. These results could not be analysed due to low numbers, but suggest that re-testing with the same procedure may produce very different results. Nevertheless, these results also suggest that the dogs may retain the discrimination task well over time.

9.1.3. Interpretations of judgement bias data

Interpreting judgement bias data in animals may be more complicated than has often been supposed. This section will cover factors that may influence the data that was collected and offers alternative interpretations of the data both from possible confounding influences of learning theory and from unintended influences on affective state from the training and testing design. A general consideration of approaches to interpreting judgement bias that have been used

in previous discussions and their possible disadvantages is followed by a discussion of specific potentially confounding factors encountered in the current study.

Previous approaches to interpretation

Previous studies of judgement bias data in animals assume a bias is present only where the average latency deviates from an expected straight line relationship between the average latencies associated with the positive and negative signals (e.g. Mendl et al. 2010a; Müller et al. 2012). Using this criterion, a general positive judgement bias was reported by Mendl et al. (2010a) and Burman et al. (2011) and mostly no judgement bias was reported by Müller et al. (2012). This difference was suggested to be either an artefact of where the dogs were sourced (kennel vs public) or personality differences (Müller et al. 2012). In contrast, dogs from this study were from varied sources and most showed early tipping points, which would be interpreted by the deviation from a straight line relationship criterion as pessimistic. This is in spite of the cost of an incorrect choice being arguably lower in this study than in earlier studies given the dogs did not have to traverse several metres in order to touch the target and check the trays. This interpretation perhaps suits a relatively simple frequentist statistical approach because it is based on detecting differences in average response latency between probes and learned signals. There are few probes and dogs are pooled into groups, making it easier to detect differences compared to the approach used in the current study of many probes and dogs pooled into just one group. However, it could be argued that this approach is overly broad and sacrifices detail for the semblance of statistical power where sample sizes are small and data reduced to excessively broad patterns. A recent, well-designed study by Titulaer et al. (2013) may demonstrate why this sacrifice may be great. Dogs kennelled short-term and long-term were used in a matched design and their judgement bias tested along with measurement of creatinine:cortisol ratios, behavioural observations, and information from kennel workers on how dogs behaved and appeared to be coping in the kennel environment. Despite the thoroughness, no significant differences were detected using frequentist statistics between short-term kennel dogs and long-term kennel dogs, but a high

level of variability between dogs was recorded both in creatinine:cortisol ratios and judgement bias tests. The traditional frequentist approach fails to take into account possible differences in discriminatory ability, which are suggested in the mathematical approach to interpretation reported in Chapter 5 and in many cases made a profound difference to how the dogs were categorised in terms of optimism or pessimism. While the results of Titulaer et al (2013) may also be explained by kennelling time not being linked to welfare or affective state, they note that it is also possible that individual differences in the way dogs respond to the kennel environment may overshadow the effect of kennelling time in this particular group of dogs. Chapter 5 demonstrated how an interpretation from raw numbers alone may offer a more sophisticated view than a purely statistical approach. Further research comparing the mathematical approach with a statistical approach would help direct future design, analysis and interpretation of judgement bias data from animal studies. However, other potential confounding factors on judgement bias results remain. Reinforcement rate, motivation and the test conditions themselves could influence either affective state or judgement bias results.

Reinforcement rate

Reinforcement rate in this study was stepped down in stages, from as many as a dog could obtain in a 4-5 minute training block in TP1 to 12 in a block in TP2, 8 in a block in TP2A, and approximately 6 in a block (50% of cues presented) in TP3. This appeared to be too low for seven out of the 29 dogs that made it to TP3, as shown by a decline in targeting in this phase. A further 3 dogs showed the same decline in response earlier in the training at TP2 and one at TP2A. The ratio of tones in the judgement bias test was 37.5% probe tones, and 31.25% milk and 31.25% water tones. This was similar to the ratio used in other judgement bias tests, (Mendl et al. 2010a; Burman et al. 2009; Lindström 2010; Doyle et al. 2010a; Matheson et al. 2008), although Burman et al. (2011) used 20% probes. As such, reinforcement rate drops again in judgement bias tests. This was done to allow the presentation of all probes twice and the additional presentation of an equal number of milk and water tones during judgement bias tests. This is standard procedure, but it's possible the reinforcement rate could

affect the response rate. There is some evidence that more probable signals produce faster response latencies where outcomes are equal (see Katzner and Miller 2012 for review). The standard structure of judgement bias tests in animals present no class of signals that are more probable than any other, but this assumes the animal categorises probes and negative signals separately. We have no way of knowing if unreinforced probes may be perceived the same as negative/neutral signals, particularly in methods where neutral signals are associated with a lack of a positive outcome, which makes them no different to unreinforced probes. An alternative test structure considered was designed to maintain reinforcement rate between TP3 and judgement bias testing, but would have required more milk tones presented than water tones within a test. It was thought this might affect the dogs' discrimination abilities. It may be beneficial to explore the effect of reinforcement rate in discrimination training on subsequent judgement bias results.

Motivation

Potential individual differences in the motivation for lactose-free milk as a reward were not considered directly in this study. The Cox's proportional hazards model showed that some dogs were faster and more likely to touch the target after any cue than others, and the criterion for classifying dogs as pessimistic was long average latencies precluding a 100% increase in latency that would indicate the tipping point. It could be argued that the pessimistic dogs were simply not strongly motivated to obtain milk rewards. This seems unlikely given dogs were typically within a metre of the apparatus when a tone sounded and often did not need to even take a step to bend their head and touch the target. The long latencies could alternatively be explained by a lower response rate to milk tones. This may be an artefact of pessimism, as it's possible that pessimistic dogs with their bias towards expecting negative outcomes would be more likely to mistake milk tones for a signal of a negative outcome, or default to not responding if they were uncertain. The response latency graphs of some of those dogs show that there is a higher standard deviation at the milk tone than for dogs that did have a tipping point. This may hint at dogs failing to respond to some milk tones whilst responding quickly to others. Another possibility is that

these dogs had poor discrimination skills in general and made more errors across all cues. This would not necessarily show up in an elevated likelihood of touching the target in the Cox's proportional hazards model if there were a bias towards Type II errors in particular. An active choice task instead of a go/no-go task may aid in determining the influence of motivation on results.

Influences of affective state on results may have been unintentionally introduced through the training and testing procedure. Firstly, the training itself may have had a broad influence on the affective state of the dogs involved. Dogs have been shown to have a natural tendency to attend to human signals and look to humans for help in problem solving (Miklósi et al. 2003; Gácsi, Gyoöri, et al. 2009a). The experiment and apparatus were therefore designed to minimise interaction between dogs and the human tester in an attempt to standardise the training and testing by removing the human component as much as was feasible.

Nevertheless, dogs may have welcomed the proximity of a human tester and the inevitable human interaction involved even though it was minimal. This may have provoked an improvement in mood and a more positive affective state associated with the apparatus and training procedure. Many of the dogs in the study were housed in a kennel situation and may have enjoyed the relief from the kennel that the appearance of the human tester and subsequent training heralded. Although there were still clear differences in how the dogs interpreted ambiguous cues, an enriching effect cannot be ruled out. Such an effect is predicted to have differing strengths in different dogs given the difficulties discussed in Chapter 1 of finding universally positive or negative stimuli and differences in how individuals perceive such stimuli. A refinement of the apparatus design to exclude human presence completely may aid in interpretation of judgement bias data. Similarly, installing the apparatus in the dogs' kennel or home so that they had access to it all the time would likely minimise the possible effects of novelty. It is conceivable the apparatus could be programmed to respond to the dog's input so that the dog could start a training session autonomously by touching the target.

Possible confounding influences on judgement bias

It is also possible dogs may experience a more positive affective state upon mastering the discrimination task. In future studies, the influence of training outcomes on a dog's affective state could be investigated by collecting more comprehensive data that include variables such as displacement behaviours, ear or tail positions, un-cued targeting, and general activity and response latency. The current rudimentary data revealed significant differences in responses between dogs, suggesting that if there was an effect, it is likely to either be negligible or of different magnitudes depending on the dog. It is recommended that future research incorporate data on dog personality, as this may affect the learning process and, in turn, reveal predictors of how ambiguous signals are interpreted. Correlating personality measures with behaviour during training and judgement bias testing results may aid in identifying indicators that may help to expose any effect of training progress on affective state.

As discussed in the literature review in Chapter 1, efforts to validate judgement bias as an indicator of affective state have commenced in some species. For various reasons, it seems it may be difficult to validate judgement bias with physiological measures such as heart rate variability or cortisol concentrations. For example, it has been pointed out that different affective states may produce the same physiological responses, and may not correlate well with the strength of behaviours observed (Paul et al. 2005). High variability in baseline ratios of urinary cortisol:creatinine concentrations has been reported in dogs, and suggests that these measures may be influenced by individual differences between dogs (Titulaer et al. 2013). This was discussed in the coping styles literature review (section 1.3.5.), and such differences may or may not correlate with judgement biases.

The obstacles to interpretation discussed in the previous pages demonstrate that the judgement bias methodology used in this project lacks validation. It is not entirely clear exactly what is being measured by judgement bias data in the first place. The results from this study suggest that personality may play a large role, and this is one area of judgement bias research that has received little attention so far. Further research in seeking correlations between behaviour, judgement

bias measures, and personality traits may help to identify the full breadth of meaning in judgement bias data and thus guide research into validation of this measure.

9.1.4. Development of additional indicators

The behaviour dogs displayed during training and judgement bias tests may help to reveal their personality and predict variability scores in judgement bias tests. The strongest candidate for behaviour indicative of judgement bias results may be displacement behaviours. Displacement behaviours are defined as activities that are out of context or apparently irrelevant to the ongoing activity (Tinbergen 1951). They are thought to indicate a state of conflict or frustration (see Maestriperi 1992 for review), and have been associated with distress in dogs (Beerda et al. 2000; Blackwell et al. 2010). Mild displacement behaviours such as lip-licking, sniffing the ground, or turning away from the apparatus after receiving water were common during judgement bias training and testing in this study, but some dogs displayed additional displacement or disengagement behaviours such as yawns, whines, and actively moving away from the apparatus. Those dogs in the latter group (n=4) tested pessimistic in three cases and moderately pessimistic in one. There were four dogs in the pessimistic group. The one that did not yawn or whine paced in circles and had a generally low response rate. It would be worthwhile investigating displacement behaviours in dogs further and seek correlations with other personality traits or with judgement bias results.

The apparatus may be used to collect secondary data that could indicate personality traits or optimism. Extinction curves and rates of un-cued targeting are two objective measures easily obtained from the apparatus log that may be revealing. The discussion of the coping styles literature in Chapter 1 included the suggestion that impulsivity may be linked with proactive coping (Cervantes & Delville 2007). There may be a correlation between rates of un-cued targeting and variability scores in judgement bias testing. Conversely, it was also found in a study of rats that individuals expected to be in a negative affective state made faster decisions on ambiguous signals than controls, and this may reflect

impulsivity, which in humans has been associated with trait anxiety and major depression (Brydges et al. 2012). Extinction curves may be related to persistence, which in turn may be a trait of optimistic dogs. The rate of decline in un-cued targeting may represent an extinction curve. It is anticipated that a high level of resilience to a lack of reinforcement may be part of what makes optimistic dogs take more chances or perhaps see opportunities where other dogs see risks.

It is possible physical activity may be correlated with optimism or pessimism in dogs. There is some evidence from the human literature that optimism or positive affect may be correlated with increased physical activity and sedentary behaviour with stress (Taylor et al. 2004; Nguyen-Michel et al. 2006; Kavussanu & McAuley 1995; Palomo et al. 2008). Chronically stressed dogs in kennel environments show higher levels of locomotor activity, and respond actively to external stimuli (Beerda et al. 2000). In contrast, locomotion was found to be similar in a genetically nervous line of pointer dogs to normal pointer dogs in non-stressful conditions, but significantly lower in stressful situations (Klein & Uhde 1988). In addition, low physical activity is associated with depression and anhedonia in rats (Willner 1997), which led to the development of active choice tasks in judgement bias studies in animals (Matheson et al. 2008). Measuring physical activity in dogs alongside judgement bias may account for this potentially confounding effect. The paper presented in Chapter 6 investigated the use of digital accelerometers to measure physical activity in dogs. Cheap, commercially available uniaxial accelerometers were compared to expensive triaxial accelerometers. The conclusion from the uniaxial and triaxial accelerometer comparison was that the models could not be used interchangeably. Given the expensive triaxial accelerometers have been validated, this is the model that should preferably be used in scientific studies. Triaxial accelerometers are considered superior because they record movement along three axes rather than just one axis as is the case for uniaxial accelerometers. Inexplicably, the results from this study showed that uniaxial accelerometers used on dogs recorded more steps than triaxial models, despite the uniaxial models recording only movement in one axis. As such, arranging

three uniaxial accelerometers in an x,y,z configuration is logical, but unlikely to improve the accuracy of the measured activity. Agreement between the two models differed depending on bodyweight of dogs and the activity taking place. It may be possible to develop an index to account for bodyweight in uniaxial accelerometers, but they may be unsuited to free, unstructured activity where agreement between devices was most disparate.

9.1.5. A note about terminology

The paper presented in Chapter 7 outlined how affective state is considered to consist of two components: emotional valence and arousal. Previous studies on cognitive bias in animals sometimes refer to it as a measure of affective state (e.g. Bateson et al. 2011; Mendl et al. 2010a), but in other cases have presented cognitive bias as a measure specifically of emotional valence (e.g. Brydges et al. 2011; Doyle et al. 2011; Burman et al. 2008a). The response landscapes were generated on the assumption that arousal and emotional valence are independent, but this has not been tested to the author's knowledge. If they are not independent, the emotional valence measured in cognitive bias tests may incorporate arousal, and therefore would not be a measure of emotional valence strictly speaking. If they are independent, it's possible that because of the nature of the judgement bias tests requiring physical action, an arousal effect may still be observed. For example, cortisol concentrations in dogs fluctuate during the day (Kolevska et al. 2003; Klein & Uhde 1988) and a dog may be more likely to touch the target after any tone if they are standing up than if they are lying down, or if they have just come from a run in a yard compared to if they have just come from their kennel, or if it is early in the morning compared to midday. Therefore, in this study, judgement bias has been considered to be a measure of emotional valence independent of arousal.

9.2. Dog personality research

The literature review of personality research in animals in Chapter 1 raised several problems with the validation of personality measures or dimensions and indicated that a more mathematical approach to personality research in animals

may help to solve some of these problems. It is envisioned that the dog personality survey used in this project (showed in **Appendix 4**) partnered with the ample data collected during the course of judgement bias training and testing could be used to develop objective, quantitative indicators of dog personality. The results of the survey provide many paths for further inquiry and reveal variables for further investigation when building predictive models of dog behaviour, such as breed or breed group, age, sex and reproductive status. There is clearly a need for large amounts of data to trawl for patterns in behaviour. Surveys represent the means to collect large amounts of subjective personality data with comparatively little time commitment from researchers. Citizen science projects such as the recently launched [Dognition](#) are another means to potentially collect large amounts of data. An expansion of the survey to incorporate questions addressing the dog's living conditions and daily activities may be valuable in investigating why dogs might display the personality or judgement bias recorded for them, but any change to the survey would require another factor or principal components analysis to ascertain whether loadings from survey questions are still on the same components as reported in this study.

Adapting the apparatus to take advantage of readily available touchscreen devices may enable the large scale collection of data that, in tandem with subjective personality data collected via the expanded survey, would move the dog personality field out of the exploratory phase and into behavioural prediction.

9.3. The dog-human dyad

Taken together, Chapters 2 and 7 describe both how misunderstandings between dogs and humans may arise and the broader impact this may have on training with methods derived from operant conditioning. The paper presented in Chapter 2 highlighted that effective and safe relationships between dogs and humans may hinge on the human's ability to interpret dog body language and correctly identify their motivations. Dogs frequently communicate with humans

using elements from their own social ethogram, yet this is rarely reciprocated in the way humans initiate interactions with dogs using elements from the human social ethogram (e.g. voice commands). The resultant potential for miscommunication may leave both humans and dogs confused, threatened, or uncertain of how to behave, which is highly likely to impact on their affective state. A dog that regularly struggles to interpret human behaviour particularly in contexts outside of training may develop a negative judgement bias towards human-related signals. It may be that in households where play and training are not regular activities, a dog's interactions with humans may occur mostly in contexts where the role of learning theory in typical behavioural responses is relatively small, and the potential for humans to behave in ways that do not have a strong analogue in the canine ethogram is relatively high. For example, common contexts for human-dog interactions outside of training and play revolve around feeding, grooming, and veterinary procedures. Dogs certainly have the ability to learn to interpret human behaviour and signals, and are most likely to learn this from the specific humans they interact with most often (Coutellier 2006), and may thus be plunged into uncertainty when interacting with unfamiliar humans. We may see hints of this explanation in the data pertaining to a reduction in boldness with age in dogs presented in Chapter 4 which suggest that dogs may learn over time to approach strangers less often and engage in play with dogs or humans less often, and may become more fearful in general as they get older.

Miscommunications outside of training may also carry over into training contexts via a form of emotional conditioning. The history a dog has both with humans in general and a specific trainer may facilitate the development of a habitual emotional state encompassing both valence and arousal associated with humans or a specific trainer so that it can essentially be cued by the presence of the human trainer. The paper presented in Chapter 7 outlines how such an advent may affect training using operant conditioning. For example, if a human's interactions with a dog on a daily basis feature the dog regularly acting to avoid aversive stimuli (e.g. grooming, restraint or threats to desired resources), the dog is likely to approach training from a negative affective state with a stronger

interest in avoiding aversive experiences than obtaining access to reinforcers. If arousal is considered a state of preparedness for action, it would follow that the intensity and frequency of the aversive situations dogs may wish to avoid in association with their humans may affect the level of arousal they typically experience in association with those people. The presence of the caregiver may predict a need to be ready to engage in coping strategies. Conversely, if the relationship between the human and dog frequently involves calm reassurance and stroking, the dog may approach a training session with that human in a state of calm expectance typified by low arousal and positive affect. Of course, these examples represent simplified relationships in the dog-human dyad and it is more likely interactions between a dog and humans encompass broad ranges of associated arousal and affective state. Nonetheless, it is expected there would be a net effect representing most common arousal and affective state associations. The theory behind this is covered in Chapter 7, but from a practical standpoint may be seen as the importance of developing relationships with dogs based on access to reinforcers, control of aversive experiences, and consistency in communication. These three principles apply both to interactions where learning theory does not play a major role and in training scenarios where it does. The response landscapes show how ready access to reinforcers may improve training outcomes through improving affective state and encouraging optimal arousal levels. Consistency in communication may be achieved through the use of clear cues and optimal timing, both considered cornerstones of effective animal training (McGreevy & Boakes 2007).

Chapter 8 leads on from this with a review of safety signals and how they have been and may in future be used in animal training. The presence of a safety signal according to the theory discussed in Chapter 8 should serve to lower arousal. This is likely to reduce the frequency of fear-related behaviour, including aggression in dogs, and as shown in the response landscapes of Chapter 7, a means to reduce arousal particularly where the animal's affective state may be negative is likely to increase the effectiveness of training with operant conditioning methods. The effect of a safety signal on affective state is unknown, but may depend on the type of safety signal. For example, attachment

figures in humans are held to be safety signals (Eisenberger et al. 2011), and it would follow that the presence of an attachment figure may be associated with a positive affective state. Further research into the types of attachments dogs form with humans using the response landscapes to incorporate net effects of arousal and affective state may guide the planning of interactions to promote an association of optimal arousal and positive experiences with the human. The dog-human ethograms from Chapter 2 serve to highlight in what circumstances a safety signal may be of most benefit in the training and management of dogs by identifying the contexts in which there may be a deficit in analogues between the dog social ethogram and typical human behaviour towards dogs, such as grooming and veterinary procedures.

The paper in Chapter 8 also suggests ways safety signals may be trained and used operantly in dogs. Tortora's (1983) method involved the use of an electronic shock, but more modern training methods may be training safety signals simply through low-intensity exposure to stimuli the dog already finds aversive and cuing a retreat and thus avoidance. This offers a possibly more humane method of training safety signals in dogs that could be generalised and used to lower arousal and/or signal relaxation. Naturally occurring safety signals were also discussed in Chapter 8, pertaining mostly to horses as a herd animal. This may not be as ethologically relevant for dogs, but nonetheless deserves further investigation. It may help to explain why dogs' negative reactions may be stronger in some circumstances than in others with similar stimuli present, and therefore may aid in predicting behaviour.

Chapters 2 and 7 both introduced tools that may be used to aid in predicting dog behaviour in contexts pertaining to common dog-human interactions. The dog-dog social ethogram used to compare and contrast with the presented dog-human and human-dog social ethograms provide the means to identify where the principles of access to reinforcers, control of aversive experiences and clear and consistent communication may be regularly violated in day-to-day life. The response landscapes may be used to follow the effects such violation may have in training with operant conditioning, and furthermore, may be used in reverse to

identify when operant conditioning may not be as effective as anticipated and provide a framework to interpret failures in training, taking into account affective state and arousal and thus informing where changes may be welcome in all contexts of the dog's life rather than just training. Both these tools could be expanded in the future by collecting more data. The ethograms could be integrated with data collected on the body language of accomplished dog handlers and trainers, leading to an understanding of the quantifiable aspects of good dogmanship. This ties naturally with the response landscapes, which may in turn be refined through the collection of data to populate the landscapes and take them beyond the theoretical.

Both tools could benefit from the integration of personality data to account for some of the variation seen in dog behaviour. The addition of affective state data from judgement bias tests may also inform predictions of behavioural variability. A Bayesian model based on probabilities may be the logical next step in bringing observations and theory covering the diverse influences on behavioural variability together into a useful, predictive model. Such a model would require large amounts of data and engenders further consideration of citizen science projects.

Conclusions

This thesis has laid the foundations for the integration of several tools to aid in the understanding and research of dog personality and behavioural variability. The dog-human ethogram highlighted difficulties in communication between dogs and humans from an ethological perspective. The personality survey identified unambiguous influences on personality that should guide future research and may be used as a tool to explore relationships between everyday life and judgement bias. The judgement bias test itself results in a rich collection of data that may be applied to welfare assessments as well as personality assessments. It also offers the easy opportunity to explore potential objective, numerical indicators of personality and welfare. Triaxial accelerometers have

been established as a superior tool to uniaxial accelerometers for measuring physical activity, which may be the next step in judgement bias research. The response landscapes offer a visual, theoretical model conceptualising the effects of arousal and affective state on operant conditioning, which is hoped to aid in attaining training goals efficiently and with maximal consideration for the animal's welfare. Future research should prioritise validation of personality measures, identifying what is measured in judgement bias tests, refining the mathematical model to develop a judgement bias index, and populating the response landscapes with data. Further research into naturally occurring safety signals and the effects of safety signals on affective state in dogs as well as types of attachment present between dogs and humans may offer further insights into predicting dog behaviour and tools to proactively lower arousal and encourage a sense of safety in dogs.

References

- Abramson, CI, Armstrong, PM, Feinman, RA & Feinman, RD 1988, 'Signaled avoidance in the eye withdrawal reflex of the green crab', *Journal of the experimental analysis of behavior*, vol. 50, no. 3, pp. 483–492.
- Abrantes, R 1997, *Dog Language: An Encyclopedia of Canine Behavior*, Direct Book Service Inc., Wenatchee, WA.
- Aloff, B 2005, *Canine Body Language: A Photographic Guide Interpreting the Native Language of the Domestic Dog*, Direct Book Service Inc., Wenatchee, WA.
- Anderson, C & Hendrickson, A 2004, *Clinton Anderson's Downunder Horsemanship: Establishing Respect and Control for English and Western Riders*, Trafalgar Square, North Pomfret.
- Andersson, G 1996, 'The benefits of optimism: A meta-analytic review of the Life Orientation Test', *Personality and Individual Differences*, vol. 21, no. 5, pp. 719–725.
- Ascione, FR 2008, *The international handbook of animal abuse and cruelty: theory, research and application*, Purdue University Press, West Lafayette.
- Ashby, K 2001, 'Establishing the case! The facts of dog bite - Victorian public hospital injury surveillance', inpp. 1–10.
- Australian Companion Animal Council Inc. 2010, *Contribution of the Pet Care Industry to the Australian Economy - 7th Edition*, Australian Companion Animal Council Inc., Rockwell Communications Pty Ltd.
- Ågmo, A. et al., 2007. Social and sexual incentive properties of estrogen receptor or oxytocin knockout mice, *Genes, Brain and Behavior*, vol. 7, no. 1, pp. 70-77.
- Baker, TB, Piper, ME, McCarthy, DE, Majeskie, MR & Fiore, MC 2004, 'Addiction Motivation Reformulated: An Affective Processing Model of Negative Reinforcement.', *Psychological Review*, vol. 111, no. 1, pp. 33–51.
- Baldock, N & Sibly, R 1990, 'Effects of handling and transportation on the heart rate and behaviour of sheep', *Applied Animal Behaviour Science*, vol. 28, no. 1-2, pp. 15–39.
- Bamberger, M & Houpt, KA 2006, 'Signalment factors, comorbidity, and trends in behavior diagnoses in dogs: 1,644 cases (1991–2001)', *Journal of the American Veterinary Medical Association*, vol. 229, no. 10, pp. 1591–1601.
- Bar-Haim, Y, Lamy, D, Pergamin, L, Bakermans-Kranenburg, MJ & van IJzendoorn, MH 2007, 'Threat-related attentional bias in anxious and nonanxious individuals: A meta-analytic study.', *Psychological Bulletin*, vol.

133, no. 1, pp. 1–24.

- Barker, SB & Wolen, AR 2008, 'The benefits of human-companion animal interaction: a review.', *Journal of veterinary medical education*, vol. 35, no. 4, pp. 487–495.
- Barker, SB, Rogers, CS, Turner, JW, Karpf, AS & Suthers-McCabe, HM 2003, 'Benefits of Interacting with Companion Animals: A Bibliography of Articles Published in Refereed Journals during the Past 5 Years', *American Behavioral Scientist*, vol. 47, no. 1, pp. 94–99.
- Barnard, CJ & Brown, CAJ 1987, 'Risk-sensitive foraging and patch residence time in common shrews, *Sorex araneus* L', *Animal Behaviour*, vol. 35, no. 4, pp. 1255–1257.
- Baron, A & Galizio, M 2005, 'Positive and negative reinforcement: Should the distinction be preserved?', *The Behavior analyst / MABA*, vol. 28, no. 2, pp. 85–98.
- Barrett, LF, Mesquita, B, Ochsner, KN & Gross, JJ 2007, 'The experience of emotion', *Annual Review of Psychology*, vol. 58, p. 373.
- Bateson, M & Matheson, S 2007, 'Performance on a categorisation task suggests that removal of environmental enrichment induces "pessimism" in captive European starlings (*Sturnus vulgaris*)', *Animal Welfare*, vol. 16, no. Supplement 1, pp. 33–36.
- Bateson, M, Desire, S, Gartside, SE & Wright, GA 2011, 'Agitated Honeybees Exhibit Pessimistic Cognitive Biases', *Current Biology*, vol. 21, no. 12, pp. 1070–1073.
- Batt, L, Batt, M, Baguley, J & McGreevy, P 2010, 'Relationships between puppy management practices and reported measures of success in guide dog training', *Journal of Veterinary Behavior: Clinical Applications and Research*, vol. 5, no. 5, pp. 240–246.
- Bauer, EB & Smuts, BB 2007, 'Cooperation and competition during dyadic play in domestic dogs, *Canis familiaris*', *Animal Behaviour*, vol. 73, no. 3, pp. 489–499.
- Beerda, B, Schilder, M & van Hooff, J 1997, 'Manifestations of chronic and acute stress in dogs', *Applied Animal Behaviour Science*, vol. 52, no. 3-4, pp. 307–319.
- Beerda, B, Schilder, M, van Hooff, J, De Vries, H & Mol, J 2000, 'Behavioural and hormonal indicators of enduring environmental stress in dogs', *Animal Welfare*, vol. 9, no. 1, pp. 49–62.
- Beerda, B, Schilder, MBH, Van Hooff, JARAM, De Vries, HW & Mol, JA 1999, 'Chronic Stress in Dogs Subjected to Social and Spatial Restriction. I. Behavioral Responses', *Physiology & Behavior*, vol. 66, no. 2, pp. 233–242.

- Bennett, MJ & Coon, E 1966, 'Mellituria and Postprandial Blood Sugar Curves in Dogs After the Ingestion of Various Carbohydrates with the Diet', *The Journal of Nutrition*, vol. 88, pp. 163–168.
- Benus, RF, Bohus, B, Koolhaas, JM & van Oortmerssen, GA 1989, 'Behavioural strategies of aggressive and non-aggressive male mice in active shock avoidance', *Behavioural Processes*, vol. 20, no. 1-3, pp. 1–12.
- Benus, RF, Bohus, B, Koolhaas, JM & van Oortmerssen, GA 1991, 'Heritable variation for aggression as a reflection of individual coping strategies', *Cellular and Molecular Life Sciences*, vol. 47, no. 10, pp. 1008–1019.
- Benus, RF, Daas, den, S, Koolhaas, J & Van Oortmerssen, G 1990, 'Routine Formation and Flexibility in Social and Non-Social Behaviour of Aggressive and Non-Aggressive Male Mice', *Behaviour*, vol. 112, no. 3, pp. 176–193.
- Beranek, LL & Mellow, T. 2012 *Acoustics: Sound Fields and Transducers*, Academic Press, Oxford, UK.
- Bethell, EJ, Holmes, A & Maclarnon, A 2012, 'Cognitive bias in a non-human primate: husbandry procedures influence cognitive indicators of psychological well-being in captive rhesus macaques', *Animal Welfare*.
- Bintz, J 1971, 'Between- and within-subject effect of shock intensity on avoidance in goldfish (*Carassius auratus*).', *Journal of Comparative and Physiological Psychology*, vol. 75, no. 1, pp. 92–97.
- Blackwell, E, Bodnariu, A & Tyson, J 2010, 'Rapid shaping of behaviour associated with high urinary cortisol in domestic dogs', *Applied Animal Behaviour Science*, vol. 124, pp. 112–120.
- Blackwell, EJ, Twells, C, Seawright, A & Casey, RA 2008, 'The relationship between training methods and the occurrence of behavior problems, as reported by owners, in a population of domestic dogs', *Journal of Veterinary Behavior: Clinical Applications and Research*, vol. 3, no. 5, pp. 207–217.
- Bland, JM & Altman, DG 2010, 'Statistical methods for assessing agreement between two methods of clinical measurement', *International Journal of Nursing Studies*, vol. 47, pp. 931–936.
- Bogdan, R & Pizzagalli, DA 2008, 'The heritability of hedonic capacity and perceived stress: a twin study evaluation of candidate depressive phenotypes', *Psychological Medicine*, vol. 39, no. 02, pp. 211–218.
- Boissy, A 1995, 'Fear and fearfulness in animals', *Quarterly Review of Biology*, pp. 165–191.
- Boissy, A, Manteuffel, G, Jensen, MB, Moe, RO, Spruijt, B, Keeling, LJ, Winckler, C, Forkman, B, Dimitrov, I & Langbein, J 2007, 'Assessment of positive emotions in animals to improve their welfare', *Physiology & Behavior*, vol. 92, no. 3, pp. 375–397.

- Bolhuis, JE, Schouten, WGP, Leeuw, JA de, Schrama, JW & Wiegant, VM 2004, 'Individual coping characteristics, rearing conditions and behavioural flexibility in pigs', *Behavioural Brain Research*, vol. 152, no. 2, pp. 351–360.
- Bolles, RC 1970, 'Species-specific defense reactions and avoidance learning.', *Psychological Review*, vol. 77, no. 1, p. 32.
- Bouton, ME 2007, *Learning and Motivation - A Contemporary Synthesis*, Sinauer and Associates, Sunderland, MA.
- Bower, G, Starr, R & Lazarovitz, L 1965, 'Amount of response-produced change in the CS and avoidance learning.', *Journal of Comparative and Physiological Psychology*, vol. 59, no. 1, pp. 13–17.
- Bradley, MM, Miccoli, L, Escrig, MA & Lang, PJ 2008, 'The pupil as a measure of emotional arousal and autonomic activation', *Psychophysiology*, vol. 45, no. 4, pp. 602–607.
- Bradshaw, J, Blackwell, EJ & Casey, RA 2009, 'Dominance in domestic dogs—useful construct or bad habit?', *Journal of Veterinary Behavior: Clinical Applications and Research*, vol. 4, no. 3, pp. 135–144.
- Bradshaw, J, Goodwin, D, Lea, AM & Whitehead, SL 1996, 'A survey of the behavioural characteristics of pure-bred dogs in the United Kingdom', *The Veterinary Record*, vol. 138, no. 19, p. 465.
- Brain, PF 2010, 'Aggression', in D Mills, J Marchant-Forde, PD McGreevy, DB Morton, CJ Nicol, C Phillips, P Sandoe, & RR Swaisgood (eds), *Encyclopedia of Applied Animal Behaviour Welfare*, CABI Publishing, Wallingford, Oxon, pp. 8–10.
- Brennan, FX, Beck, KD & Servatius, RJ 2003, 'Leverpress escape/avoidance conditioning in rats: safety signal length and avoidance performance.', *Integrative physiological and behavioral science : the official journal of the Pavlovian Society*, vol. 38, no. 1, pp. 36–44.
- Brilot, BO, Asher, L & Bateson, M 2010, 'Stereotyping starlings are more "pessimistic"', *Animal Cognition*, vol. 13, no. 5, pp. 721–731.
- Broadhurst, PL 1957, 'Emotionality and the Yerkes-Dodson law.', *Journal of Experimental Psychology*, vol. 54, no. 5, p. 345.
- Brown, DC, Boston, RC & Farrar, JT 2010, 'Use of an activity monitor to detect response to treatment in dogs with osteoarthritis.', *Journal of the American Veterinary Medical Association*, vol. 237, no. 1, pp. 66–70.
- Brown, DC, Boston, RC, Coyne, JC & Farrar, JT 2007, 'Development and psychometric testing of an instrument designed to measure chronic pain in dogs with osteoarthritis', *American Journal of Veterinary Research*, vol. 68, no. 6, pp. 631–637.

- Brown, DC, Michel, KE, Love, M & Dow, C 2010, 'Evaluation of the effect of signalment and body conformation on activity monitoring in companion dogs', *American Journal of Veterinary Research*, vol. 71, no. 3, pp. 322–325.
- Brydges, NM, Hall, L, Nicolson, R, Holmes, MC & Hall, J 2012, 'The Effects of Juvenile Stress on Anxiety, Cognitive Bias and Decision Making in Adulthood: A Rat Model' T Burne (ed), *PLoS one*, vol. 7, no. 10, p. e48143.
- Brydges, NM, Leach, M, Nicol, K, Wright, R & Bateson, M 2011, 'Environmental enrichment induces optimistic cognitive bias in rats', *Animal Behaviour*, vol. 81, no. 1, pp. 169–175.
- Burgdorf, J & Panksepp, J 2006, 'The neurobiology of positive emotions', *Neuroscience & Biobehavioral Reviews*, vol. 30, no. 2, pp. 173–187.
- Burman, O, McGowan, R, Mendl, M, Norling, Y, Paul, E, Rehn, T & Keeling, L 2011, 'Using judgement bias to measure positive affective state in dogs', *Applied Animal Behaviour Science*, vol. 132, no. 3-4, pp. 160–168.
- Burman, O, Parker, R, Paul, ES & Mendl, M 2008a, 'Sensitivity to reward loss as an indicator of animal emotion and welfare', *Biology Letters*, vol. 4, no. 4, p. 330.
- Burman, OHP, Parker, R, Paul, E & Mendl, M 2009, 'Anxiety-induced cognitive bias in non-human animals', *Physiology & Behavior*, vol. 98, no. 3, pp. 345–350.
- Burman, OHP, Parker, R, Paul, ES & Mendl, M 2008b, 'A spatial judgement task to determine background emotional state in laboratory rats, *Rattus norvegicus*', *Animal Behaviour*, vol. 76, no. 3, pp. 801–809.
- Callen, EJ 2004, 'Context preexposure influences the effectiveness of feedback stimuli in avoidance learning', *Behavioural Processes*, vol. 66, no. 1, pp. 35–42.
- Careau, V, Réale, D, Humphries, MM & Thomas, DW 2010, 'The Pace of Life under Artificial Selection: Personality, Energy Expenditure, and Longevity Are Correlated in Domestic Dogs', *The American Naturalist*, vol. 175, no. 6, pp. 753–758.
- Caro, TM 2005, *Antipredator defenses in birds and mammals*, University of Chicago Press, Chicago.
- Carpenter, RE & Summers, CH 2009, 'Learning strategies during fear conditioning', *Neurobiology of Learning and Memory*, vol. 91, no. 4, pp. 415–423.
- Carver, CS, Scheier, MF & Segerstrom, SC 2010, 'Optimism.', *Clinical Psychology Review*, vol. 30, no. 7, pp. 879–889.
- Cattell, RB & Korth, B 1973, 'The isolation of temperament dimensions in dogs¹', *Behavioral biology*, vol. 9, no. 1, pp. 15–30.

- Cändido, A, Maldonado, A & Vila, J 1991, 'Effects of duration of feedback on signaled avoidance', *Animal Learning & Behavior*, vol. 19, no. 1, pp. 81–87.
- Cervantes, MC & Delville, Y 2007, 'Individual differences in offensive aggression in golden hamsters: A model of reactive and impulsive aggression?', *Neuroscience*, vol. 150, no. 3, pp. 511–521.
- Chan, ADF, Nippak, PMD, Murphey, H, Ikeda-Douglas, CJ, Muggenburg, B, Head, E, Cotman, CW & Milgram, NW 2002, 'Visuospatial impairments in aged canines (*Canis familiaris*): The role of cognitive-behavioral flexibility.', *Behavioral Neuroscience*, vol. 116, no. 3, pp. 443–454.
- Chan, CB, Spierenburg, M, Ihle, SL & Tudor-Locke, C 2005, 'Use of pedometers to measure physical activity in dogs', *Journal of the American Veterinary Medical Association*, vol. 226, no. 12, pp. 2010–2015.
- Chang, ML, Yokoyama, JS, Branson, N, Dyer, DJ, Hitte, C, Overall, KL & Hamilton, SP 2009, 'Intrabreed Stratification Related to Divergent Selection Regimes in Purebred Dogs May Affect the Interpretation of Genetic Association Studies', *Journal of Heredity*, vol. 100, no. Supplement 1, pp. S28–S36.
- Christensen, JW, Malmkvist, J, Nielsen, BL & Keeling, LJ 2008, 'Effects of a calm companion on fear reactions in naive test horses', *Equine veterinary journal*, vol. 40, no. 1, pp. 46–50.
- Christianson, JP, Fernando, ABP, Kazama, AM, Jovanovic, T, Ostroff, LE & Sangha, S 2012, 'Inhibition of Fear by Learned Safety Signals: A Mini-Symposium Review', *Journal of Neuroscience*, vol. 32, no. 41, pp. 14118–14124.
- Cicala, GA & Azorlosa, JL 1985, 'Stimulus specificity in avoidance learning', *Learning and Motivation*, vol. 16, no. 1, pp. 83–94.
- Coppens, C & de Boer, S 2010, 'Coping styles and behavioural flexibility: towards underlying mechanisms', *Philosophical Transactions of the Royal Society B*, vol. 365, pp. 4021–4028.
- Coppinger, R & Coppinger, L 2001, *Dogs: a new understanding of canine origin, behaviour and evolution*, The University of Chicago Press, Chicago.
- Coppinger, R & Schneider, R 1995, 'Evolution of working dogs', in J Serpell (ed), *The domestic dog: its evolution, behaviour, and interactions with people*, Cambridge University Press, Cambridge, UK, pp. 21–51.
- Corder, K, Brage, S & Ekelund, U 2007, 'Accelerometers and pedometers: methodology and clinical application', *Current opinion in clinical nutrition and metabolic care*, vol. 10, pp. 597–603.
- Costa, PT & McCrae, RR 2006, 'Age changes in personality and their origins: Comment on Roberts, Walton, and Viechtbauer (2006).', *Psychological Bulletin*, vol. 132, no. 1, pp. 26–28.

- Coutellier, L 2006, 'Are dogs able to recognize their handler's voice? A preliminary study.', *Anthrozoos*, vol. 19, no. 3, pp. 278–284.
- Crouter, SE, Schneider, PL & Bassett, DR 2005, 'Spring-levered versus piezo-electric peodmeter accuracy in overweight and obese adults', *Medicine and Science in Sports and Exercise*, vol. 37, no. 10, pp. 1673–1679.
- D apos Amato, MR, Fazzaro, J & Etkin, M 1968, 'Anticipatory responding and avoidance discrimination as factors in avoidance conditioning.', *Journal of Experimental Psychology*, vol. 77, no. 1, pp. 41–47.
- Dalibard, GH 2009, 'Parameters influencing service dogs' quality of response to commands: Retrospective study of 71 dogs', *Journal of Veterinary Behavior: Clinical Applications and Research*, vol. 4, no. 1, pp. 19–24.
- De Boer, SF, Slangen, JL & Van der Gugten, J 1990, 'Plasma catecholamine and corticosterone levels during active and passive shock-prod avoidance behavior in rats: Effects of chlordiazepoxide', *Physiology & Behavior*, vol. 47, no. 6, pp. 1089–1098.
- de Ruiter, AJ, Koolhaas, JM, Keijser, JN, Van Oortmerssen, GA & Bohus, B 1992, 'Differential testosterone secretory capacity of the testes of aggressive and nonaggressive house mice during ontogeny', *Aggressive Behavior*, vol. 18, no. 2, pp. 149–157.
- Deci, EL & Ryan, RM 1985, *Intrinsic Motivation and Self-determination in Human Behavior*, Plenum Press, New York, NY.
- Denny, M 1983, 'Safety catch in behavior therapy: Comments on " Safety training: The elimination of avoidance-motivated aggression in dogs" by Daniel F. Tortora.'
- Depue, RA & Collins, PF 1999, 'Neurobiology of the structure of personality: Dopamine, facilitation of incentive motivation, and extraversion', *Behavioral and Brain Sciences*, vol. 22, no. 03, pp. 491–517.
- Destrez, A, Deiss, V, Belzung, C, Lee, C & Boissy, A 2012, 'Does reduction of fearfulness tend to reduce pessimistic-like judgment in lambs?', *Applied Animal Behaviour Science*, pp. 1–9.
- Dingemans, NJ & Wolf, M 2010, 'Recent models for adaptive personality differences: a review.', *Philosophical transactions of the Royal Society of London. Series B, Biological sciences*, vol. 365, no. 1560, pp. 3947–3958.
- Dinsmoor, JA 2001, 'Stimuli inevitably generated by behavior that avoids electric shock are inherently reinforcing.', *Journal of the experimental analysis of behavior*, vol. 75, no. 3, pp. 311–333.
- Dinsmoor, JA & Sears, GW 1973, 'Control of avoidance by a response-produced stimulus', *Learning and Motivation*, vol. 4, no. 3, pp. 284–293.

- Domjan, M 2010, *The Principles of Learning and Behavior Sixth*, Wadsworth Cengage Learning, Belmont, CA.
- Douglas, C, Bateson, M, Walsh, C, Bédoué, A & Edwards, SA 2012, 'Environmental enrichment induces optimistic cognitive biases in pigs', *Applied Animal Behaviour Science*, vol. 139, no. 1-2, pp. 65–73.
- Dow, C, Michel, KE & Brown, DC 2009, 'Evaluation of optimal sampling interval for activity monitoring in companion dogs', *American Journal of Veterinary Research*, vol. 70, no. 4, pp. 444–448.
- Doyle, R, Fisher, A, Hinch, G & Boissy, A 2010a, 'Release from restraint generates a positive judgement bias in sheep', *Applied Animal Behaviour Science*, vol. 122, pp. 28–34.
- Doyle, RE, Lee, C, Deiss, V, Fisher, AD, Hinch, GN & Boissy, A 2011, 'Measuring judgement bias and emotional reactivity in sheep following long-term exposure to unpredictable and aversive events', *Physiology & Behavior*, vol. 102, no. 5, pp. 503–510.
- Doyle, RE, Vidal, S, Hinch, GN, Fisher, AD, Boissy, A & Lee, C 2010b, 'The effect of repeated testing on judgement biases in sheep', *Behavioural Processes*, vol. 83, no. 3, pp. 349–352.
- Draper, TW 1995, 'Canine analogs of human personality factors', *Journal of General Psychology*, vol. 122, no. 3, pp. 241–252.
- Drews, C 1993, 'The Concept and Definition of Dominance in Animal Behaviour', *Behaviour*, vol. 125, no. 3, pp. 283–313.
- Duffy, DL & Serpell, JA 2012, 'Predictive validity of a method for evaluating temperament in young guide and service dogs', *Applied Animal Behaviour Science*, vol. 138, no. 1-2, pp. 99–109.
- Duncan, I 2006, 'The changing concept of animal sentience', *Applied Animal Behaviour Science*, vol. 100, no. 1-2, pp. 11–19.
- Dunlop, R, Millsopp, S & Laming, P 2006, 'Avoidance learning in goldfish (*Carassius auratus*) and trout (*Oncorhynchus mykiss*) and implications for pain perception', *Applied Animal Behaviour Science*, vol. 97, no. 2, pp. 255–271.
- Eisenberger, NI, Master, SL, Inagaki, TK, Taylor, SE, Shirinyan, D, Lieberman, MD & Naliboff, BD 2011, 'Attachment figures activate a safety signal-related neural region and reduce pain experience', *Proceedings of the National Academy of Sciences*, vol. 108, no. 28, pp. 11721–11726.
- Elgier, AM, Jakovcevic, A, Barrera, G, Mustaca, AE & Bentosela, M 2009, 'Communication between domestic dogs (*Canis familiaris*) and humans: Dogs are good learners', *Behavioural Processes*, vol. 81, no. 3, pp. 402–408.

- Esliger, DW & Tremblay, MS 2006, 'Technical reliability assessment of three accelerometer models in a mechanical setup', *Medicine and Science in Sports and Exercise*, vol. 38, no. 12, pp. 2173–2181.
- Exnerová, A, Svádová, KH, Fučíková, E, Drent, P & Štys, P 2010, 'Personality matters: individual variation in reactions of naive bird predators to aposematic prey', *Proceedings of the Royal Society B: Biological Sciences*, vol. 277, no. 1682, p. 723.
- Eysenck, MW 1982, *Attention and arousal: Cognition and performance*, Springer, Berlin.
- Eysenck, MW, Mogg, K, May, J, Richards, A & Mathews, A 1991, 'Bias in Interpretation of Ambiguous Sentences Related to Threat in Anxiety', *Journal of Abnormal Psychology*, vol. 100, no. 2, pp. 144–150.
- Faragó, T, Pongrácz, P, Range, F, Virányi, Z & Miklósi, Á 2010, "'The bone is mine": affective and referential aspects of dog growls', *Animal Behaviour*, vol. 79, no. 4, pp. 917–925.
- Farhoody, P & Zink, MC 2010, 'Behavioral and Physical Effects of Spaying and Neutering Domestic Dogs (*Canis familiaris*)', pp. 1–4.
- Fenton, F, Calof, A & Katzev, R 1979, 'The effect of controllable and uncontrollable neonatal preshocks on adult escape/avoidance behavior in the guinea pig (*Cavia porcellus*)', *Animal Learning & Behavior*, no. 7, pp. 372–376.
- Feuerstein, N & Terkel, J 2008, 'Interrelationships of dogs (*Canis familiaris*) and cats (*Felis catus* L.) living under the same roof', *Applied Animal Behaviour Science*, vol. 113, no. 1-3, pp. 150–165.
- Fiset, S & LeBlanc, V 2006, 'Invisible displacement understanding in domestic dogs (*Canis familiaris*): the role of visual cues in search behavior', *Animal Cognition*, vol. 10, no. 2, pp. 211–224.
- Fiset, S, Gagnon, S & Beaulieu, C 2000, 'Spatial encoding of hidden objects in dogs (*Canis familiaris*)', *Journal of Comparative Psychology*, vol. 114, no. 4, pp. 315–324.
- Fiset, S, Landry, F & Ouellette, M 2005, 'Egocentric search for disappearing objects in domestic dogs: evidence for a geometric hypothesis of direction', *Animal Cognition*, vol. 9, no. 1, pp. 1–12.
- Fitch, WT 1997, 'Vocal tract length and formant frequency dispersion correlate with body size in rhesus macaques', *The Journal of the Acoustical Society of America*, vol. 102, no. 2, p. 1213.
- Fokkema, DS & koolhaas, JM 1985, 'Acute and conditioned blood pressure changes in relation to social and psychosocial stimuli in rats.', *Physiology & Behavior*, vol. 34, no. 1, pp. 33–38.

- Fraser, AF 1992, *The Behaviour of the Horse*, C.A.B. International, Oxon.
- Fraser, D 1975, 'The term "stress" in a veterinary context', *The British Veterinary Journal*, vol. 131, pp. 653–662.
- Fratkin, JL, Sinn, DL, Patall, EA & Gosling, SD 2013, 'Personality Consistency in Dogs: A Meta-Analysis', *PloS one*, vol. 8, no. 1, p. e54907.
- Freeman, LM, Rush, JE, Farabaugh, AE & Must, A 2005, 'Development and evaluation of a questionnaire for assessing health-related quality of life in dogs with cardiac disease', *Journal of the American Veterinary Medical Association*, vol. 226, no. 11, pp. 1864–1868.
- Friedman, SG & Brinker, B 2001, 'The struggle for dominance - fact or fiction', *Original Flying Machine*, no. 6, pp. 17–20.
- Fritschi, L 2006, 'Injury in Australian veterinarians', *Occupational Medicine*, vol. 56, no. 3, pp. 199–203.
- Garland, EL, Fredrickson, B, Kring, AM, Johnson, DP, Meyer, PS & Penn, DL 2010, 'Upward spirals of positive emotions counter downward spirals of negativity: Insights from the broaden-and-build theory and affective neuroscience on the treatment of emotion dysfunctions and deficits in psychopathology', *Clinical Psychology Review*, vol. 30, no. 7, pp. 849–864.
- Gaynor, JS & Muir, WW 2009, *Handbook of Veterinary Pain Management* 2nd edn, Mosby Elsevier, St Louis, MO.
- Gácsi, M, Gyoöri, B, Virányi, Z, Kubinyi, E, Range, F, Belényi, B & Miklósi, Á 2009a, 'Explaining Dog Wolf Differences in Utilizing Human Pointing Gestures: Selection for Synergistic Shifts in the Development of Some Social Skills', *PloS one*, vol. 81, no. 8, pp. 383–391.
- Gácsi, M, McGreevy, P, Kara, E & Miklósi, Á 2009b, 'Effects of selection for cooperation and attention in dogs', *Behavioral and Brain Functions*, vol. 5, no. 1, p. 31.
- Goddard, M.E., Beilharz, R.G. 1985. 'Individual variation in agonistic behaviour in dogs'. *Animal Behaviour* 33(4), pp.1338–1342.
- Goddard, M.E. & Beilharz, R.G., 1986. Early prediction of adult behaviour in potential guide dogs. *Applied Animal Behaviour Science*, 15(3), pp.247–260.
- Goldberg, L 1990, 'An Alternative "Description of Personality": The Big-Five Factor Structure', *Journal of Personality and Social Psychology*, vol. 59, no. 6, pp. 1216–1229.
- Goldsmith, HH, Buss, AH, Plomin, R, Rothbart, MK, Thomas, A, Chess, S, Hinde, RA & McCall, R 1987, 'Roundtable: hat is Temperament? Four Approaches', *Child Development Perspectives*, vol. 58, no. 2, pp. 505–529.

- Goodwin, D, Bradshaw, J & Wickens, SM 1997, 'Paedomorphosis affects agonistic visual signals of domestic dogs', *Animal Behaviour*, vol. 53, no. 2, pp. 297–304.
- Gosling, S, Kwan, V & John, O 2003, 'A dog's got personality: A cross-species comparative approach to personality judgments in dogs and humans', *Journal of Personality and Social Psychology*, vol. 85, no. 6, pp. 1161–1169.
- Gosling, SD 2001, 'From mice to men: what can we learn about personality from animal research?', *Psychological Bulletin*, vol. 127, no. 1, pp. 45–86.
- Gosling, SD & John, OP 1999, 'Personality Dimensions in Nonhuman Animals: A Cross-Species Review', *Current Directions in Psychological Science*, vol. 8, no. 3, pp. 69–75.
- Gray, JA 1987, *The psychology of fear and stress*, Cambridge University Press, Cambridge, UK.
- Grzimek, B 1952, 'Versuche uber das Farbsehen von Pflanzenessern', *Zeitschrift fur Tierpsychologie*, vol. 9, no. 1, pp. 23–39.
- Hahn, ME & Wright, JC 1998, 'The influence of genes on social behaviour of dogs', in T Grandin (ed), *Genetics and the behavior of domestic animals*, Academic, New York.
- Hanoch, Y 2004, 'When less is more: Information, Emotional Arousal and the Ecological Reframing of the Yerkes-Dodson Law', *Theory & Psychology*, vol. 14, no. 4, pp. 427–452.
- Hansen, BD, Lascelles, BD, Keene, BW, Adams, AK & Thomson, AE 2007, 'Evaluation of an accelerometer for at-home monitoring of spontaneous activity in dogs', *American Journal of Veterinary Research*, vol. 68, no. 5, pp. 468–475.
- Harcourt, JL, Biau, S, Johnstone, R & Manica, A 2010, 'Boldness and Information Use in Three-Spined Sticklebacks', *Ethology*, vol. 116, no. 5, pp. 440–447.
- Harding, EJ, Paul, ES & Mendl, M 2004, 'Animal behaviour: cognitive bias and affective state', *Nature*, vol. 427, no. 6972, p. 312.
- Haug, LI 2008, 'Canine Aggression Toward Unfamiliar People and Dogs', *Veterinary Clinics of North America: Small Animal Practice*, vol. 38, no. 5, pp. 1023–1041.
- Haverbeke, A, De Smet, A, Depiereux, E, Giffroy, JM & Diederich, C 2009, 'Assessing undesired aggression in military working dogs', *Applied Animal Behaviour Science*, vol. 117, no. 1-2, pp. 55–62.
- Haverbeke, A, Laporte, B, Depiereux, E, Giffroy, JM & Diederich, C 2008, 'Training methods of military dog handlers and their effects on the team's performances', *Applied Animal Behaviour Science*, vol. 113, no. 1-3, pp. 110–

122.

- Haverbeke, A, Rzepa, C, Depiereux, E, Deroo, J, Giffroy, J-M & Diederich, C 2010, 'Assessing efficiency of a Human Familiarisation and Training Programme on fearfulness and aggressiveness of military dogs', *Applied Animal Behaviour Science*, vol. 123, no. 3-4, pp. 143–149.
- Hawson, LA, McLean, AN & McGreevy, PD 2010, 'The roles of equine ethology and applied learning theory in horse-related human injuries', *Journal of Veterinary Behavior: Clinical Applications and Research*, vol. 5, no. 6, pp. 324–338.
- Hebb, DO 1949, *The Organization of Behavior*, Wiley Publishing, Inc., New York, NY.
- Heberlein, M & Turner, DC 2009, 'Dogs, *Canis familiaris*, find hidden food by observing and interacting with a conspecific', *Animal Behaviour*, vol. 78, no. 2, pp. 385–391.
- Heleski, CR, McGreevy, PD, Kaiser, LJ, Lavagnino, M, Tans, E, Bello, N & Clayton, HM 2009, 'Effects on behaviour and rein tension on horses ridden with or without martingales and rein inserts', *The Veterinary Journal*, vol. 181, no. 1, pp. 56–62.
- Helton, WS 2010, 'Does perceived trainability of dog (*Canis lupus familiaris*) breeds reflect differences in learning or differences in physical ability?', *Behavioural Processes*, vol. 83, no. 3, pp. 315–323.
- Helton, WS & Helton, ND 2010, 'Physical size matters in the domestic dog's (*Canis lupus familiaris*) ability to use human pointing cues', *Behavioural Processes*, vol. 85, no. 1, pp. 77–79.
- Hennessy, MB, T Williams, M, Miller, DD, Douglas, CW & Voith, VL 1998, 'Influence of male and female petters on plasma cortisol and behaviour: can human interaction reduce the stress of dogs in a public animal shelter?', *Applied Animal Behaviour Science*, vol. 61, no. 1, pp. 63–77.
- Hennessy, MB, Voith, VL, Mazzei, SJ, Buttram, J, Miller, DD & Linden, F 2001, 'Behavior and cortisol levels of dogs in a public animal shelter, and an exploration of the ability of these measures to predict problem behavior after adoption', *Applied Animal Behaviour Science*, vol. 73, no. 3, pp. 217–233.
- Henry, S, Hemery, D, Richard, MA & Hausberger, M 2005, 'Human–mare relationships and behaviour of foals toward humans', *Applied Animal Behaviour Science*, vol. 93, no. 3-4, pp. 341–362.
- Herrnstein, RJ 1969, 'Method and theory in the study of avoidance.', *Psychological Review*, vol. 76, no. 1, p. 49.
- Herron, ME, Shofer, FS & Reisner, IR 2009, 'Survey of the use and outcome of confrontational and non-confrontational training methods in client-owned

- dogs showing undesired behaviors', *Applied Animal Behaviour Science*, vol. 117, no. 1-2, pp. 47–54.
- Hessing, M.J.C. 1994. Individual behavioural characteristics in pigs and their consequences for pig husbandry. PhD thesis, Department of Animal Husbandry, Agricultural University, Wageningen, The Netherlands. Available at: <http://library.wur.nl/WebQuery/clc/593553>.
- Hickey, C, Chelazzi, L & Theeuwes, J 2010, 'Reward Guides Vision when It's Your Thing: Trait Reward-Seeking in Reward-Mediated Visual Priming' J Harris (ed), *PloS one*, vol. 5, no. 11, p. e14087.
- Hinde, R 1985, 'Was "The expression of the emotions" a misleading phrase?', *Animal Behaviour*, vol. 33, no. 3, pp. 985–992.
- Hoffman, HS & Ratner, AM 1973, 'A reinforcement model of imprinting: Implications for socialization in monkeys and men.', *Psychological Review*, vol. 80, no. 6, p. 527.
- Horowitz, A 2008, 'Attention to attention in domestic dog (*Canis familiaris*) dyadic play', *Animal Cognition*, vol. 12, no. 1, pp. 107–118.
- Horowitz, A 2009, 'Disambiguating the "guilty look": salient prompts to a familiar dog behaviour.', *Behavioural Processes*, vol. 81, no. 3, pp. 447–452.
- Horváth, Z, Dóka, A & Miklosi, A 2008, 'Affiliative and disciplinary behavior of human handlers during play with their dog affects cortisol concentrations in opposite directions', *Hormones and behavior*, vol. 54, no. 1, pp. 107–114.
- Horváth, Z, Igyártó, BZ, Magyar, A & Miklosi, A 2007, 'Three different coping styles in police dogs exposed to a short-term challenge', *Hormones and behavior*, vol. 52, no. 5, pp. 621–630.
- Hsu, Y & Serpell, JA 2003, 'Development and validation of a questionnaire for measuring behavior and temperament traits in pet dogs', *Journal of the American Veterinary Medical Association*, vol. 223, no. 9, pp. 1293–1300.
- Hsu, Y & Sun, L 2010, 'Factors associated with aggressive responses in pet dogs', *Applied Animal Behaviour Science*, vol. 123, no. 3-4, pp. 108–123.
- Hunt, M, Al-Awadi, H & Johnson, M 2008, 'Psychological sequelae of pet loss following Hurricane Katrina', *Anthrozoos: A Multidisciplinary Journal of The Interactions of People & Animals*, vol. 21, no. 2, pp. 109–121.
- Jing, J, Gillette, R & Weiss, KR 2009, 'Evolving concepts of arousal: insights from simple model systems', *Rev Neurosci*, vol. 20, pp. 405–427.
- John, OP, Robins, RW & Pervin, LA 2008, *Handbook of Personality: Theory and Research* 3rd edn, The Guildford Press, New York.
- Jones, AC & Gosling, SD 2005, 'Temperament and personality in dogs (*Canis*

- familiaris*): A review and evaluation of past research', *Applied Animal Behaviour Science*, vol. 95, no. 1-2, pp. 1–53.
- Jones, AC & Josephs, RA 2006, 'Interspecies hormonal interactions between man and the domestic dog (*Canis familiaris*)', *Hormones and behavior*, vol. 50, no. 3, pp. 393–400.
- Jones, B & McGreevy, PD 2010, 'Ethical equitation: Applying a cost-benefit approach', *Journal of Veterinary Behavior: Clinical Applications and Research*, vol. 5, no. 4, pp. 196–202.
- Jones, BE 2003, 'Arousal systems', *Frontiers in Bioscience*, vol. 8, pp. s438–s451.
- Jones, K.A. & Godin, J., 2009. 'Are fast explorers slow reactors? Linking personality type and anti-predator behaviour'. *Proceedings of the Royal Society B: Biological Sciences*, vol. 277, pp.625–632.
- Kalén, P., Rosegren, E., Lindvall, O., Björklund, A., 1989. 'Hippocampal Noradrenaline and Serotonin Release over 24 Hours as Measured by the Dialysis Technique in Freely Moving Rats: Correlation to Behavioural Activity State, Effect of Handling and Tail-Pinch'. *European Journal of Neuroscience* vol. 1, no. 3, pp.181–188.
- Katzner, S., Miller, J. 2012. 'Response-level probability effects on reaction time: Now you see them, now you don't'. *Quarterly Journal of Experimental Psychology*, vol. 65, no. 5, pp.865–886.
- Kavussanu, M & McAuley, E 1995, 'Exercise and optimism: Are highly active individuals more optimistic?', *Journal of Sport and Exercise Psychology*, vol. 17, pp. 246–246.
- Kerepesi, A, Jonsson, GK, Miklosi, A, Topal, J, Csanyi, V & Magnusson, MS 2005, 'Detection of temporal patterns in dog–human interaction', *Behavioural Processes*, vol. 70, no. 1, pp. 69–79.
- Kern, KV 1987BC, *The new terrier handbook*, Barron's Educational Series Inc., New York.
- Kilgour, R 1978, 'The Application of Animal Behavior and the Humane Care of Farm Animals', *Journal of animal science*, vol. 46, pp. 1478–1486.
- Kim, H.H. et al., 2006. Effects of ovariohysterectomy on reactivity in German Shepherd dogs. *The Veterinary Journal*, 172(1), pp.154–159.
- King, JE, Weiss, Alexander & Farmer, KH 2005, 'A Chimpanzee (*Pan troglodytes*) Analogue of Cross-National Generalization of Personality Structure: Zoological Parks and an African Sanctuary', *Journal of Personality*, vol. 73, no. 2, pp. 389–410.
- King, T, Marston, LC & Bennett, PC 2009, 'Describing the ideal Australian companion dog', *Applied Animal Behaviour Science*, vol. 120, no. 1-2, pp. 84–

- Klein, E & Uhde, TW 1988, '24-Hour motor activity in genetically nervous and normal pointer dogs', *Biological Psychiatry*, vol. 23, no. 5, pp. 523–527.
- Kolevská, J., Brunclik, V., Svoboda, M. 2003. 'Circadian rhythm of cortisol secretion in dogs of different daily activities'. *Acta Veterinaria Brno*, vol. 72, no. 4, pp.599
- Konok, V, Dóka, A & Miklósi, Á 2011, 'The behavior of the domestic dog (*Canis familiaris*) during separation from and reunion with the owner: A questionnaire and an experimental study', *Applied Animal Behaviour Science*, vol. 135, no. 4, pp. 300–308.
- Kotrschal, K., Schöberl, I., Bauer, B., Thibeaut, A., Wedl, M., 2009. 'Dyadic relationships and operational performance of male and female owners and their male dogs'. *Behavioural Processes*, vol. 81, pp.383-391.
- Koolhaas, JM 2008, 'Coping style and immunity in animals: making sense of individual variation', *Brain, Behavior, and Immunity*, vol. 22, no. 5, pp. 662–667.
- Koolhaas, JM, De Boer, SF, Coppens, CM & Buwalda, B 2010, 'Neuroendocrinology of coping styles: Towards understanding the biology of individual variation', *Frontiers in Neuroendocrinology*, vol. 31, no. 3, pp. 307–321.
- Koolhaas, JM, Korte, SM, De Boer, SF, Van Der Vegt, BJ, Van Reenen, CG, Hopster, H, de Jong, IC, Ruis, M & Blokhuis, HJ 1999, 'Coping styles in animals: current status in behavior and stress-physiology', *Neuroscience & Biobehavioral Reviews*, vol. 23, no. 7, pp. 925–935.
- Korte, S, Beuving, G, Ruesink, W & Blokhuis, HJ 1997, 'Plasma Catecholamine and Corticosterone Levels During Manual Restraint in Chicks from a High and Low Feather Pecking Line of Laying Hens', *Physiology & Behavior*, vol. 62, no. 3, pp. 437–441.
- Korte, SM, Meijer, OC, de Kloet, ER, Buwalda, B, Keijser, J, Sluyter, F, van Oortmerssen, G & Bohus, B 1996, 'Enhanced 5-HT_{1A} receptor expression in forebrain regions of aggressive house mice', *Brain Research*, vol. 736, no. 1-2, pp. 338–343.
- Korte, SM, Olivier, B & koolhaas, JM 2007, 'A new animal welfare concept based on allostasis', *Physiology & Behavior*, vol. 92, no. 3, pp. 422–428.
- Korte, SM, Ruesink, W & Blokhuis, HJ 1999, 'Heart rate variability during manual restraint in chicks from high- and low-feather pecking lines of laying hens.', *Physiology & Behavior*, vol. 65, no. 4-5, pp. 649–652.
- Koskinen, MT 2003, 'Individual assignment using microsatellite DNA reveals unambiguous breed identification in the domestic dog', *Animal Genetics*, vol. 34, no. 4, pp. 297–301.

- Kraut, RE & Johnston, RE 1979, 'Social and emotional messages of smiling: An ethological approach', *Journal of Personality and Social Psychology*, vol. 37, no. 9, pp. 1539–1553.
- Krueger, RF, Hicks, BM & McGue, M 2001, 'Altruism and antisocial behavior: independent tendencies, unique personality correlates, distinct etiologies.', *Psychological Science*, vol. 12, no. 5, pp. 397–402.
- Kubinyi, E, Turcsán, B & Miklosi, A 2009, 'Dog and owner demographic characteristics and dog personality trait associations', *Behavioural Processes*, vol. 81, no. 3, pp. 392–401.
- Lampe, JF & Andre, J 2012, 'Cross-modal recognition of human individuals in domestic horses (*Equus caballus*)', *Animal Cognition*, vol. 15, no. 4, pp. 623–630.
- Landercasper, J, Cogbill, TH, Strutt, PJ & Landercasper, BO 1988, 'Trauma and the Veterinarian', *The Journal of Trauma: Injury, Infection, and Critical Care*, vol. 28, no. 8, pp. 1255–1259.
- Le-Masurier, GC & Tudor-Locke, C 2003, 'Comparison of pedometer and accelerometer accuracy under controlled conditions', *Medicine and Science in Sports and Exercise*, vol. 35, no. 5, pp. 867–871.
- Lefebvre, D, Diederich, C, Delcourt, M & Giffroy, J-M 2007, 'The quality of the relation between handler and military dogs influences efficiency and welfare of dogs', *Applied Animal Behaviour Science*, vol. 104, no. 1-2, pp. 49–60.
- Lethbridge, E 2009, *Knowing Your Horse - A guide to Equine Learning, Training and Behaviour*, Wiley-Blackwell, Chichester, UK.
- Ley, J, Bennett, P & Coleman, G 2008, 'Personality dimensions that emerge in companion canines', *Applied Animal Behaviour Science*, vol. 110, no. 3-4, pp. 305–317.
- Ley, J, McGreevy, P & Bennett, P 2009, 'Inter-rater and test-retest reliability of the Monash Canine Personality Questionnaire-Revised (MCPQ-R)', *Applied Animal Behaviour Science*, vol. 119, pp. 85–90.
- Li, SSY & McNally, GP 2013, 'Accepted Manuscript', *Neurobiology of Learning and Memory*, pp. 1–31.
- Ligout, S 2010, 'Social Learning', in D Mills, J Marchant-Forde, PD McGreevy, DB Morton, CJ Nicol, C Phillips, P Sandoe, & RR Swaisgood (eds), *Encyclopedia of Applied Animal Behaviour and Welfare*, CABI Publishing, Wallingford, Oxon, p. 563.
- Lindblad-Toh, K, Wade, CM, Mikkelsen, TS, Karlsson, EK, Jaffe, DB, Kamal, M, Clamp, M, Chang, JL, Kulbokas, EJ, Zody, MC, Mauceli, E, Xie, X, Breen, M, Wayne, RK, Ostrander, EA, Ponting, CP, Galibert, F, Smith, DR, deJong, PJ, Kirkness, E, Alvarez, P, Biagi, T, Brockman, W, Butler, J, Chin, C-W, Cook, A,

Cuff, J, Daly, MJ, DeCaprio, D, Gnerre, S, Grabherr, M, Kellis, M, Kleber, M, Bardeleben, C, Goodstadt, L, Heger, A, Hitte, C, Kim, L, Koepfli, K-P, Parker, HG, Pollinger, JP, Searle, SMJ, Sutter, NB, Thomas, R, Webber, C, Baldwin, J, Abebe, A, Abouelleil, A, Aftuck, L, Ait-zahra, M, Aldredge, T, Allen, N, An, P, Anderson, S, Antoine, C, Arachchi, H, Aslam, A, Ayotte, L, Bachantsang, P, Barry, A, Bayul, T, Benamara, M, Berlin, A, Bessette, D, Blitshteyn, B, Bloom, T, Blye, J, Boguslavskiy, L, Bonnet, C, Boukhgalter, B, Brown, A, Cahill, P, Calixte, N, Camarata, J, Cheshatsang, Y, Chu, J, Citroen, M, Collymore, A, Cooke, P, Dawoe, T, Daza, R, Decktor, K, DeGray, S, Dhargay, N, Dooley, K, Dooley, K, Dorje, P, Dorjee, K, Dorris, L, Duffey, N, Dupes, A, Egbiremolen, O, Elong, R, Falk, J, Farina, A, Faro, S, Ferguson, D, Ferreira, P, Fisher, S, FitzGerald, M, Foley, K, Foley, C, Franke, A, Friedrich, D, Gage, D, Garber, M, Gearin, G, Giannoukos, G, Goode, T, Goyette, A, Graham, J, Grandbois, E, Gyaltzen, K, Hafez, N, Hagopian, D, Hagos, B, Hall, J, Healy, C, Hegarty, R, Honan, T, Horn, A, Houde, N, Hughes, L, Hunnicutt, L, Husby, M, Jester, B, Jones, C, Kamat, A, Kanga, B, Kells, C, Khazanovich, D, Kieu, AC, Kisner, P, Kumar, M, Lance, K, Landers, T, Lara, M, Lee, W, Leger, J-P, Lennon, N, Leuper, L, LeVine, S, Liu, J, Liu, X, Lokyitsang, Y, Lokyitsang, T, Lui, A, Macdonald, J, Major, J, Marabella, R, Maru, K, Matthews, C, McDonough, S, Mehta, T, Meldrim, J, Melnikov, A, Meneus, L, Mihalev, A, Mihova, T, Miller, K, Mittelman, R, Mlenga, V, Mulrain, L, Munson, G, Navidi, A, Naylor, J, Nguyen, T, Nguyen, N, Nguyen, C, Nguyen, T, Nicol, R, Norbu, N, Norbu, C, Novod, N, Nyima, T, Olandt, P, O apos Neill, B, O apos Neill, K, Osman, S, Oyono, L, Patti, C, Perrin, D, Phunkhang, P, Pierre, F, Priest, M, Rachupka, A, Raghuraman, S, Rameau, R, Ray, V, Raymond, C, Rege, F, Rise, C, Rogers, J, Rogov, P, Sahalie, J, Settipalli, S, Sharpe, T, Shea, T, Sheehan, M, Sherpa, N, Shi, J, Shih, D, Sloan, J, Smith, C, Sparrow, T, Stalker, J, Stange-Thomann, N, Stavropoulos, S, Stone, C, Stone, S, Sykes, S, Tchuinga, P, Tenzing, P, Tesfaye, S, Thoulutsang, D, Thoulutsang, Y, Topham, K, Topping, I, Tsamla, T, Vassiliev, H, Venkataraman, V, Vo, A, Wangchuk, T, Wangdi, T, Weiland, M, Wilkinson, J, Wilson, A, Yadav, S, Yang, S, Yang, X, Young, G, Yu, Q, Zainoun, J, Zembek, L, Zimmer, A & Lander, ES 2005, 'Genome sequence, comparative analysis and haplotype structure of the domestic dog', *Nature*, vol. 438, no. 7069, pp. 803–819.

Lindström, L 2010, 'Performance of laying hens in a cognitive bias task'. Thesis, available: http://stud.epsilon.slu.se/863/3/lindstrom_l_100312.pdf.

Lit, L, Schweitzer, JB, Iosif, AM & Oberbauer, AM 2010, 'Owner reports of attention, activity, and impulsivity in dogs: a replication study', *Behavioral and Brain Functions*, vol. 6, no. 1, p. 1.

Lovibond, PF, Chen, SX, Mitchell, CJ & Weidemann, G 2013, 'Competition between an avoidance response and a safety signal: evidence for a single learning system.', *Biological Psychology*, vol. 92, no. 1, pp. 9–16.

Mack, A 2003, 'Inattentive blindness: looking without seeing', *Current Directions in Psychological Science*, vol. 12, no. 5, pp. 180–184.

MacLeod, AK & Byrne, A 1996, 'Anxiety, Depression, and the Anticipation of Future Positive and Negative Experiences', *Journal of Abnormal Psychology*,

- vol. 105, no. 2, pp. 286–289.
- Maestriperi, D., Schino, G. Aureli, F., Troisi, A., 1992. 'A modest proposal: displacement activities as an indicator of emotions in primates'. *Animal Behaviour*, vol. 44, no. 5, pp.967–979.
- Mair, RG, Onos, KD & Hembrook, JR 2011, 'Cognitive Activation by Central Thalamic Stimulation: The Yerkes-Dodson Law Revisited', *Dose-Response*, vol. 9, no. 3, pp. 313–331.
- Marler, P & Evans, C 1996, 'Bird calls: just emotional displays or something more?', *Ibis*, vol. 138, no. 4, pp. 26–33.
- Marshall-Pescini, S, Passalacqua, C, Barnard, S, Valsecchi, P & Prato-Previde, E 2009, 'Agility and search and rescue training differently affects pet dogs' behaviour in socio-cognitive tasks', *Behavioural Processes*, vol. 81, no. 3, pp. 416–422.
- Marston, LC, Bennett, PC & Coleman, GJ 2004, 'What Happens to Shelter Dogs? An Analysis of Data for 1 Year From Three Australian Shelters', *Journal of Applied Animal Welfare Science*, vol. 7, no. 1, pp. 27–47.
- Masters, AM & McGreevy, PD 2008, 'Dogkeeping practices as reported by readers of an Australian dog enthusiast magazine', *Australian veterinary journal*, vol. 86, no. 1-2, pp. 18–25.
- Matheson, S, Asher, L & Bateson, M 2008, 'Larger, enriched cages are associated with "optimistic" response biases in captive European starlings (*Sturnus vulgaris*)', *Applied Animal Behaviour Science*, vol. 109, no. 2-4, pp. 374–383.
- Mathews, A & MacLeod, C 1985, 'Selective processing of threat cues in anxiety states', *Behaviour Research and Therapy*, vol. 23, no. 5, pp. 563–569.
- McAfee, LM, Mills, DS & Cooper, JJ 2002, 'The use of mirrors for the control of stereotypic weaving behaviour in the stabled horse', *Applied Animal Behaviour Science*, vol. 78, no. 2-4, pp. 159–173.
- McAllister, WR & McAllister, DE 1992, 'Fear determines the effectiveness of a feedback stimulus in aversively motivated instrumental learning', *Learning and Motivation*, vol. 23, no. 1, pp. 99–115.
- McConnell, PB 2002, *The other end of the leash: why we do what we do around dogs*, Bantam, Milsons Point, NSW.
- McCrae, RR, Costa, PT, Pedroso de Lima, M, Simões, A, Ostendorf, F, Angleitner, A, Marusić, I, Bratko, D, Caprara, GV, Barbaranelli, C, Chae, JH & Piedmont, RL 1999, 'Age differences in personality across the adult life span: parallels in five cultures.', *Developmental psychology*, vol. 35, no. 2, pp. 466–477.
- McCrae, R.R., 2000. 'Trait psychology and the revival of personality and culture studies'. *American Behavioral Scientist* , vol. 44, no. 1, pp.10–31.

- McDevitt, L 2007, *Control Unleashed*, Clean Run Productions LLC, South Hadley, MA.
- McGreevy, P & Boakes, RA 2007, *Carrots and sticks: Principles of animal training*, Cambridge University Press, Cambridge.
- McGreevy, P. & Masters, A., 2008. Risk factors for separation-related distress and feed-related aggression in dogs: Additional findings from a survey of Australian dog owners. *Applied Animal Behaviour Science*, vol. 109, no. 2-4, pp.320-328.
- McGreevy, P., Grassi, T.D. & Harman, A.M., 2004. 'A Strong Correlation Exists between the Distribution of Retinal Ganglion Cells and Nose Length in the Dog'. *Brain, Behavior and Evolution*, vol. 63, no. 1, pp.13-22.
- McGreevy, P, Oddie, C, Burton, F & McLean, A 2009a, 'The horse-human dyad: Can we align horse training and handling activities with the equid social ethogram', *The Veterinary Journal*, vol. 181, no. 1.
- McGreevy, PD 2009, *A Modern Dog's Life*, UNSW Press, Randwick, NSW.
- McGreevy, PD 2007a, 'Breeding for quality of life', *ANIMAL WELFARE-POTTERS BAR-*, vol. 16, no. Supplement 1, pp. 125-128.
- McGreevy, PD 2004, *Equine behaviour - a guide for veterinarians and equine scientists*, W.B. Saunders, London.
- McGreevy, PD 2007b, 'The advent of equitation science', *The Veterinary Journal*, vol. 174, no. 3, pp. 492-500.
- McGreevy, PD & Bennett, PC 2010, 'Challenges and paradoxes in the companion-animal niche', *ANIMAL WELFARE-POTTERS BAR-*, vol. 19, no. Supplement 1, pp. 11-16.
- McGreevy, PD & Calnon, D 2010, 'Getting canine aggression in perspective', *The Veterinary Journal*, vol. 186, no. 1, pp. 1-2.
- McGreevy, PD & McLean, A 2010, *Equitation Science*, Wiley Blackwell, Oxon.
- McGreevy, PD & Nicholas, FW 1999, 'Some practical solutions to welfare problems in dog breeding', *ANIMAL WELFARE-POTTERS BAR-*, vol. 8, pp. 329-342.
- McGreevy, PD, McLean, AN, Keay, KA & Thomson, PC 2009b, 'SMART: Sensitivity models for animals in response to training', *The Veterinary Journal*, vol. 181, no. 1, pp. 72-73.
- McGreevy, PD, Righetti, J & Thomson, PC 2005, 'The reinforcing value of physical contact and the effect on canine heart rate of grooming in different anatomical areas', *Anthrozoos: A Multidisciplinary Journal of The Interactions of People 38; Animals*, vol. 18, no. 3, pp. 236-244.

- McGreevy, PD, Starling, M, Branson, NJ, Cobb, ML & Calnon, D 2012, 'An overview of the dog-human dyad and ethograms within it', *Journal of Veterinary Behavior: Clinical Applications and Research*, vol. 7, no. 2, pp. 103–117.
- McGreevy, PD, Thomson, PC, Pride, C, Fawcett, A, Grassi, T & Jones, B 2005, 'Prevalence of obesity in dogs examined by Australian veterinary practices and the risk factors involved.', *The Veterinary Record*, vol. 156, no. 22, pp. 695–702.
- McKinley, S & Young, RJ 2003, 'The efficacy of the model–rival method when compared with operant conditioning for training domestic dogs to perform a retrieval–selection task', *Applied Animal Behaviour Science*, vol. 81, no. 4, pp. 357–365.
- McLean, A 2003, *The Truth About Horses*, Quarto Publishing, London.
- McLean, AN & McGreevy, PD 2010, 'Horse-training techniques that may defy the principles of learning theory and compromise welfare', *Journal of Veterinary Behavior: Clinical Applications and Research*, vol. 5, no. 4, pp. 187–195.
- Mech, LD 1999, 'Alpha status, dominance, and division of labor in wolf packs', *Canadian Journal of Zoology*, vol. 77, no. 8, pp. 1196–1203.
- Mendl, M., Burman, O.H.P., Parker, R.M.A., Paul, E.S., 2009. 'Cognitive bias as an indicator of animal emotion and welfare: Emerging evidence and underlying mechanisms'. *Applied Animal Behaviour Science*, vol. 118, no. 3-4, pp.161–181.
- Mendl, M., Brooks, J., Basse, C., Burman, O., Paul, E., Blackwell, E. & Casey, R., 2010a. 'Dogs showing separation-related behaviour exhibit a “pessimistic” cognitive bias'. *Current Biology*, vol. 20, no. 19.
- Mendl, M., Burman, O.H.P. & Paul, E.S., 2010c. 'An integrative and functional framework for the study of animal emotion and mood'. *Proceedings of the Royal Society B: Biological Sciences*, vol. 277, no. 1696, pp.2895–2904.
- Meuten, D.J., 2002. *Tumors in Domestic Animals* 4 ed, Ames, Iowa: Iowa State Press, Blackwell Publishing Company.
- Michel, K.E. & Brown, D.C., 2011. 'Determination and application of cut points for accelerometer-based activity counts of activities with differing intensity in pet dogs'. *American Journal of Veterinary Research*, vol. 72, no. 7, pp.866–870.
- Michelena, P., Jeanson, R. & Deneubourg, J., 2009. 'Personality and collective decision-making in foraging herbivores'. *Proceedings of the Royal Society B: Biological Sciences*, vol. 277, pp.1093–1099.
- Miklosi, A., Topal, J. & Csanyi, V., 2004. 'Comparative social cognition: what can dogs teach us?' *Animal Behaviour*, vol. 67, no. 6, pp.995–1004.
- Miklósi, Á, Kubinyi, E, Topál, J, Gácsi, M, Virányi, Z & Csányi, V 2003, 'A Simple

- Reason for a Big Difference', *Current Biology*, vol. 13, no. 9, pp. 763–766.
- Miklósi, Á, Topál, J & Csányi, V 2007, 'Big thoughts in small brains? Dogs as a model for understanding human social cognition', *Neuroreport*, vol. 18, no. 5, pp. 467–471.
- Millan, C. 2006. *Cesar's Way*, Great Britain: Hodder and Stroughton.
- Miller, HC, DeWall, CN, Pattison, K, Molet, M & Zentall, TR 2012, 'Too dog tired to avoid danger: Self-control depletion in canines increases behavioral approach toward an aggressive threat', *Psychonomic Bulletin & Review*, vol. 19, no. 3, pp. 535–540.
- Miller, HC, Pattison, KF, DeWall, CN, Rayburn-Reeves, R & Zentall, TR 2010, 'Self-Control Without a "Self": Common Self-Control Processes in Humans and Dogs', *Psychological Science*, vol. 21, no. 4, pp. 534–538.
- Miller, R & Lamb, R 2005, *The Revolution in Horsemanship and What it Means to Mankind*, Lyons Press, Guildford, CT.
- Mills, DS & Riezebos, M 2005, 'The role of the image of a conspecific in the regulation of stereotypic head movements in the horse', *Applied Animal Behaviour Science*, vol. 91, no. 1-2, pp. 155–165.
- Mineka, S 1979, 'The role of fear in theories of avoidance learning, flooding, and extinction.', *Psychological Bulletin*, vol. 86, no. 5, pp. 985–1010.
- Miranda, R., Mennin, D.S., 2007a 'Depression, Generalized Anxiety Disorder, and Certainty in Pessimistic Predictions about the Future'. *Cognitive Therapy and Research*, vol. 31, no. 1, pp.71–82.
- Misra, RP 1995, *Environmental Ethics: A Dialogue of Cultures*, Concept Publishing Company, New Delhi.
- Moberg, GP & Mench, JA 2000, *The Biology of Animal Stress: Basic Principles and Implications for Animal Welfare*, CABI Publishing, Wallingford, UK.
- Moehlman, PD 1987, 'Social Organization in Jackals: The complex social system of jackals allows the successful rearing of very dependent young', *American Scientist*, vol. 75, no. 4, pp. 366–375.
- Mornement, KM, Coleman, GJ, Toukhsati, S & Bennett, PC 2010, 'A Review of Behavioral Assessment Protocols Used by Australian Animal Shelters to Determine the Adoption Suitability of Dogs', *Journal of Applied Animal Welfare Science*, vol. 13, no. 4, pp. 314–329.
- Morris, D 2001, *Dogs: a dictionary of dog breeds*, Ebury, London.
- Morris, RGM 1974, 'Pavlovian conditioned inhibition of fear during shuttlebox avoidance behavior', *Learning and Motivation*, vol. 5, no. 4, pp. 424–447.

- Moruzzi, G 1969, 'Sleep and Instinctive Behaviour', *Archives Italiennes de Biologie*, pp. 175–216.
- Mowrer, O.H., 1939. 'A stimulus-response analysis of anxiety and its role as a reinforcing agent'. *Psychological Review*, vol. 46, no. 6, p.553.
- Mowrer, O.H., 1960. *Learning theory and the symbolic processes*, New York: Wiley.
- Mowrer, O.H. & Lamoreaux, R.R., 1946. 'Fear as an intervening variable in avoidance conditioning'. *Journal of Comparative Psychology*, vol. 39, pp.29–50.
- Mowrer, O.H. & Lamoreaux, R.R., 1942. 'Avoidance conditioning and signal duration- a study of secondary motivation and reward'. *Psychological Monographs*, vol. 54, no. 5.
- Müller, CA, Riemer, S, Rosam, CM, Schößwender, J, Range, F & Huber, L 2012, 'Brief owner absence does not induce negative judgement bias in pet dogs', *Animal Cognition*, vol. 15, no. 5, pp. 1031–1035.
- Müller-Schwarze, D., 1991. 'The chemical ecology of ungulates'. *Applied Animal Behaviour Science*, vol. 29, no. 1-4, pp.389–402.
- Neilson, JC, Hart, BL, Cliff, KD & Ruehl, WW 2001, 'Prevalence of behavioral changes associated with age-related cognitive impairment in dogs.', *Journal of the American Veterinary Medical Association*, vol. 218, no. 11, pp. 1787–1791.
- Nes, L.S. & Segerstrom, S.C., 2006. 'Dispositional Optimism and Coping: A Meta-Analytic Review'. *Personality and Social Psychology Review*, vol. 10, no. 3, pp.235–251.
- Netto, W.J., Planta, D.J.U., 1997. 'Behavioural testing for aggression in the domestic dog'. *Applied Animal Behaviour Science* vol. 52, no. 3-4, pp.243–263.
- Nguyen-Michel, ST, Baranowski, T, Unger, JB, Klesges, LM, Hamilton, J, Ey, S, Spruijt-Metz, D, Pratt, C, Rochon, J & Zhou, A 2006, 'Associations between physical activity and perceived stress/hassles in college students', *Stress and Health*, vol. 22, no. 3, pp. 179–188.
- Nicol, CJ & Pope, SJ 1999, 'The effects of demonstrator social status and prior foraging success on social learning in laying hens', *Animal Behaviour*, vol. 57, no. 1, pp. 163–171.
- Nijhout, H. F., 2003. 'The importance of context in genetics'. *Science*, vol. 91, no. 5, pp.416–423.
- Nuttall, T & McEwan, N 2006, 'Objective measurement of pruritus in dogs: a preliminary study using activity monitors', *Veterinary Dermatology*, vol. 17, no. 5, pp. 348–351.

- Odendaal, J.S.J. & Meintjes, R.A., 2003. 'Neurophysiological Correlates of Affiliative Behaviour between Humans and Dogs'. *The Veterinary Journal*, vol. 165, no. 3, pp.296–301.
- Ohl, F, Arndt, SS & van der Staay, FJ 2008, 'Pathological anxiety in animals', *The Veterinary Journal*, vol. 175, no. 1, pp. 18–26.
- Oliver, M, Badland, HM, Shepherd, J & Schofield, GM 2011, 'Counting steps in research: A comparison of accelerometry and pedometry', *Open Journal of Preventative Medicine*, vol. 1, pp. 1–7.
- Overall, KL 2004, 'Medical differentials with potential behavioral manifestations', *Clinical techniques in small animal practice*, vol. 19, no. 4, pp. 250–258.
- Overall, K.L., 2005. 'Proceedings of the Dogs Trust Meeting on Advances in Veterinary Behavioural Medicine London; 4th–7th November 2004'. *The Veterinary Journal*, vol. 169, no. 1, pp.130–143.
- Overmier, JB & Seligman, ME 1967, 'Effects of inescapable shock upon subsequent escape and avoidance responding.', *Journal of Comparative and Physiological Psychology*, vol. 63, no. 1, p. 28.
- Ozanne-Smith, J, Ashby, K & Stathakis, V 1998, 'Dog bites and injury prevention: A critical review and research agenda '.
- Ozanne-Smith, J, Ashby, K & Stathakis, VZ 2001, 'Dog bite and injury prevention--analysis, critical review, and research agenda.', *Injury prevention : journal of the International Society for Child and Adolescent Injury Prevention*, vol. 7, no. 4, pp. 321–326.
- Pal, SK, Ghosh, B & Roy, S 1998, 'Agonistic behaviour of free-ranging dogs (*Canis familiaris*) in relation to season, sex and age', *Applied Animal Behaviour Science*, vol. 59, no. 4, pp. 331–348.
- Palika, L 2007, *Howell book of dogs*, Wiley Publishing, Inc., Hoboken, New Jersey.
- Palomo, T, Beninger, RJ, Kostrzewa, RM & Archer, T 2008, 'Affective status in relation to impulsive, motor and motivational symptoms: Personality, development and physical exercise', *Neurotoxicity Research*, vol. 14, no. 2-3, pp. 151–168.
- Panksepp, J 1998, *Affective Neuroscience The Foundations of Human and Animal Emotions*, Oxford University Press, New York.
- Parelli, P *Natural Horsemanship*, Western Horeseman, Fort Worth, TX.
- Parker, GA 1974, 'Assessment strategy and the evolution of fighting behaviour.', *Journal of theoretical biology*, vol. 47, no. 1, pp. 223–243
- Parker, HG, Kukekova, AV, Akey, DT, Goldstein, O, Kirkness, EF, Baysac, KC, Mosher, DS, Aguirre, GD, Acland, GM & Ostrander, EA 2007, 'Breed

- relationships facilitate fine-mapping studies: A 7.8-kb deletion cosegregates with Collie eye anomaly across multiple dog breeds', *Genome Research*, vol. 17, no. 11, pp. 1562–1571.
- Paul, D, Kramer, M, Moshfegh, A, Baer, D & Rumpler, W 2007, 'Comparison of two different physical activity monitors', *BMC Medical Research Methodology*, vol. 7, no. 1, p. 26.
- Paul, E, Harding, E & Mendl, M 2005, 'Measuring emotional processes in animals: the utility of a cognitive approach', *Neuroscience & Biobehavioral Reviews*, vol. 29, no. 3, pp. 469–491.
- Petherick, JC 2010, 'Dominance', in D Mills, J Marchant-Forde, PD McGreevy, DB Morton, CJ Nicol, CJC Phillips, P Sandoe, & RR Swaisgood (eds), *Encyclopedia of Applied Animal Behaviour and Welfare*, CABI Publishing, Wallingford, Oxon, pp. 185–186.
- Pfaff, D, Ribeiro, A, Matthews, J & Kow, L-M 2008, 'Concepts and Mechanisms of Generalized Central Nervous System Arousal', *Annals of the New York Academy of Sciences*, vol. 1129, no. 1, pp. 11–25.
- Plant, JD 2008, 'Correlation of observed nocturnal pruritus and actigraphy in dogs.', *The Veterinary Record*, vol. 162, no. 19, pp. 624–625.
- Plowman, JC 'Ethogram', in *Encyclopedia of Applied Animal Behaviour and Welfare*, CABI Publishing, Wallingford, Oxon, pp. 228–230.
- Pollak, DD, Monje, FJ, Zuckerman, L, Denny, CA, Drew, MR & Kandel, ER 2008, 'An animal model of a behavioral intervention for depression.', *Neuron*, vol. 60, no. 1, pp. 149–161.
- Pongrácz, P, Molnár, C & Miklósi, Á 2006, 'Acoustic parameters of dog barks carry emotional information for humans', *Applied Animal Behaviour Science*, vol. 100, no. 3-4, pp. 228–240.
- Pongrácz, P, Molnár, C, Miklósi, Á & Csányi, V 2005, 'Human Listeners Are Able to Classify Dog (*Canis familiaris*) Barks Recorded in Different Situations.', *Journal of Comparative Psychology*, vol. 119, no. 2, pp. 136–144.
- Pongrácz, P, Vida, V, Bánhegyi, P & Miklósi, Á 2008, 'How does dominance rank status affect individual and social learning performance in the dog (*Canis familiaris*)?', *Animal Cognition*, vol. 11, no. 1, pp. 75–82.
- Powell, RW & Peck, S 1969, 'Running-wheel activity and avoidance in the mongolian gerbil.', *Journal of the experimental analysis of behavior*, vol. 12, no. 5, pp. 779–787.
- Pratto, F, Sidanius, J, Stallworth, LM & Malle, BF 1994, 'Social dominance orientation: A personality variable predicting social and political attitudes.', *Journal of Personality and Social Psychology; Journal of Personality and Social Psychology*, vol. 67, no. 4, pp. 741–763.

- Proops, L & McComb, K 2012, 'Cross-modal individual recognition in domestic horses (*Equus caballus*) extends to familiar humans', *Proceedings of the Royal Society B: Biological Sciences*, vol. 279, pp. 3131–3138.
- Randall, D & Burggren, W 2001, *Eckert Animal Physiology: Mechanisms and Adaptations*, W.H. Freeman & Co Ltd., London.
- Range, F, Heucke, SL, Gruber, C, Konz, A, Huber, L & Virányi, Z 2009, 'The effect of ostensive cues on dogs' performance in a manipulative social learning task', *Applied Animal Behaviour Science*, vol. 120, no. 3-4, pp. 170–178.
- Reefmann, N, Wechsler, B & Gygas, L 2009, 'Behavioural and physiological assessment of positive and negative emotion in sheep', *Animal Behaviour*, vol. 78, no. 3, pp. 651–659.
- Rescorla, RA & Solomon, R 1967, 'Two-process learning theory: Relationships between Pavlovian conditioning and instrumental learning', *Psychological Review*, vol. 74, no. 3, pp. 151–182.
- Ritvo, H 1990, *The Animal Estate*, Penguin Books.
- Robbins, TW 1997, 'Arousal systems and attentional processes', *Biological Psychology*, vol. 45, no. 1, pp. 57–71.
- Roberts, M 1997, *The Man who Listens to Horses*, Arrow Books, London, UK.
- Rogerson, J 2008, *Your Dog: Its Development, Behaviour and Training*, Popular Dogs Publishing, London.
- Rooney, N, Bradshaw, J & Robinson, I 2000, 'A comparison of dog-dog and dog-human play behaviour', *Applied Animal Behaviour Science*, vol. 66, no. 3, pp. 235–248.
- Rooney, N.J., Gaines, S.A., Bradshaw, J.W.S., Penman, S. 2007., Validation of a method for assessing the ability of trainee specialist search dogs. *Applied Animal Behaviour Science* 103(1-2), pp.90–104.
- Rooney, NJ & Cowan, S 2011, 'Training methods and owner-dog interactions: Links with dog behaviour and learning ability', *Applied Animal Behaviour Science*, vol. 132, no. 3-4, pp. 169–177.
- Rowell, CH 1961, 'Displacement grooming in the chaffinch', *Animal Behaviour*, vol. 9, no. 1, pp. 38–63.
- Ruis, MAW, Brake, te, JHA, van de Burgwal, JA, de Jong, IC, Blokhuis, HJ & Koolhaas, JM 2000, 'Personalities in female domesticated pigs: behavioural and physiological indications', *Applied Animal Behaviour Science*, vol. 66, no. 1-2, pp. 31–47.
- Russell, JA & Bullock, M 1985, 'Multidimensional scaling of emotional facial expressions: Similarity from preschoolers to adults.', *Journal of Personality*

- and Social Psychology; Journal of Personality and Social Psychology*, vol. 48, no. 5, p. 1290.
- Salmeto, A, Hymel, K, Carpenter, E, Brilot, B, Bateson, M & Sufka, K 2010, 'Cognitive bias in the chick anxiety-depression model', *Brain Research*, vol. 1373, pp 124-130.
- Salvin, HE, McGreevy, PD, Sachdev, PS & Valenzuela, MJ 2011, 'Growing old gracefully-Behavioral changes associated with "successful aging" in the dog, *Canis familiaris*', *Journal of Veterinary Behavior: Clinical Applications and Research*, vol. 6, no. 6, pp. 313–320.
- Salvin, HE, McGreevy, PD, Sachdev, PS & Valenzuela, MJ 2012, 'The effect of breed on age-related changes in behavior and disease prevalence in cognitively normal older community dogs, *Canis lupus familiaris*', *Journal of Veterinary Behavior: Clinical Applications and Research*, vol. 7, no. 2, pp. 61–69.
- Sandem, A & Braastad, B 2005, 'Effects of cow-calf separation on visible eye white and behaviour in dairy cows--A brief report', *Applied Animal Behaviour Science*, vol. 95, no. 3-4, pp. 233–239.
- Schalke, E, Stichnoth, J, Ott, S & Jones-Baade, R 2007, 'Clinical signs caused by the use of electric training collars on dogs in everyday life situations', *Applied Animal Behaviour Science*, vol. 105, no. 4, pp. 369–380.
- Scheier, M & Carver, C 1985, 'Optimism, coping and health: assessment and implications of general outcome expectancies', *Health Psychology*, vol. 4, no. 3, pp. 219–247.
- Scheier, MF, Carver, CS & Bridges, MW 1994, 'Distinguishing optimism from neuroticism (and trait anxiety, self-mastery, and self-esteem): a reevaluation of the Life Orientation Test.', *Journal of Personality and Social Psychology*, vol. 67, no. 6, pp. 1063–1078.
- Schenkel, R 1967, 'Submission: its features and function in the wolf and dog', *American Zoologist*, vol. 7, no. 2, pp. 319–329.
- Schilder, MBH & van der Borg, JAM 2004, 'Training dogs with help of the shock collar: short and long term behavioural effects', *Applied Animal Behaviour Science*, vol. 85, no. 3-4, pp. 319–334.
- Schmied, C, Waiblinger, S, Scharl, T, Leisch, F & Boivin, X 2008, 'Stroking of different body regions by a human: Effects on behaviour and heart rate of dairy cows', *Applied Animal Behaviour Science*, vol. 109, no. 1, pp. 25–38.
- Schmutz, SM & Schmutz, JK 1998, 'Heritability estimates of behaviors associated with hunting in dogs.', *The Journal of heredity*, vol. 89, no. 3, pp. 233–237.
- Schou, I., Ekenberg, O., Ruland, C.M., Sandvik, L., Kåresen, R., 2004. 'Pessimism as a predictor of emotional morbidity one year following breast cancer surgery'. *Psychooncology*, vol. 13, no. 5, pp.309–320.

- Schwab, C & Huber, L 2006, 'Obey or Not Obey? Dogs (*Canis familiaris*) Behave Differently in Response to Attentional States of Their Owners.', *Journal of Comparative Psychology*, vol. 120, no. 3, pp. 169–175.
- Scott, J & Fuller, J 1965, 'Genetics and Social Behavior of the Dog', *The University of Chicago Press, Chicago and London*.
- Seksel, K, Mazurski, EJ & Taylor, A 1999, 'Puppy socialisation programs: short and long term behavioural effects', *Applied Animal Behaviour Science*, vol. 62, no. 4, pp. 335–349.
- Seligman, M & Csikszentmihalyi, M 2000, 'Positive Psychology An Introduction', *American Psychologist*, vol. 55, no. 1, pp. 5–14.
- Seligman, ME 1968, 'Chronic fear produced by unpredictable electric shock.', *Journal of Comparative and Physiological Psychology*, vol. 66, no. 2, pp. 402–411.
- Seligman, MEP & Johnston, JC 1973, 'A cognitive theory of avoidance learning', in F McGuigan, J Lumsden, & D Barry (eds), *Contemporary approaches to conditioning and learning XII*, V.H. Winston & Sons, Oxford, England.
- Semyonova, A 2003, 'The social organization of the domestic dog; a longitudinal study of domestic canine behavior and the ontogeny of domestic canine social systems', accessed July 4, 2013, from <<http://www.nonlineardogs.com/socialorganisation.html>>.
- Serpell, JA 1995, *The domestic dog: its evolution, behaviour, and interactions with people*, Cambridge University Press, Cambridge, New York.
- Serpell, JA & Hsu, Y 2005, 'Effects of breed, sex, and neuter status on trainability in dogs', *Anthrozoos: A Multidisciplinary Journal of The Interactions of People & Animals*, vol. 18, no. 3, pp. 196–207.
- Sgoifo, A, De Boer, SF, Haller, J & Koolhaas, JM 1996, 'Individual Differences in Plasma Catecholamine and Corticosterone Stress Responses of Wild-Type Rats: Relationship With Aggression', *Physiology & Behavior*, vol. 60, no. 6, pp. 1403–1407.
- Shepherd, K 2002, 'Development of behaviour, social behaviour and communication in dogs', in DF Horwitz, D Mills, & S Heath (eds), *BSAVA Sheppard, G & Mills, D 2002, 'Development of a psychometric scale for the evaluation of the emotional predisposition of pet dogs', International Journal of Comparative Psychology*, vol. 15, no. 2/3, pp. 201–222.
- Sherman, C, Reisner, I, Taliaferro, L & Houpt, K 1996, 'Characteristics, treatment, and outcome of 99 cases of aggression between dogs', *Applied Animal Behaviour Science*, vol. 47, no. 1-2, pp. 91–108.
- Short, KH & Petren, K 2008, 'Boldness underlies foraging success of invasive *Lepidodactylus lugubris* geckos in the human landscape', *Animal Behaviour*,

- vol. 76, no. 2, pp. 429–437.
- Sidman, M 1953, 'Avoidance Conditioning with Brief Shock and No Exteroceptive Warning Signal', *Science*, vol. 118, no. 3058, pp. 157–158.
- Sinn, D, Moltschaniwskyj, N, Wapstra, E & Dall, S 2010, 'Are behavioral syndromes invariant? Spatiotemporal variation in shy/bold behavior in squid', *Behavioral Ecology and Sociobiology*, no. 64, pp. 693–702.
- Sinn, DL, Gosling, SD & Hilliard, S 2010, 'Personality and performance in military working dogs: Reliability and predictive validity of behavioral tests', *Applied Animal Behaviour Science*, vol. 127, no. 1-2, pp. 51–65.
- Skinner, JS 2010, *The Dog and the Sportsman: Embracing the Uses, Breeding, Training, Diseases, Etc., Etc., of Dogs, and an Account of the Different Kinds of Game, With Their Habits. Also Hints to Shooters, with Various Useful Recipes, Etc., Etc*, Read Books Design.
- Slabbert, J & Odendaal, J 1999, 'Early prediction of adult police dog efficiency--a longitudinal study', *Applied Animal Behaviour Science*, vol. 64, no. 4, pp. 269–288.
- Slabbert, JM & Rasa, OAE 1997, 'Observational learning of an acquired maternal behaviour pattern by working dog pups: an alternative training method?', *Applied Animal Behaviour Science*, vol. 53, no. 4, pp. 309–316.
- Smith, JE & Levis, DJ 1991, 'Is fear present following sustained asymptotic avoidance responding?', *Behavioural Processes*, vol. 24, no. 1, pp. 37–47.
- Snider, K 2007, 'A constructional canine aggression treatment: Using a negative reinforcement shaping procedure with dogs in home and community settings.', pp. 1–60.
- Solomon, R, Kamin, LJ & Wynne, LC 1953, 'Traumatic avoidance learning: the outcomes of several extinction procedures with dogs', *Journal of Abnormal Psychology*, no. 48, pp. 291–302.
- Soproni, K, Miklósi, Á, Topál, J & Csányi, V 2001, 'Comprehension of human communicative signs in pet dogs (*Canis familiaris*).', *Journal of Comparative Psychology*, vol. 115, no. 2, pp. 122–126.
- Soproni, K, Miklósi, Á, Topál, J & Csányi, V 2002, 'Dogs' (*Canis familiaris*) responsiveness to human pointing gestures.', *Journal of Comparative Psychology*, vol. 116, no. 1, pp. 27–34.
- Starr, MD & Mineka, S 1977, 'Determinants of fear over the course of avoidance learning', *Learning and Motivation*, vol. 8, no. 3, pp. 332–350.
- Steinker, A 2007, 'Terminology Think Tank: Social dominance theory as it relates to dogs', *Journal of Veterinary Behavior: Clinical Applications and Research*, vol. 2, no. 4, pp. 137–140.

- Stewart, G 2011, *Behavior Adjustment Training: BAT for Fear, Frustration and Aggression in Dogs*, Dogwise Publishing, Wenatchee, WA.
- Stoll, G & Parncutt, R 1987, 'Harmonic relationship in similarity judgements of nonsimultaneous complex tones', *Acta Acustica united with Acustica*, vol. 63, no. 2, pp. 111–119.
- Stone, SM 2009, 'Human facial discrimination in horses: can they tell us apart?', *Animal Cognition*, vol. 13, no. 1, pp. 51–61.
- Sutter, NB & Ostrander, EA 2004, 'Dog star rising: the canine genetic system', *Nature Reviews Genetics*, vol. 5, no. 12, pp. 900–910.
- Svartberg, K 2005, 'A comparison of behaviour in test and in everyday life: evidence of three consistent boldness-related personality traits in dogs', *Applied Animal Behaviour Science*, vol. 91, no. 1-2, pp. 103–128.
- Svartberg, K 2006a, 'Breed-typical behaviour in dogs--Historical remnants or recent constructs?', *Applied Animal Behaviour Science*, vol. 96, no. 3-4, pp. 293–313.
- Svartberg, K 2006b, 'Breed-typical behaviour in dogs--Historical remnants or recent constructs?', *Applied Animal Behaviour Science*, vol. 96, no. 3-4, pp. 293–313.
- Svartberg, K 2007, 'Individual Differences in Behaviour - Dog Personality', in P Jensen (ed), *The Behavioural Biology of Dogs*, CAB International, Oxfordshire, UK, pp. 182–207.
- Svartberg, K 2003, 'Personality in Dogs', thesis, available from <<http://www.svartbergs.se/pdf/PersinDogsSummary.PDF> >.
- Svartberg, K 2002, 'Shyness-boldness predicts performance in working dogs', *Applied Animal Behaviour Science*, vol. 79, no. 2, pp. 157–174.
- Svartberg, K & Forkman, B 2002, 'Personality traits in the domestic dog (*Canis familiaris*)', *Applied Animal Behaviour Science*, vol. 79, no. 2, pp. 133–155.
- Svartberg, K, Tapper, I, Temrin, H, Radesäter, T & Thorman, S 2005, 'Consistency of personality traits in dogs', *Animal Behaviour*, vol. 69, no. 2, pp. 283–291.
- Szetei, V, Miklosi, A, Topal, J & Csanyi, V 2003, 'When dogs seem to lose their nose: an investigation on the use of visual and olfactory cues in communicative context between dog and owner', *Applied Animal Behaviour Science*, vol. 83, no. 2, pp. 141–152.
- Tami, G, Torre, C & Compagnucci, M 2011, 'Interpretation of ambiguous spatial stimuli in cats', *Animal Welfare*.
- Taylor, AM, Reby, D & McComb, K 2009, 'Context-Related Variation in the Vocal Growling Behaviour of the Domestic Dog (*Canis familiaris*)', *Ethology*, vol.

115, no. 10, pp. 905–915.

- Taylor, AM, Reby, D & McComb, K 2010, 'Why Do Large Dogs Sound More Aggressive to Human Listeners: Acoustic Bases of Motivational Misattributions', *Ethology*, vol. 116, no. 12, pp. 1155–1162.
- Taylor, WC, Baranowski, T, Klesges, LM, Ey, S, Pratt, C, Rochon, J & Zhou, A 2004, 'Psychometric properties of optimism and pessimism: results from the Girls' Health Enrichment Multisite Studies', *Preventive Medicine*, vol. 38, pp. 69–77.
- Tinbergen, N 1951, *The Study of Instinct*, Oxford University Press, Oxford.
- Titulaer, M, Blackwell, EJ, Mendl, M & Casey, RA 2013, 'ARTICLE IN PRESS', *Applied Animal Behaviour Science*, pp. 1–10.
- Tomkins, LM, McGreevy, PD & Branson, NJ 2010, 'Lack of standardization in reporting motor laterality in the domestic dog (*Canis familiaris*)', *Journal of Veterinary Behavior: Clinical Applications and Research*, vol. 5, no. 5, pp. 235–239.
- Topal, J, Miklosi, A, Csanyi, V & Doka, A 1998, 'Attachment Behavior in Dogs (*Canis familiaris*): A New Application of Ainsworth's (1969) Strange Situation Test', *Journal of Comparative Psychology*, vol. 112, no. 3, pp. 219–229.
- Tortora, DF 1983, 'Safety training: the elimination of avoidance-motivated aggression in dogs.', *Journal of experimental psychology. General*, vol. 112, no. 2, pp. 176–214.
- Truss, M & Beato, M 1993, 'Steroid hormone receptors: interaction with deoxyribonucleic acid and transcription factors', *Endocrine Reviews*, vol. 14, no. 4, pp. 459–479.
- Tuber, DS, Hennessy, MB, Sanders, S & Miller, JA 1996, 'Behavioral and glucocorticoid responses of adult domestic dogs (*Canis familiaris*) to companionship and social separation.', *Journal of Comparative Psychology*, vol. 110, no. 1, pp. 103–108.
- Turcsán, B., Kubinyi, E. & Miklósi, Á., 2011. 'Trainability and boldness traits differ between dog breed clusters based on conventional breed categories and genetic relatedness'. *Applied Animal Behaviour Science*, vol. 132, no. 1-2, pp.61–70.
- van Kerkhove, W., 2004. 'A fresh look at the wolf-pack theory of companion-animal dog social behavior'. *Journal of applied animal welfare science*, vol. 7, no. 4, pp.279–85– discussion 299–300.
- Vas, J, Topál, J, Gácsi, M, Miklósi, Á & Csányi, V 2005, 'A friend or an enemy? Dogs' reaction to an unfamiliar person showing behavioural cues of threat and friendliness at different times', *Applied Animal Behaviour Science*, vol. 94, no. 1-2, pp. 99–115.

- Verbeek, MEM, Drent, PJ & Wiepkema, PR 1994, 'Consistent individual differences in early exploratory behaviour of male great tits.', *Applied Animal Behaviour Science*, vol. 48, no. 5, pp. 1113–1121.
- Vilà, C, Savolainen, P, Maldonado, JE, Amorim, IR, Rice, JE, Honeycutt, RL, Crandall, KA, Lundeberg, J & Wayne, RK 1997, 'Multiple and ancient origins of the domestic dog.', *Science*, vol. 276, no. 5319, pp. 1687–1689.
- Vinuela-Fernández, I, Jones, E, Welsh, E & Fleetwood-Walker, S 2007, 'Pain mechanisms and their implication for the management of pain in farm and companion animals', *The Veterinary Journal*, vol. 174, no. 2, pp. 227–239.
- Voith, VL 2009, 'The Impact of Companion Animal Problems on Society and the Role of Veterinarians', *Veterinary Clinics of North America: Small Animal Practice*, vol. 39, no. 2, pp. 327–345.
- von Holdt, BM, Pollinger, JP, Lohmueller, KE, Han, E, Parker, HG, Quignon, P, Degenhardt, JD, Boyko, AR, Earl, DA, Auton, A, Reynolds, A, Bryc, K, Brisbin, A, Knowles, JC, Mosher, DS, Spady, TC, Elkahloun, A, Geffen, E, Pilot, M, Jedrzejewski, W, Greco, C, Randi, E, Bannasch, D, Wilton, A, Shearman, J, Musiani, M, Cargill, M, Jones, PG, Qian, Z, Huang, W, Ding, Z-L, Zhang, Y-P, Bustamante, CD, Ostrander, EA, Novembre, J & Wayne, RK 2010, 'Genome-wide SNP and haplotype analyses reveal a rich history underlying dog domestication', *Nature*, vol. 464, no. 7290, pp. 898–902.
- Wahlgren, K & Lester, D 2003, 'The Big Four: Personality in Dogs', *Psychological Reports*, vol. 92, no. 3, p. 828.
- Warren, BS, Wakshlag, JJ, Maley, M, Farrell, TJ, Struble, AM, Panasevich, MR & Wells, MT 2011, 'Use of pedometers to measure the relationship of dog walking to body condition score in obese and non-obese dogs', *British Journal of Nutrition*, vol. 106, no. S1, pp. S85–S89
- Weber, D., 2011. Objectively measured free-living physical activity in pet dogs: Relationships to body condition score and owner-pet activity. Colorado: Colorado State University.
- Weisman, RG & Litner, JS 1969, 'Positive conditioned reinforcement of Sidman avoidance behavior in rats.', *Journal of Comparative and Physiological Psychology*, vol. 68, no. 4, p. 597.
- Weiss, Andreas & Penzlin, H 1985, 'A comparison of shock avoidance learning in headless cockroaches in leg-lifting and lowering task', *Physiology & Behavior*, vol. 34, no. 5, pp. 697–703.
- Welk, GJ, McClain, J & Ainsworth, BE 2012, 'Protocols for evaluating equivalency of accelerometry-based activity monitors', *Medicine and Science in Sports and Exercise*, vol. 44, no. 1S, pp. S39–S49.
- Williams, LM, Phillips, ML, Brammer, MJ, Skerrett, D, Lagopoulos, J, Rennie, C, Bahramali, H, Olivieri, G, David, AS, Peduto, A & Gordon, E 2001, 'Arousal

- Dissociates Amygdala and Hippocampal Fear Responses: Evidence from Simultaneous fMRI and Skin Conductance Recording', *NeuroImage*, vol. 14, no. 5, pp. 1070–1079.
- Willner, P 1997, 'Validity, reliability and utility of the chronic mild stress model of depression: a 10-year review and evaluation', *Psychopharmacology*, vol. 134, no. 4, pp. 319–329.
- Wilson, S, Clark, A, Coleman, K & Dearstyne, T 1994, 'Shyness and boldness in humans and other animals', *Trends in Ecology & Evolution*, vol. 9, no. 11, pp. 442–446.
- Wilsson, E & Sundgren, P 1997, 'The use of a behaviour test for the selection of dogs for service and breeding, I: Method of testing and evaluating test results in the adult dog, demands on different kinds of service dogs, sex and breed differences', *Applied Animal Behaviour Science*, vol. 53, no. 4, pp. 279–295.
- Wilsson, E & Sundgren, P-E 1998, 'Behaviour test for eight-week old puppies—heritabilities of tested behaviour traits and its correspondence to later behaviour', *Applied Animal Behaviour Science*, vol. 58, no. 1-2, pp. 151–162.
- Wright, JC 2004, 'Comment on van Kerkhove's 'Wolf-Pack Theory'', *Journal of Applied Animal Welfare Science*, vol. 7, no. 4, pp. 295–298.
- Wrubel, K, Moon-Fanelli, A, Maranda, L & Dodman, N 2011, 'Interdog household aggression: 38 cases (2006–2007)', *Journal of the American Veterinary Medical Association*, vol. 238, no. 6, pp. 731–740.
- Yeon, S.C., 2007. 'The vocal communication of canines'. *Journal of Veterinary Behavior: Clinical Applications and Research*, vol. 2, no. 4, pp.141–144.
- Yerkes, R.M. & Dodson, D.D., 1908. 'The relation of strength of stimulus to rapidity of habit-formation'. *Journal of Comparative Neurology and Psychology*, vol. 18, no. 5, pp.459–482.
- Yin, S., 2002. 'A new perspective on barking in dogs (*Canis familiaris*)'. *Journal of Comparative Psychology*, vol. 116, no. 2, pp.189–193.
- Yin, S., 2009. *Low Stress Handling, Restraint and Behavior Modification of Dogs and Cats*, Davis, CA: Cattle Dog Publishing.
- Young, R.J., 2003. *Environmental Enrichment for Captive Animals*, Oxford, UK: Blackwell Publishing Ltd.
- Zenger, M. et al., 2010. 'Pessimism Predicts Anxiety, Depression and Quality of Life in Female Cancer Patients'. *Japanese Journal of Clinical Oncology*, vol. 41, no. 1, pp.87–94.
- Zieliński, K. & Plewako, M., 1980. 'The role of conditioned stimulus termination in short-latency avoidance responding in cats'. *Behavioural Brain Research*, vol. 1, no. 5, pp.379–395.

Zieliński, K., Werka, T. & Nikolaev, E., 1991. 'Intertrial responses of rats in two-way avoidance learning to visual and auditory stimuli'. *Acta neurobiologiae experimentalis*, vol. 51, no. 3-4, pp.71-88.

Zimmerman, P, Lundberg, A, Keeling, L & Koene, P, 2003. 'The effect of an audience on the gakel-call and other frustration behaviours in the laying hen (*Gallus gallus domesticus*)'. *Animal Welfare*, vol. 12, no. 3, pp.315-326.

Zuckerman, M., 1994. *Behavioral expressions and biosocial bases of sensation seeking*, Cambridge: Cambridge University Press.

Appendix 1 Diagrams of Apparatus Versions

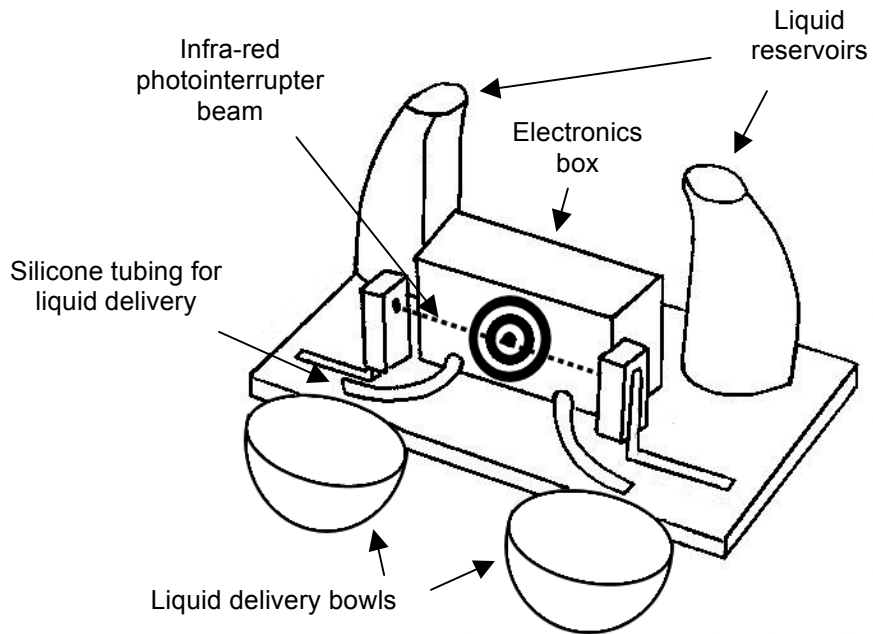

Figure A1.1. Shelf of Apparatus V1.1. This was mounted on brackets attached to a wooden box.

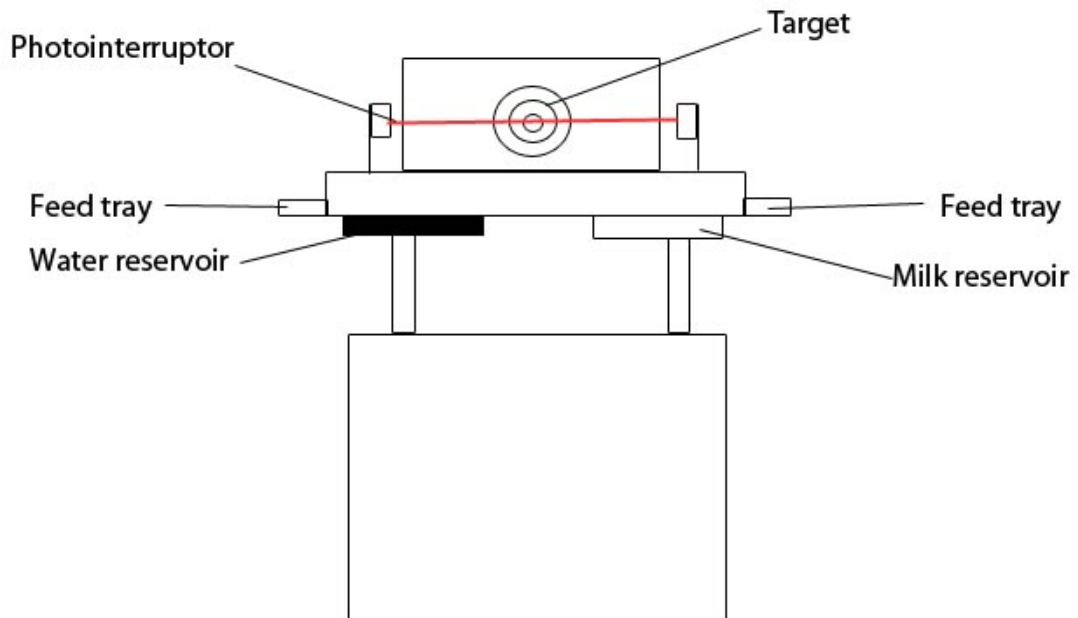

Figure A1.2. Apparatus V1.2. Reservoirs were moved to boxes underneath shelf. Plastic tubing was introduced and housed in metal tubing alongside shelf. Trays moved from front to sides. Volume control was also added.

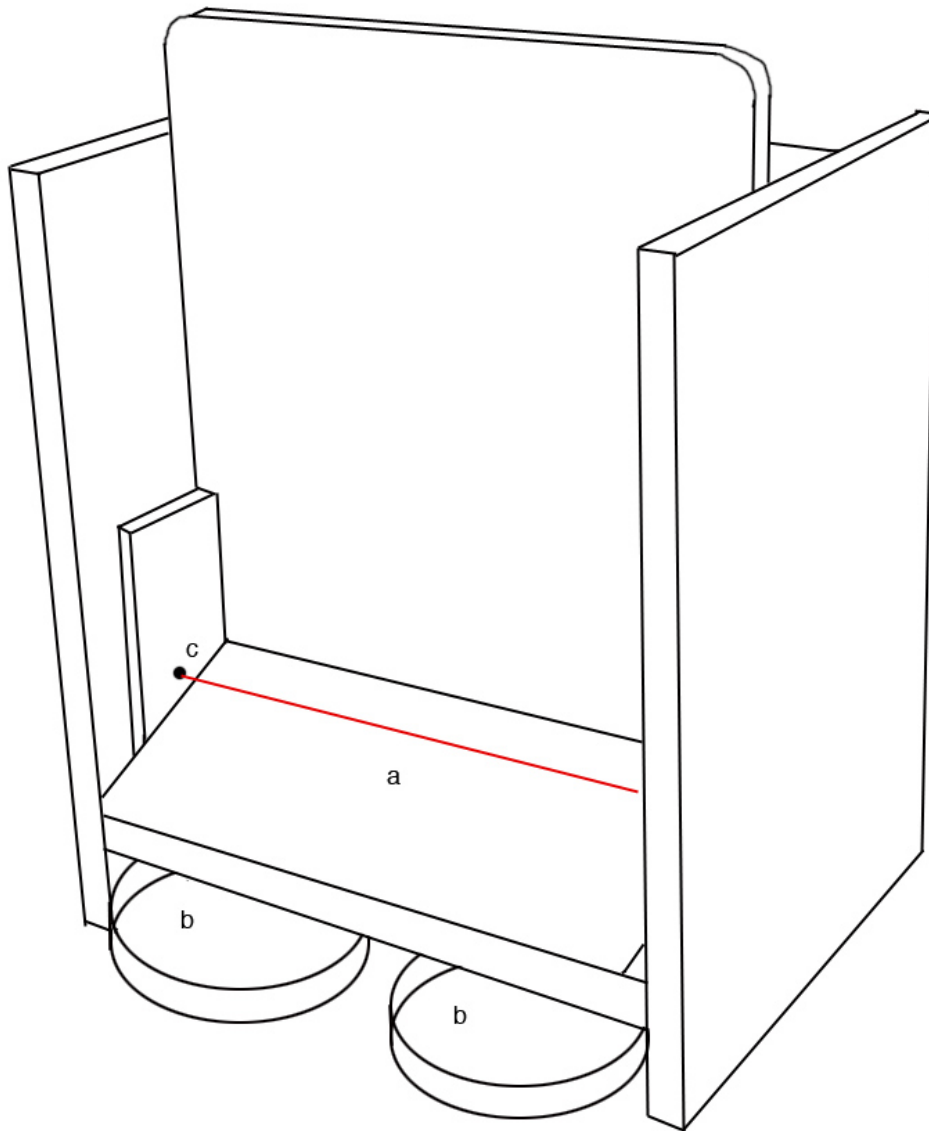

Figure A1.3. Apparatus V2.2. Reservoirs and electronics were housed behind the target on shelves hidden from view by doors. Plastic tubing ran from the pumps on the shelves behind the target, underneath the target and through the wooden base the target is attached to. Target is attached at front by hinges and tubes can be moved to dispense to one tray all the other by lifting the target to access the tubes. Trays returned to front.

Appendix 2 Further information on apparatus components and programming

The apparatus used in this study was designed to be portable and easy for humans to set up and operate. It consists of three major external components. An interactive target that detects movement through the use of an infrared photointerruptor, and two feed trays assigned to either lactose free milk or water. Lactose is the main sugar in milk and its digestion is dependent on the enzyme lactase. Lactase levels in dogs are high when they are young and being fed on milk, but decline once puppies have weaned. A diet high in lactose is known to cause diarrhoea in dogs (Bennett & Coon 1966). Lactose-free milk was therefore chosen as a liquid reward to avoid causing digestive upsets.

Micro Controller

The apparatus prototype was constructed around an Arduino Uno micro-controller board (SmartProjects, Italy). The Arduino Uno controlled an LCD screen (V1.2 and V1.2: DFRobot, Beijing, China; V2.1: FORDATA, China), two peristaltic pumps, six pin buttons (generic manufacturer, part# SP0710) used to set the training program variables, a power switch (generic manufacturer, part #:SK0960), and an infrared photointerruptor. An amplifier (generic manufacturer, part# KC5152), speaker (generic manufacturer, part # AS3000), and associated volume control were also powered off the Arduino Uno. Audio output is provided by an 8 Ω speaker, driven by a Jaycar "The Champ" 0.5W audio amplifier module. A printed circuit board (PCB) was prepared through BatchPCB (SparkFun Electronics, Boulder, Colorado) for version 2.x of the apparatus to reduce the workload of preparing the circuits manually and cut down on wires. A schematic diagram of the all circuits and components is shown in **Figure 1**. Most systems were powered from the Arduino's on-board 5V regulator. The 5V supply is regulated down further to 3V for the LCD module. Level conversion of the I²C data signal from 5V to 3V is performed using two discrete MOSFETs that have a low threshold voltage, following NXP Semiconductors application note AN10441. Power in versions 1.x came either via USB from a computer or from 6 AA batteries. Versions 2.x had higher current requirements due to the larger pumps. The pumps were powered from a separate 6V regulator with a 30°C/W heatsink. The use of a regulated power supply for the pump motors ensured a consistent dosage delivery as the batteries were depleted. Versions 2.x ran exclusively on 8 AA NiMH batteries.

Photointerruptor

The photointerruptor consisted of an infrared LED (OSRAM, Malaysia) and a phototransistor (VISHAY, Germany). The LED used is a 5mm infra-red LED with a peak wavelength of 850nm and a maximum voltage of 1.5V, making it brighter than ambient sunlight when 20cm from the phototransistor. Power to the LED was pulsed to allow background subtraction to be performed in software. The pulse time of the LED was set as 100 μ s to avoid melting the LED. The ampere was set at 89mA to ensure the safety of the apparatus and dogs using it even if a fault developed in the microcontroller that resulted in the LED being lit

continuously rather than in pulses. The phototransistor used was a 5mm, 850nm type component with a sensitivity of 10mA at 1mW per cm². This made it most sensitive to the wavelength emitted by the LED. A plastic cover with a 1mm hole drilled in the centre was used in versions 1.x to create an aperture that was needed to reduce the phototransistor's sensitivity. The LED and phototransistor were mounted within wood in versions 2.x. They were recessed, so no aperture was required.

Pumps and Reservoirs

Peristaltic pumps were used because they could deliver small amounts of liquid and they worked by compressing a silicone delivery tube, thus ensuring the tubes were always primed and liquid delivered the moment the pump was activated. The pumps were calibrated by measuring the volume of liquid they dispensed in a second. They were connected to two Arduino Uno output pins and controlled by the Arduino program. Versions 1.x used small pumps salvaged from Inovvi automatic soap dispensers (generic manufacturer, part # GH1187). These pumps had a flow rate of approximately 60mL/minute. Pumps were upgraded in versions 2.x to larger units with quieter motors (SmallPumps, Arlington, Texas, USA; part # SP200 517, distributed through APT Instruments, Illinois, USA). The flow rate on these versions was approximately 100 mL/minute.

The pumps were connected to reservoirs and to the milk and water trays via 3mm plastic tubing. In V1.1, the reservoirs were in the form of hard plastic containers mounted on either side of the target. In V1.2, reservoirs were in the form of 500mL Intravenous (IV) bags secured in plastic containers underneath the shelf where the target and photointerruptor were mounted. The IV bags were carried over into V2.1 and hung internally where they could drain naturally.

Programming

Programming was written using the open-source Arduino programming environment. The basic programming of each phase is best described through the state machine diagrams shown in **Figure 2**. The judgement bias test phase was more complicated and required an algorithm to ensure all probes were presented twice but still randomly.

a) TP1

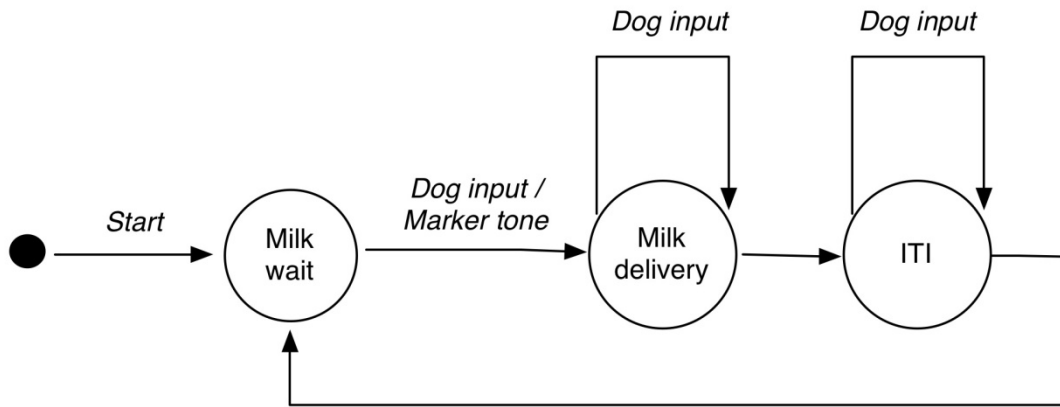

b) TP2

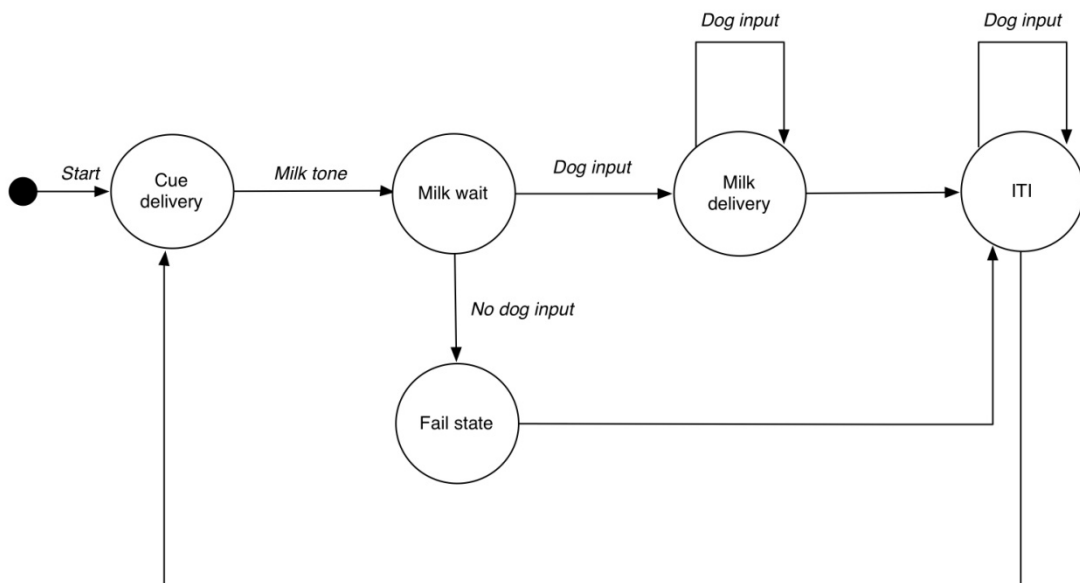
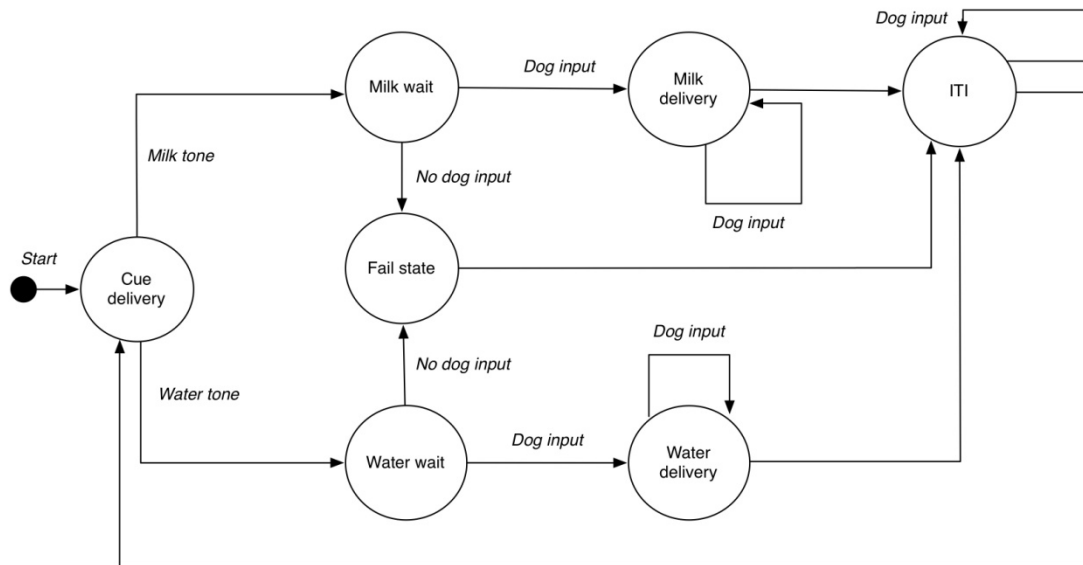

Figure A2.2 a) and b). Finite state machine diagrams describing simple programming rules using states in circles and inputs on arrows. A) shows first training phase (TP1), and b) shows second (TP2). ITI = inter-trial interval (8s in TP1, 20s TP2). TP2A is not shown as it is the same as TP2 except that the ITI in TP2A is 30s.

c) TP3



d) CBT

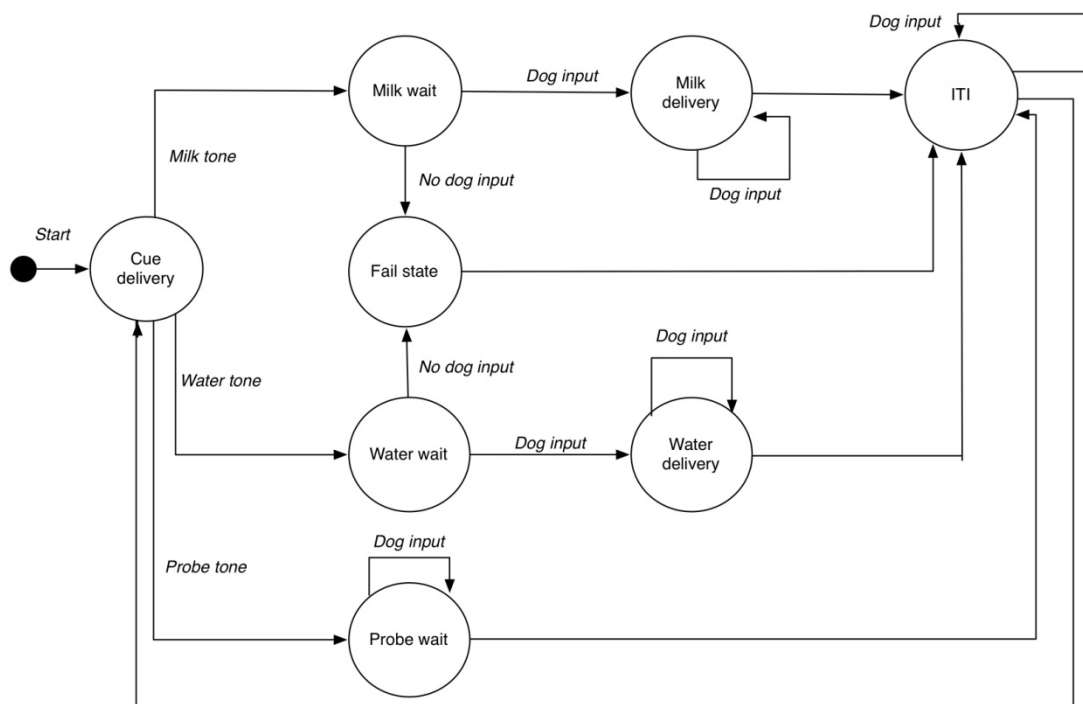

Figure A2.2 c) and d). Finite state machine diagrams describing simple programming rules using states in circles and inputs on arrows. C) shows TP3 and d) shows CBT, or cognitive bias testing phase. ITI = 20s in both phases.

Appendix 3 Response Latency Graphs

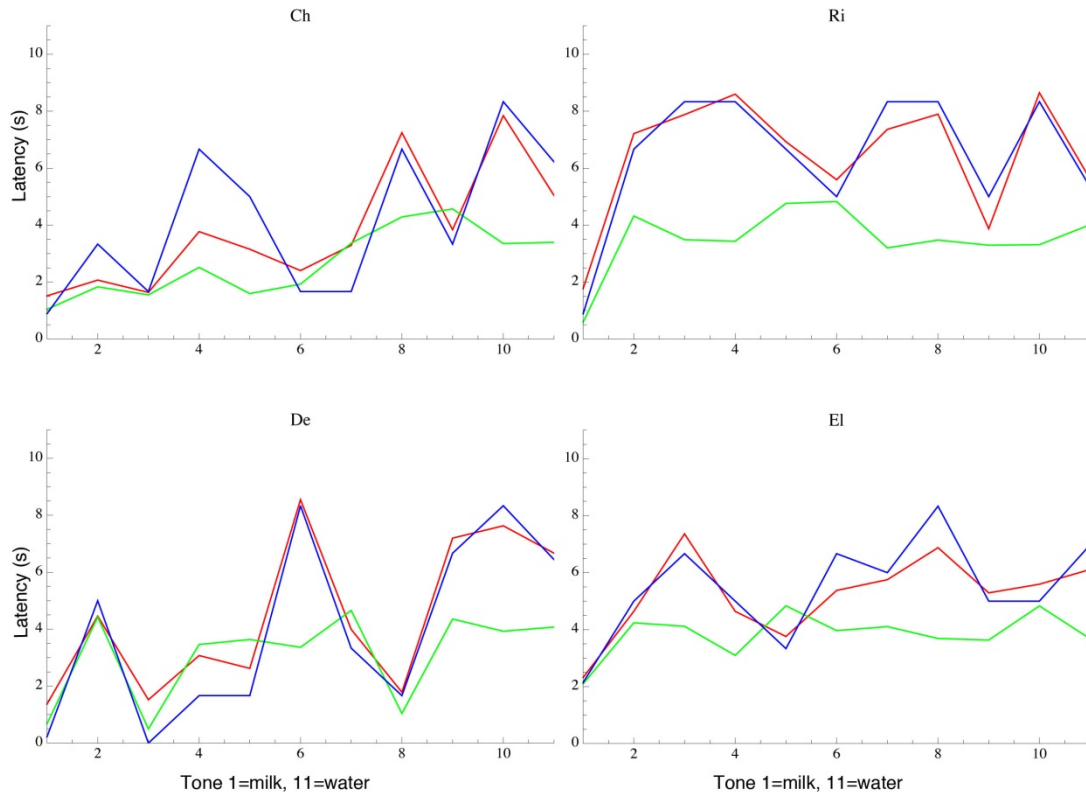

Figure A3.1. Response latency graphs of dogs categorised as optimistic. Tone is shown on the x-axis, numbered from 1=milk to 11=water. Tones 2-10 were probe tones. The y-axis shows latency in seconds. The red line shows average latency, the green line shows variation, and the blue line shows the log(likelihood of a slower than average response). These dogs show high variance that approaches average latency and average latencies higher than the likelihood of a slower than average response.

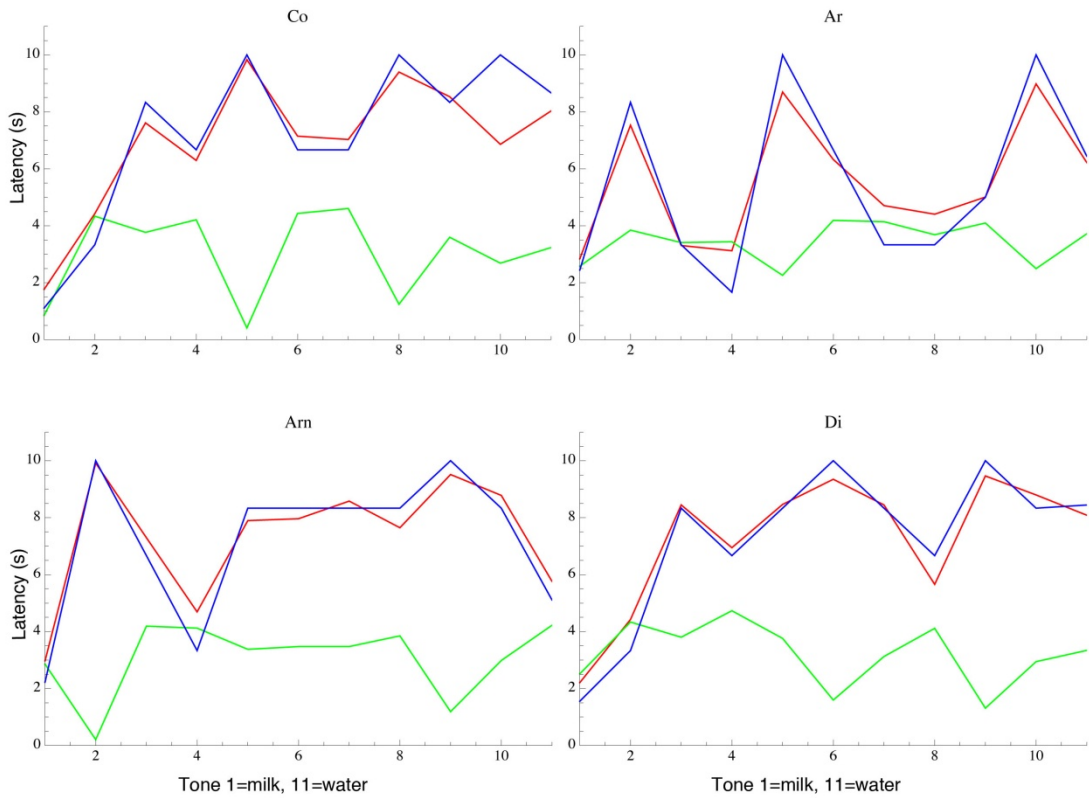

Figure A3.2. Response latency graphs of dogs categorised as moderately optimistic. Tone is shown on the x-axis, numbered from 1=milk to 11=water. Tones 2-10 were probe tones. The y-axis shows latency in seconds. The red line shows average latency, the green line shows variation, and the blue line shows the log(likelihood of a slower than average response).

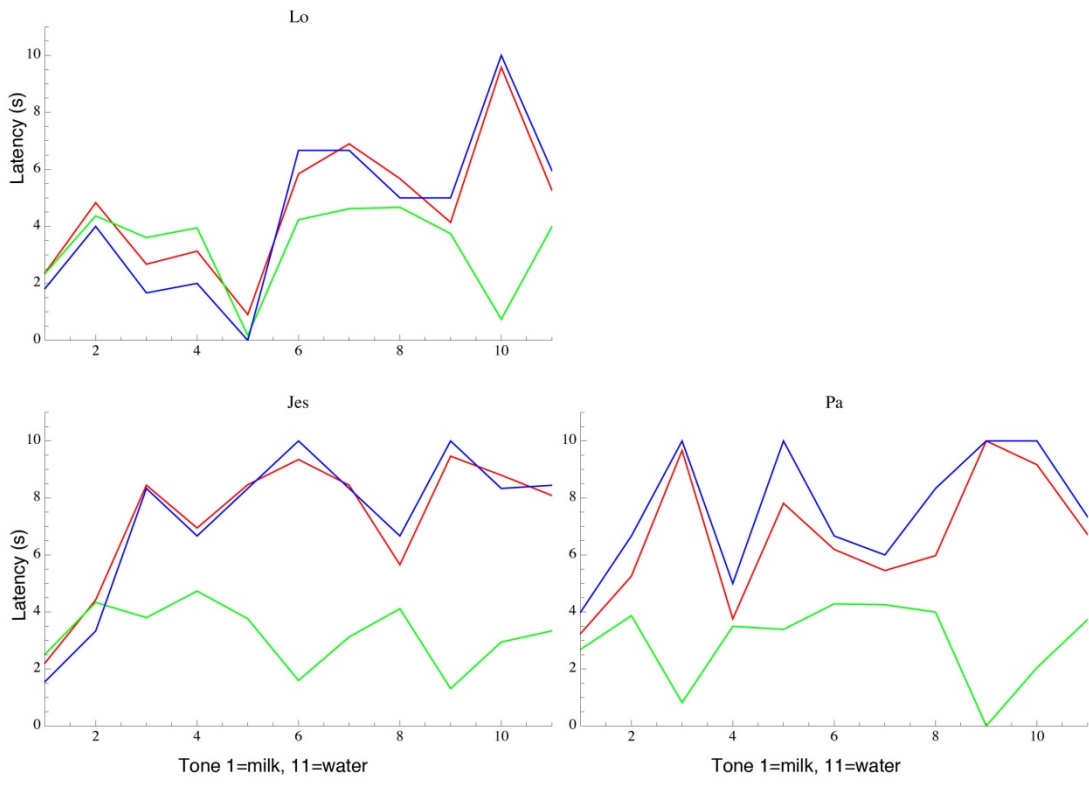

Figure A3.3. Response latency graphs of dogs categorised as balanced. Tone is shown on the x-axis, numbered from 1=milk to 11=water. Tones 2-10 were probe tones. The y-axis shows latency in seconds. The red line shows average latency, the green line shows variation, and the blue line shows the log(likelihood of a slower than average response).

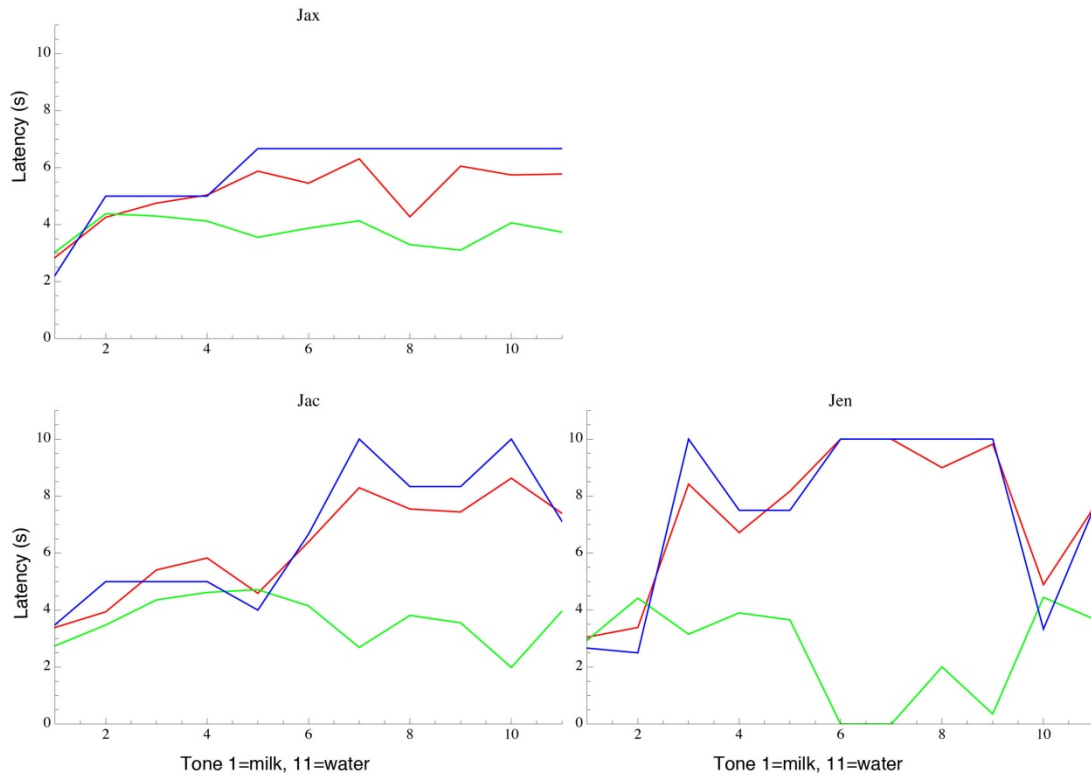

Figure A3.4. Response latency graphs of dogs categorised as moderately pessimistic. Tone is shown on the x-axis, numbered from 1=milk to 11=water. Tones 2-10 were probe tones. The y-axis shows latency in seconds. The red line shows average latency, the green line shows variation, and the blue line shows the log(likelihood of a slower than average response).

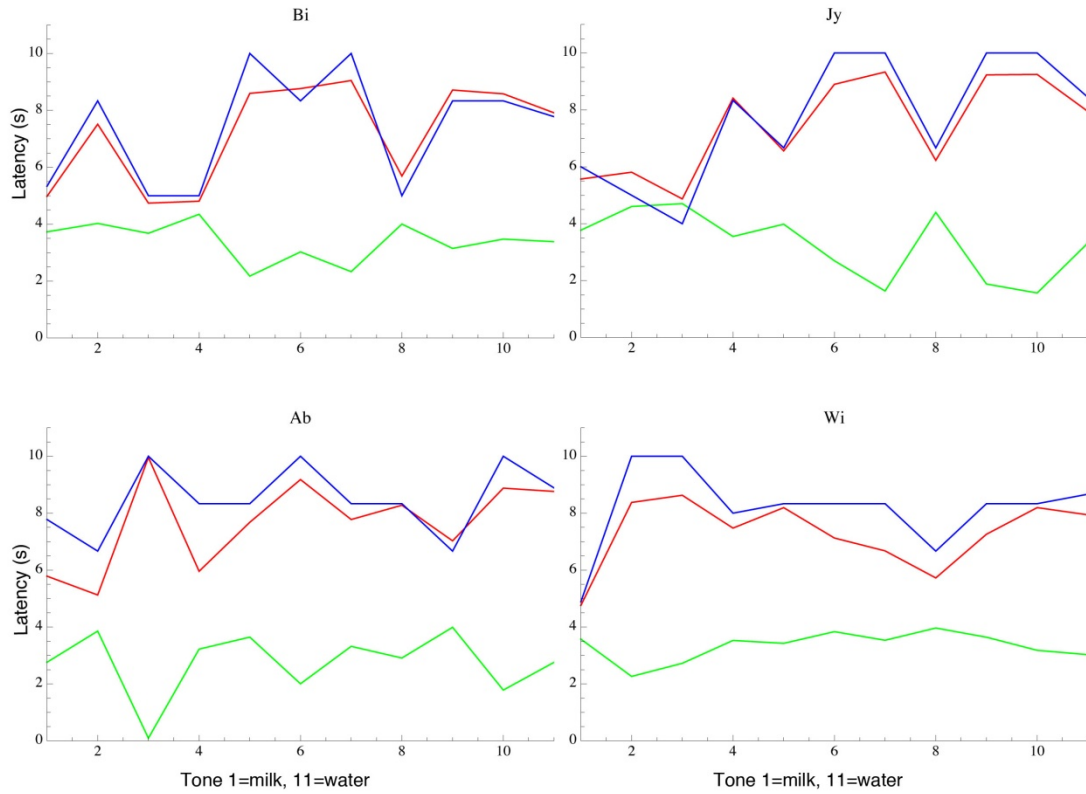

Figure A3.5. Response latency graphs of dogs categorised as pessimistic. Tone is shown on the x-axis, numbered from 1=milk to 11=water. Tones 2-10 were probe tones. The y-axis shows latency in seconds. The red line shows average latency, the green line shows variation, and the blue line shows the $\log(\text{likelihood of a slower than average response})$. These dogs do not show tipping points, but are characterised by high average latencies and low variance.

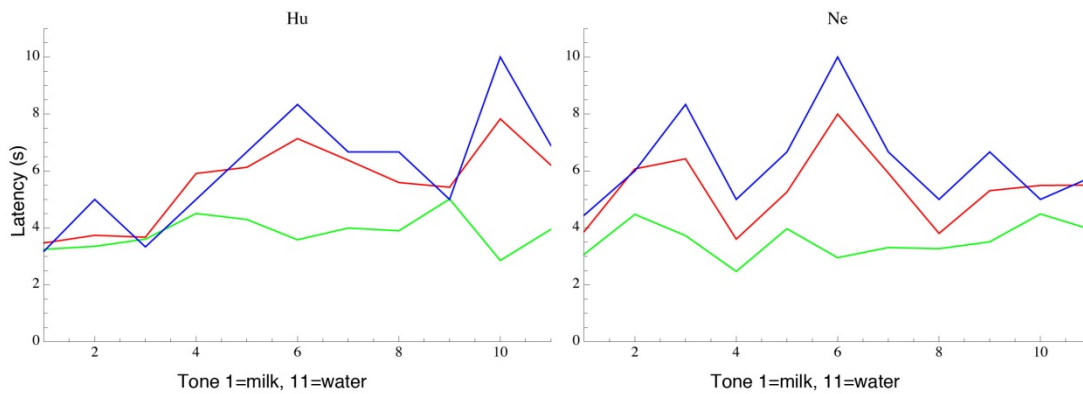

Figure A3.6. Response latency graphs of dogs uncategorised. Tone is shown on the x-axis, numbered from 1=milk to 11=water. Tones 2-10 were probe tones. The y-axis shows latency in seconds. The red line shows average latency, the green line shows variation, and the blue line shows the $\log(\text{likelihood of a slower than average response})$. These dogs do not show tipping points but also do not show high average latencies that characterise pessimistic dogs.

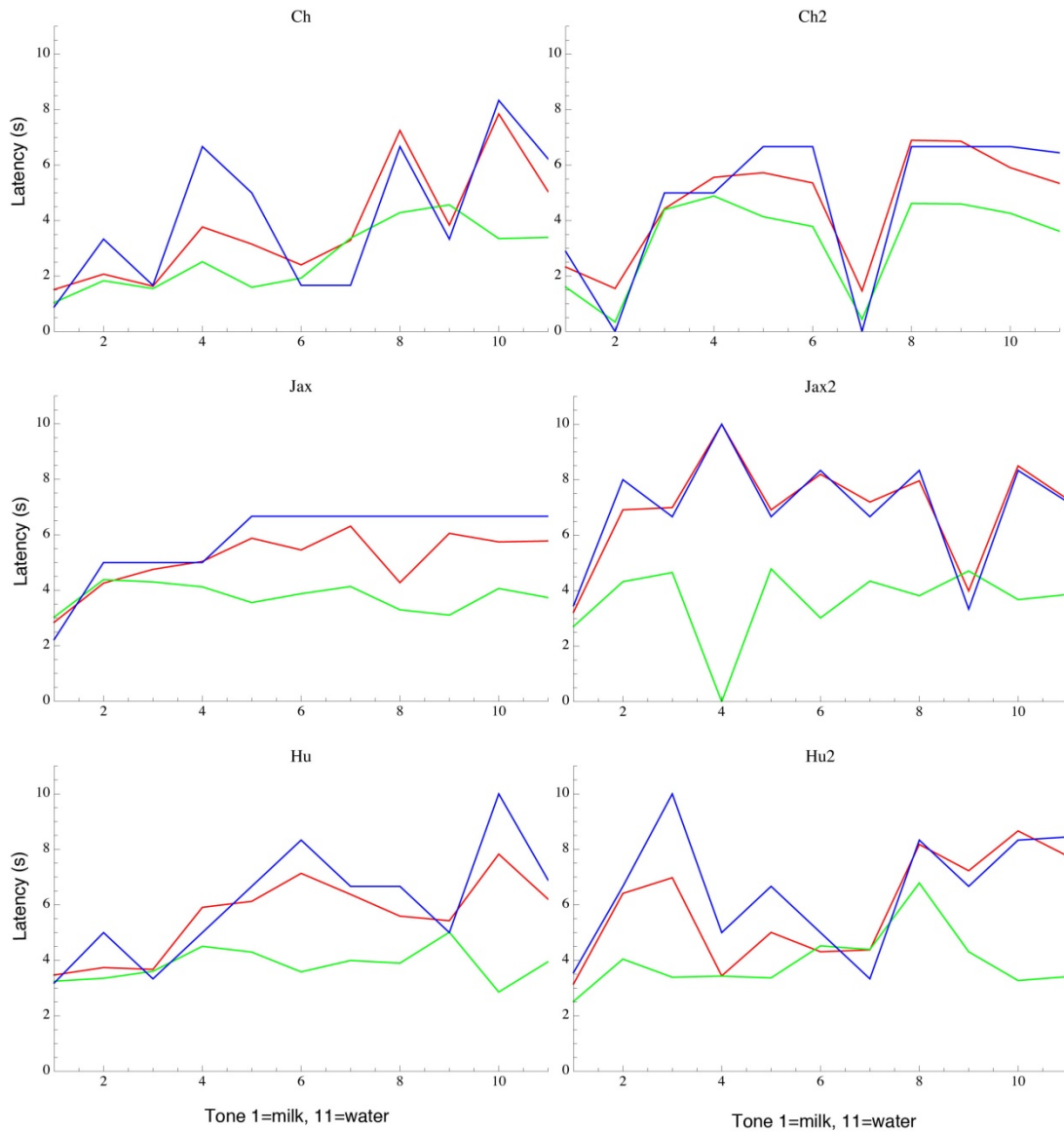

Figure A3.7. Response latency graphs of dogs that were retested. Tone is shown on the x-axis, numbered from 1=milk to 11=water. Tones 2-10 were probe tones. The y-axis shows latency in seconds. The red line shows average latency, the green line shows variation, and the blue line shows the log(likelihood of a slower than average response). First test is shown in the left column and second test is shown in the right. Ch and Jax were retested 4 months after the first tests, and Hu was retested 6 months after the first tests. Ch was categorised as optimistic in both cases. Jax was categorised as moderately pessimistic in first tests and optimistic in second. Hu was uncategorised in first test and categorised as optimistic in second. Increased variance in the second tests may indicate dogs are making decisions more quickly in the second tests.

Appendix 4 Copy of survey referred to in Chapters 3 and 4

Introduction

This survey should be answered by one person and refer to one dog. If you have more than one dog, an additional survey may be filled out for each additional dog if you wish.

Please answer the following introductory questions about you and the dog you are filling out the survey for. Circle the most appropriate option where multiple options are offered.

Your age: 18-29 30-44 45-59 60+

Your gender: Male Female

Your dog's age: Years____ Months____

Your dog's gender: Male Female

Your dog is: Desexed Entire

Your dog's breed(s):

Where did you obtain your dog? Pound or shelter Breeder Family or friend Pet store
Other

How old was your dog when you acquired him/her? <1 year 1-3 years 4-6 years
>6 years

Section 1. Trainability

Please give a general indication of how trainable and obedient your dog is in the following situations by ticking the appropriate boxes.

| | Never | Seldom | Sometimes | Usually | Always |
|--|--------------------------|--------------------------|--------------------------|--------------------------|--------------------------|
| 1. When off the leash, returns immediately when called. | <input type="checkbox"/> | <input type="checkbox"/> | <input type="checkbox"/> | <input type="checkbox"/> | <input type="checkbox"/> |
| 2. Obeys the "sit" command immediately. | <input type="checkbox"/> | <input type="checkbox"/> | <input type="checkbox"/> | <input type="checkbox"/> | <input type="checkbox"/> |
| 3. Obeys the "stay" command immediately. | <input type="checkbox"/> | <input type="checkbox"/> | <input type="checkbox"/> | <input type="checkbox"/> | <input type="checkbox"/> |
| 4. Seems to attend/listen closely to everything you say or do. | <input type="checkbox"/> | <input type="checkbox"/> | <input type="checkbox"/> | <input type="checkbox"/> | <input type="checkbox"/> |
| 5. Slow to respond to correction or punishment; 'thick-skinned'. | <input type="checkbox"/> | <input type="checkbox"/> | <input type="checkbox"/> | <input type="checkbox"/> | <input type="checkbox"/> |
| 6. Slow to learn new tricks or tasks. | <input type="checkbox"/> | <input type="checkbox"/> | <input type="checkbox"/> | <input type="checkbox"/> | <input type="checkbox"/> |
| 7. Easily distracted by interesting sights, sounds or smells. | <input type="checkbox"/> | <input type="checkbox"/> | <input type="checkbox"/> | <input type="checkbox"/> | <input type="checkbox"/> |

| | | | | | |
|--|--------------------------|--------------------------|--------------------------|--------------------------|--------------------------|
| 8. Will 'fetch' or attempt to fetch sticks, balls, or objects. | <input type="checkbox"/> | <input type="checkbox"/> | <input type="checkbox"/> | <input type="checkbox"/> | <input type="checkbox"/> |
| 9. Often highly excited e.g. barking or other signs of excitement. | <input type="checkbox"/> | <input type="checkbox"/> | <input type="checkbox"/> | <input type="checkbox"/> | <input type="checkbox"/> |
| 10. Persists with an activity even after unrewarding or punishing consequences. | <input type="checkbox"/> | <input type="checkbox"/> | <input type="checkbox"/> | <input type="checkbox"/> | <input type="checkbox"/> |
| 11. Immobilises (freezes, lies down, won't move). | <input type="checkbox"/> | <input type="checkbox"/> | <input type="checkbox"/> | <input type="checkbox"/> | <input type="checkbox"/> |
| 12. Breaks from stationary positions (down, sit, stay etc.) before being released. | <input type="checkbox"/> | <input type="checkbox"/> | <input type="checkbox"/> | <input type="checkbox"/> | <input type="checkbox"/> |

SECTION 2: Fear and Anxiety

Using the following 5-point scales (0=No fear, 4=Extreme fear), please indicate your dog's recent tendency to display fearful behaviour in each of the following circumstances:

13. When approached directly by an unfamiliar **adult** while away from your home.

| | | | | |
|---|--------|-----------------------------------|---------------------|---|
| <u>No fear/anxiety:</u> No visible signs of fear | 0..... | <u>Mild—Moderate fear/anxiety</u> | 1.....2.....3.....4 | <u>Extreme fear:</u> cowers; retreats or hides, etc. |
|---|--------|-----------------------------------|---------------------|---|

14. When approached directly by an unfamiliar **child** while away from your home.

| | | | | |
|---|--------|-----------------------------------|---------------------|---|
| <u>No fear/anxiety:</u> No visible signs of fear | 0..... | <u>Mild—Moderate fear/anxiety</u> | 1.....2.....3.....4 | <u>Extreme fear:</u> cowers; retreats or hides, etc. |
|---|--------|-----------------------------------|---------------------|---|

15. In response to sudden or loud noises (e.g. vacuum cleaner, car backfire, road drills, objects being dropped, etc.).

| | | | | |
|---|--------|-----------------------------------|---------------------|---|
| <u>No fear/anxiety:</u> No visible signs of fear | 0..... | <u>Mild—Moderate fear/anxiety</u> | 1.....2.....3.....4 | <u>Extreme fear:</u> cowers; retreats or hides, etc. |
|---|--------|-----------------------------------|---------------------|---|

16. When unfamiliar persons visit your home.

| | | | | |
|---|--------|-----------------------------------|---------------------|---|
| <u>No fear/anxiety:</u> No visible signs of fear | 0..... | <u>Mild—Moderate fear/anxiety</u> | 1.....2.....3.....4 | <u>Extreme fear:</u> cowers; retreats or hides, etc. |
|---|--------|-----------------------------------|---------------------|---|

17. When an unfamiliar person tries to touch or pet the dog.

| | | | | |
|---|--------|-----------------------------------|---------------------|---|
| <u>No fear/anxiety:</u> No visible signs of fear | 0..... | <u>Mild—Moderate fear/anxiety</u> | 1.....2.....3.....4 | <u>Extreme fear:</u> cowers; retreats or hides, etc. |
|---|--------|-----------------------------------|---------------------|---|

18. In heavy traffic

| | | |
|-------------------------------|----------------------------|---|
| <u>No fear:</u> No visible | <u>Mild— Moderate fear</u> | <u>Extreme fear:</u> cowers; retreats or |
|-------------------------------|----------------------------|---|

signs of fear 0.....1.....2.....3.....4 hides, etc.

19. In response to strange or unfamiliar objects on or near the sidewalk (e.g. plastic trash bags, leaves, litter, flags flapping, etc.)

| | | |
|--|---|--|
| <u>No fear:</u> No visible signs of fear | <u>Mild— Moderate fear</u> 0.....1.....2.....3.....4 | <u>Extreme fear:</u> cowers; retreats or hides, etc. |
|--|---|--|

20. When examined/treated by a veterinarian.

| | | |
|--|--|--|
| <u>No fear/anxiety:</u> No visible signs of fear | <u>Mild—Moderate fear/anxiety</u> 0.....1.....2.....3.....4 | <u>Extreme fear:</u> cowers; retreats or hides, etc. |
|--|--|--|

21. During thunderstorms, firework displays, or similar events.

| | | |
|--|--|--|
| <u>No fear/anxiety:</u> No visible signs of fear | <u>Mild—Moderate fear/anxiety</u> 0.....1.....2.....3.....4 | <u>Extreme fear:</u> cowers; retreats or hides, etc. |
|--|--|--|

22. When approached directly by an unfamiliar dog of the same or larger size when away from home.

| | | |
|--|--|--|
| <u>No fear/anxiety:</u> No visible signs of fear | <u>Mild—Moderate fear/anxiety</u> 0.....1.....2.....3.....4 | <u>Extreme fear:</u> cowers; retreats or hides, etc. |
|--|--|--|

23. When approached directly by an unfamiliar dog of a smaller size when away from home.

| | | |
|--|--|--|
| <u>No fear/anxiety:</u> No visible signs of fear | <u>Mild—Moderate fear/anxiety</u> 0.....1.....2.....3.....4 | <u>Extreme fear:</u> cowers; retreats or hides, etc. |
|--|--|--|

24. When first exposed to unfamiliar situations (e.g. first car trip, first time in elevator, first visit to veterinarian, etc.)

| | | |
|--|---|--|
| <u>No fear:</u> No visible signs of fear | <u>Mild— Moderate fear</u> 0.....1.....2.....3.....4 | <u>Extreme fear:</u> cowers; retreats or hides, etc. |
|--|---|--|

25. In response to wind or wind-blown objects.

| | | |
|--|---|--|
| <u>No fear:</u> No visible signs of fear | <u>Mild— Moderate fear</u> 0.....1.....2.....3.....4 | <u>Extreme fear:</u> cowers; retreats or hides, etc. |
|--|---|--|

26. When having nails clipped by a household member.

| | | |
|--|---|--|
| <u>No fear:</u> No visible signs of fear | <u>Mild— Moderate fear</u> 0.....1.....2.....3.....4 | <u>Extreme fear:</u> cowers; retreats or hides, etc. |
|--|---|--|

27. When groomed or bathed by a household member.

| | | |
|-------------------------------|----------------------------|---|
| <u>No fear:</u> No visible | <u>Mild— Moderate fear</u> | <u>Extreme fear:</u> cowers; retreats or |
|-------------------------------|----------------------------|---|

signs of fear 0.....1.....2.....3.....4 hides, etc.

28. When stepped over by a member of the household.

| | | | |
|--|---------------------------|-----------------------------------|--|
| <u>No fear/anxiety:</u> No visible signs of fear | 0.....1.....2.....3.....4 | <u>Mild—Moderate fear/anxiety</u> | <u>Extreme fear:</u> cowers; retreats or hides, etc. |
|--|---------------------------|-----------------------------------|--|

29. When having his/her feet towed by a member of the household.

| | | | |
|--|---------------------------|-----------------------------------|--|
| <u>No fear/anxiety:</u> No visible signs of fear | 0.....1.....2.....3.....4 | <u>Mild—Moderate fear/anxiety</u> | <u>Extreme fear:</u> cowers; retreats or hides, etc. |
|--|---------------------------|-----------------------------------|--|

30. When unfamiliar dogs visit your home.

| | | | |
|--|---------------------------|---------------------------|--|
| <u>No fear:</u> No visible signs of fear | 0.....1.....2.....3.....4 | <u>Mild—Moderate fear</u> | <u>Extreme fear:</u> cowers; retreats or hides, etc. |
|--|---------------------------|---------------------------|--|

31. When barked, growled, or lunged at by an unfamiliar dog when away from home.

| | | | |
|--|---------------------------|-----------------------------------|--|
| <u>No fear/anxiety:</u> No visible signs of fear | 0.....1.....2.....3.....4 | <u>Mild—Moderate fear/anxiety</u> | <u>Extreme fear:</u> cowers; retreats or hides, etc. |
|--|---------------------------|-----------------------------------|--|

Section 3: Proactive and Reactive Behaviour

Please indicate the general intensity of the behaviour of your dog in the following scenarios using the scale from 0 to 4.

32. Exploration of unfamiliar places.

| | | | |
|--------------------------------------|---------------------------|---|---|
| <u>Low:</u> Hangs back with owner | 0.....1.....2.....3.....4 | <u>Mild—Moderate exploration slowly</u> | <u>High:</u> Explores at high pace, not staying anywhere for long. |
|--------------------------------------|---------------------------|---|---|

33. Activity in familiar places.

| | | | |
|--|---------------------------|-------------------------------|---|
| <u>Low:</u> Remains immobile with owner. | 0.....1.....2.....3.....4 | <u>Mild—Moderate activity</u> | <u>High:</u> Rarely stops “hunting”, finding items to chew, nosing objects. |
|--|---------------------------|-------------------------------|---|

34. Chase tendency.

| | | | |
|--|---------------------------|-------------------------------------|---|
| <u>Low:</u> Does not chase fast moving objects | 0.....1.....2.....3.....4 | <u>Mild—Moderate chase tendency</u> | <u>High:</u> Chases most fast moving objects. |
|--|---------------------------|-------------------------------------|---|

35. Attention towards signs of known aversive events or objects such as baths, nail clippers, snakes etc.

Low: Does not notice signs of previously aversive events. 0.....1.....2.....3.....4

Mild—Moderate attention

High: Flees or hides at first sign of previously aversive event.

36. Attention towards signs of known rewarding events.

Low: Does not notice. 0.....1.....2.....3.....4

Mild—Moderate attention

High: Becomes excited at first sign of previously rewarding events.

37. Response to changes in familiar surroundings (e.g. rearranged furniture, new family car, new appliance).

Insensitive: accepts changes with little outward signs. 0.....1.....2.....3.....4

Mild—Moderately sensitive

Sensitive: Cautiously explores or avoids change; becomes vocal or destructive.

38. Response to changes in routines (e.g. going to work at a different time).

Insensitive: Accepts change with no outward signs. 0.....1.....2.....3.....4

Mild—Moderately sensitive

Sensitive: Becomes destructive or vocal.

Section 4: Play and Sociability

Record how often your dog generally displays the following social and playful behaviours.

| | Never | Seldom | Sometimes | Usually | Always |
|---|--------------------------|--------------------------|--------------------------|--------------------------|--------------------------|
| 39. Eager to play with family members. | <input type="checkbox"/> | <input type="checkbox"/> | <input type="checkbox"/> | <input type="checkbox"/> | <input type="checkbox"/> |
| 40. Eager to play with strangers. | <input type="checkbox"/> | <input type="checkbox"/> | <input type="checkbox"/> | <input type="checkbox"/> | <input type="checkbox"/> |
| 41. Retrieves objects and initiates play. | <input type="checkbox"/> | <input type="checkbox"/> | <input type="checkbox"/> | <input type="checkbox"/> | <input type="checkbox"/> |
| 42. Eager to play with other desexed male dogs. | <input type="checkbox"/> | <input type="checkbox"/> | <input type="checkbox"/> | <input type="checkbox"/> | <input type="checkbox"/> |
| 43. Eager to play with other entire male dogs. | <input type="checkbox"/> | <input type="checkbox"/> | <input type="checkbox"/> | <input type="checkbox"/> | <input type="checkbox"/> |
| 44. Eager to play with other desexed female dogs. | <input type="checkbox"/> | <input type="checkbox"/> | <input type="checkbox"/> | <input type="checkbox"/> | <input type="checkbox"/> |
| 45. Eager to play with other entire female dogs. | <input type="checkbox"/> | <input type="checkbox"/> | <input type="checkbox"/> | <input type="checkbox"/> | <input type="checkbox"/> |
| 46. Enjoys play wrestling with other dogs. | <input type="checkbox"/> | <input type="checkbox"/> | <input type="checkbox"/> | <input type="checkbox"/> | <input type="checkbox"/> |

| | | | | | |
|---|--------------------------|--------------------------|--------------------------|--------------------------|--------------------------|
| 47. Quick to respond to other dogs' invitations to play. | <input type="checkbox"/> | <input type="checkbox"/> | <input type="checkbox"/> | <input type="checkbox"/> | <input type="checkbox"/> |
| 48. Enjoys tug-of-war with familiar persons. | <input type="checkbox"/> | <input type="checkbox"/> | <input type="checkbox"/> | <input type="checkbox"/> | <input type="checkbox"/> |
| 49. Eager to run after thrown balls. | <input type="checkbox"/> | <input type="checkbox"/> | <input type="checkbox"/> | <input type="checkbox"/> | <input type="checkbox"/> |
| 50. Enjoys affection and interaction with several unfamiliar people at once, either at home or away from home. | <input type="checkbox"/> | <input type="checkbox"/> | <input type="checkbox"/> | <input type="checkbox"/> | <input type="checkbox"/> |
| 51. Greets visiting unfamiliar adults in a friendly manner. | <input type="checkbox"/> | <input type="checkbox"/> | <input type="checkbox"/> | <input type="checkbox"/> | <input type="checkbox"/> |
| 52. Greets visiting unfamiliar children in a friendly manner. | <input type="checkbox"/> | <input type="checkbox"/> | <input type="checkbox"/> | <input type="checkbox"/> | <input type="checkbox"/> |
| 53. Eager to approach unfamiliar adults away from home in a friendly manner. | <input type="checkbox"/> | <input type="checkbox"/> | <input type="checkbox"/> | <input type="checkbox"/> | <input type="checkbox"/> |
| 54. Eager to approach unfamiliar children away from home in a friendly manner. | <input type="checkbox"/> | <input type="checkbox"/> | <input type="checkbox"/> | <input type="checkbox"/> | <input type="checkbox"/> |
| 55. Eager to approach unfamiliar dogs away from home in a friendly manner. | <input type="checkbox"/> | <input type="checkbox"/> | <input type="checkbox"/> | <input type="checkbox"/> | <input type="checkbox"/> |
| 56. Enjoys being petted by strangers when away from home. | <input type="checkbox"/> | <input type="checkbox"/> | <input type="checkbox"/> | <input type="checkbox"/> | <input type="checkbox"/> |
| 57. Barks when other dogs bark. | <input type="checkbox"/> | <input type="checkbox"/> | <input type="checkbox"/> | <input type="checkbox"/> | <input type="checkbox"/> |