

# A genetic and physical map of the short arm of rye chromosome 1 (1RS)

Resch V, Kofler R, Lelley T

*University of Natural Resources and Applied Life Sciences, Department for Agrobiotechnology, Institute for Plant Production Biotechnology, Konrad Lorenz Str. 20, A-3430 Tulln, Austria*

## INTRODUCTION

Apart from the rye (*Secale cereale* L.) genome, the short arm of rye chromosome 1 (1RS) is also present in triticale and in hundreds of wheat varieties world wide as the 1BL.1RS or the 1AL.1RS translocation. Agronomically important genes, such as the self incompatibility locus S, or genes linked to resistances against several rust species and powdery mildew, are located on 1RS.

Genetic maps are an important tool for genome research and plant breeding. Marker assisted selection and mapping of quantitative trait loci (QTLs) are based on reliable genetic maps. Simple sequence repeat (SSR) markers are the preferred molecular markers for constructing genetic maps, as SSR markers are easy-to-use, reliable, and show a codominant segregation.

So far, only few genetic markers have been developed for the rye genome in general, and for 1RS in particular. Kofler et al. (under review) designed 74 primer pairs producing 76 polymorphic loci on 1RS. These markers, referred to as Tulln *Secale* Microsatellite (TSM) markers, were used to construct an SSR based physical and genetic map of 1RS, having the highest marker density reported so far.

In addition to the TSM markers, we aimed to integrate several, already published markers into the genetic, as well as the physical map of 1RS. These markers include the SSR markers Scm1, Scm9, Scm107, Scm127 (Hackauf & Wehling, 2003) and Bmac213 (Ramsay et al., 2000), as well as the STS marker 5S (Koeber, 1995) and the ISBP markers ORA1 – ORA12 (Bartoš, unpublished results). We integrated 22 new SSR markers into the genetic map and 56 into the physical map of 1RS.

## PHYSICAL MAPPING

For physical mapping nine 1RS deletion lines (5, 14, 24, 28, 44, 45, 59, 65, 67) of Tsuchida et al. (2008) were used.

The TSM markers were employed to characterize the 1RS deletion lines and to infer the positions of the chromosomal breakpoints. We found that the breakpoint of deletion line '24' is closest to the centromere, followed by '28', '14', '44', '5', '65', '45' / '67', and finally that the breakpoint of deletion line '59' is farthest from the centromere (Fig. 1). No markers could differentiate between deletion lines '45' and '67'. The nine deletion lines, the wheat genotype Chinese Spring

and the wheat-rye addition line (CS+1RS) were used to mark nine regions (bins) on the 1RS arm, to which temporarily letters from A to I, starting at the centromere, were assigned (Fig. 1). In summary, 56 TSM markers and 9 of the other markers (ORA, Bmac213) were physically mapped to the 1RS chromosome arm. Fig. 1 shows the physical map of 1RS, as well as the positions of the TSM markers, as published by Kofler et al. (under review).

In general, this newly developed physical map (Fig. 1) agrees well with the map reported by Kofler et al. (under review). Only bin E shows inconclusive results, as Kofler et al. (under review) reported that markers of this bin either map to the distal or to the intercalary region of 1RS (Fig. 1). This discrepancy may be due to several chromosomal rearrangements in deletion line '5'.

## GENETIC MAPPING

Genetic mapping was carried out with two F2 populations, each consisting of 96 individuals. The populations were derived from crosses among three rye inbred lines: Sp3 x Hy2 and Sp4 x Hy2. The DNA of these F2 populations and of the parents was kindly provided by Dr. B. Hackauf (Groß Lüsewitz, Germany). In summary, 72 TSM markers were polymorphic between Sp3 x Hy2 and 51 between Sp4 x Hy2. Of these polymorphic markers 38 could be scored in Sp3 x Hy2 and 24 in Sp4 x Hy2. Co-dominant, as well as dominant markers were included.

Genetic mapping was carried out with the software CarthaGène 1.0, setting the minimum LOD score to 3 and the maximum recombination frequency to 30%. The Kosambi function was used to calculate the genetic distance (cM). The two genetics maps, one for each population, are shown in Fig. 2. In summary, 22 TSM markers could be integrated into a genetic map of 1RS, 16 in the Sp3 x Hy2 map, and 11 in the Sp4 x Hy2 map. Five markers were mapped in both populations. Furthermore, we integrated the physical map into the genetic maps. As only a few of the markers from the genetic maps could also be physically mapped using the deletion lines developed by Tsuchida et al. (2008), we used the physical mapping results reported by Kofler et al. (under review) instead. The results of the genetic mapping are supported by the physical map, as markers of different bins map to distinct areas in the genetic maps (Fig. 2). Only results for the markers Xtsm279-1R and Xtsm592.2 are conflicting (Fig. 2).

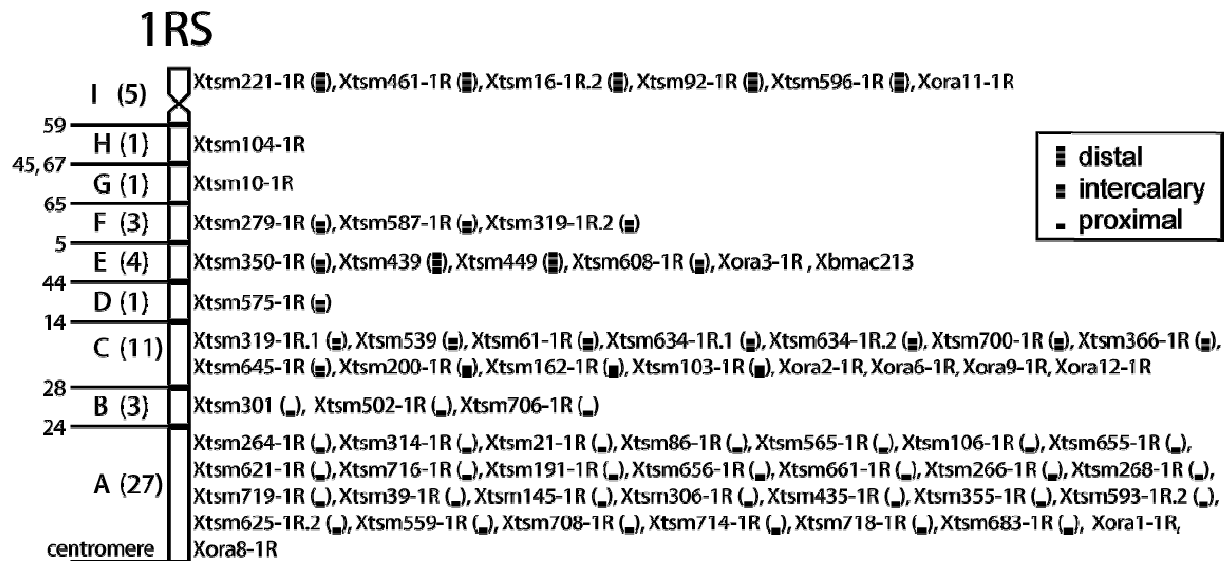

**Fig. 1:** Physical (bin) map of the 1RS arm; 56 TSM markers and 9 previously published PCR based markers have been integrated. The figures on the left-hand side indicate the breakpoints of the deletion lines and the resulting bins. The numbers in brackets represent the number of TSM markers mapping to a certain bin. Individual markers are shown on the right-hand side, the symbols in brackets indicating the physical positions as reported by Kofler et al. (in press).

## METHODS

DNA was extracted from the leaves of the plant material using the CTAB-method.

All primer pairs were tested with fluorescence labeled M13-oligos according to Schülke (2000). Three different 'Touchdown' PCR programs were used and PCR products were run on a 12% polyacrylamid gel. All gels were scanned with the Typhoon Trio (GE Healthcare) variable mode imager.

## REFERENCES

- Friebe B, Kynast R G, & Gill B S (2000), Gametocidal factor-induced structural rearrangements in rye chromosomes added to common wheat. *Chromosomes Res.* 8(6): 501-11
- Schülke M (2000), An economic method for the fluorescent labelling of PCR fragments. *Nat. Biotechnol.* 18(2): 233-4
- Hackauf B & Wehling P (2003), Development of microsatellite markers in rye: map construction. *Plant Breeding and Seed Science* 48: 143-51
- Koebner R M D (1995), Generation of PCR-based markers for the detection of rye chromatin in a wheat background. *Theor. Appl. Genet.* 90: 740-45

Ramsay L, Macaulay M, Ivanissevich S, MacLean K, Cardle L, Fuller J, Edwards K J, Tuvevsson S, Morgante M, Massari A, Maestri E, Marmioli N, Sjakste T, Ganai M, Powell W, Waugh R (2000), A simple sequence repeat-based linkage map of barley. *Genetics* 156: 1997-2005

Tsuchida M, Fukushima T, Nasuda S, Masoudi-Nejad A, Ishikawa G, Nakamura T, Endo TR (2008), Dissection of rye chromosome 1R in common wheat. *Genes Genet. Syst.* 83: 43-53

## ACKNOWLEDGEMENTS

This work was financially supported by the Austrian Science Fund (FWF, No P18414-B14)

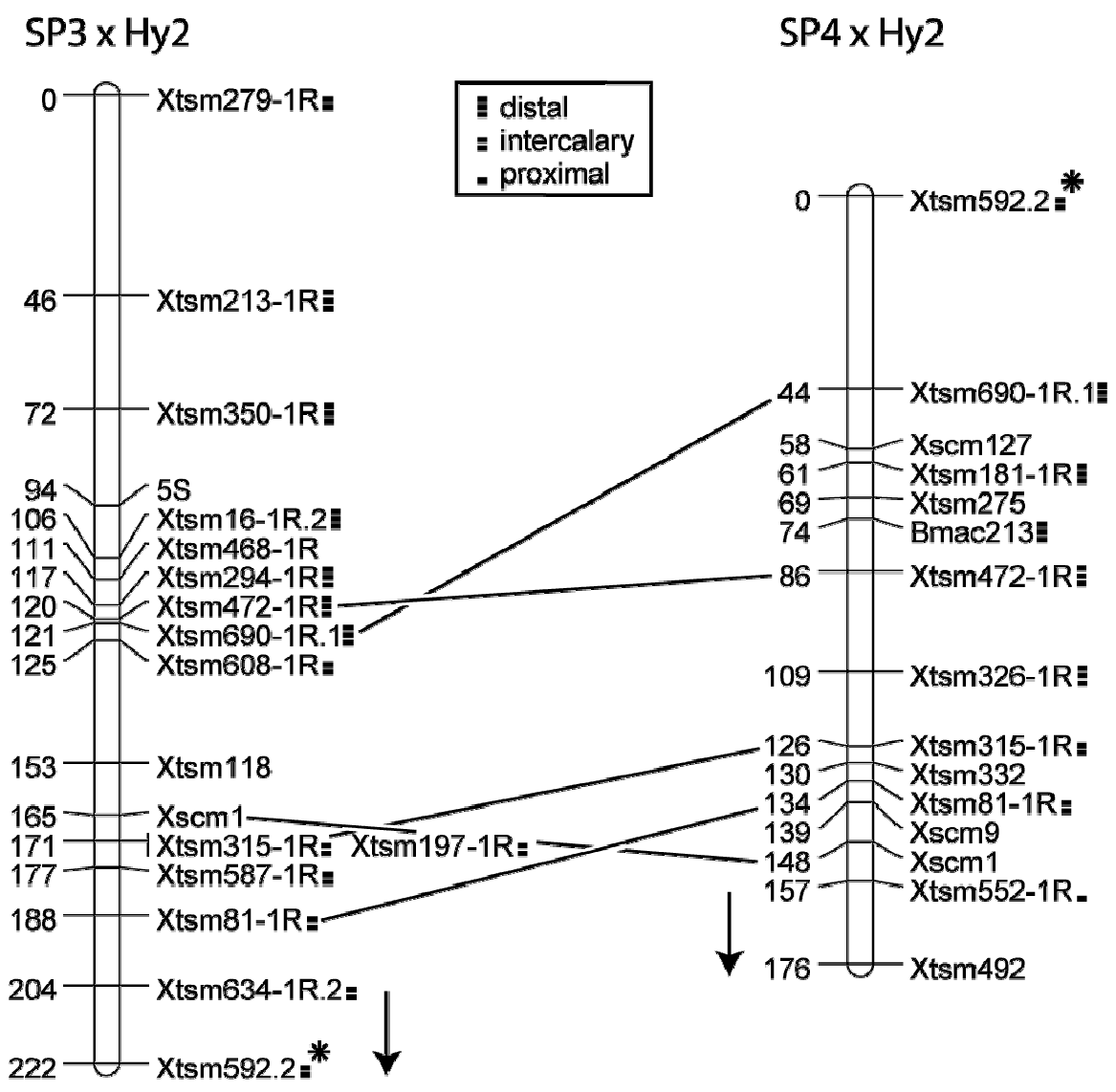

**Fig. 2:** An SSR-based genetic map of 1RS, encompassing 27 distinct loci. Genetic distances (cM) are indicated on the left-hand side and locus names on the right-hand side, for each mapping population. Solid lines link identical loci on the two populations. Putative positions of the centromeres are indicated by black arrows. Symbols in brackets represent the physical position according to Kofler et al. (in press).