

**Reconsidering Late Roman Cyprus:
Using new material from Nea Paphos to review
current artefact typologies**

**Figures, Plates &
Inventory Database (Appendix 1)**

Andrea H. Rowe

A thesis submitted in fulfilment of the
requirements for the degree of
Doctor of Philosophy

Department of Classical Archaeology

University of Sydney

2004

Table of Contents

| | |
|---|-----|
| 1. LIST OF FIGURES..... | 1 |
| 2. LIST OF PLATES | 5 |
| 3. FIGURES | 6 |
| 4. PLATES | 158 |
| 5. APPENDIX 1: INVENTORY DATABASE | 174 |

1. List of Figures

| | | |
|-----------|---|----|
| Figure 1 | Location map of the Kornos Cave, Cyprus (Source; Catling & Dikigoropoulos. 1970) | 6 |
| Figure 2 | Sketch plan of the Kornos Cave and pottery finds (Source; Catling & Dikigoropoulos. 1970) | 7 |
| Figure 3 | Section drawing from Salamis Bath building (Source; Catling & Dikigoropoulos. 1970) | 8 |
| Figure 4 | Pottery finds from the Salamis bench deposit (Source; Catling & Dikigoropoulos. 1970) | 9 |
| Figure 5 | Location map of the Dhiorios kiln site, Cyprus (Source; Catling 1972)..... | 10 |
| Figure 6 | Plan of excavated parts of Dhiorios site (Source; Catling 1972) | 11 |
| Figure 7 | Section drawings from Kilns at Dhiorios (Source; Catling 1972) | 12 |
| Figure 8 | Map of Cyprus | 13 |
| Figure 9 | Sketch plan of Nea Paphos..... | 14 |
| Figure 10 | Map of Mediterranean..... | 15 |
| Figure 11 | Map of Egypt (Adapted from Egloff, 1977) | 16 |
| Figure 12 | Map of Ancient Alexandria..... | 17 |
| Figure 13 | Plan of Paphos Hellenistic Theatre excavations | 18 |
| Figure 14 | Plan of Paphos Theatre and environs | 19 |
| Figure 15 | Sample of Deposit Field Record sheet..... | 20 |
| Figure 16 | Sample of Sherd Count sheet and Main Inventory form..... | 21 |
| Figure 17 | Sample of Diagnostic sherd form and Inventory Database form | 22 |
| Figure 18 | Plan of trenches 3A and 3B..... | 23 |
| Figure 19 | Plan of early street? level in 3A | 24 |
| Figure 20 | Plan of paved street in 3A and 3B..... | 25 |
| Figure 21 | Section drawings from 3A | 26 |
| Figure 22 | Cypriot Hellenistic Colour-Coated ware. Scale 1:2..... | 27 |
| Figure 23 | Typological developments from Cypriot Sigillata to Cypriot Red Slip ware (Source; Meyza, 1995)..... | 28 |
| Figure 24 | Cypriot Sigillata dishes and bowls. Scale 1:2 | 29 |
| Figure 25 | Cypriot Sigillata bowls. Scale 1:2..... | 30 |
| Figure 26 | Cypriot Sigillata kraters. Scale 1:2 | 31 |
| Figure 27 | Cypriot Red Slip ware typology from Kôm el-Dikka (Source; Rodziewicz 1976) | 32 |
| Figure 28 | Cypriot Red Slip ware typology from Kôm el-Dikka (Source; Rodziewicz 1976) | 33 |
| Figure 29 | Cypriot Red Slip ware Form 1 | 34 |
| Figure 30 | Revised typology for Cypriot Red Slip ware Part 1 (Source; Meyza, 2000) | 35 |
| Figure 31 | Cypriot Red Slip ware Form 1. Scale 1:2 | 36 |
| Figure 32 | Cypriot Red Slip ware Forms 1 & 2. Scale 1:2..... | 37 |

| | | |
|-----------|---|----|
| Figure 33 | Cypriot Red Slip ware Forms 3, 5 & 7. Scale 1:2..... | 38 |
| Figure 34 | Revised typology for Cypriot Red Slip ware Part 2 (Source; Meyza, 2000).... | 39 |
| Figure 35 | Cypriot Red Slip ware Form 8. Scale 1:2 | 40 |
| Figure 36 | Cypriot Red Slip ware Form 8. Scale 1:2 | 41 |
| Figure 37 | African Red Slip ware forms similar to CRSW Form 8 | 42 |
| Figure 38 | Cypriot Red Slip ware Form K1? from other sites | 43 |
| Figure 39 | Cypriot Red Slip ware Form K1. Scale 1:2..... | 44 |
| Figure 40 | Revised typology for Cypriot Red Slip ware Part 3 (Source; Meyza, 2000).... | 45 |
| Figure 41 | Cypriot Red Slip ware Forms 9var and 9A. Scale 1:2 | 46 |
| Figure 42 | Cypriot Red Slip ware Form 9A. Scale 1:2..... | 47 |
| Figure 43 | Cypriot Red Slip ware Form 9B. Scale 1:2..... | 48 |
| Figure 44 | Cypriot Red Slip ware Form 9B. Scale 1:2..... | 49 |
| Figure 45 | Cypriot Red Slip ware Form 9C. | 50 |
| Figure 46 | Cypriot Red Slip ware Form 10. Scale 1:2 | 51 |
| Figure 47 | Revised typology for Cypriot Red Slip ware Part 4 (Source; Meyza, 2000).... | 52 |
| Figure 48 | Cypriot Red Slip ware Form 11. Scale 1:2 | 53 |
| Figure 49 | Cypriot Red Slip ware Form 11. Scale 1:2 | 54 |
| Figure 50 | Black-glaze ware. Scale 1:2..... | 55 |
| Figure 51 | Eastern Sigillata A and Terra Sigillata. Scale 1:2..... | 56 |
| Figure 52 | Thin-walled ware. Scale 1:2..... | 57 |
| Figure 53 | African Red Slip ware. Scale 1:2..... | 58 |
| Figure 54 | “Phocaeen” Red Slip ware. Scale 1:2 | 59 |
| Figure 55 | “Phocaeen” Red Slip ware. Scale 1:2 | 60 |
| Figure 56 | Egyptian Red Slip A ware. Scale 1:2..... | 61 |
| Figure 57 | Egyptian Red Slip B ware. Scale 1:2 | 62 |
| Figure 58 | Egyptian Red Slip B ware. Scale 1:2..... | 63 |
| Figure 59 | Egyptian Red Slip C ware. Scale 1:2..... | 64 |
| Figure 60 | Egyptian Red Slip C ware. Scale 1:2..... | 65 |
| Figure 61 | Egyptian Painted Basins. Scale 1:2..... | 66 |
| Figure 62 | Egyptian Painted Jugs/Flagons. Scale 1:2..... | 67 |
| Figure 63 | “Decorated Red ware”. Scale 1:2..... | 68 |
| Figure 64 | “Decorated Red ware”. Scale 1:2..... | 69 |
| Figure 65 | Early Roman Cooking Pots Type 1. Scale 1:2..... | 70 |
| Figure 66 | Early Roman Cooking Pots Type 2. Scale 1:2..... | 71 |
| Figure 67 | Early Roman Cooking Pots Type 3. Scale 1:2..... | 72 |
| Figure 68 | Fourth century Cooking Pots Type 1. Scale 1:2 | 73 |
| Figure 69 | Fourth century Cooking Pots Type 1. Scale 1:2 | 74 |
| Figure 70 | Fourth century Cooking Pots Type 2. Scale 1:2 | 75 |
| Figure 71 | Fourth century Cooking Pots Type 3. Scale 1:2 | 76 |
| Figure 72 | Fifth century and later Cooking pot types. Scale 1:2 | 77 |
| Figure 73 | Imported Cooking pot types. Scale 1:2..... | 78 |
| Figure 74 | Early to Mid Roman Casserole types. Scale 1:2..... | 79 |

| | | |
|------------|--|-----|
| Figure 75 | Fourth century Casserole types. Scale 1:2 | 80 |
| Figure 76 | Fifth century Casserole types. Scale 1:2 | 81 |
| Figure 77 | Cooking ware Lids. Scale 1:2 | 82 |
| Figure 78 | Cooking ware Frying pans. Scale 1:2 | 83 |
| Figure 79 | Cooking ware Bowls. Scale 1:2 | 84 |
| Figure 80 | Cooking ware Bowls & Imported bowls. Scale 1:2..... | 85 |
| Figure 81 | Imported Cooking ware bowls. Scale 1:2 | 86 |
| Figure 82 | Cooking ware Jugs/Jars. Scale 1:2..... | 87 |
| Figure 83 | Cooking Pots from Jalame (left) and Dhiorios (right). Scale 1:4..... | 88 |
| Figure 84 | Plain ware Bowls. Scale 1:2..... | 89 |
| Figure 85 | Plain ware Bowls. Scale 1:2..... | 90 |
| Figure 86 | Plain ware Basins. Scale 1:2 | 91 |
| Figure 87 | Plain ware Basins. Scale 1:2 | 92 |
| Figure 88 | Plain ware Pithoi and Lids. Scale 1:2 | 93 |
| Figure 89 | Plain ware Jugs. Scale 1:2..... | 94 |
| Figure 90 | Plain ware Jugs. Scale 1:2..... | 95 |
| Figure 91 | Plain ware Jars. Scale 1:2..... | 96 |
| Figure 92 | Plain ware Jars and Cups/Beakers. Scale 1:2..... | 97 |
| Figure 93 | Early Roman Amphorae. Scale 1:2..... | 98 |
| Figure 94 | Mid Roman 4 Amphorae. Scale 1:2..... | 99 |
| Figure 95 | Mid Roman 4 Amphorae. Scale 1:2..... | 100 |
| Figure 96 | Mid Roman 4 Amphorae. Scale 1:2..... | 101 |
| Figure 97 | Mid Roman Amphorae. Scale 1:2..... | 102 |
| Figure 98 | Mid Roman Amphorae. Scale 1:2..... | 103 |
| Figure 99 | Mid Roman/Late Roman Amphorae. Scale 1:2 | 104 |
| Figure 100 | Mid Roman/Late Roman Amphorae. Scale 1:2 | 105 |
| Figure 101 | Mid Roman/Late Roman Amphorae. Scale 1:2 | 106 |
| Figure 102 | Late Roman 1 Amphorae. Scale 1:2 | 107 |
| Figure 103 | Late Roman 1 Amphorae. Scale 1:2 | 108 |
| Figure 104 | Late Roman 1 Amphorae. Scale 1:2 | 109 |
| Figure 105 | Late Roman 1 Amphorae. Scale 1:2 | 110 |
| Figure 106 | Late Roman 1 Amphora. Scale 1:2..... | 111 |
| Figure 107 | Late Roman 2 Amphorae. Scale 1:2 | 112 |
| Figure 108 | Late Roman 4 Amphorae. Scale 1:2 | 113 |
| Figure 109 | Late Roman 4 Amphorae. Scale 1:2 | 114 |
| Figure 110 | Late Roman 4 Amphorae. Scale 1:2 | 115 |
| Figure 111 | Late Roman 7 Amphorae. Scale 1:2 | 116 |
| Figure 112 | Late Roman 7 Amphora. Scale 1:2..... | 117 |
| Figure 113 | Late Roman 8 & 5/6 Amphorae. Scale 1:2 | 118 |
| Figure 114 | Late Roman 1 & 4 Amphorae from Kalavasos-Kopetra and the Garrison's Camp..... | 119 |
| Figure 115 | Group 1 Roman Lamps. Scale 1:2 | 120 |

| | | |
|------------|--|-----|
| Figure 116 | Group 2 Roman Lamps. Scale 1:2 | 121 |
| Figure 117 | Group 2 Roman Lamps. Scale 1:2 | 122 |
| Figure 118 | Group 3 Roman Lamps. Scale 1:2 | 123 |
| Figure 119 | Group 3 Roman Lamps. Scale 1:2 | 124 |
| Figure 120 | Group 4 Roman Lamps. Scale 1:2 | 125 |
| Figure 121 | Group 4 Roman Lamps..... | 126 |
| Figure 122 | Group 4 Roman Lamps. Scale 1:2 | 127 |
| Figure 123 | Group 5 Roman Lamps. Scale 1:2 | 128 |
| Figure 124 | Metal Small Finds. Scale 1:1 | 129 |
| Figure 125 | Inv.279 and Inv.488 | 130 |
| Figure 126 | Stone Basins..... | 131 |
| Figure 127 | Inv.494 and spindle whorls | 132 |
| Figure 128 | Terracotta Small Finds and Inv.199. Scale 1:1 | 133 |
| Figure 129 | Glass Deep Bowls Scale 1:2 | 134 |
| Figure 130 | Glass Deep Bowls. Scale 1:4 | 135 |
| Figure 131 | Glass Deep Bowls. Scale 1:2 | 136 |
| Figure 132 | Glass Deep Bowls. Scale 1:4 | 137 |
| Figure 133 | Glass Shallow Bowls. Scale 1:2..... | 138 |
| Figure 134 | Glass Shallow Bowls and Plates. Scale 1:4 | 139 |
| Figure 135 | Glass Plates. Scale 1:2 | 140 |
| Figure 136 | Glass Beakers. Scale 1:2 | 141 |
| Figure 137 | Glass Beakers. Scale 1:4 | 142 |
| Figure 138 | Glass Beaker bases. Scale 1:2..... | 143 |
| Figure 139 | Glass Flasks. Scale 1:2..... | 144 |
| Figure 140 | Glass Flasks. Scale 1:4..... | 145 |
| Figure 141 | Glass Flasks with spiral trail decoration. Scale 1:2..... | 146 |
| Figure 142 | Glass Flasks with spiral trail decoration | 147 |
| Figure 143 | Glass Stemmed Drinking Cups and Bottles. Scale 1:2 | 148 |
| Figure 144 | Glass Stemmed Drinking Cups. Scale 1:4 | 149 |
| Figure 145 | Glass Lids and Unguentarium. Scale 1:2 | 150 |
| Figure 146 | Glass Lids, Unguentarium and Lamps. Scale 1:4 | 151 |
| Figure 147 | Glass Lamps Scale. 1:2 | 152 |
| Figure 148 | Glass Jugs. Scale 1:2..... | 153 |
| Figure 149 | Glass Jugs. Scale 1:4..... | 154 |
| Figure 150 | Glass Miscellaneous handles and decoration. Scale 1:2 | 155 |
| Figure 151 | Glass typology and chronology for Jordan and Southern Syria (Source, Dussart, 1995)..... | 156 |
| Figure 152 | Glass typology for Jordan and Southern Syria (Source, Dussart, 1995)..... | 157 |

2. List of Plates

| | | |
|----------|---|-----|
| Plate 1 | View of Area Three looking Southeast..... | 158 |
| Plate 2 | Trenches 3A, 3B and 3C..... | 159 |
| Plate 3 | Trench 3A showing paved street with toilet hole to drain, looking south | 159 |
| Plate 4 | Early street level? in 3A with covered N/S drain, looking north | 160 |
| Plate 5 | Lowest level in 3A with bedrock and drainage system, looking north..... | 161 |
| Plate 6 | East Section of trench 3A..... | 162 |
| Plate 7 | South Section of trench 3A | 162 |
| Plate 8 | Trench 3B excavated to bedrock, with drainage outlet in south baulk | 163 |
| Plate 9 | West Section of trench 3B | 164 |
| Plate 10 | Trench 3B showing S/N side drain running into the main E/W drain | 164 |
| Plate 11 | West Section of trench 3C | 165 |
| Plate 12 | Trench 3C excavated to bedrock, looking south..... | 165 |
| Plate 13 | Inv.423 (top), Inv.354 (bottom), Inv.808 (right)..... | 166 |
| Plate 14 | Inv.407 (top left), Inv.7572 (top right), Inv.7581 (centre left), Inv.7580 (centre), Inv.7542 (centre right), Inv.420 (bottom)..... | 166 |
| Plate 15 | Inv.500, front | 167 |
| Plate 16 | Inv.500, back..... | 167 |
| Plate 17 | Inv.327 | 168 |
| Plate 18 | Inv.1179 (top), Inv.936 (bottom left), Inv.938 (bottom right) | 168 |
| Plate 19 | Inv.279 (top), Inv.302, 303 & 502 (bottom) | 168 |
| Plate 20 | Inv.511 (left), Inv.311 (top right), Inv.512 (bottom right)..... | 169 |
| Plate 21 | Inv.495 (top), Inv.494 (bottom) | 169 |
| Plate 22 | Inv.331 (left), Inv.436 (right)..... | 170 |
| Plate 23 | Inv.199 (side view) | 170 |
| Plate 24 | Inv.199 (top view)..... | 171 |
| Plate 25 | Glass flasks with spiral trail decoration | 171 |
| Plate 26 | Glass decorative band from flask, Inv.692/704 | 172 |
| Plate 27 | Glass Lamp bases..... | 172 |
| Plate 28 | Glass Drinking Cup stemmed base, Inv.643 (top), Base for flask, Inv.636 (centre), glass lid, Inv.622 (bottom)..... | 173 |
| Plate 29 | Glass jug base, Inv.696 | 173 |

All ink drawings of Inventory objects from the Area Three assemblage are presented at a scale of 1:2, unless marked specifically otherwise next to the item. Drawings from other sources have the scale marked next to the item. If no scale is shown then it was not indicated on the original.

3. Figures

THE LAPETHUS AREA IN THE EARLY BYZANTINE PERIOD

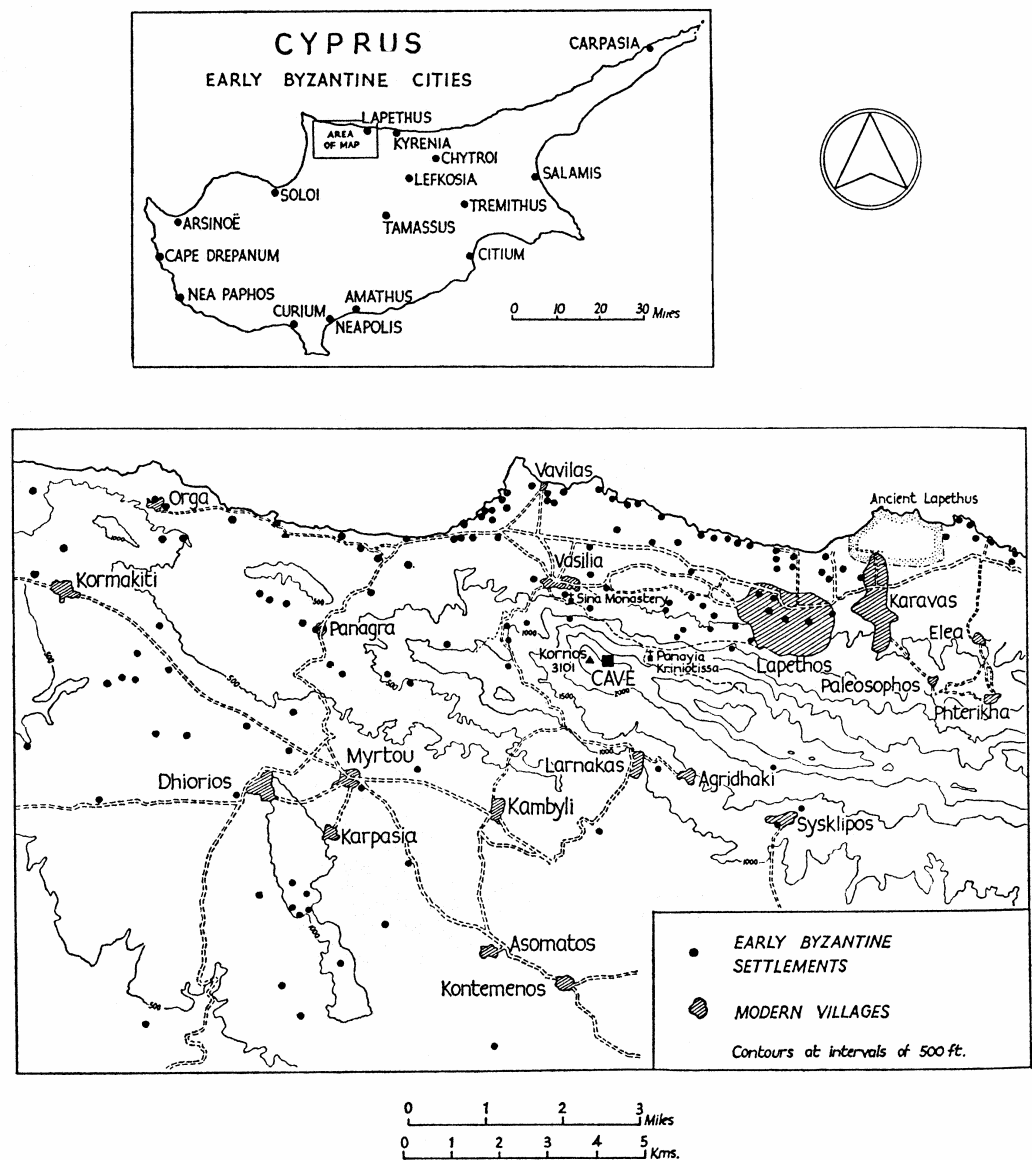
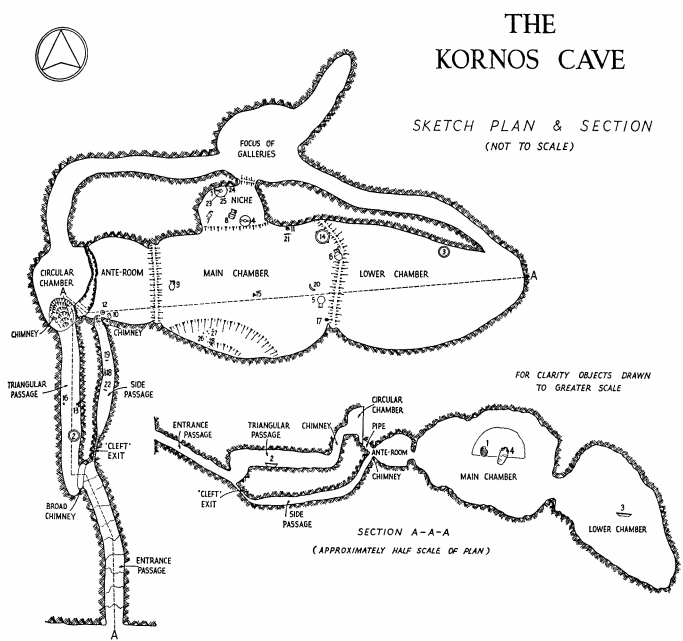
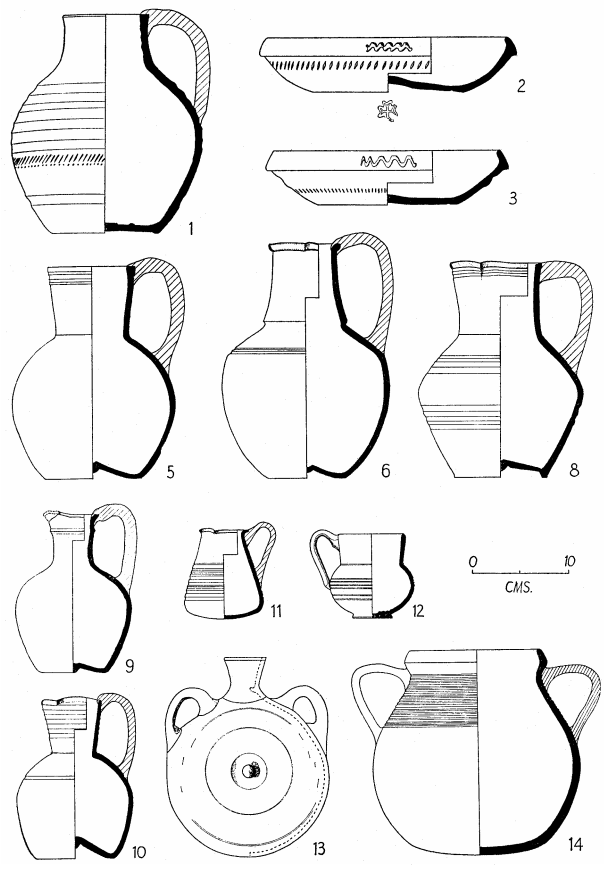

Figure 1 Location map of the Kornos Cave, Cyprus (Source; Catling & Dikigoropoulos. 1970)



1



2

Figure 2 Sketch plan of the Kornos Cave and pottery finds (Source; Catling & Dikigoropoulos. 1970)

SALAMIS BATH BUILDING

SECTION THROUGH WEST PORTICO
(30 Mrs. from SW. Corner)

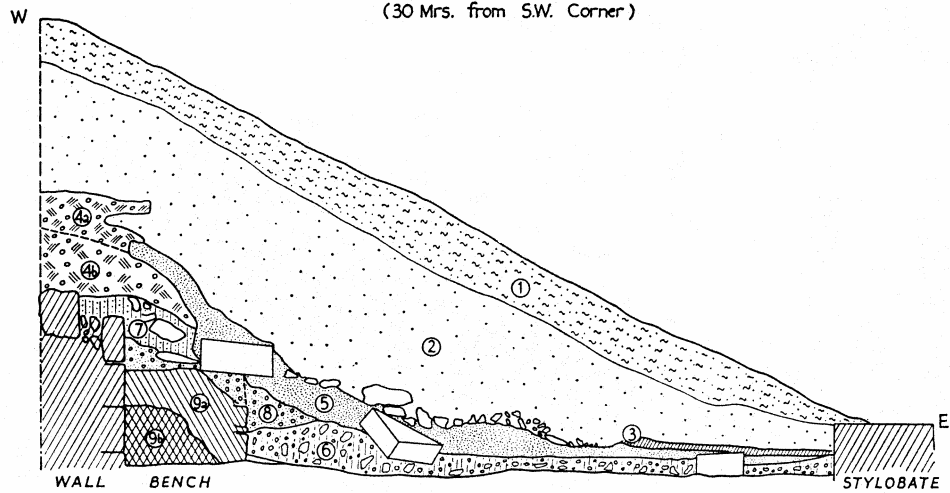

- | | |
|------------------------------------|---------------------------------|
| ① Top sand | ⑥ Loose earth & building débris |
| ② Loose sand | ⑦ Loose brown gritty soil |
| ③ Skin of earth | ⑧ Hard gritty pink ?pisé |
| ④ Hard grey earth & plaster frags. | ⑨ Outer structure of bench |
| ⑤ Hardened sand | ⑩ Hard core of bench |

0 1 2 3 4 5 6 7 8 9 10 Ft.
0 1 2 3 Mrs.

Figure 3 Section drawing from Salamis Bath building (Source; Catling & Dikigoropoulos. 1970)

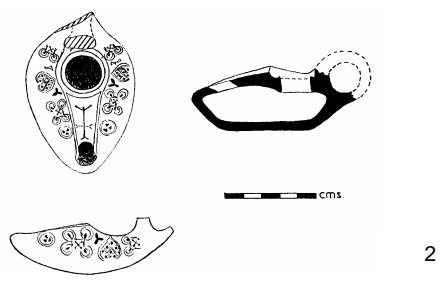
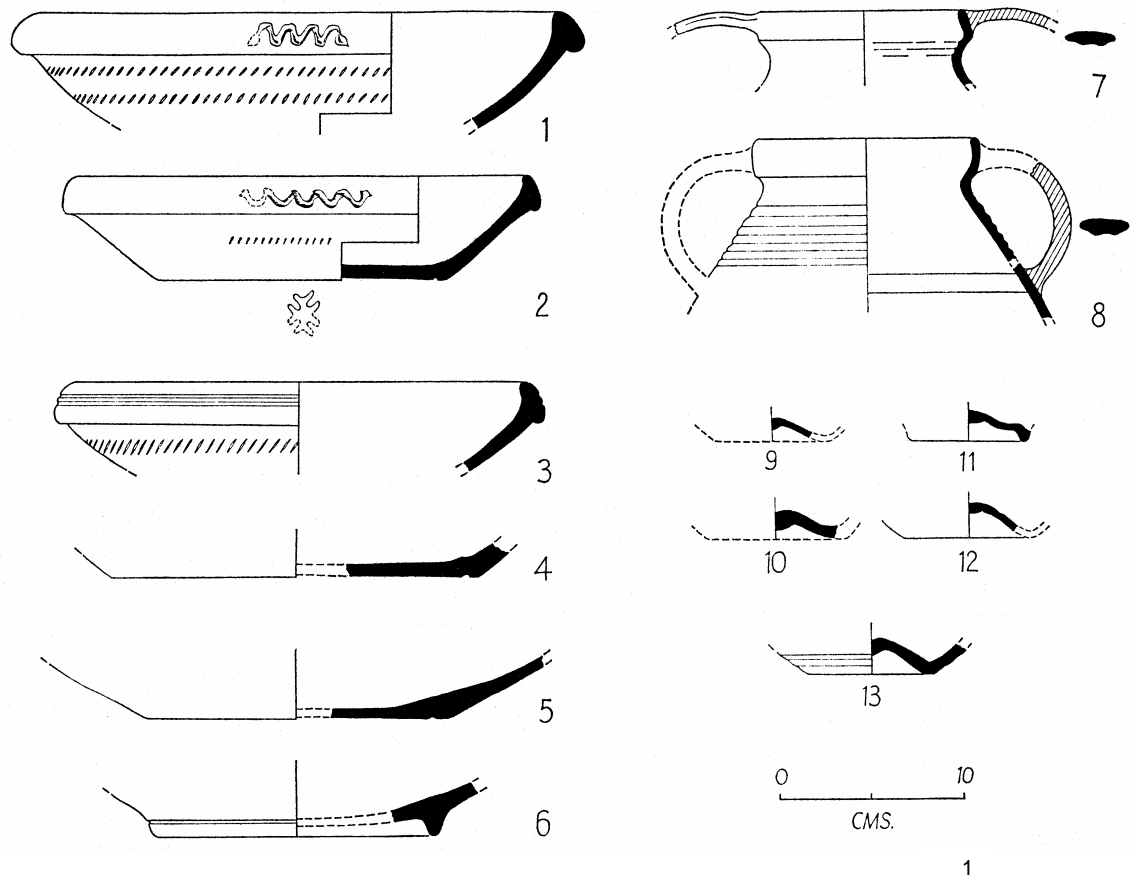
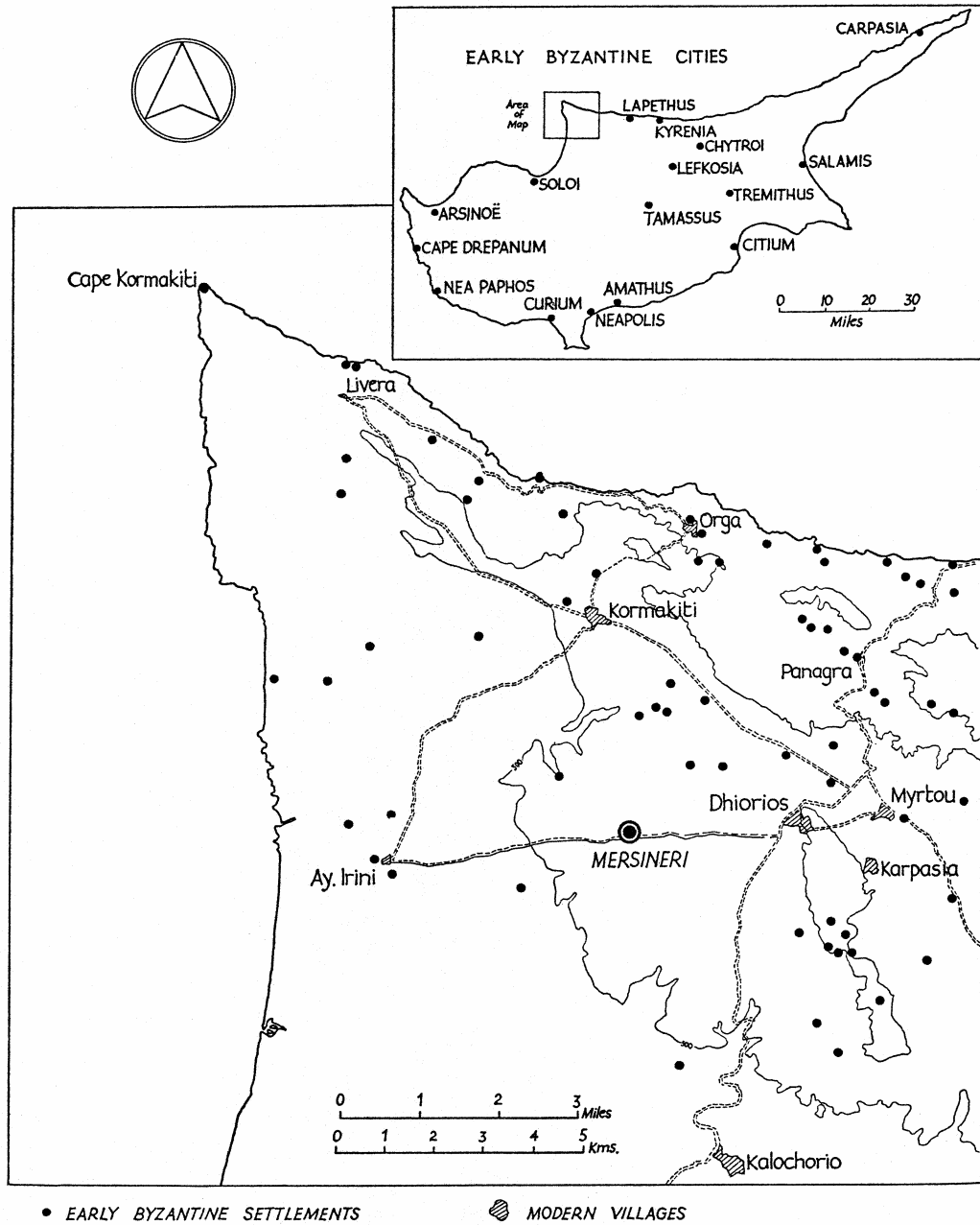

Figure 4 Pottery finds from the Salamis bench deposit (Source; Catling & Dikigoropoulos. 1970)

THE CAPE KORMAKITI AREA IN THE EARLY BYZANTINE PERIOD



• EARLY BYZANTINE SETTLEMENTS ◉ MODERN VILLAGES

Figure 5 Location map of the Dhiorios kiln site, Cyprus (Source; Catling 1972)

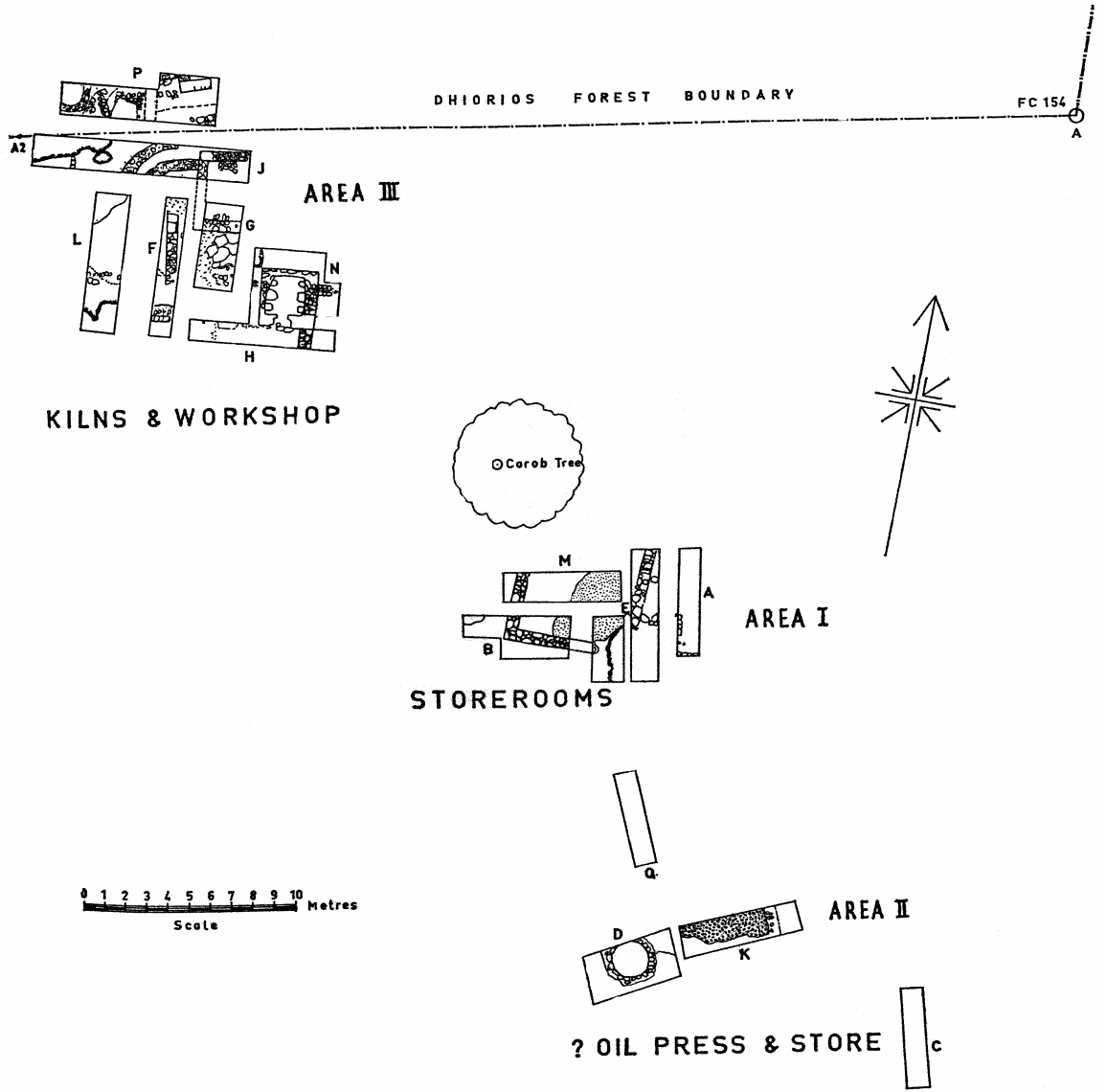

Figure 6 Plan of excavated parts of Dhiorios site (Source; Catling 1972)

KILNS

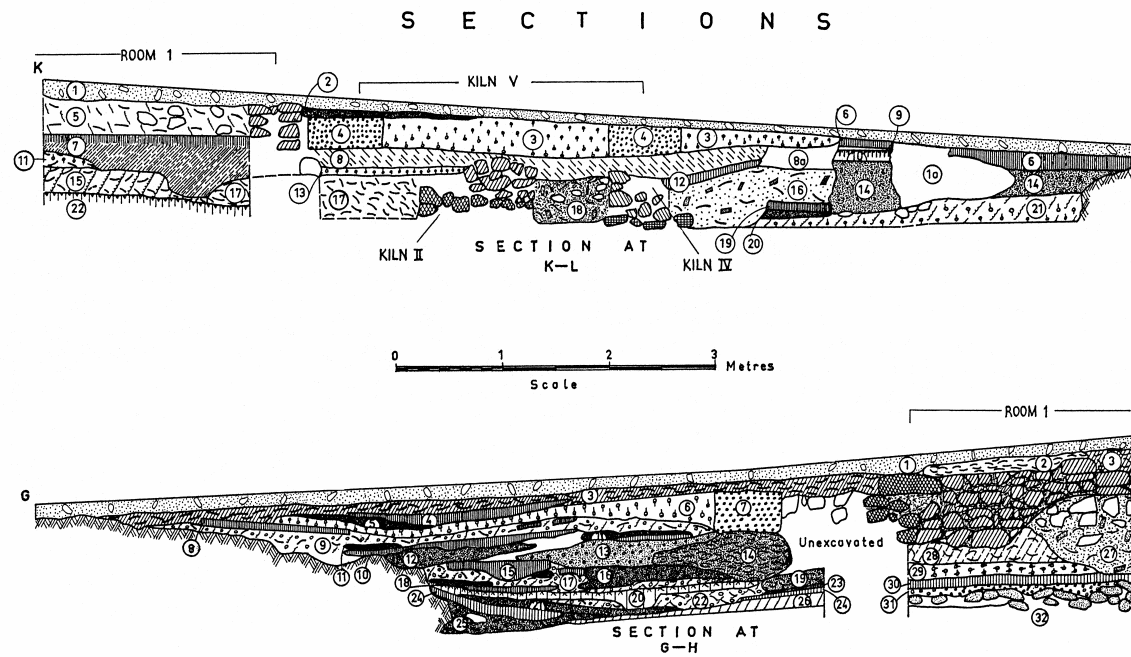

Figure 7 Section drawings from Kilns at Dhiorios (Source; Catling 1972)

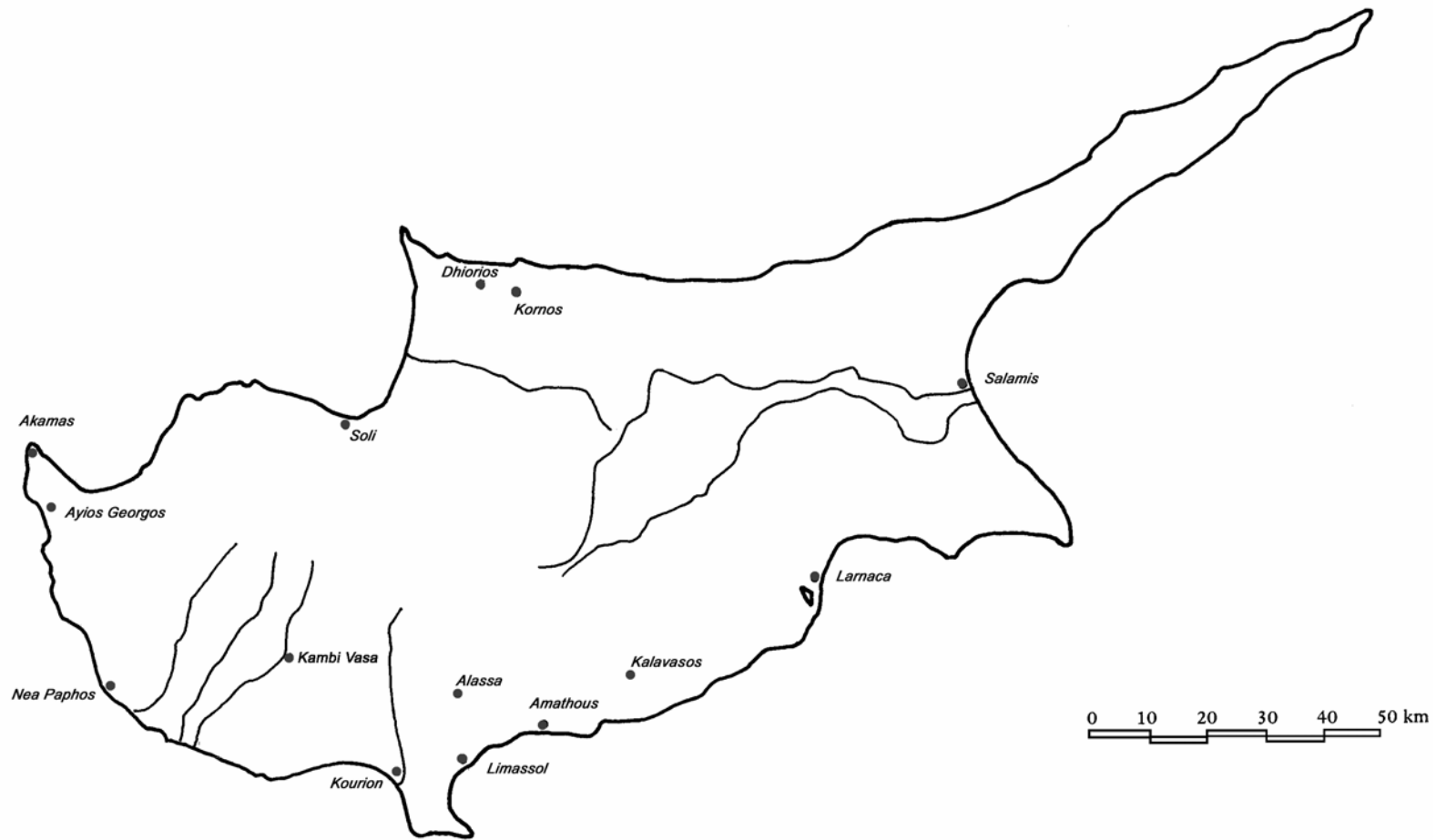

Figure 8 Map of Cyprus

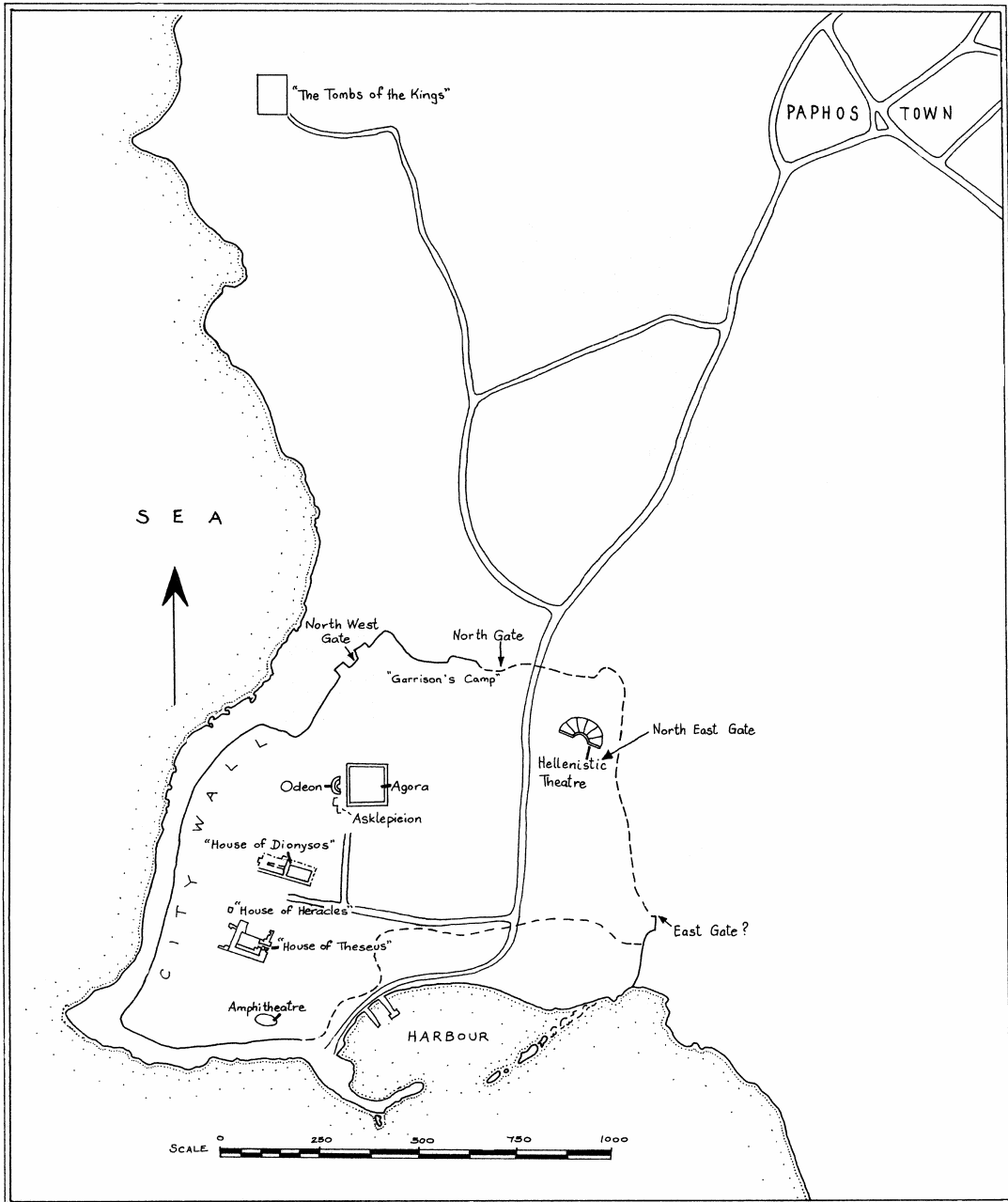

Figure 9 Sketch plan of Nea Paphos

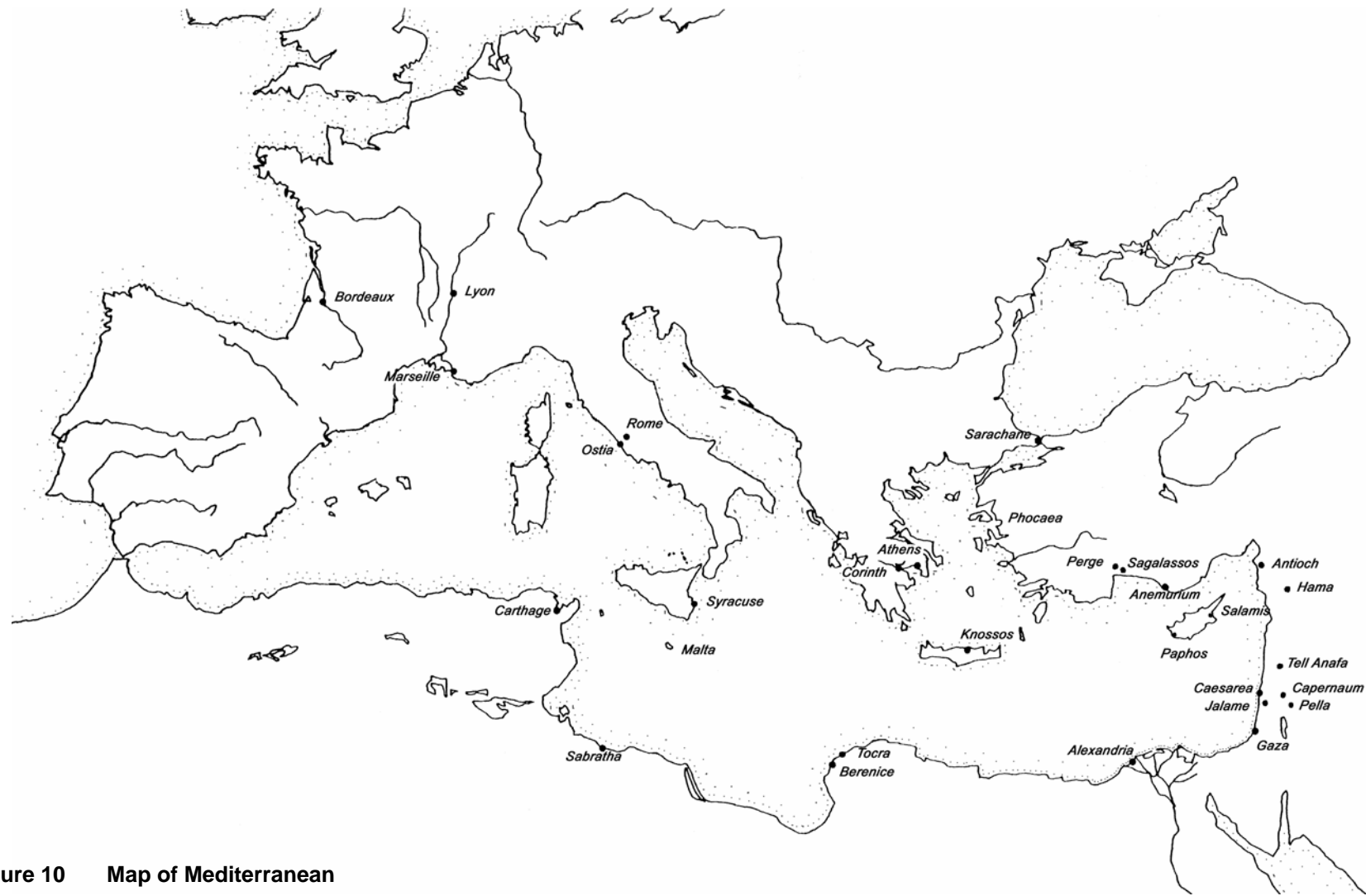

Figure 10 Map of Mediterranean

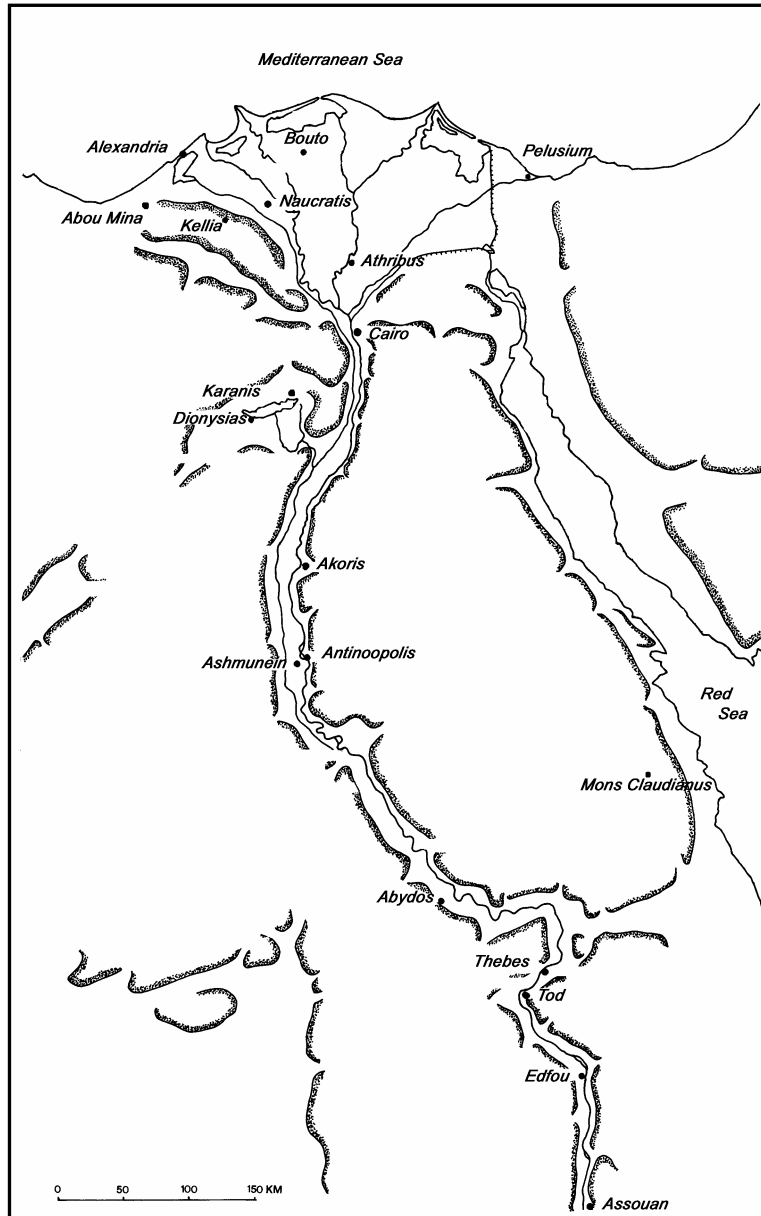

Figure 11 Map of Egypt (Adapted from Egloff, 1977)

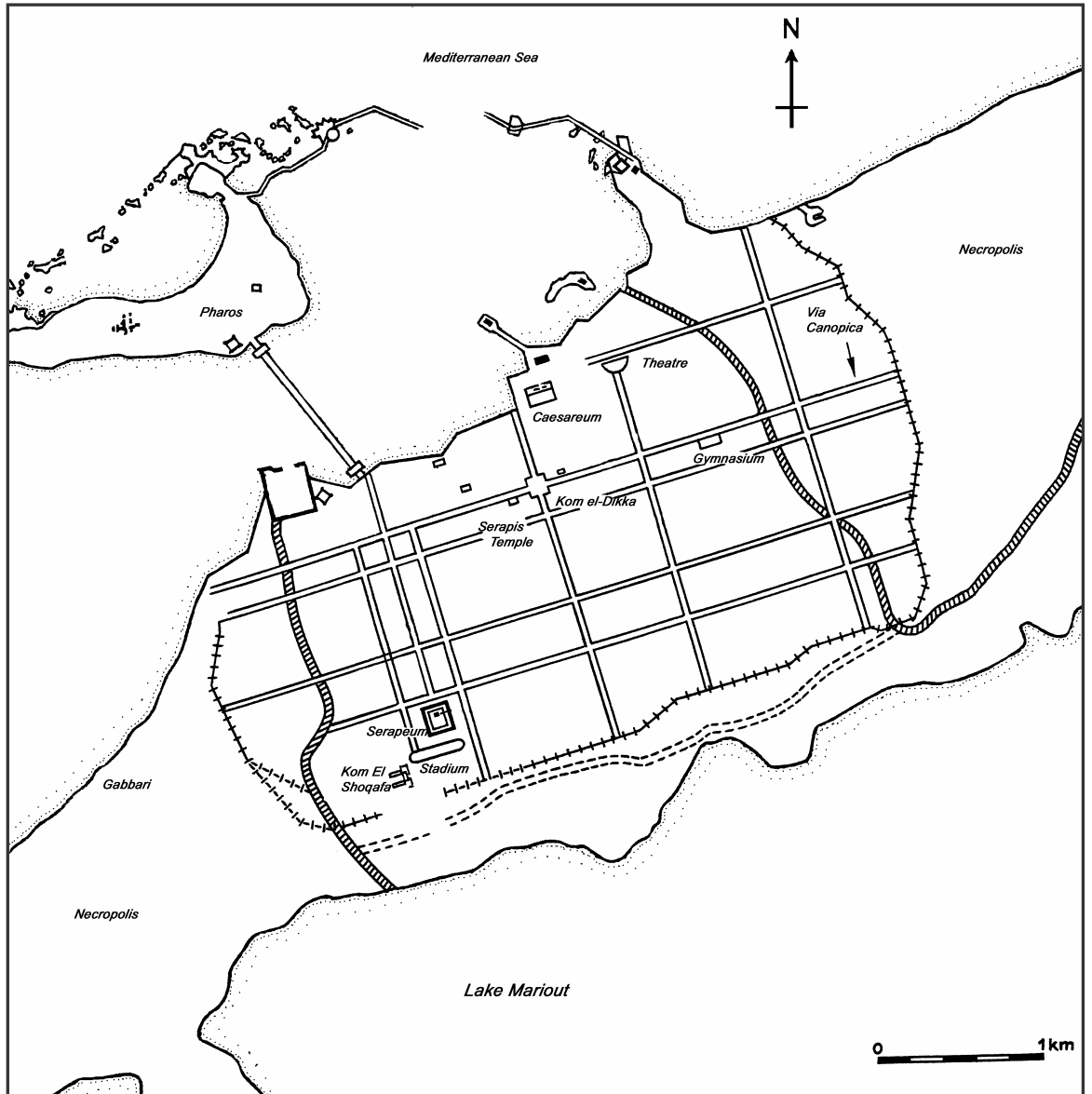

Figure 12 Map of Ancient Alexandria

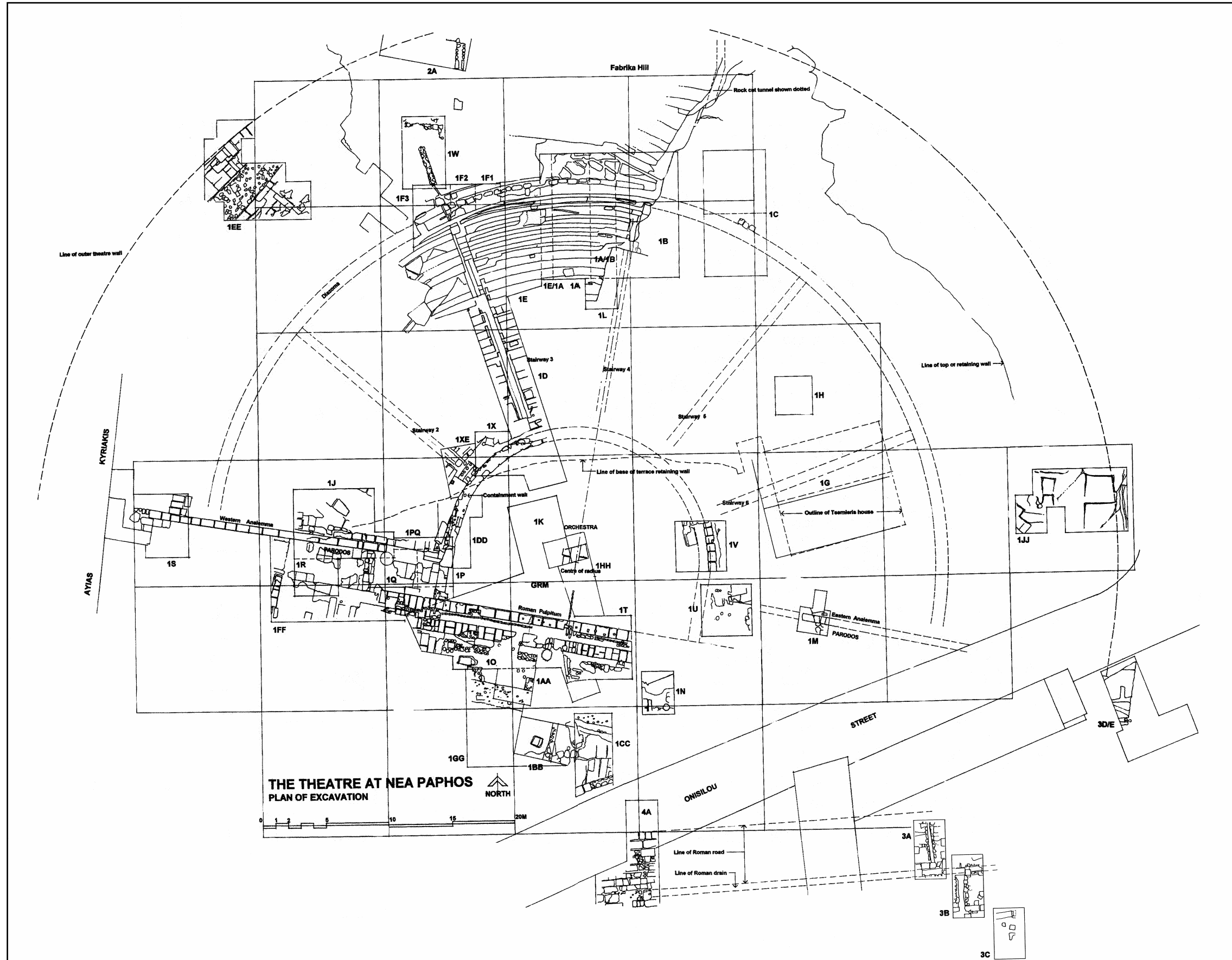

Figure 13 Plan of Paphos Hellenistic Theatre excavations

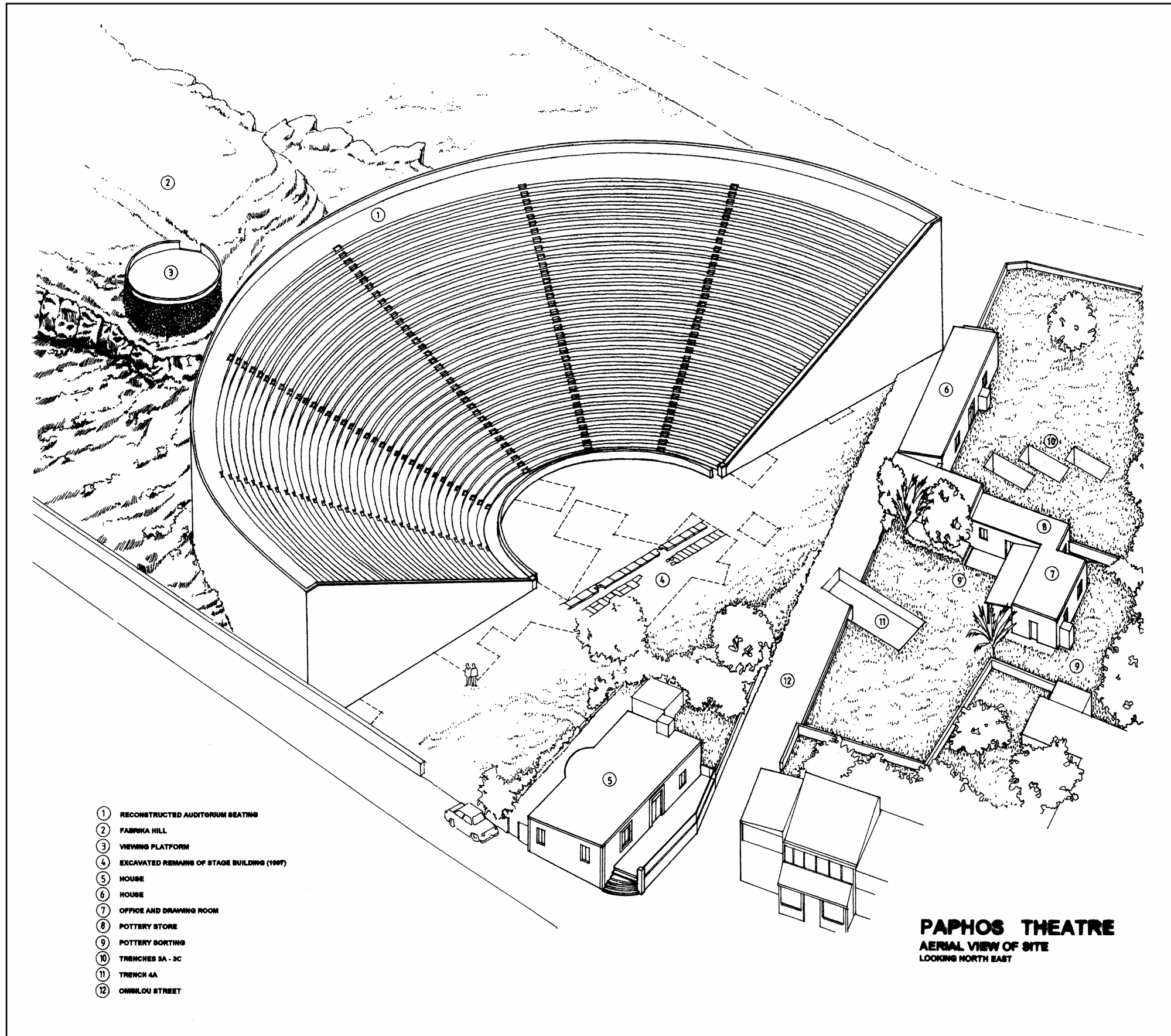

Figure 14 Plan of Paphos Theatre and environs

PAPHOS THEATRE EXCAVATIONS – 1999
DEPOSIT FIELD RECORD

EXCAVATOR: _____ DATE: ____ / ____ / 1999
LOG BOOK PAGE: _____

DEPOSIT _____ TRENCH _____
ROOM _____

NO. OF CELLS

INTEGRITY undisturbed - disturbed DISCARD Primary - secondary

STRUCTURE fill - floor makeup - occupation floor - wall - pit - burial

DEFINITION & BOUNDARIES arbitrary / natural

COLOUR Munsell ____ / ____ / ____

TEXTURE VOLUME

STRATIGRAPHIC RELATIONSHIPS

Underlies Cut by
Equals abuts
Overlies cuts

LEVELS

| | before excavation | | after excavation | |
|---|-------------------|---------|------------------|-----------------|
| | datum | reading | reduced | reading reduced |
| A | _____ | _____ | _____ | _____ |
| B | _____ | _____ | _____ | _____ |
| C | _____ | _____ | _____ | _____ |
| D | _____ | _____ | _____ | _____ |

Sketch plan scale _____
Refer to measured plan

Refer to section

EXCAVATION TECHNIQUE

SIEVE coarse / fine /

FINDS pottery stone bone metal coin organic other

SAMPLES C14

Flotation Soil Other

PHOTOGRAPHIC

| Neg number | Facing | Subject |
|------------|--------|---------|
| | | |
| | | |
| | | |
| | | |

EXTRA NOTES

Figure 15 Sample of Deposit Field Record sheet

**PAPHOS THEATRE EXCAVATIONS – 1999
BASIC SHERD COUNT**

TRENCH: _____ DEPOSIT: _____
DATE: _____ INITIALS: _____

| WARE | SMALL OPEN | | LARGE OPEN | | SMALL CLOSED | | LARGE CLOSED | | OTHER | | TOTAL | | DIAG- NOSTIC No | INVEN- TORY No |
|------------------------|------------|-----|------------|-----|--------------|-----|--------------|-----|-------|-----|-------|-----|-----------------------|----------------------|
| | No | WT. | No | WT. | No | WT. | No | WT. | No | WT. | No | WT. | | |
| Hellenistic | | | | | | | | | | | | | | |
| Roman Red Slip | | | | | | | | | | | | | | |
| Roman Plain | | | | | | | | | | | | | | |
| Amphora | | | | | | | | | | | | | | |
| Cooking Ware | | | | | | | | | | | | | | |
| Byzantine | | | | | | | | | | | | | | |
| Medieval Glazed | | | | | | | | | | | | | | |
| Medieval Plain/Incised | | | | | | | | | | | | | | |
| Tile/ Architecture | | | | | | | | | | | | | | |
| Other | | | | | | | | | | | | | | |
| Total | | | | | | | | | | | | | | |

1

Inv.no. 1124

Material Pottery- Stone- Metal- Lamp- Other
 Terracotta- Stone inscr- Coin- Glass-

Ht 0.012 diam % width 0.020 dpth

Brief descr Fr of lip of small Attic bg dish

Period Hellenistic Roman Byzantine Medieval Later Unknown

Drawing _____ Picture _____

State pres Small, and slightly worn about the lip, but generally in good condition

Fabric _____

Description Rim and upper wall fr of small shallow Attic bg dish. On the upper face there is a step marking off the lip zone and the rim has a flat upper face. On the outer face there is a broad groove on the underside of the lip.

Notes on Object _____

Findspot: Grid 3A Findspot: Deposit 069

Notes on Findspot Pebbly occupation fill between main drain and road

Date excavated 1/4/1996 Excavator Helen Nicholson

Neg.no. _____

Drawing ref. AD 26/4/98 (scan)

Location _____

Publication refs _____

Cataloguer JRG & AHR Date cat. 16/4/1998

2

Figure 16 Sample of Sherd Count sheet and Main Inventory form

PAPHOS THEATRE EXCAVATIONS - 1997
DIAGNOSTIC POTTERY

INVENTORY No. DEPOSIT call DIAGNOSTIC SHERD No.

Complete - Fragment >2/3 >1/3 <1/3

WARE PARTS REPRESENTED rim - handle - base - neck - spout

SHAPE

MOUTH TYPE round - ds-away - pinched - lateral

MOUTH ANGLE horizontal - forward slope - backward slope

RIM COURSE vertical - flaring - everted - incurved - T-shape - pendent

RIM PROFILE constant - thinning - thickening - swelling

RIM END rounded - flattened - pointed - indented

BASE TYPE round - flat - pointed - knob - stump - ring - foot

HANDLE TYPE horiz - high vert - low vert - pierced ledge - unpierced ledge

HANDLE LOCATION from rim - below rim - mid neck - lower neck

SECONDARY HANDLE loop - ledge

SPOUT TYPE open - tubular - bridge

NECK TYPE cylindrical - upward taper - widening - concave - convex

LUG pierced - unperced single - multiple number

Total ht. _____ Body ht. _____ Neck ht. _____ Ht. max. body diam. _____

Rim Ext diam. _____ Rim Int diam. _____ Base diam. _____

Body Ext diam. _____ Body Int diam. _____ Neck diam. - top. _____ mid. _____ base _____

Wall thickness - rim _____ below rim _____ body _____ base _____

EVIDENCE OF MANUFACTURE _____

SURFACE TREATMENT exterior _____ interior _____

SURFACE COLOUR exterior _____ interior _____

FABRIC colour _____ texture _____ inclusions _____ hardness _____

DECORATION: relief - incised - impressed - painted

RELIEF MOTIFS _____

INCISED MOTIFS _____

IMPRESSED MOTIFS _____

PAINTED MOTIFS _____

B&W Photo

Colour Photo

Drawing

COMPUTER

1

Pottery Form

| | | | | | |
|-----------------|---------------|---------------|----------|-------------------------|--|
| Auto No | 1025 | Lamp | | Surface Treatment - Ext | No Slip |
| Inventory No | 481 | Lug | | Surface Treatment - Int | No Slip |
| Artifact Type | Pottery | Neck Type | | Surface Colour - Ext | |
| Trench | 3B | Spout | | Surface Colour - Int | |
| Deposit No | 84 | Total Height | 75 | Fabric - Colour | light greenish/brown |
| Ware | Plain Ware | Body Height | | Fabric - Texture | Medium/Coarse |
| Form No | | Neck Height | | Fabric - Inclusions | many large black, red and grey, traces |
| Shape | Cup | Rim - Ext Dia | 73 | Fabric - Hardness | Medium |
| Rim Course | Everted | Rim - Int Dia | | | |
| Rim Profile | Thinning | Thick - Rim | | | |
| Rim End | Rounded | Thick - Below | | | |
| Base Type | | Base Dia | | | |
| Body | | Neck Dia | | | |
| Handle Type | High Vertical | Thick - Body | | | |
| Handle Location | From Rim | Drawing No | Fig 92.3 | | |

Evidence of Manufacture
Complete but for some chips from the lip

Decoration
horizontal grooves on ext shoulder

Comparisons
Bass, Yassi Ada, 1982, Fig.8-14:P32, p.172-74, (7th century)

Scale 1:2

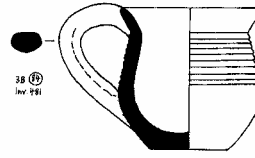

2

Figure 17 Sample of Diagnostic sherd form and Inventory Database form

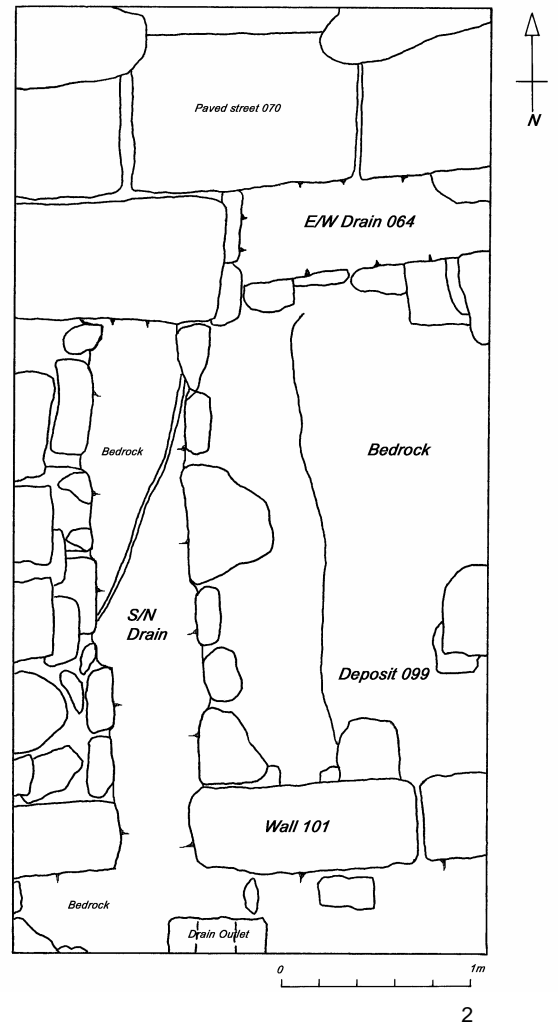
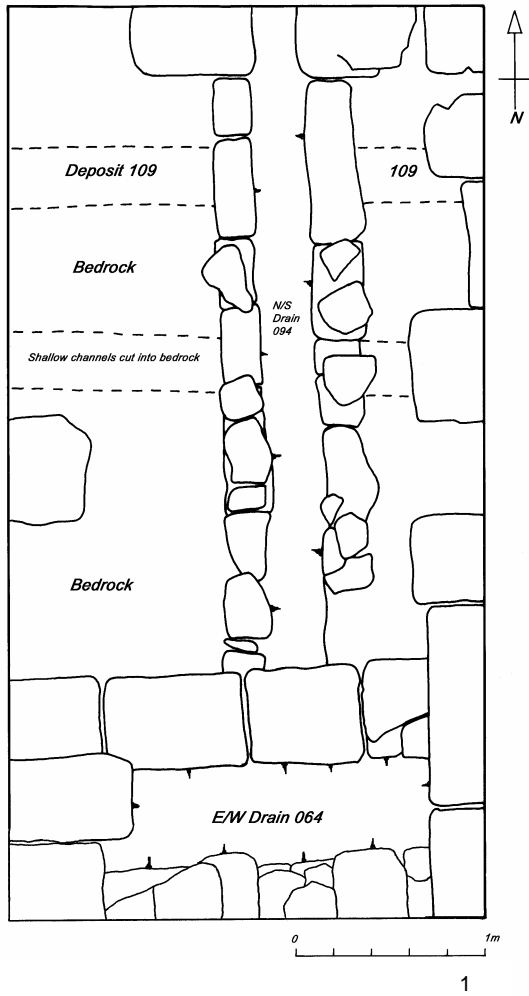

Figure 18 Plan of trenches 3A and 3B

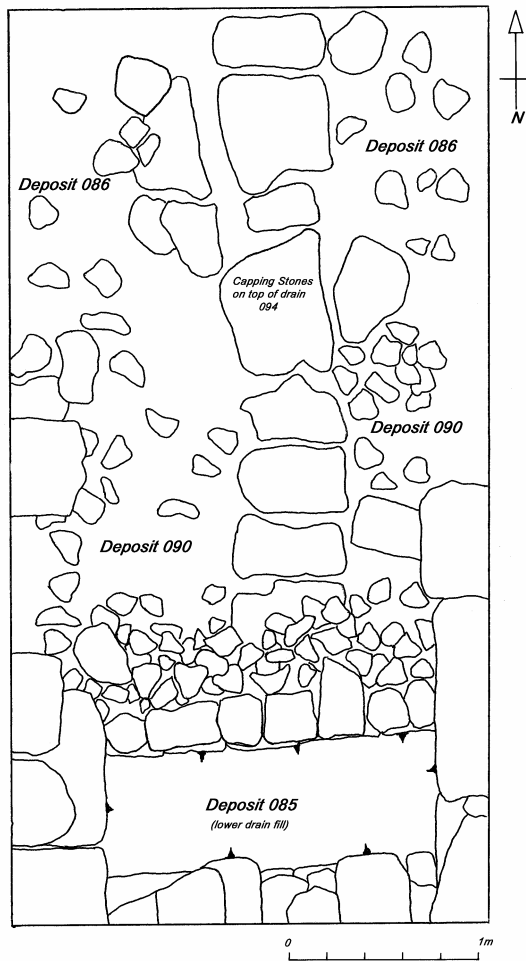

Figure 19 Plan of early street? level in 3A

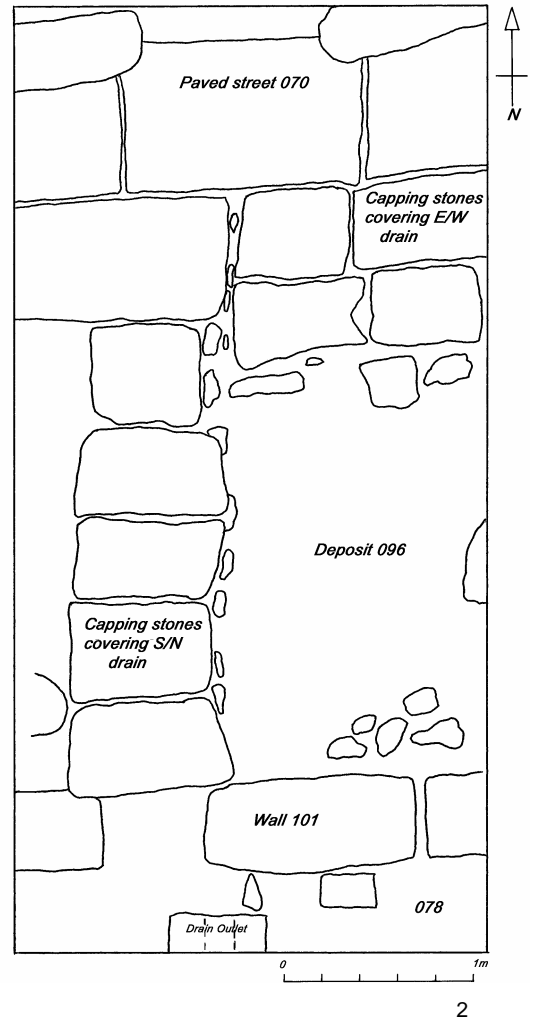
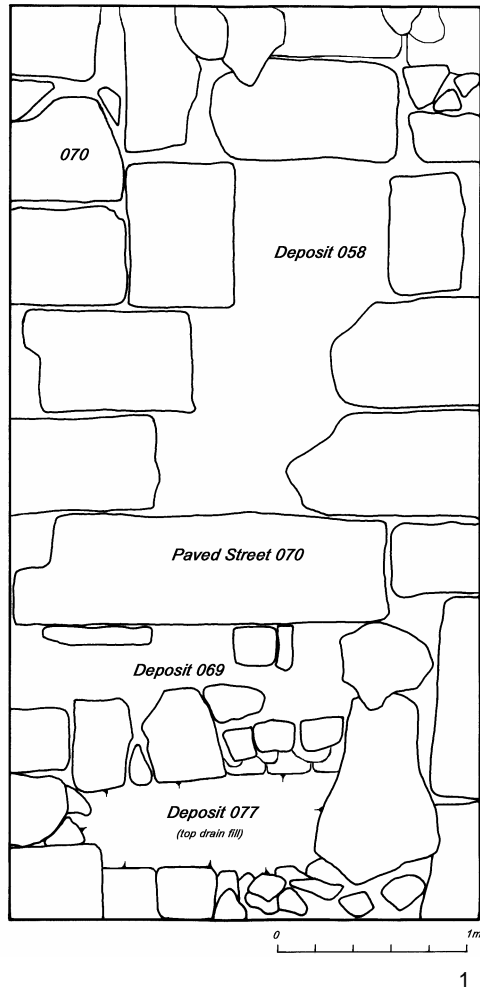
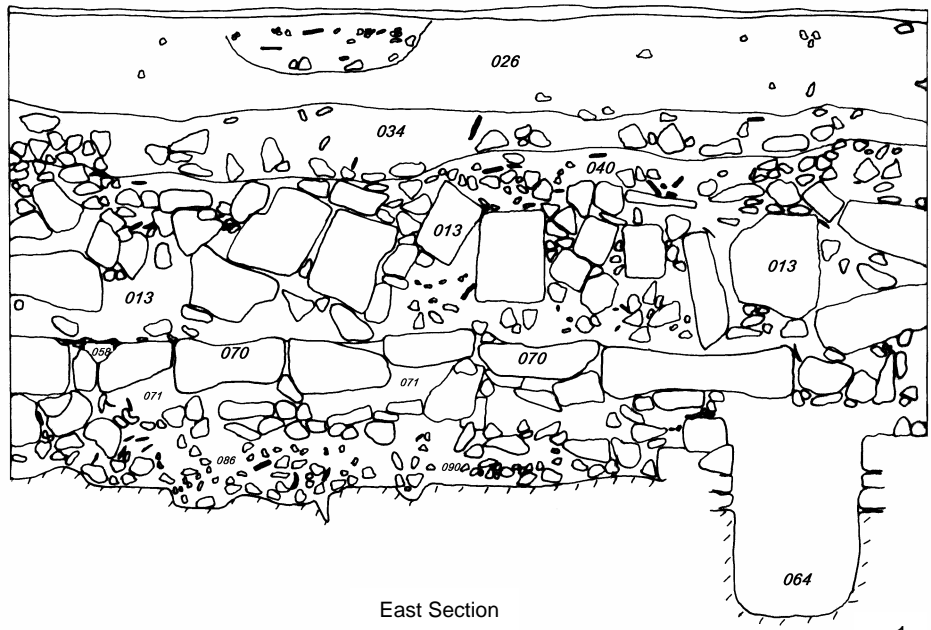
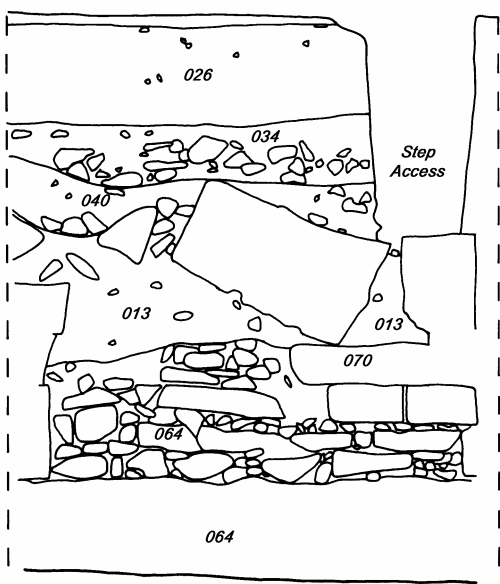

Figure 20 Plan of paved street in 3A and 3B



East Section

1



South Section

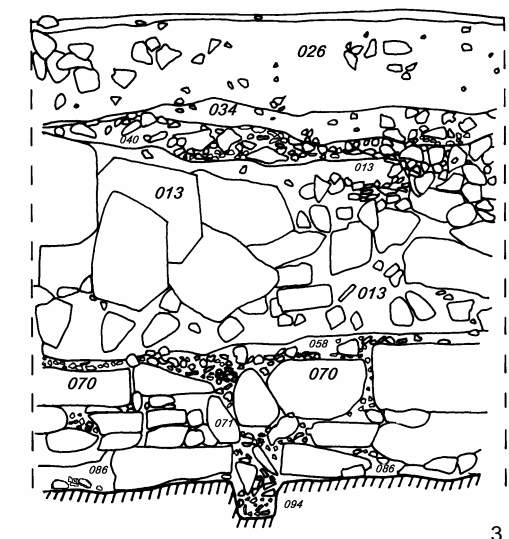

North Section

3

2

Figure 21 Section drawings from 3A

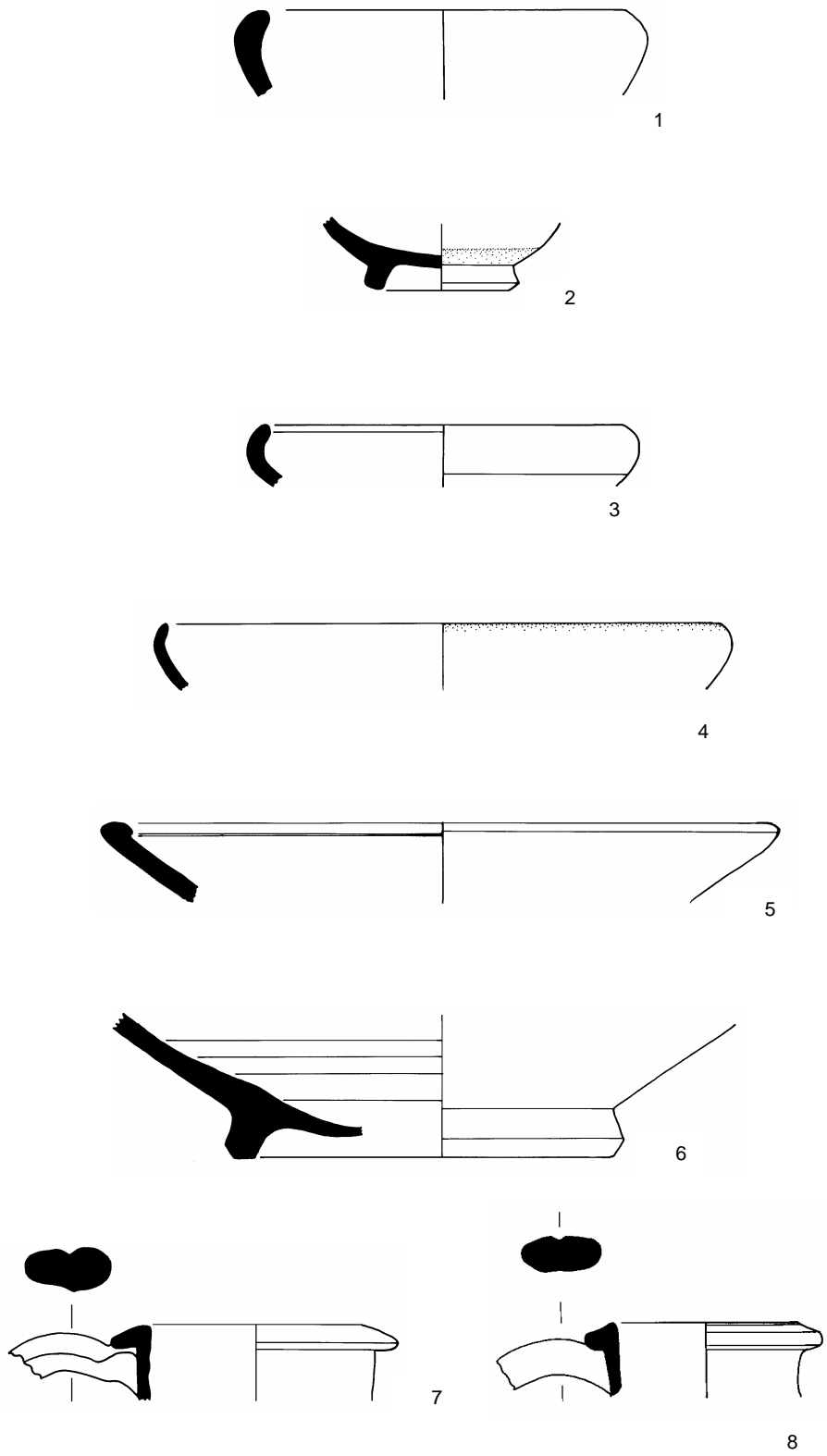
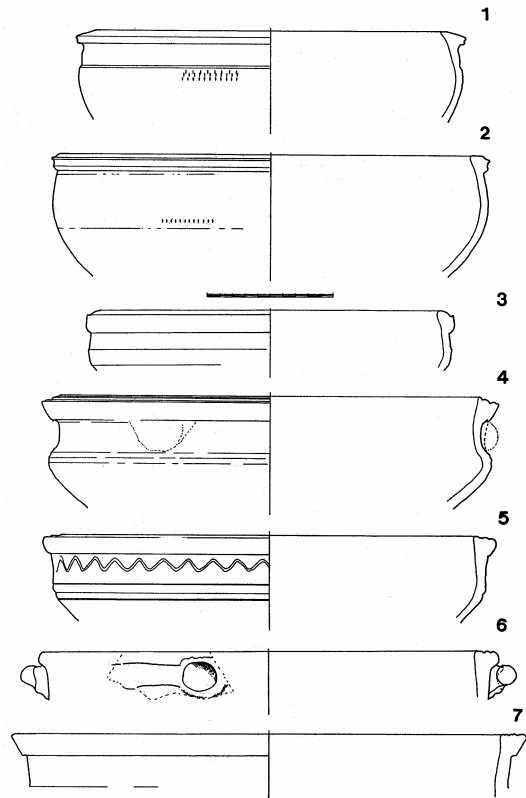
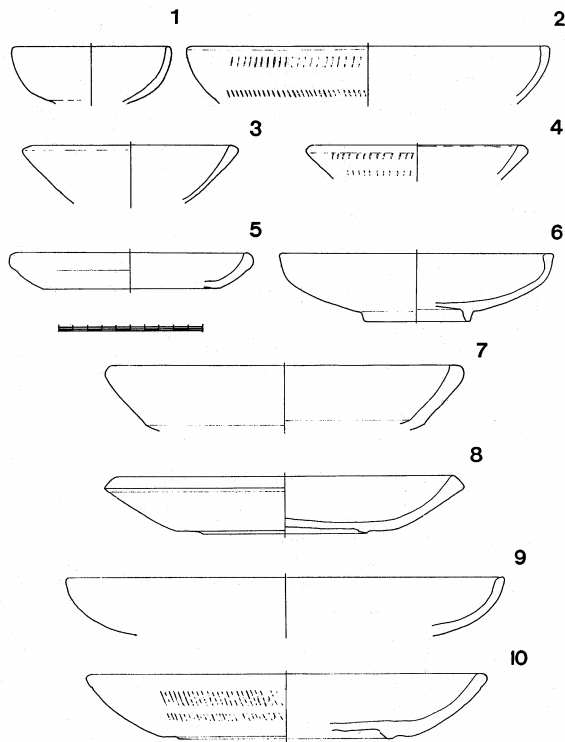

Figure 22 Cyriot Hellenistic Colour-Coated ware. Scale 1:2



Possible development of CS forms P40-P42 to CRSW Hayes' form 7.



Two lines of development from CS form P29 to CRSW hemispherical/funnel-shaped bowl and a wide plate — Hayes' form 1.

Figure 23 Typological developments from Cypriot Sigillata to Cypriot Red Slip ware (Source; Meyza, 1995)

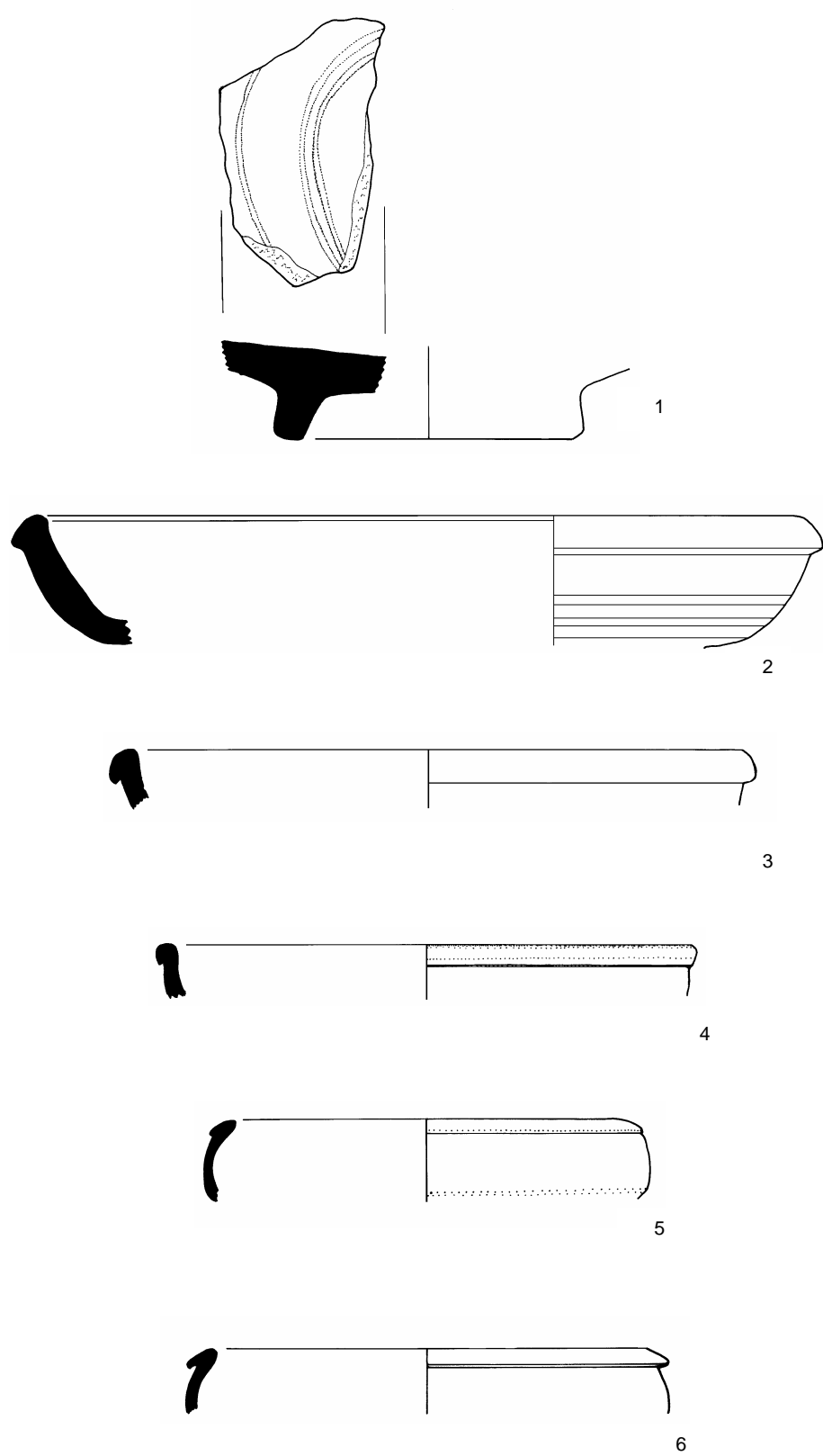

Figure 24 Cyprriot Sigillata dishes and bowls. Scale 1:2

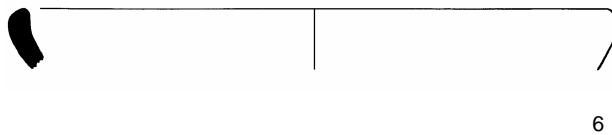
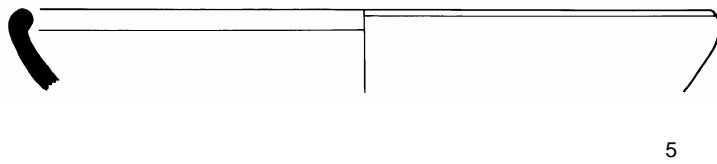
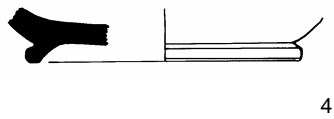
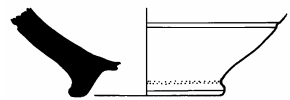
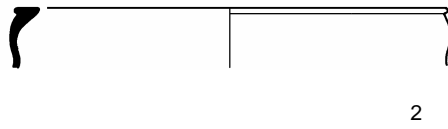

Figure 25 Cypriot Sigillata bowls. Scale 1:2

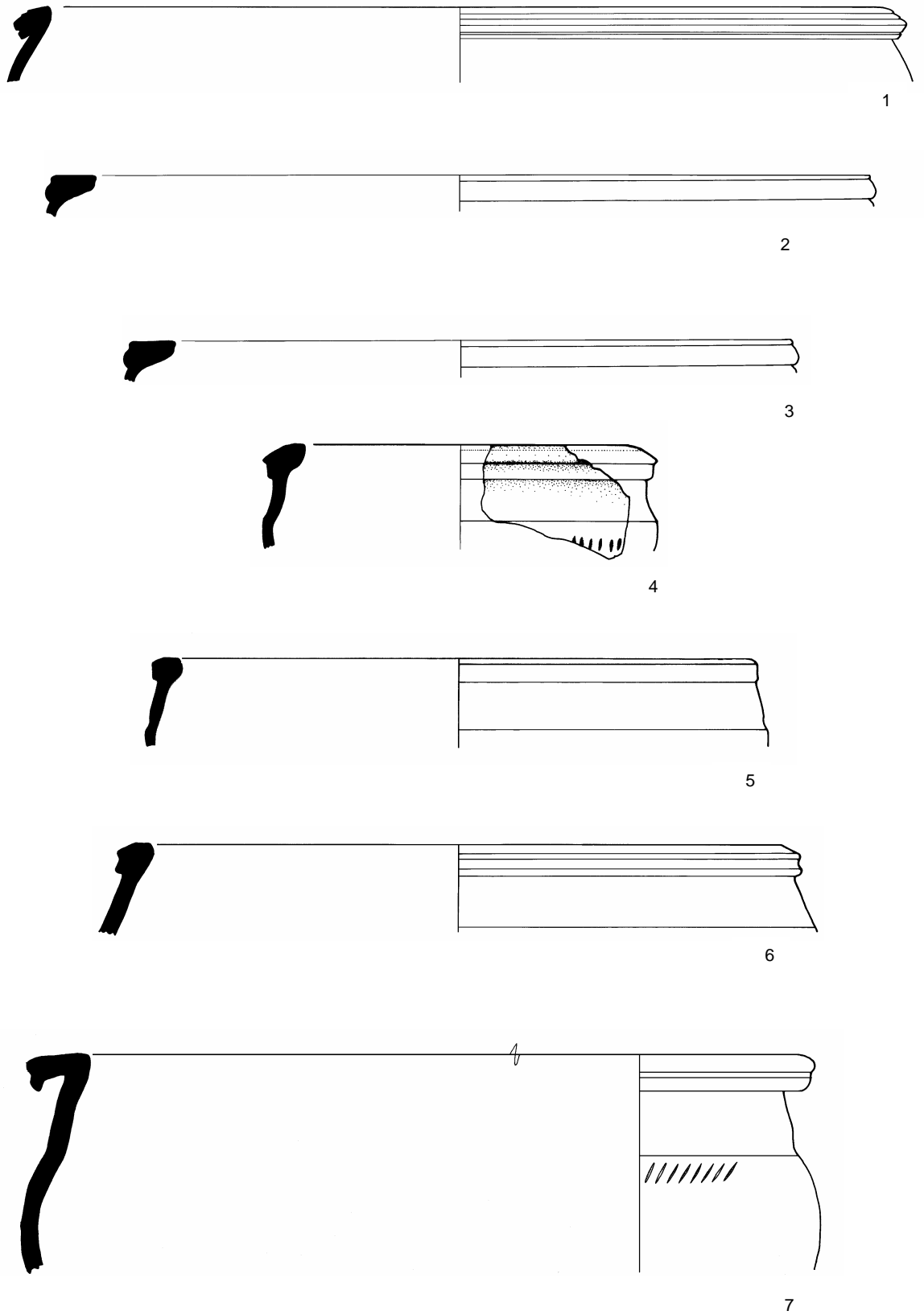

Figure 26 Cyriot Sigillata kraters. Scale 1:2

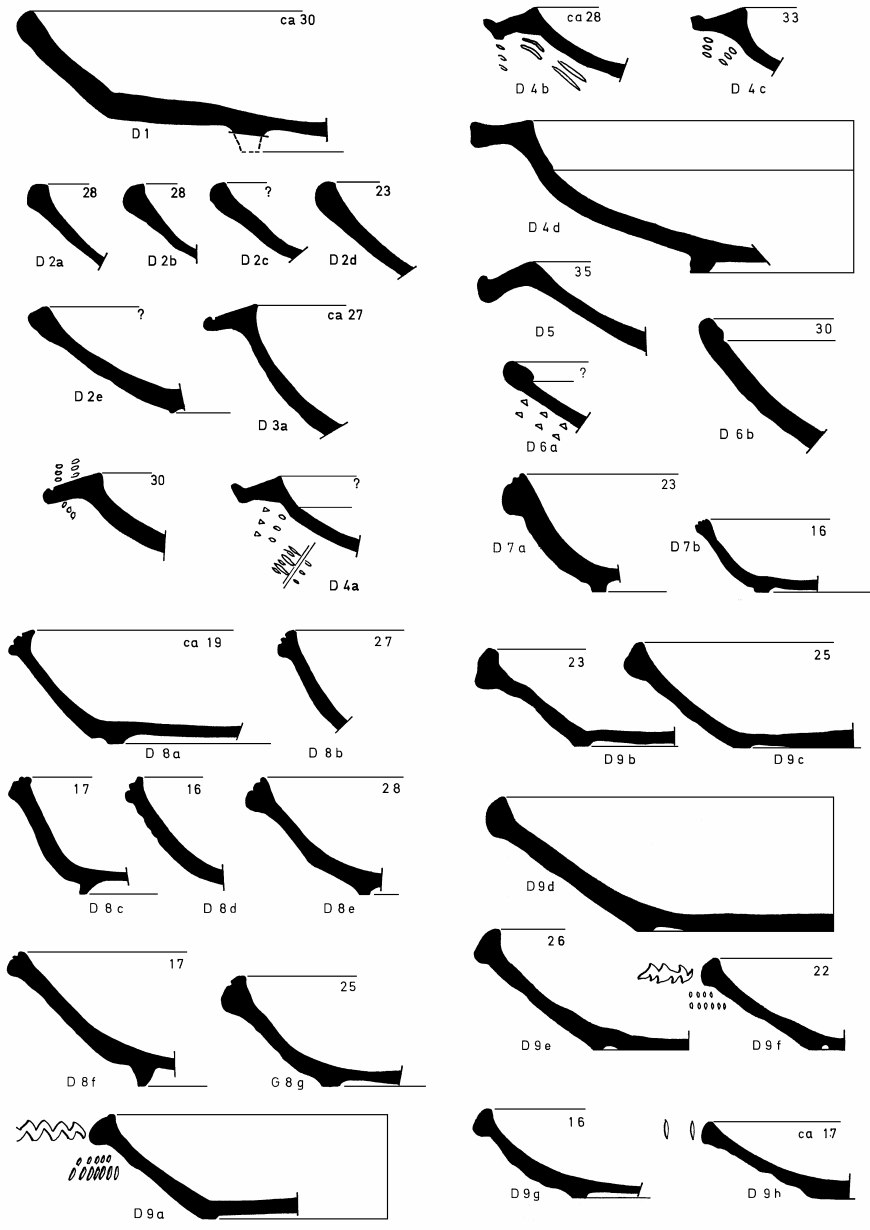

Figure 27 Cypriot Red Slip ware typology from Kôm el-Dikka (Source; Rodziewicz 1976)

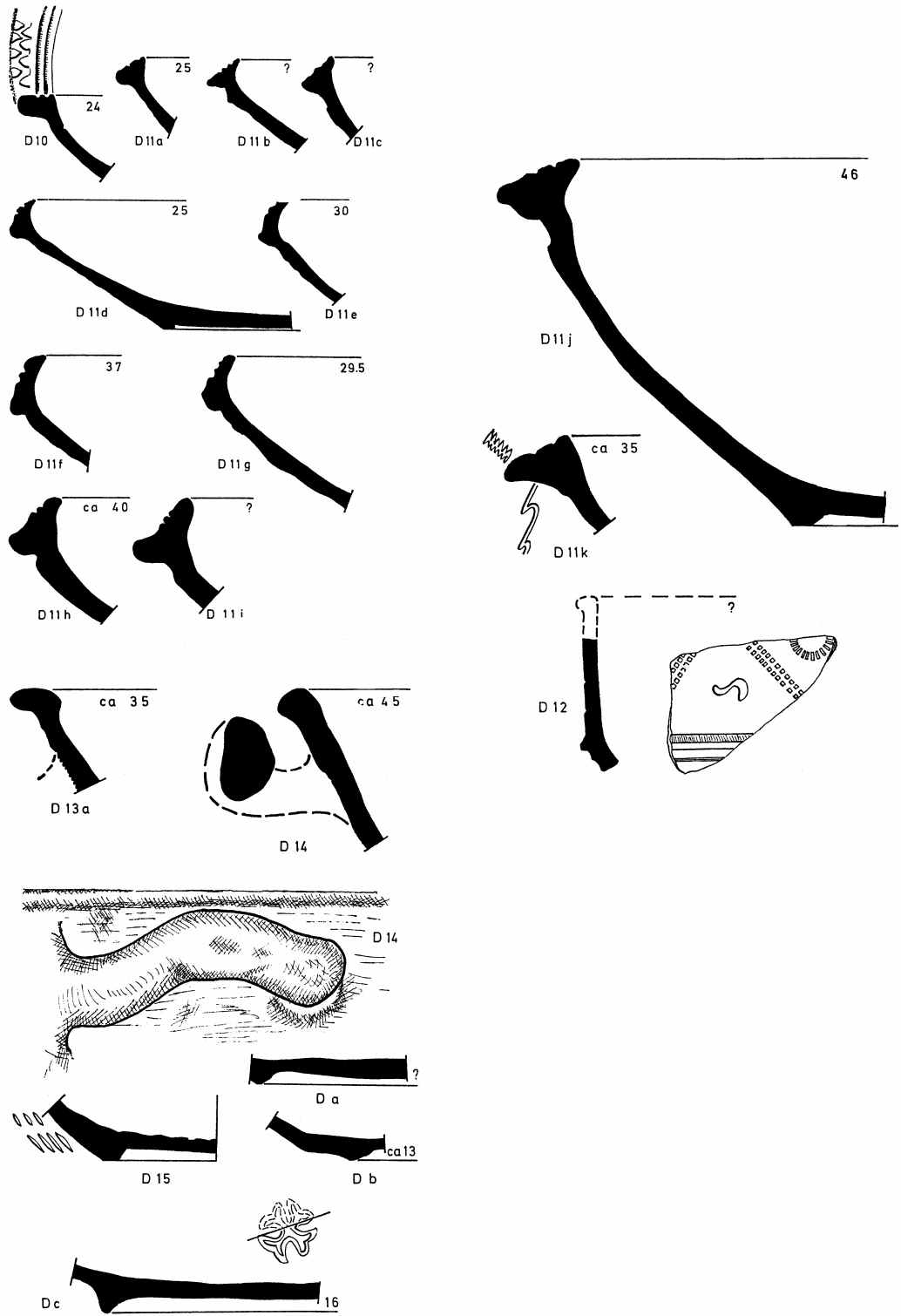

Figure 28 Cypriot Red Slip ware typology from Kôm el-Dikka (Source; Rodziewicz 1976)

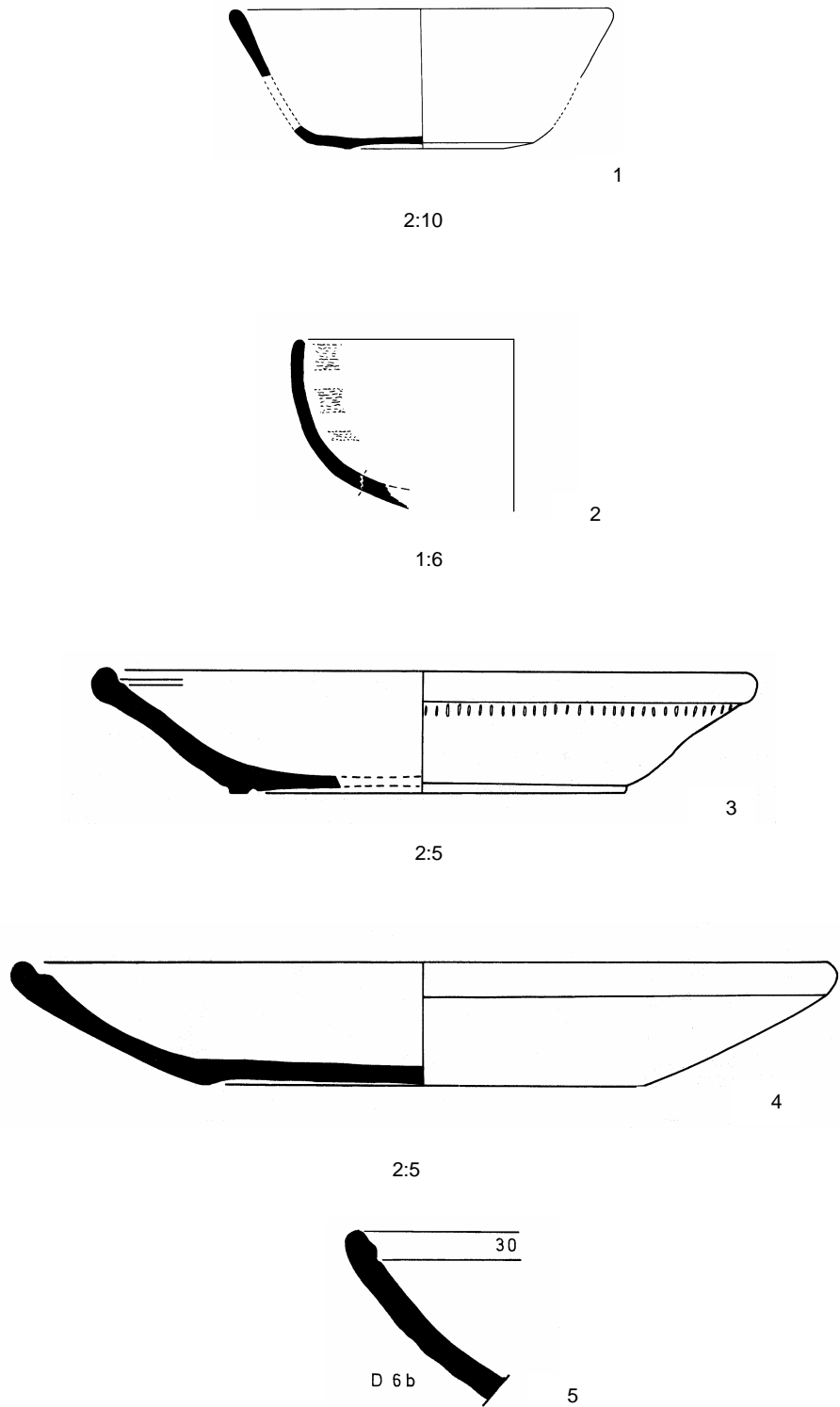

Figure 29 Cyriot Red Slip ware Form 1

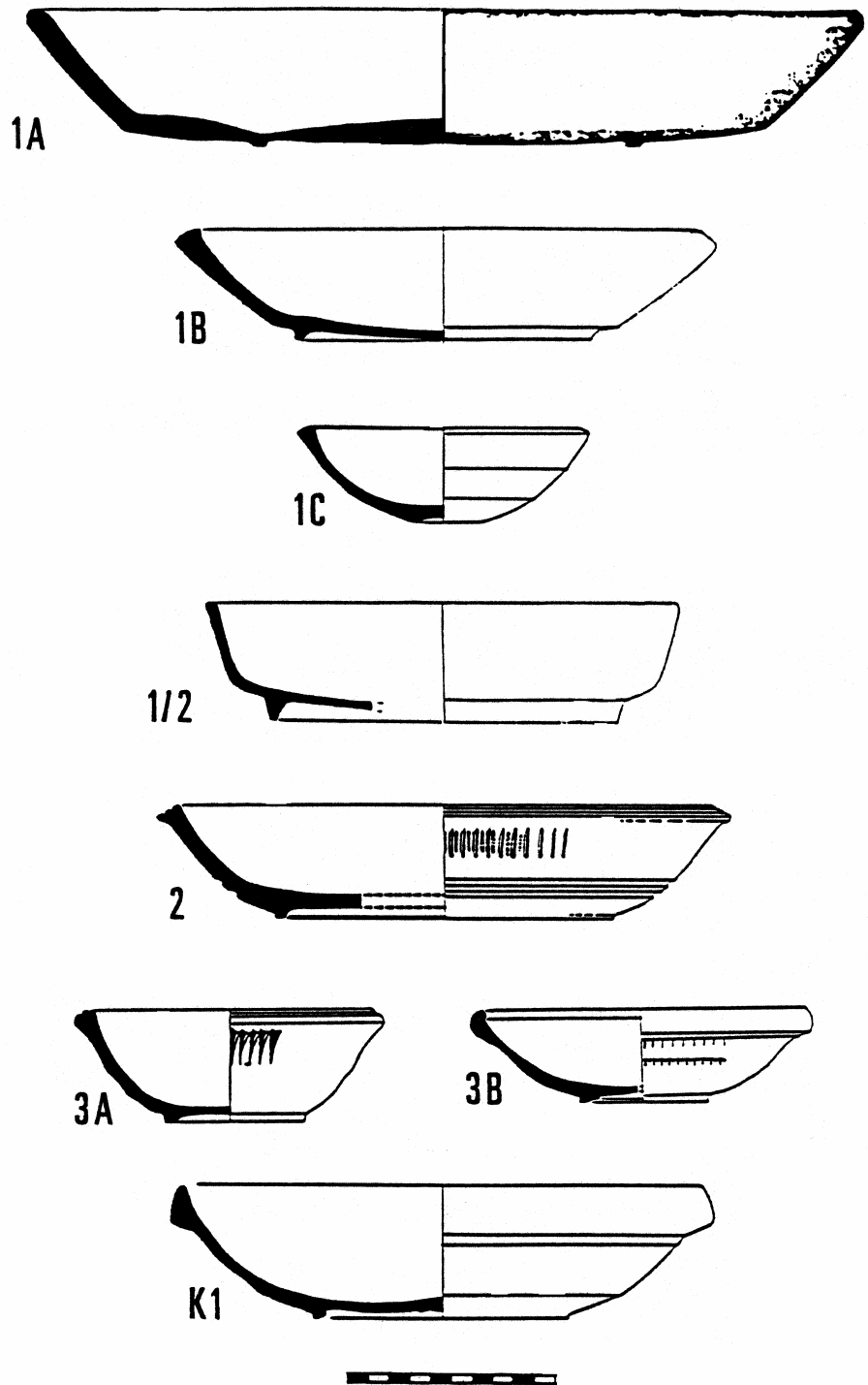

Figure 30 Revised typology for Cypriot Red Slip ware Part 1 (Source; Meyza, 2000)

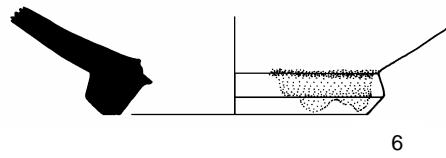
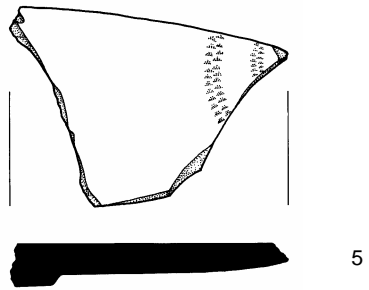
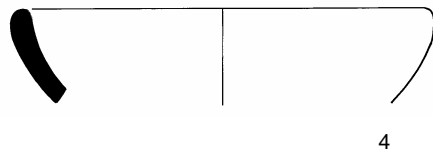
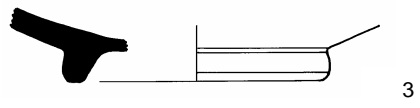
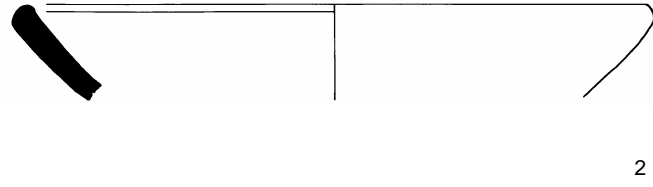
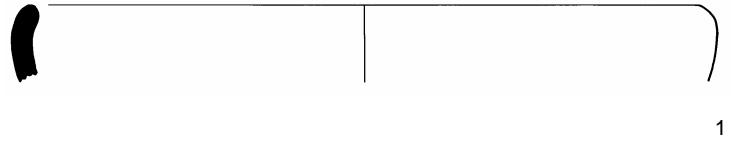

Figure 31 Cyproit Red Slip ware Form 1. Scale 1:2

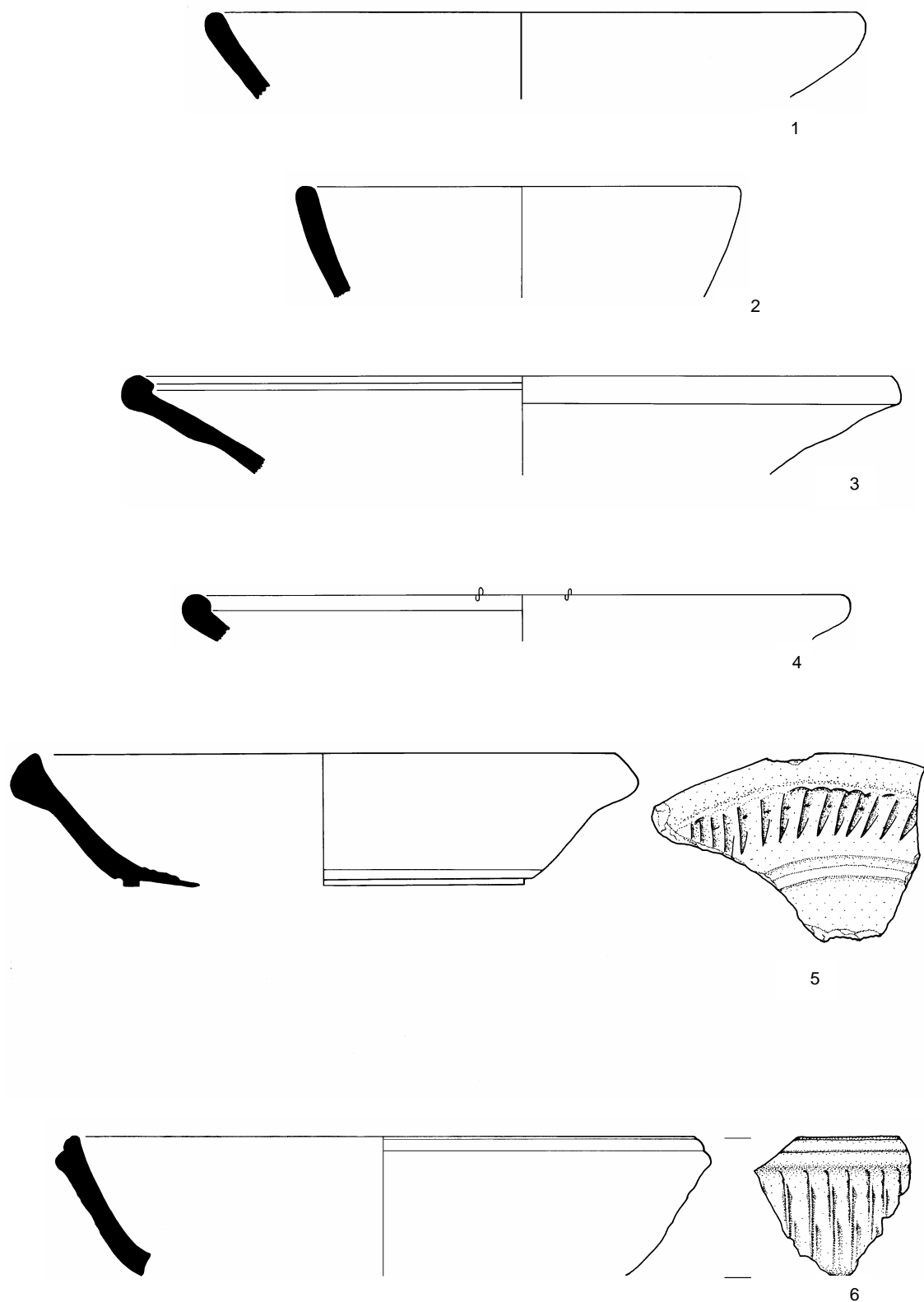

Figure 32 Cyriot Red Slip ware Forms 1 & 2. Scale 1:2

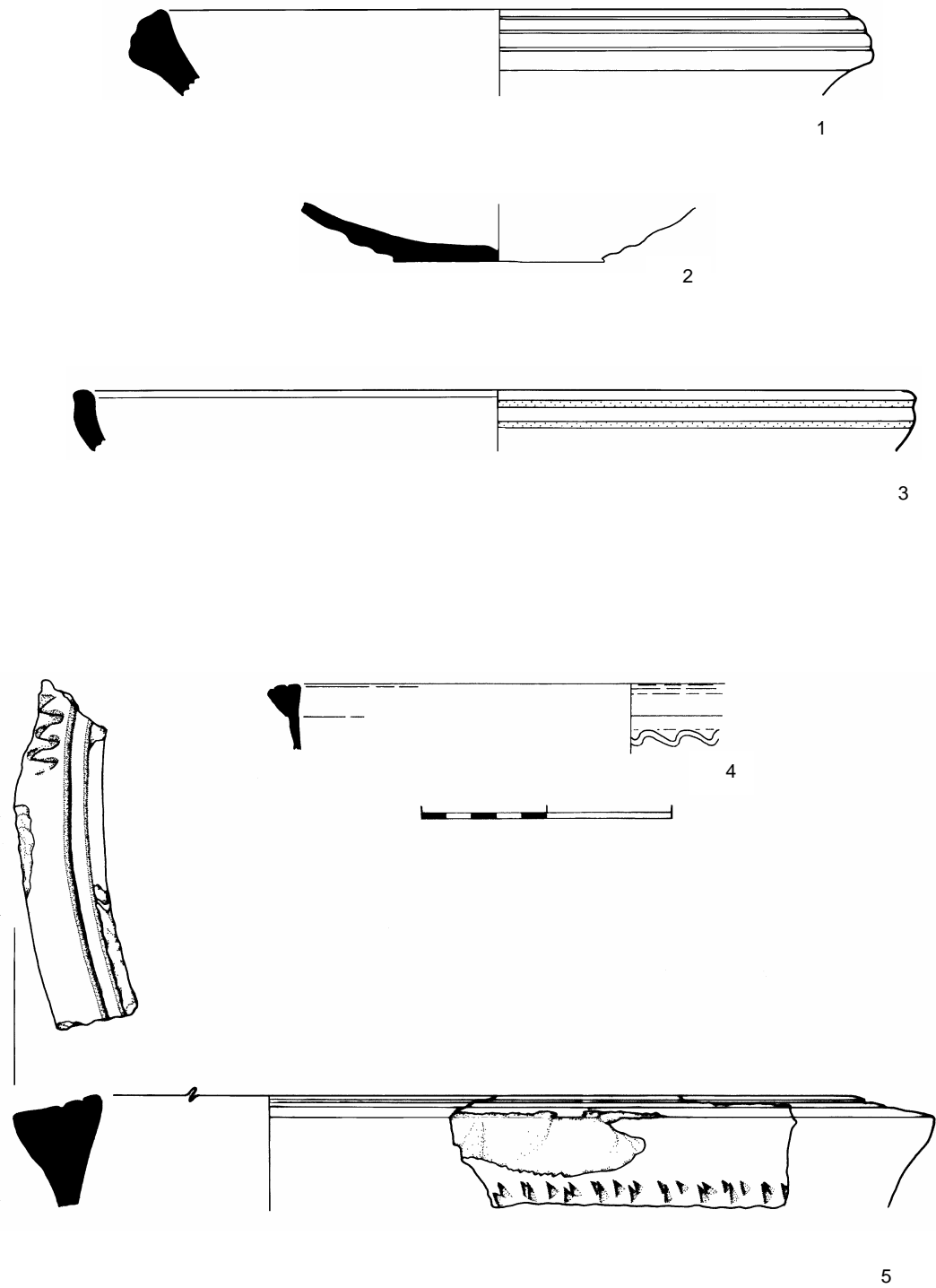

Figure 33 Cyriot Red Slip ware Forms 3, 5 & 7. Scale 1:2

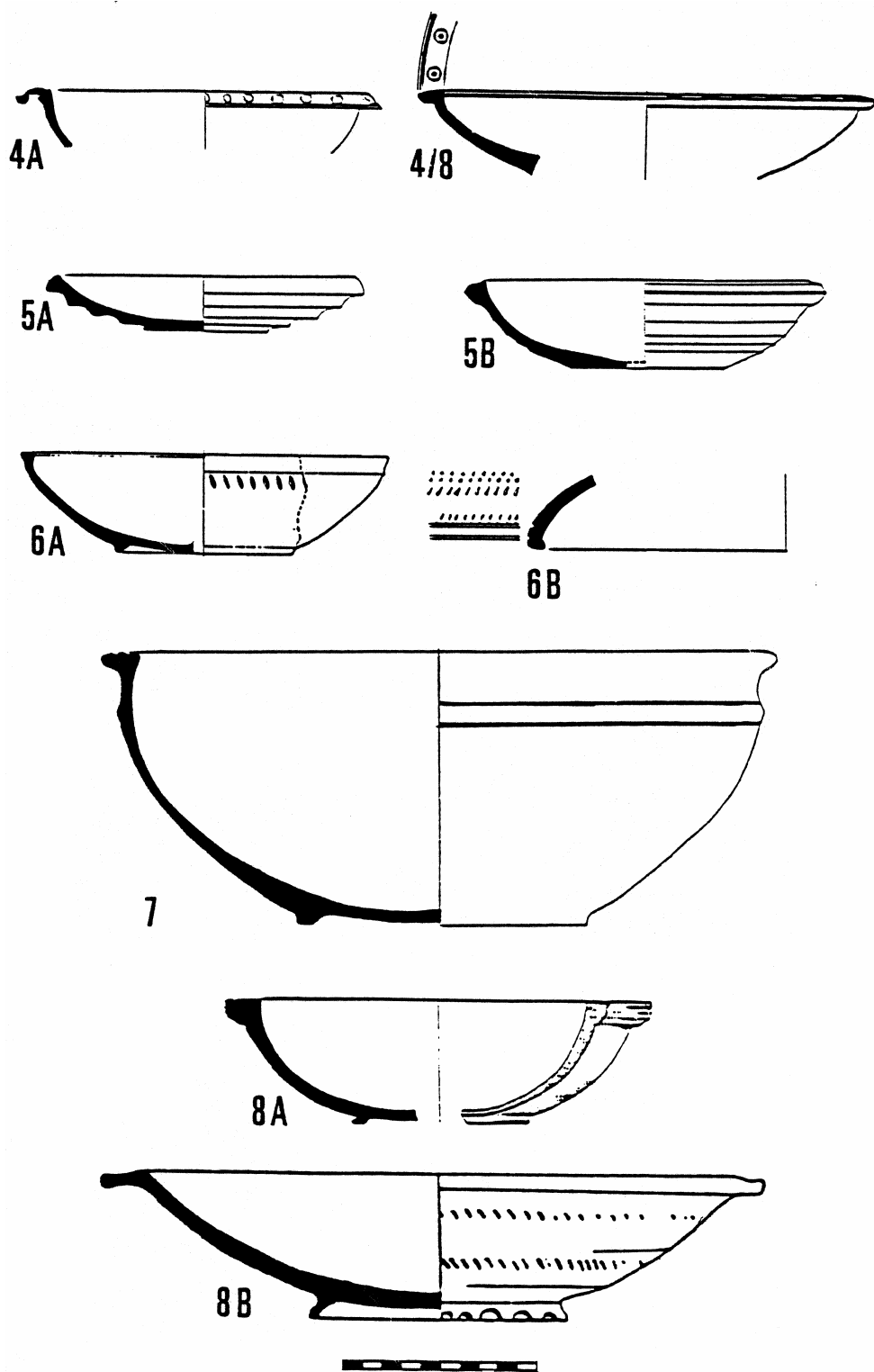

Figure 34 Revised typology for Cypriot Red Slip ware Part 2 (Source; Meyza, 2000)

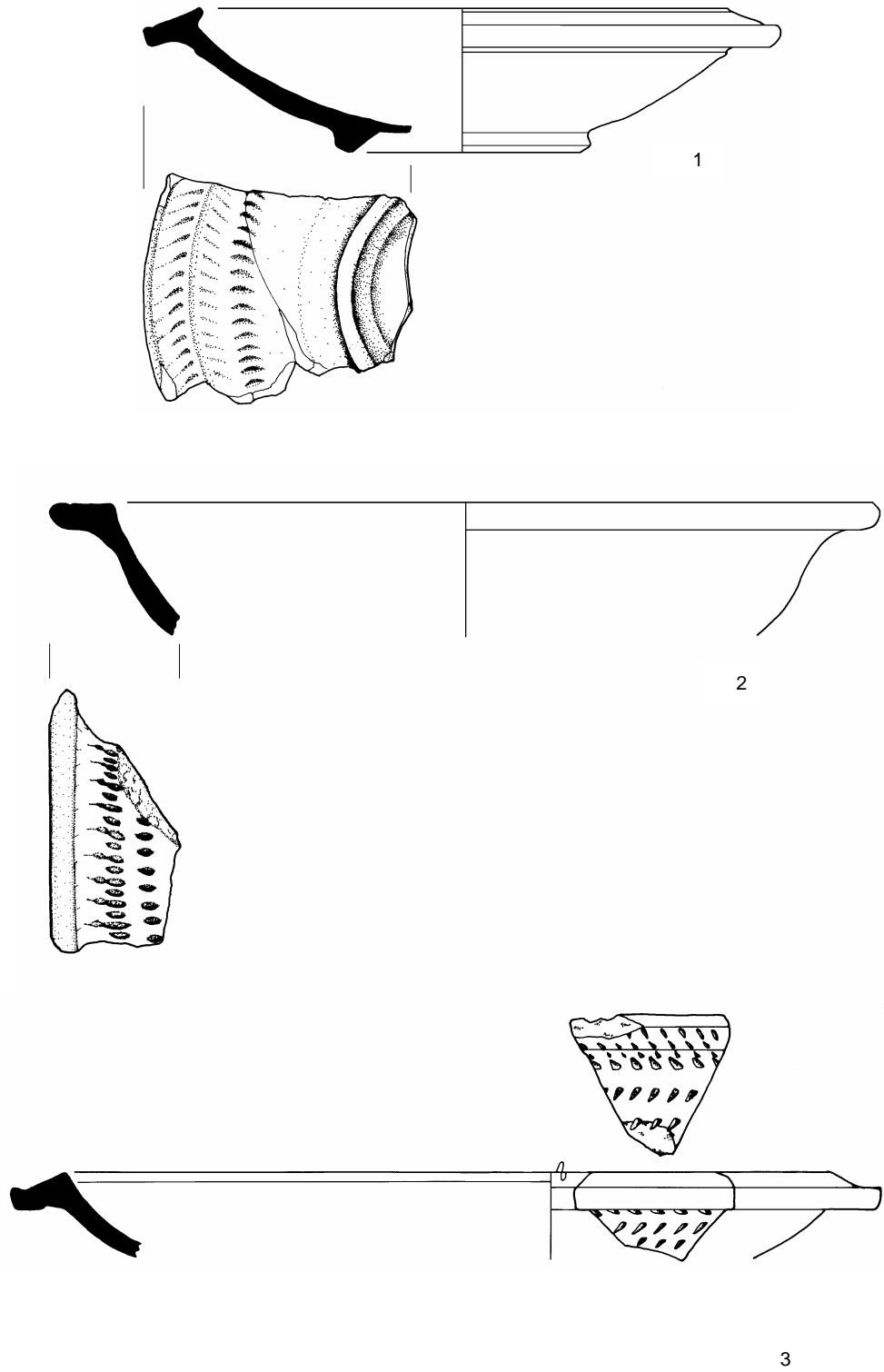

Figure 35 Cyproit Red Slip ware Form 8. Scale 1:2

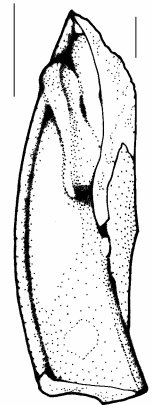
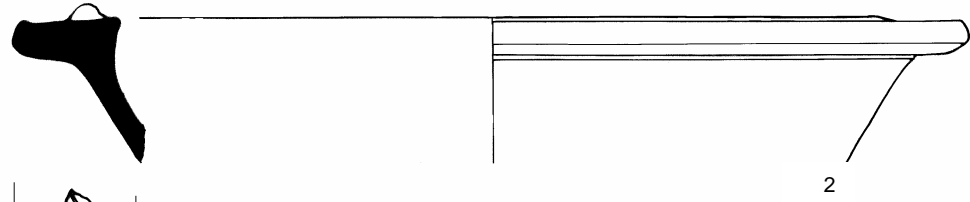
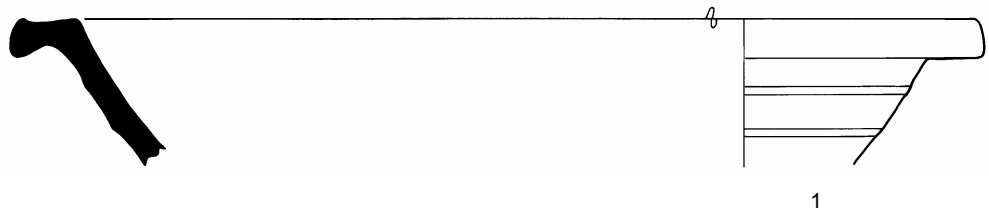

Figure 36 Cypriot Red Slip ware Form 8. Scale 1:2

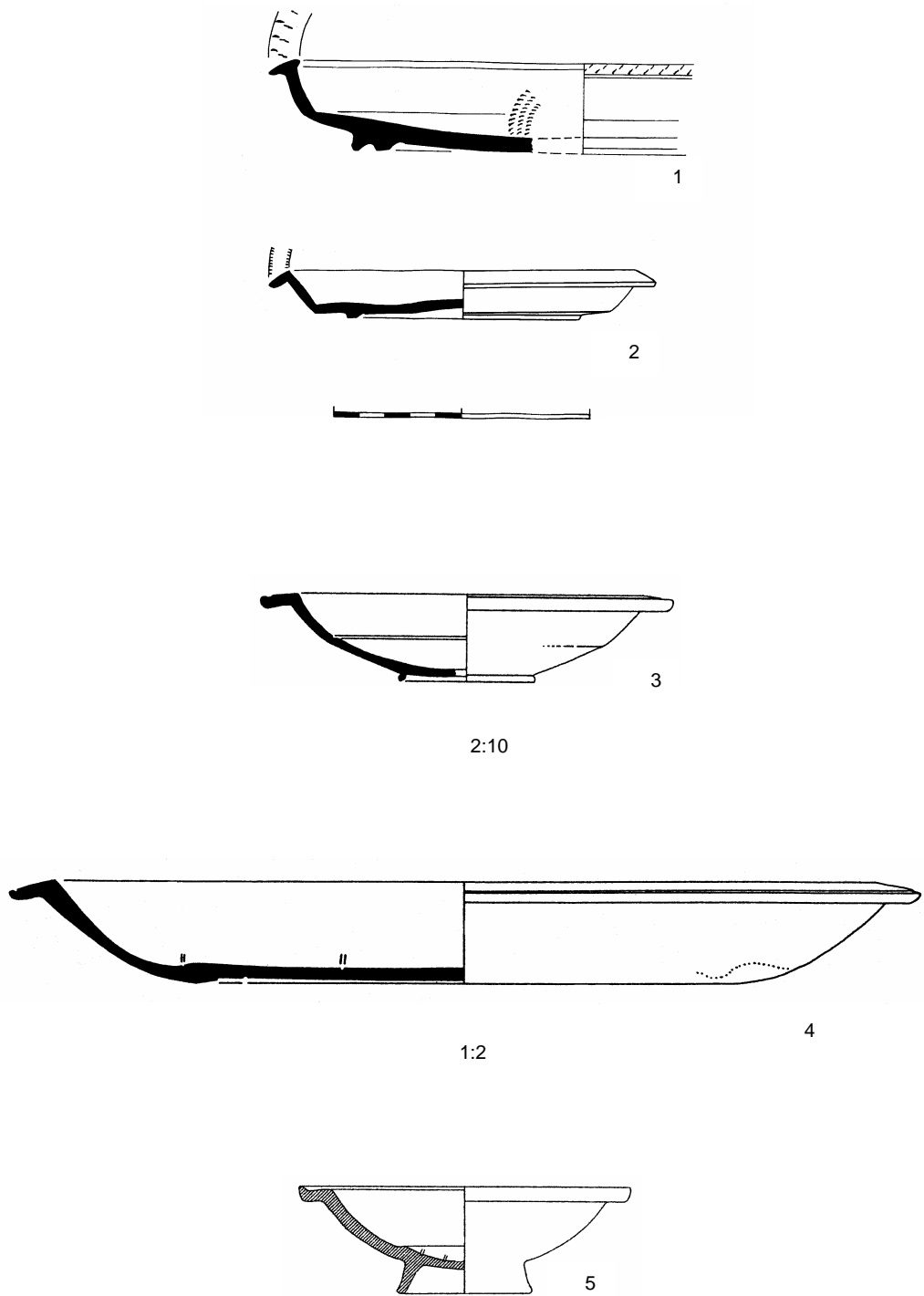

Figure 37 African Red Slip ware forms similar to CRSW Form 8

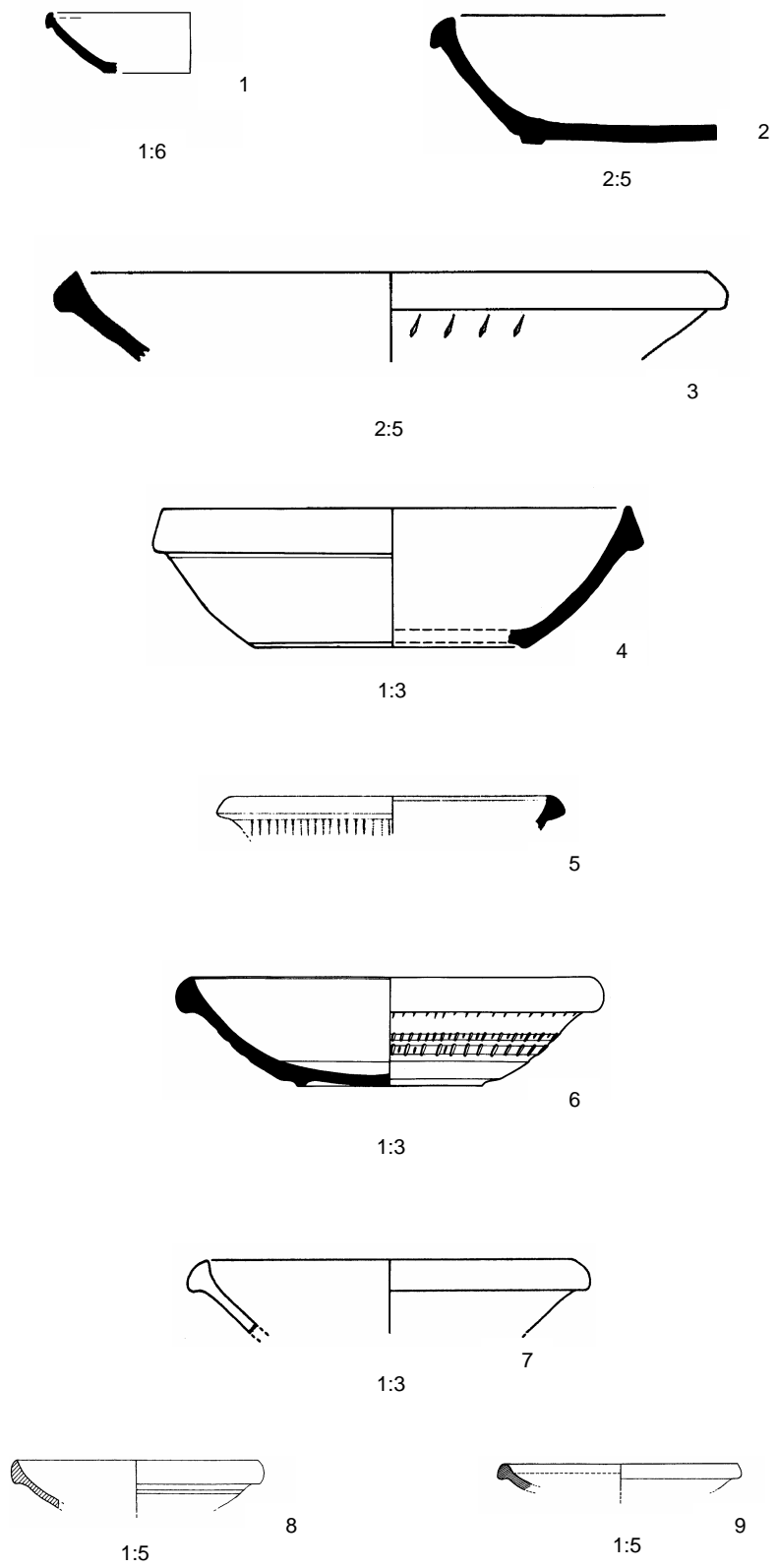

Figure 38 Cyprriot Red Slip ware Form K1? from other sites

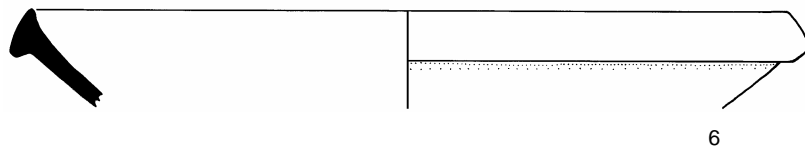
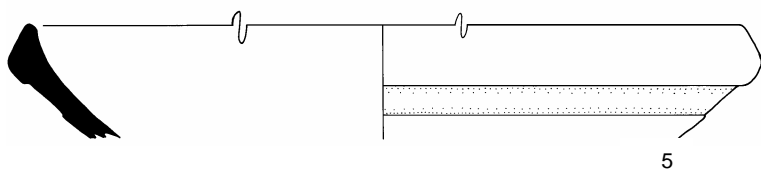
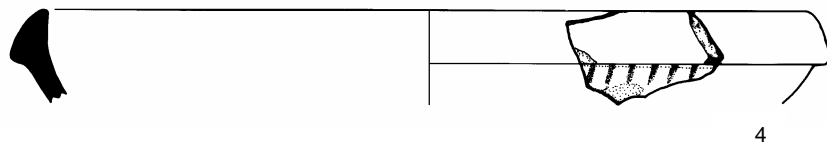
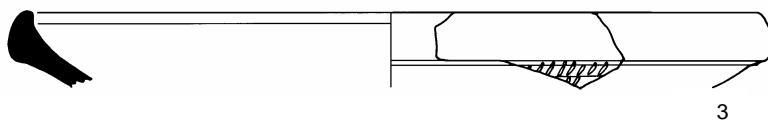
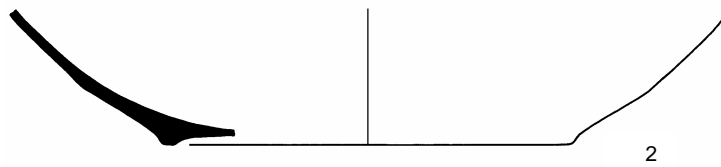
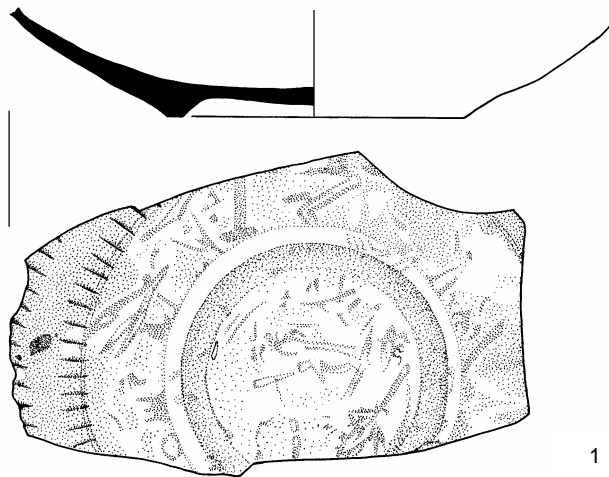

Figure 39 Cyproit Red Slip ware Form K1. Scale 1:2

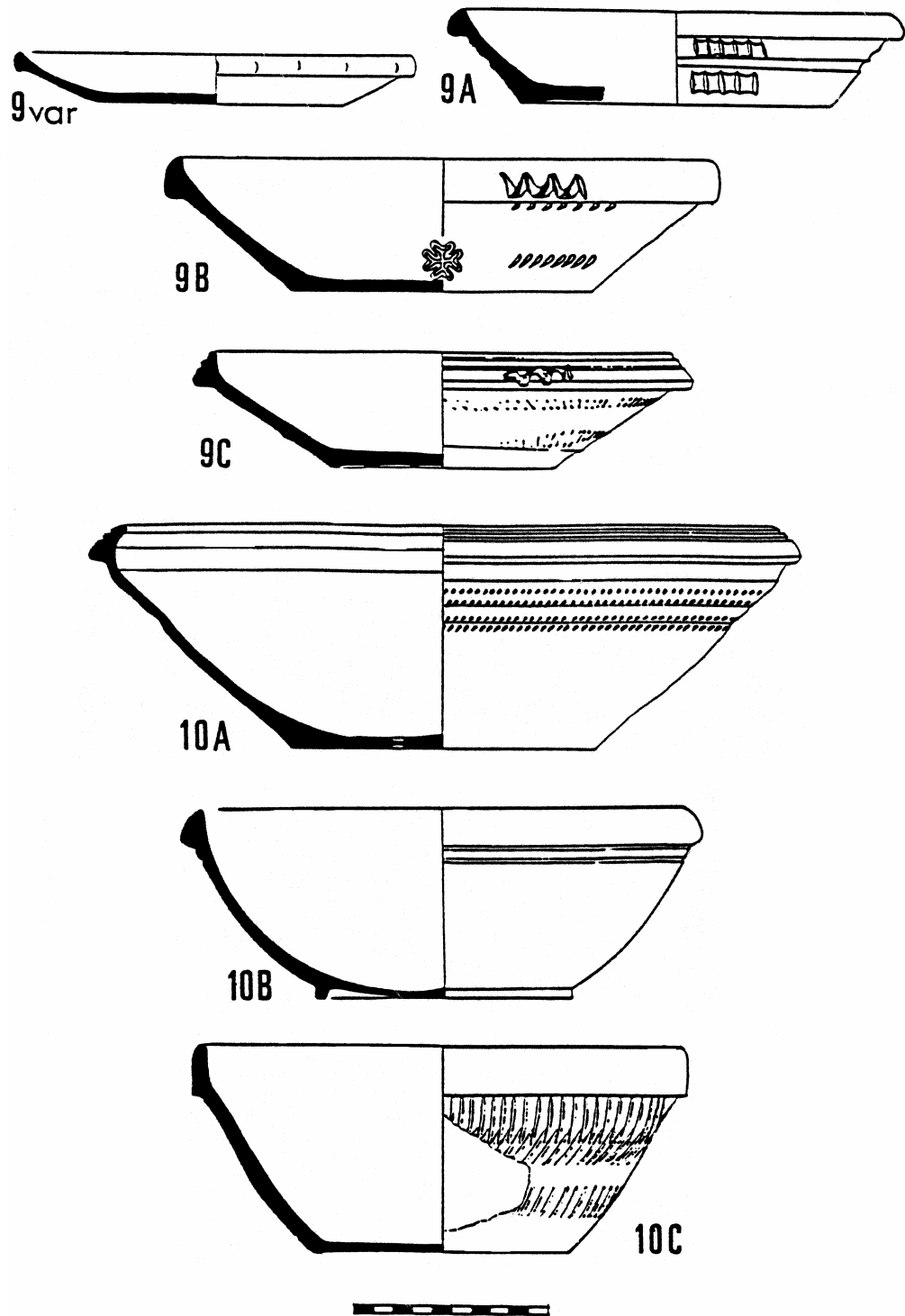

Figure 40 Revised typology for Cypriot Red Slip ware Part 3 (Source; Meyza, 2000)

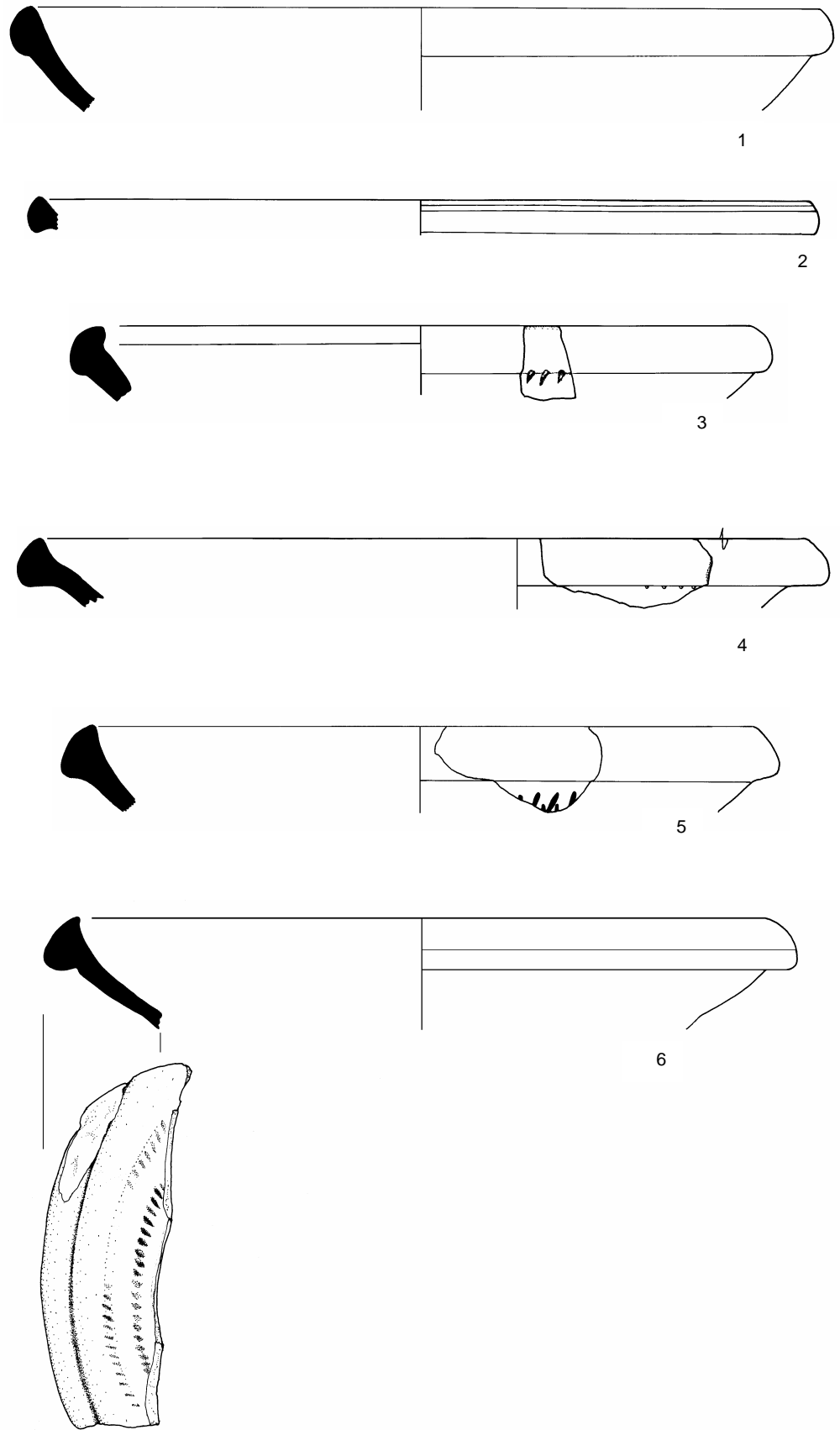

Figure 41 Cypriot Red Slip ware Forms 9var and 9A. Scale 1:2

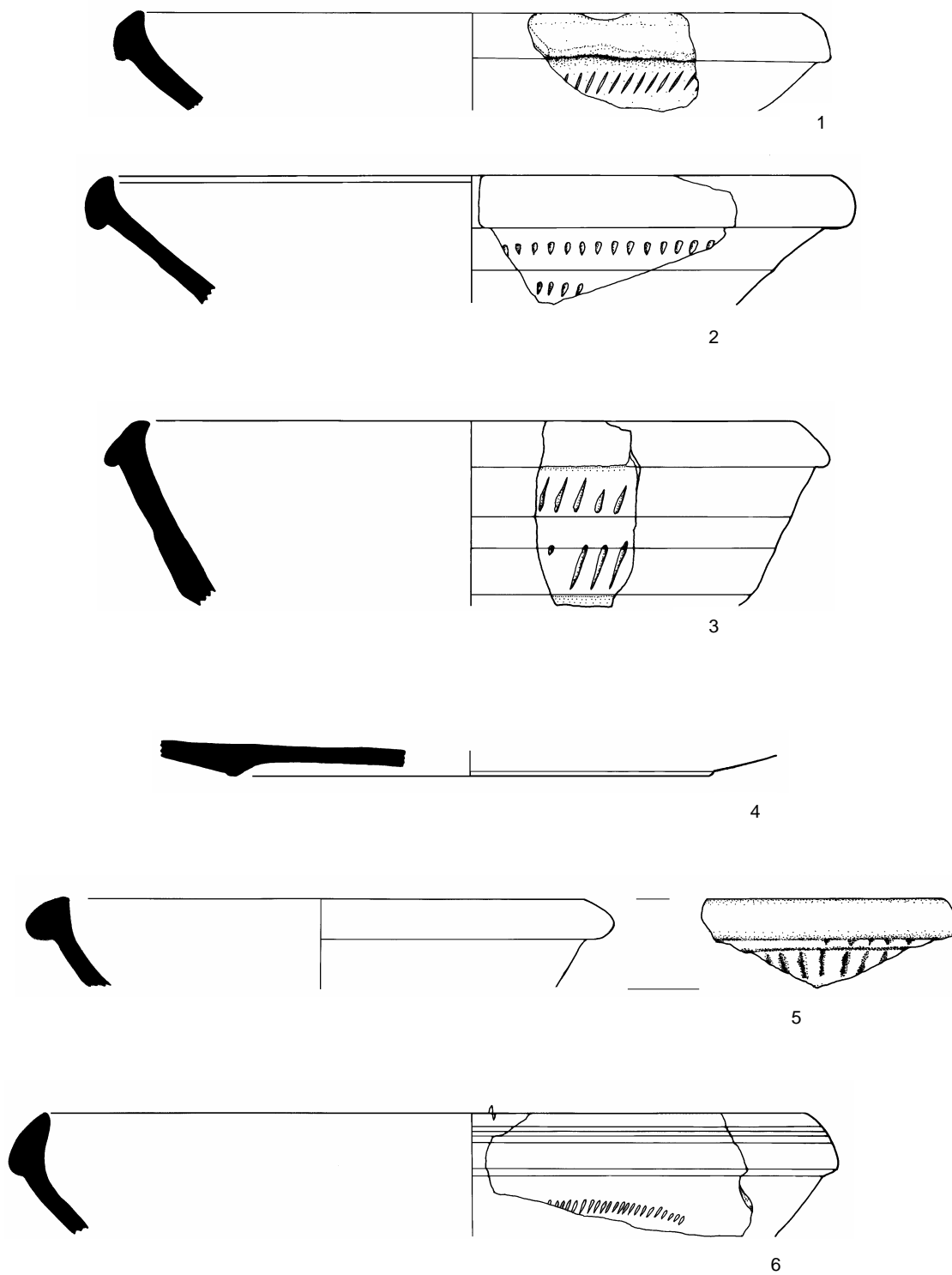

Figure 42 Cyprriot Red Slip ware Form 9A. Scale 1:2

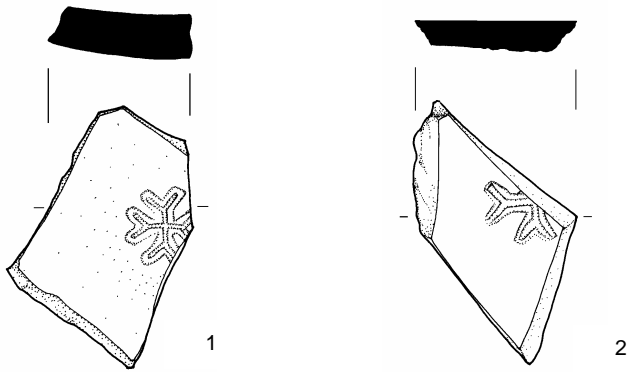

Figure 43 Cypriot Red Slip ware Form 9B. Scale 1:2

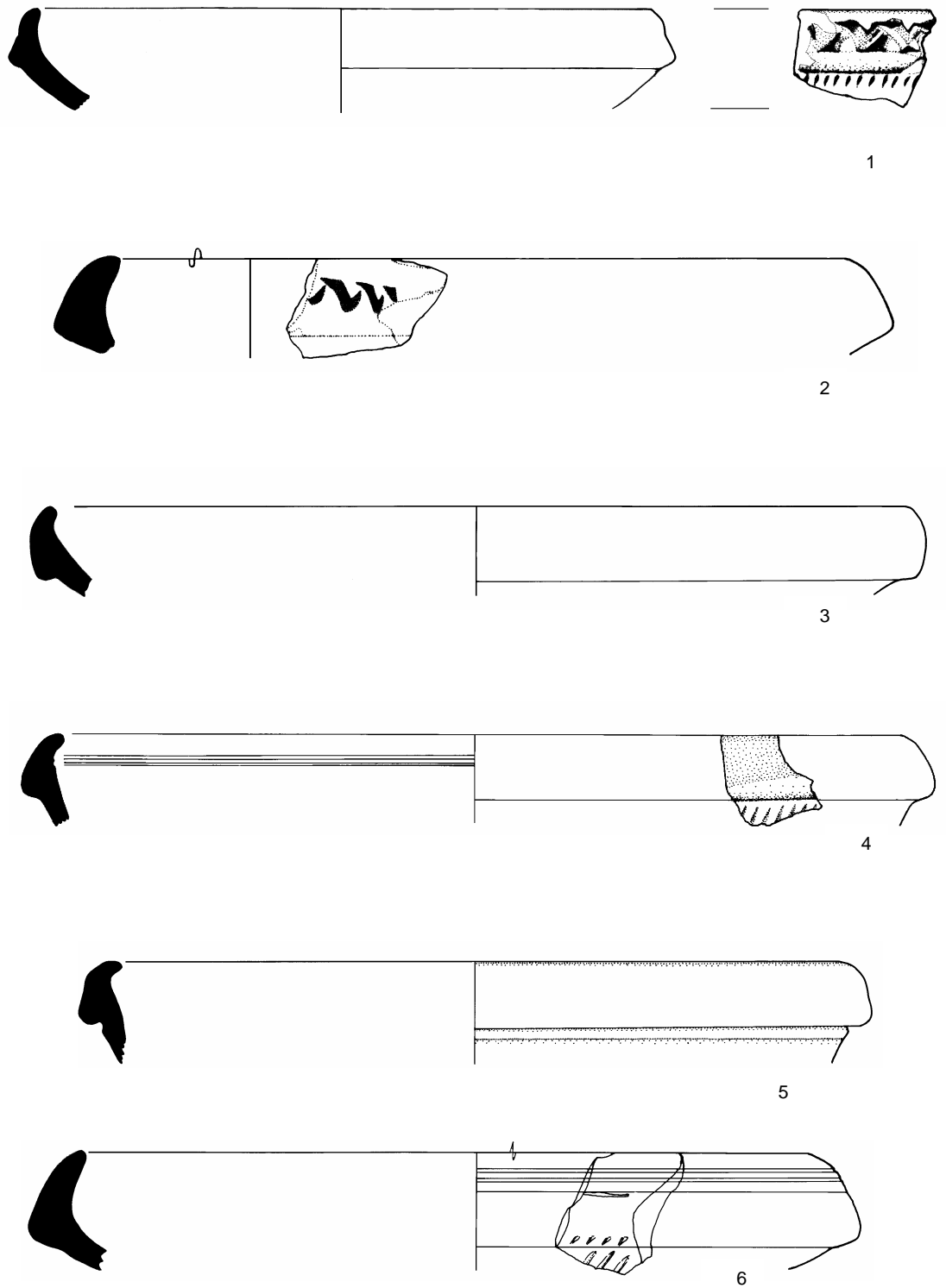

Figure 44 Cyriot Red Slip ware Form 9B. Scale 1:2

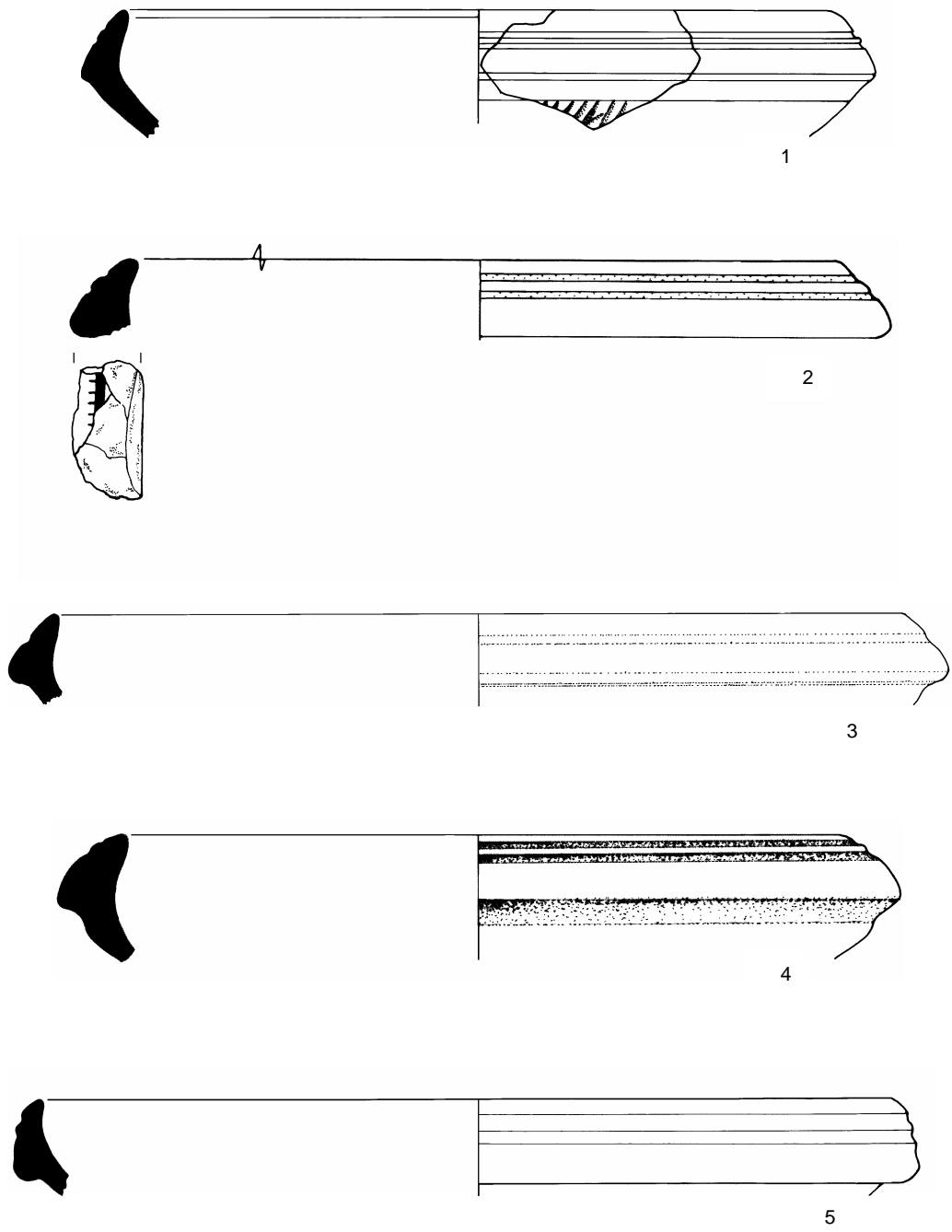

Figure 45 Cypriot Red Slip ware Form 9C.
Scale 1:2

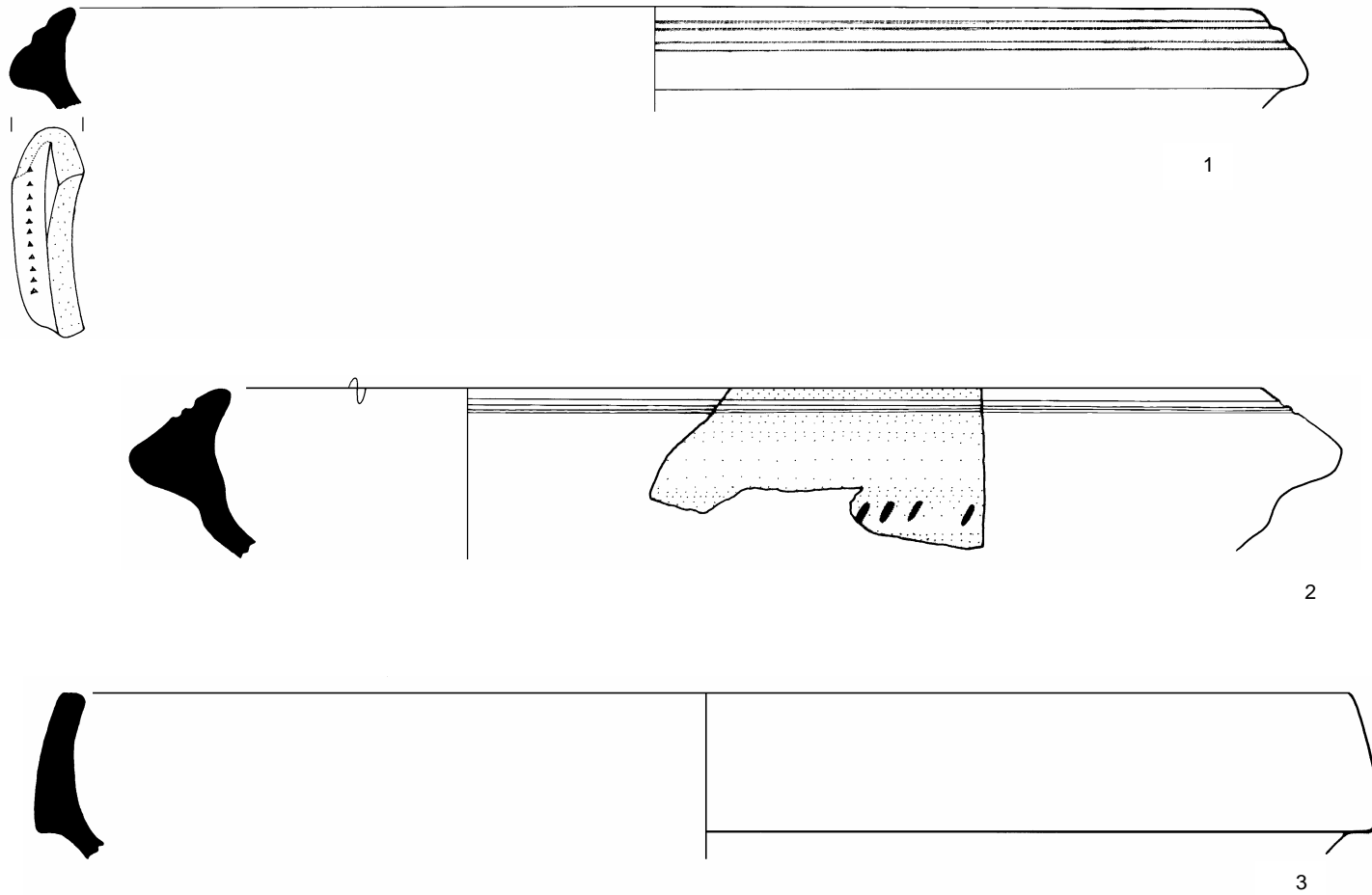

Figure 46 Cyproit Red Slip ware Form 10. Scale 1:2

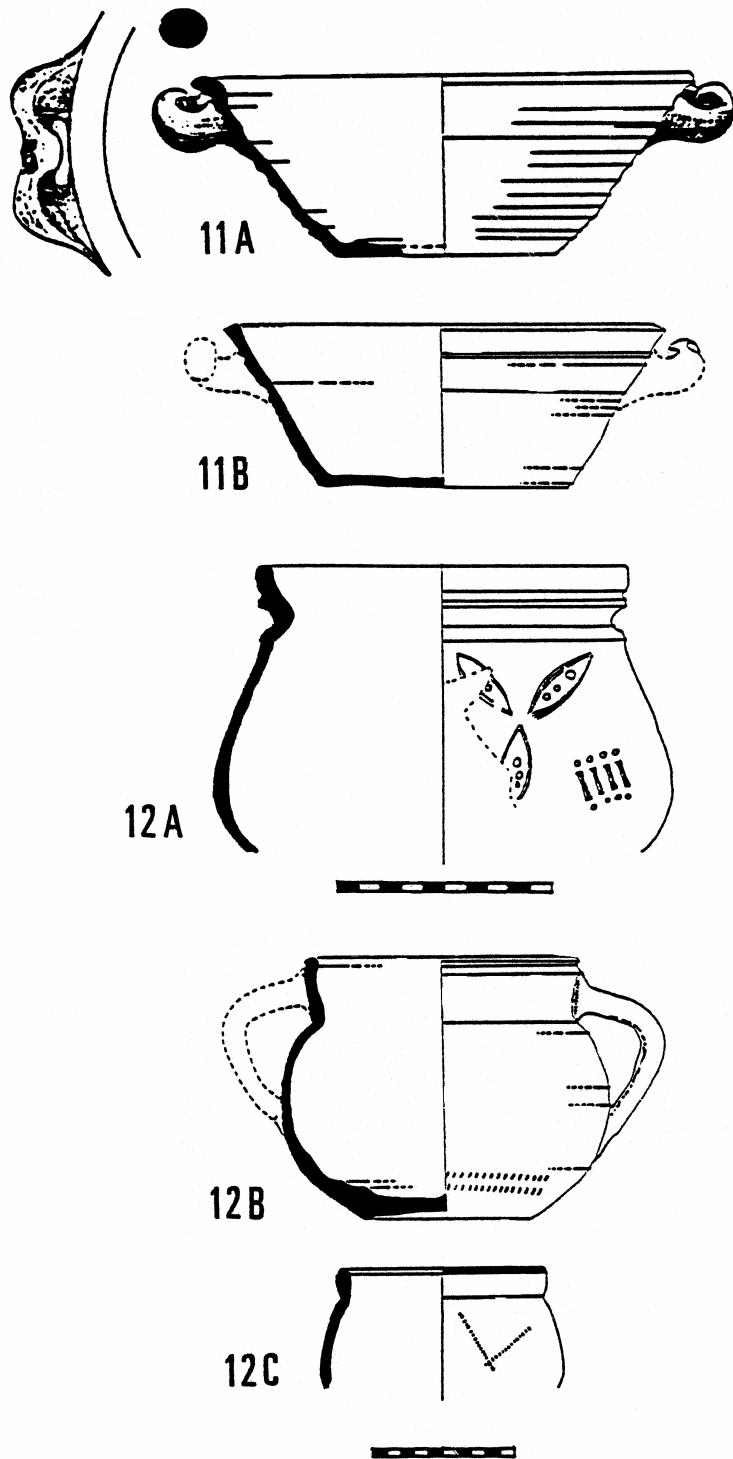

Figure 47 Revised typology for Cypriot Red Slip ware Part 4
(Source; Meyza, 2000)

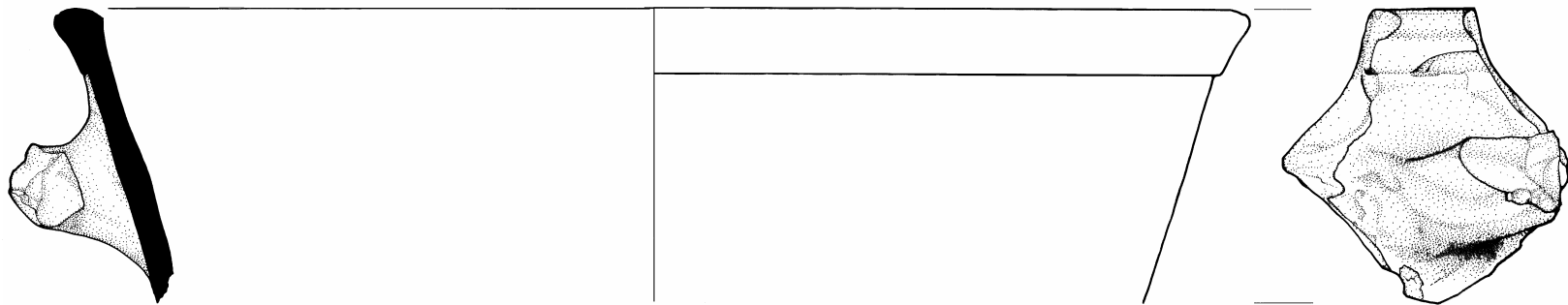

Figure 48 Cypriot Red Slip ware Form 11. Scale 1:2

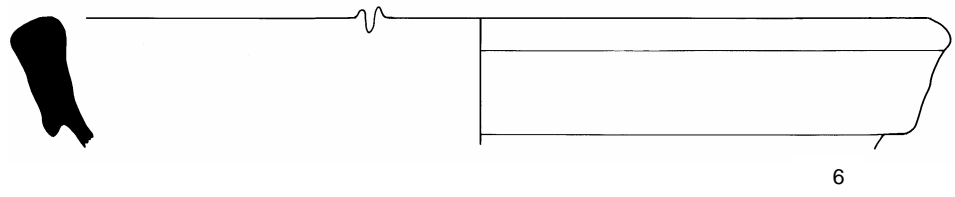
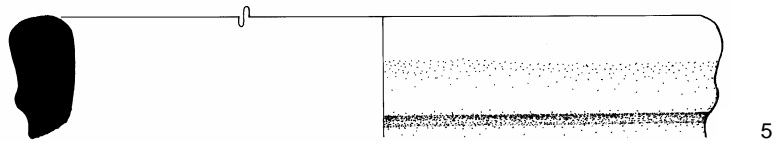
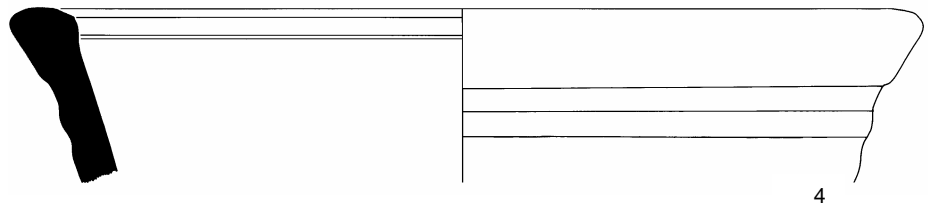
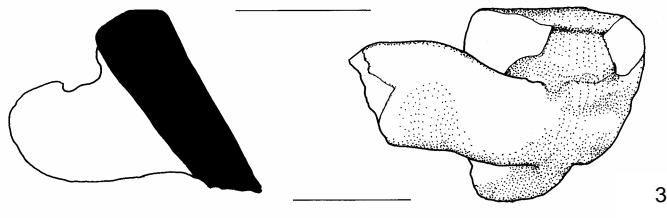
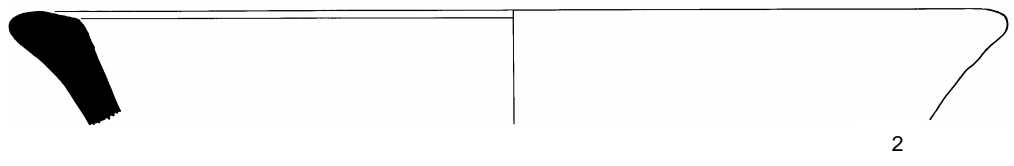
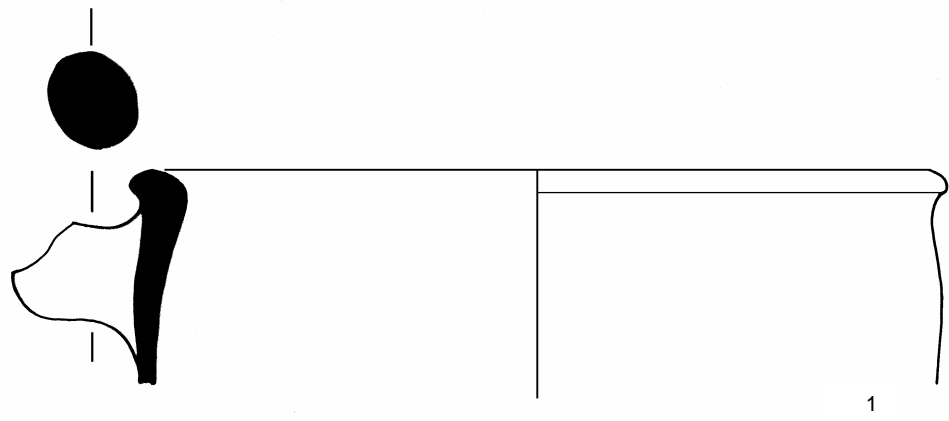
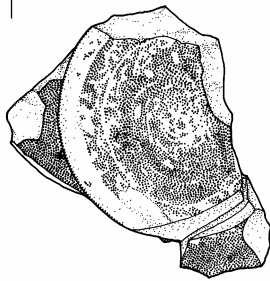
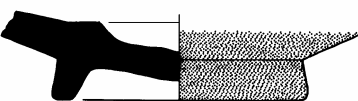
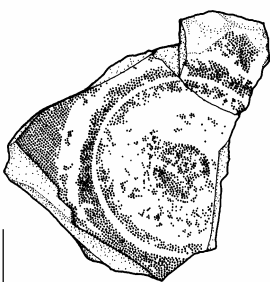

Figure 49 Cypriot Red Slip ware Form 11. Scale 1:2



1



2

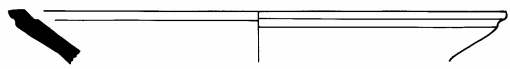

3

Figure 50 Black-glaze ware. Scale 1:2

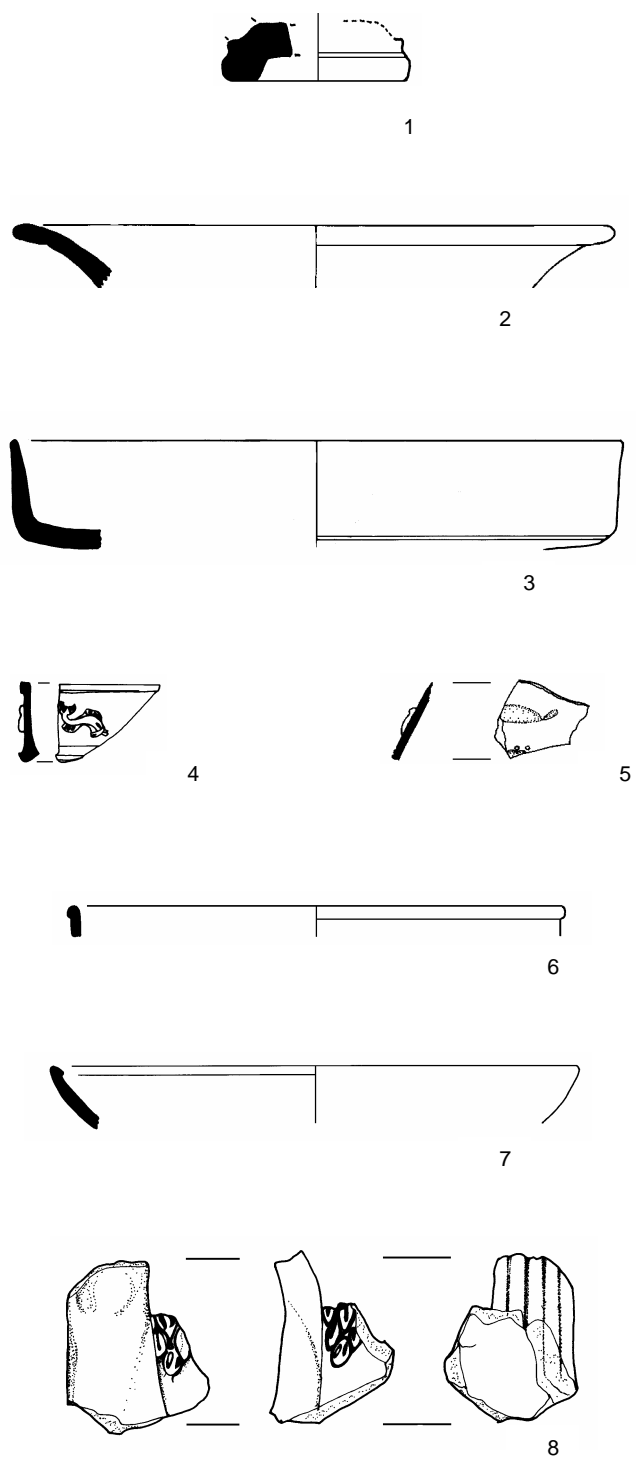

Figure 51 Eastern Sigillata A and Terra Sigillata. Scale 1:2

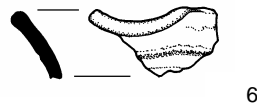
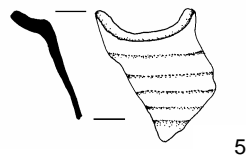
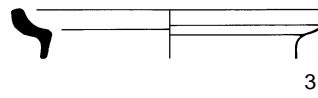
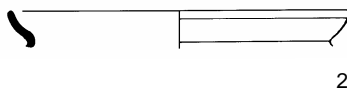
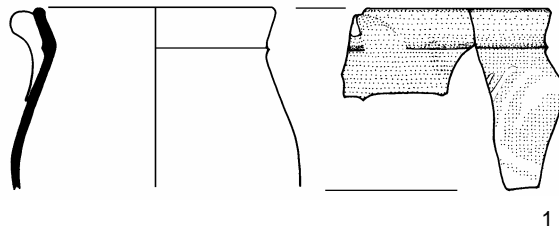

Figure 52 Thin-walled ware. Scale 1:2

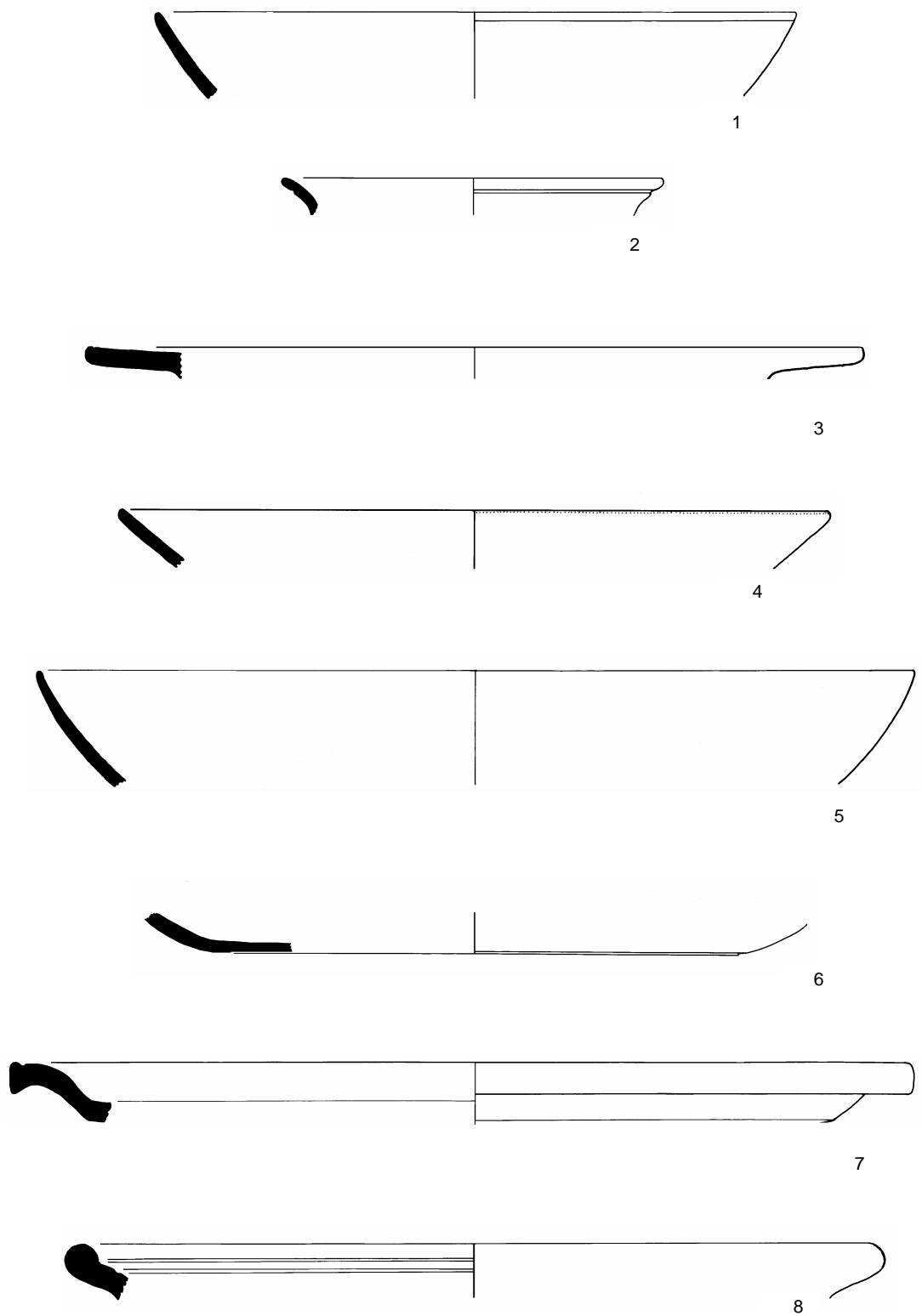
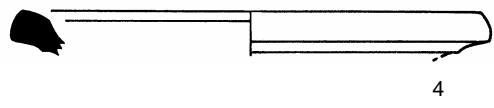
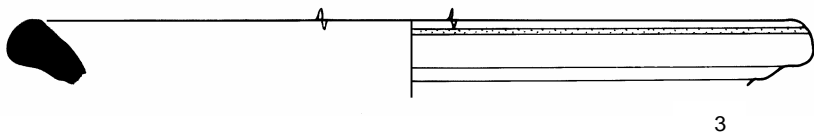
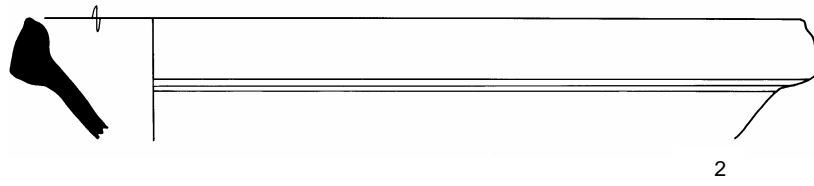
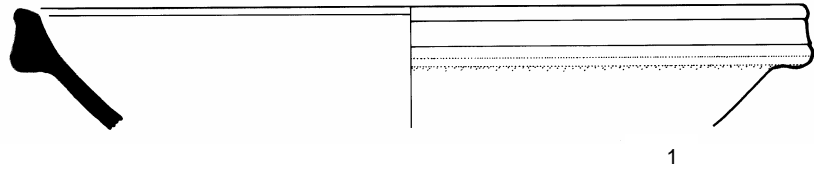

Figure 53 African Red Slip ware. Scale 1:2



2:5

Figure 54 "Phocaeen" Red Slip ware. Scale 1:2

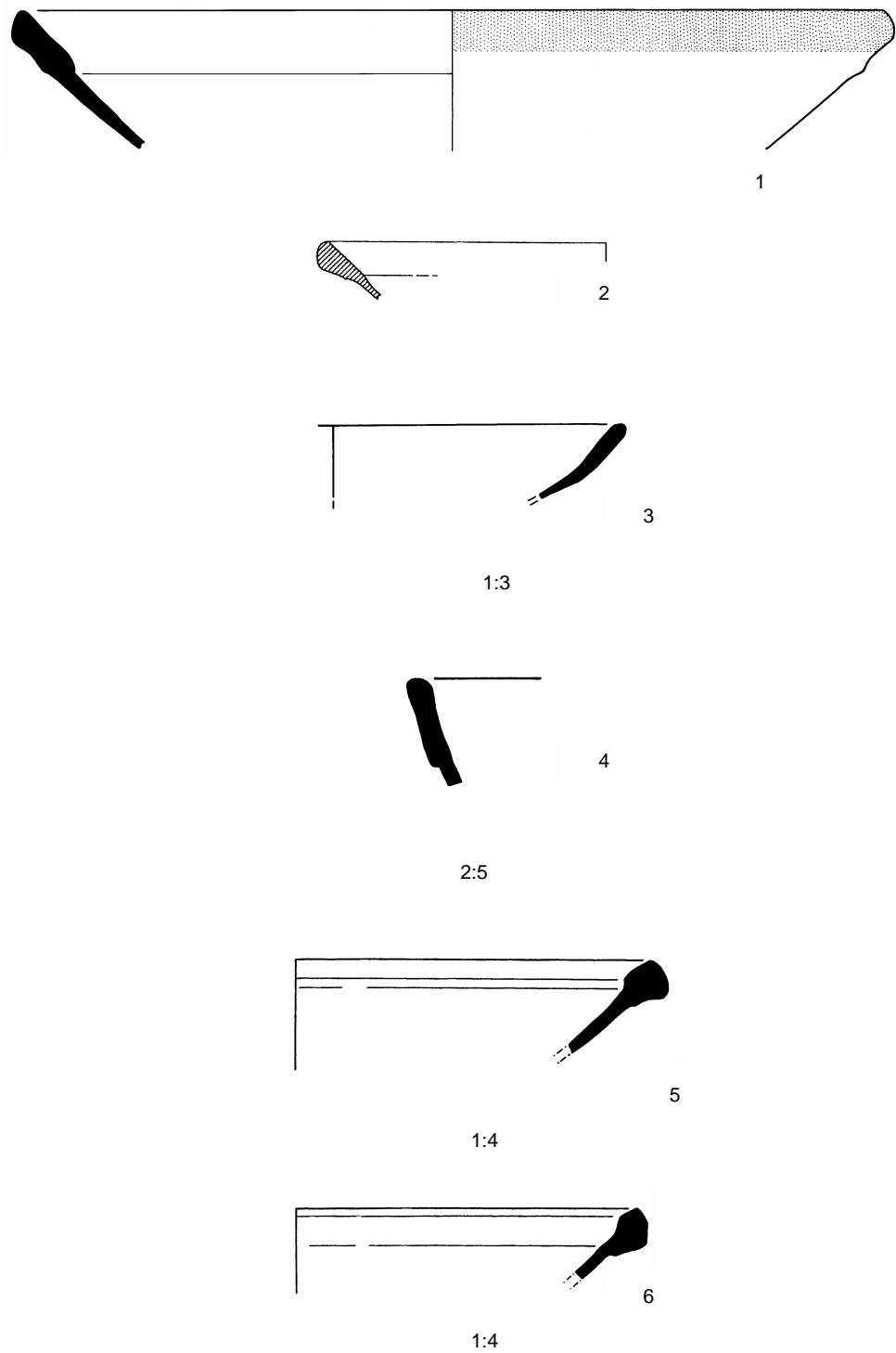

Figure 55 "Phocaean" Red Slip ware. Scale 1:2

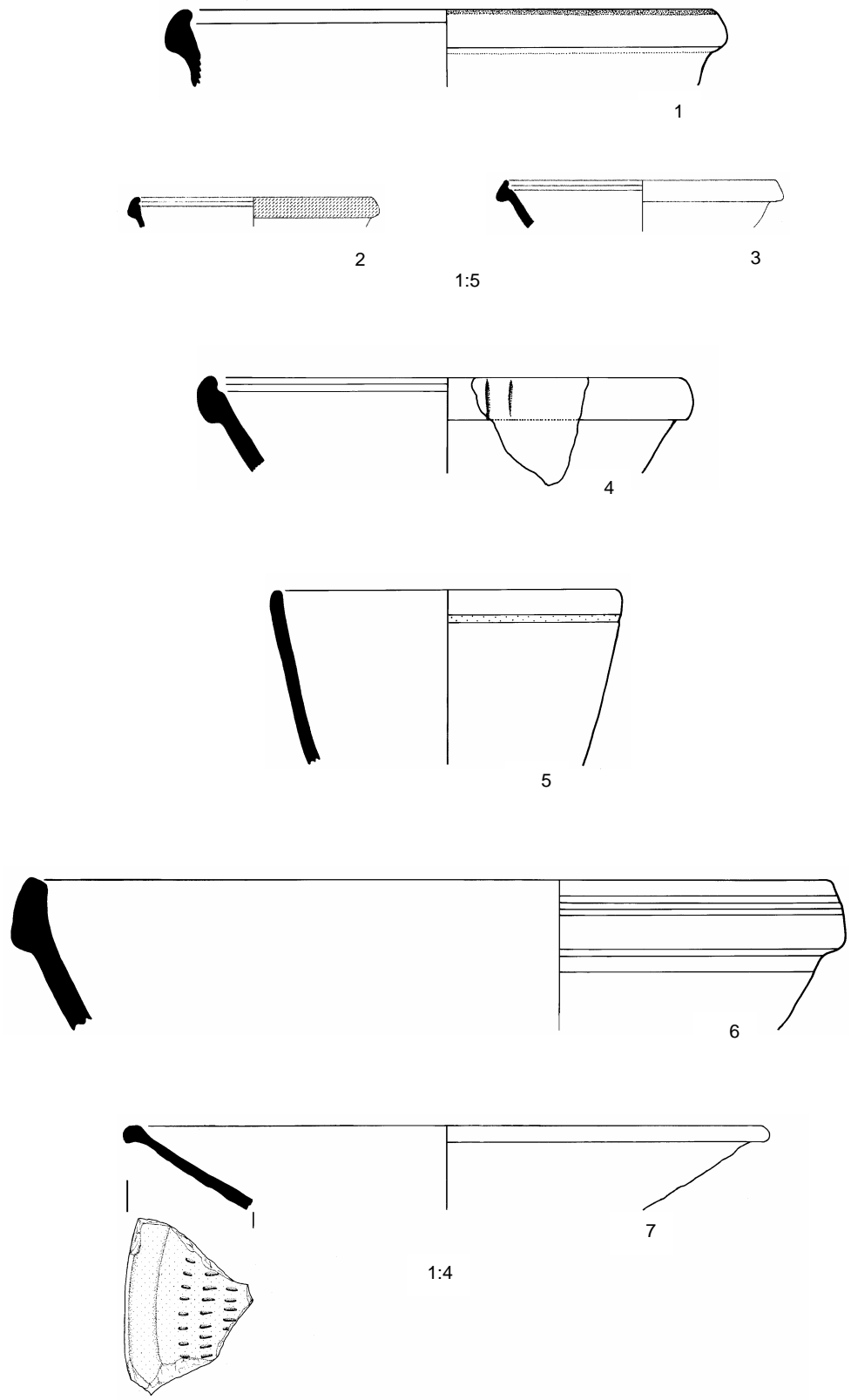

Figure 56 Egyptian Red Slip A ware. Scale 1:2

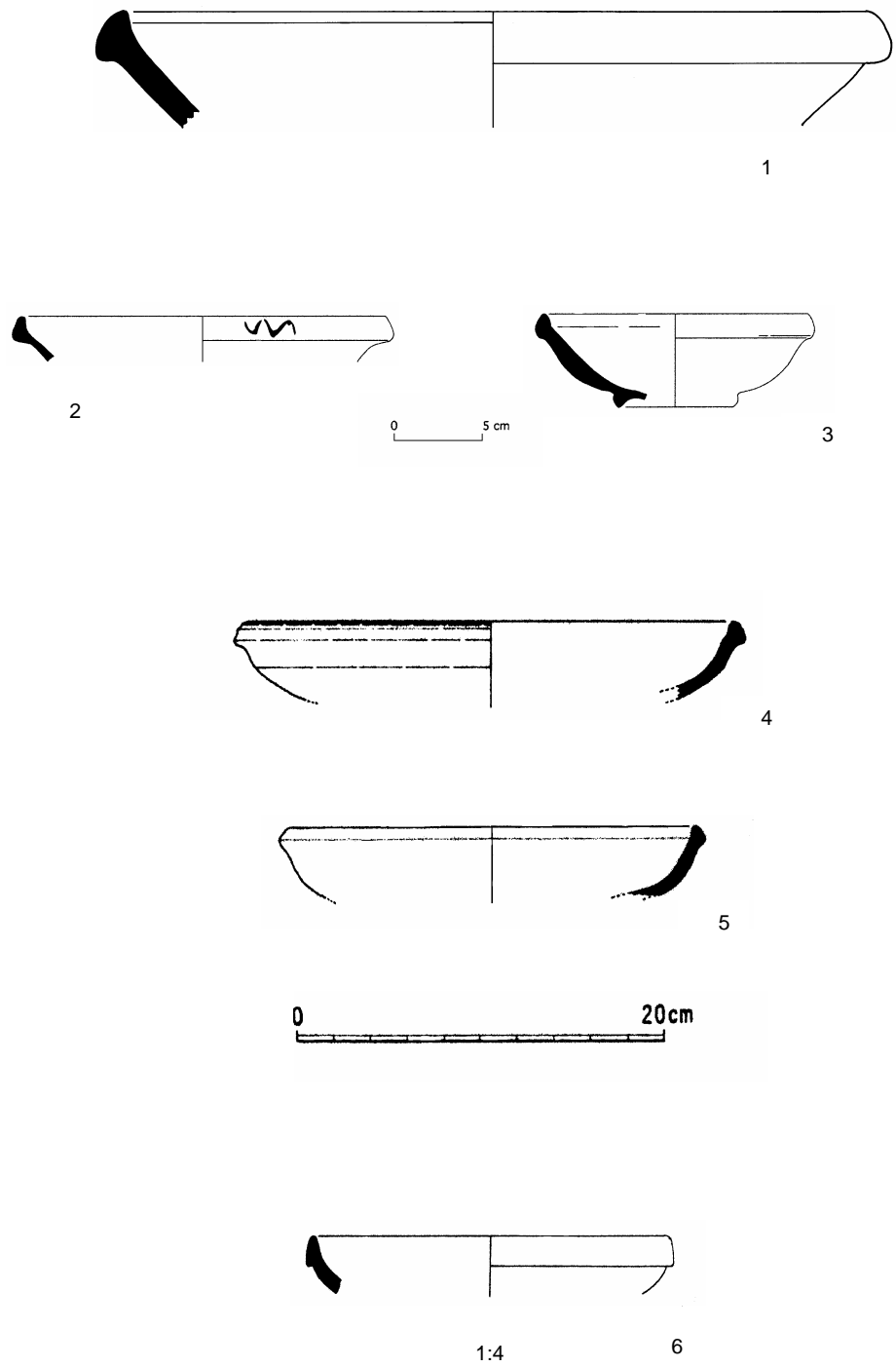

Figure 57 Egyptian Red Slip B ware. Scale 1:2

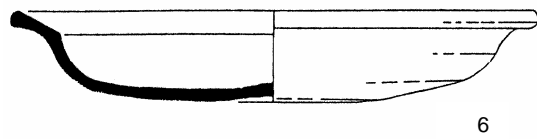
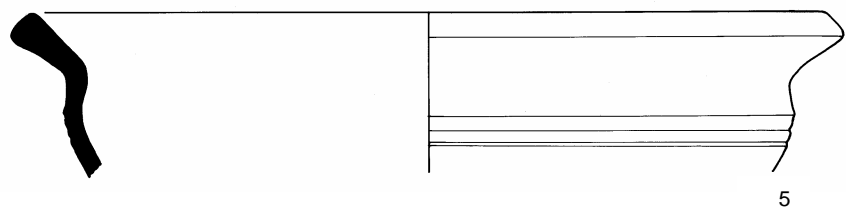
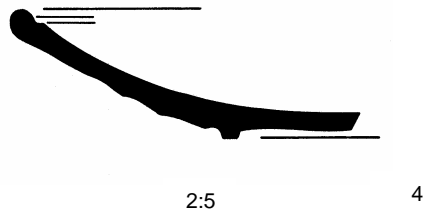
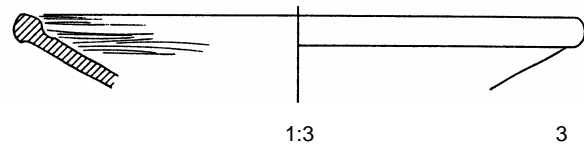
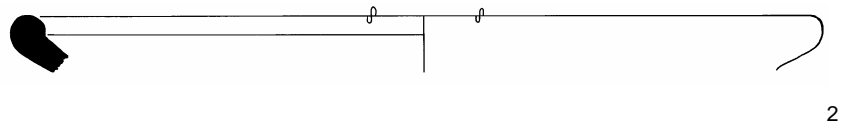
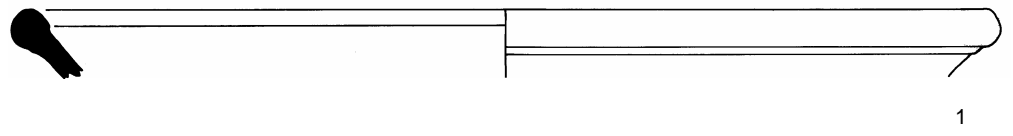

Figure 58 Egyptian Red Slip B ware. Scale 1:2

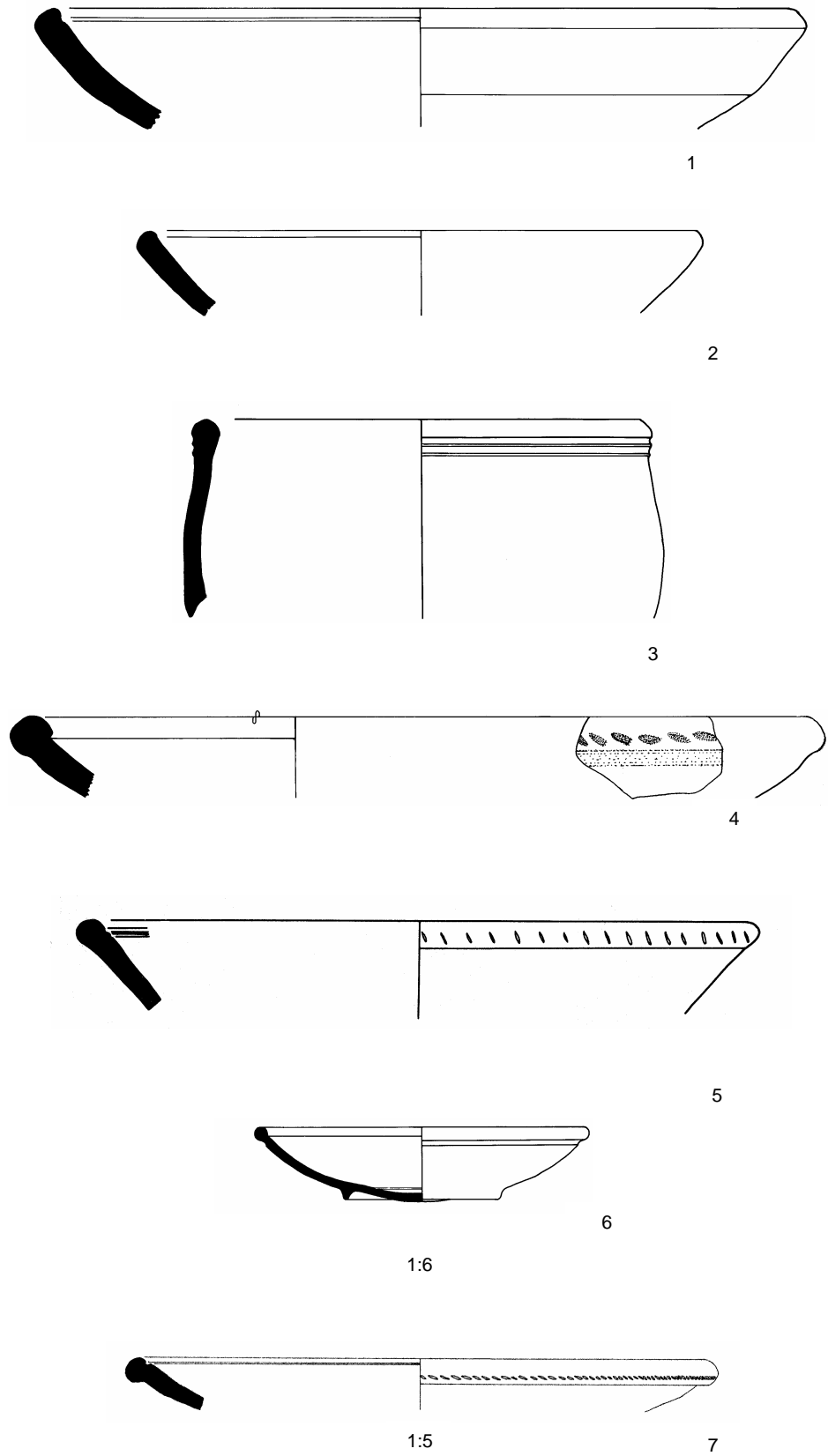

Figure 59 Egyptian Red Slip C ware. Scale 1:2

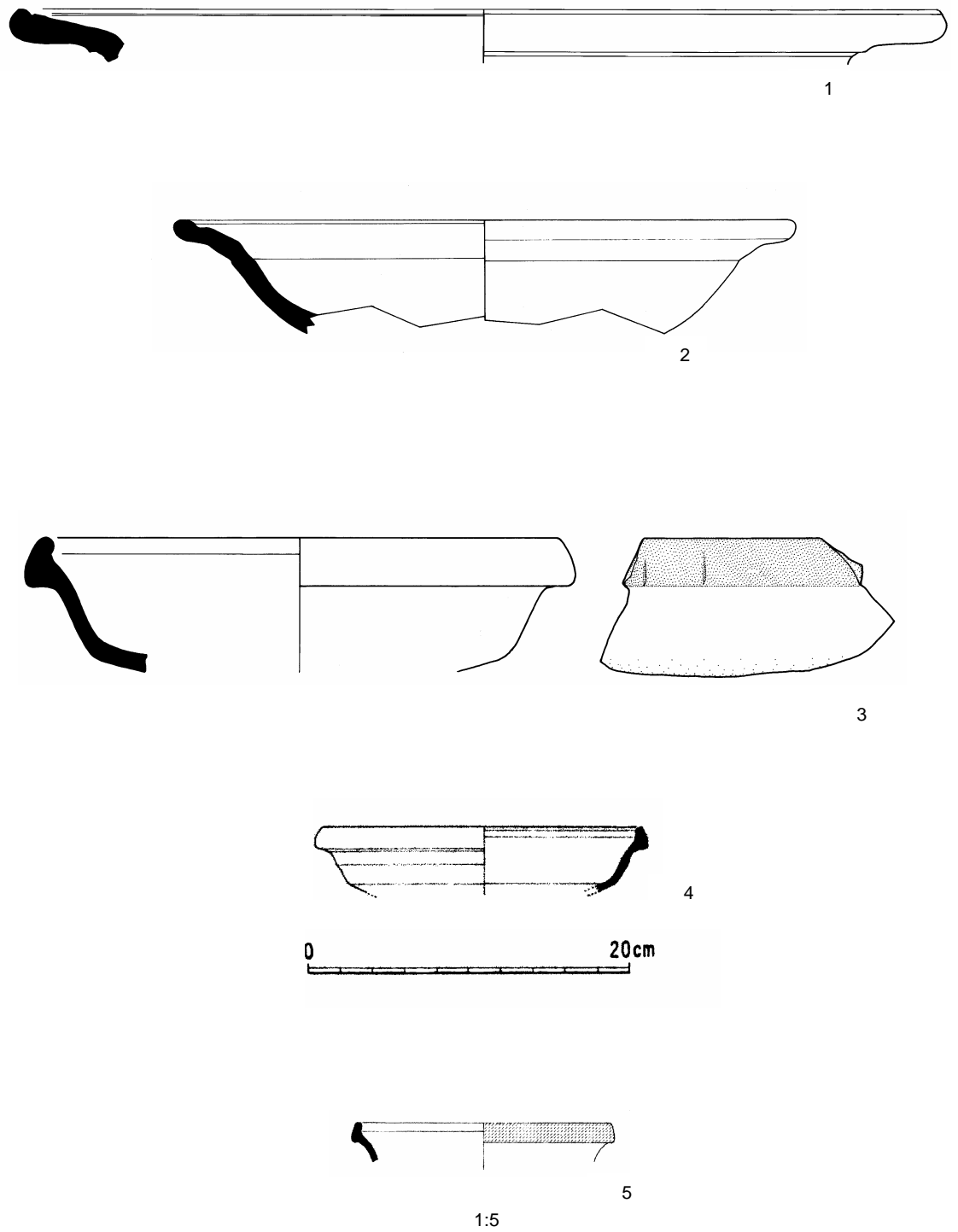

Figure 60 Egyptian Red Slip C ware. Scale 1:2

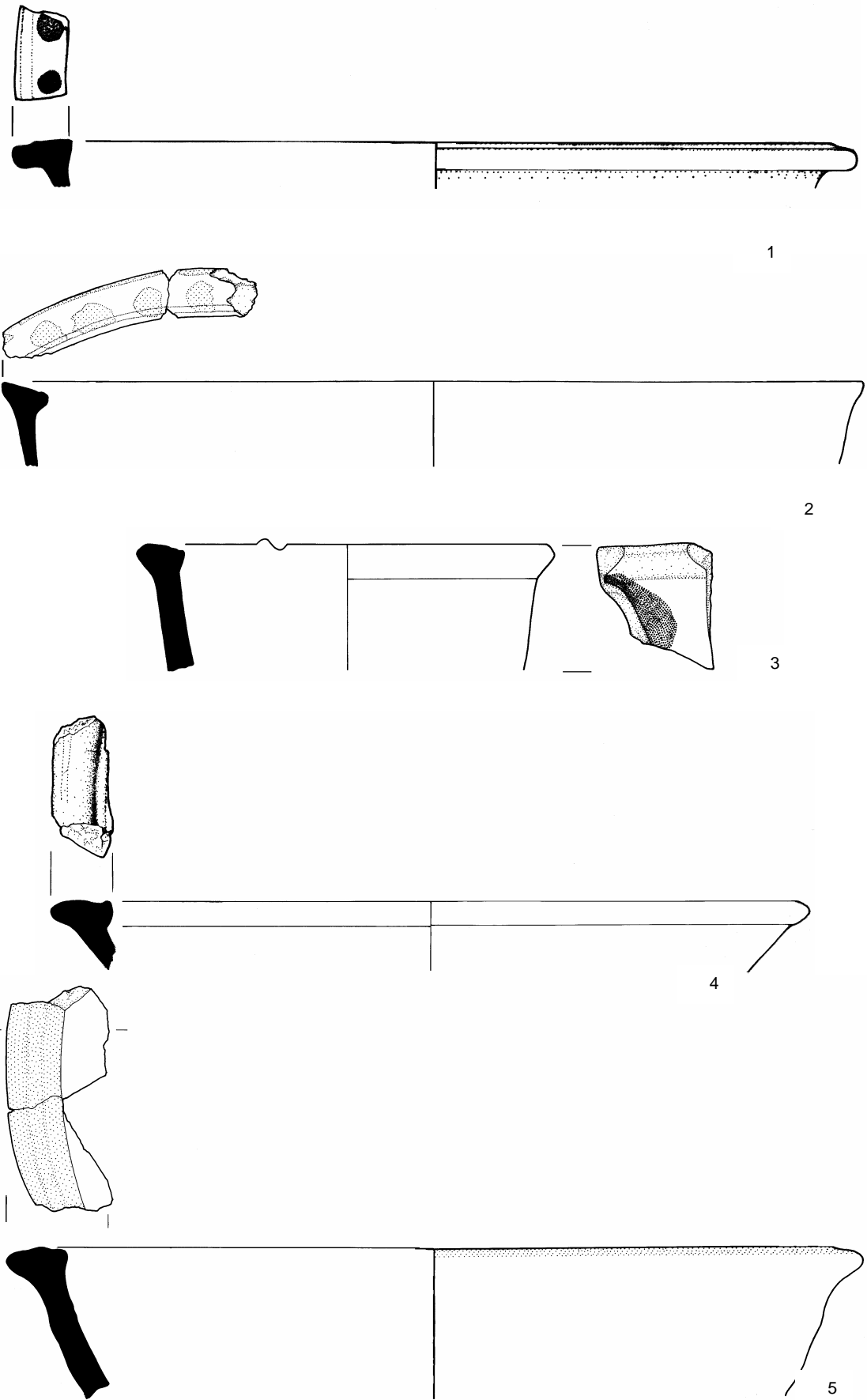

Figure 61 Egyptian Painted Basins. Scale 1:2

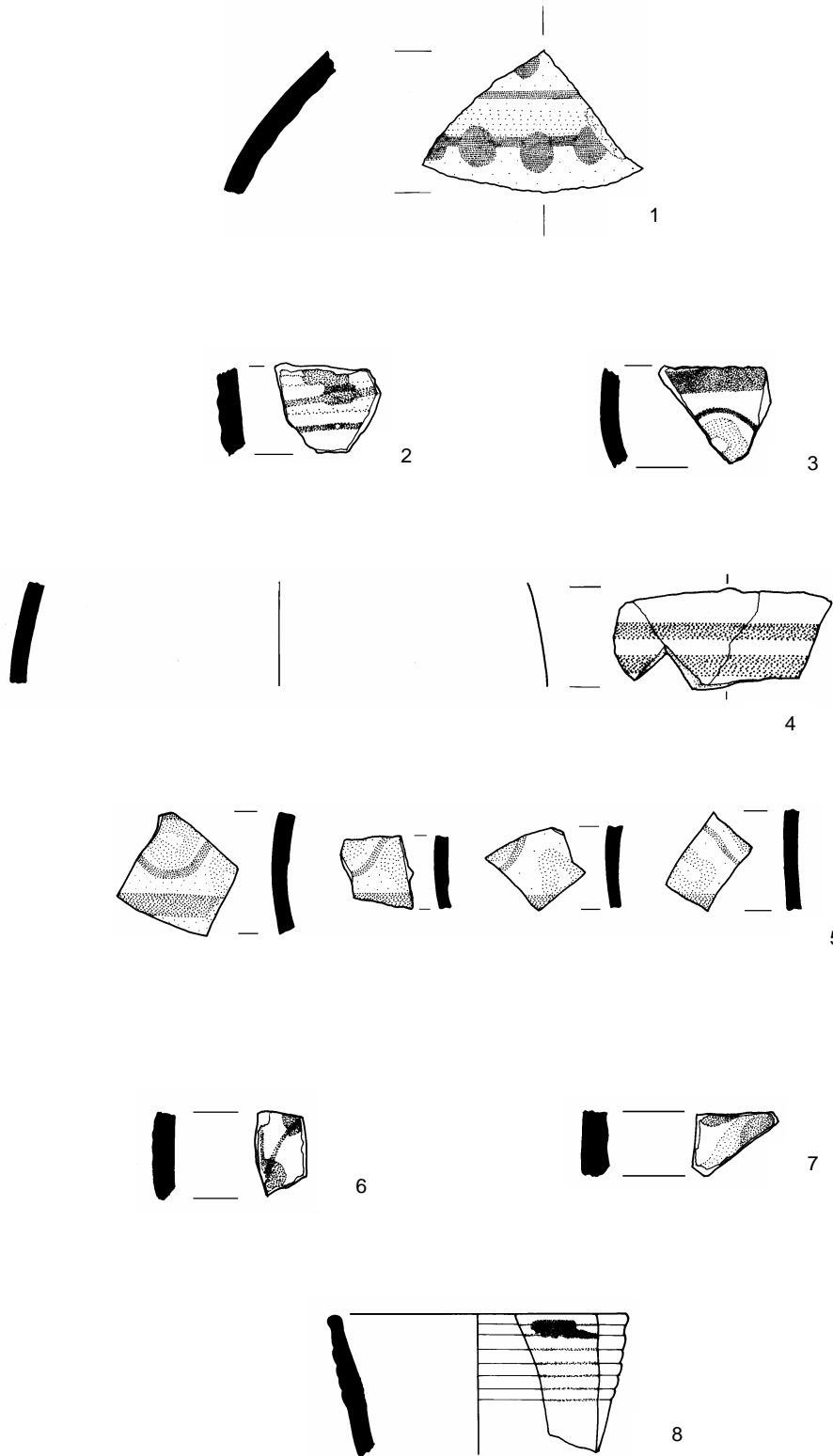
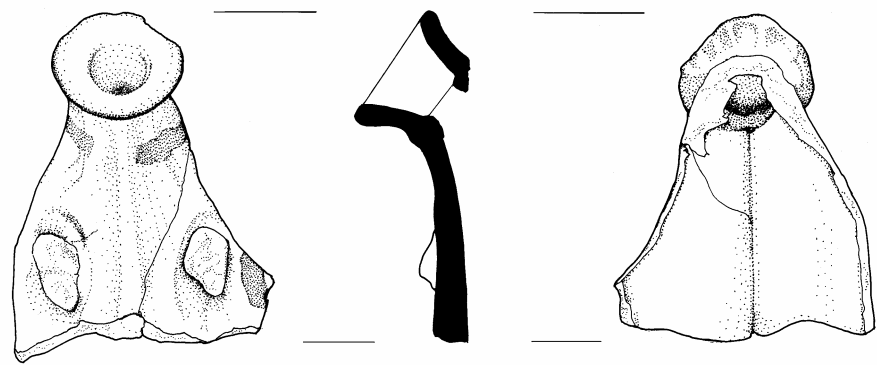

Figure 62 Egyptian Painted Jugs/Flagons. Scale 1:2



1



2



3

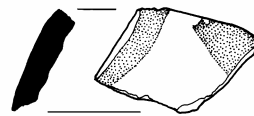

4

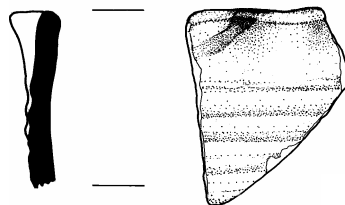

5

Figure 63 "Decorated Red ware". Scale 1:2

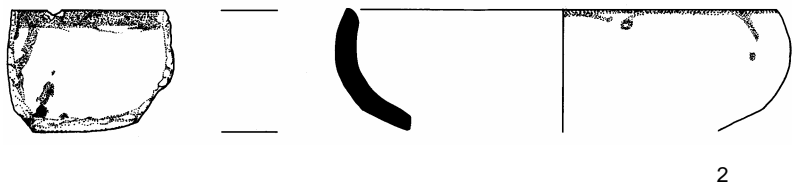
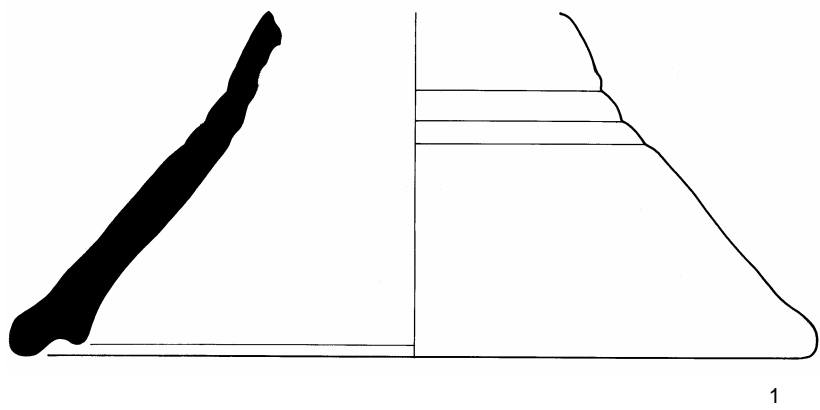
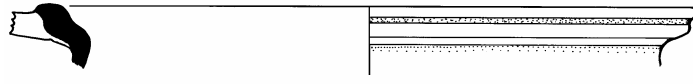
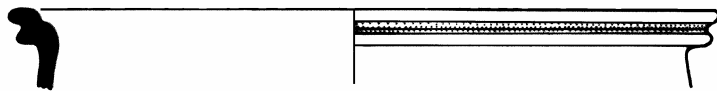

Figure 64 "Decorated Red ware". Scale 1:2



1



2

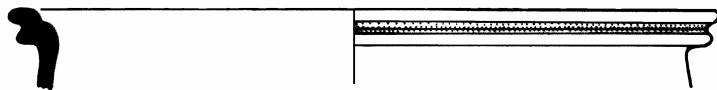

3

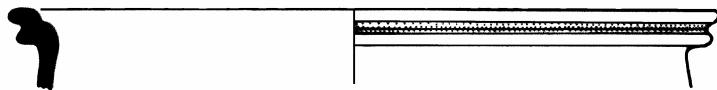

4

Figure 65 Early Roman Cooking Pots Type 1. Scale 1:2

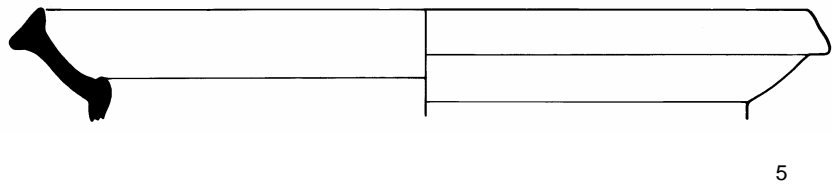
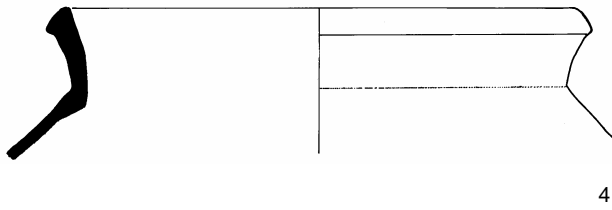
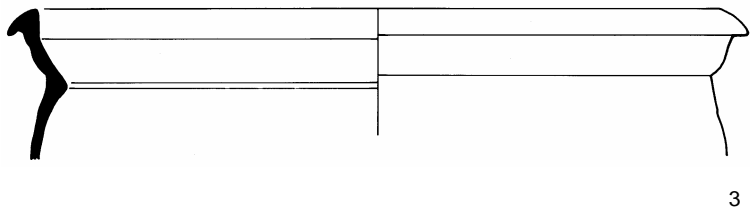
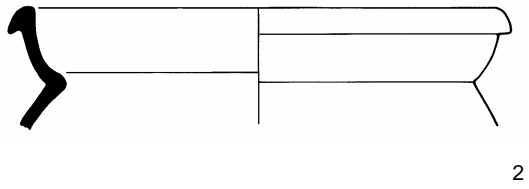
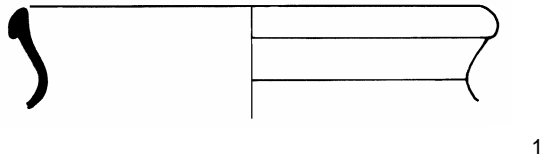

Figure 66 Early Roman Cooking Pots Type 2. Scale 1:2

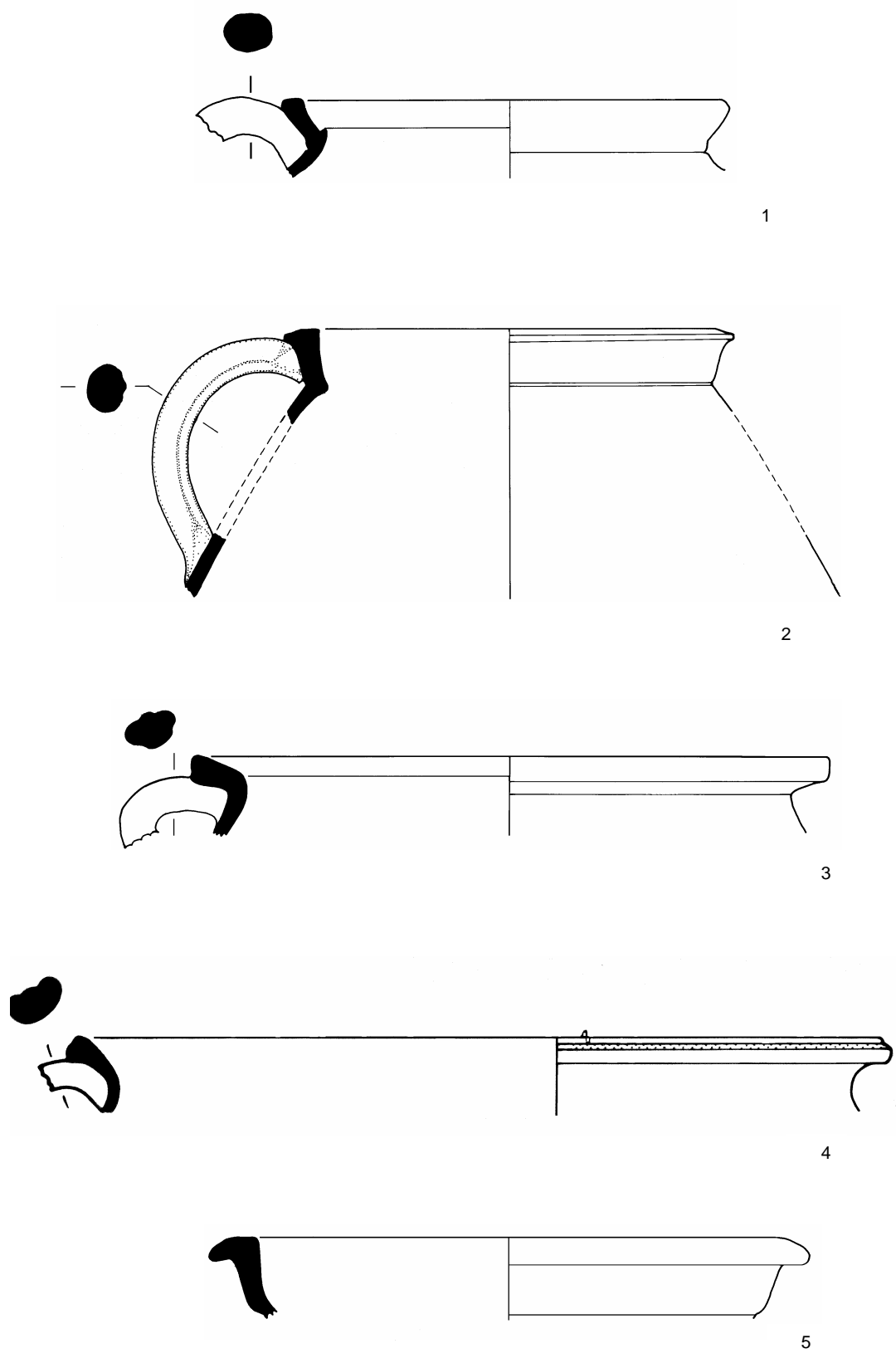

Figure 67 Early Roman Cooking Pots Type 3. Scale 1:2

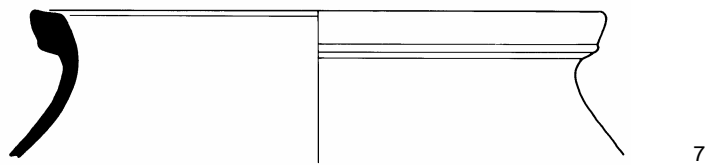
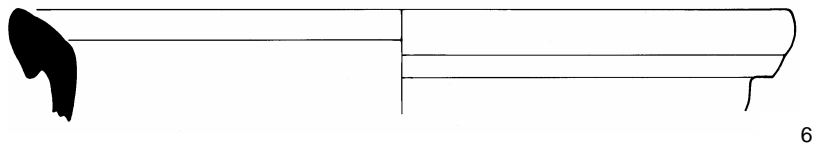
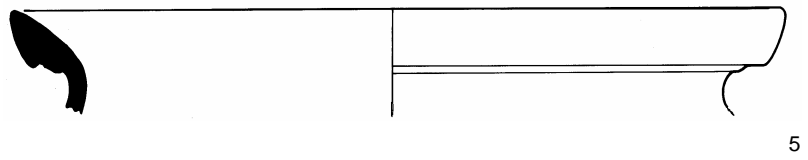
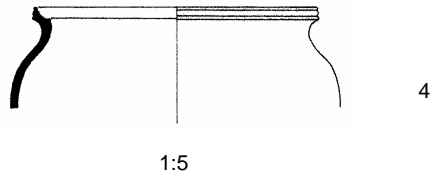
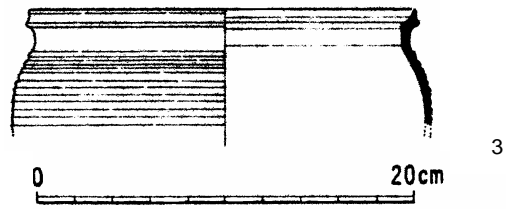
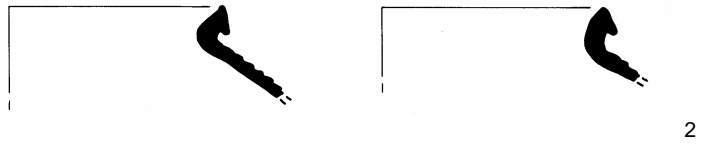
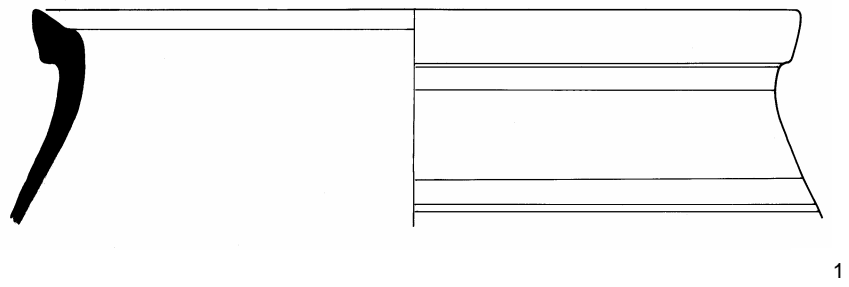

Figure 68 Fourth century Cooking Pots Type 1. Scale 1:2

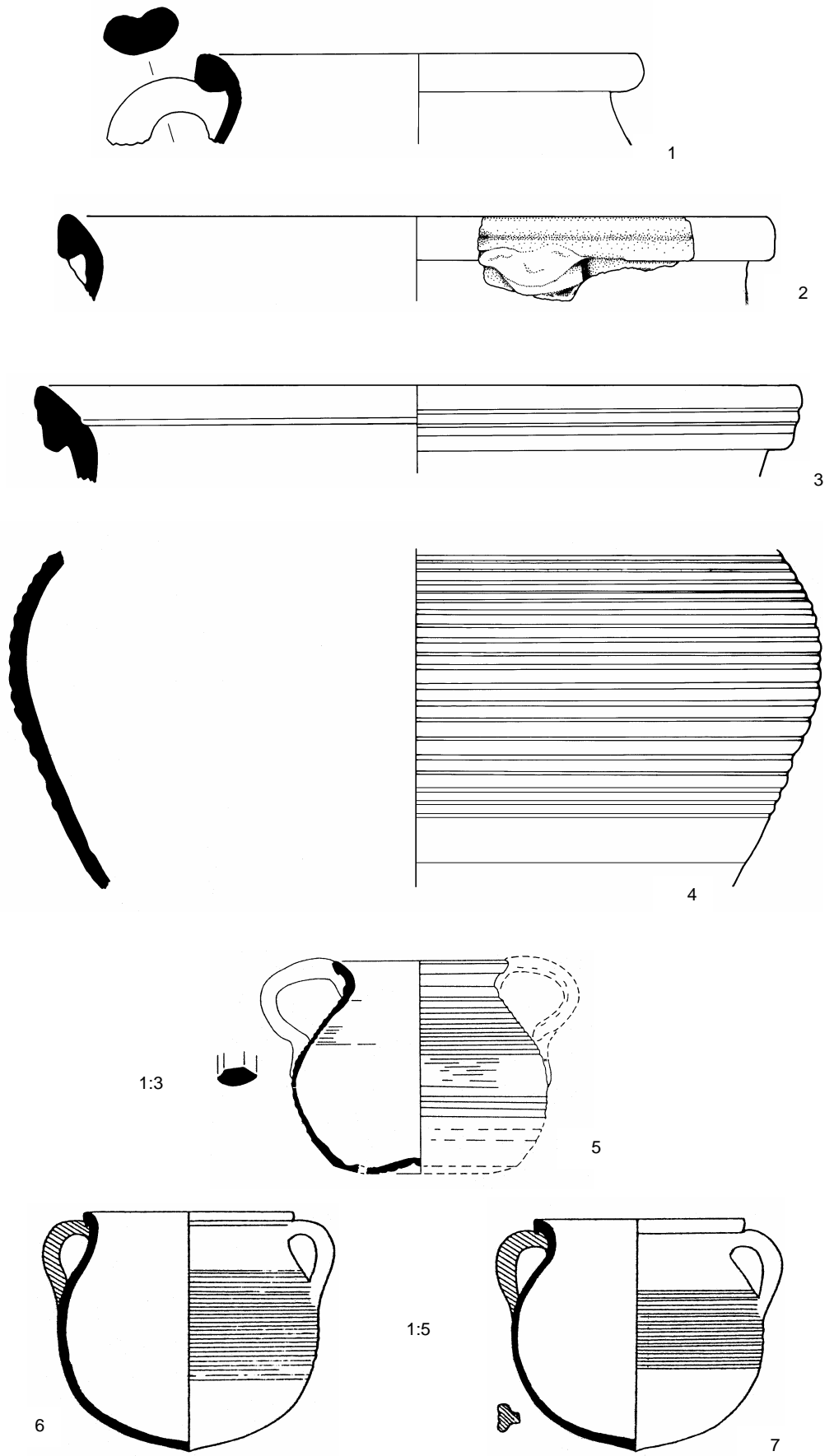

Figure 69 Fourth century Cooking Pots Type 1. Scale 1:2

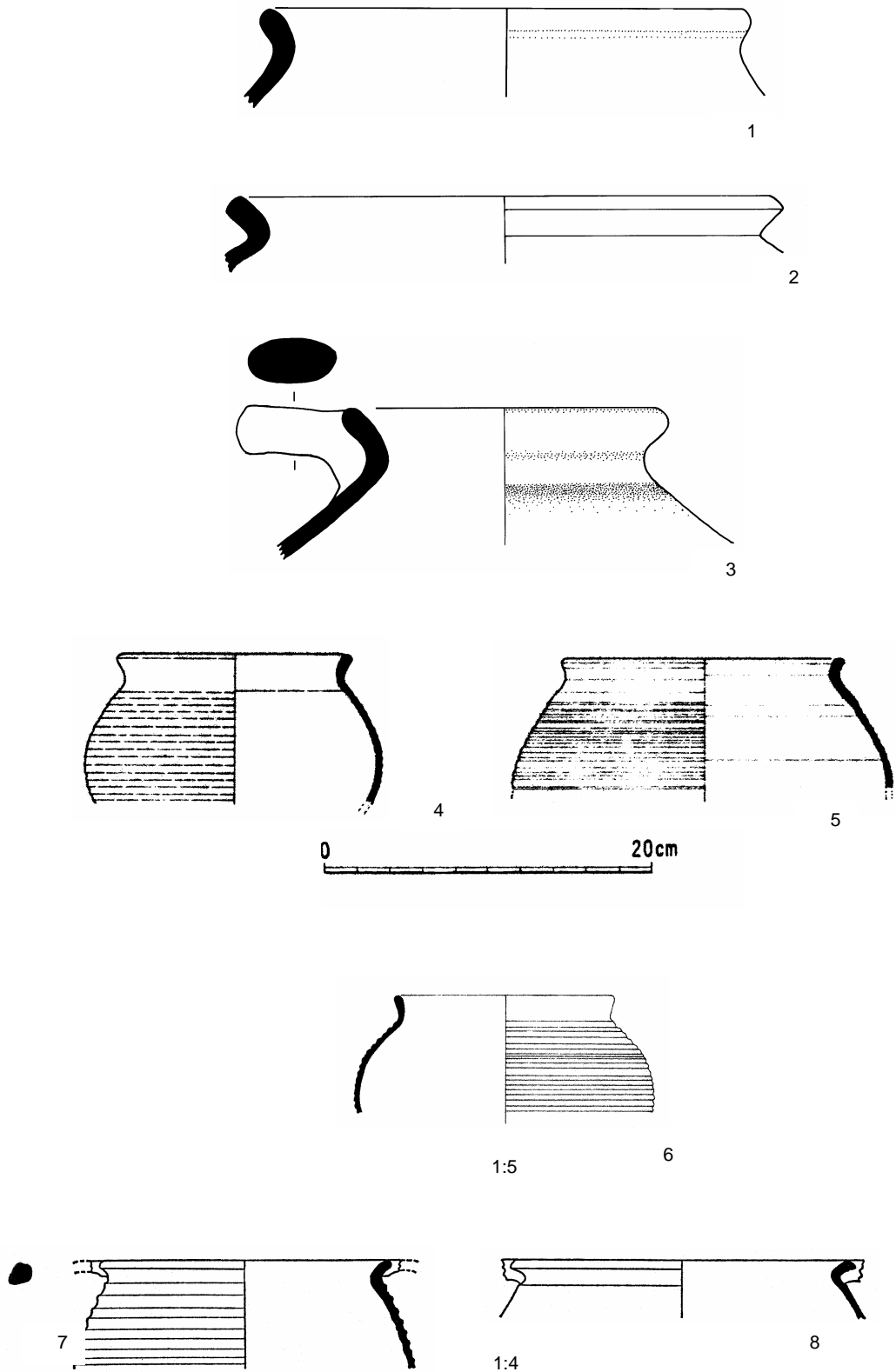

Figure 70 Fourth century Cooking Pots Type 2. Scale 1:2

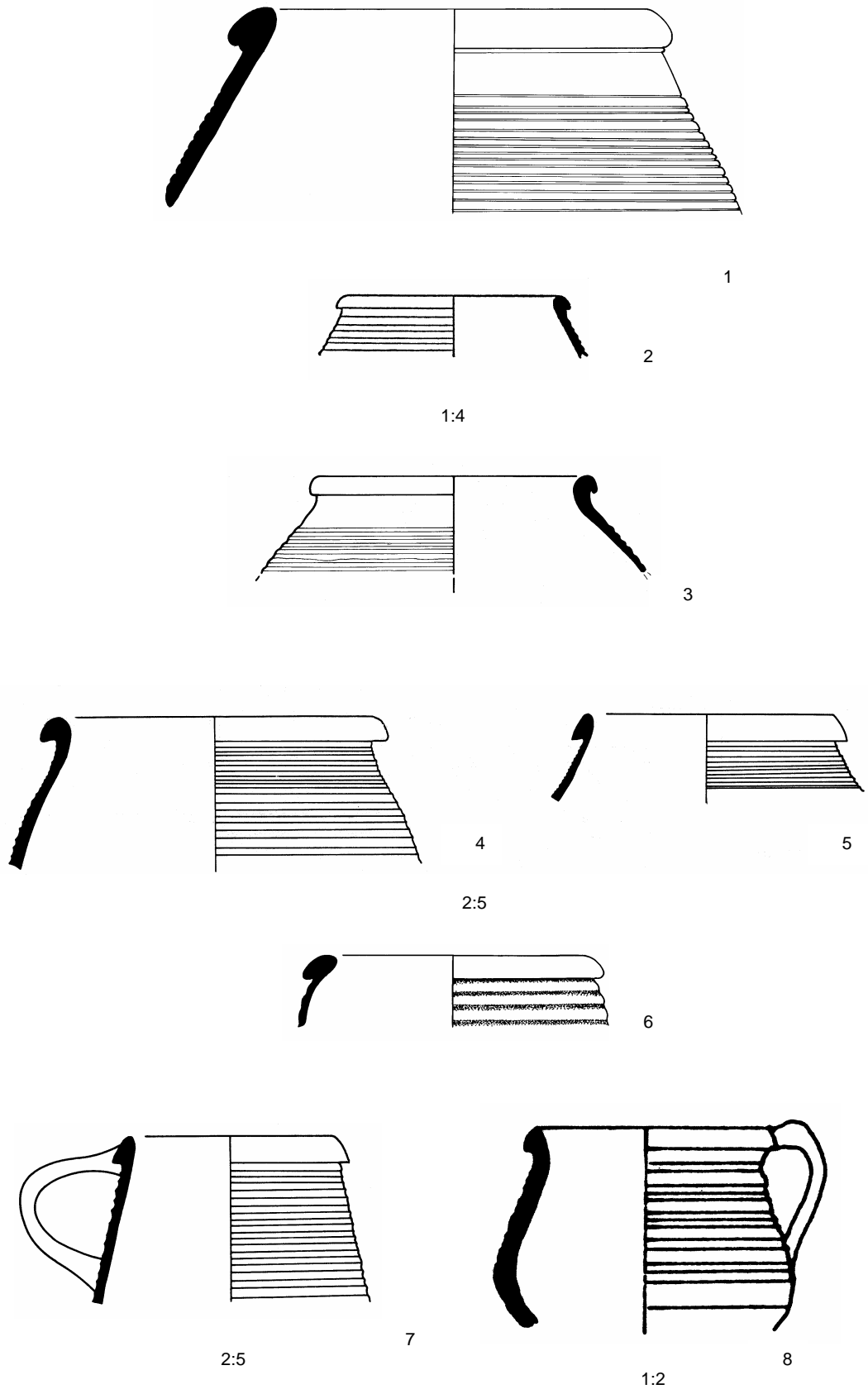

Figure 71 Fourth century Cooking Pots Type 3. Scale 1:2

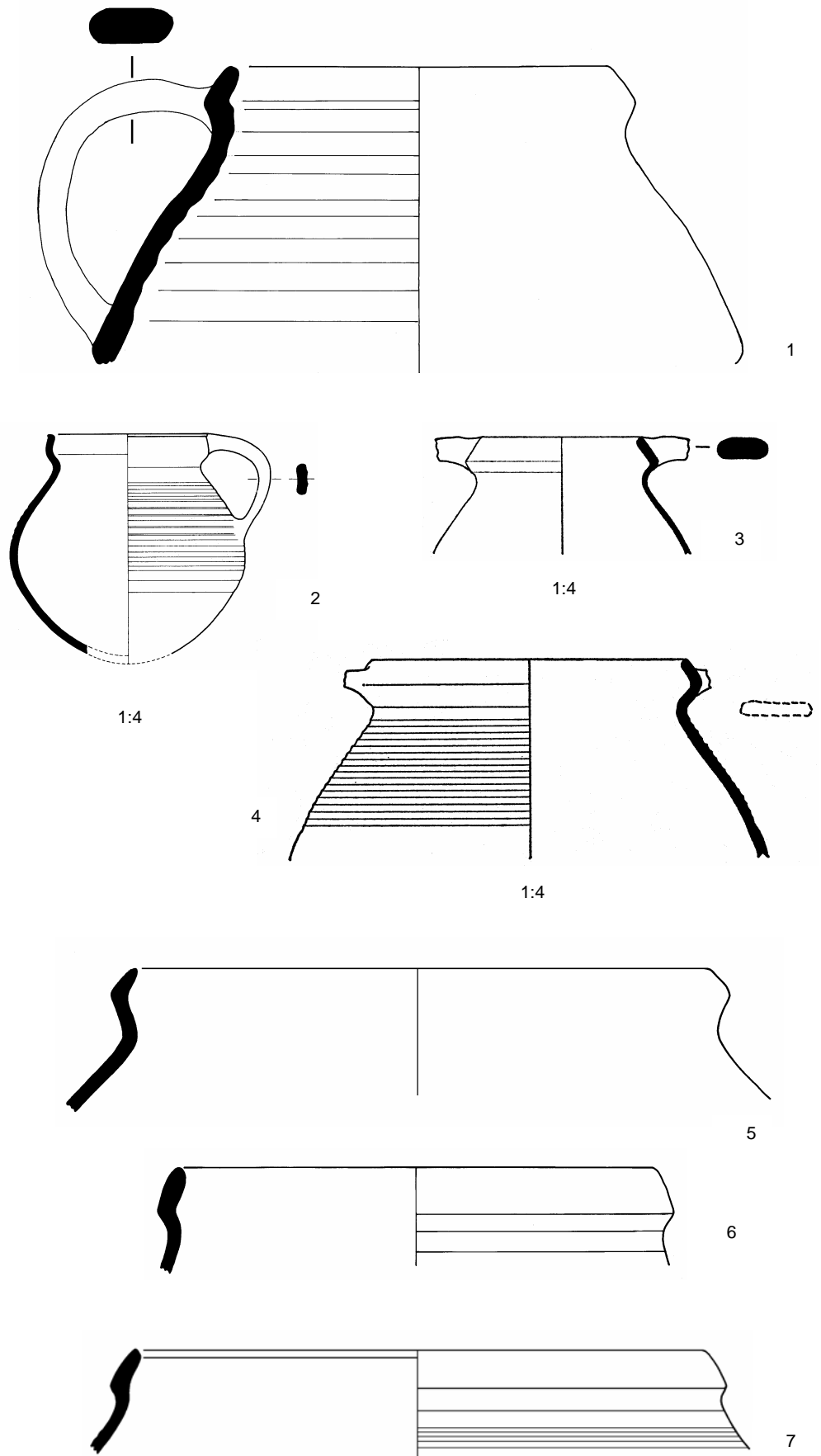

Figure 72 Fifth century and later Cooking pot types. Scale 1:2

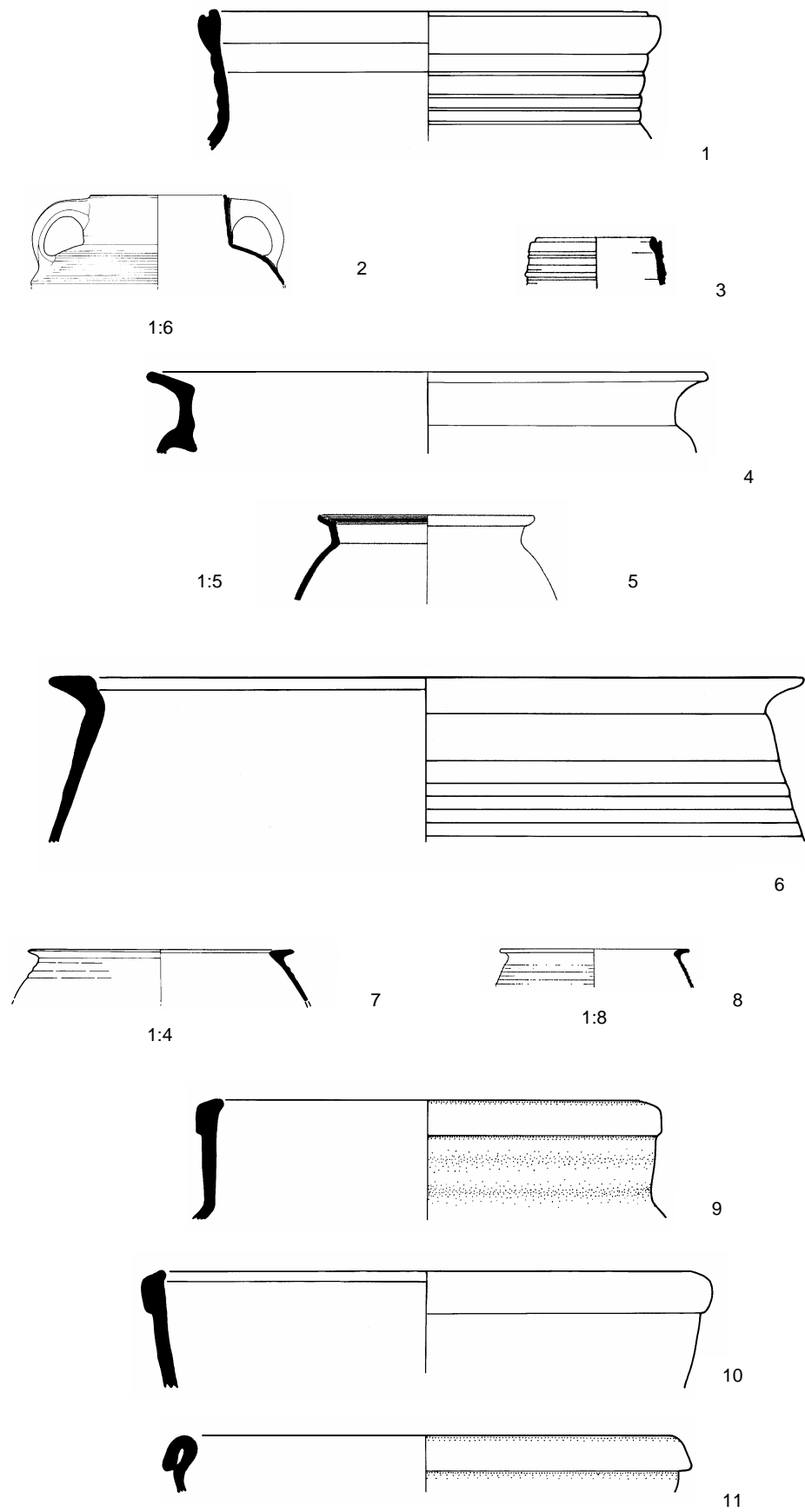

Figure 73 Imported Cooking pot types. Scale 1:2

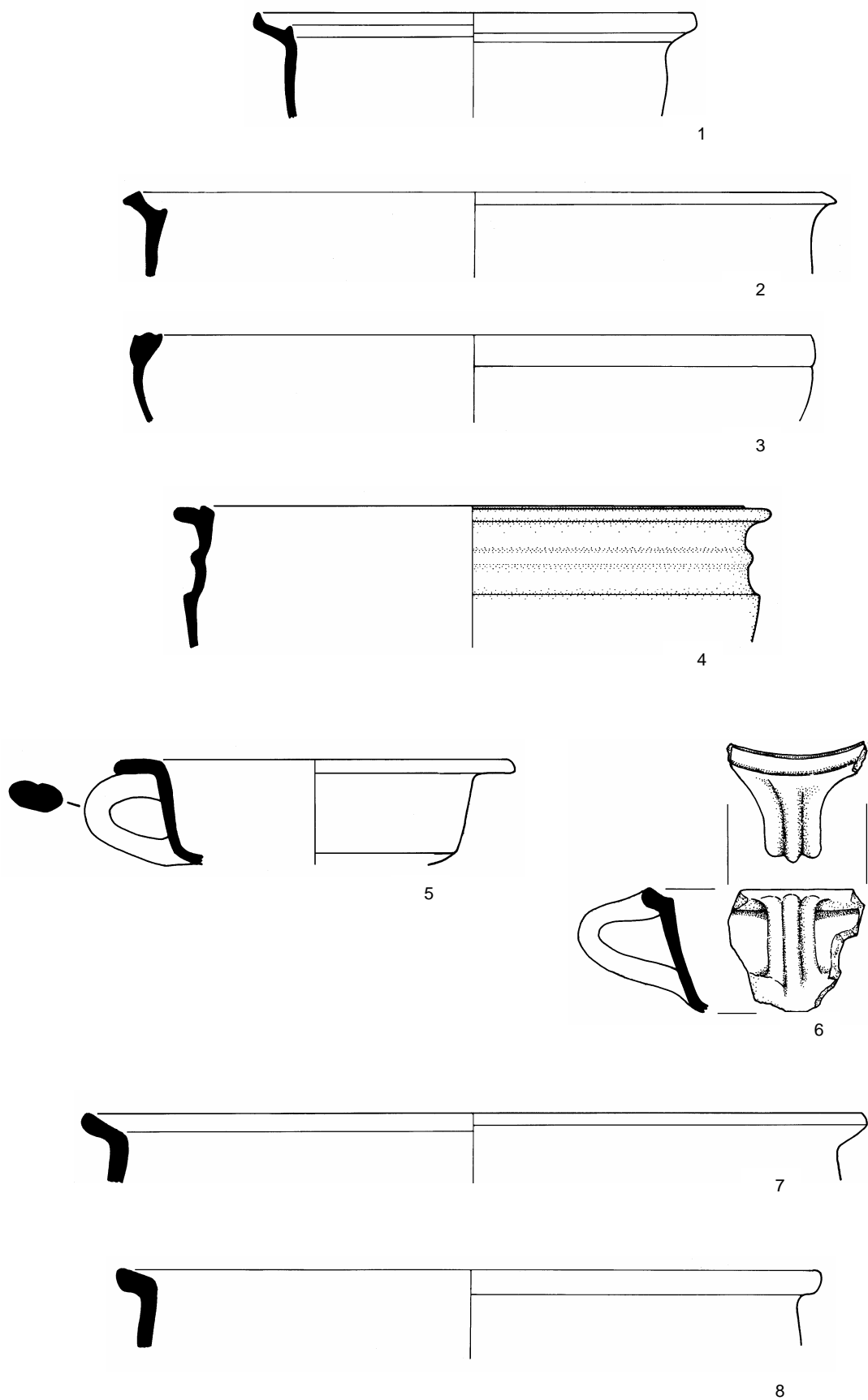

Figure 74 Early to Mid Roman Casserole types. Scale 1:2

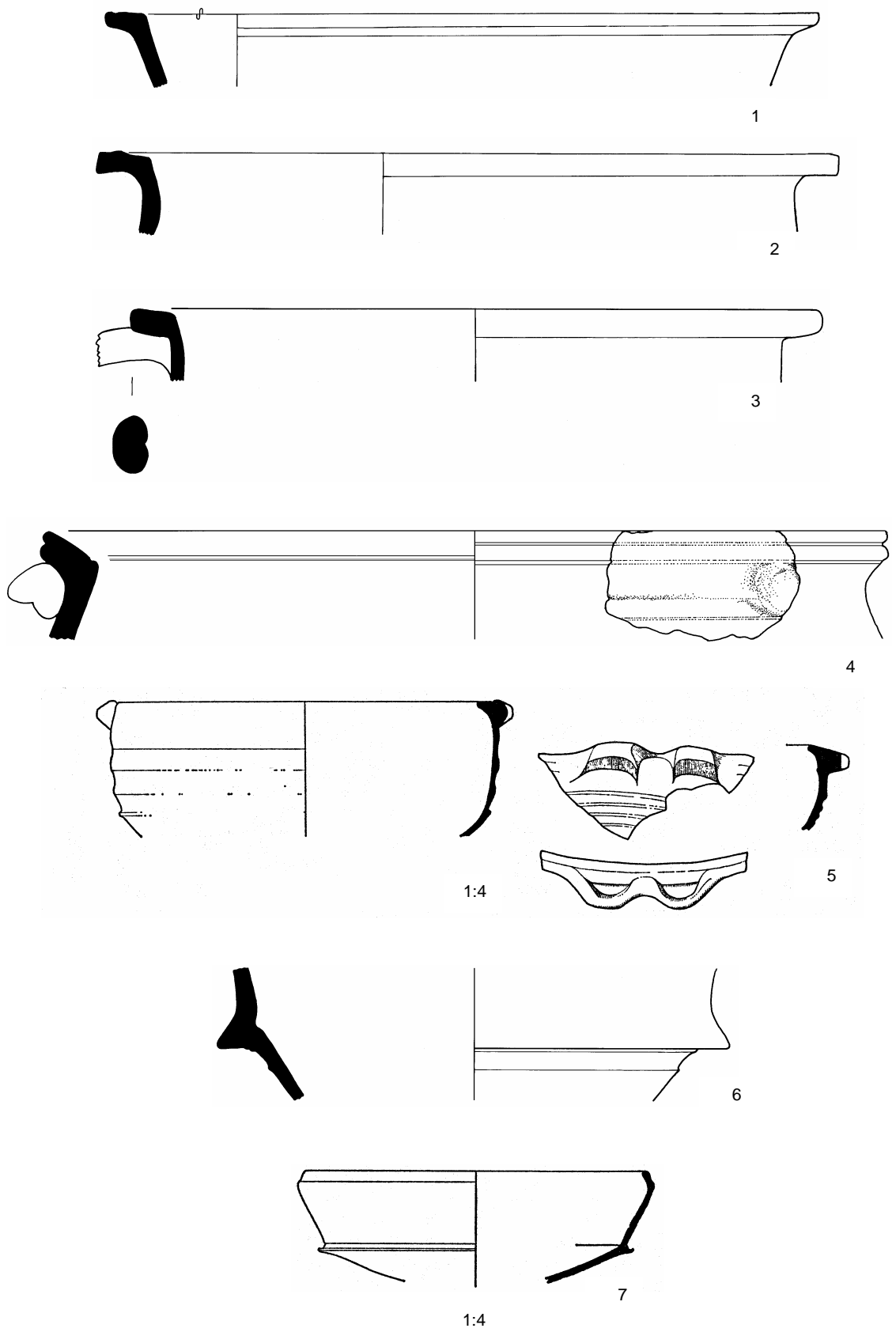

Figure 75 Fourth century Casserole types. Scale 1:2

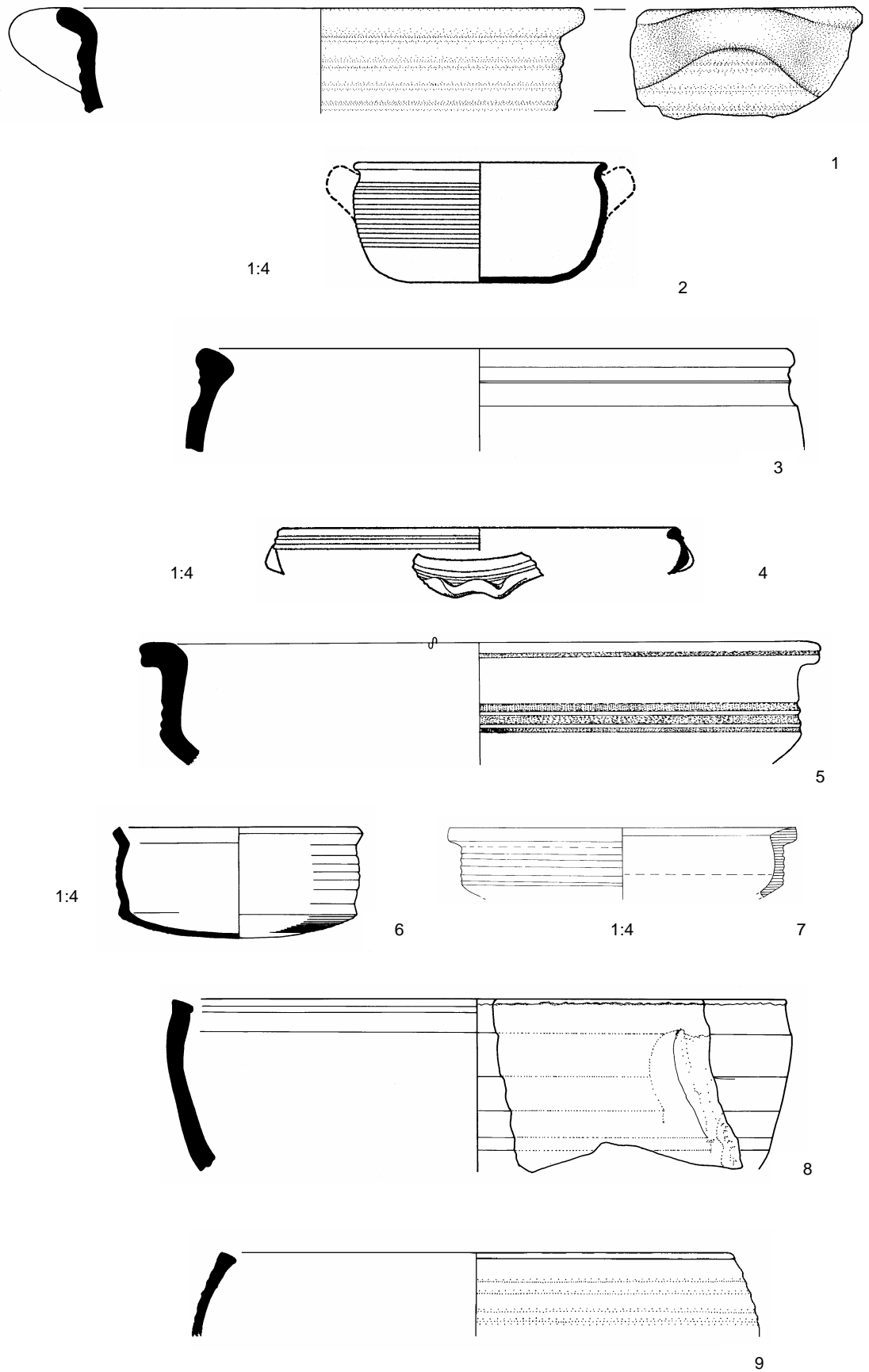

Figure 76 Fifth century Casserole types. Scale 1:2

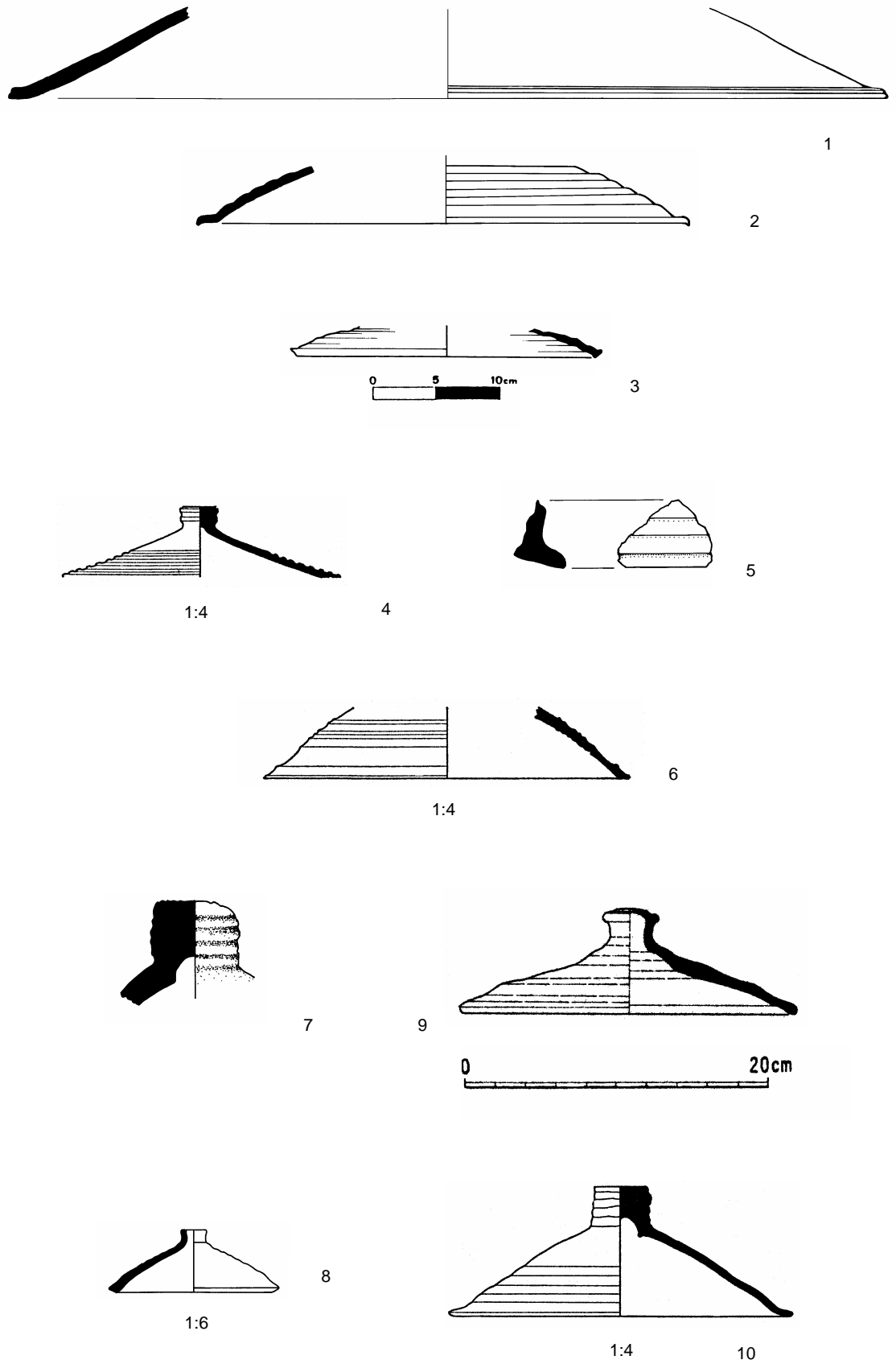

Figure 77 Cooking ware Lids. Scale 1:2

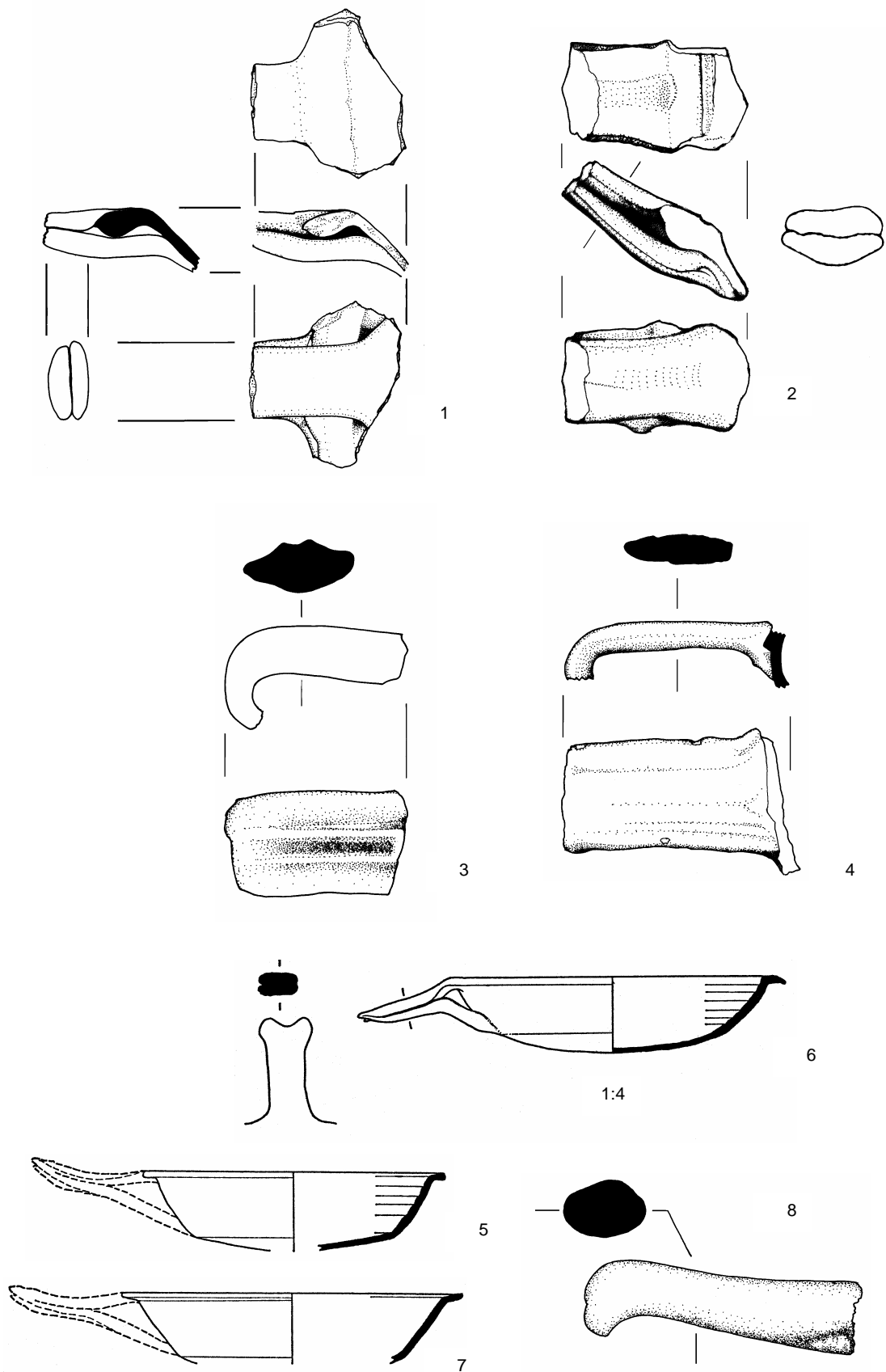

Figure 78 Cooking ware Frying pans. Scale 1:2

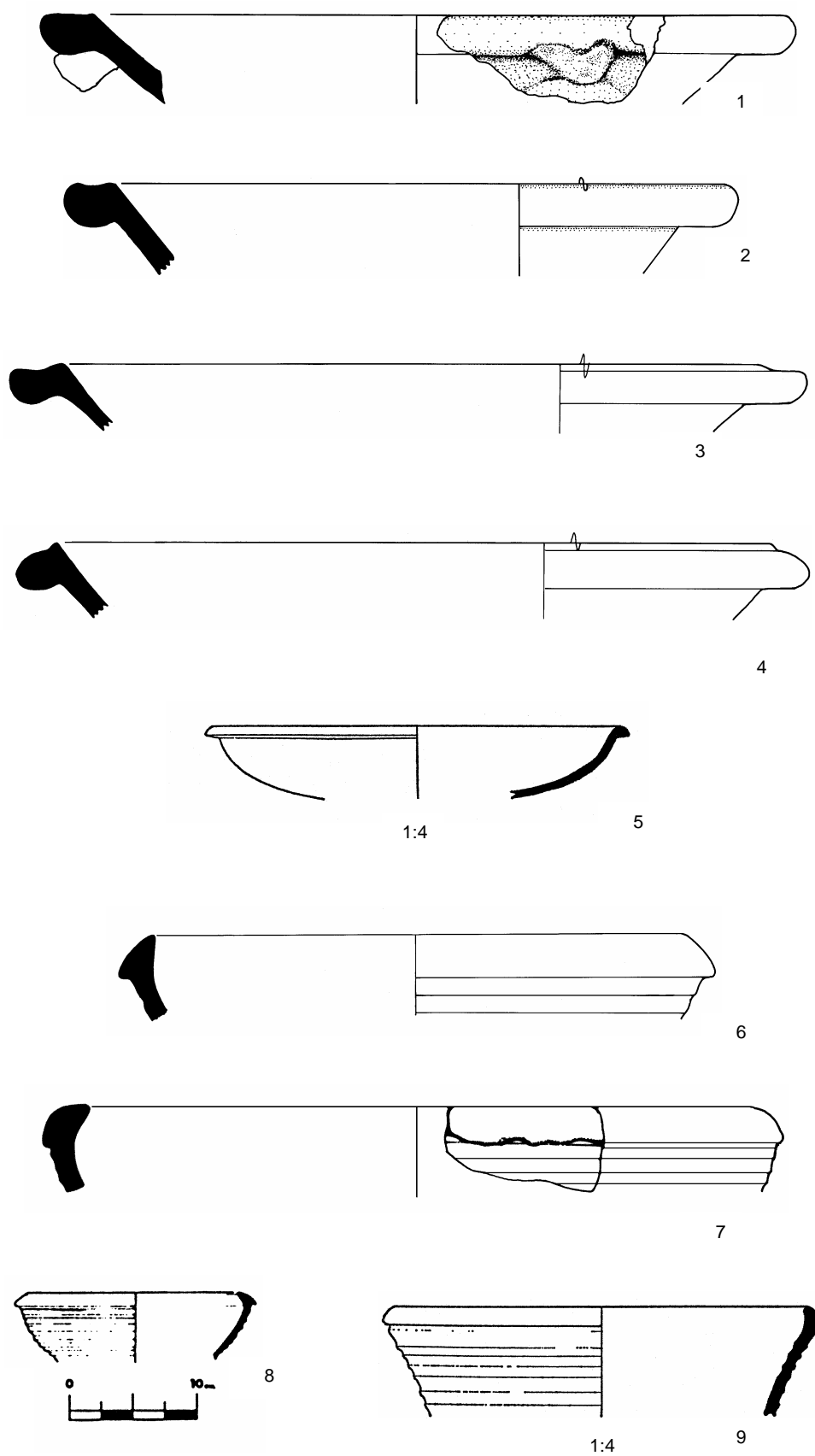

Figure 79 Cooking ware Bowls. Scale 1:2

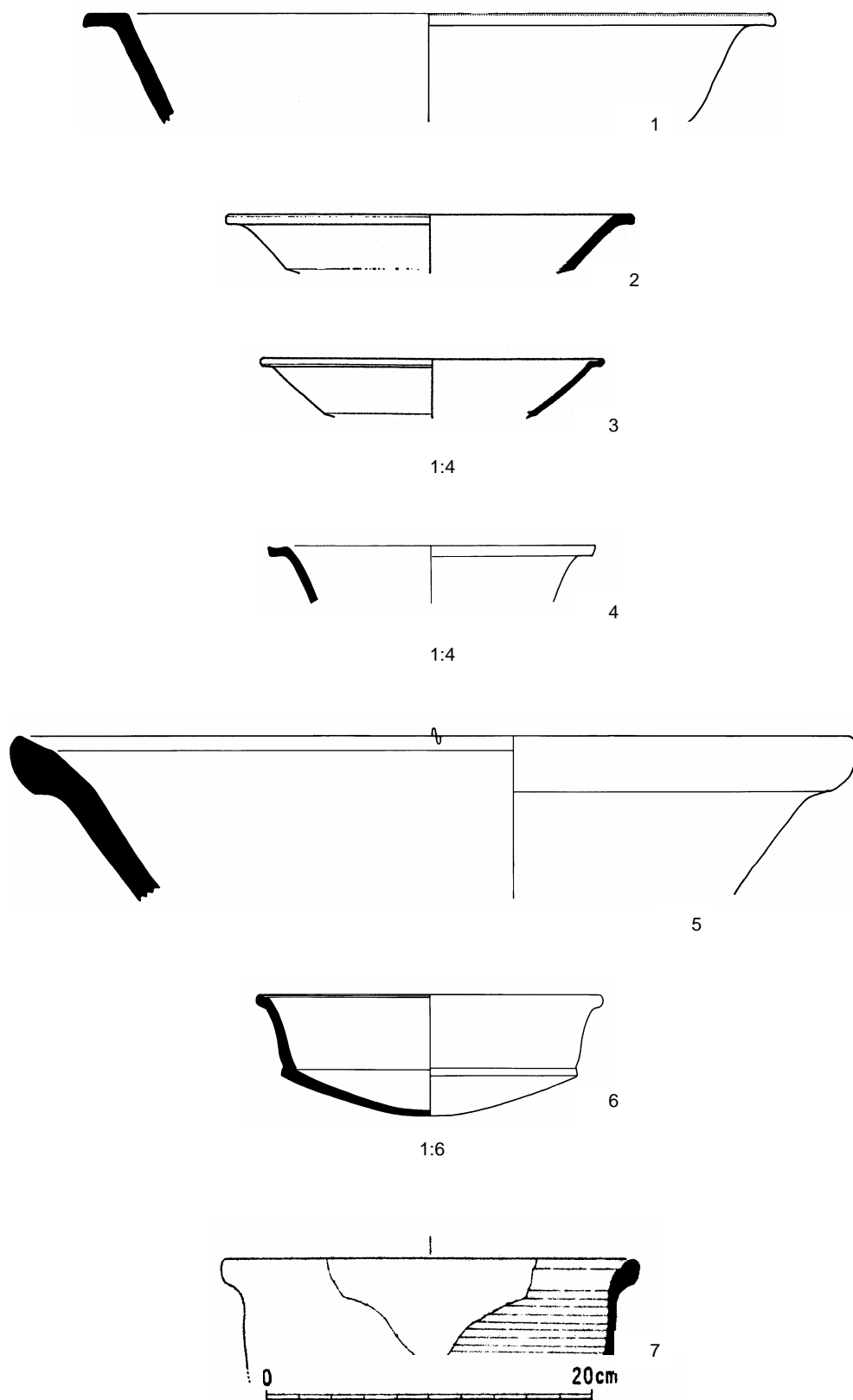

Figure 80 Cooking ware Bowls & Imported bowls. Scale 1:2

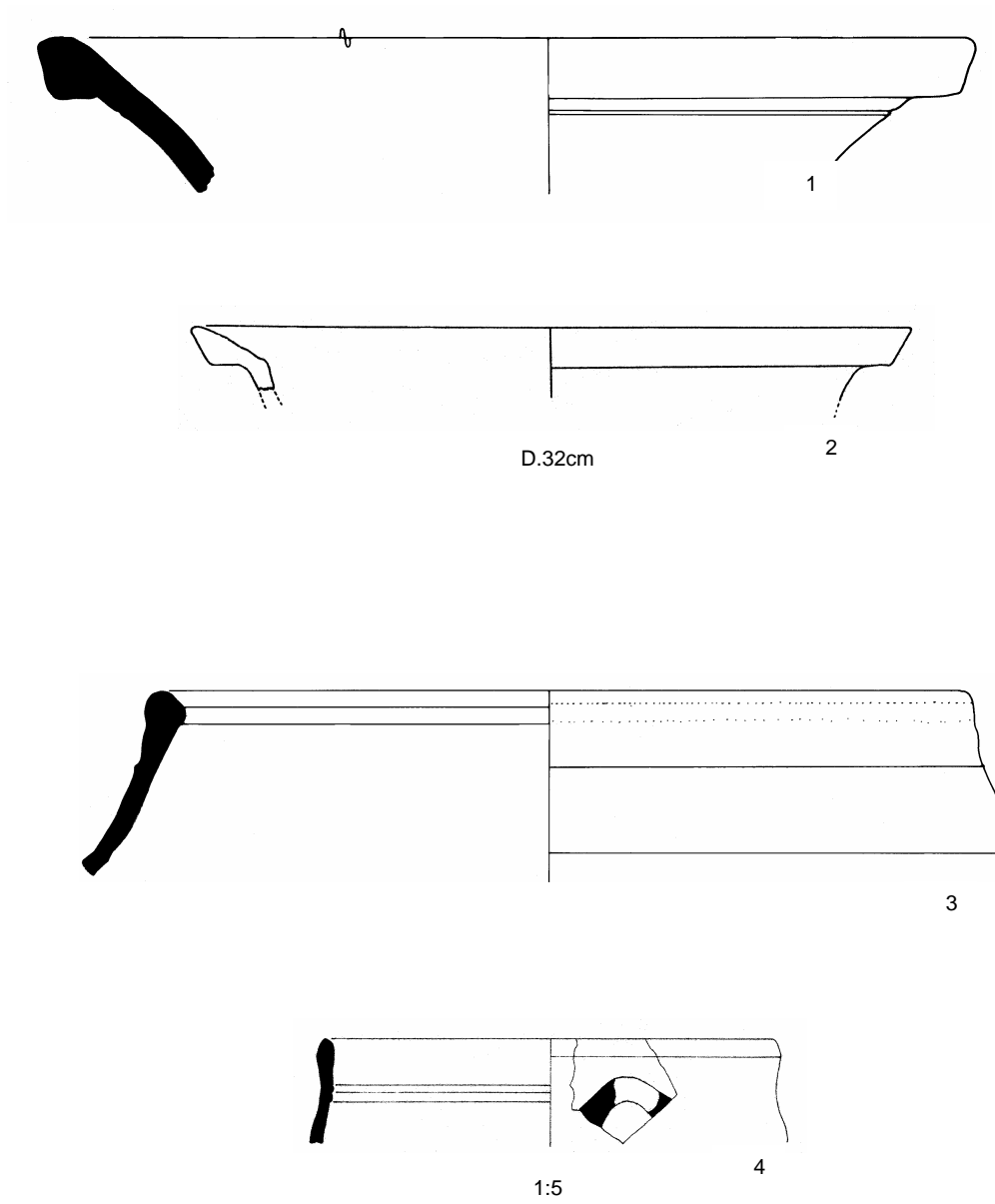

Figure 81 Imported Cooking ware bowls. Scale 1:2

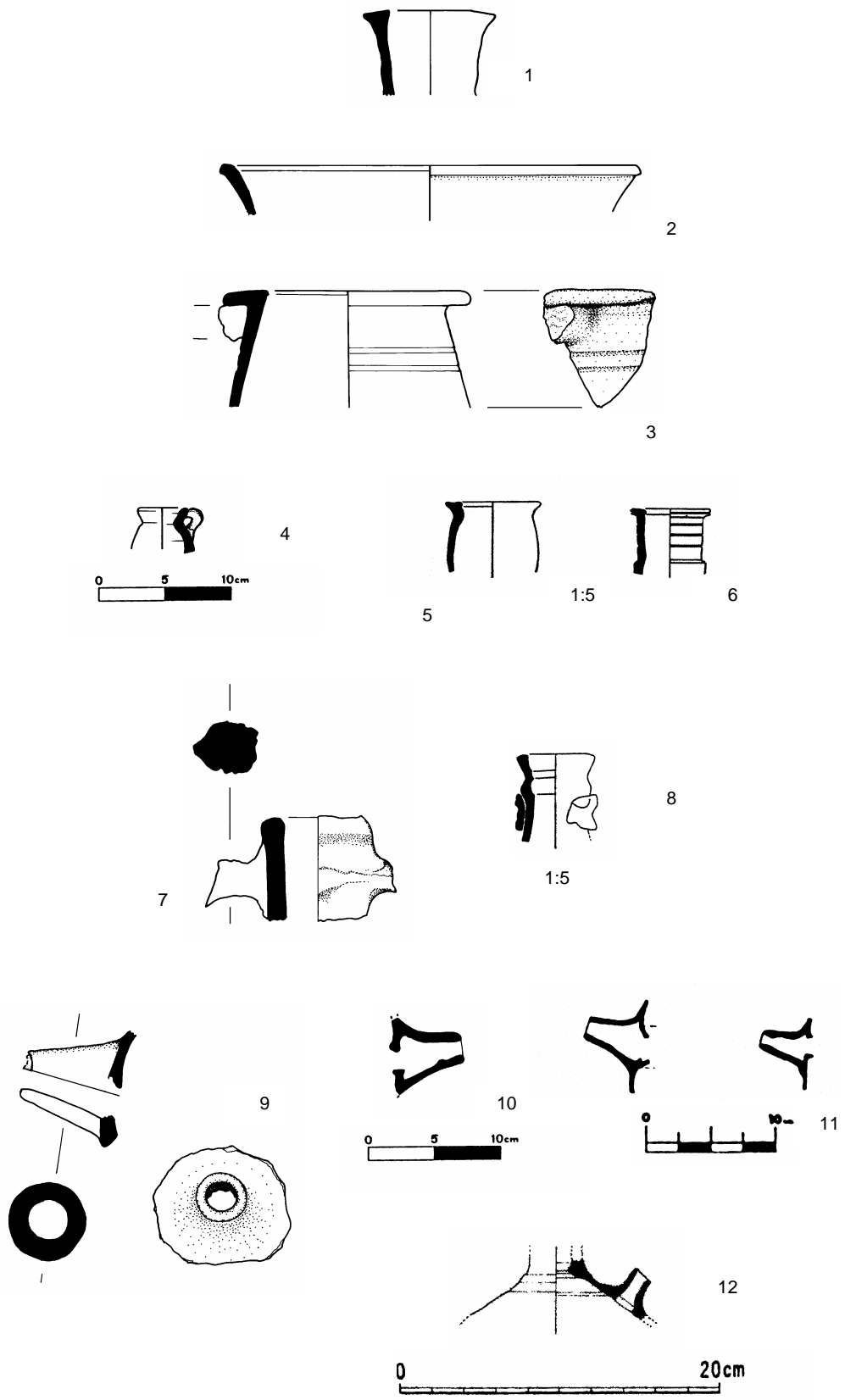

Figure 82 Cooking ware Jugs/Jars. Scale 1:2

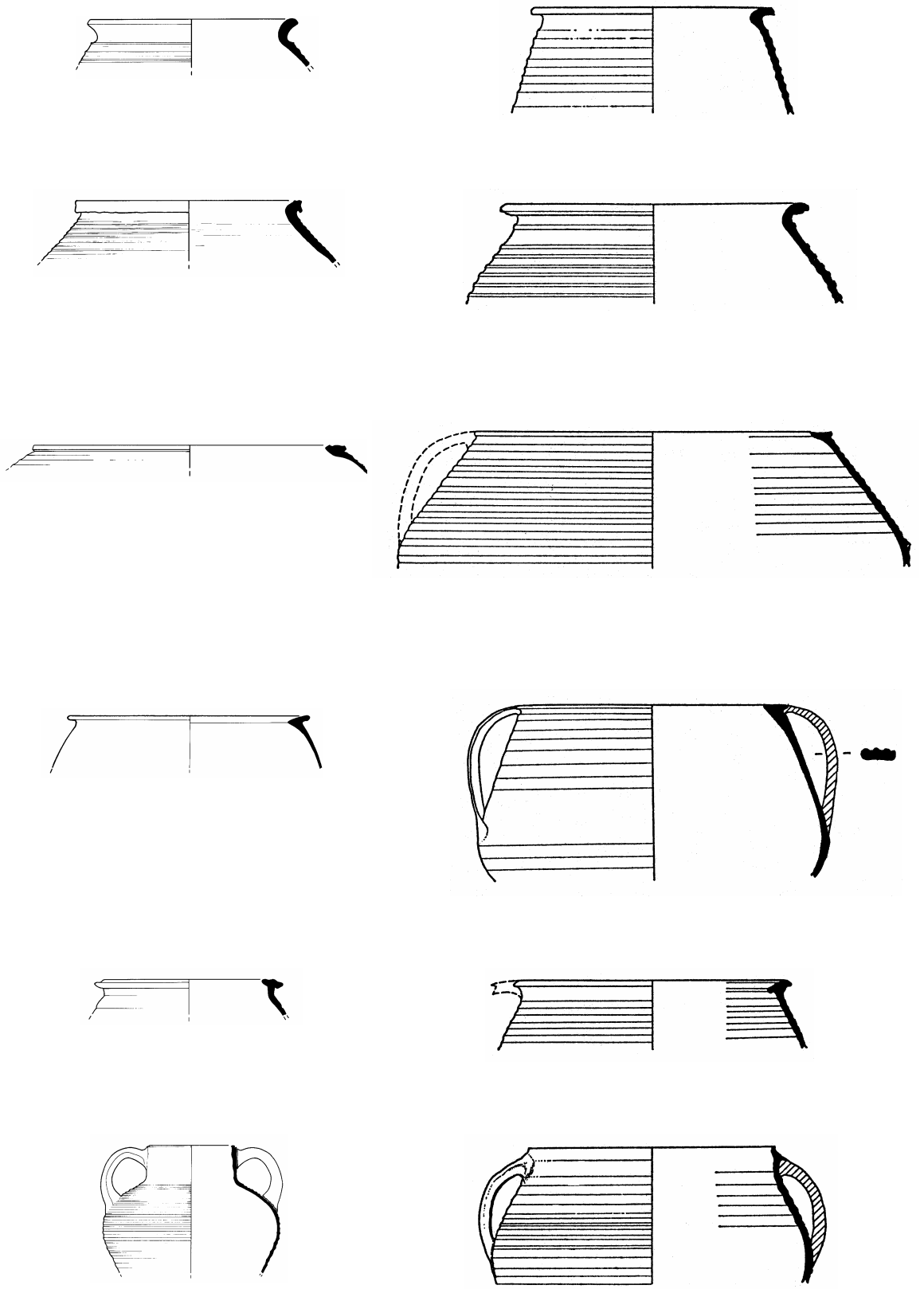

Figure 83 Cooking Pots from Jalame (left) and Dhiorios (right). Scale 1:4

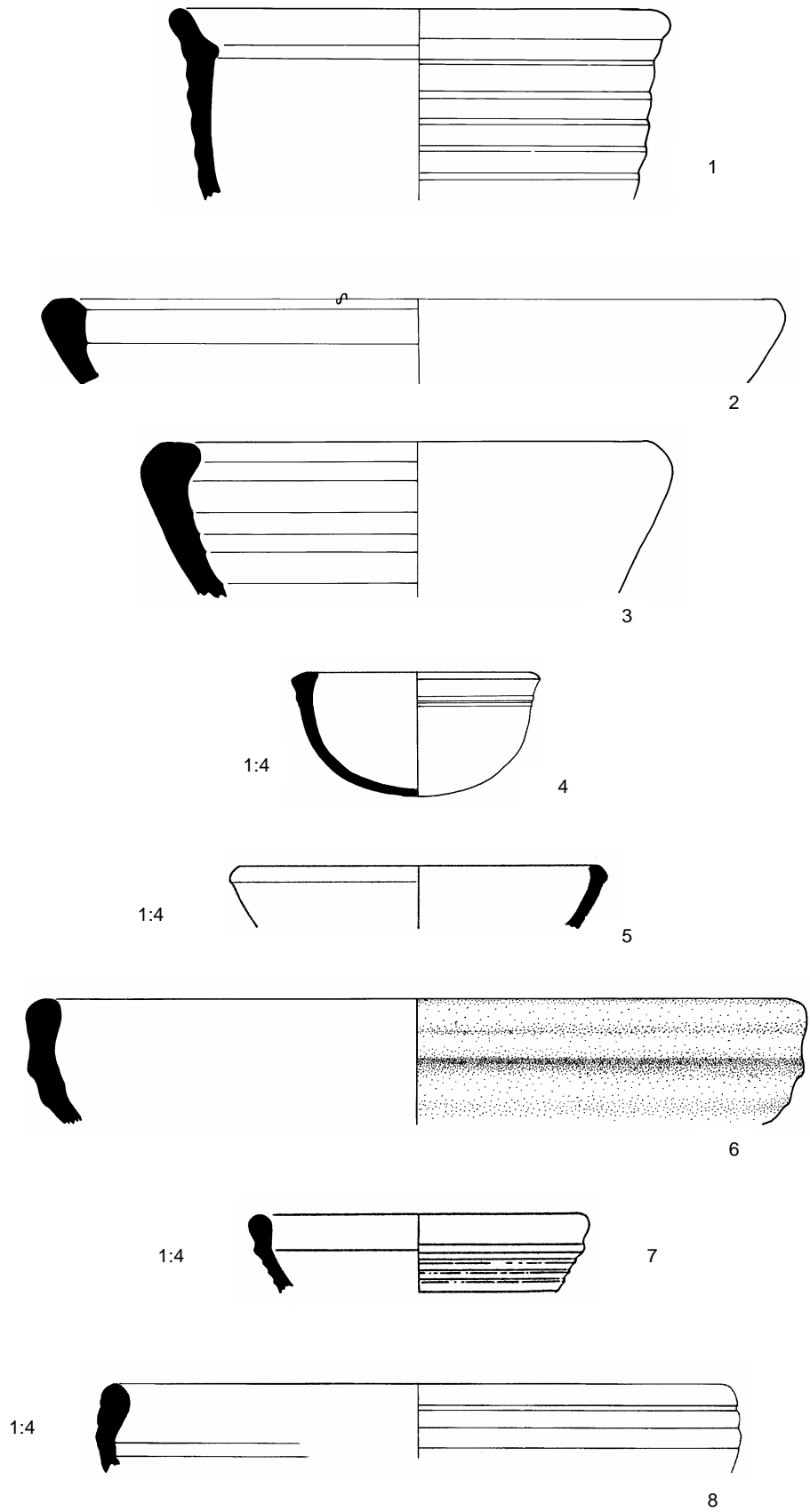

Figure 84 Plain ware Bowls. Scale 1:2

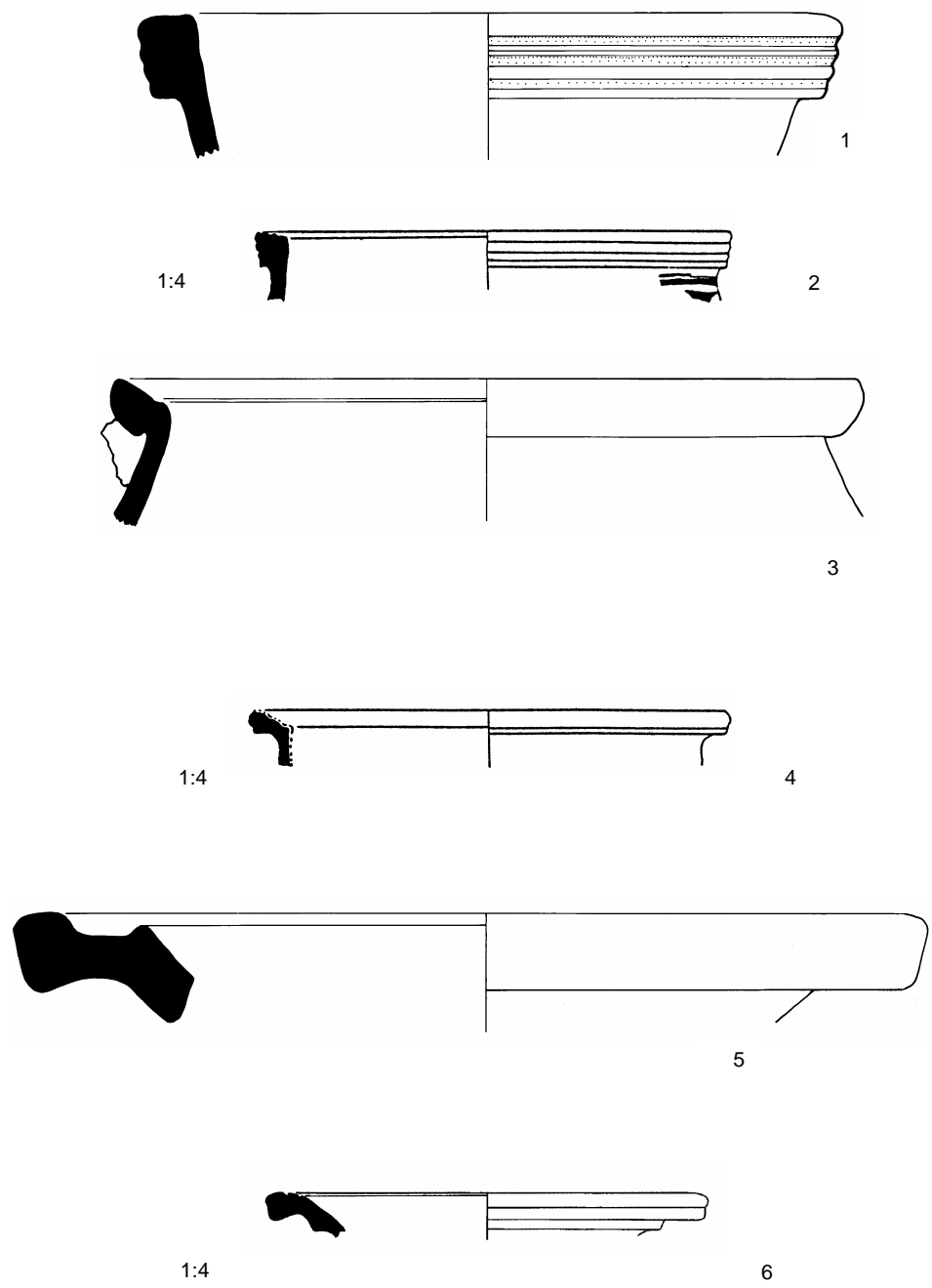

Figure 85 Plain ware Bowls. Scale 1:2

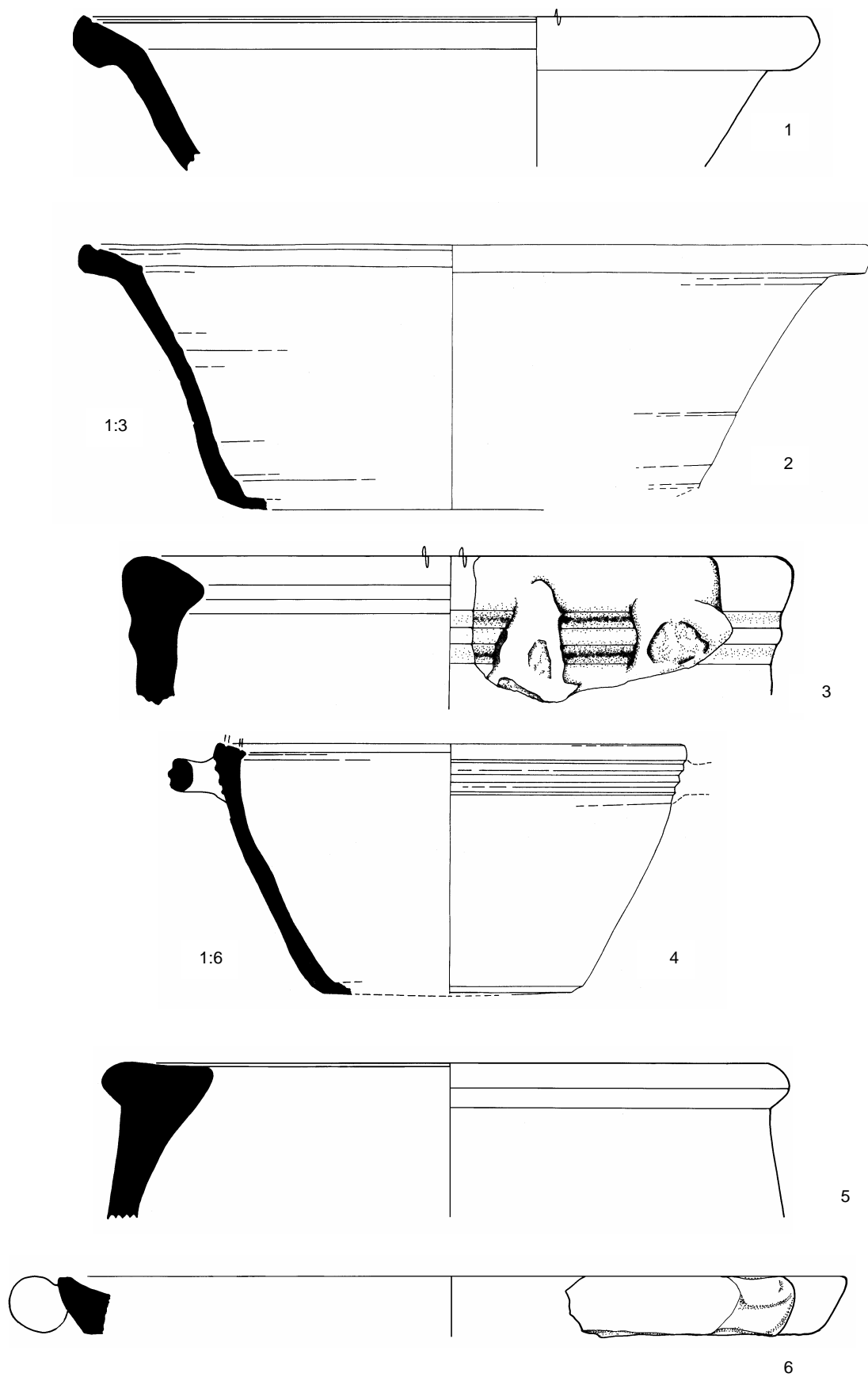

Figure 86 Plain ware Basins. Scale 1:2

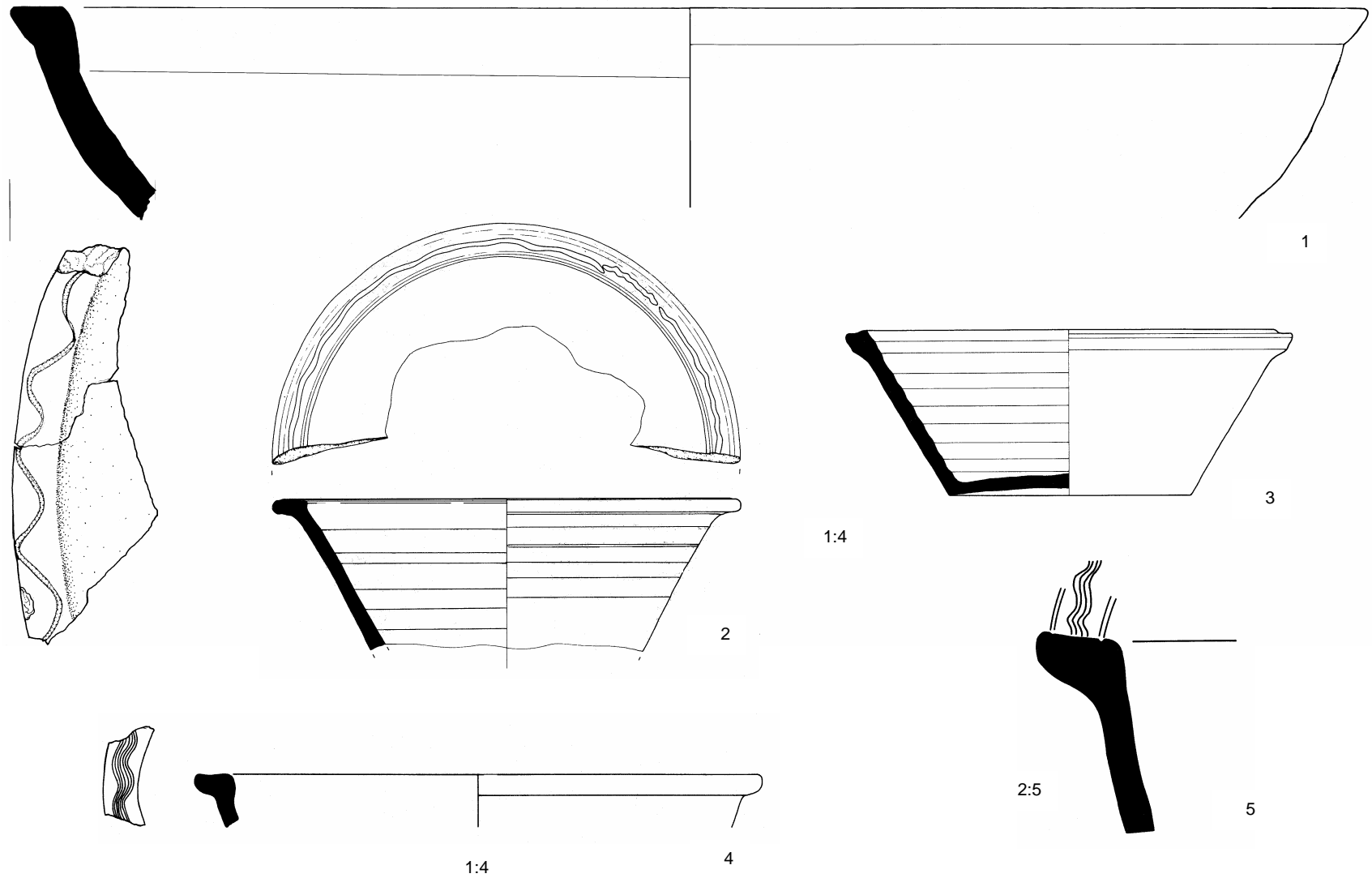

Figure 87 Plain ware Basins. Scale 1:2

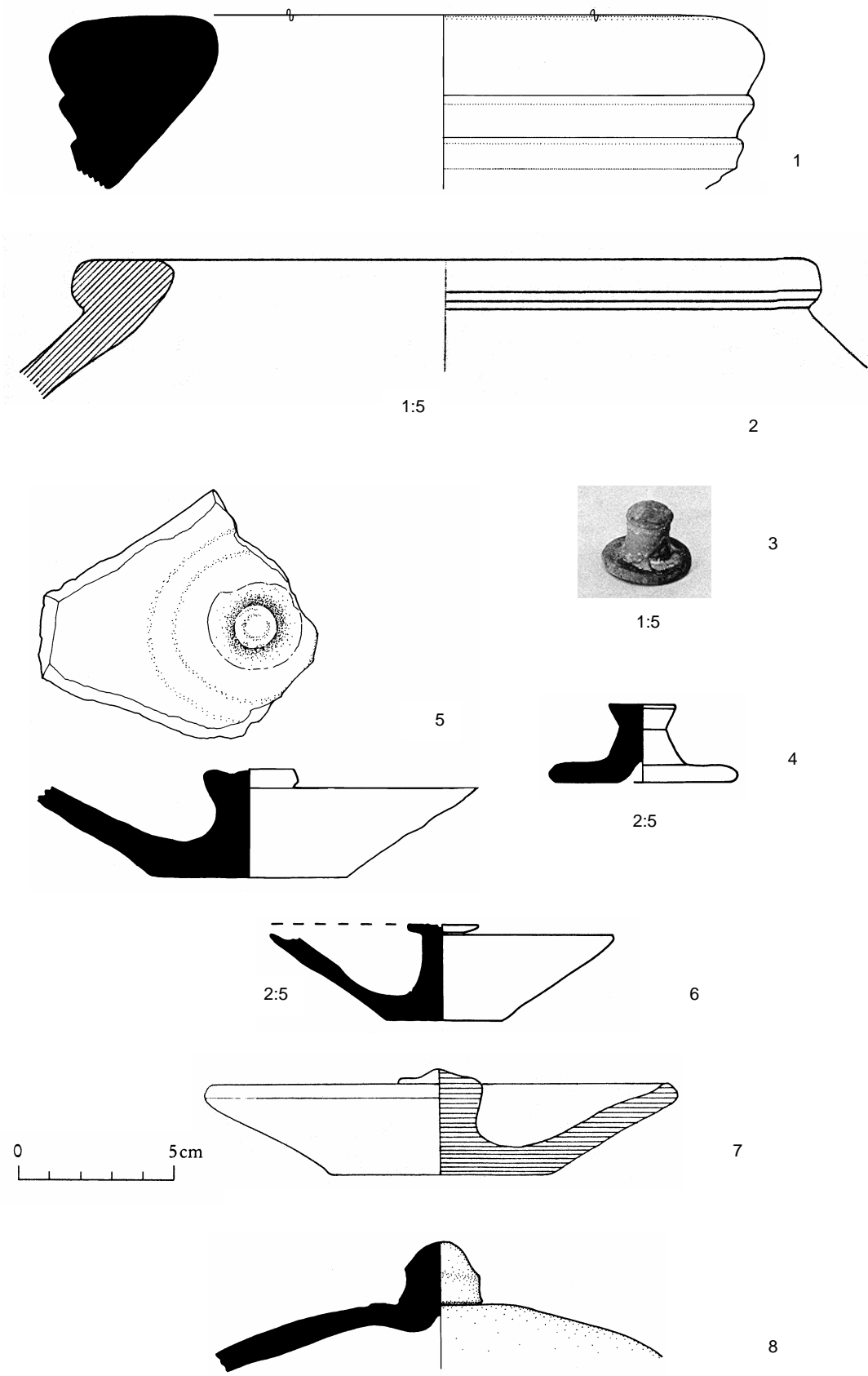

Figure 88 Plain ware Pithoi and Lids. Scale 1:2

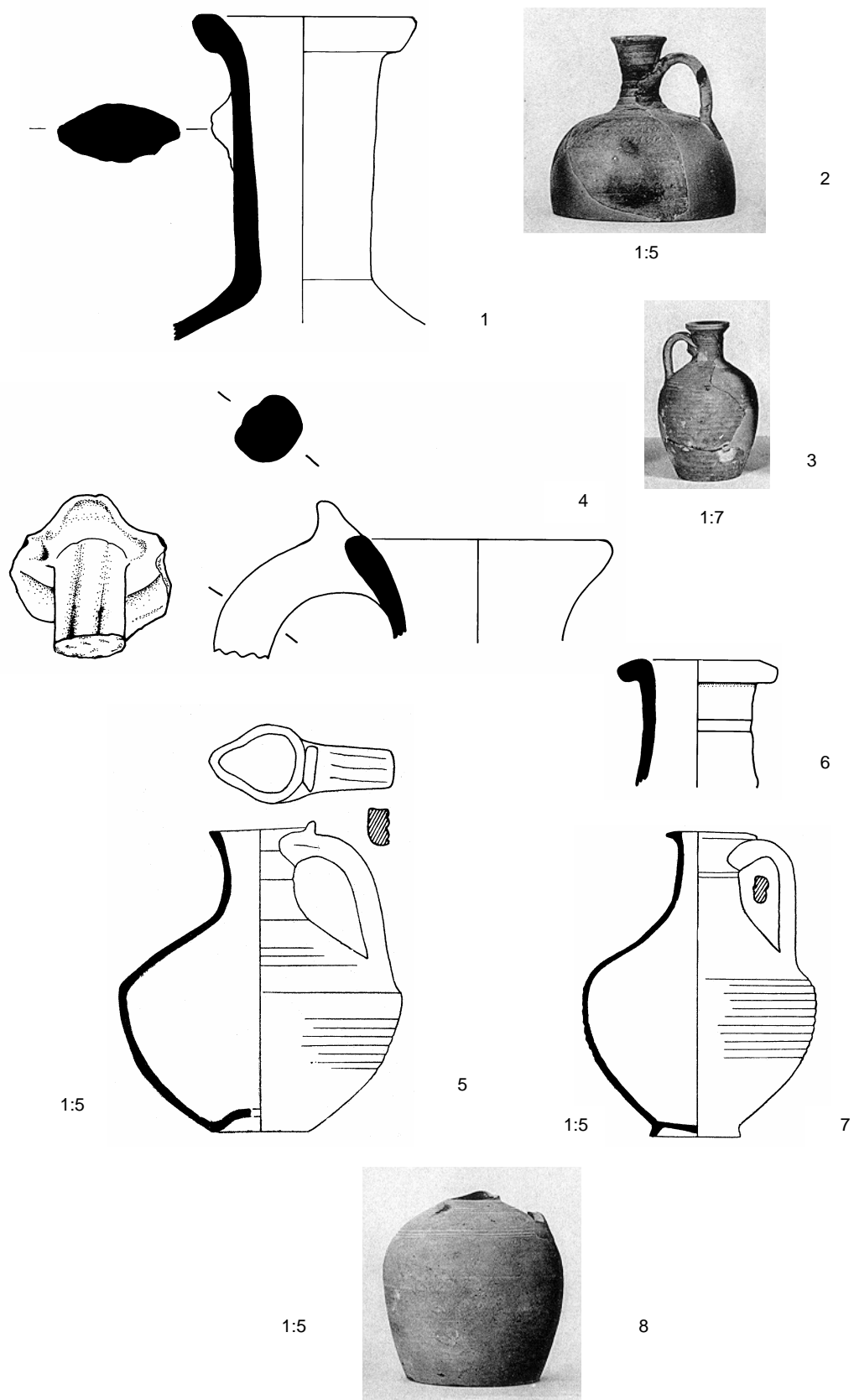

Figure 89 Plain ware Jugs. Scale 1:2

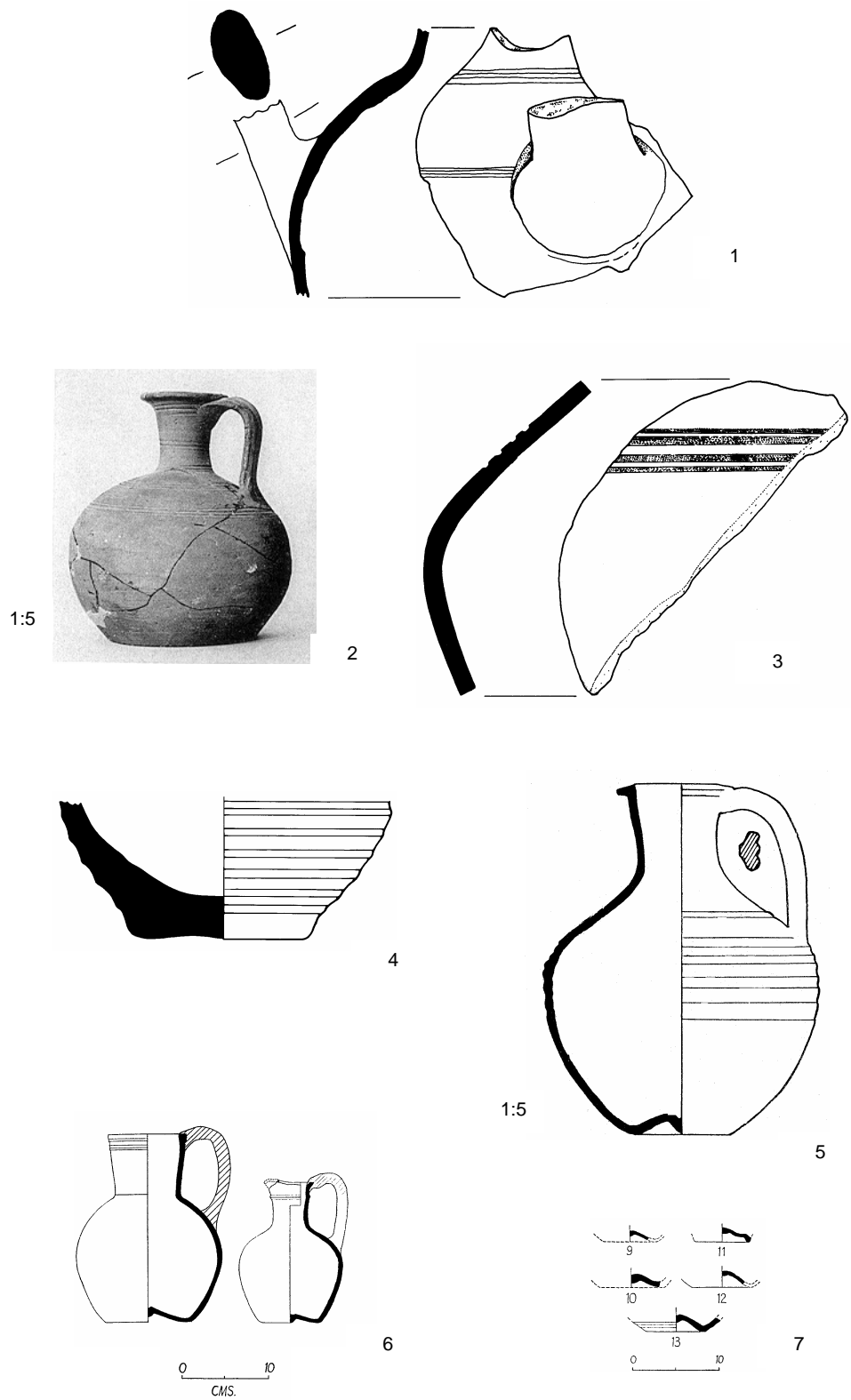

Figure 90 Plain ware Jugs. Scale 1:2

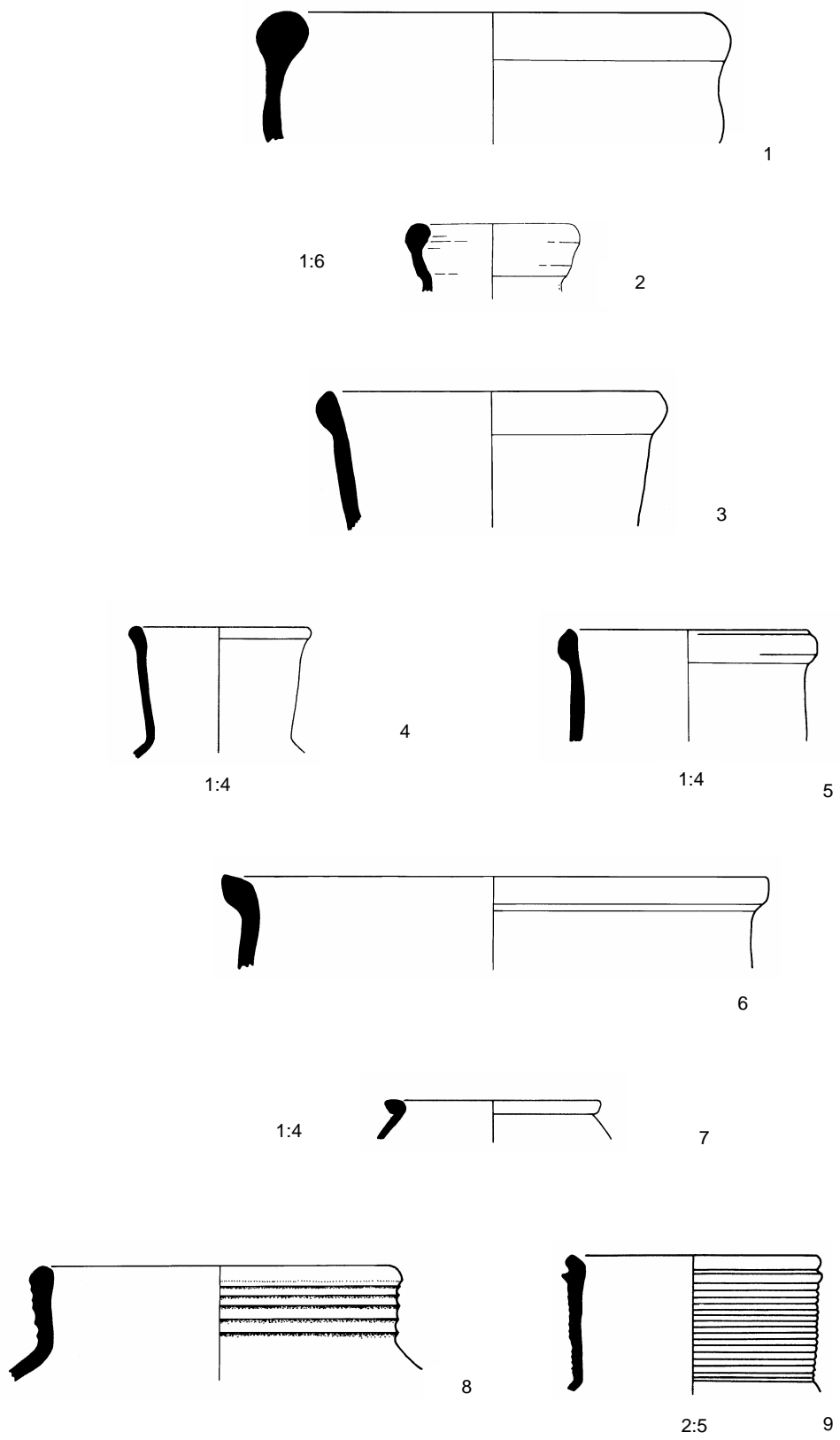

Figure 91 Plain ware Jars. Scale 1:2

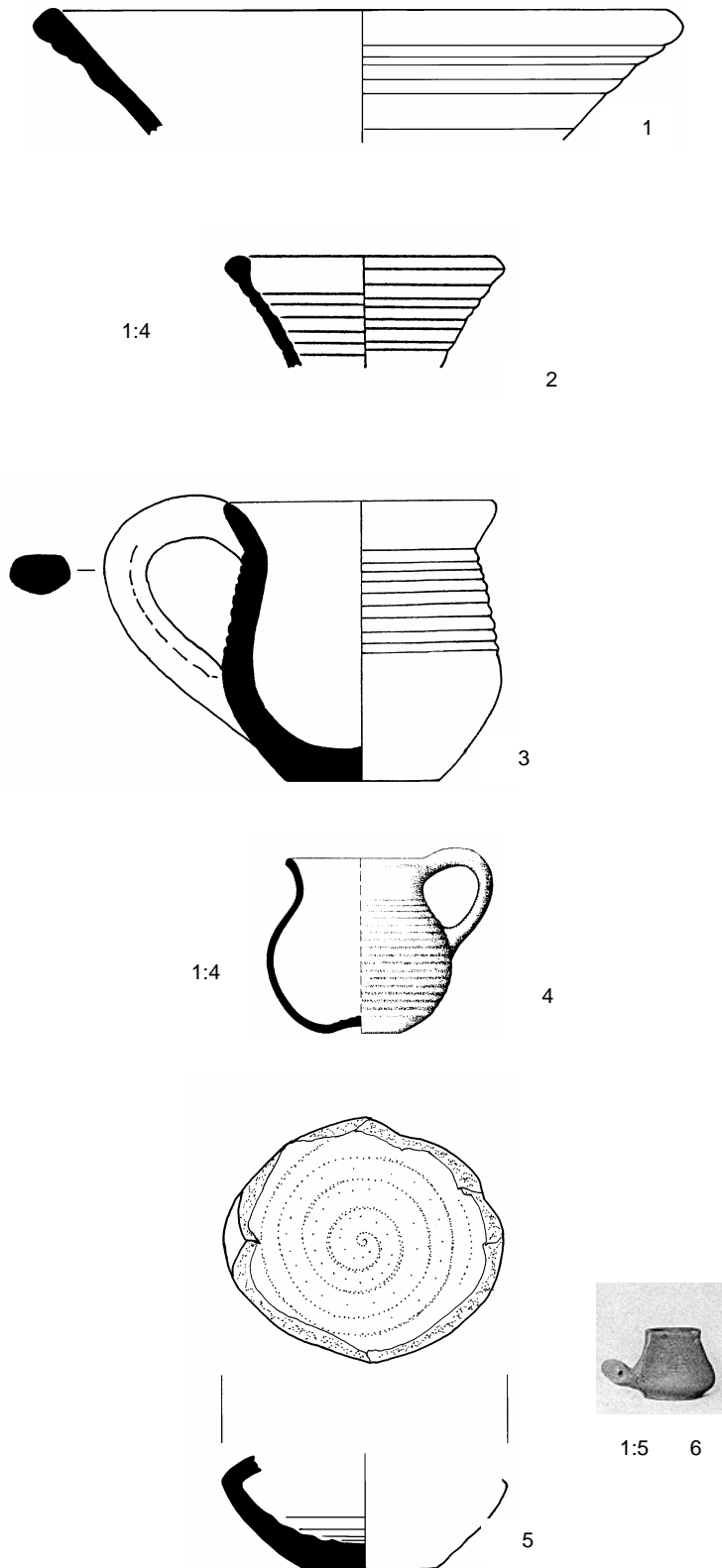

Figure 92 Plain ware Jars and Cups/Beakers. Scale 1:2

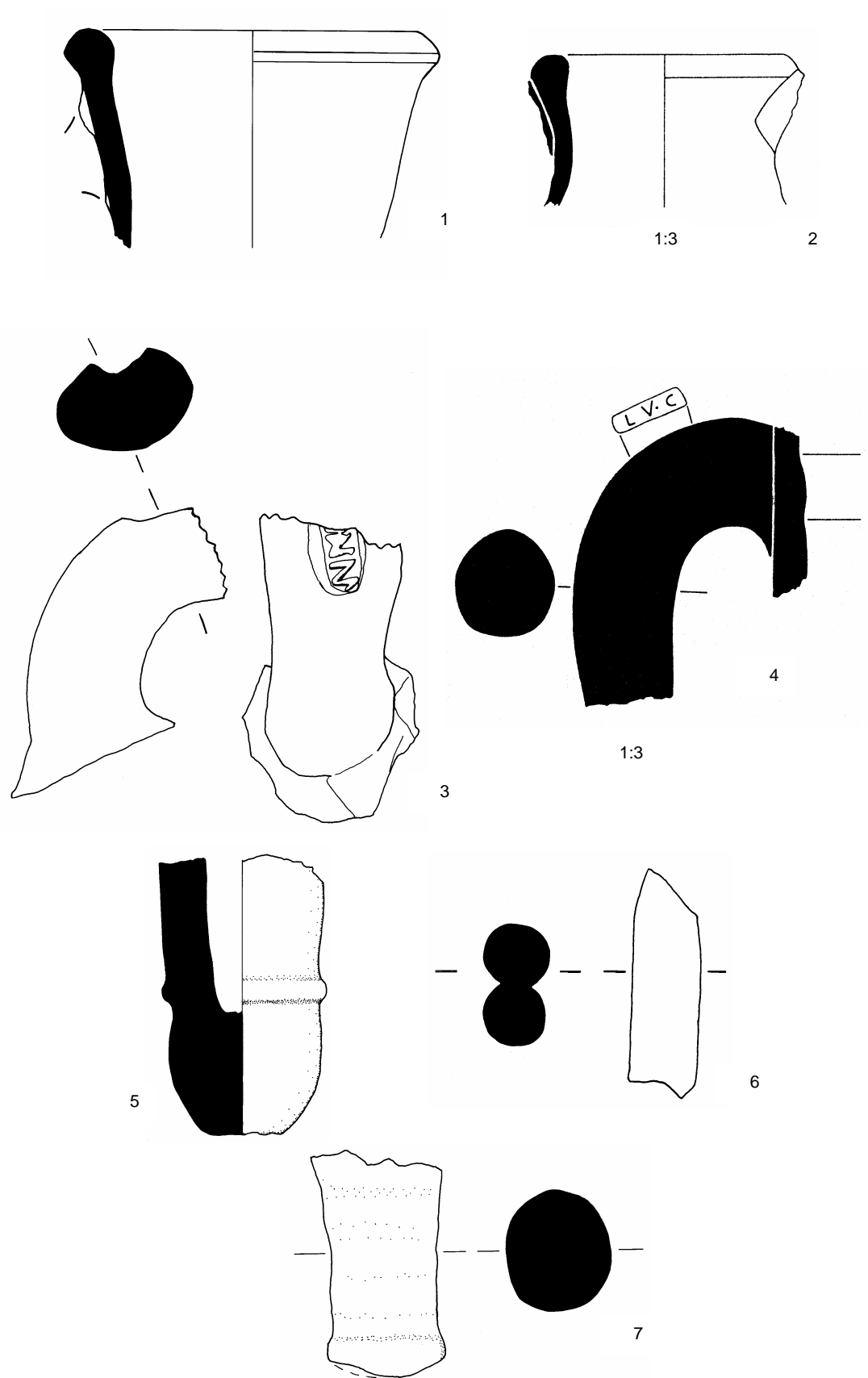
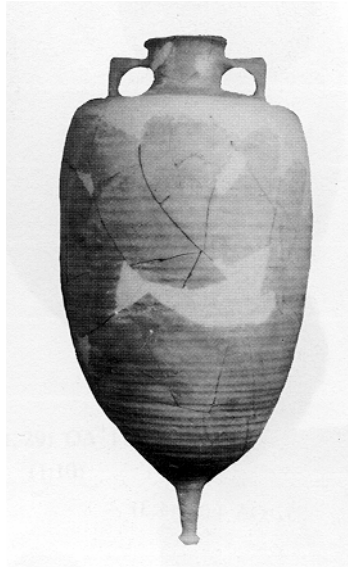
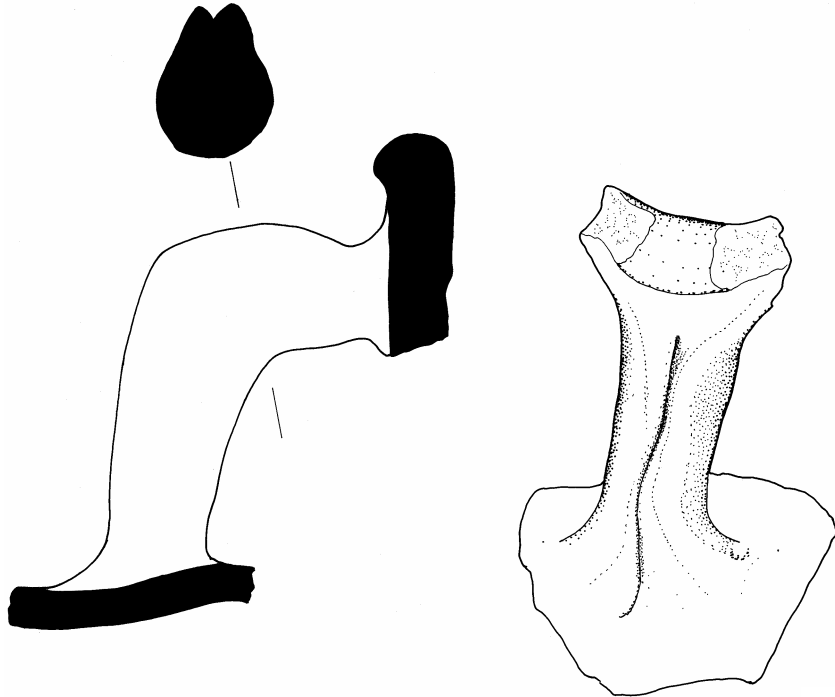

Figure 93 Early Roman Amphorae. Scale 1:2



1:10

1



2

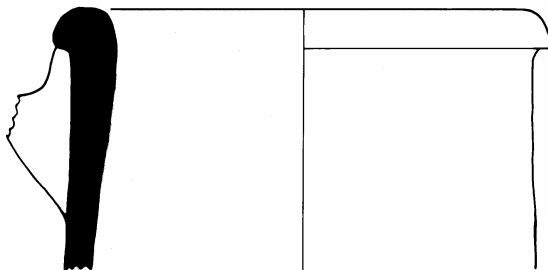

3

Figure 94 Mid Roman 4 Amphorae. Scale 1:2

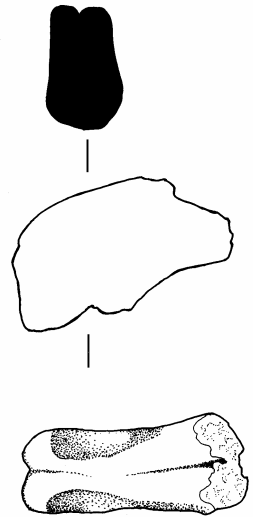
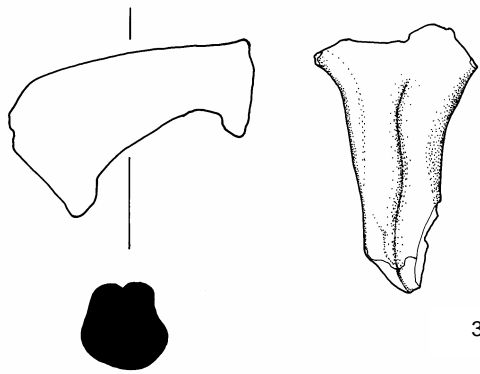
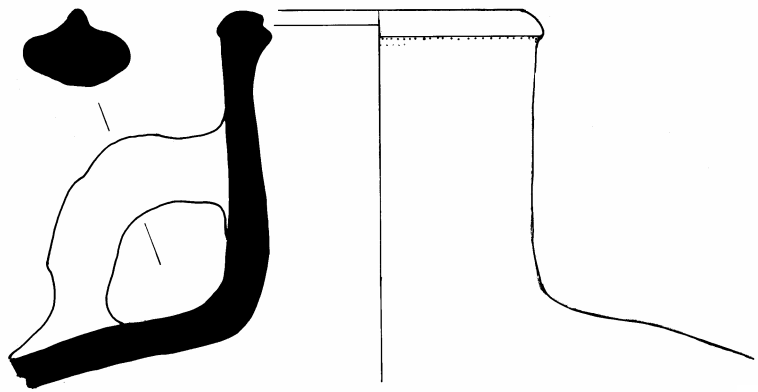
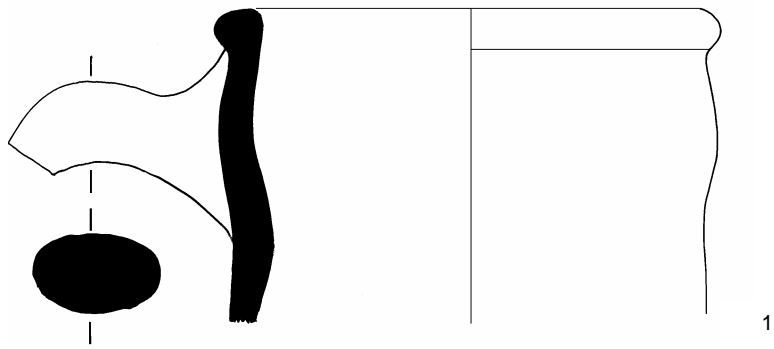

Figure 95 Mid Roman 4 Amphorae. Scale 1:2

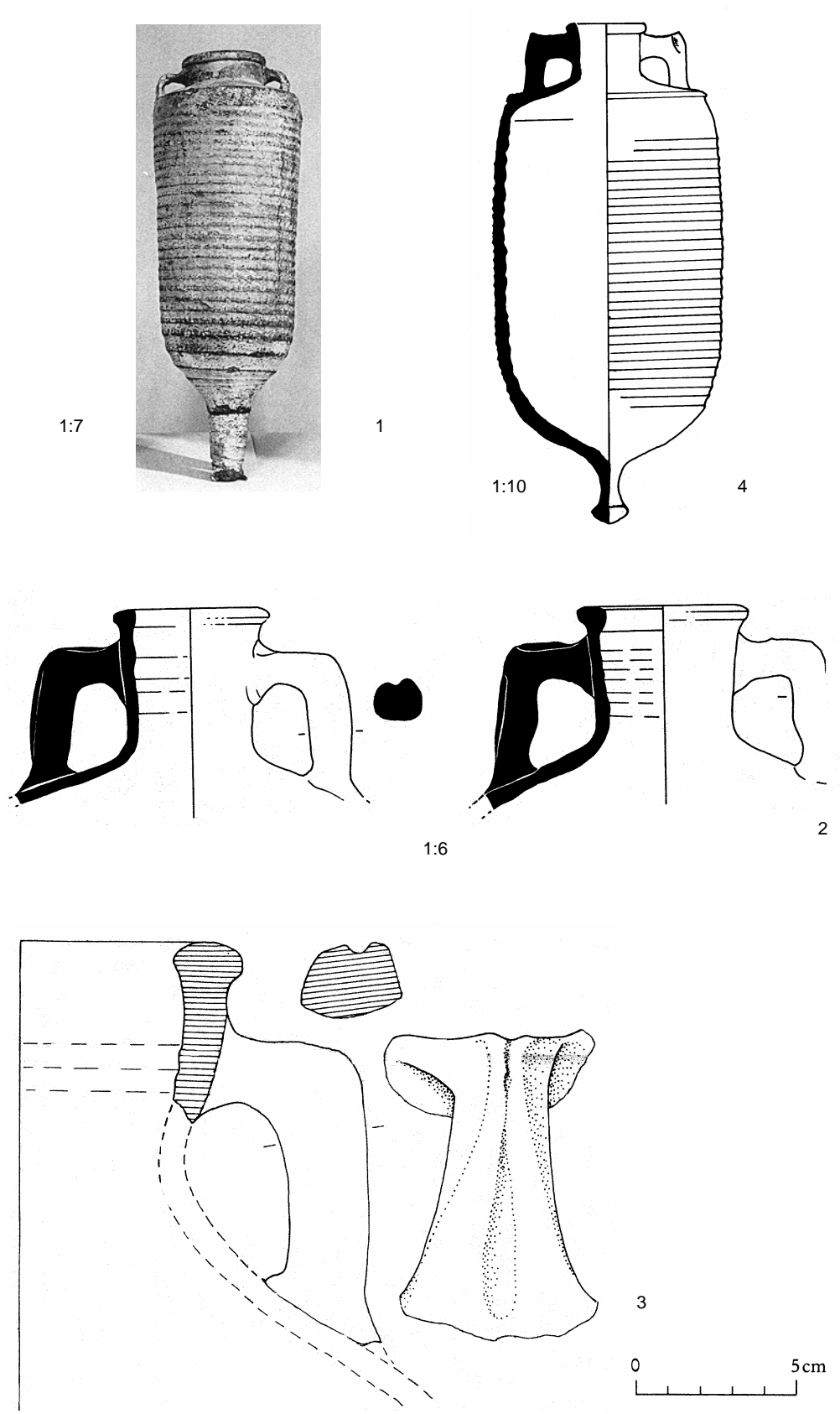
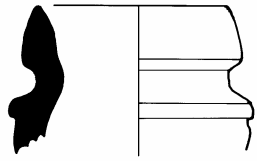
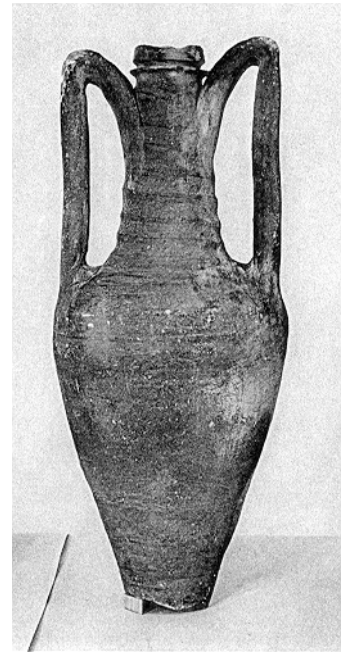

Figure 96 Mid Roman 4 Amphorae. Scale 1:2



1



1:7

2

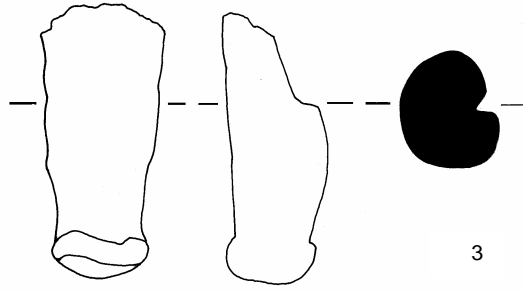

3

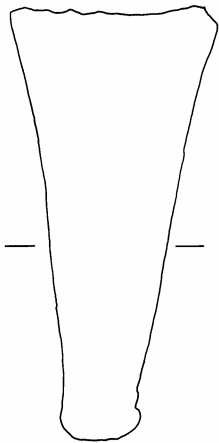

4

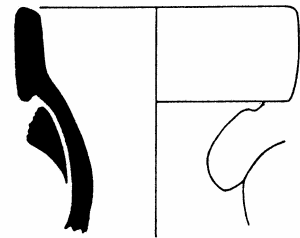
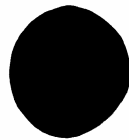

1:3

6

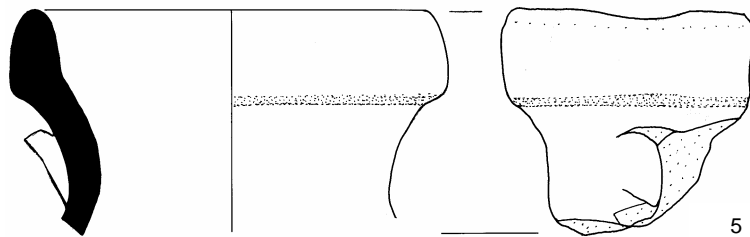

5

Figure 97 Mid Roman Amphorae. Scale 1:2

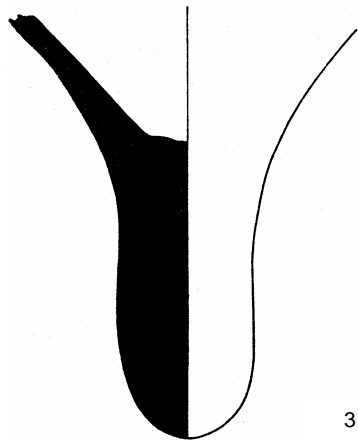
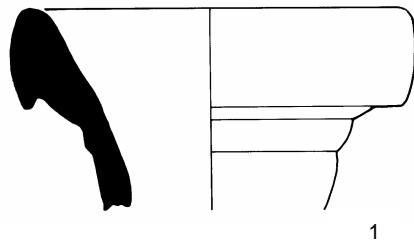

1:3

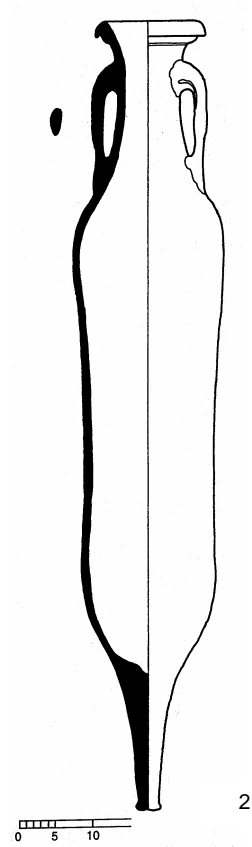

Figure 98 Mid Roman Amphorae. Scale 1:2

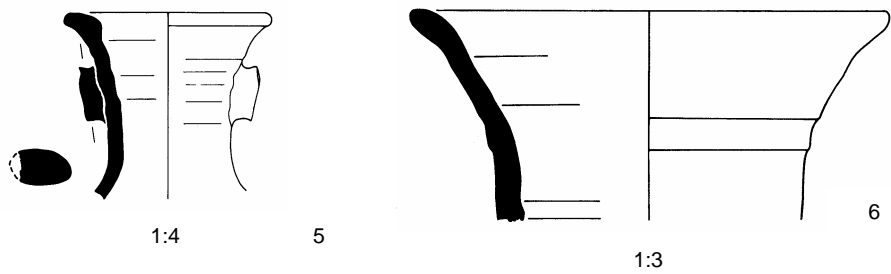
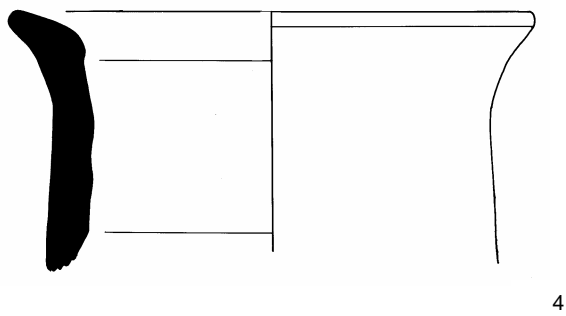
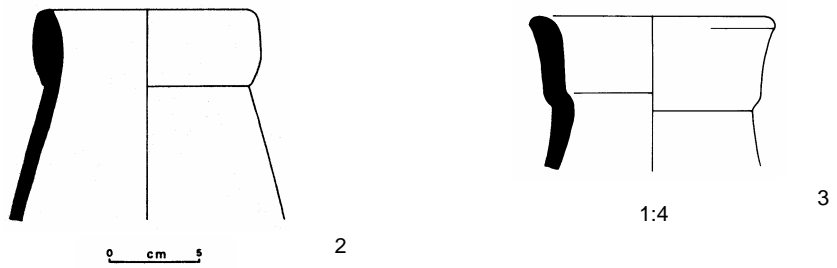
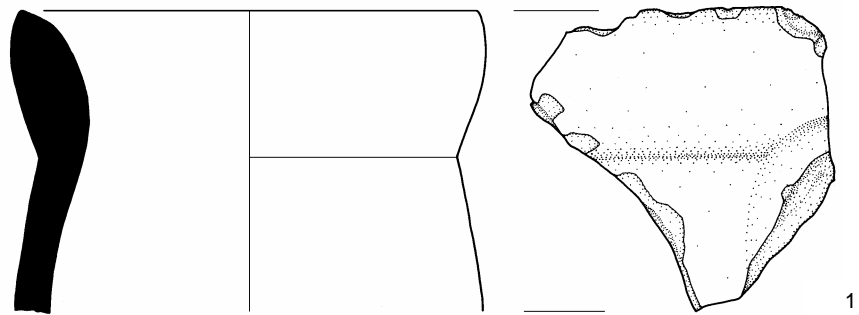

Figure 99 Mid Roman/Late Roman Amphorae. Scale 1:2

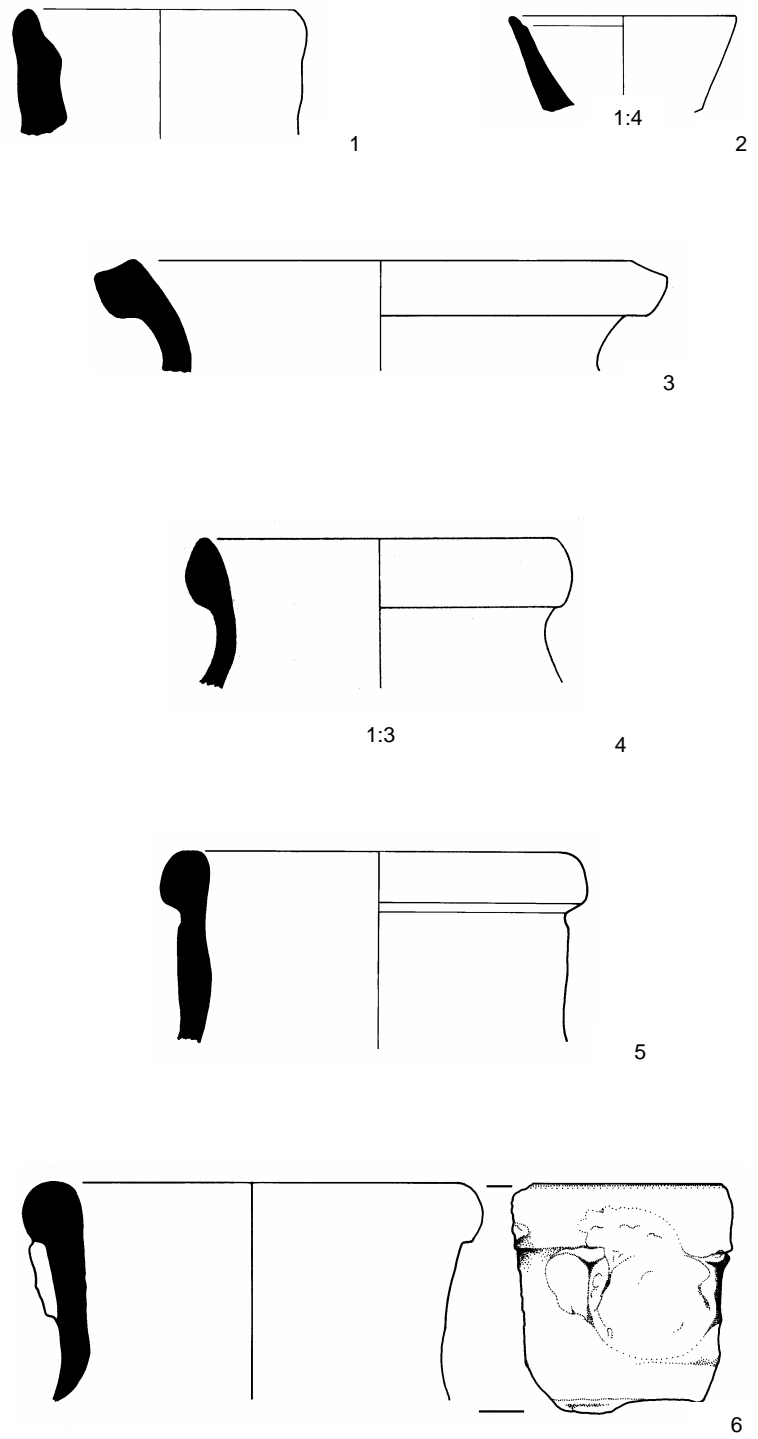

Figure 100 Mid Roman/Late Roman Amphorae. Scale 1:2

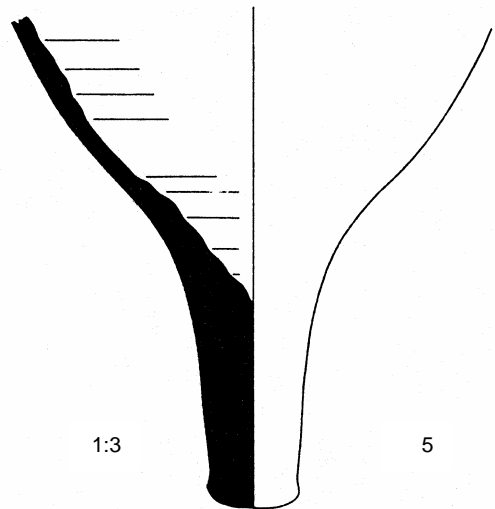
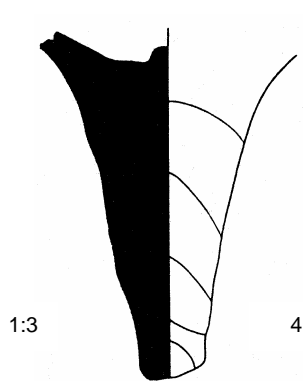
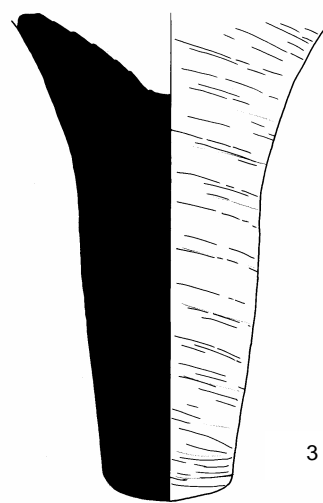
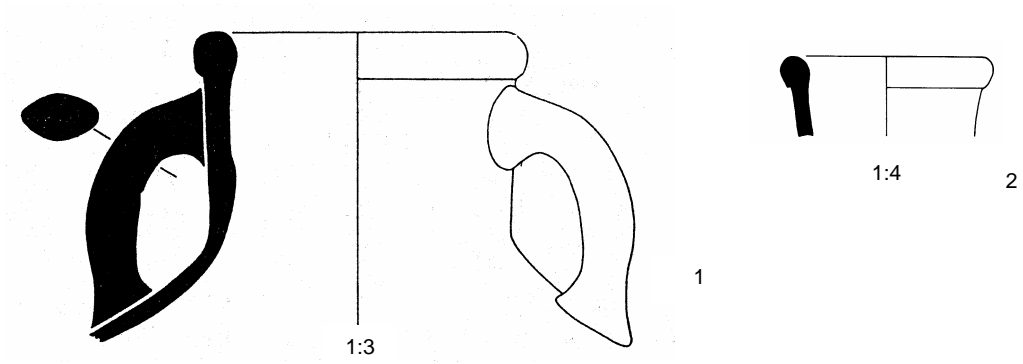

Figure 101 Mid Roman/Late Roman Amphorae. Scale 1:2

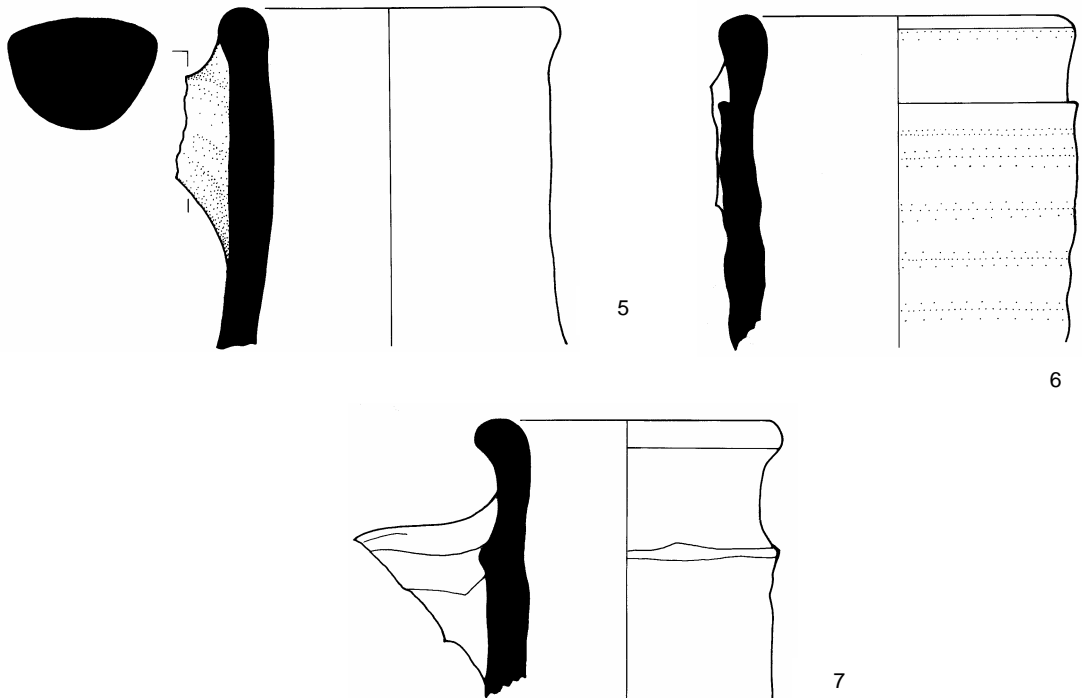
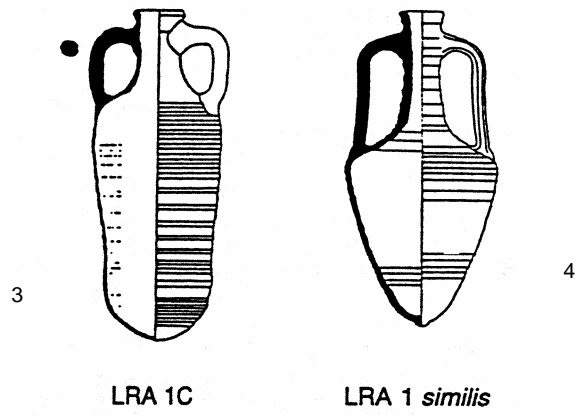
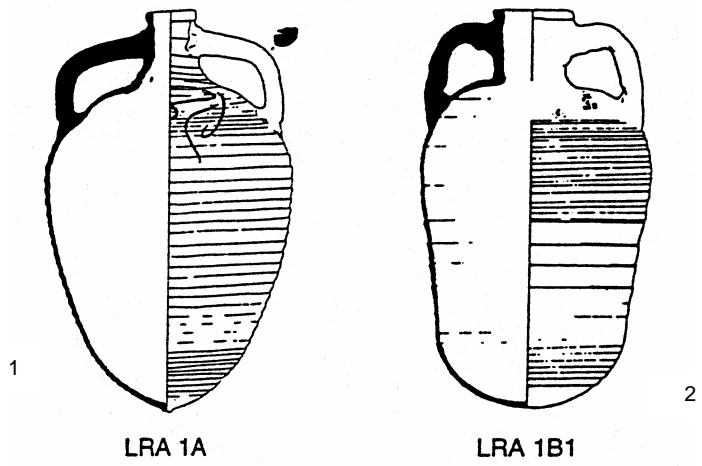

Figure 102 Late Roman 1 Amphorae. Scale 1:2

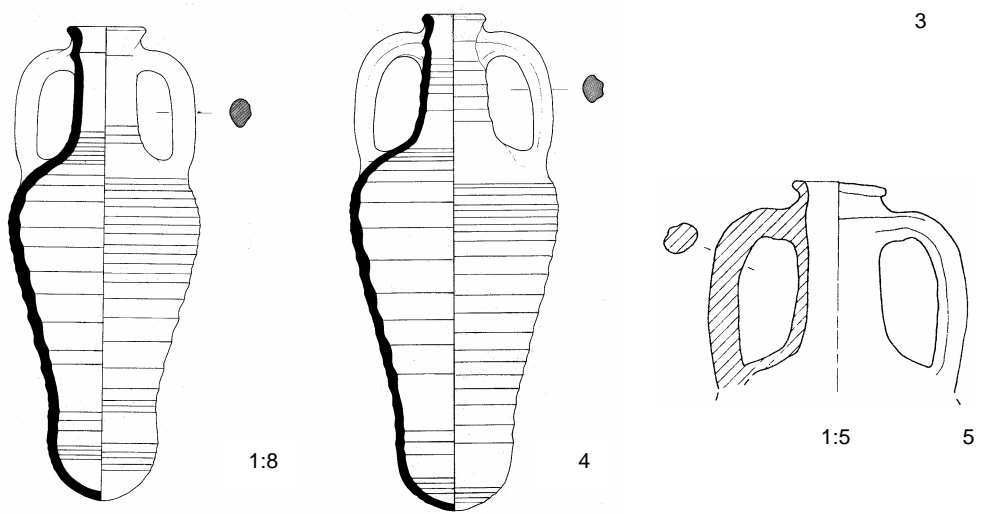
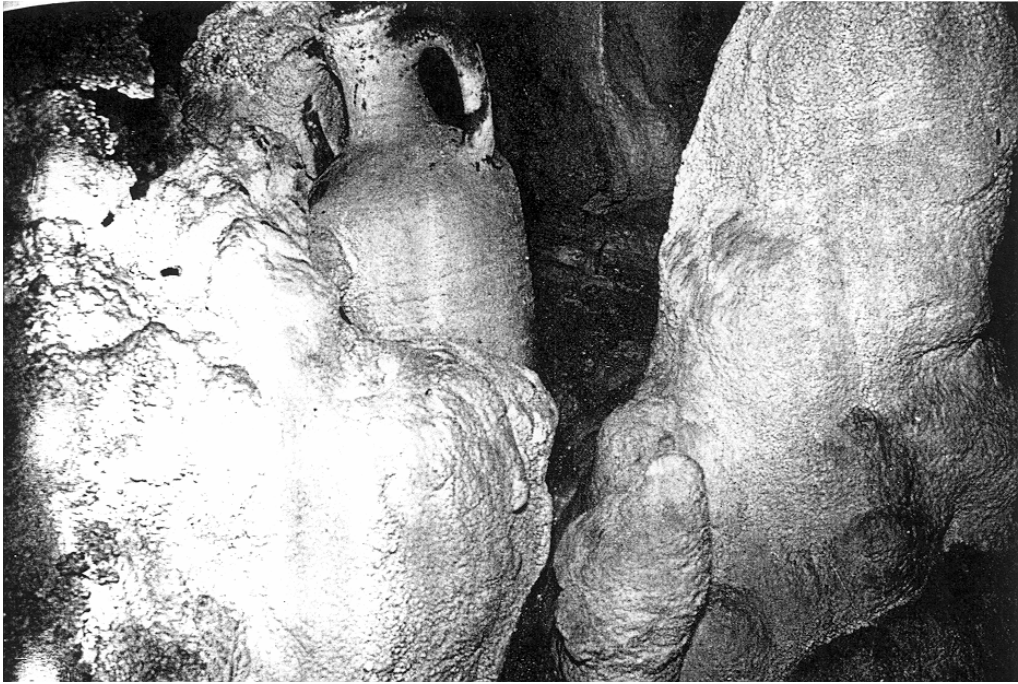
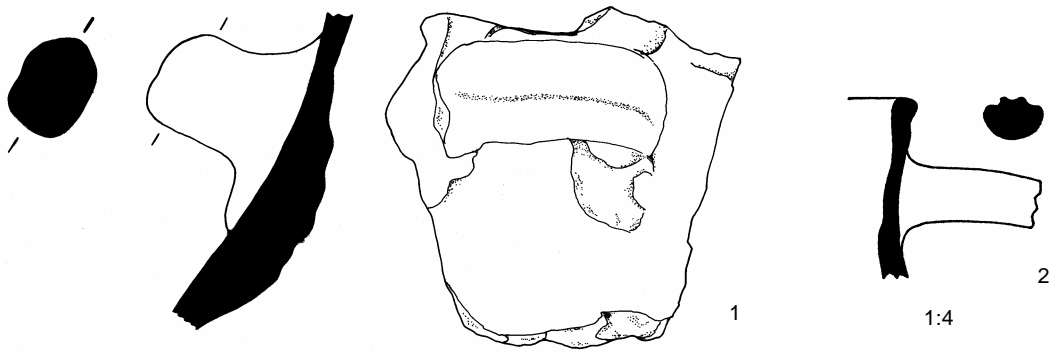

Figure 103 Late Roman 1 Amphorae. Scale 1:2

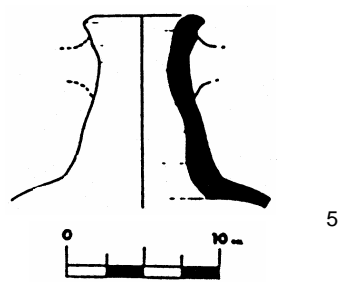
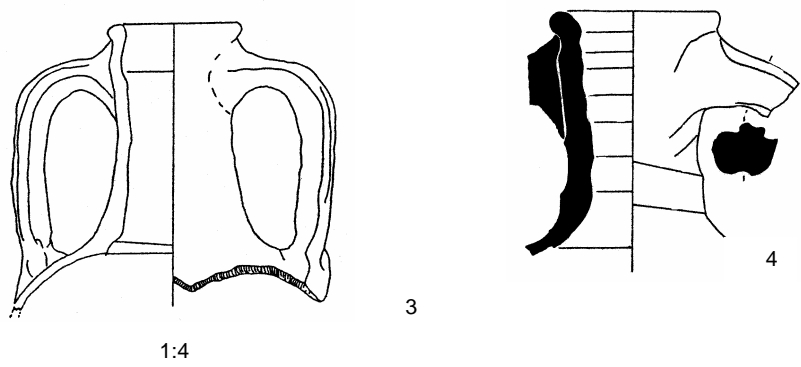
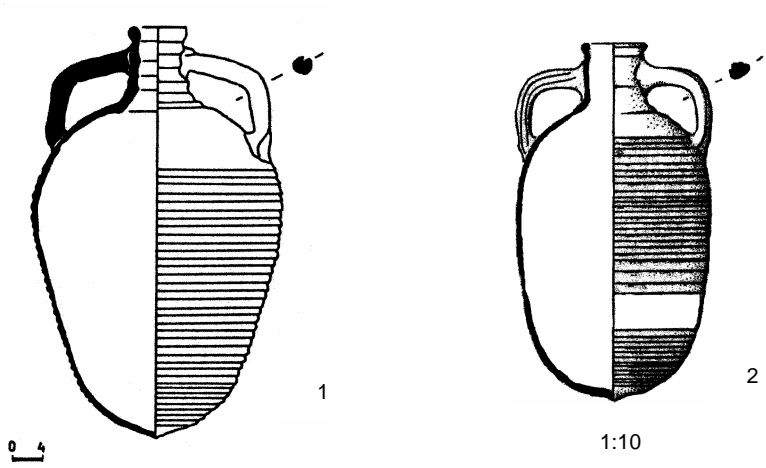

Figure 104 Late Roman 1 Amphorae. Scale 1:2

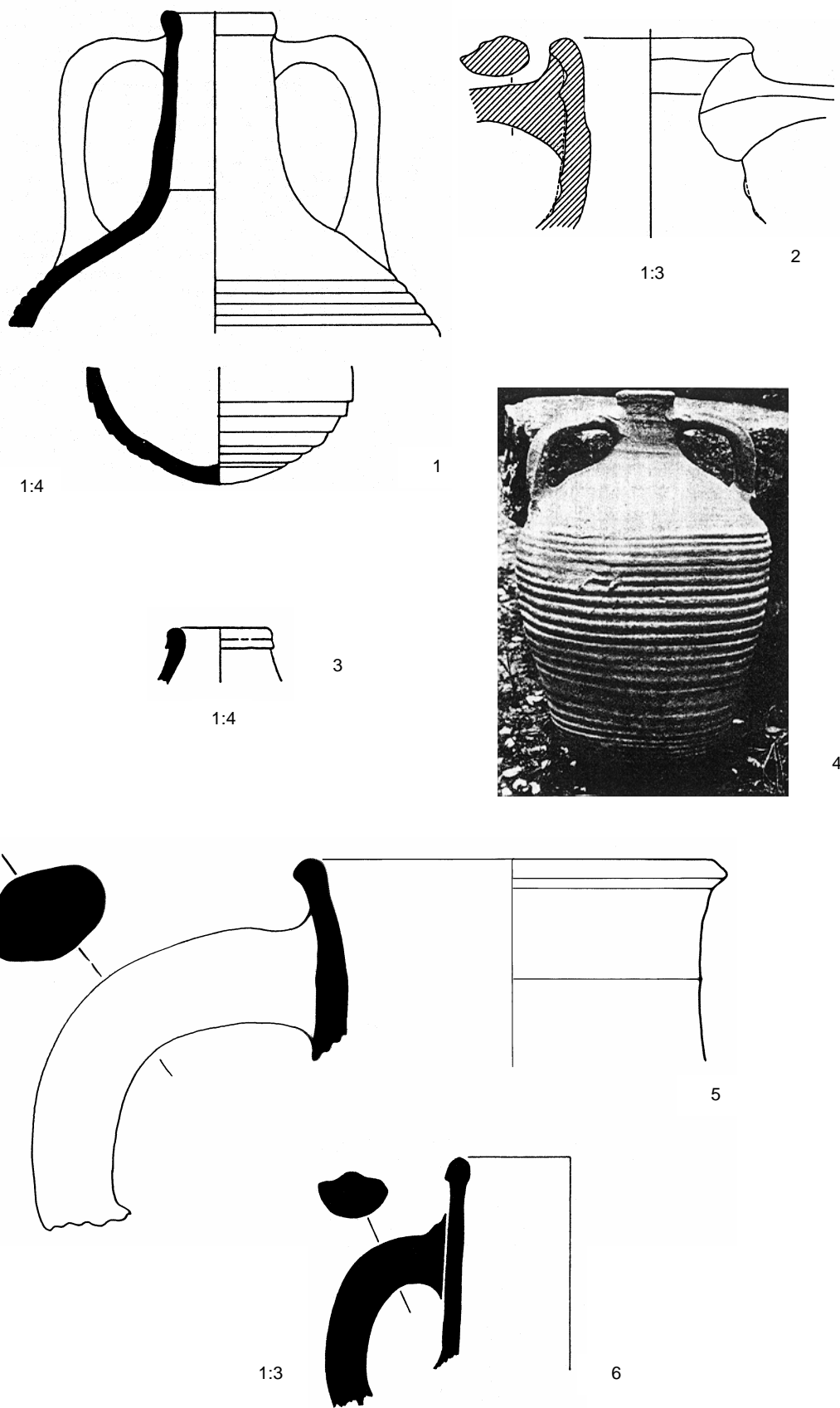

Figure 105 Late Roman 1 Amphorae. Scale 1:2

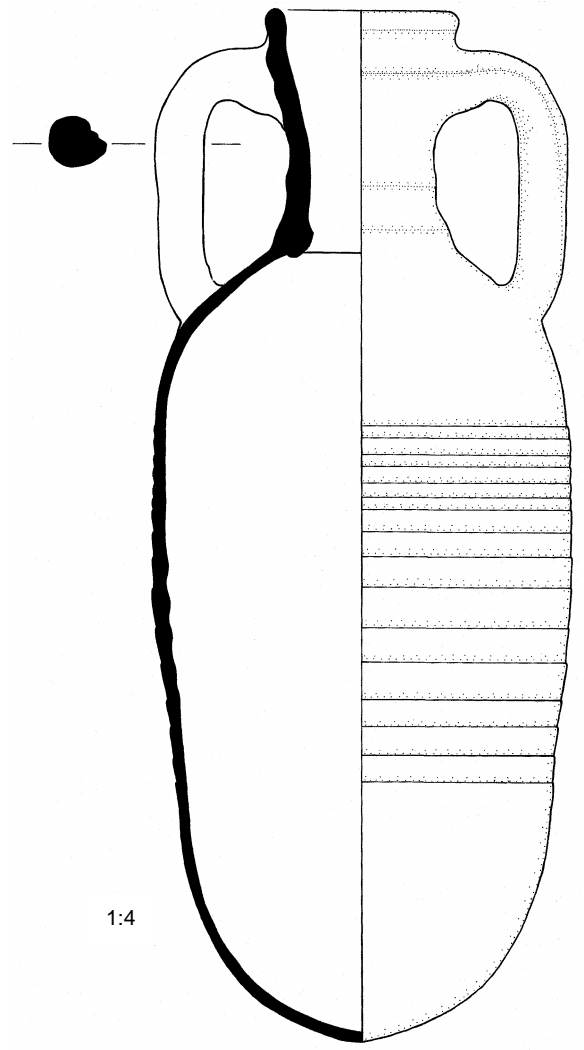

Figure 106 Late Roman 1 Amphora. Scale 1:2

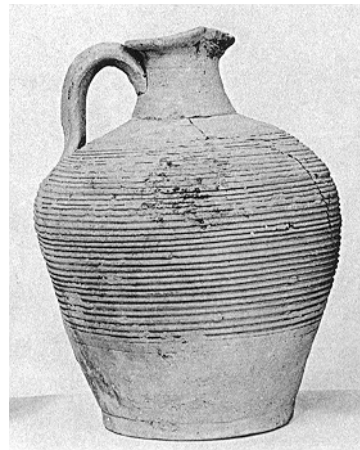
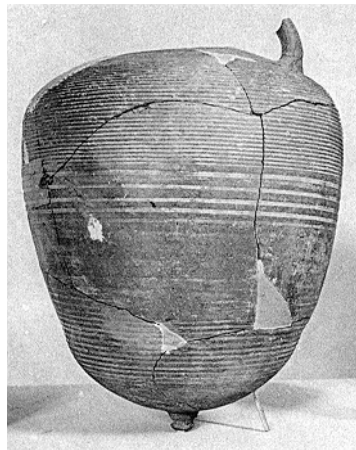
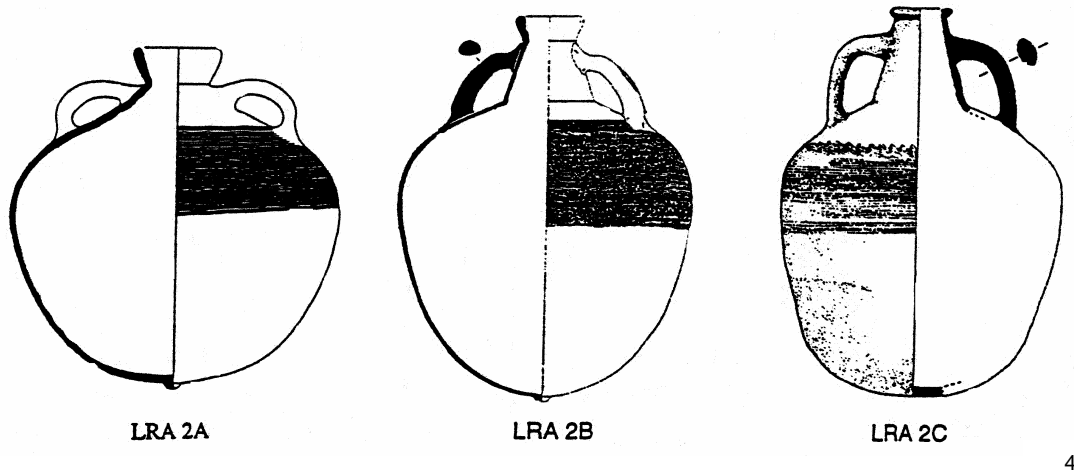
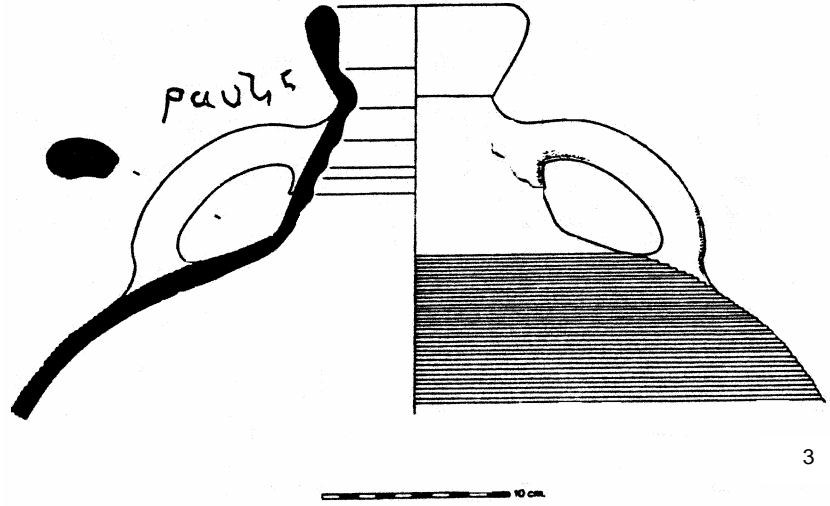
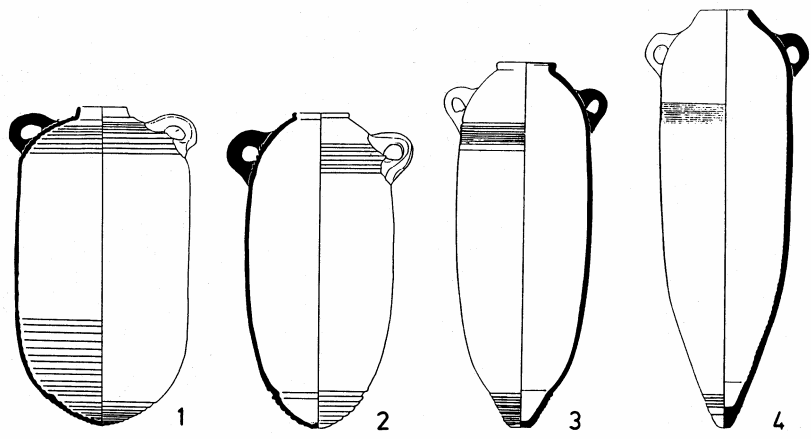
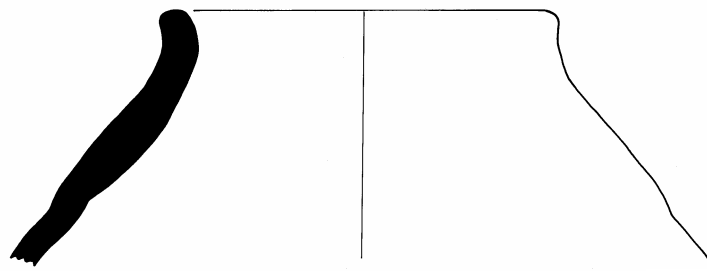

Figure 107 Late Roman 2 Amphorae. Scale 1:2



1



2

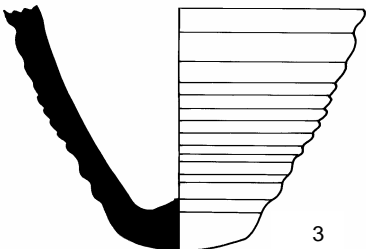

3

Figure 108 Late Roman 4 Amphorae. Scale 1:2

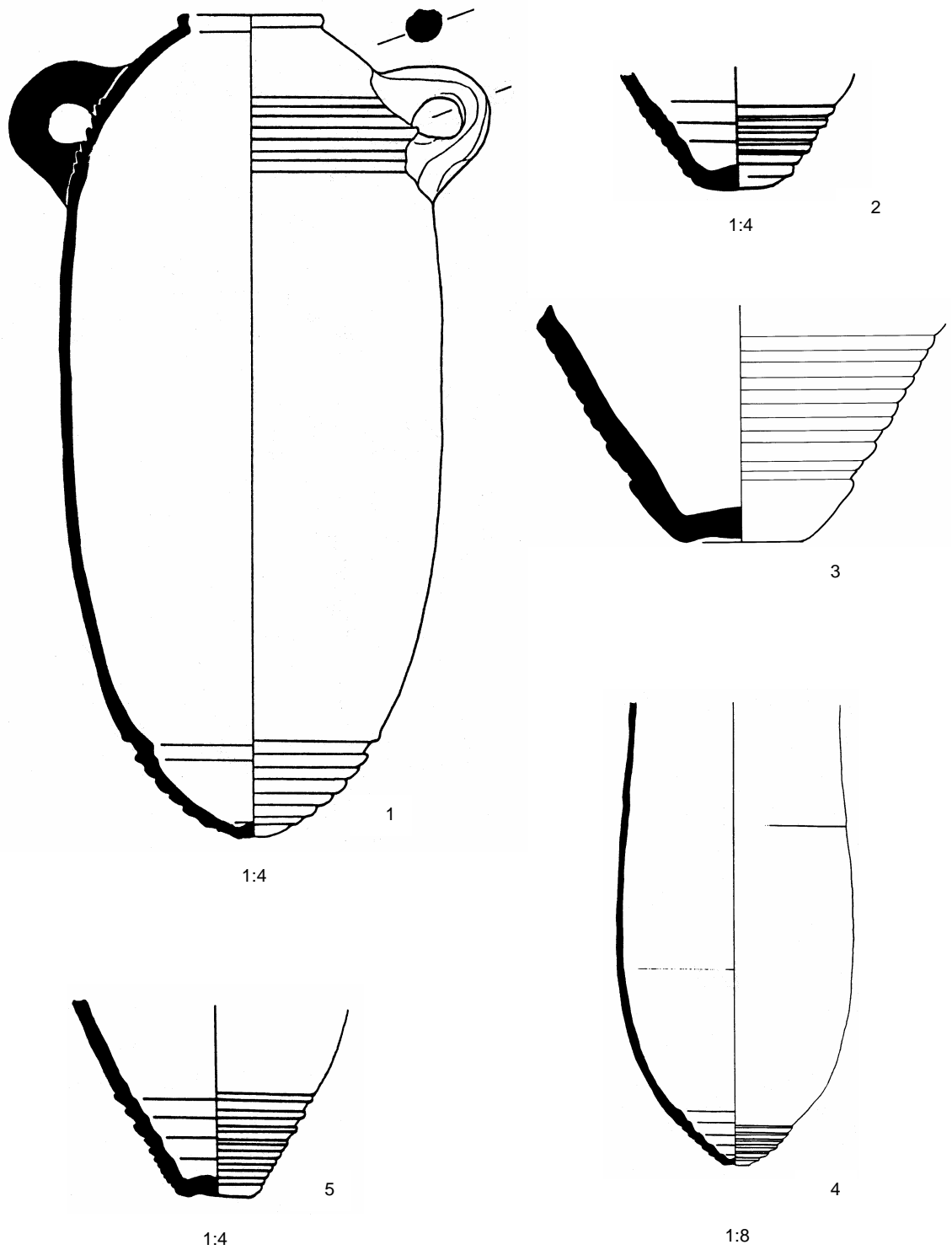

Figure 109 Late Roman 4 Amphorae. Scale 1:2

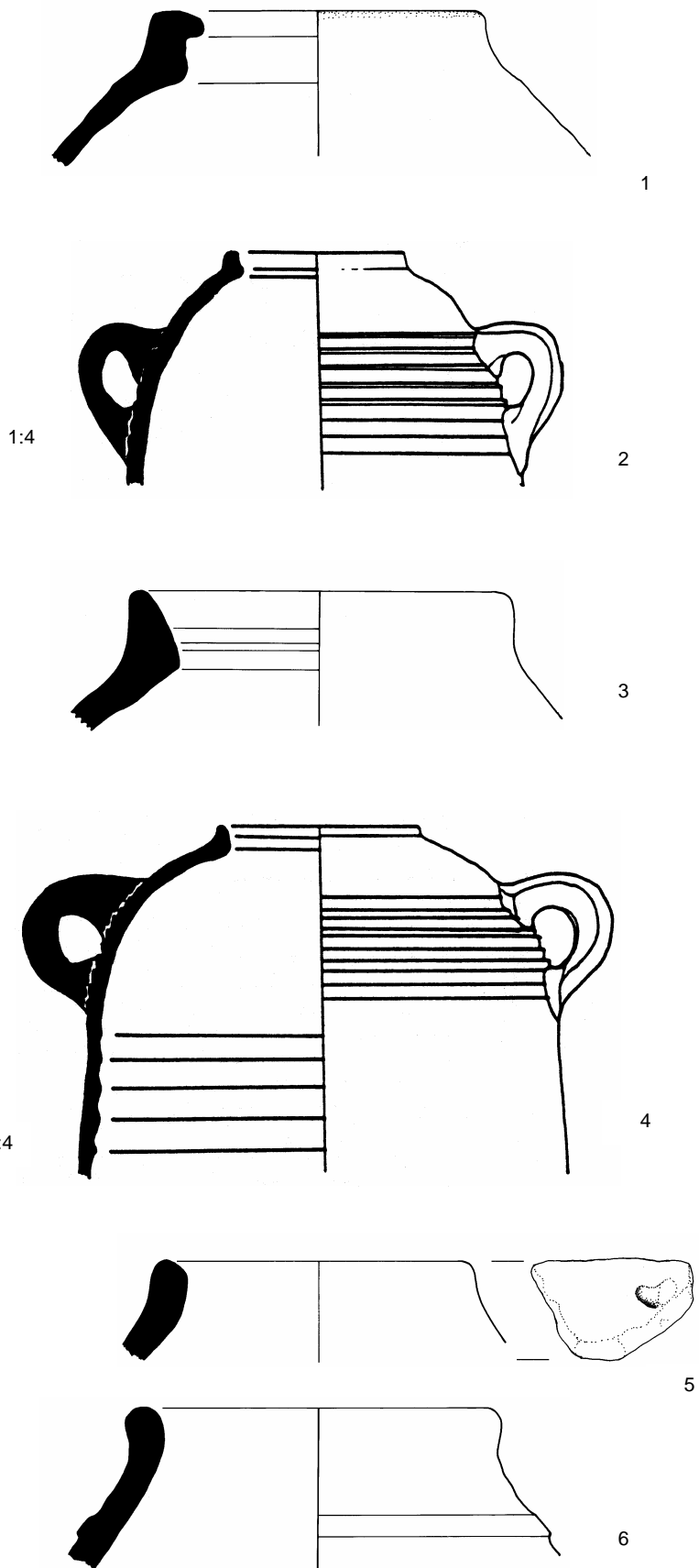

Figure 110 Late Roman 4 Amphorae. Scale 1:2

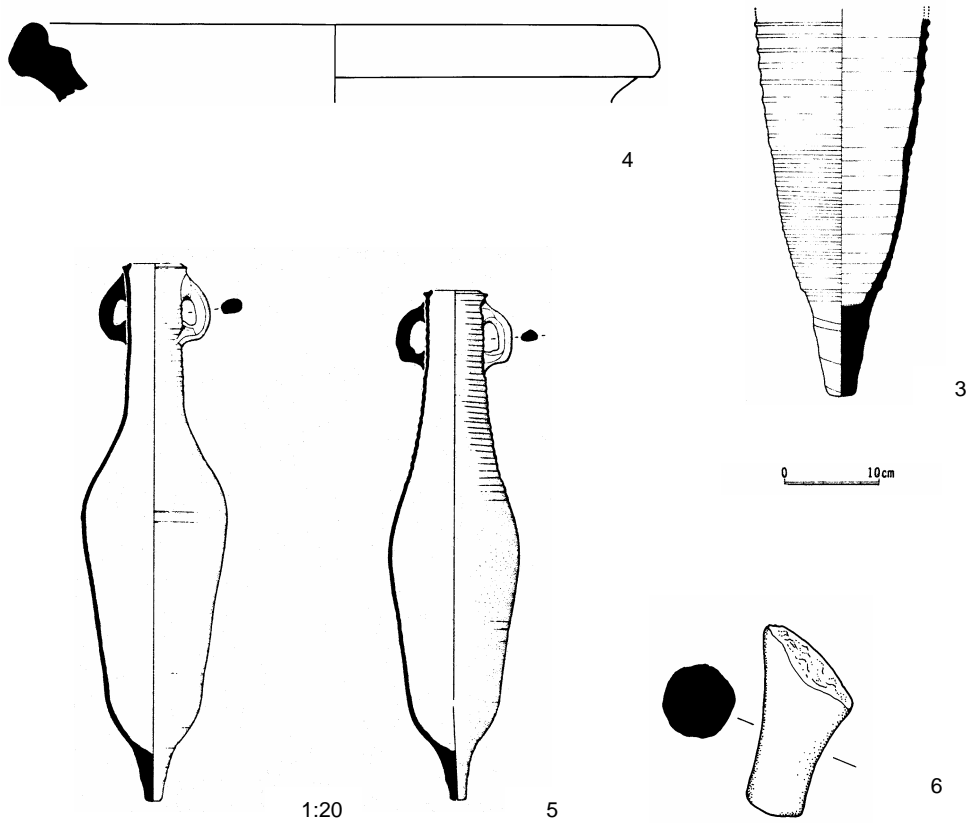
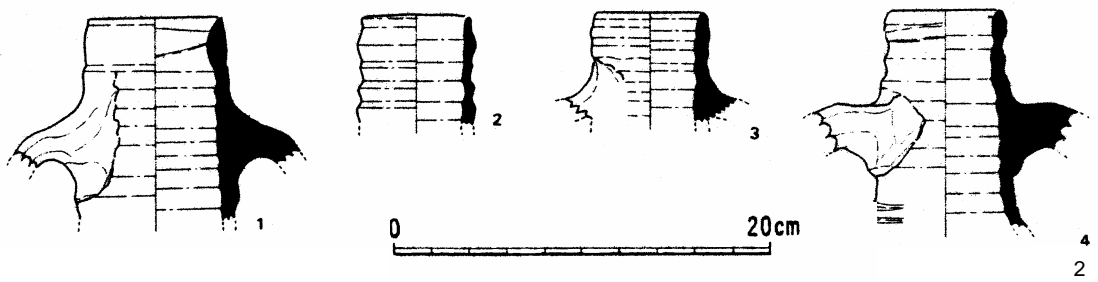
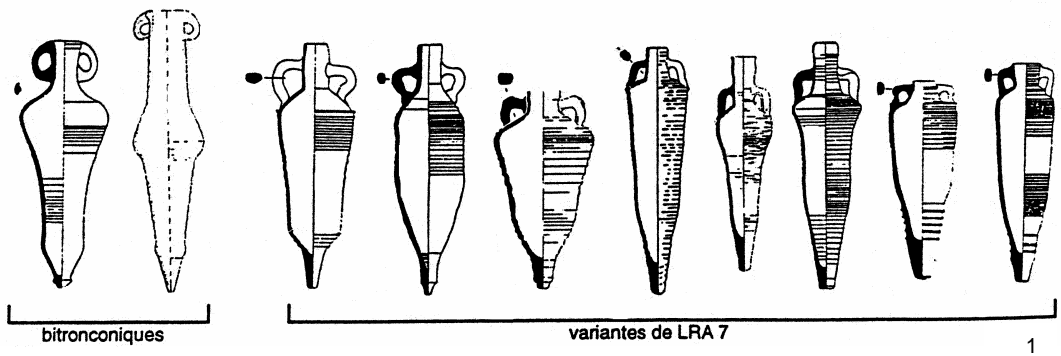

Figure 111 Late Roman 7 Amphorae. Scale 1:2

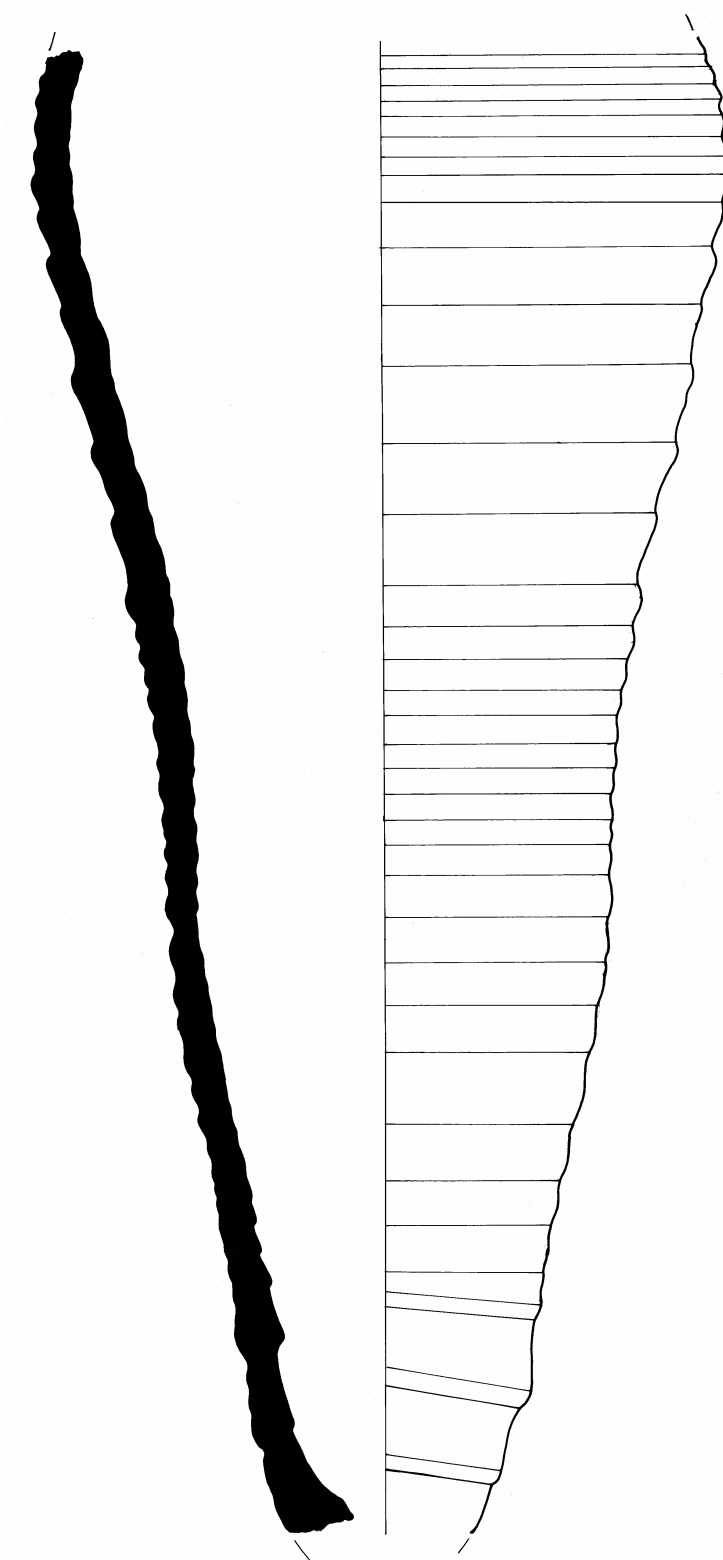

Figure 112 Late Roman 7 Amphora. Scale 1:2

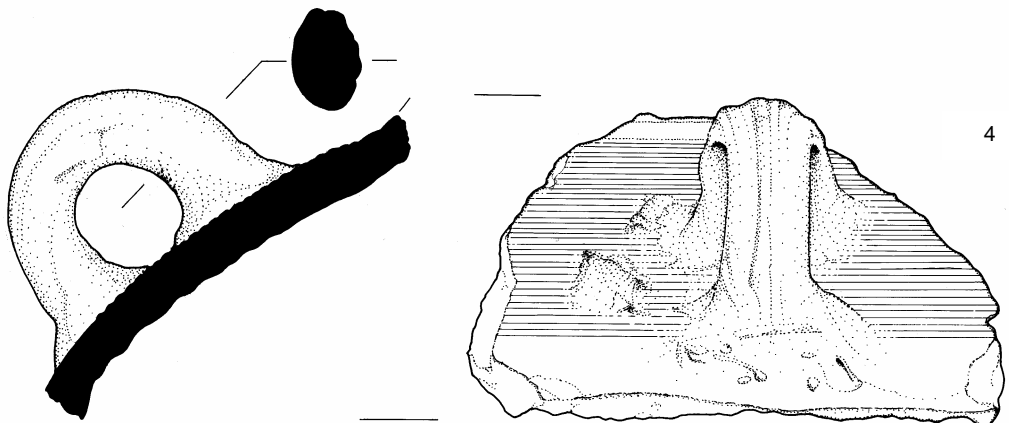
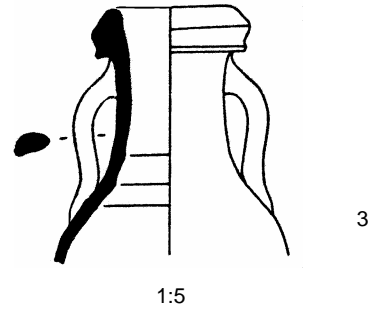
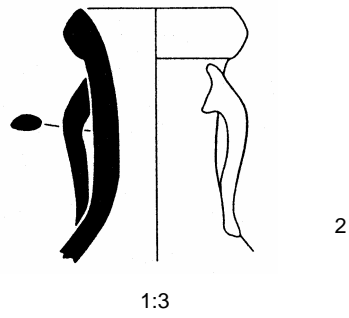
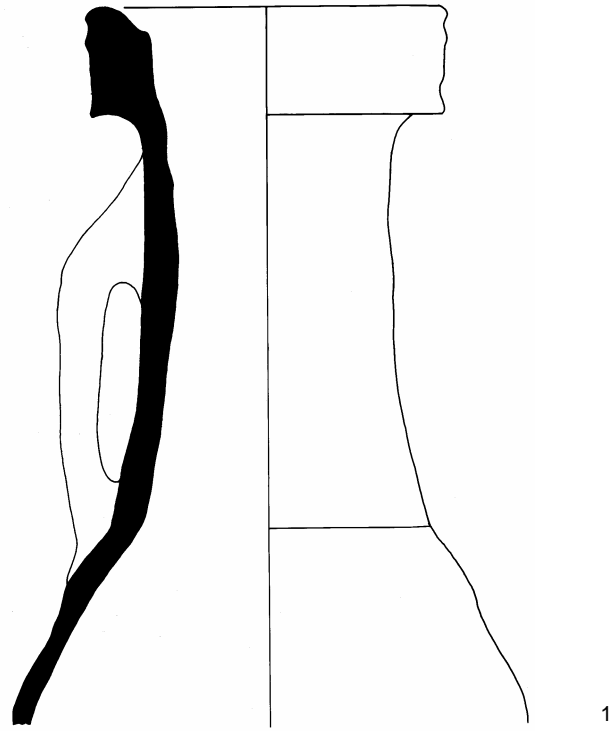

Figure 113 Late Roman 8 & 5/6 Amphorae. Scale 1:2

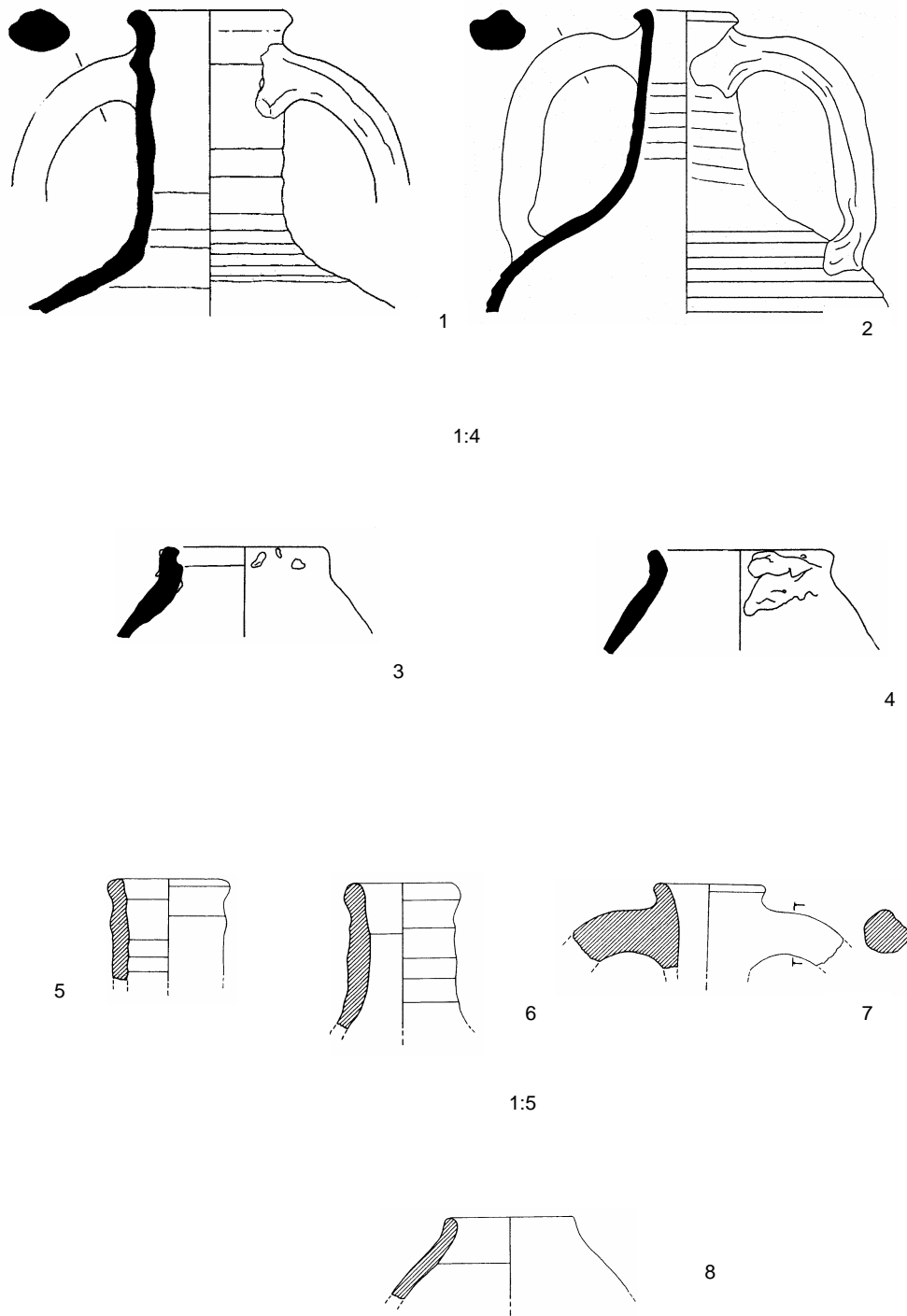

Figure 114 Late Roman 1 & 4 Amphorae from Kalavastos-Kopetra and the Garrison's Camp.

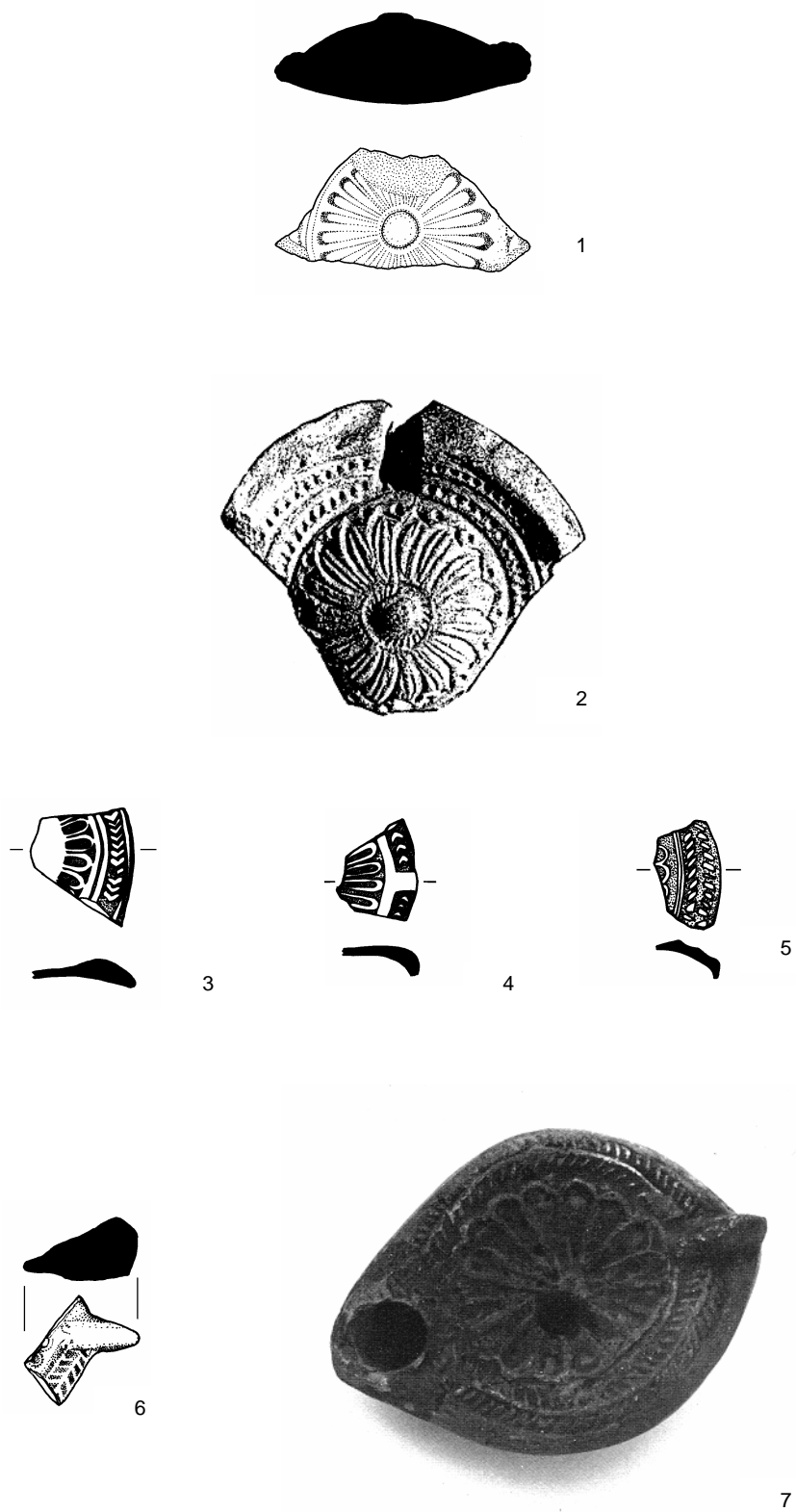

Figure 115 Group 1 Roman Lamps. Scale 1:2

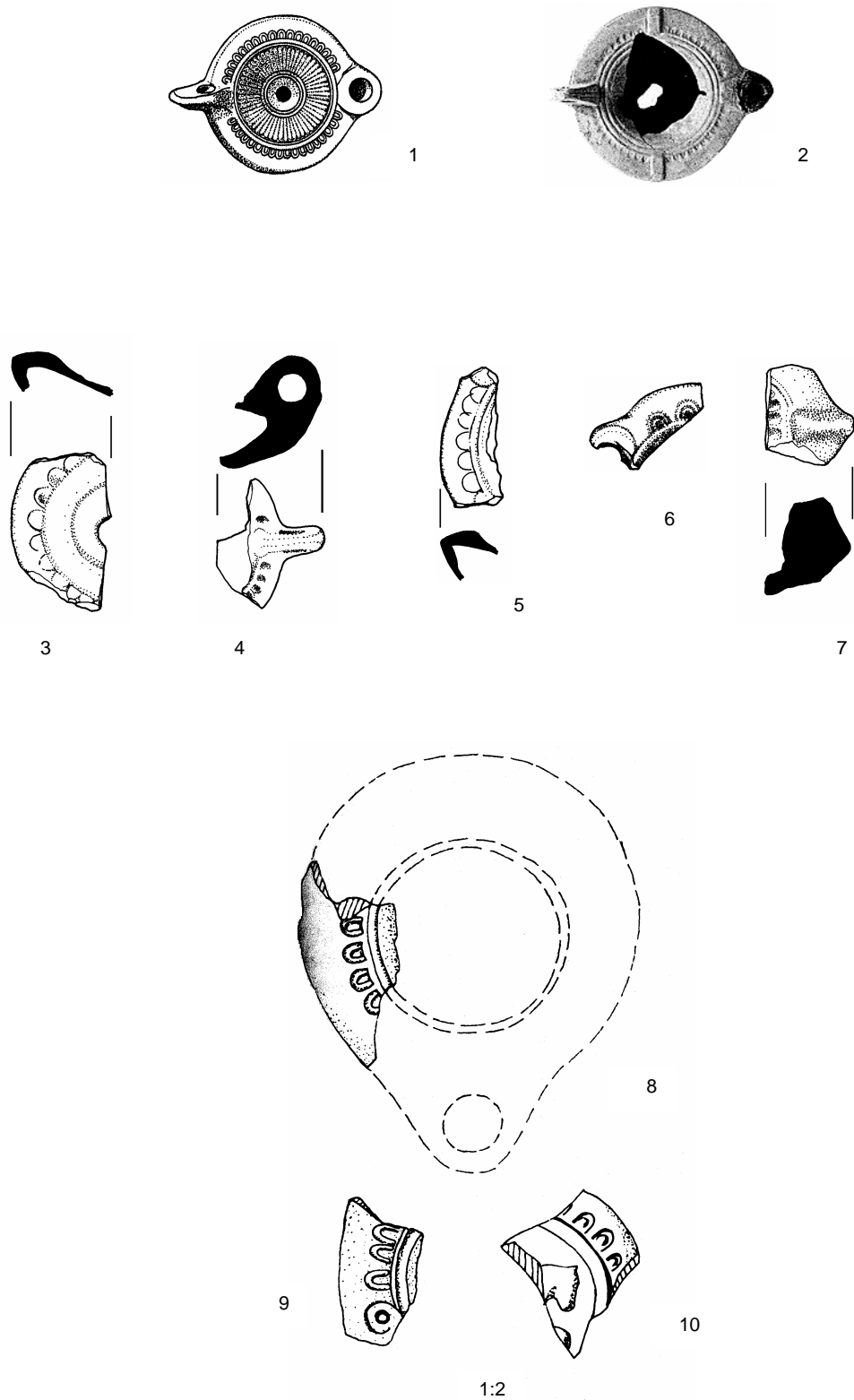

Figure 116 Group 2 Roman Lamps. Scale 1:2

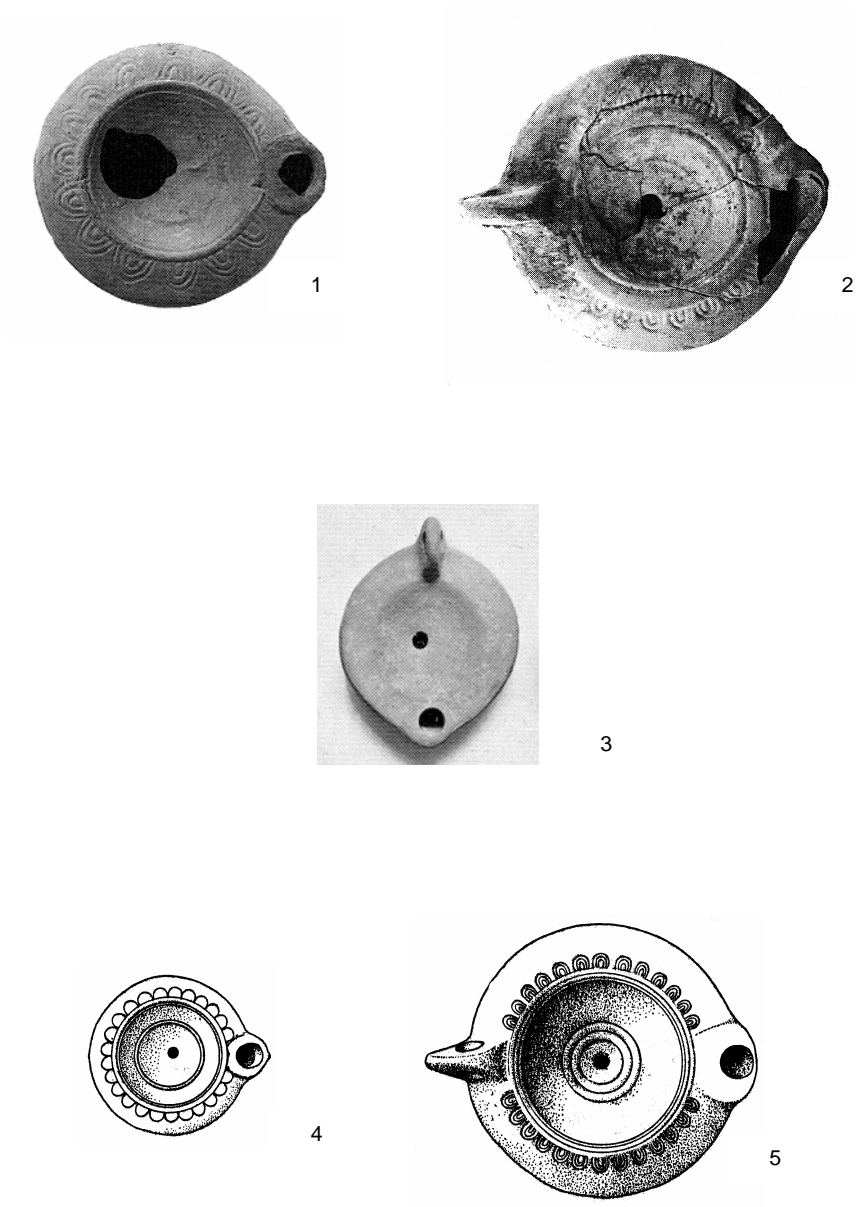

Figure 117 Group 2 Roman Lamps. Scale 1:2

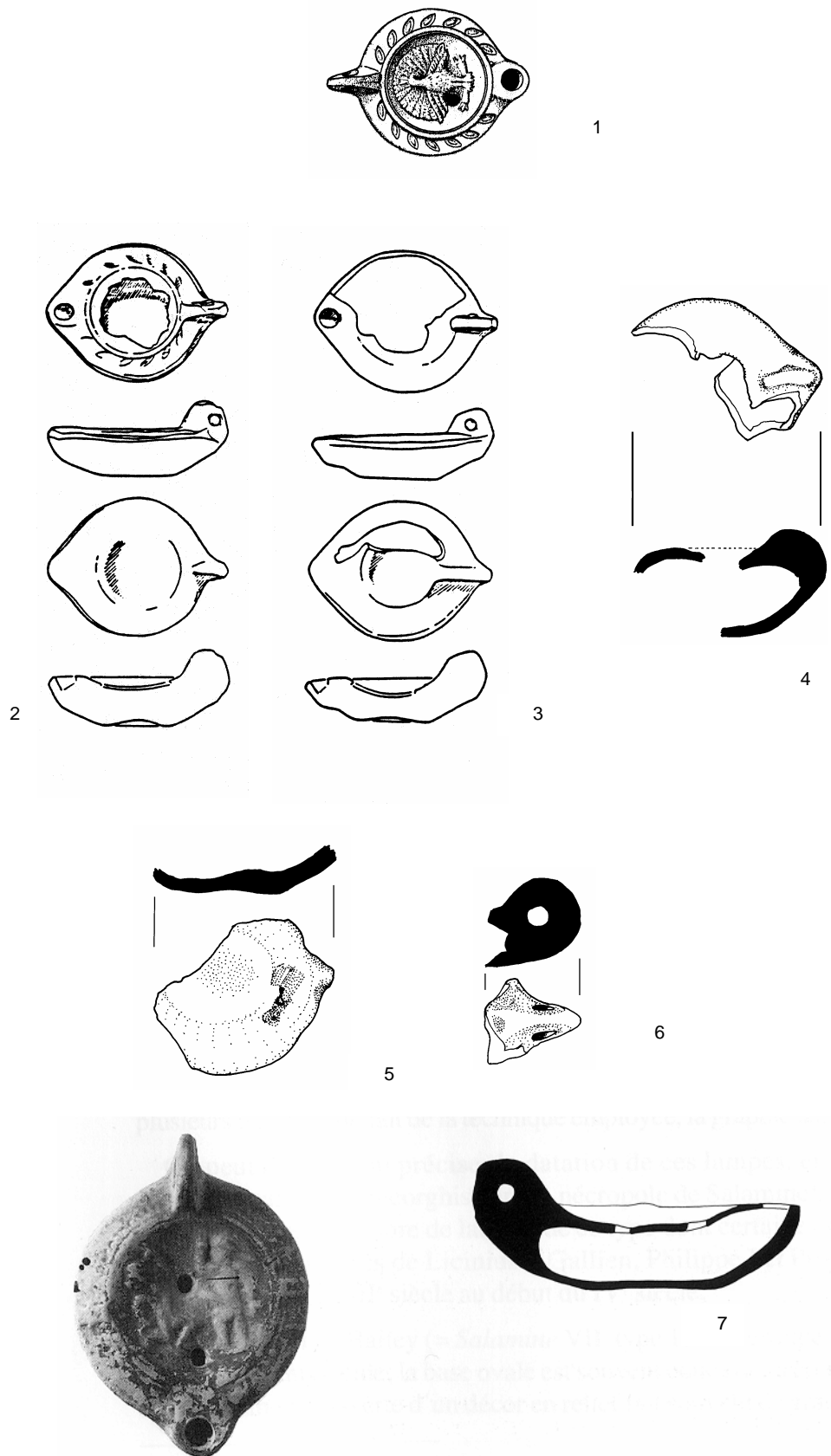

Figure 118 Group 3 Roman Lamps. Scale 1:2

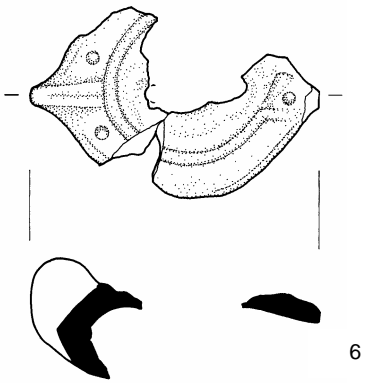
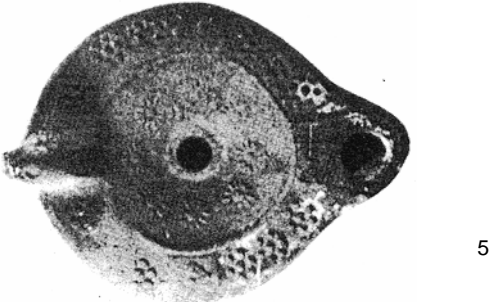
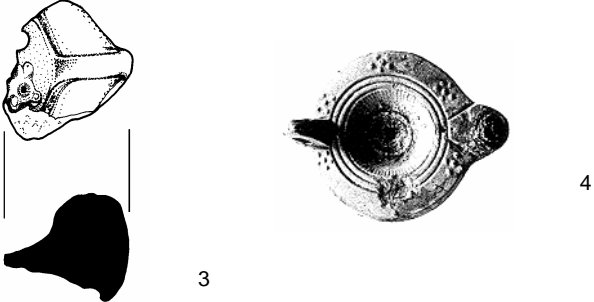
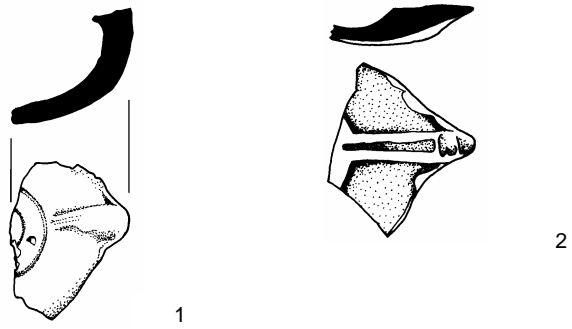

Figure 119 Group 3 Roman Lamps. Scale 1:2

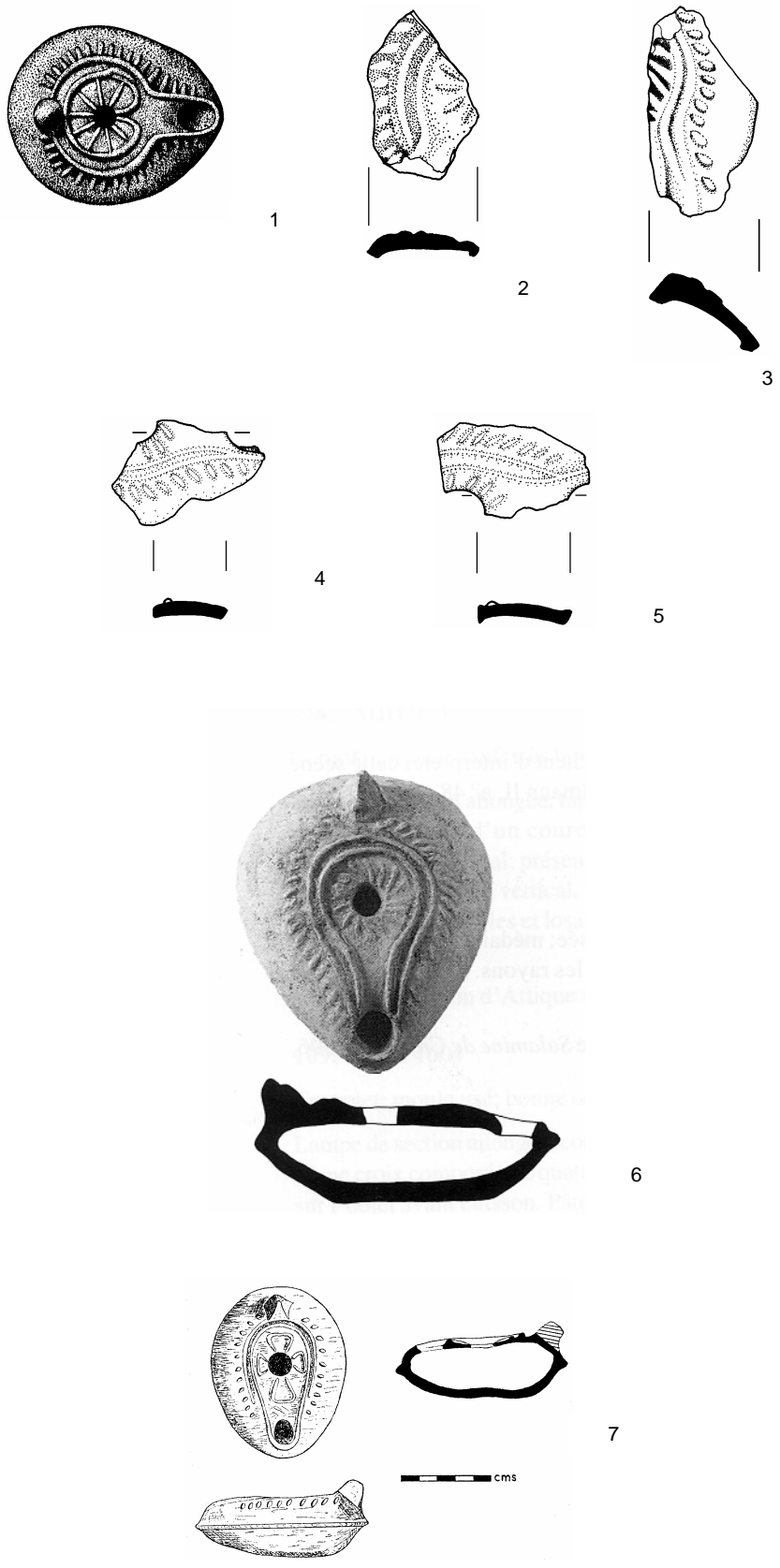

Figure 120 Group 4 Roman Lamps. Scale 1:2

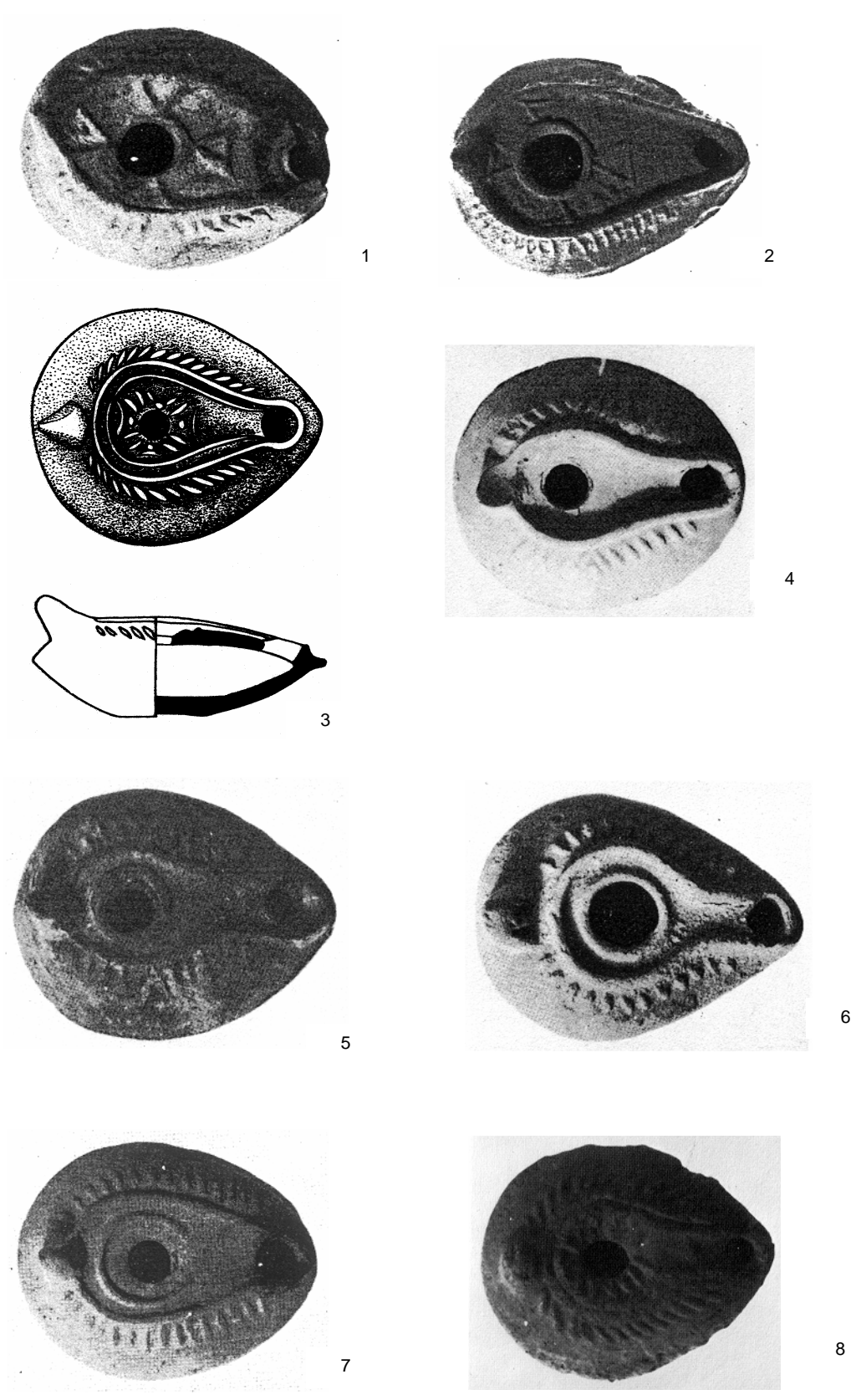

Figure 121 Group 4 Roman Lamps.

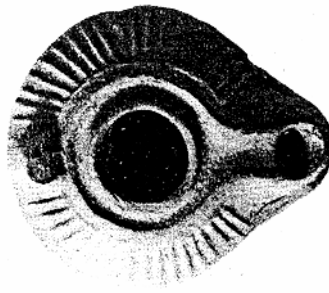
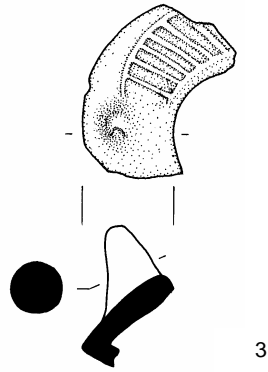
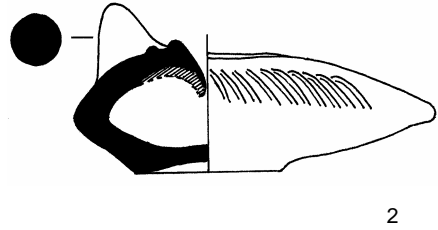
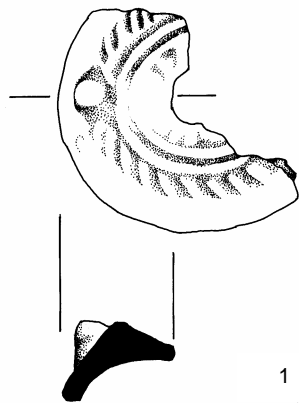

Figure 122 Group 4 Roman Lamps. Scale 1:2

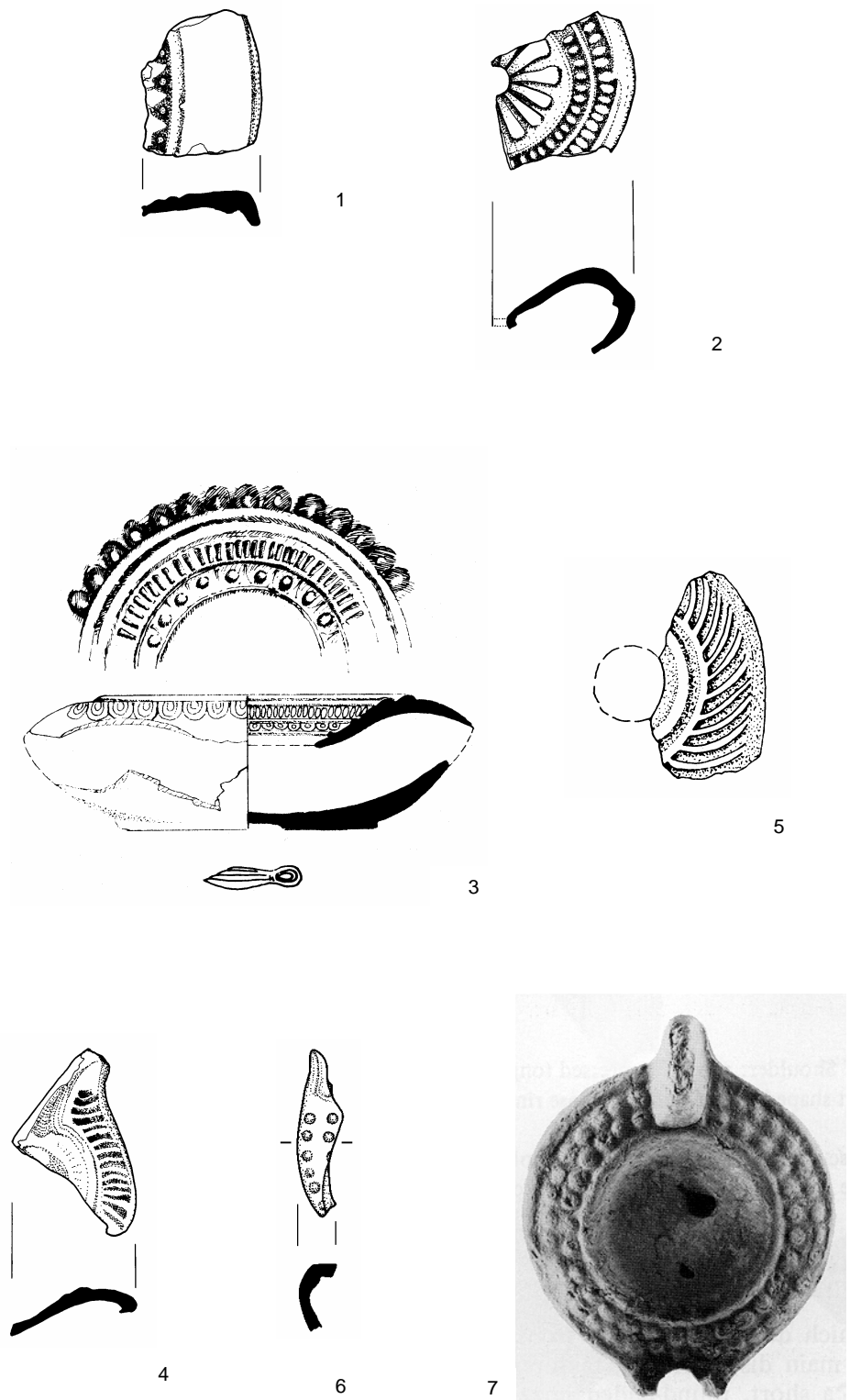
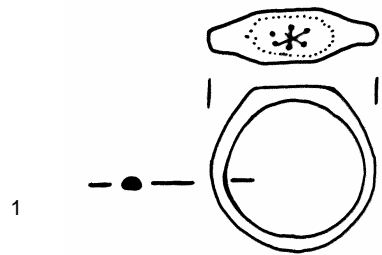

Figure 123 Group 5 Roman Lamps. Scale 1:2



2



1

3

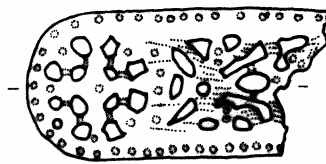

4

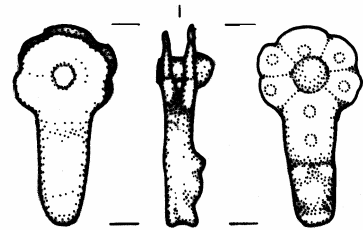

6

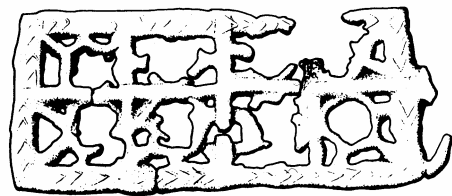

1:1

5

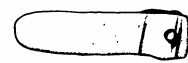

1:1

7



Figure 124 Metal Small Finds. Scale 1:1

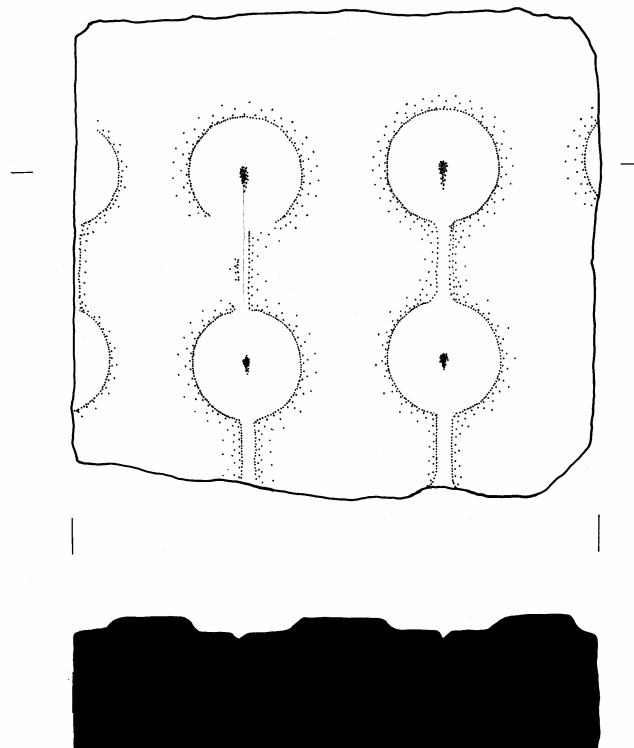
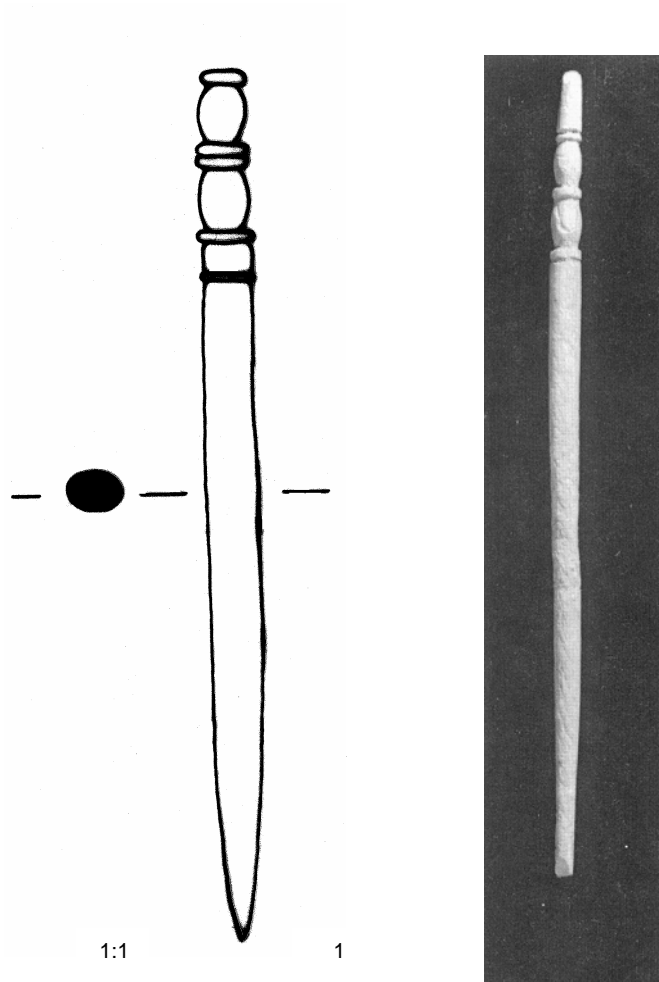

Figure 125 Inv.279 and Inv.488

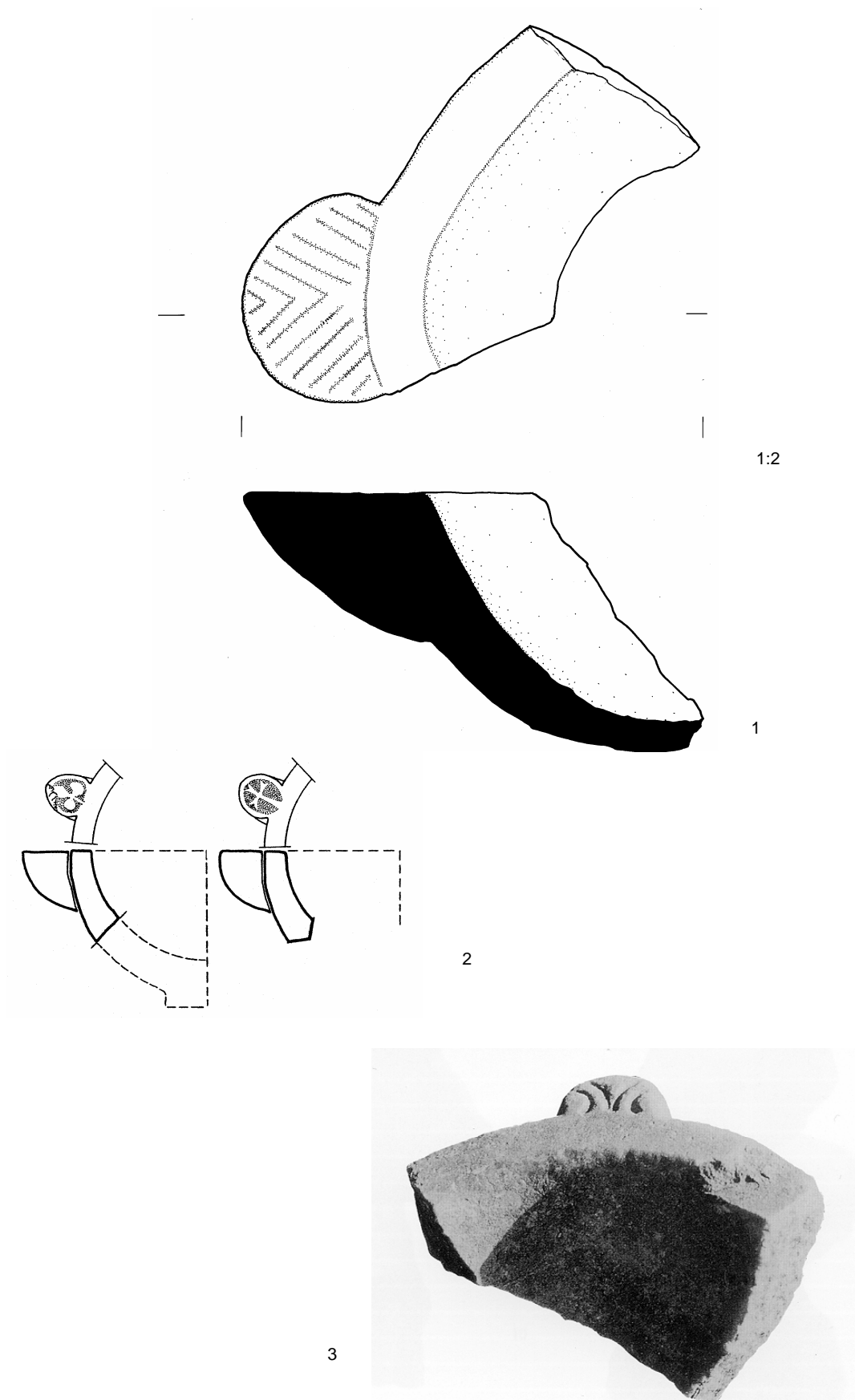
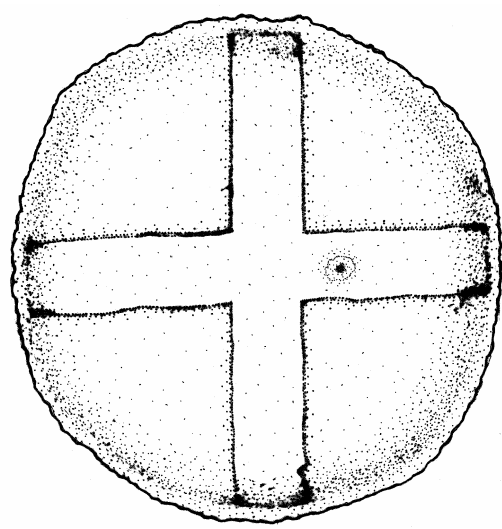
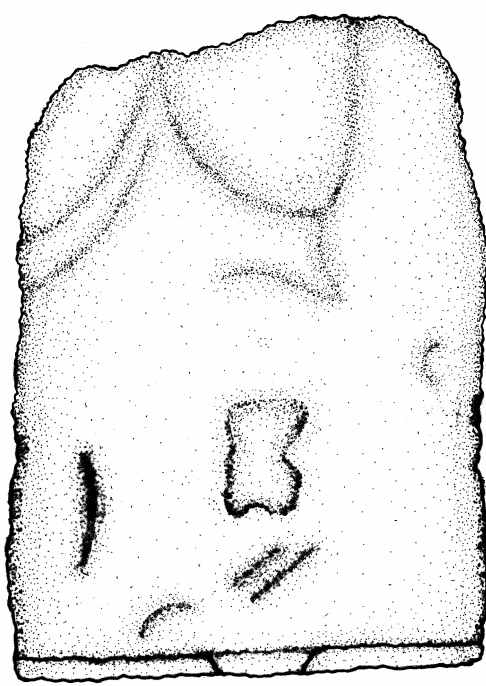
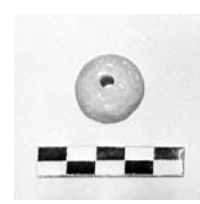

Figure 126 Stone Basins



1

1:2



2



3



4

Figure 127 Inv.494 and spindle whorls

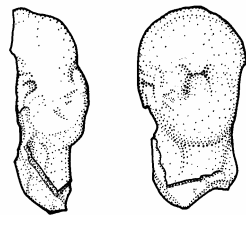

1

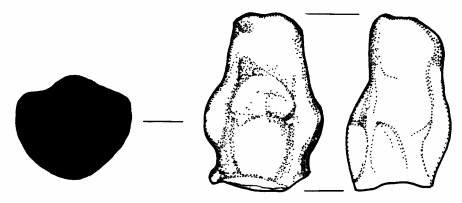

2

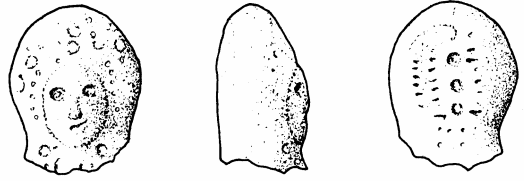

3



4

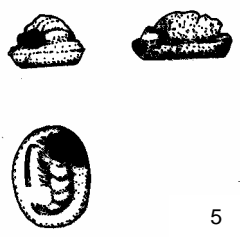

5

Figure 128 Terracotta Small Finds and Inv.199. Scale 1:1

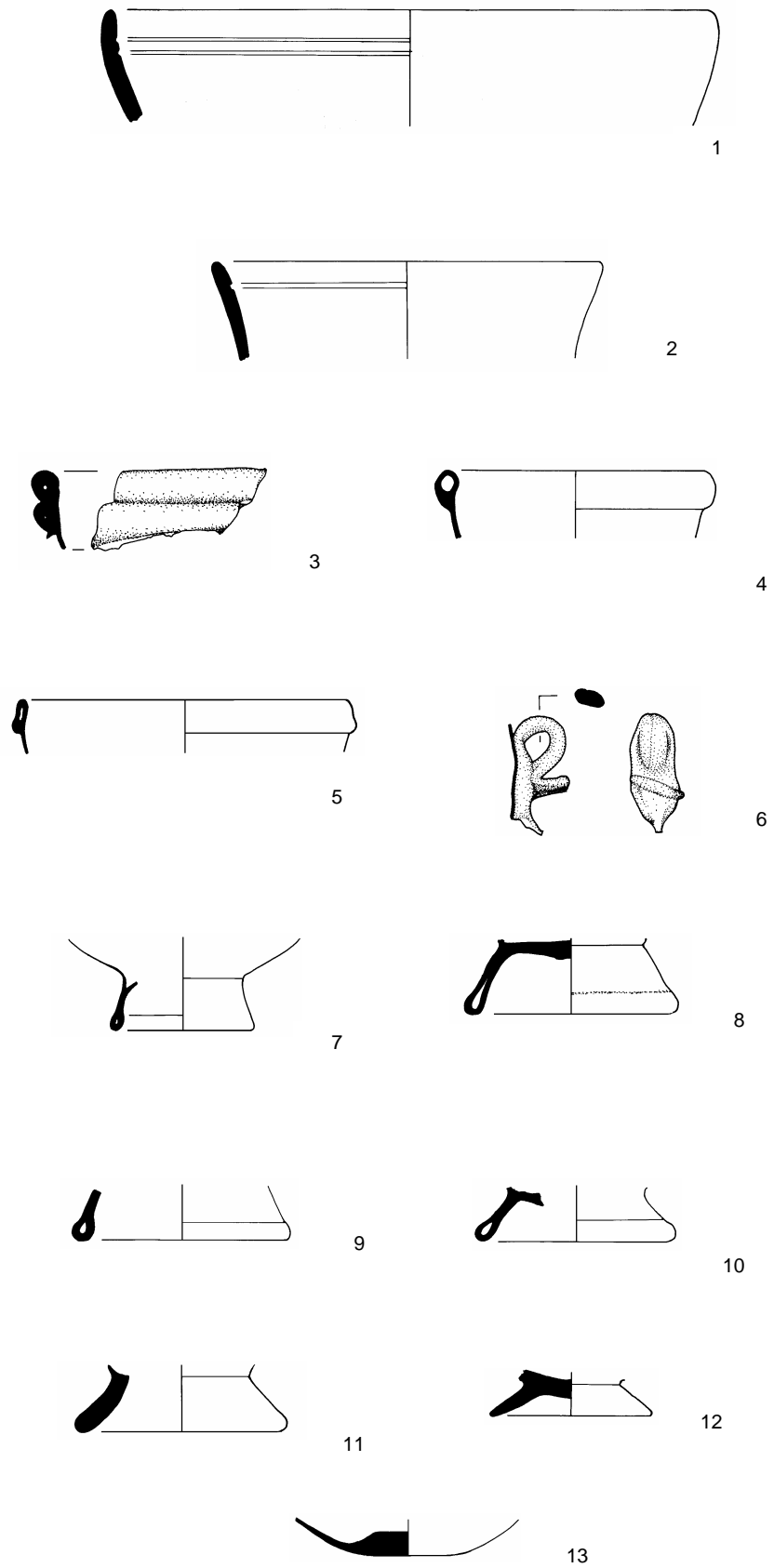

Figure 129 Glass Deep Bowls Scale 1:2

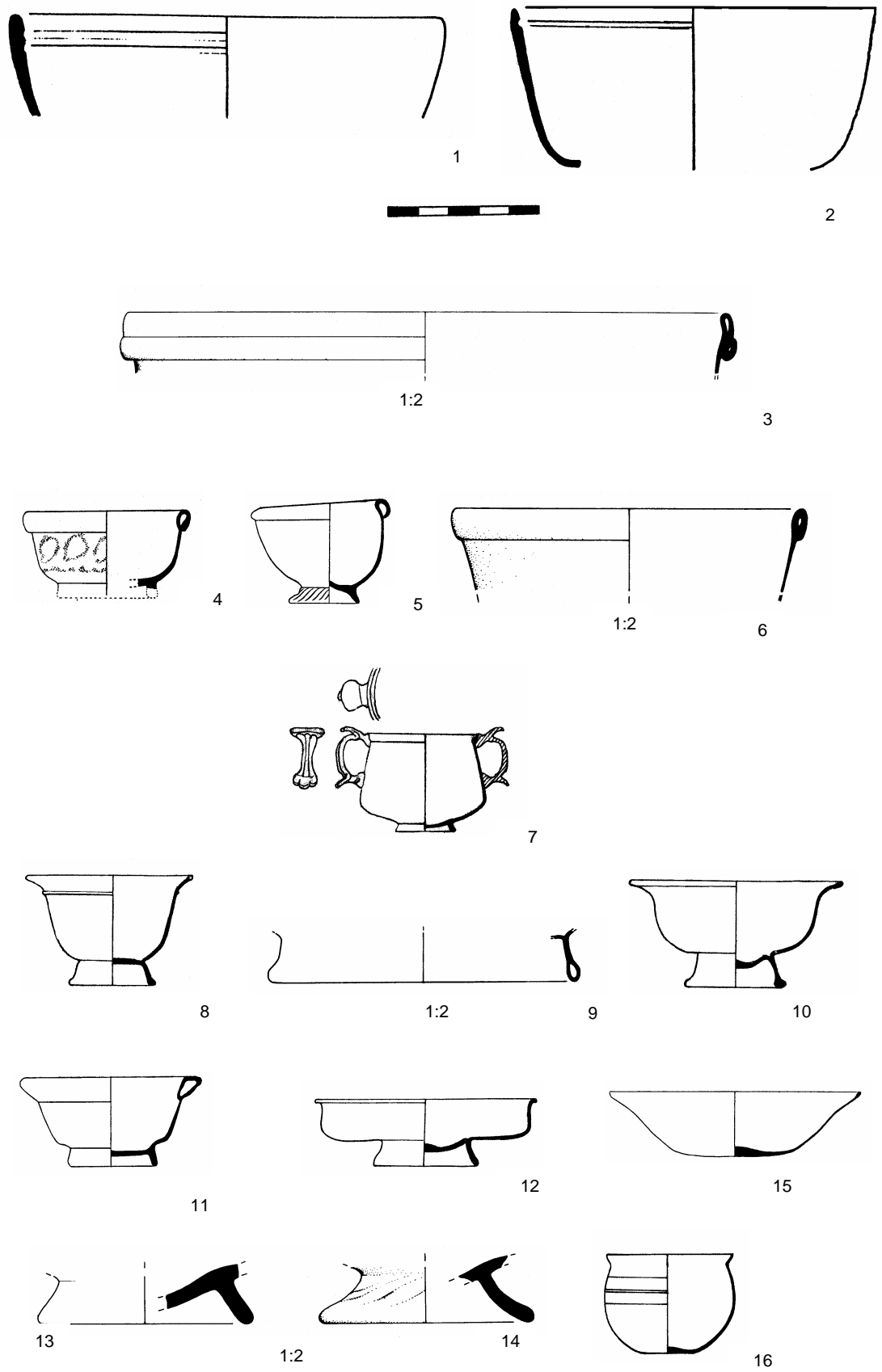

Figure 130 Glass Deep Bowls. Scale 1:4

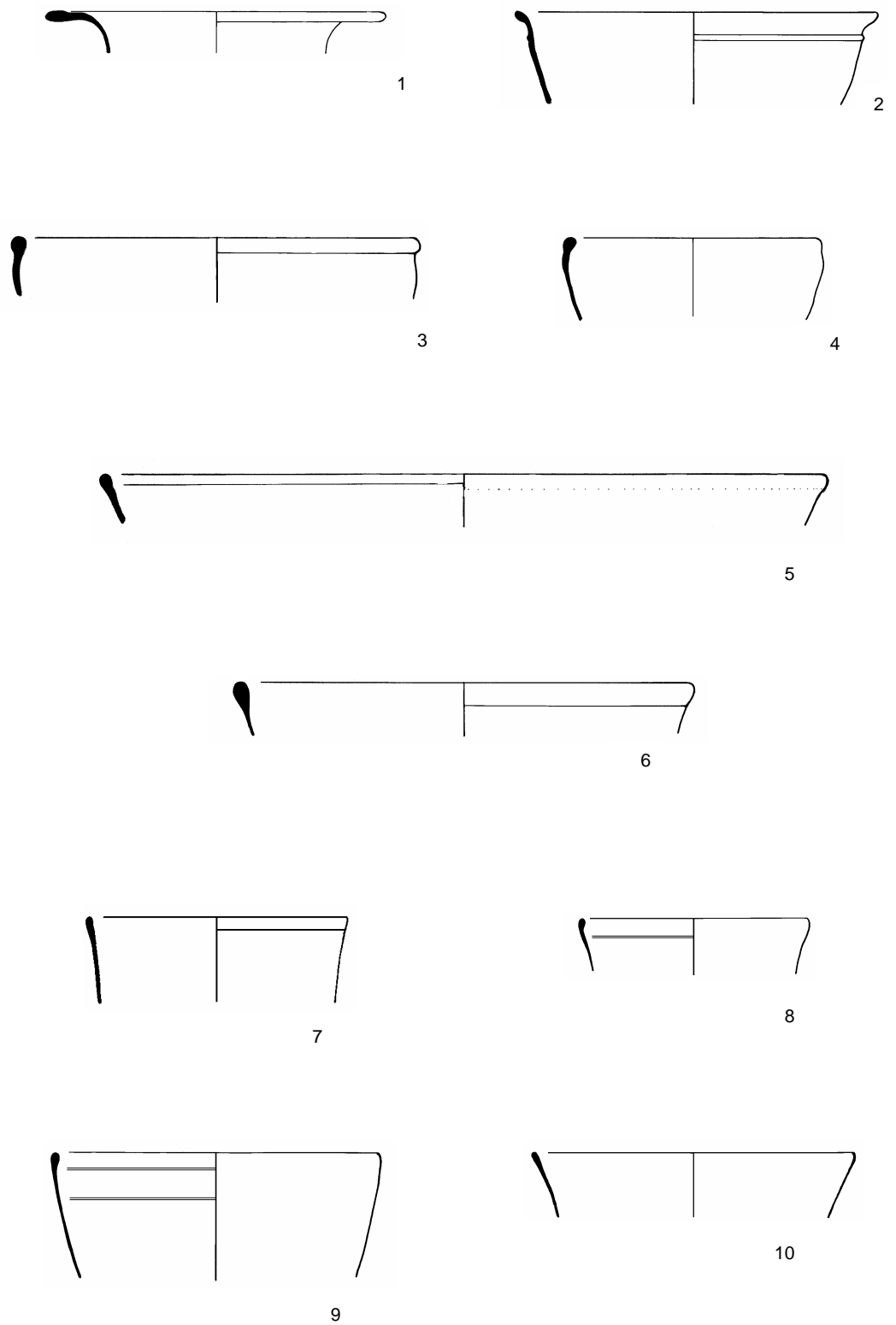

Figure 131 Glass Deep Bowls. Scale 1:2

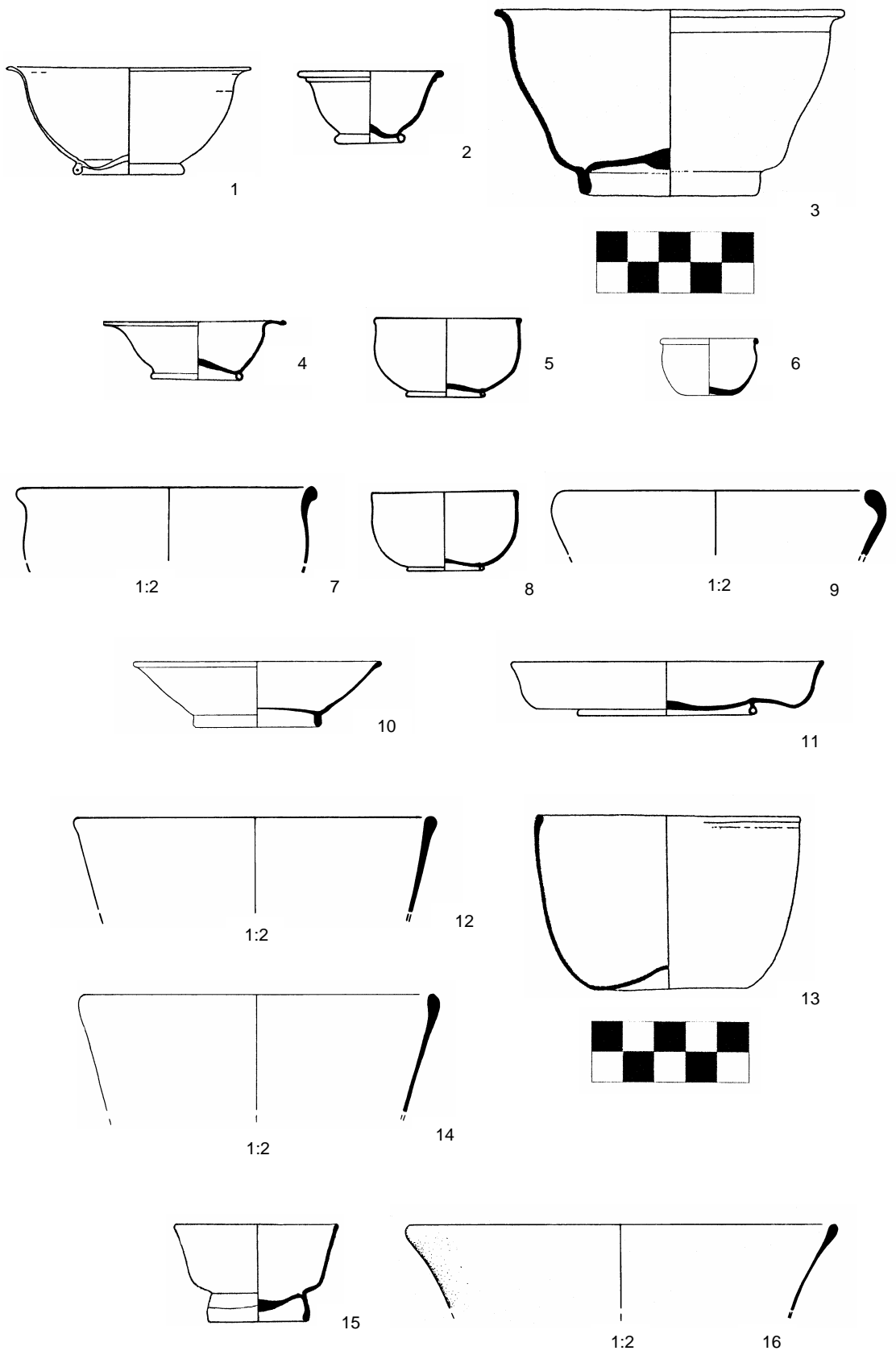

Figure 132 Glass Deep Bowls. Scale 1:4

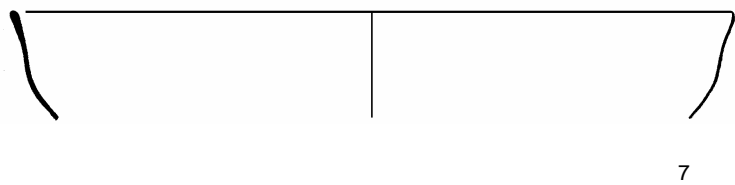
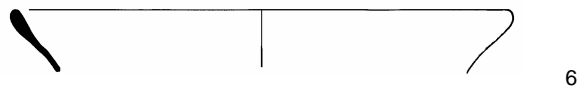
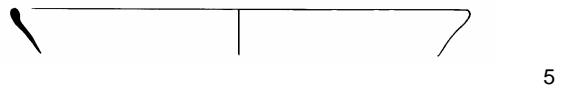
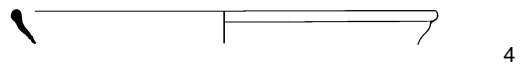
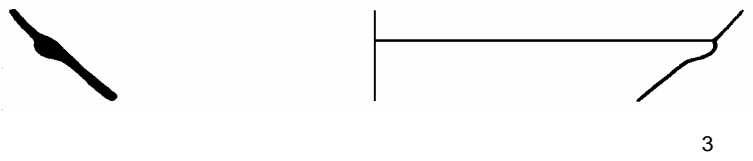
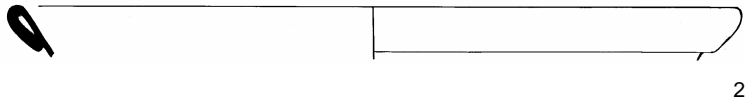
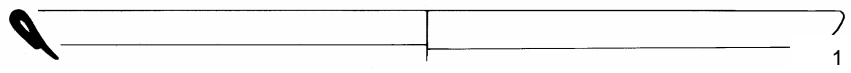

Figure 133 Glass Shallow Bowls. Scale 1:2

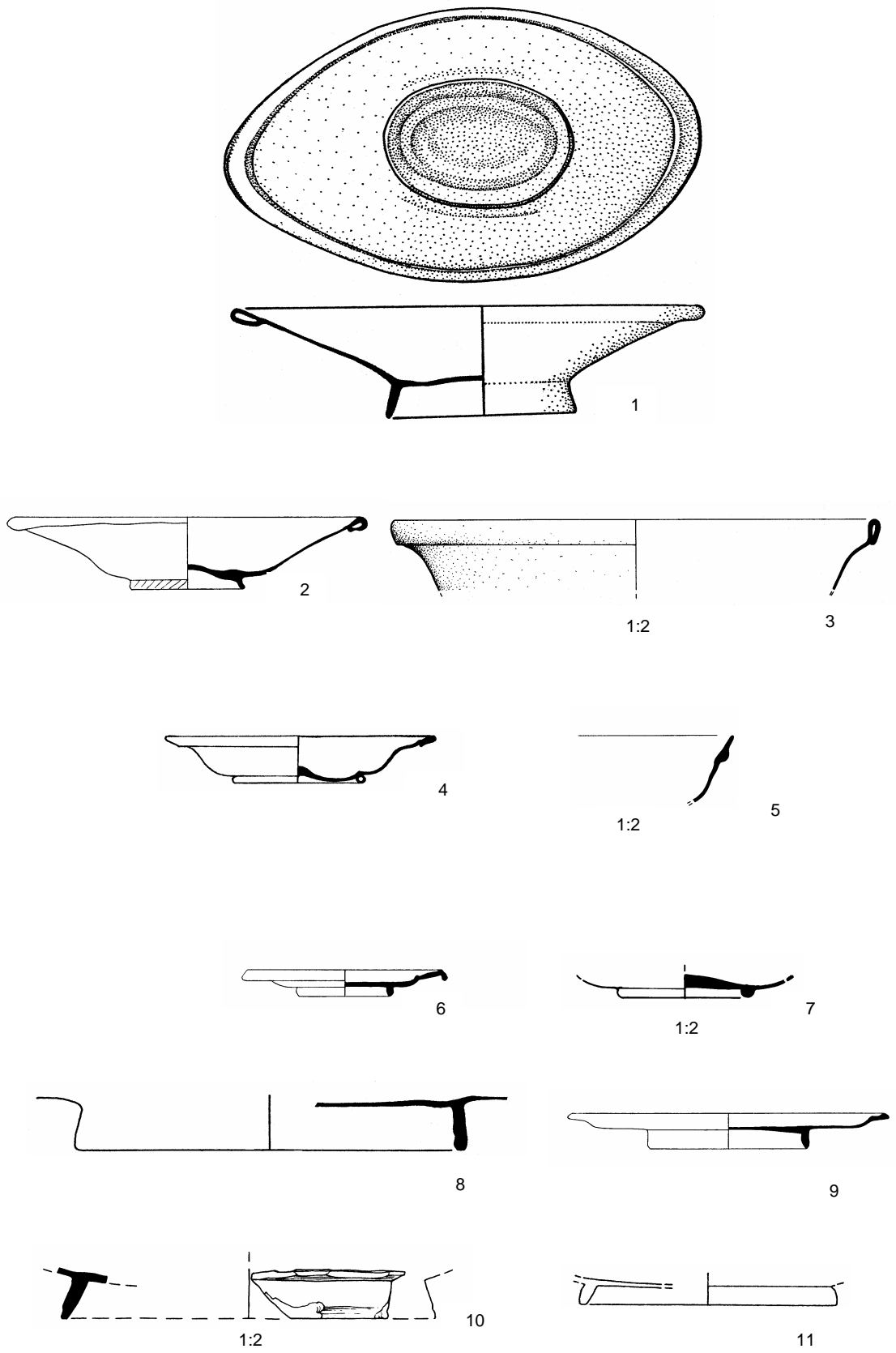
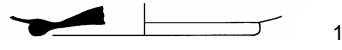
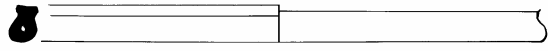

Figure 134 Glass Shallow Bowls and Plates. Scale 1:4



1



2

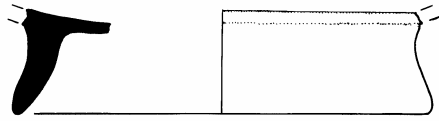

3

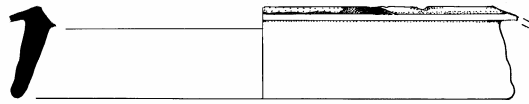

4



5

Figure 135 Glass Plates. Scale 1:2

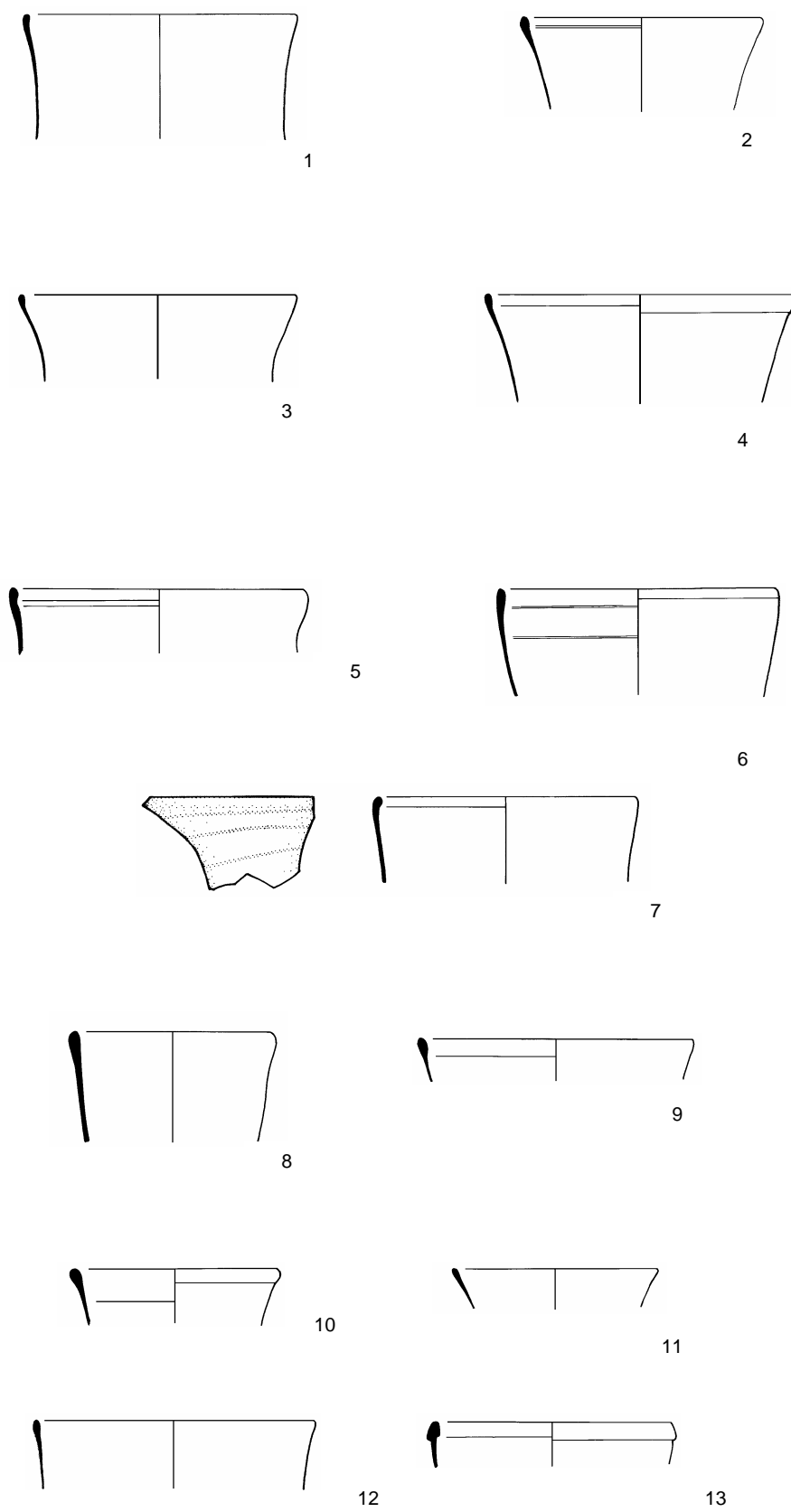

Figure 136 Glass Beakers. Scale 1:2

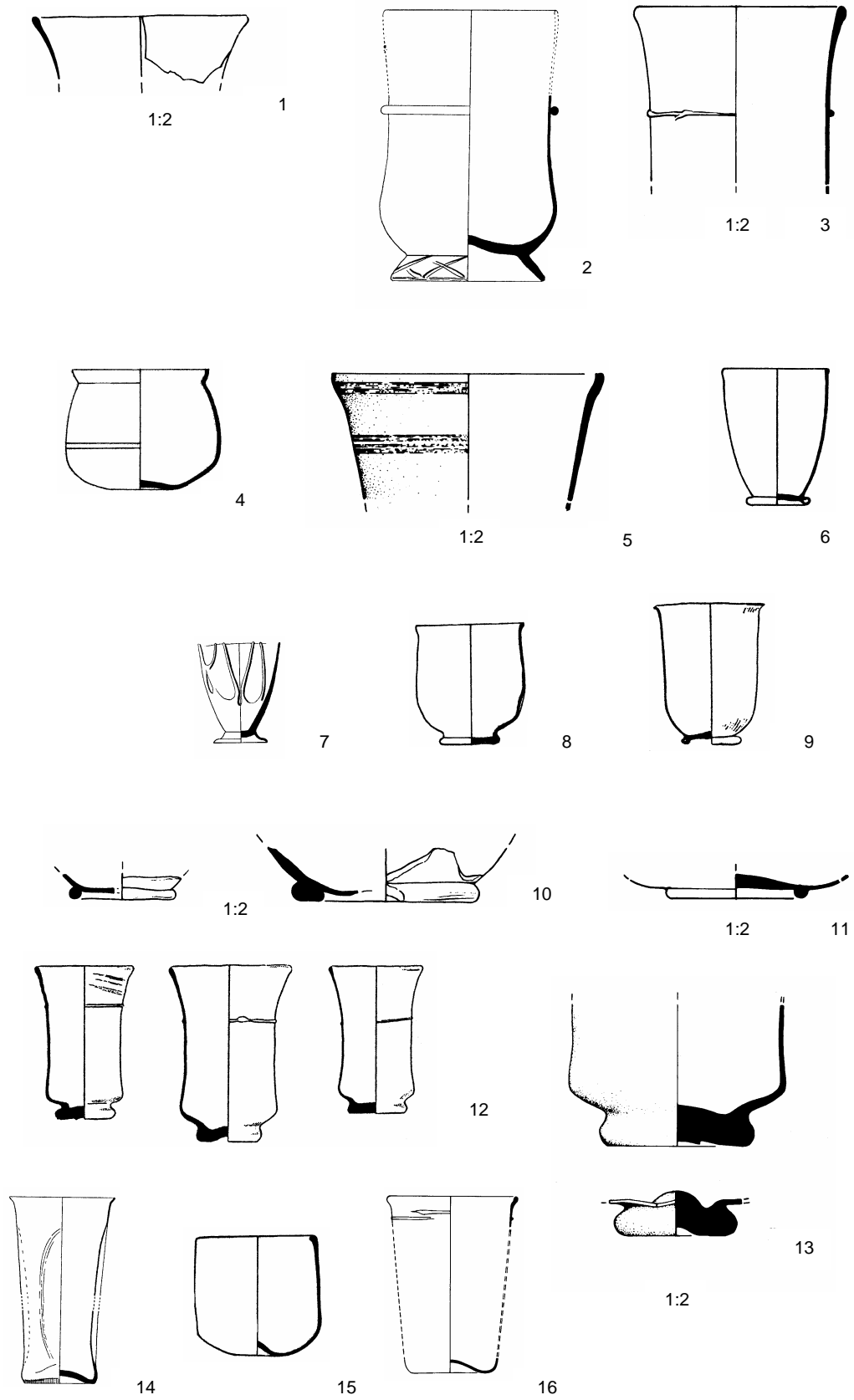

Figure 137 Glass Beakers. Scale 1:4

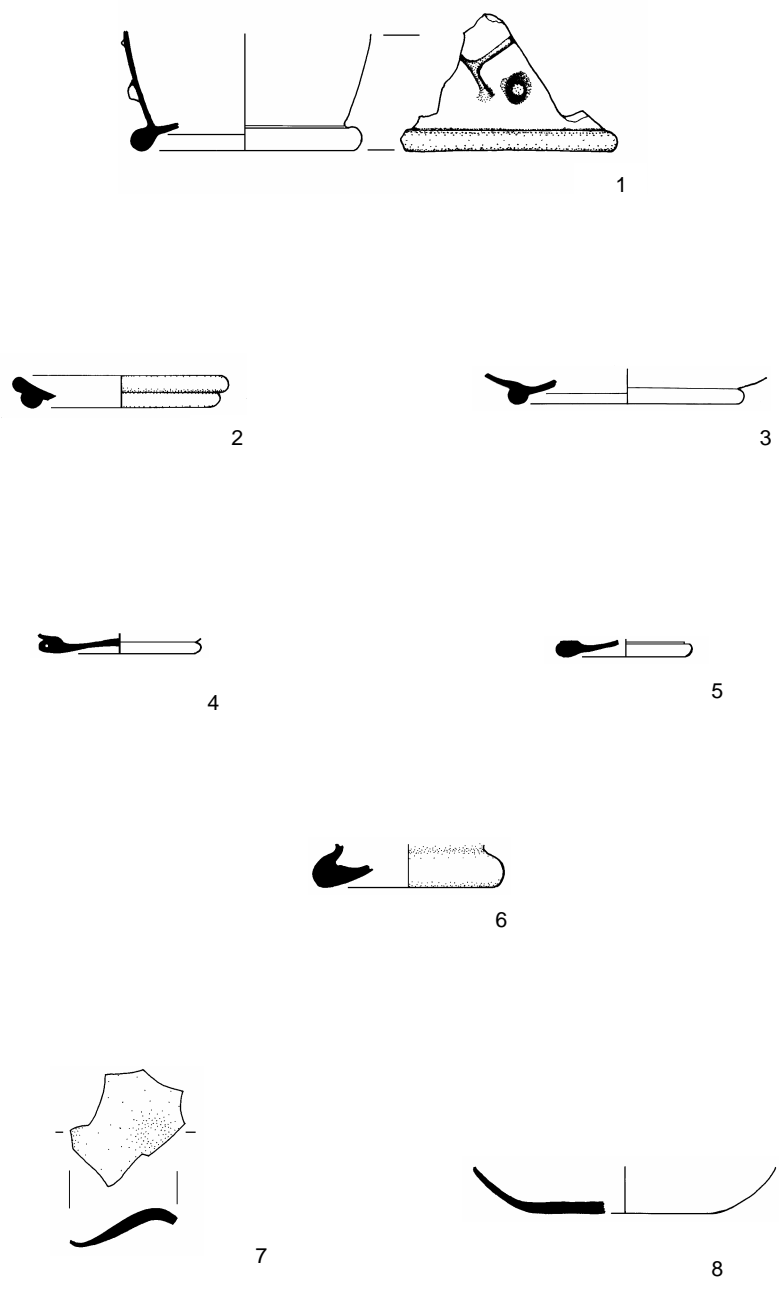

Figure 138 Glass Beaker bases. Scale 1:2

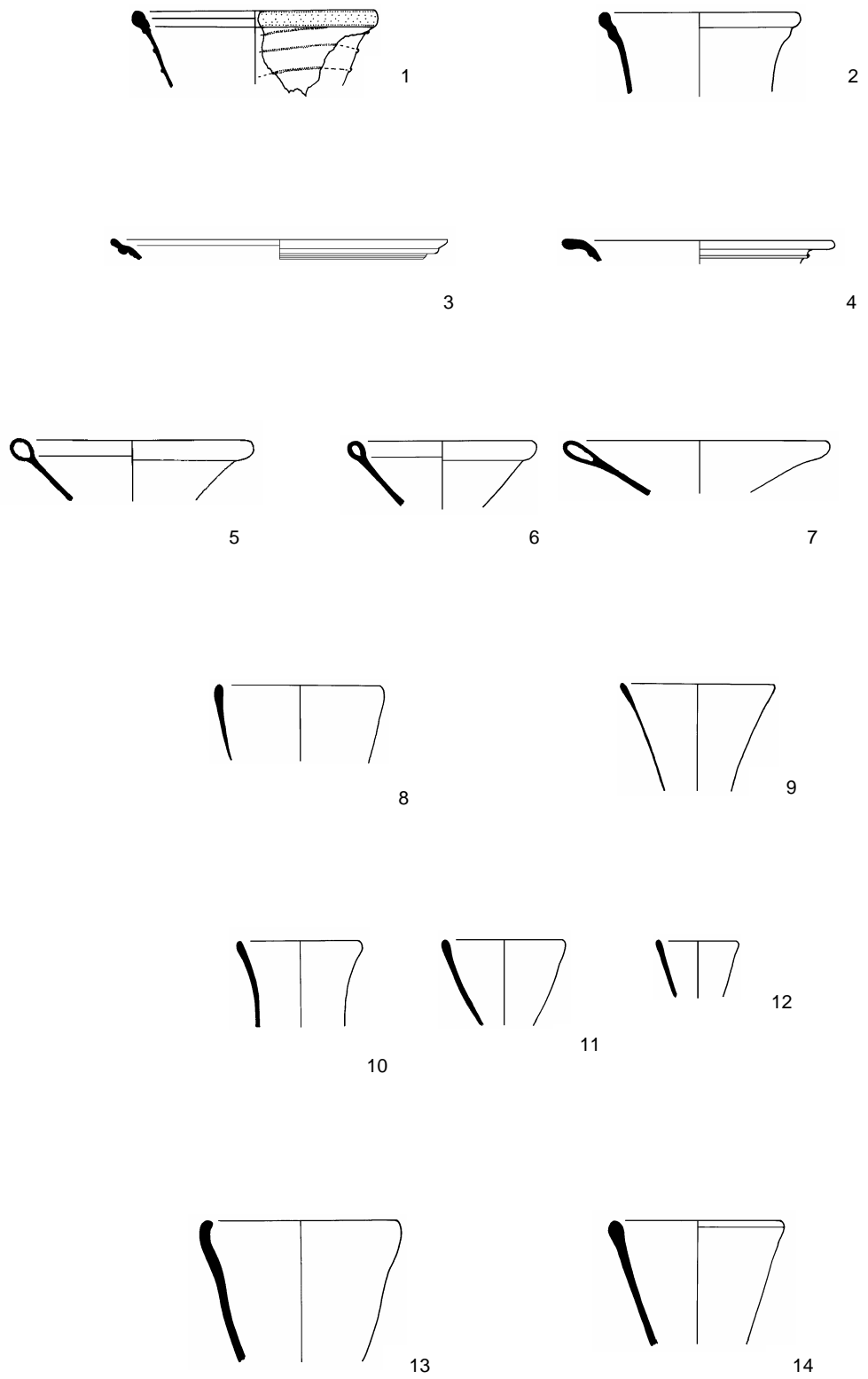

Figure 139 Glass Flasks. Scale 1:2

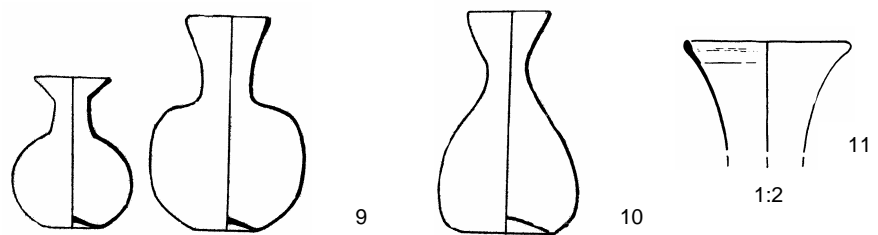
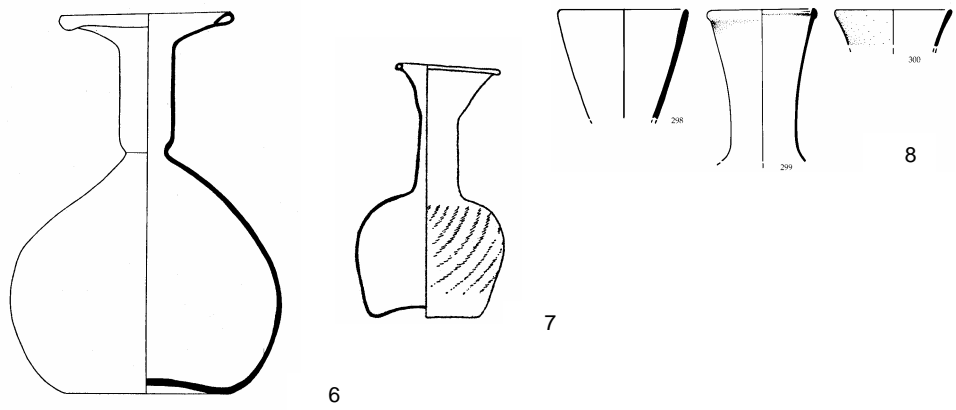
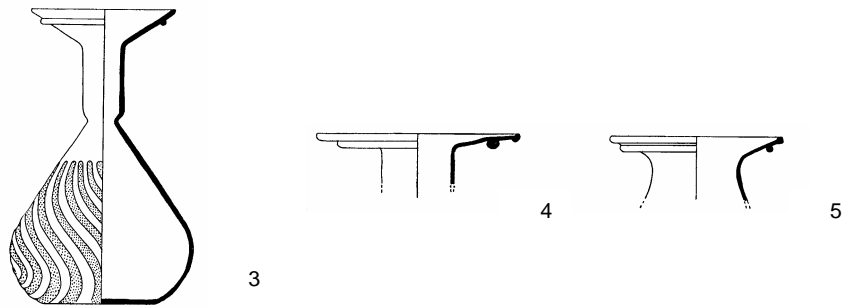
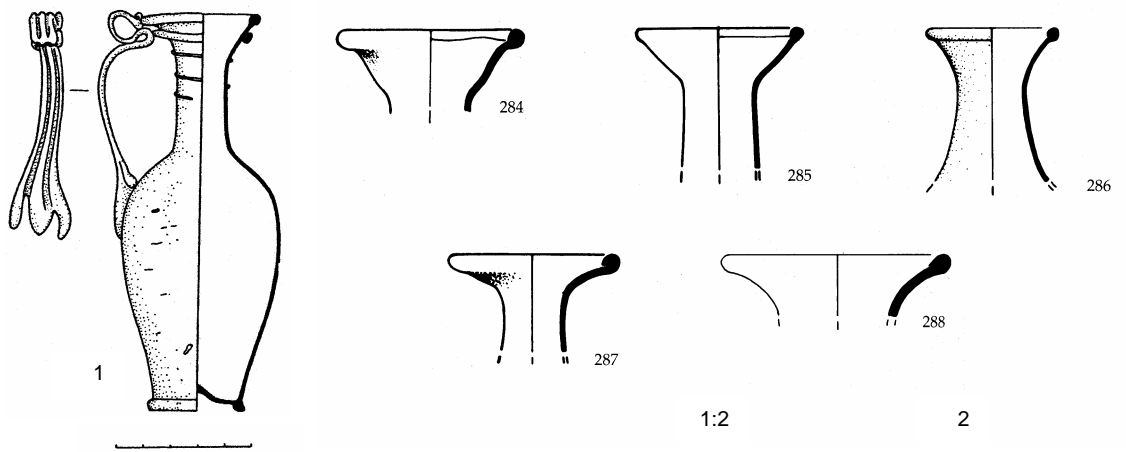

Figure 140 Glass Flasks. Scale 1:4

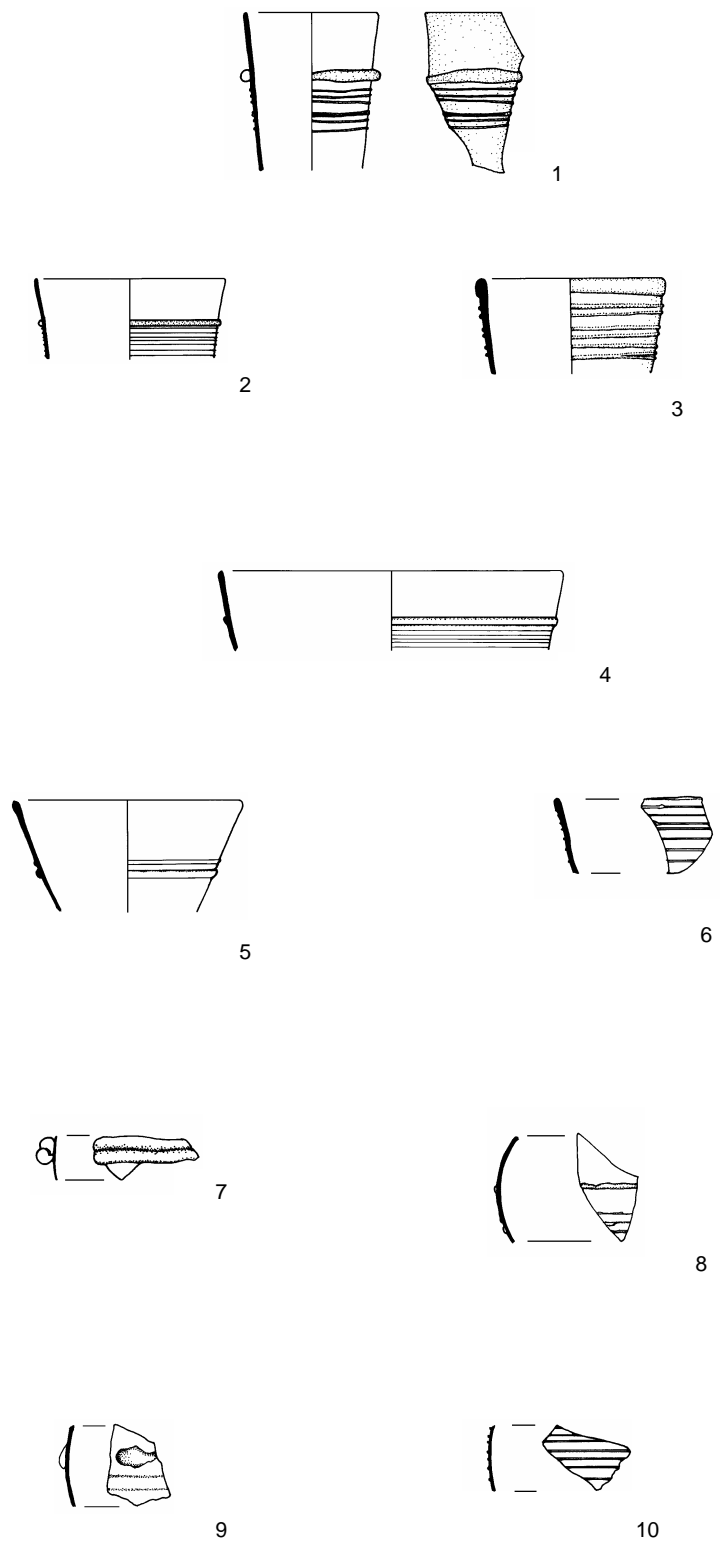

Figure 141 Glass Flasks with spiral trail decoration. Scale 1:2

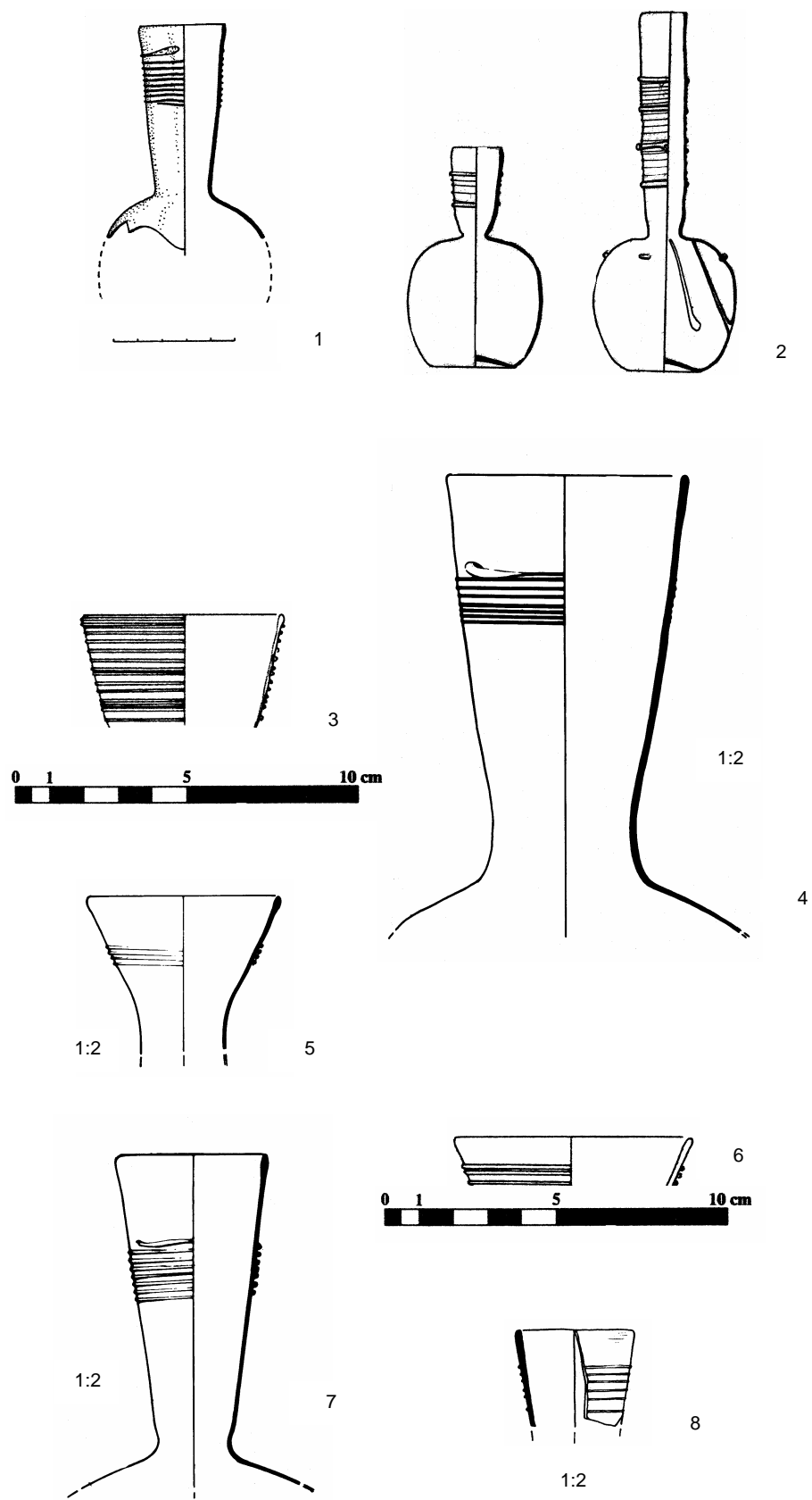

Figure 142 Glass Flasks with spiral trail decoration

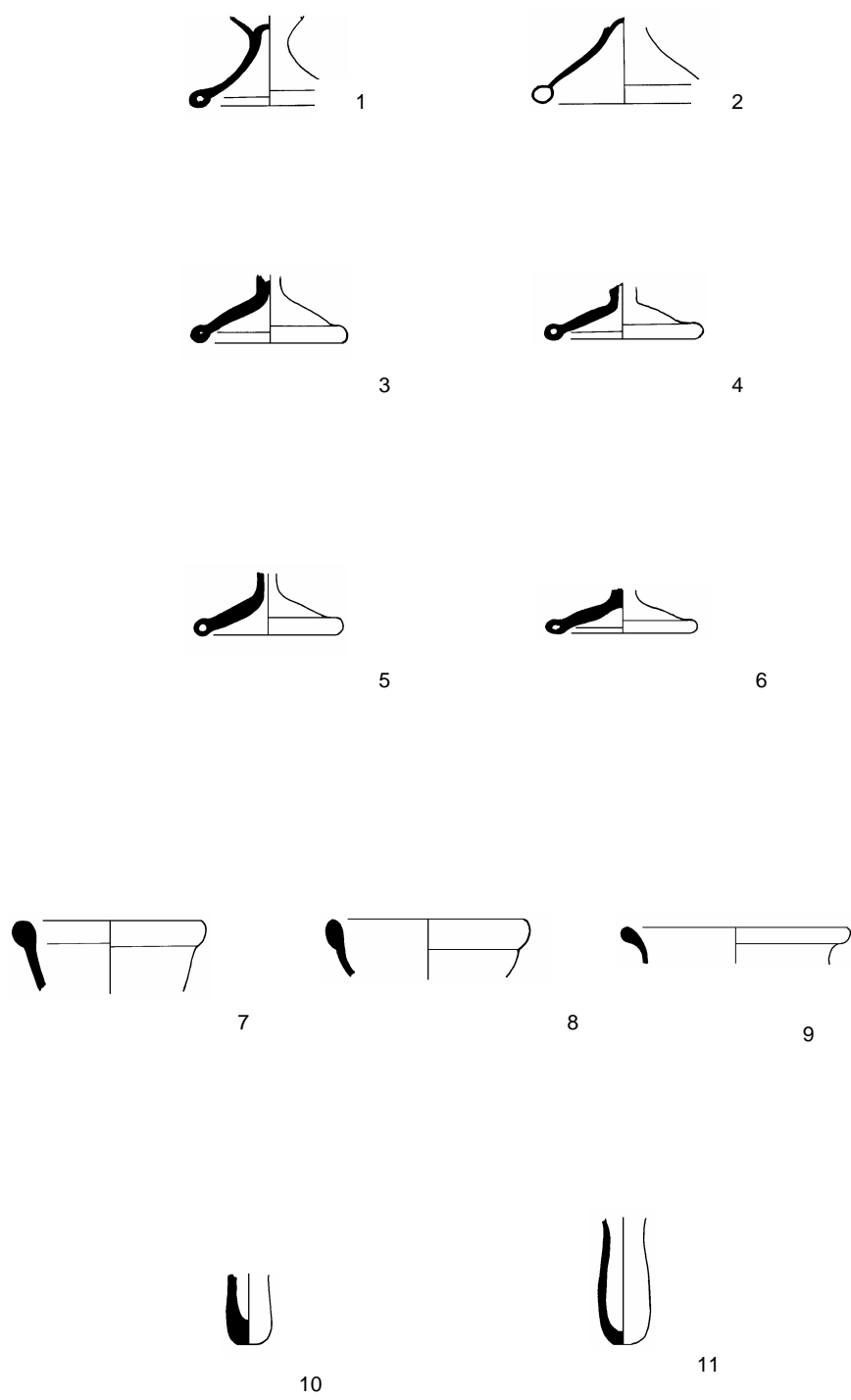

Figure 143 Glass Stemmed Drinking Cups and Bottles. Scale 1:2

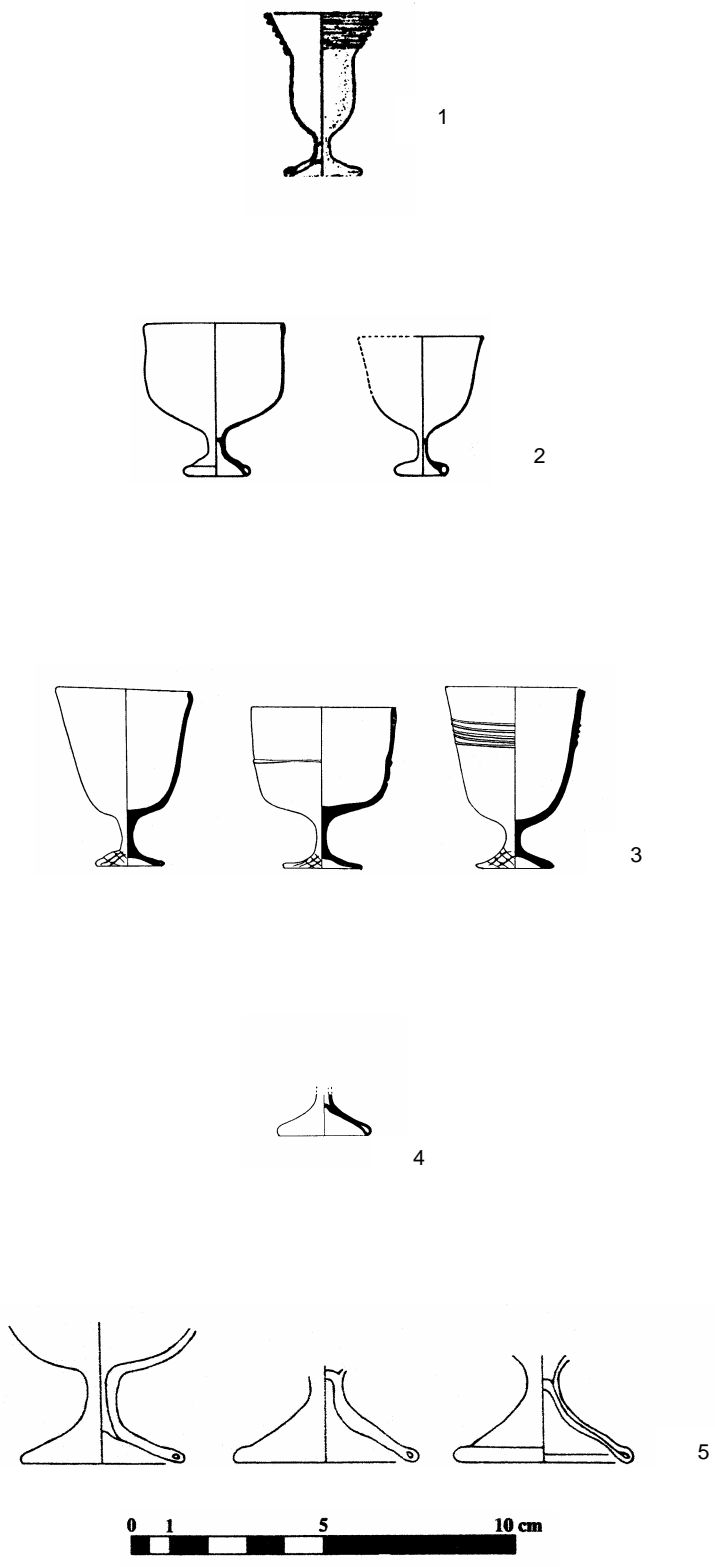
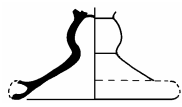
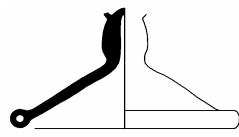

Figure 144 Glass Stemmed Drinking Cups. Scale 1:4



1



2

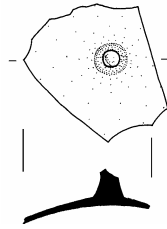

3



4



5



6



7



8



9



10



11

Figure 145 Glass Lids and Unguentarium. Scale 1:2

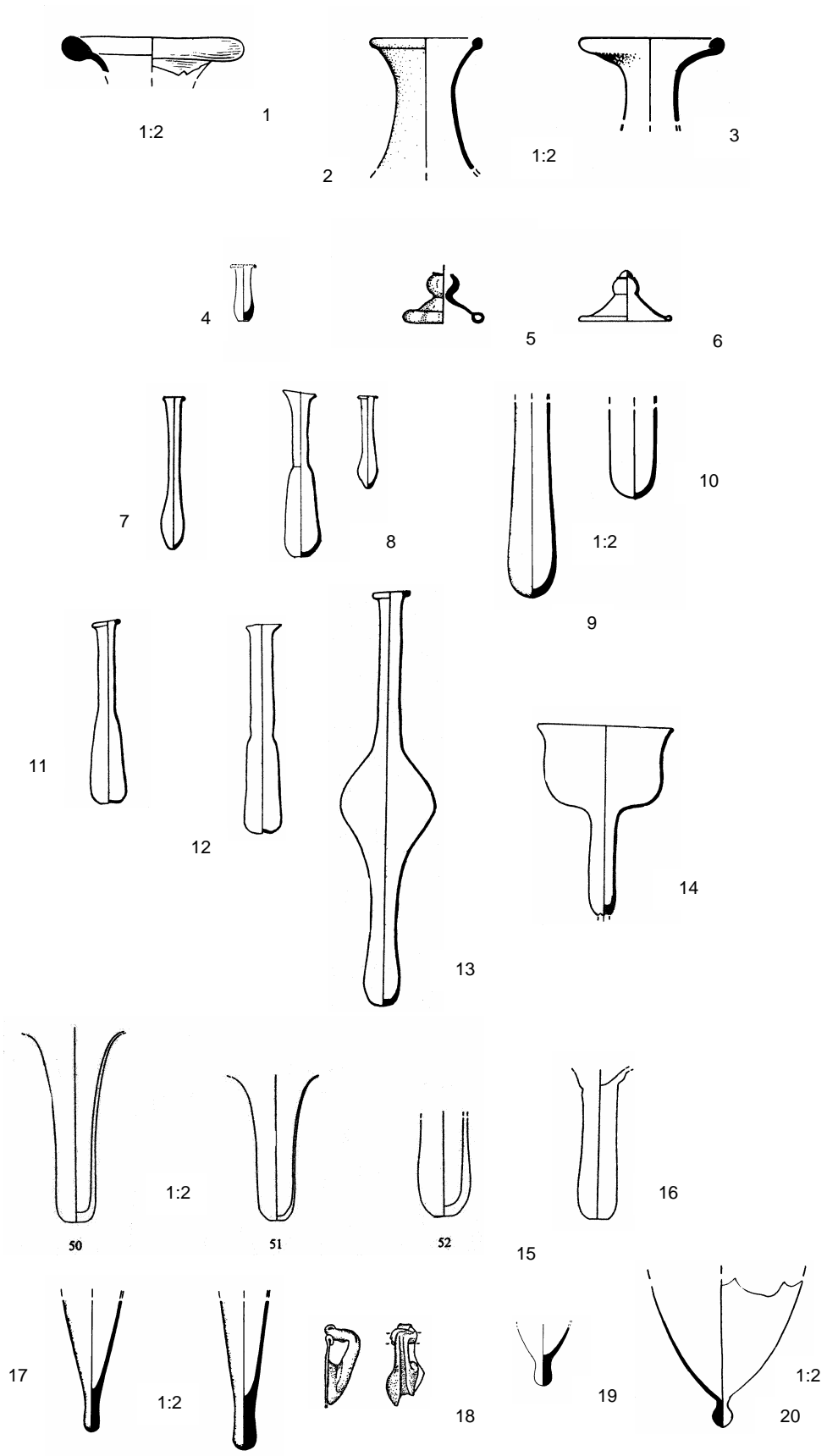

Figure 146 Glass Lids, Unguentarium and Lamps. Scale 1:4

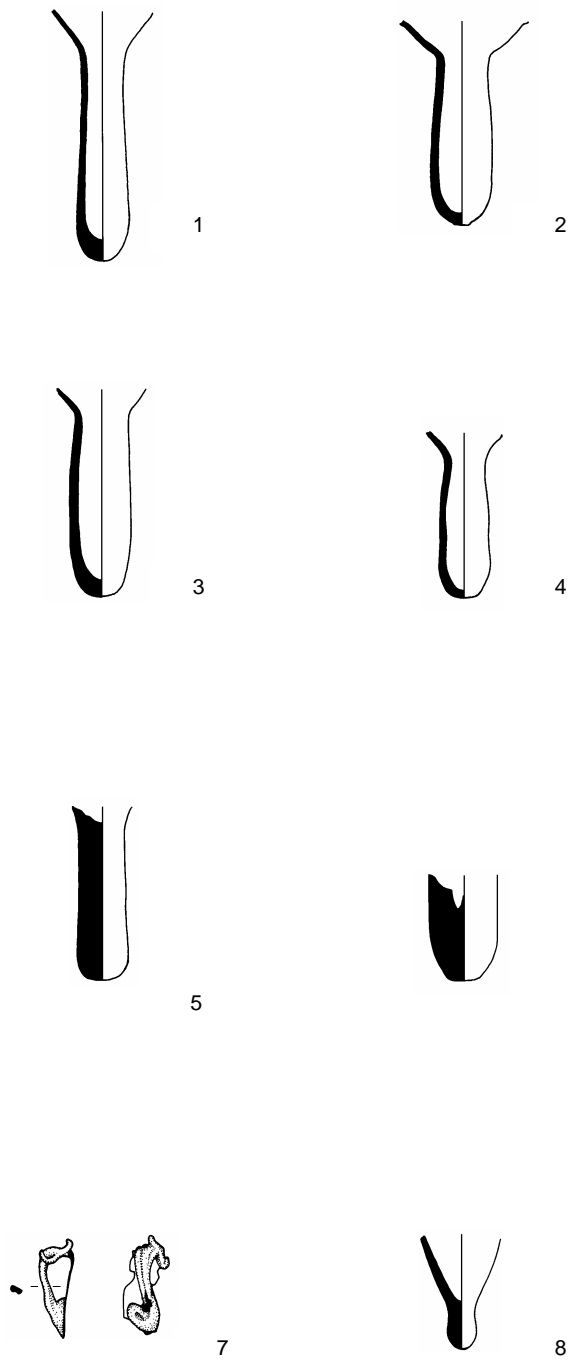

Figure 147 Glass Lamps Scale. 1:2

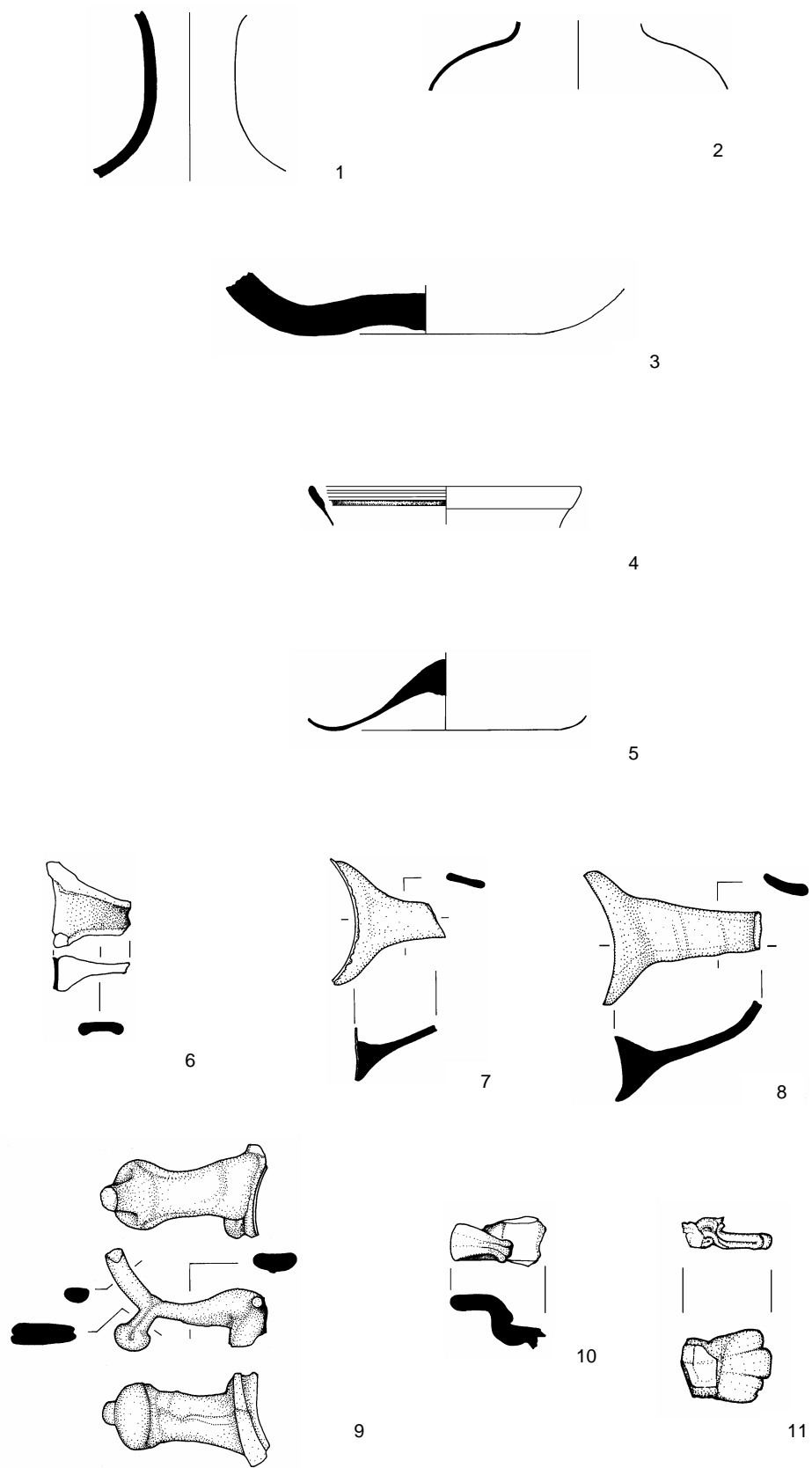

Figure 148 Glass Jugs. Scale 1:2

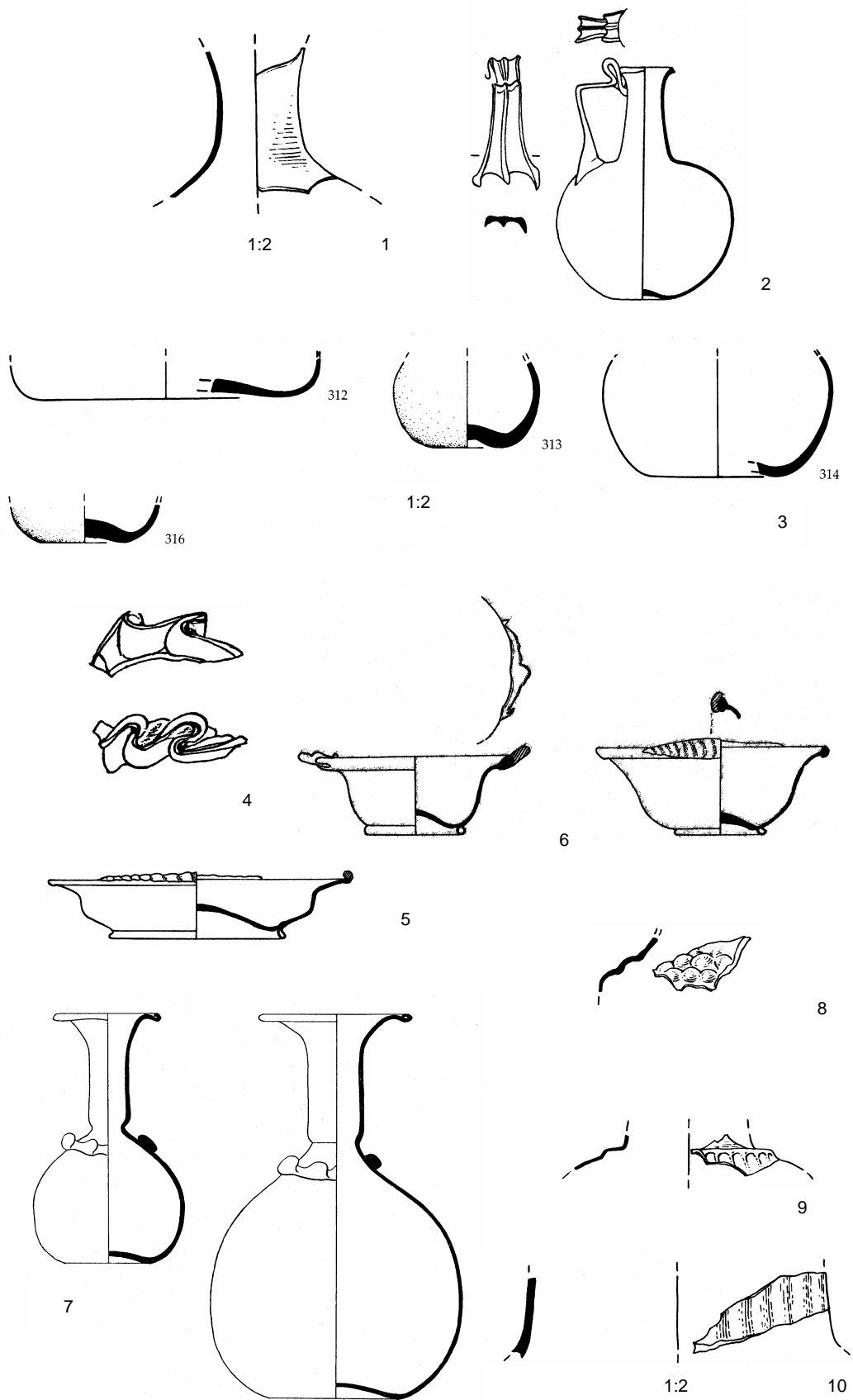

Figure 149 Glass Jugs. Scale 1:4

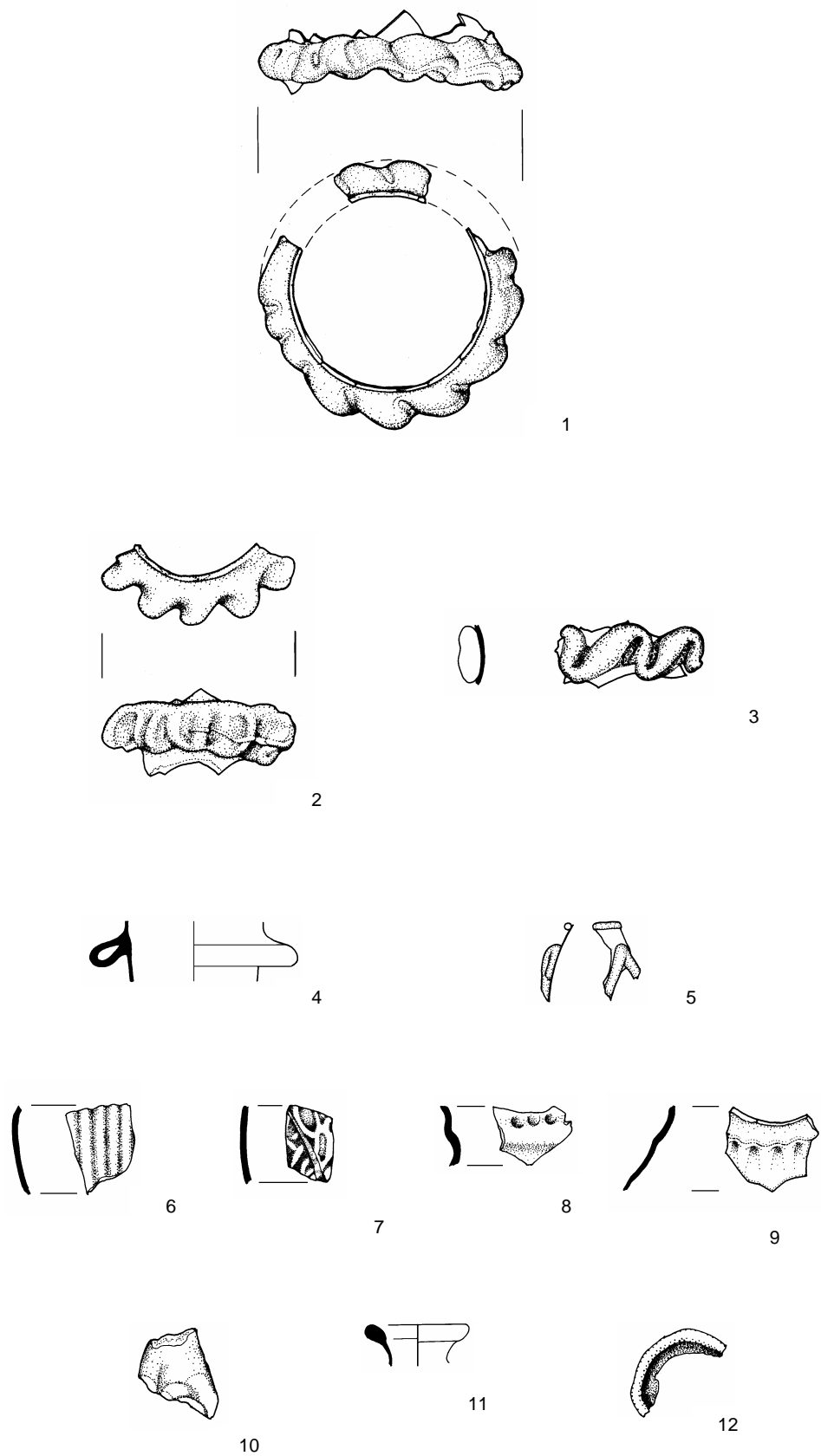

Figure 150 Glass Miscellaneous handles and decoration. Scale 1:2

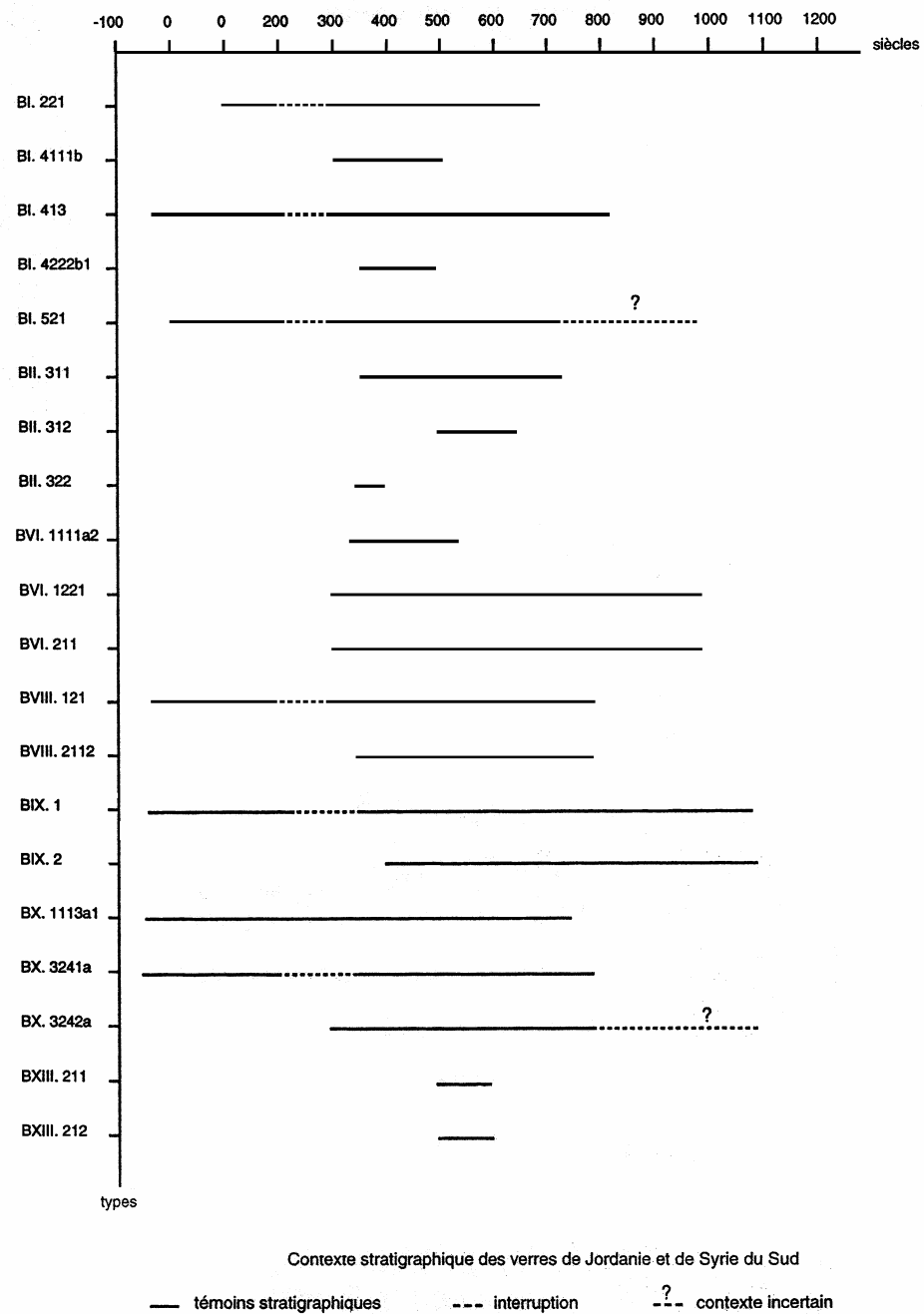

Figure 151 Glass typology and chronology for Jordan and Southern Syria (Source, Dussart, 1995)

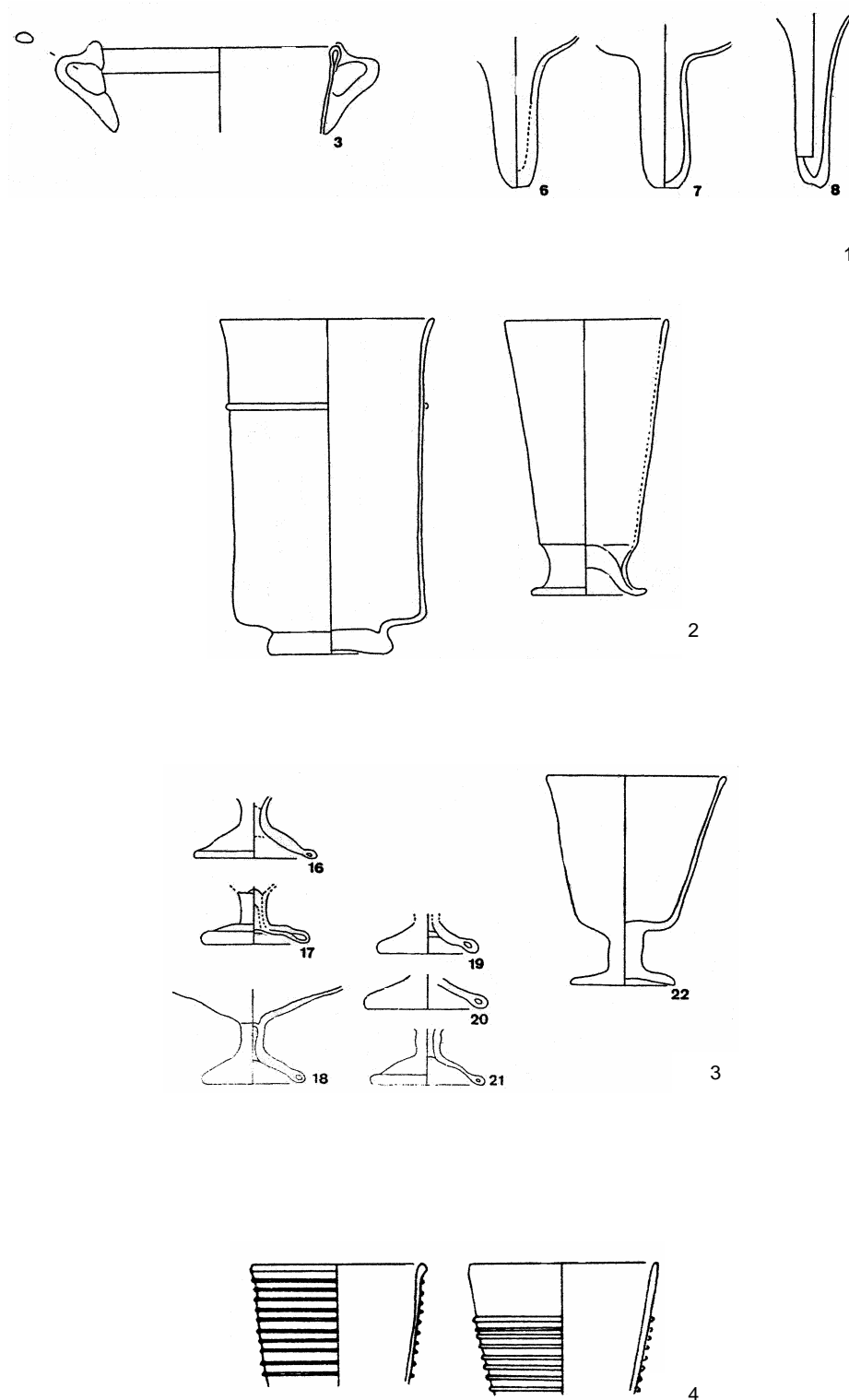

Figure 152 Glass typology for Jordan and Southern Syria (Source, Dussart, 1995)

4. Plates



Plate 1 View of Area Three looking Southeast



Plate 2 Trenches 3A, 3B and 3C



Plate 3 Trench 3A showing paved street with toilet hole to drain, looking south



Plate 4 Early street level? in 3A with covered N/S drain, looking north



Plate 5 **Lowest level in 3A with bedrock and drainage system, looking north**



Plate 6 East Section of trench 3A



Plate 7 South Section of trench 3A



Plate 8 Trench 3B excavated to bedrock, with drainage outlet in south baulk



Plate 9 West Section of trench 3B



Plate 10 Trench 3B showing S/N side drain running into the main E/W drain



Plate 11 **West Section of trench 3C**



Plate 12 **Trench 3C excavated to bedrock, looking south**



Plate 13 Inv.423 (top), Inv.354 (bottom), Inv.808 (right)

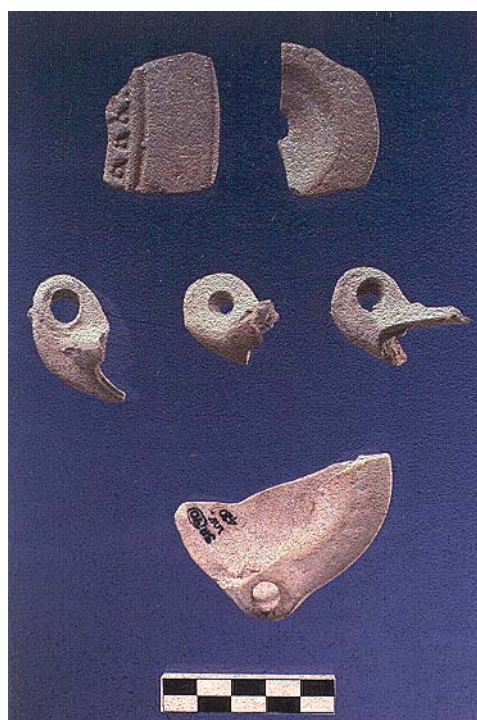

Plate 14 Inv.407 (top left), Inv.7572 (top right), Inv.7581 (centre left),
Inv.7580 (centre), Inv.7542 (centre right), Inv.420 (bottom).



Plate 15 **Inv.500, front**



Plate 16 **Inv.500, back**



Plate 17 Inv.327



Plate 18 Inv.1179 (top), Inv.936 (bottom left), Inv.938 (bottom right)



Plate 19 Inv.279 (top), Inv.302, 303 & 502 (bottom)



Plate 20 **Inv.511 (left), Inv.311 (top right), Inv.512 (bottom right)**

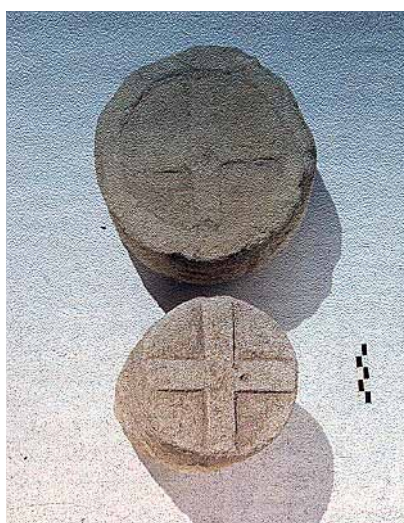

Plate 21 **Inv.495 (top), Inv.494 (bottom)**



Plate 22 Inv.331 (left), Inv.436 (right)



Plate 23 Inv.199 (side view)



Plate 24 **Inv.199 (top view)**



Plate 25 **Glass flasks with spiral trail decoration**



Plate 26 Glass decorative band from flask, Inv.692/704



Plate 27 Glass Lamp bases



Plate 28 Glass Drinking Cup stemmed base, Inv.643 (top), Base for flask, Inv.636 (centre), glass lid, Inv.622 (bottom)



Plate 29 Glass jug base, Inv.696

5. Appendix 1: Inventory Database