

Available online at [www.sciencedirect.com](http://www.sciencedirect.com)**ScienceDirect**

Procedia Engineering 132 (2015) 569 – 576

---

---

**Procedia  
Engineering**

---

---

[www.elsevier.com/locate/procedia](http://www.elsevier.com/locate/procedia)

The Manufacturing Engineering Society International Conference, MESIC 2015

## Machining unidirectional composites using single-point tools: analysis of cutting forces, chip formation and surface integrity

F. Kahwash<sup>a</sup>, I. Shyha<sup>a,\*</sup>, A. Maheri<sup>a</sup><sup>a</sup>*Faculty of Engineering and Environment, Northumbria University Newcastle, Newcastle upon Tyne, NE1 8ST, UK*

---

### Abstract

The need for high quality machining of composite materials is rising due to the increased utilisation of these materials across several applications. This paper presents experimental findings of orthogonal cutting of unidirectional glass fibre reinforced plastic (UD-GFRP) composites using HSS single-point cutting tools. Key process indicators including cutting forces, chip formation and surface integrity were evaluated. Full factorial design is employed with fibre orientation, depth of cut, cutting speed and rake angle as process control variables. Fibre orientation and depth of cut were found to be the most significant factors affecting the investigated responses. Lower cutting forces and better surface quality were obtained at 0° fibre orientation and lower depth of cut. Cutting at 45° fibre orientation generated extremely damaged surfaces with relatively high average surface roughness values and should be avoided in practical applications.

© 2015 The Authors. Published by Elsevier Ltd. This is an open access article under the CC BY-NC-ND license (<http://creativecommons.org/licenses/by-nc-nd/4.0/>).

Peer-review under responsibility of the Scientific Committee of MESIC 2015

*Keywords:* UD-GFRP; Cutting forces; Chip formation; Surface integrity

---

### 1. Introduction

Global market of composites is steadily growing and is expected to reach \$29.9B by 2017 with projected 7% annual growth [1]. The main industries utilising composites are aerospace, construction, transportation and wind energy. Glass-fibre reinforced plastic (GFRP) is widely used due to its high specific stiffness, creep and corrosion resistance [2] as well as its relatively cheap price. For obtaining the final geometry of the composites parts, machining operations such as edge trimming or drilling are often necessary; however, high quality cutting is more

---

\* Corresponding author. Tel.: +44-191-243-7834  
E-mail address: [islam.shyha@northumbria.ac.uk](mailto:islam.shyha@northumbria.ac.uk)

difficult in composites than in metals, due to their inhomogeneous, anisotropic nature and the complicated damage phenomena that occur during cutting. This can result in poor surface finish, dimensional inaccuracies and eventually rejected parts [3].

Orthogonal cutting is widely studied in academic research since it is 2D process and can give insights on the fundamental aspects of the cutting process [3]. Furthermore, the study of unidirectional laminates highlights the effect of composites' anisotropy on the cutting process, which is the most prominent feature distinguishing composites cutting from metal cutting. Orthogonal cutting of composites was studied in [4-7]. These studies were mainly experimental and focused on analysing the chip formation and cutting forces. Analytical and empirical models to predict cutting forces were proposed in [4] and [7] respectively. These studies showed that fibre orientation is a key factor affecting the machinability of the FRPs. Different cutting mechanisms dominate at different fibre orientations, which makes it difficult to develop a general model applicable for all fibre orientations [8]; for example, the analytical model developed in [4] for cutting forces was limited to fibre orientations between  $90^\circ$  and  $180^\circ$ . Experimentally, it was found by Wang et al. [5] that at  $0^\circ$  orientation, the main cutting force decreased with increased rake angle, whereas at positive orientations, increased rake angle caused increase in the thrust force. The optimum rake angle that would minimise the principle cutting force was found to be  $30^\circ$  [3]. Several publications studied the effect of depth of cut on the cutting forces, e.g. [5, 7, 9, 10], however, these studies investigated small range of values between 0.08mm and 0.381mm. It was found that the depth of cut causes increase in the cutting force following a linear pattern. Chip formation in  $0^\circ$  orientation and  $0^\circ$  rake angle results from intensive compression stresses at the tool-workpiece interface producing brooming failure that propagates parallel to fibre direction, while chip formation at  $0^\circ$  orientation and positive rake angles is mainly governed by mode I failure that propagates ahead of the cutting edge [3, 5]. For orientations  $\geq 90^\circ$ , macro fracture, inter-laminar shear and out of plane displacement were the main mechanisms [5, 6]. Quality of machined surface was closely related to the cutting mechanisms, which in turn was affected by fibre orientation. The best surface quality was obtained in the orientation range between  $15^\circ$  and  $60^\circ$  while at  $0^\circ$  roughness was marginally higher. Severe surface damage was observed beyond  $60^\circ$  [5]. Palanikumar [11] studied surface roughness when turning GFRP and found that it increases with increased fibre orientation and feed rate while it decreases with increased cutting speed and depth of cut.

Despite these efforts, several issues require further investigation, for example, it was recommended in [3] that the effect of depth of cut on cutting forces needs more research. The authors believe that this should include choosing more aggressive values in experiments since using bigger depth is advantageous in terms of increasing material removal rates and hence speeding up cutting process. In addition, to the authors' best knowledge; limited attempts were previously made to quantify the statistical significance of the studied variables. As such the objective of this paper is to quantify the statistical significance of fibre orientation, rake angle, depth of cut and cutting speed on the cutting forces, chip formation and surface integrity. Furthermore, the results from this study will be used to construct/validate machining model for unidirectional composites which is currently being developed utilising mesh-free method (Element Free Galerkin).

## 2. Experimental Work

Unidirectional samples of GFRP were used in this investigation as workpiece materials. The relevant sample data are shown in Table 1. Single-point high speed steel cutting tools with dimensions of  $1/4'' \times 1/4'' \times 2 \ 1/2''$  and having  $0^\circ$ ,  $5^\circ$  and  $10^\circ$  rake angles and  $14^\circ$  clearance angle were used. New tool was used for every test in order to eliminate the effect of tool wear on the studied responses.

Table 1: Properties of UD-GFRP workpiece

Property	Value
Fibre type	E Glass
Matrix type	Bisphenol-A-(Epichlorhydrin) epoxy resin
Fibre volume fraction	~70%
Fibre orientation	94% at $0^\circ$ / 6% at $90^\circ$

Dimensions	80 x 80 x 2.1mm
Number/thickness of lamina	5 / 0.42mm

The process variables included rake angle, cutting speed, fibre orientation and depth of cut all were tested at three levels except cutting speed which was tested at two levels as shown in Table 2. The output responses were cutting forces (cutting and thrust force), chip morphology and surface integrity. Fig.1 shows a schematic of the experimental set up. Experiments were performed using Royal 10” shaping machine. Cutting forces were measured using Kistler 9257B tri-axial dynamometer, which was mounted on the table of the shaping machine. The dynamometer was connected to data acquisition system and channel amplifier. The cutting forces data was displayed using Dynaware software version 2.6.4.15. The workpieces were clamped in vertical position so that the fibre orientation effect can be investigated as shown in Fig. 2. High speed video was taken using Hotshot CC1024 connected to PC with Hotshot link software to operate and process the captured videos. The camera was equipped with Sigma Macro 105mm F2.8 EX-DG lens that has high optical performance up to 1:1 magnification, which enabled detailed view of the action at the cutting edge. Videos were taken at 700 and 1000 frames per second. Four sources of LED lights were used to provide proper illumination. Each cutting test had a length of 80mm. 3D surface topography assessment was carried out using an Alicona Infinite Focus G4 optical scanner, having a resolution down to 10nm. The scanning area was 3.9mm x 2.1mm in axial and circumferential directions respectively. Scans were obtained using 2.4µm and 7.8µm vertical (Z direction) and lateral (X and Y) resolutions respectively. Average surface roughness was then measured from the 3D scans in the cutting direction in accordance in with Fig. 4. All measurements conformed to ISO4287 using 0.8mm cut-off and 4mm evaluation length. The roughness measurements were taken at three locations in the machined surface, one at the centre and two at 0.5mm distance from the start and end edges and average was then computed. Chip morphology was also assessed using a stereoscope (Leica EZ4D) in conjunction with Leica LAS EZ software. Fibre orientation is measured along the cutting plane in clockwise direction. This is different from some previous literature which measured the angle in counter clock wise direction. Therefore, the 45° orientation here can be mapped to 135° in previous literature. The fibre orientation convention is shown in Fig.3.

Table 2: Process variables and their levels

Variables	Levels		
Rake angle (o)	0	5	10
Cutting speed (m/min)	14	19	-
Fibre orientation (o)	0	45	90
Depth of cut (mm)	0.25	0.5	1

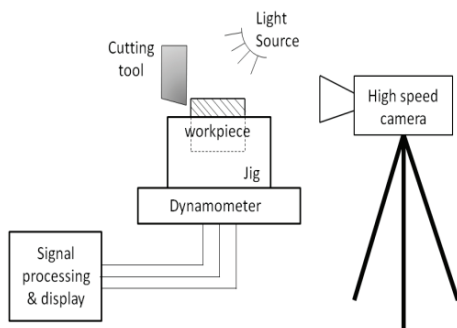

Fig.1. Schematic of experimental set up

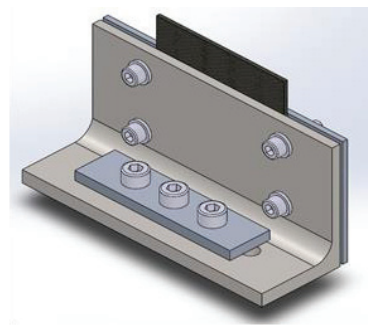

Fig. 2. Bespoke fixture design for clamping the GFRP sample

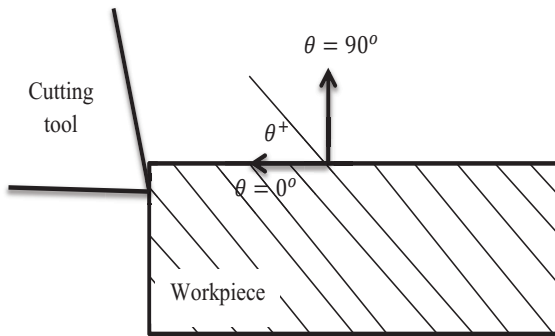

Fig.3. Fibre Orientation convention

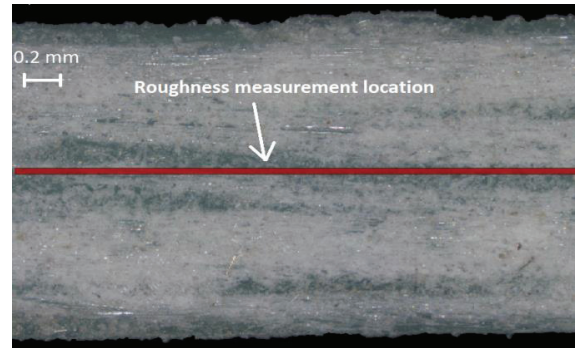

Fig. 4. Location of roughness measurements

### 3. Results and discussion

Fig. 5 shows sample cutting force measurement for three different fibre orientations. Larger fluctuation in force signal was observed when cutting samples having 90o fibre orientation, see Fig. 5(c). This was probably caused by the tool cutting through layers of fibres and matrix in sequence across the depth of cut. The peak noticed at the beginning of Fig. 5(a) is most likely due to the initial impact of the cutting tool on the workpiece. In general, the main cutting force ranged between 90N and 637N and with overall average of 381N.

Fig. 6 shows the main effects plot for the cutting force. Average cutting force measured when cutting workpieces had 45o and 90o fibre orientations differed significantly from 0o fibre orientation. Lower cutting forces were obtained when cutting using 0o rake angle, lower cutting speed, 0o fibre orientation and low depth of cut. Clearly, fibre orientation and depth of cut were found to have substantial influence on cutting force. Contrary to previous literature [7, 9], average cutting force was found to increase with the rake angle. This may be attributed to the different test conditions used in this work. For example in [7], the cutting speed was kept at 0.46m/min, depth of cut up to 0.25mm, the rake angle was between 0o and 30o and the fibre volume fraction (FVF) was 42%; whereas in this study, speed up to 19m/min, 1mm depth of cut, 0o to 10o rake angles and 70% FVF were used. Rake angle and cutting speed had lower contribution on the cutting force results. Table 3 shows the ANOVA results for the main cutting force. Although all factors were found statistically significant at the 5% level but the depth of cut had the highest PCR for 48% followed by fibre orientation with ~30% PCR. The error associated with the main cutting force evaluation was marginally higher than the accepted level (15%) which could be ascribed to possible unconsidered interactions between some of the control factors.

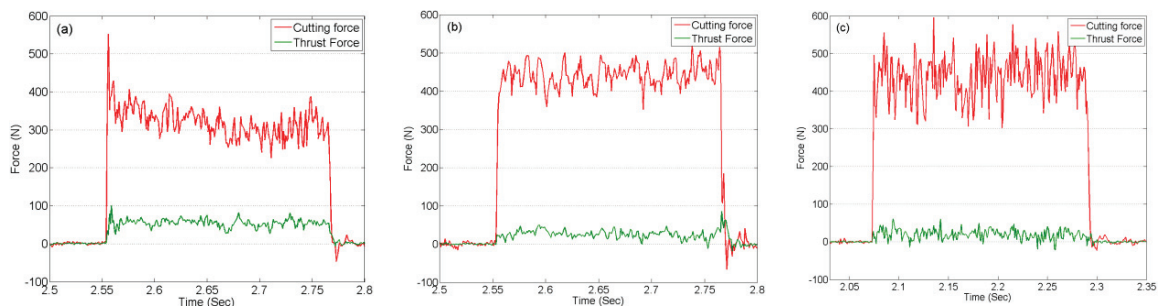

Fig. 5. Sample cutting forces at 5° rake angle and 19 m/min cutting speed, 0.5 mm depth of cut and various fibre orientations (a) 0°, (b) 45° and (c) 90°

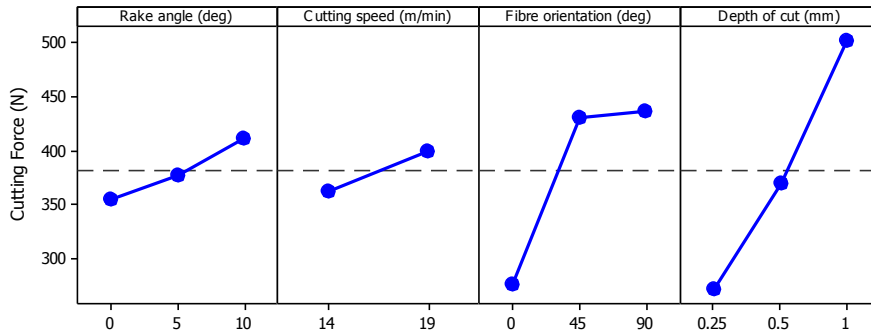

Fig. 6. Main effects plot for cutting forces

Table 3: ANOVA results for main cutting forces

Source	DF	SS	MSS	SSe	F	P	PCR
Rake angle	2	29203	14601	25731	4.21	0.021*	2.63
Cutting speed	1	19331	19331	15859	5.57	0.023*	1.62
Fibre orientation	2	296835	148418	293363	42.75	0*	29.95
Depth of cut	2	474517	237259	471045	68.34	0*	48.09
Error	46	159689	3472	-	-	-	17.72
Total	53	979575					

\* Significant at the 5% level

DF = Degrees of freedom

F = F-test value

SS = Sum of squares

P = Probability (-)

MMS = Mean sum of squares

PCR = Percent contribution ratio

SSe = Expected sum of squares

The average thrust force for the tests performed was ~30N, which is ~11% of the average main cutting force. It can be seen from the main effects plot in Fig. 7 that the rake angle and the fibre orientation are the most significant factors affecting the thrust force. Thrust force decreased with increased rake angle. This is in agreement with the findings reported in [7] but differs from the conclusions drawn in [5]. Cutting speed and depth of cut had negligible effect. Lower thrust force has been obtained with increased rake angles and when cutting 90o fibre orientation samples. Table 4 shows the ANOVA results for the thrust force. Rake angle and fibre orientation were found to be statistically significant at the 5% level with a relatively higher PCR of 48% and 38% respectively. The small error level (13%) associated with the thrust force evaluation was within the acceptable levels (up to 15%), suggesting that all important variables had been considered and measurements accurately performed.

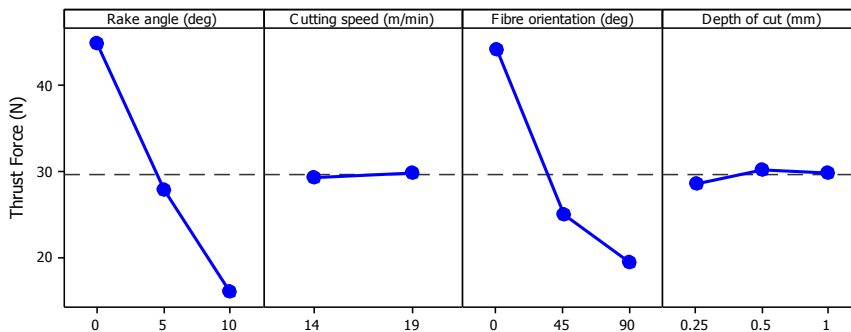

Fig. 7. Main effects plot for thrust force

Table 4: ANOVA results for thrust force

Source	DF	SS	MSS	SSe	F	P	PCR
Rake angle	2	7619.7	3809.85	7576.893	89	0*	48.26
Cutting speed	1	2.9	2.9	0	0.07	0.794	0.00
Fibre orientation	2	6085.4	3042.7	6042.593	71.08	0*	38.48
Depth of cut	2	24.2	12.1	0	0.28	0.755	0.00
Error	46	1969.1	42.80652	-	-	-	13.26
Total	53	15701.2					

\* Significant at the 5% level

High speed videos showed strong dependency of the chip formation on the fibre orientation. This is evident in Fig. 8, which shows distinct chip formations at  $0^\circ$ ,  $45^\circ$  and  $90^\circ$  angles. At  $0^\circ$  fibre orientation, long and continuous chips were observed with crushed area ahead of the cutting tool. Cutting  $45^\circ$  samples resulted in fragmented chips flowing on the rake face. Sustainable cutting took place mainly in the centre of the workpiece while workpiece sides (fibre/matrix) deflected under the tool cutting edge and bounced back once the tool has advanced. This is evident by the recorded high speed videos which clearly showed that the side fibres/matrix were subjected to bending, buckling and out of plane forces. In other words, the fibres along the unsupported edges (sides) were deflected outwards under the tool nose and bounced back after tool progression, which resulted in valley-shaped cuts across the width of the workpiece; as shown in Fig. 9(b).  $90^\circ$  orientation resulted in small and dust-like chips ejected at high speeds. Material failure was governed by shear due to bending exerted by the tool on the workpiece. Fibre bouncing and pull out along the unsupported edges was also observed leading to high subsurface damage and edge delamination although to less extent than the  $45^\circ$  cuts.

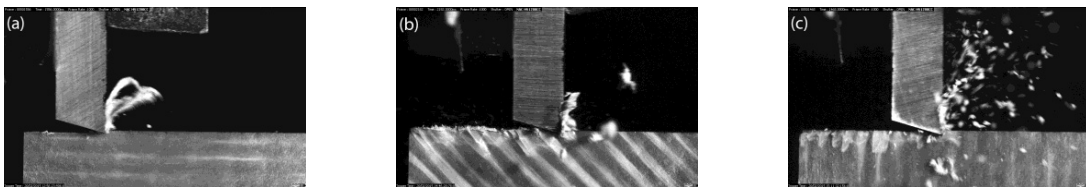
Fig. 8. Sample chip formation at (a)  $0^\circ$ , (b)  $45^\circ$  and (c)  $90^\circ$  orientation

Depth of cut affected the chip formation in all three cases. In  $45^\circ$  and  $90^\circ$  a substantial subsurface damage was observed accompanied with uncut material on the unsupported edges. The extent of the damage correlated to the depth of cut, i.e. higher damage with increased depth of cut. Rake angle had little effect on chip formation, which agrees with the findings in [5, 12]. Also cutting speed had a minimum effect on the chip formation. This might be due to the relatively small range of cutting speed levels. The longitudinal roughness calculations were taken at the centre of the workpiece because of the severe damage at the edges caused by out-of-plane deformation of the fibres in  $45^\circ$  and  $90^\circ$  samples as shown in Fig. 9(b),(c). Generally,  $0^\circ$  cuts generated the best transverse profile as seen in Fig. 9(a) and the cleanest surfaces with overall average of  $3.9\mu\text{m}$  as compared with  $21.9\mu\text{m}$  and  $5.5\mu\text{m}$  for  $45^\circ$  and  $90^\circ$  respectively. In Fig. 9(b) fibre pull-out is evident on the unsupported sides with a V-shaped transverse profile. Fig. 9(c) shows uncut fibres as well but with 'U' transverse shape.

Fig. 9. Sample surface map at 0 rake, 19 m/min, 0.25 mm depth and (a)  $0^\circ$ , (b)  $45^\circ$  and (c)  $90^\circ$

Table 5: Ra statistics as a function of fibre orientation

Fibre orientation	Ra(μm)		
	Mean	Min	Max
0°	3.9	2.3	6.1
45°	21.9	11	56.9
90°	5.5	3.1	15.6

Table 5 shows the basic results of the average surface roughness (Ra) as a function of the fibre orientation. The 0° results are comparable to previous literature e.g. average Ra of 2μm to 3μm was reported in [5] whereas roughness measurements beyond 60° were not reported due to the severe surface damage. This includes the 45° and 90°, since the 45° in this study is equivalent to 135° in [5]. Palanikumar [11] investigated the surface roughness while turning GFRP, although 0° orientation was not investigated, it was noted that increased fibre orientation caused increase in roughness. While their findings cannot be mapped directly to this study, it shows the general trend in both studies is similar. Fig. 10 and Table 6 show the main effects plot and ANOVA results for Ra. Fibre orientation and depth of cut were the statistically significant factors at the 5% level. The fibre orientation contribution was found to be dominant with ~4 times increase in roughness at 45° as compared to 0° and 90° fibre orientations. Increased depth of cut also resulted in rise in the average roughness. Cutting speed and rake angle had lower effects on Ra. ANOVA results (Table 6) showed that only fibre orientation and depth of cut were found statistically significant affecting the average surface roughness with a corresponding PCR of 53% and 9% respectively. For fibre orientation, these results were in agreement with the visual observations where poor surface quality was produced from cutting 45° fibre orientation laminates.

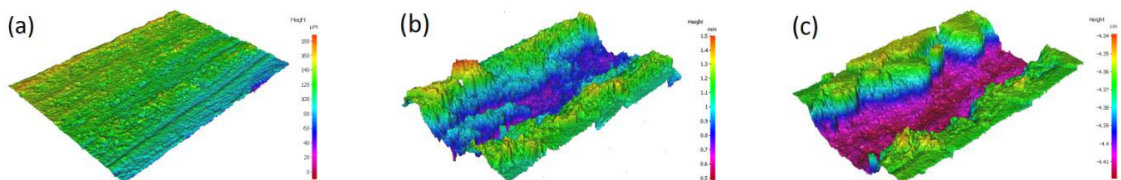
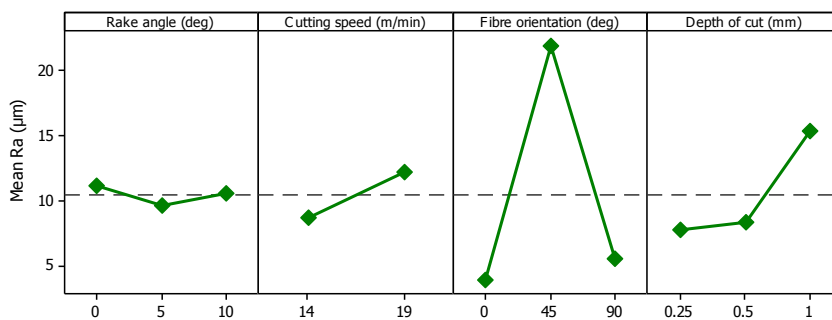

Fig. 10. Main effects plot for Ra

Table 6: ANOVA results for Ra

Source	DF	SS	MSS	SSe	F	P	PCR
Rake angle	2	23.78	11.89	0	0.24	0.787	0.00
Cutting speed	1	158.48	158.48	109.06	3.21	0.08	1.64
Fibre orientation	2	3577.41	1788.7	3527.99	36.19	0*	52.90
Depth of cut	2	636.07	318.03	586.65	6.43	0.003*	8.80
Error	46	2273.51	49.42	-	-	-	36.67
Total	53	6669.25					

\* Significant at the 5% level

The average waviness of the surface (Wa) showed similar trends to Ra, with the fibre orientation as the dominant factor followed by the depth of cut while rake angle and cutting speed were found to have limited impact on average surface waviness. The overall average of the waviness was 28.5μm and it varied from 3.2μm to 183.9μm.

#### 4. Conclusions

This paper summarised the results of experimental work on the cutting of UD-GFRP. The cutting forces, chip formation and surface integrity showed a strong dependency on the fibre orientation. The principle cutting force was mainly dependent on fibre orientation and depth of cut and averaged 381.3N, whereas the thrust force was mainly affected by the fibre orientation and the rake angle and had mean ~30N. Three distinct chip sizes were observed for the three levels of fibre orientation. Long continuous chips resulted at the 0°, segmented chips at 45° and dust like particles at the 90°. These different sizes reflect different cutting mechanisms. Average roughness (10.5µm) and waviness (28.5µm) of the machined surface was affected mainly by the fibre orientation and depth of cut. Out-of-plane deformation of unsupported fibres at the edges caused large damaged surface at 45° and 90° orientations with substantially higher roughness at 45°. By choosing wide range of depth of cut up to 1mm, it was found that it is statistically more significant than fibre orientation, which was thought of previously as the most influential factor affecting the main cutting force. To summaries, cutting at 0° and small depth of cut resulted in better surface quality and lower cutting forces. Rake angle and cutting speed were found to be less significant factors. Cutting at 45° should be avoided in practical applications and cutting of unsupported edges is also undesirable since it generates out-of-plane fibre deformation and subsequently lower surface quality. These experimental results will be used to validate numerical machining model of composites, which is part of the authors' ongoing research. Further work is planned to critically investigate the influence of fibre volume fraction and fibre orientation when single point cutting of fibre reinforced plastic composites.

#### 5. Acknowledgement

The authors are grateful to FYP students at Northumbria University Abdulhai Mashhour, Andrew Bainbridge and Isaac Atkinson for their contribution in the experiments. The authors would also like to thank the department of mechanical and construction engineering at Northumbria University for technical support to carry out this research.

#### References

- [1] C. Kazmierski, Growth opportunities in global composites industry 2012-2017, Lucintel 2012.
- [2] K. Palanikumar, Analyzing surface quality in machined composites, in: H. Hocheng (Ed.), *Machining Technology for Composite Materials*, Woodhead Publishing, 2012, pp. 154-182.
- [3] G. Caprino, A. Langella, Analysing cutting forces in machining processes for polymer-based composites, in: H. Hocheng (Ed.), *Machining Technology for Composite Materials*, Woodhead Publishing, 2012, pp. 75-115.
- [4] N. Bhatnagar, N. Ramakrishnan, N. K. Naik, R. Komanduri, On the machining of fiber reinforced plastic (FRP) composite laminates, *Int. J. of Machine Tools and Manufacture* 35 (1995) 701-716.
- [5] D. H. Wang, M. Ramulu, D. Arola, Orthogonal cutting mechanisms of graphite/epoxy composite. Part I: unidirectional laminate, *Int. J. of Machine Tools and Manufacture* 35 (1995) 1623-1638.
- [6] D. Arola, M. Ramulu, D. H. Wang, Chip formation in orthogonal trimming of graphite/epoxy composite, *Composites Part A: App. Sci. and Manufacturing* 27 (1996) 121-133.
- [7] G. Caprino, L. Nele, Cutting forces in orthogonal cutting of unidirectional GFRP composites, *J. Eng. Materials and Tech.* 118 (1996) 419-425.
- [8] S. Gordon, M. Hillery, A review of the cutting of composite materials, *Proc. Inst. of Mech. Eng. Part L: J. Materials Design and Applications* 217 (2003) 35-45.
- [9] D. Nayak, N. Bhatnagar, P. Mahajan, Machining studies of uni-directional glass fiber reinforced plastic (UD-GFRP) composites part I: effect of geometrical and process parameters, *Machining Sci. Tech.* 9 (2005) 481-501.
- [10] G. V. G. Rao, P. Mahajan, N. Bhatnagar, Micro-mechanical modeling of machining of FRP composites – Cutting force analysis, *Composites Sci. Tech.* 67 (2007) 579-593.
- [11] K. Palanikumar, Modeling and analysis for surface roughness in machining glass fibre reinforced plastics using response surface methodology, *Materials & Design* 28 (2007) 2611-2618.
- [12] G. V. G. Rao, P. Mahajan, N. Bhatnagar, Three-dimensional macro-mechanical finite element model for machining of unidirectional-fiber reinforced polymer composites, *Materials Sci. Eng.: A* 498 (2008) 142-149.