

P. A. KROPACHEV, A. D. MEKHTIYEV, F. N. BULATBAYEV,
Y. ZH. SARSIKEYEV, A. V. YURCHENKO

ISSN 0543-5846
METABK 60(3-4) 343-346 (2021)

UDC – UDK 669.13: 621 – 233: 621.4: 518.1: 620.16 – 539.381 = 111

METHOD OF RESTORING PIVOT CONNECTIONS CAST IRON BUSHINGS OF HEAT ENGINE WITH EXTERNAL HEAT SUPPLY

Received – Priljeno: 2020-11-21

Accepted – Prihvačeno: 2021-03-10

Preliminary Note – Prethodno priopćenje

The article presents the results of studies aimed at developing a method of restoring cast iron bushings for pivot connections of a heat engine with external heat supply. The methods of computer modeling the stress-strain state of the pivot connections are used. To carry out computer modeling, the ANSYS program has been used, which allows simulating the stress-strain state of the kinetic pair of the pivot connection of the crank mechanism of engines with external heat supply and excluding cumbersome field tests of experimental samples. The dependence of stresses on the contact surface of the bushing on the depth of the boring in relation to its total length has experimentally been established.

Keywords: cast iron, heat engine, pivot connection, numerical modeling, stress-strain state

INTRODUCTION

There is a problem associated with decreasing reliability of the crank mechanism of engines with external heat supply due to mechanical wear of the kinetic pair of the pivot connection. For manufacturing the bushing, gray cast iron (LGI) is used, and for the pin, high-carbon steel grade CT45H. This pair has low wear resistance but at the same time it is possible to reuse a worn-out bushing several times during several overhaul periods.

Initially, the customer of the project formed the terms of reference for the use of materials and alloys for developing an engine with external heat supply and determined a fairly low budget. Therefore, it is not possible to use alloys with increased wear resistance.

The second argument of the customer is that there is the own production of cast iron bushings.

The aim is to develop a restoration method to improve cast iron bushings of pivot connections of heat engines with external heat supply, as well as to improve the efficiency of repairing cast iron bushings, their durability and wear resistance. The method should be simple to provide required reliability of the mechanism. The layout of a heat engine with external heat supply specimen is shown in Figure 1.

The analysis of literature has shown that various methods of treating cast iron [1] are quite successfully used, similar fractures of parts made of steel and cast

iron are given [2, 3], and the process of fatigue fracture is described in detail [4, 5]. The authors describe the mechanism of wear and destruction of cast iron parts [6]. The studies and practical observations have shown that the following factors are the main reasons for the failure of cast-iron bushings of pivot connections of heat engines with external heat supply: increased clearances caused by the bushing wear, contact stresses under loading, insufficient lubrication of surfaces. The developed methods make it possible to reduce the costs and the time for repair and restoration work.

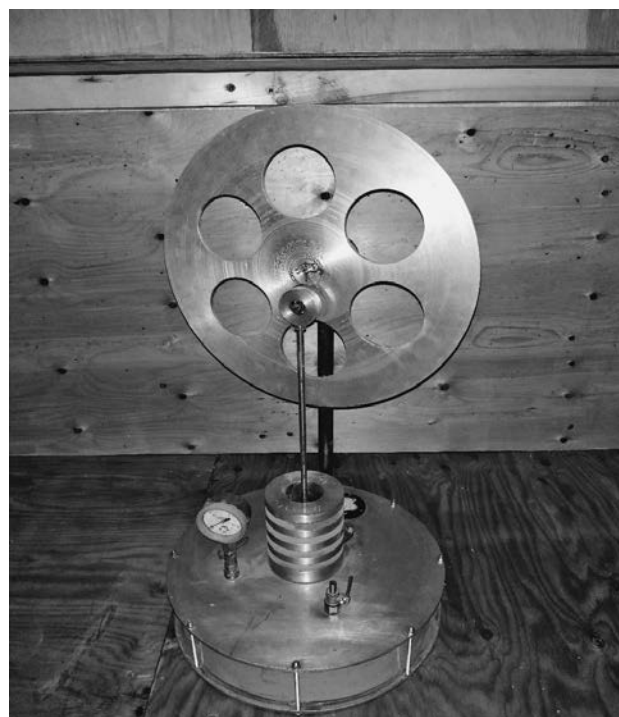

Figure 1 Specimen layout

A. D. Mekhtiyev, e-mail: barton.kz@mail.ru, National Research Tomsk Polytechnic University, Tomsk, Russia.

A. D. Mekhtiyev, Sarsikejev Y. Zh., S. Seifullin Kazakh Agro-Technical University, Nur-Sultan, Kazakhstan.

P. A. Kropachev F. N. Bulatbayev, Karaganda Technical University, Karaganda, Kazakhstan.

A. V. Yurchenko National Research Tomsk Polytechnic University, Tomsk, Russia.

The method of restoring the pivot bushing is performed without complete disassembly of the crank mechanism. The technology provides for boring a cylindrical bore of the bushing at the place of its mounting with a mobile milling device, which is fixed on the surfaces of the brake device elements, where it is necessary to restore the bushing. The essence of the method is to bore the bushing hole along its geometric axis with a cylindrical and conical cutter. The tapered part is 0,35 of the total bushing length. A pin of the corresponding configuration is placed in the bore hole of the bushing. It is economically feasible to use the bushing within two repair periods, without dismantling it and disassembling the entire mechanism. When re-restoring, the tapered part is bored for 0,7 of the total length of the bushing. The conical shape allows realizing self-alignment of friction surfaces and eliminating radial misalignment when mounting the pin, as well as limiting the end movement of the pin in the bushing during operation.

Due to the use of a tapered surface, the contact area of the bushing and pin surfaces increases, as a result of which the contact stresses under operational loads are reduced, and the bushing contact surfaces wear is reduced. There should be noted the economic feasibility of reusing the bushing within two repair periods, without dismantling it and disassembling the entire mechanism.

COMPUTER MODELING THE BUSHING SHAPE

To perform computer modeling, the ANSYS program has been used that allows simulating the stress-strain state of the kinetic pair of the pivot connection of the crank mechanism of engines with external heat supply and excluding cumbersome field tests of experimental specimens, using research methods described earlier in [7, 8].

Studying the simulation model of the bushing-pin pair using a computer have shown that the application of external loads will change the stress distribution in the area subject to wear. The computer model is shown in Figure 2.

The stresses σ in the contact zone of the bushing and the pin also depend functionally on the contact area and decrease with its increasing, represented by the dependence:

$$\sigma = f(L2 / L1)$$

Where: $L1$ - the total length, $L2$ - the depth of the boring.

The conical shape allows realizing the self-alignment property of the friction pair parts and eliminating radial misalignment when mounting the pin into the bushing, as well as limiting the end movement of the pin in the bushing during operation. The simulation results are shown in Figure 3. There is observed decreasing the contact stresses σ depending on the boring parameters; the total length $L1$ of the bushing is the depth of the boring $L2$, while the $L2 / L1$ ratio is observed. It can be argued that the durability and service life of the

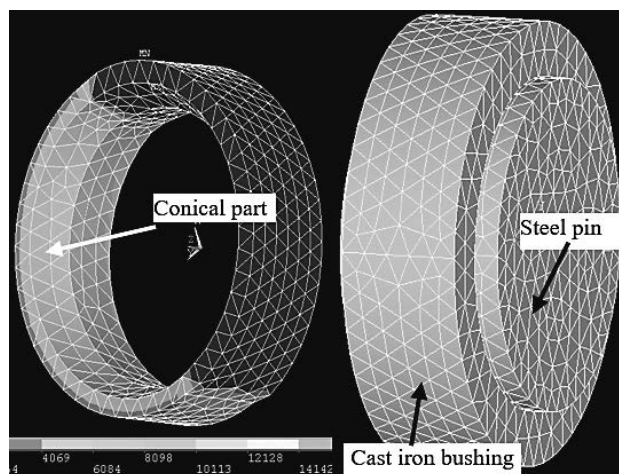

Figure 2 Computer model

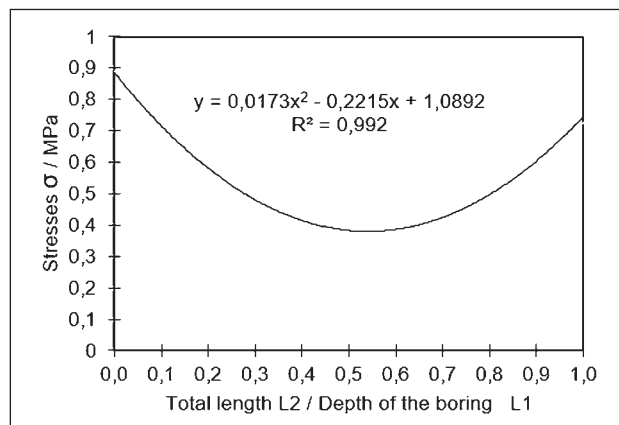

Figure 3 The bushing contact surface stresses dependence by the $L2 / L1$ ratio

bushing of the pivot connection of the mechanism is $L2 = 0,3 - 0,7$ of its full length $L1 = 1$.

EXPERIMENTAL STUDYING THE PROCESS OF PIVOT CONNECTION WEAR AND DEVELOPING THE METHOD OF THEIR RESTORATION

The dependence of stresses on the bushing contact surface on the depth of the bore in relation to its total length has been established experimentally. Due to the use of a tapered surface, the contact area of the bushing and pin surfaces increases, as a result of which the contact stresses under operational loads are reduced. Decreasing bushing wear occurs due to increasing the contact area of the bushing with the pin, since the area of contact along the surface of the body with the ABC generatrix is greater than the area of contact along the surface with the AK generatrix. The sum of the lengths of the sides AB and BC is greater than the length of the side AC therefore, the forming line with the ABC bend is more efficient than the straight line AC. When designing, point C (and accordingly the larger inner diameter of the bushing after boring) is determined from the condition of collapse of the bushing along the line ϕ_1 .

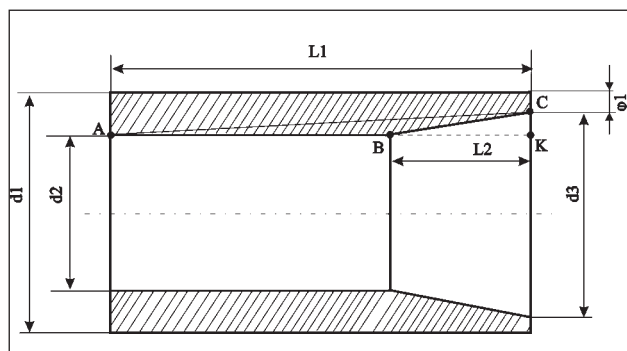

Figure 4 Longitudinal section of the bushing: L1 – bushing length; L2 - the depth of the inner tapered surface bore of the bushing; d1 - the outer diameter of the bushing; d2 - the inner diameter of the bushing; d3 - large inner diameter of the bushing after boring; γ - the minimum possible wall thickness of the bushing from the condition of collapse



Figure 5 Geometrical shape of the cast iron bushing inner surface: 1 - cylindrical bushing (standard); 2 - bushing with a partial conical bore of the inner cylindrical surface by 0,35 of its length; 3 - bushing with partial tapered bore of the inner cylindrical surface by 0,7 of its length

The angle of inclination $\angle CBK$ must be greater than the angle of the Morse cone (7°). At boring angles less than 7° , adhesion of the mating surfaces and jamming of the connection can appear. Analyzing the obtained dependence of stresses on the contact surface of the bushing on the depth of the boring allows determining the area of full-scale experiment on physical models. The taper bore depth ratio lies within the $L2 / L1 = 0,35 - 0,7$ of the total bushing length. The geometrical value of this phenomenon is shown in Figure 4.

The bushing bore options are as follows:

- the first option is a typical design with a cylindrical inner surface of the bushing along the AK line with the diameter d2;
- the second option has a partial conical bore of the inner surface of the bushing for 0,1 of its length along the ABC line with the diameters d2 and d3;
- the third option has a partial conical bore of the inner surface of the bushing for 0,35 of its length along the ABC line with the diameters d2 and d3;

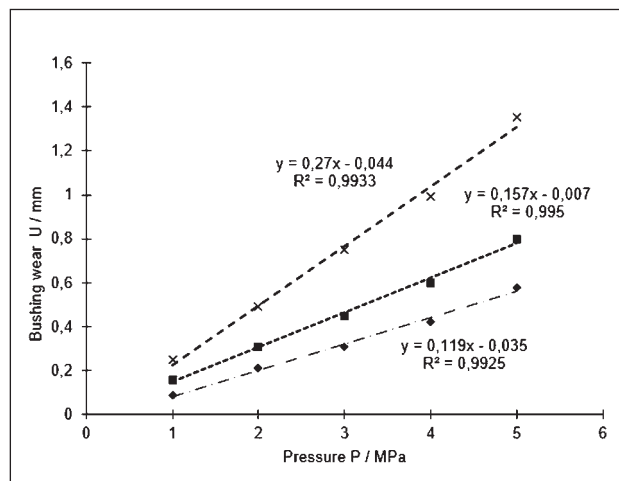

Figure 6 Graphs of changes the inner surface of the bushings depending on the load when testing the connection with different geometric parameters: 1 - cylindrical bushing; 2 - bushing with a partial conical bore of the inner cylindrical surface by 0,35 length; 3 - bushing with a partial tapered bore of the inner cylindrical surface by 0,7 of its length

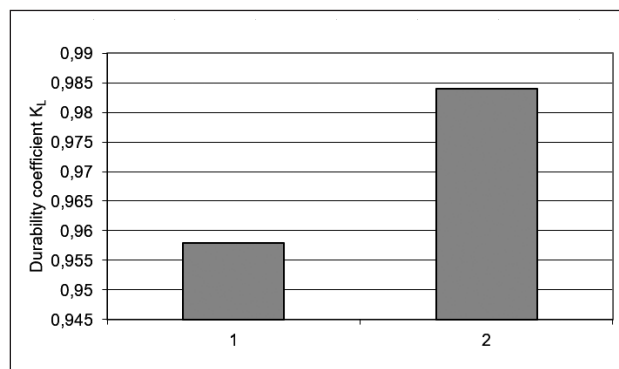

Figure 7 Utilization coefficient KL: 1 – cast iron cylindrical bushing; 2 – cast iron bushing with a conical bore

- the fourth option has a partial conical bore of the inner surface of the bushing for 0,7 of its length along the ABC line with the diameters d2 and d3;
- the fifth option has a full conical bore of the inner surface of the bushing for its entire length along the AC line with the diameters d2 and d3.

The task of the study is to determine the presence of significant changes on the surface of mating parts of pivot connections under various conditions. There are compared the friction surfaces of the connection and studied their physical, mechanical and tribological characteristics at various parameters of the cast iron bushing bore. Using the tribological friction machine SMC-2, the study of the main regularities of the pivot connection elements of the hinge joint was carried out to establish the parameters of wear in the area of the contact surfaces (Figure 5).

The values of the cast iron bushings of the pivot connection with different geometric parameters wear depending on the magnitude of the load have been experi-

mentally established. A pin is mounted inside the gray cast iron bushing, which is made of glued steel grade CT45X18H2M. The wear values have been set provided that the specified pressure is in the range from 1 to 5 MPa. The following one-factor dependences are obtained with the condition that the output parameter is the bushing wear U , and the input parameter is pressure P .

An important indicator that determines durability of the mechanism can be the coefficient of technical use K_T , which is equal to:

$$K_T = \frac{T_w}{T_w + \sum_{i=1}^n T_{pi}}$$

Where: K_T is the utilization coefficient;

T_w is the time of the mechanism some operation period, h; $\sum T_{pi}$ is the total durability of the machine repair within the same operation period, h.

The graphs of the dependences constructed based on the results of the experiment are shown in Figure 6.

The utilization coefficient taken for the period between the scheduled repairs and technical maintenance, is called the coefficient of availability K_G . The availability coefficient K_G evaluates the unforeseen stops of the mechanism, the presence of which indicates that the planned repairs and maintenance activities do not fully fulfill their role. K_G is numerically equal to the probability that the product will be operable at an arbitrarily taken moment in time in the intervals between planned maintenance and preventive measures. Therefore, as the main indicator of the product durability, the durability coefficient K_L should be used, which is equal to the coefficient of utilization taken over the entire period of operation. maximum K_L value is 1. The results of the utilization coefficient obtained experimentally are shown in Figure 7.

The time spent for repair and maintenance depends not only on the operation methods and repair technology but also on the design of the product, its suitability for repair and maintenance.

Constructive changes in the connection allow increasing the mechanism durability and the coefficient of technical utilization of K_T from 0,955 to 0,983. Increased indicators of maintainability in terms of time consumption $\sum T_{pi}$ by 2,5 times when using a tapered bore of the inner cylindrical surface of the cast iron

bushing. The developed method of restoration of cast iron bushings of pivot connections of a heat engine with external heat supply allows reusing a cast iron bushing, which reduces the cost of repairing the mechanism as a whole, as well as increasing the value of the utilization coefficient of the bushing and increasing its reliability.

Acknowledgements

The research is carried out according the project with S. Seifullin Kazakh Agrotechnical University and within the framework of Tomsk Polytechnic University Competitiveness Enhancement Program grant.

REFERENCES

- [1] L. Nofal, Novel Processing Techniques and Applications of Austemper Ductile Iron (Review), Technology and Journal of the University of Chemical Metallurgy 44 (2009) 3, 213-228.
- [2] Y. Murakami, T. Nomoto, T. Weda. Factors Influencing the Mechanism of Superlong Fatigue Failure in Steels, Fatigue & Fracture of Engineering Materials& Structures 22 (1999) 7, 581-590
- [3] Yang, J., Putatunda, S. K., Near threshold fatigue crack growth behavior of austempered ductile cast iron (ADI) processed by novel two-step austempering process, Materials Sci. and Engng A 393 (2005), 254 - 268.
- [4] K. Kanazawa, S. Nishijima. Fatigue Fracture of Low Alloy Steel at Ultra-High Cycle Regime under Elevated Temperature Conditions, Journal of the Society of Materials Science 46/12 (1997), 1396-1401.
- [5] A. Fatemi, L. Yang. Cumulative fatigue damage and life prediction theories: a survey of the state of art for homogeneous materials. Int. Journal Fatigue 20 (1998), 9-34.
- [6] V. Cocco, F. Iacoviello, A. Rossi. Fatigue damaging Micro-mechanisms in a Ferritic Ductile Cast iron, Italia, 2011, 13 -15
- [7] A.D. Mekhtiyev, F. N. Bulatbayev, A. V. Taranov, A. V. Bashirov, Ye. G. Neshina, A. D. Alkina. Use of reinforcing elements to improve fatigue strength of steel structures of mine hoisting machines (MHM), Metalurgija 59 (2019) 1, 121-124.
- [8] G. Simunovic, K. Simunovic, T. Saric. Modelling and simulation of surface roughness in face milling; International Journal of Simulation Modelling 12 (2013), 141-153.

Note: Translated from Russian into English by N. Drak, translator of Karaganda Technical University