



This is a repository copy of *Integrating a transfer perspective into evaluations of leadership training*.

White Rose Research Online URL for this paper:  
<https://eprints.whiterose.ac.uk/173105/>

Version: Published Version

---

**Article:**

Tafvelin, S., Hasson, H., Nielsen, K. [orcid.org/0000-0001-9685-9570](https://orcid.org/0000-0001-9685-9570) et al. (1 more author) (2021) Integrating a transfer perspective into evaluations of leadership training. *Leadership and Organization Development Journal*, 42 (6). pp. 856-868. ISSN 0143-7739

<https://doi.org/10.1108/LODJ-11-2019-0492>

---

**Reuse**

This article is distributed under the terms of the Creative Commons Attribution (CC BY) licence. This licence allows you to distribute, remix, tweak, and build upon the work, even commercially, as long as you credit the authors for the original work. More information and the full terms of the licence here:  
<https://creativecommons.org/licenses/>

**Takedown**

If you consider content in White Rose Research Online to be in breach of UK law, please notify us by emailing [eprints@whiterose.ac.uk](mailto:eprints@whiterose.ac.uk) including the URL of the record and the reason for the withdrawal request.

# Integrating a transfer perspective into evaluations of leadership training

Transfer of  
leadership  
training

Susanne Tafvelin

*Umeå University, Umeå, Sweden and*

*Department of Learning, Informatics, Management and Ethics, Karolinska Institutet,  
Stockholm, Sweden*

Henna Hasson

*Department of Learning, Informatics, Management and Ethics,  
Medical Management Centre, Karolinska Institutet, Stockholm, Sweden*

Karina Nielsen

*IWP, Sheffield University Management School, University of Sheffield,  
Sheffield, UK, and*

Ulrica von Thiele Schwarz

*Academy of Health, Care and Social Welfare, Mälardalen University, Eskilstuna,  
Sweden and*

*Department of Learning, Informatics, Management and Ethics,  
Medical Management Centre, Karolinska Institutet, Stockholm, Sweden*

Received 26 November 2019

Revised 22 December 2020

17 March 2021

13 April 2021

Accepted 14 April 2021

## Abstract

**Purpose** – In previous studies, outcomes of leadership training have varied, with some studies suggesting large effects and others small. Although the transfer of training literature suggests a number of factors that influence training outcomes, this knowledge has seldom been used when evaluating the outcomes of leadership training. The purpose of the present study is therefore to examine how factors related to transfer of training influence outcomes of leadership training.

**Design/methodology/approach** – In the present research, follower-rated outcomes of a leadership training program in Denmark ( $N = 298$ ) was examined from a transfer of training perspective.

**Findings** – Using Baldwin and Ford's transfer of training model as a framework, analyses revealed that leaders' utility reactions (i.e. perception of usefulness) and learning were linked to transfer of training. In addition, leaders' perceptions of transfer were associated with post-intervention follower-rated transformational leadership and collective self-efficacy.

**Practical implications** – Making sure that leaders find the training useful for their everyday activities (i.e. positive utility reactions) and that they have time to learn the training content is important to enable transfer and for leaders to use trained skills back at work.

**Originality/value** – The findings indicate the importance of understanding how leaders' perception of training content influences leadership training outcomes and that these perceptions need to be a part of the

© Susanne Tafvelin, Henna Hasson, Karina Nielsen and Ulrica von Thiele Schwarz. Published by Emerald Publishing Limited. This article is published under the Creative Commons Attribution (CC BY 4.0) licence. Anyone may reproduce, distribute, translate and create derivative works of this article (for both commercial and non-commercial purposes), subject to full attribution to the original publication and authors. The full terms of this licence may be seen at <http://creativecommons.org/licenses/by/4.0/legalcode>

This work was supported by the Joint Committee for Nordic Research Councils for the Humanities and Social Sciences (NOS-HS) under grant number 219610/F10. The Danish project was funded by the National Work Environment Research Fund, grant 16-2004-09.



---

evaluation of leadership training. In addition, the findings suggest that factors predicting transfer of leadership training differ from other types of training.

**Keywords** Evaluation of leadership training, Transfer of training, Utility reactions, Learning, Transformational leadership

**Paper type** Research paper

---

Recent studies suggest that leadership training has a positive impact on leadership behaviors and performance across a wide range of theories, outcomes, leadership levels and organization types. However, the range of effects has been found to be inconsistent, which calls for more research on factors that might explain when and why leadership training is effective (Avolio *et al.*, 2009).

One promising stream of research is the transfer of training literature. This literature suggests that for training to be effective and for trainees to use the trained skills back at work (i.e. training transfer), factors related to not only the individual but also the design of the training and the wider work environment must be considered (Baldwin and Ford, 1988; Blume *et al.*, 2010). These factors have, however, rarely been included in evaluations of leadership training.

The purpose of the present study is to examine how factors related to transfer of training influence outcomes of leadership training. We contribute to the existing literature in two ways. First, we use models of transfer of training to understand which factors may explain when and why leaders use trained skills back at work after attending leadership training. Second, we integrate the transfer of training literature into the evaluation of leadership training by examining how transfer is related to follower-rated outcomes of leadership training as a way to understand the often heterogeneous effects of these interventions. Understanding how leadership training impacts followers is important, as the reason for training leaders often is to help them to better manage their followers. Despite this, limited attention has been given to follower outcomes of leadership training (Nielsen and Daniels, 2012). Further, although the effectiveness of leadership training in general has been examined and confirmed in previous research (e.g. Collins and Holton, 2004; Lacerenza *et al.*, 2017), these studies have not focused on factors predicting transfer of leadership training.

### Transfer of training

Transfer of training is commonly viewed as consisting of two dimensions: generalization and maintenance. The former involves the extent to which skills and knowledge learned in training are applied in a different setting, while the latter captures the extent to which these newly acquired skills persist over time (Blume *et al.*, 2010). One common framework in the transfer of training literature is the model developed by Baldwin and Ford (1988). Their model suggests that effectiveness of training is influenced by training inputs (trainee characteristics, training design and work environment), training outputs in terms of learning (acquisition of knowledge and skills during training) and conditions of transfer (generalization of knowledge and skills acquired in training on the job and the maintenance of this learning over time on the job). Trainee characteristics include factors such as ability and motivation. Training design consists of factors including the objectives and methods of the training, as well as learning principles in terms of multiple training techniques. Work environment factors include the opportunities for or constraints to performing learned behaviors on the job (i.e. transfer climate) and social support from superiors and peers (Blume *et al.*, 2010). The model has been tested in numerous empirical studies, and existing meta-analyses support its assumptions (Alliger *et al.*, 1997; Blume *et al.*, 2010; Colquitt *et al.*, 2000).

The model has not been widely applied in leadership training interventions. Interestingly, the meta-analysis by Blume *et al.* (2010) found that the predictive value of self-efficacy, motivation and a positive work environment on transfer were in fact stronger for training of

soft skills (i.e. the intra- and interpersonal skills leadership training consists of), compared to closed skills such as training in a new computer program or a new machine. For other factors, such as cognitive ability and experience, the relationship with transfer was reversed or was nonsignificant for training of soft skills compared to closed skill. Although the number of leadership training interventions was small and mostly based on student samples, these mixed results call for a closer examination of predictors of transfer in leadership training interventions specifically. In addition, a recent meta-analysis on the effectiveness of leadership training concludes that leadership training is effective suggesting transfer does happen (Lacerenza *et al.*, 2017). Building on this, a next important step to advance the leadership training literature is to examine factors that predict such transfer. For an overview of the tested model in the current paper, see Figure 1.

### *Linking leader reactions to transfer of leadership training*

According to expectancy theory (Porter and Lawler, 1968), individuals are motivated to transfer skills learned during training if they perceive that their efforts are rewarded. One such reward may be the development of new leadership skills that enable leaders to manage their followers better. Expectancy theory suggests that the effort leaders put into leadership training is a function of the value and probability of improved leadership after training. This suggests that if leaders perceive the training as useful (i.e. the utility is high), they are more likely to expend effort using trained skills back at work (i.e. transfer learned skills into daily work practices).

Trainees' reactions to training, for example, positive attitudes toward training, have been extensively used in evaluations of training programs. In a meta-analysis of the relationship between training reactions and training criteria, Alliger *et al.* (1997) found that the relationship between trainee reactions and transfer differed depending on the type of reaction. Whereas affective reactions were not related to indicators of transfer, suggesting that liking the training does not automatically lead to transfer of training, utility reactions were useful in terms of finding whether the training was useful. This finding concerning affective and utility reactions was confirmed in a more recent meta-analysis (Blume *et al.*, 2010). Utility reactions are thought to increase transfer such that training that is perceived as useful, relevant and valuable for helping trainees perform their job increases the likelihood of trainees using the trained skills back at work (Burke and Hutchins, 2007) as suggested by expectancy theory (Porter and Lawler, 1968). In line with these arguments, we propose

- H1.* Leader utility reactions will be positively associated with transfer of leadership training.

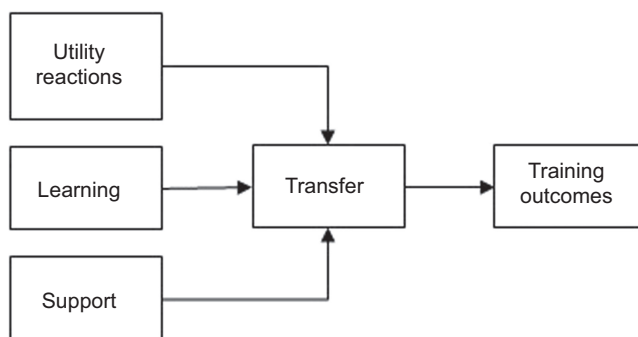

**Figure 1.**  
Hypothesized model in  
the present study

---

*Support and transfer of leadership training*

One of the most salient aspects of the work environment related to transfer is support from peers and superiors. Social identity theory (SIT) may explain why superior and peer support result in increased transfer. SIT postulates that we define our sense of self in terms of group membership, and groups provide us with personal security, companionship, intellectual stimulation and emotional bonding. Furthermore, SIT suggests that the extent to which individuals identify with the group and superior they work with (i.e. a shared social identity) will increase their motivation to perform behaviors that are important and relevant to that identity (Haslam *et al.*, 2009). By experiencing support from superiors, peer trainees' perception of social identity is enhanced, and thereby the motivation to apply trained skills, such as new leadership behaviors, back at work is increased. When trainees return to an environment where peers are supportive, they may be more likely to apply skills learned during the training course. Also, when trainees feel supported by their superior, they may feel more encouraged to try out new behaviors at work.

Both forms of support have been found to be positively related to trainees utilizing trained competencies in the workplace (Burke and Hutchins, 2007; Reinhold *et al.*, 2018). Superior support, in terms of direct feedback, provision of resources and information sharing has been identified as predicting transfer of training (Awoniyi *et al.*, 2002). In a study of leadership training, Cromwell and Kolb (2004) found that high levels of superior support were related to transfer of knowledge and skills a year after participation in leadership training. Support from peers and colleagues has also shown to influence trainee transfer. Thus, observing others using trained skills and having the possibility to coach one another facilitate transfer (Gilpin-Jackson and Bushe, 2007). In a study of a leadership training intervention, high levels of peer support were related to transfer of knowledge and skills a year later (Cromwell and Kolb, 2004). In sum, both superior and peer support facilitate transfer of training, and we therefore suggest

H2. Support, including superior and peer support, will be positively associated with transfer of leadership training.

*The importance of learning for transfer of leadership training*

It has generally been assumed that trainee learning is important for training to be transferred. The reason for this assumption is the idea that in order for trainees to use trained skills back at work (i.e. transfer) training material must first be learned and retained, and learning is therefore essential for transfer to occur (Kirkpatrick, 1994). Assessing learning can include tests on declarative or procedural knowledge, but also the assessment of mental models and changed attitudes. Early empirical studies confirmed the importance of learning for transfer in terms of declarative knowledge (Tannenbaum *et al.*, 1991). A later meta-analysis (Alliger *et al.*, 1997) casts doubt over the importance of learning. Learning was found to be positively related to transfer of training, but utility reactions were found to be more strongly correlated with transfer of training than learning (Alliger *et al.*, 1997); these findings were, however, based on a small number of studies. One explanation for this unexpected finding is that objective measures of learning indicate whether trainees have acquired knowledge, but not whether they will be able to use it at work. In a study of a global leadership development program, leaders' learning in terms of feedback-seeking and reflection was related to transfer of training (Sparr *et al.*, 2017). Building on previous research we propose that leader learning, in terms of changes in mental models and attitudes, will be positively related to transfer of leadership training.

H3. Leader learning is positively associated with transfer of leadership training.

*Linking transfer to outcomes of leadership training*

The model proposed by Baldwin and Ford (1988) does not distinguish between transfer and outcomes of the training. Although this link would appear to be of central interest, this

---

relationship has been neglected in previous research. This gap in the literature could be due to the fact that models of intervention evaluation and models of transfer of training are often not combined, and studies of transfer often do not include more distal outcomes (Blume *et al.*, 2010; Ford *et al.*, 2018). Some researchers distinguish between near and far transfer, whereby far transfer includes situations that are quite different from the learning situation (Blume *et al.*, 2010). Far transfer would usually be the case in leadership training, and in these situations far transfer may overlap with training outcomes, for example, the perception of changed leadership behavior, which could help explain the apparent lack of studies in this area. In the latest meta-analysis of transfer by Blume *et al.* (2010), the only empirical examination of this relationship reported that transfer was correlated with post-training self-efficacy. We argue that it is important to integrate models of training evaluation with models of transfer, especially in the case of leadership training interventions, to ensure that transferred skills have the intended effect in the organization. In the present study, we therefore propose that the extent to which leaders perceive that they have changed their routines because of the training (i.e. transfer) will be positively related to follower-rated outcomes of the leadership training. Within the transfer literature this relationship could also be conceptualized as near transfer predicting far transfer, and calls have been made to examine this relationship more closely (Blume *et al.*, 2010). We include two primary outcomes based on the objective of our specific leadership training, which in our case corresponds to transformational leadership and collective self-efficacy. Transformational leadership is based on a strong identification with the leader and the social unit in which the leadership takes place. The transformational leader raises follower awareness of moral values and uses inspiring visions to encourage followers to transcend their own personal interest for the collective good (Bass and Riggio, 2006). Collective self-efficacy refers to “a group’s shared belief in its conjoint capabilities to organize and execute the courses of action required to produce given levels of attainments” (Bandura, 1997, p. 477). Building on the above, we suggest

- H4. Transfer of leadership training is positively associated with training outcomes in terms of transformational leadership.
- H5. Transfer of leadership training is positively associated with training outcomes in terms of collective self-efficacy.

## Method

### *The leadership training*

The training course consisted of six full-days’ training modules spread over a period of six months; modules were conducted at one month intervals. Two modules were merged into a two-day course due to their similarity in content. The research team developed a review based on current theory and research on implementing and managing teams, and experienced occupational health consultants translated this into a syllabus for the training. The six modules included one module of training on key characteristics of teams and how to identify to which extent the leader’s group already worked as a team. The second module focused on the key characteristics of transformational leadership including practical exercises as this type of leadership has been found to support teamwork (Cheng *et al.*, 2016; Miao and Cao, 2019; Nielsen *et al.*, 2009). The two-day module (modules three and four) focused on how leaders can make changes in their teams and subsequently leaders developed action plans. The fifth module focused on the progress of action plan implementation. As part of this module, leaders were asked to write an essay about their experiences with making changes that had hindered and facilitated the implementation of action plans. The sixth and final module focused on learning and evaluation. Partly based on the essay, leaders reflected on what had gone well and what had not gone according to plan and how they would use

---

learning from the training program in the future. Each organization underwent their own individual training to ensure discussions and knowledge sharing focused on the reality of participants (Burke and Hutchins, 2007) and keeping the class size below 20.

#### *Participants and procedure*

Two organizations, an accounting firm and an elderly care center (both located in Denmark) participated in the study. In each organization, 30 line managers were selected to participate in the training. A total of 60 line managers were recruited and were randomly selected to attend training. In this study, we only include the participants of the training course because we are studying the transfer of training. Three months prior to leadership training, a baseline questionnaire was distributed to the leaders' subordinates asking them to rate their leader's transformational leadership and their collective self-efficacy. All the subordinates of the leaders were invited to participate; no selection was made. In addition, subordinates were not informed if their leader went to training or not. Nine months post-training, the subordinates received a follow-up questionnaire consisting of measures of transformational leadership and collective self-efficacy, while the leaders received a questionnaire with questions on perceived support, learning and transfer of training. A total of 36 leaders completed either or both of the pre- and post-intervention questionnaires. The mean age of these managers was 40.88 at Time 1 (Standard Deviation (SD) = 9.71), 58% were female and the mean tenure in the company was 10.55 (SD = 4.61).

All the subordinates of the leader completed pre- and post-training questionnaires, but for the purpose of this study only subordinates who completed both the pre- and postmeasures were included. At the accounting firm 143 of 174 subordinates returned the questionnaire (response rate 82%) at Time 1, and 120 of these 143 subordinates also responded at Time 2. At the elderly care center, 316 of 427 subordinates returned the questionnaire (response rate 74%) at Time 1, and 178 of these 316 subordinates also returned it at Time 2. Thus, the final sample was 298 subordinates (120 representing the accounting firm and 178 the elderly care center). In this sample, the mean age at Time 1 was 37.02 (SD = 12.63), and 76% were female; at Time 2, the mean age was 39.21 (SD = 12.34), and 69% of the sample were female. On average, each leader had nine responding subordinates. We conducted dropout analyses to explore attrition from T1 to T2. Analyses revealed no significant differences between those who only responded at T1 to those who responded both times in terms of gender, age and perceptions of transformational leadership and collective self-efficacy.

#### *Outcome measures*

*Transformational leadership.* Transformational leadership was measured using the seven item Global Transformational Leadership Scale (Carless et al., 2000). This scale measures the central dimensions of intellectual stimulation, inspirational motivation, idealized influence and individualized consideration. A five-point Likert scale for each item ranging from "To a very large extent" to "To a very small extent" was used, and coefficient alpha was 0.91 at Time 1 and 0.92 at Time 2.

*Collective self-efficacy.* Collective self-efficacy was measured with a four-item scale by Salanova et al. (2003). An example of an item is: "My group is able so solve difficult tasks if we invest the necessary effort". Response categories were "1 = Always", "2 = Often", "3 = Sometimes", "4 = Rarely" and "5 = Hardly ever/never". For the analysis, the scale was reversed such that a high value represents a high level of team efficacy. Coefficient alpha for this scale was 0.92 at Time 1 and 0.94 at Time 2.

#### *Measures of the transfer process*

The measures of utility reactions and support were developed for this study, while the measures of learning and transfer of training were adapted from Randall et al. (2009).



---

All measures of the transfer process were collected after the intervention at Time 2, except for utility reactions which were measured after each training session. Many of the items were also tailored to fit the overall focus of the intervention; the implementation of teams, which is a recommended approach when evaluating organizational interventions (Nielsen *et al.*, 2014).

*Utility reactions.* We measured leaders' perception of usefulness of the training with three items after each training session (five in total): "Did you get something out of class today?", "Will you be able to transfer what you learned today?", and the delta value of the two questions "What were your expectations for today?" and "Did today live up to your expectations?". We calculated the mean over the five sessions for the first two questions, and the mean of the delta value for the last two questions as a way to capture if the training exceeded their expectation. Responses on these questions were given on a four-point scale ranging from 1 (to a very little extent/no expectations) to 4 (to a very high extent/very high expectations). Coefficient alpha for this scale was 0.82.

*Support.* We measured support with three items at Time 2: "My colleagues have shown a lot of interest in being involved in the process of implementing teams", "The management in this organization has done a lot to involve staff in the process of implementing teams", and "I have had the authority to take the decision to implement teams". A five-point Likert scale for each item ranging from "Always" to "Never/Hardly ever" was used. Coefficient alpha for the three items was 0.76 at Time 2.

*Learning.* We measured learning in terms of changed attitudes, which is in line with the definitions of learning provided by Kirkpatrick (1994). We used three items from the process evaluation measure developed by Randall *et al.* (2009): "My attitudes about the leader role have changed since the implementation of teams", "My attitudes about teams have changed since the implementation of teams", and "My attitudes about routines and ways of working have changed since the implementation of teams". Responses to these items were given on a five-point scale ranging from 1 (strongly agree) to 5 (highly disagree). Coefficient alpha was 0.88.

*Transfer of training.* We operationalized transfer of training as the perception of changes in procedures since the implementation of teams was measured with a scale for changes in procedures developed by Randall *et al.* (2009). This scale consists of four items: "I have changed routines and procedures since the implementation of teams", "Through the implementation of teams we have finally been able to straighten up some bad methods/procedures that we had acquired", "In this change we openly discuss which traditions or procedures we want to change and which ones we want to keep", and "The implementation of teams has made it easier to tackle the changes in the organization". Responses to these items were given on a five-point scale ranging from 1 (strongly agree) to 5 (highly disagree). Coefficient alpha was 0.75.

### *Analysis*

Statistical analyses were performed using multilevel path analysis in Mplus. We first investigated if followers working for the same leader shared similar perceptions of transformational leadership and collective efficacy by computing the intraclass correlations (ICC; see Heck, 2001) and then tested our hypothetical model. The leader rated measures of the transfer process had no individual-level variance among followers and were therefore only modeled at the team level. Training outcomes were rated by followers and modeled at both the individual and team levels. Model fit was assessed by means of the root mean square error of approximation (RMSEA), the Tucker–Lewis Index (TLI), the Comparative Fit Index (CFI), and standardized root mean square residual (SRMR) based on Hu and Bentler's (1999) recommendations.



**Results**

In Table 1, summary statistics and correlations for all variables are presented. A paired-samples *t*-test between T1 and T2 were used to identify any significant effects of the leadership training across the sample as a whole. These revealed that transformational leadership [*t* (297) -2.28, *p* < 0.05] improved significantly, while collective efficacy was unaffected by the training [*t* (297) 0.99, *p* = 0.33]. These results showed that without considering within-intervention group variability in reports of utility reactions, learning and support, it would have been reasonable to conclude that the training had mixed and modest effects. The intraclass correlation coefficients for transformational leadership and collective efficacy scales were significant at the between level, suggesting that 13–16% of the variance was explained at the team level. This indicated that multilevel analyses were appropriate in order to test the hypothetical model.

A good fit was found of the hypothesized multilevel model to the observed covariance structure ( $\chi^2 = 17.90$ , *df* = 12, CFI = 0.96, TLI = 0.92, RMSEA = 0.04, SRMR within = 0.08, between = 0.09). The multilevel model is presented in Figure 2, with the upper part describing the between-level model and the lower part the within-level model.

In support of Hypothesis 1, leaders’ utility reactions to the leadership training were significantly related to transfer of training ( $\beta = 0.18$ , *p* < 0.05) at Time 2. Contrary to the Hypothesis 2, support was not related to transfer of training. In line with Hypothesis 3, leader learning was associated with transfer of training ( $\beta = 0.73$ , *p* < 0.001.). Finally, in support of Hypothesis 4 and 5, transfer was associated with training outcomes in terms of transformational leadership ( $\beta = 0.41$ , *p* < 0.01.) and collective self-efficacy ( $\beta = 0.29$ , *p* < 0.01.) at Time 2, respectively.

**Discussion**

In the present study we examined how factors related to the transfer process are associated with training outcomes. The main contribution of this paper is that it includes factors that can explain why these interventions work or when they are the most effective, shedding light on the often heterogeneous effects in previous research (Avolio *et al.*, 2009).

The results of testing the first Hypothesis lend support to the argument that positive utility reactions are important for leadership training to be transferred. This is in line with expectancy theory (Porter and Lawler, 1968) and previous studies of transfer of training in

Scale	<i>M</i>	<i>SD</i>	1	2	3	4	5	6	7	8
1. TFL T1	60.63	19.54	(0.91)							
2. TFL T2	63.10	18.90	0.50**	(0.92)						
3. Collective self-eff T1	80.26	18.60	0.26**	0.11	(0.92)					
4. Collective self-eff T2	76.70	20.35	0.19**	0.38**	0.38**	(0.94)				
5. Transfer	53.85	13.89	0.05	0.20**	-0.04	0.12*	(0.75)			
6. Learning	2.75	0.78	0.03	0.12*	0.02	0.11	0.76**	(0.88)		
7. Utility	2.19	0.10	-0.02	-0.02	0.25**	0.19**	0.27**	0.02	(0.79)	
8. Support	2.47	0.71	0.13*	0.16**	0.10	0.20**	0.31**	-0.13**	0.30**	(0.77)

**Note(s):** *N* = 298 followers working with 36 leaders; for correlations between follower data and leader data, leader values were disaggregated to each follower. Internal consistency reliabilities are on the diagonal, in parentheses. TFL = Transformational leadership. The TFL, collective self-efficacy and transfer scales were transformed to facilitate interpretation, so they ranged from 0 to 100 with 100 representing a high score on the construct; \**p* < 0.05, \*\**p* < 0.01

**Table 1.** Descriptive statistics and correlation between all study variables

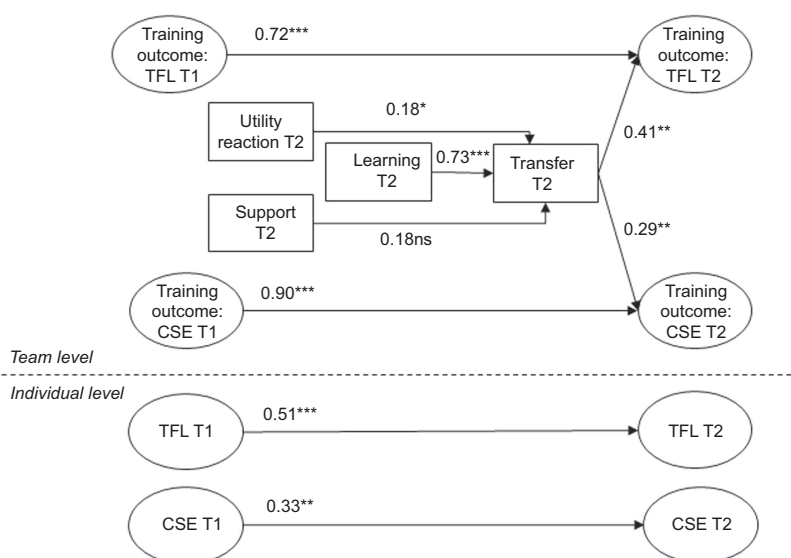

**Source(s):** TFL = Transformational leadership behaviour, CSE = Collective Self-Efficacy

**Note(s):** \* $p < 0.05$ , \*\* $p < 0.01$ , \*\*\* $p < 0.001$

**Figure 2.** Multilevel model of the role of the transfer process for explaining training outcomes

other types of interventions (Alliger *et al.*, 1997). Our study suggests that this also holds in leadership training interventions. From a practical perspective, the findings highlight issues that should be considered during the development of leadership training interventions, and matching the intervention to the needs of the participants may be one way to increase the likelihood of positive utility reactions. Training need analysis may be one way to do this (Salas *et al.*, 2012). Also, continuous and systematic measurement of participants' perceptions of usefulness while conducting a leadership training may be helpful in order to be able to revise the training and optimize utility reactions and thereby increase transfer of knowledge and skills to leaders' everyday job.

Our results do not support Hypothesis 2 that peer and superior support is associated with transfer of leadership training. This is in contrast to previous research on other types of training, which suggests that peer and superior support are important factors for training to be transferred (Blume *et al.*, 2010). It is possible that leadership training is different from other types of training such as staff training and not dependent on peer and superior support to the same extent but rather on the support of subordinates. The support of peers and superiors may not be as important as they are not directly involved in the relationship between leaders and their subordinates. The importance of subordinates' perceptions has been found in a study by Nielsen and Daniels (2012); however, more studies are needed to clarify this.

In line with previous studies, leaders' perceptions of learning during the leadership training were related to transfer of training (Alliger *et al.*, 1997), lending support to Hypothesis 3. The findings in the literature regarding the role learning plays in transfer are inconsistent. On the one hand, learning is crucial for transfer; but on the other, studies vary regarding whether learning is affected or unaffected by trainee characteristics, training design and contextual factors (Alliger *et al.*, 1997). This is an important avenue for future research to examine the circumstances under which learning is or is not affected by training inputs.

---

In our study, both of our follower-rated outcomes were associated with leaders' self-rated perceptions of transfer, supporting Hypothesis 4 and 5. This link is rarely tested in the transfer of training literature (Blume *et al.*, 2010), but we argue that it is important to examine whether the training has led to any changes in the intended direction given in the training and to investigate the association between leader-rated changes and follower perceptions of outcomes. Previous studies have demonstrated that transformational leadership training can positively impact followers' attitudes in terms of commitment, self-efficacy and resilience as well as performance (Barling *et al.*, 1996; Dvir *et al.*, 2002; Hardy *et al.*, 2010). In the present study, we combine training transfer with evaluation, which considerably strengthens the evaluation of training. Our findings that self-rated transfer was associated with follower-rated outcomes also supports the idea of generalization (i.e. that skills learned in training are applied in a different setting) that is part of the definition of the transfer concept. The degree to which these skills were maintained over a longer period of time remains, however, unknown.

### *Implications*

From a research perspective, our findings raise a number of questions regarding the transfer process of leadership training that deserves further research attention. Although our study shows that Baldwin and Ford's (1988) transfer model may be useful for understanding transfer of leadership training (i.e. the role of learning and utility reactions), our findings also imply that the transfer process of leadership training (i.e. training in soft and interpersonal skills) may be different than other types of training (i.e. the role of support). This is in line with the meta-analysis by Blume *et al.* (2010) who found that training of soft and closed skills, as well as field and experimental studies differed in magnitude and direction of influence regarding different predictors' ability to predict transfer. Our results open up a new avenue of research investigating other well-known predictors of transfer in relation to leadership training as well as identifying additional factors influencing transfer that may be specific to leadership training. We suggest that it may be of interest to examine the role of followers and their influence on leaders' ability to transfer knowledge and skills after training, including followers' readiness for change, stress-levels and support, as well as how often the leader meets and interacts with his or her employees.

From a practical perspective, our findings point toward the importance of designing a leadership training that is perceived as meaningful and that provides opportunities for learning. As mentioned previously, to increase leaders' perceived utility of the training, we suggest that organizers of leadership training programs perform a training need analysis before the training to match the training to the needs of the participants (Salas *et al.*, 2012). Also, systematic feedback from participants in relation to the perceived usefulness of the leadership training may be helpful to revise the training content continuously. To promote learning, we suggest that organizers of leadership training programs address leaders' different learning strategies by providing a mixture of lectures, role-play and case work.

### *Limitations*

There are a number of limitations that should be considered when interpreting the results. First, we did not include nonintervention groups, which means that whereas we can investigate the changes over time, we do not know whether they were related to the interventions or to other factors (Shannon *et al.*, 1999). Instead, we capitalize on the variation among the trained leaders. In fact, a control group that had not been exposed to the training would have added little understanding to the process of transferring training to practice. Instead of adding a control group, future studies may focus on experimentally varying the transfer factors, thereby providing more rigorous tests of the relationships proposed in this

---

study. A second limitation is the use of leaders' self-ratings for the measures of the transfer process. Although the measures' reliabilities were satisfactory, further instrument development and psychometric testing is warranted in future research. The use of self-ratings also increases the risk of common method and common source bias (Podsakoff *et al.*, 2003). However, only leaders can provide us with their perceptions of the transfer process such as if they found the training useful, and we used follower ratings, for example, not the same source, for training outcomes. The use of multiple raters may reduce the threat of common method bias, and in line with the recommendations of Podsakoff *et al.* (2003), we also employed a number of procedural study design remedies to reduce the susceptibility of our data. These included assurances of respondent confidentiality, use of different questionnaire sections, instructions and response scales for different measures. Finally, we used a combined measure of peer and superior support. We were therefore unable to distinguish between the two types of support. Future research may study these types of support separately to examine their specific influence on leaders' transfer after attending leadership training.

## Conclusions

The main contributions of the present research are twofold. First, our study shows that transfer of training may be a useful framework for understanding factors that can explain if leaders will use trained skills back at work after attending leadership training. Second, we integrate the transfer of training literature into evaluations of outcomes of leadership training as a means to understand when and why leadership training leads to improvements not only in leadership behavior but also in terms of improved follower attitudes. Our results highlight the importance of understanding the transfer process, including the role of utility reactions and learning, when designing and implementing leadership training that will transfer and ultimately translate into desired follower outcomes.

## References

- Alliger, G., Tannenbaum, S., Bennett, W., Traver, H. and Shotland, A. (1997), "A meta-analysis of the relations among training criteria", *Personnel Psychology*, Vol. 50, pp. 341-359, doi: [10.1111/j.1744-6570.1997.tb00911.x](https://doi.org/10.1111/j.1744-6570.1997.tb00911.x).
- Avolio, B.J., Reichard, R.J., Hannah, S.T., Walumbwa, F.O. and Chan, A. (2009), "A meta-analytic review of leadership impact research: experimental and quasi-experimental studies", *The Leadership Quarterly*, Vol. 20 No. 5, pp. 764-784, doi: [10.1016/j.leaqua.2009.06.006](https://doi.org/10.1016/j.leaqua.2009.06.006).
- Awoniyi, E.A., Griego, O.V. and Morgan, G.A. (2002), "Person-environment fit and transfer of training", *International Journal of Training and Development*, Vol. 6, pp. 25-35, doi: [10.1111/1468-2419.00147](https://doi.org/10.1111/1468-2419.00147).
- Baldwin, T.T. and Ford, J.K. (1988), "Transfer of training: a review and directions for future research", *Personnel Psychology*, Vol. 41 No. 1, pp. 63-105, doi: [10.1111/j.1744-6570.1988.tb00632.x](https://doi.org/10.1111/j.1744-6570.1988.tb00632.x).
- Bandura, A. (1997), *Self-efficacy: The Exercise of Control*, Freeman, New York.
- Barling, J., Weber, T. and Kelloway, E.K. (1996), "Effects of transformational leadership training on attitudinal and financial outcomes: a field experiment", *Journal of Applied Psychology*, Vol. 81 No. 6, p. 827, doi: [10.1037/0021-9010.81.6.827](https://doi.org/10.1037/0021-9010.81.6.827).
- Bass, B.M. and Riggio, R.E. (2006), *Transformational Leadership*, Psychology Press, London.
- Blume, B.D., Ford, J.K., Baldwin, T.T. and Huang, J.L. (2010), "Transfer of training: a meta-analytic review", *Journal of Management*, Vol. 36 No. 4, pp. 1065-1105, doi: [10.1177/0149206309352880](https://doi.org/10.1177/0149206309352880).
- Burke, L.A. and Hutchins, H.M. (2007), "Training transfer: an integrative literature review", *Human Resource Development Review*, Vol. 6, pp. 263-96, doi: [10.1177/1534484307303035](https://doi.org/10.1177/1534484307303035).

- Carless, S.A., Wearing, A.J. and Mann, L. (2000), "A short measure of transformational leadership", *Journal of Business and Psychology*, Vol. 14 No. 3, pp. 389-405, doi: [10.1023/A:1022991115523](https://doi.org/10.1023/A:1022991115523).
- Cheng, C., Bartram, T., Karimi, L. and Leggat, S. (2016), "Transformational leadership and social identity as predictors of team climate, perceived quality of care, burnout and turnover intention among nurses", *Personnel Review*, Vol. 45 No. 6, pp. 1200-1216.
- Collins, D.B. and Holton, E.F. (2004), "The effectiveness of managerial leadership development programs: a meta-analysis of studies from 1982 to 2001", *Human Resource Development Quarterly*, Vol. 15 No. 2, pp. 217-248.
- Colquitt, J.A., LePine, J.A. and Noe, R.A. (2000), "Toward an integrative theory of training motivation: a meta-analytic path analysis of 20 years of research", *Journal of Applied Psychology*, Vol. 85, pp. 678-707, doi: [10.1037/0021-9010.85.5.678](https://doi.org/10.1037/0021-9010.85.5.678).
- Cromwell, S.E. and Kolb, J.A. (2004), "An examination of work-environment support factors affecting transfer of supervisory skills training to the workplace", *Human Resource Development Quarterly*, Vol. 15, pp. 449-71, doi: [10.1002/hrdq.1115](https://doi.org/10.1002/hrdq.1115).
- Dvir, T., Eden, D., Avolio, B.J. and Shamir, B. (2002), "Impact of transformational leadership on follower development and performance: a field experiment", *Academy of Management Journal*, Vol. 45 No. 4, pp. 735-744, doi: [10.2307/3069307](https://doi.org/10.2307/3069307).
- Ford, J.K., Baldwin, T. and Prasad, J. (2018), "Transfer of training: the known and the unknown", *Annual Review of Organizational Psychology and Organizational Behavior*, Vol. 5, pp. 201-225.
- Gilpin-Jackson, Y. and Bushe, G.R. (2007), "Leadership development training transfer: a case study of post-training determinants", *Journal of Management Development*, Vol. 26 No. 10, pp. 980-1004, doi: [10.1108/02621710710833423](https://doi.org/10.1108/02621710710833423).
- Hardy, L., Arthur, C.A., Jones, G., Shariff, A., Munnoch, K., Isaacs, I. and Allsopp, A.J. (2010), "The relationship between transformational leadership behaviors, psychological, and training outcomes in elite military recruits", *The Leadership Quarterly*, Vol. 21 No. 1, pp. 20-32, doi: [10.1016/j.leaqua.2009.10.002](https://doi.org/10.1016/j.leaqua.2009.10.002).
- Haslam, S.A., Jetten, J., Postmes, T. and Haslam, C. (2009), "Social identity, health and well-being: an emerging agenda for applied psychology", *Applied Psychology*, Vol. 58 No. 1, pp. 1-23, doi: [10.1111/j.1464-0597.2008.00379.x](https://doi.org/10.1111/j.1464-0597.2008.00379.x).
- Heck, R.H. (2001), "Multilevel modeling with SEM", in Marcoulides, G.A. and Schumacker, R.E. (Eds), *New Developments and Techniques in Structural Equation Modelling*, Lawrence Erlbaum Associates, book-chapter, Mahwah, NJ, pp. 89-127.
- Hu, L. and Bentler, P.M. (1999), "Cutoff criteria for fit indexes in covariance structure analysis: conventional criteria versus new alternatives", *Structural Equation Modeling*, Vol. 6, pp. 1-55, doi: [10.1080/10705519909540118](https://doi.org/10.1080/10705519909540118).
- Kirkpatrick, D.L. (1994), *Evaluating Training Programs: The Four Levels*, Berrett-Koehler, San Francisco, CA, (Original work published 1959).
- Lacerenza, C.N., Reyes, D.L., Marlow, S.L., Joseph, D.L. and Salas, E. (2017), "Leadership training design, delivery, and implementation: a meta-analysis", *Journal of Applied Psychology*, Vol. 102 No. 12, pp. 1686-1718.
- Miao, R. and Cao, Y. (2019), "High-performance work system, work well-being, and employee creativity: cross-level moderating role of transformational leadership", *International Journal of Environmental Research and Public Health*, Vol. 16 No. 9, p. 1640.
- Nielsen, K. and Daniels, K. (2012), "Enhancing team leaders' well-being states and challenge experiences during organizational change: a randomized, controlled study", *Human Relations*, Vol. 65 No. 9, pp. 1207-1231, doi: [10.1177/0018726711433312](https://doi.org/10.1177/0018726711433312).
- Nielsen, K., Yarker, J., Randall, R. and Munir, F. (2009), "The mediating effects of team and self-efficacy on the relationship between transformational leadership, and job satisfaction and psychological well-being in healthcare professionals: a cross-sectional questionnaire survey", *International Journal of Nursing Studies*, Vol. 46 No. 9, pp. 1236-1244.

- 
- Nielsen, K., Abildgaard, J.S. and Daniels, K. (2014), "Putting context into organizational intervention design: using tailored questionnaires to measure initiatives for worker well-being", *Human Relations*, Vol. 67 No. 12, pp. 1537-1560.
- Podsakoff, P.M., MacKenzie, S.B., Lee, J.Y. and Podsakoff, N.P. (2003), "Common method biases in behavioral research: a critical review of the literature and recommended remedies", *Journal of Applied Psychology*, Vol. 88 No. 5, p. 879, doi: [10.1037/0021-9010.88.5.879](https://doi.org/10.1037/0021-9010.88.5.879).
- Porter, L.W. and Lawler, E.E. (1968), *Management Attitude and Performance*, Dorsey Press, Florence, KY.
- Randall, R., Nielsen, K. and Tvedt, S.D. (2009), "The development of five scales to measure employees' appraisals of organizational-level stress management interventions", *Work and Stress*, Vol. 23 No. 1, pp. 1-23, doi: [10.1080/02678370902815277](https://doi.org/10.1080/02678370902815277).
- Reinhold, S., Gegenfurtner, A. and Lewalter, D. (2018), "Social support and motivation to transfer as predictors of training transfer: testing full and partial mediation using meta-analytic structural equation modelling", *International Journal of Training and Development*, Vol. 22 No. 1, pp. 1-14.
- Salanova, M., Llorens, S., Cifre, E., Martínez, I.M. and Schaufeli, W.B. (2003), "Perceived collective efficacy, subjective well-being and task performance among electronic work groups an experimental study", *Small Group Research*, Vol. 34 No. 1, pp. 43-73, doi: [10.1177/1046496402239577](https://doi.org/10.1177/1046496402239577).
- Salas, E., Tannenbaum, S.I., Kraiger, K. and Smith-Jentsch, K.A. (2012), "The science of training and development in organizations: what matters in practice", *Psychological Science in the Public Interest*, Vol. 13 No. 2, pp. 74-101, doi: [10.1177/1529100612436661](https://doi.org/10.1177/1529100612436661).
- Shannon, H.S., Robson, L.S. and Guastello, S.J. (1999), "Methodological criteria for evaluating occupational safety intervention research", *Safety Science*, Vol. 31 No. 2, pp. 161-179, doi: [10.1016/S0925-7535\(98\)00063-0](https://doi.org/10.1016/S0925-7535(98)00063-0).
- Sparr, J.L., Knipfer, K. and Willems, F. (2017), "How leaders can get the most out of formal training: the significance of feedback-seeking and reflection as informal learning behaviors", *Human Resource Development Quarterly*, Vol. 28 No. 1, pp. 29-54.
- Tannenbaum, S.I., Mathieu, J.E., Salas, E. and Cannon-Bowers, J.A. (1991), "Meeting trainees' expectations: the influence of training fulfillment on the development of commitment, self-efficacy, and motivation", *Journal of Applied Psychology*, Vol. 76, pp. 759-769, doi: [10.1037/0021-9010.76.6.759](https://doi.org/10.1037/0021-9010.76.6.759).

### Corresponding author

Susanne Tafvelin can be contacted at: [susanne.tafvelin@umu.se](mailto:susanne.tafvelin@umu.se)

---

For instructions on how to order reprints of this article, please visit our website:

[www.emeraldgrouppublishing.com/licensing/reprints.htm](http://www.emeraldgrouppublishing.com/licensing/reprints.htm)

Or contact us for further details: [permissions@emeraldinsight.com](mailto:permissions@emeraldinsight.com)