



8-1-1969

A Tone Signature Analysis of Multispectral Photography

Michael V. Miller

Follow this and additional works at: <https://commons.und.edu/theses>

Recommended Citation

Miller, Michael V., "A Tone Signature Analysis of Multispectral Photography" (1969). *Theses and Dissertations*. 3672.

<https://commons.und.edu/theses/3672>

This Thesis is brought to you for free and open access by the Theses, Dissertations, and Senior Projects at UND Scholarly Commons. It has been accepted for inclusion in Theses and Dissertations by an authorized administrator of UND Scholarly Commons. For more information, please contact und.common@library.und.edu.

A TONE SIGNATURE ANALYSIS OF MULTISPECTRAL PHOTOGRAPHY

by

Michael V. Miller

Bachelor of Philosophy, University of North Dakota 1967

A Thesis

Submitted to the Faculty

of the

University of North Dakota

in partial fulfillment of the requirements

for the Degree of

Master of Science

Grand Forks, North Dakota

August
1969

T/1969
M61
C-1

This thesis submitted by Michael V. Miller in partial fulfillment of the requirements for the Degree of Master of Science from the University of North Dakota is hereby approved by the Faculty Advisory Committee under whom the work has been done.

Olson L. Youngren
(Chairman)

Bert L. Will

Lee Clayton

William Johnson
Dean of the Graduate School

Permission

Title A TONE SIGNATURE ANALYSIS OF MULTISPECTRAL PHOTOGRAPHY

Department Department of Geography

Degree Master of Science

In presenting this thesis, in partial fulfillment of the requirements for a graduate degree from the University of North Dakota, I agree that the Library of this University shall make it freely available for inspection. I further agree that permission for extensive copying for scholarly purposes may be granted by the professor who supervised my thesis work or, in his absence, by the Chairman of the Department or the Dean of the College in which my thesis work was done. It is understood that any copying or publication or other use of this thesis, or part thereof for financial gain shall not be allowed without my written permission. It is also understood that due recognition shall be given to me and to the University of North Dakota in any scholarly use which may be made of any material in my thesis.

Signature Michael V. Miller

Date July 31, 1969

ACKNOWLEDGEMENTS

The writer would like to express his appreciation to Professor Duane L. Younggren, Chairman, Department of Geography, Dr. Bernt L. Wills, Department of Geography and Dr. Lee Clayton, Department of Geology, for their criticism and advice during the preparation of the manuscript and for their service as members of the examining committee.

The writer also wishes to thank Professor J. Ronald Eyton, Department of Geography, for his advice and assistance in the photography and photographic theory that made this study possible.

A special note of appreciation is extended to the author's wife and son, Scottie and Greg, for their patience and understanding during the preparation of the manuscript.

TABLE OF CONTENTS

ACKNOWLEDGEMENTS	iv
LIST OF TABLES	vi
LIST OF ILLUSTRATIONS	vii
ABSTRACT	ix
Chapter	
I. INTRODUCTION	1
Development of Photographic Interpretation	1
Contemporary Research in Photo Interpretation	4
II. THEORETICAL CONSIDERATIONS OF MULTIBAND PHOTOGRAPHY	6
Spectral Properties of Surface Matter	6
Multiband Recording of Spectral Properties	10
Relationship of Tone Signature and Spectral Properties	19
III. METHODOLOGY FOR DETERMINING TONE SIGNATURES	22
Density Tone Signature from Separation Negatives	22
Density Tone Signature from Ektachrome and Infrared Ektachrome Color Films	27
Comparison of Density Tone Signature from Separation Positives, Ektachrome and Infrared Ektachrome	27
Density Slope Tone Signature	31
IV. SUMMARY AND CONCLUSIONS	47
Suggestions for Further Research	48
APPENDIX I	49
APPENDIX II	50
BIBLIOGRAPHY	51

LIST OF TABLES

Table	Page
1. Separation Positive Density Readings	26
2. Density Tone Signature from Separation Positives	27
3. Ektachrome Density Readings.	29
4. Infrared Ektachrome Density Readings	30
5. Density Tone Signature from Ektachrome Film	30
6. Density Tone Signature from Infrared Ektachrome Film	31
7. Relative Density Tone Signature.	31
8. Density Slope from Separation Positives	42
9. Density Slope from Ektachrome Film	43
10. Density Slope from Infrared Ektachrome Film	44
11. Density Slope Tone Signature from Separation Positives	44
12. Density Slope Tone Signature from Ektachrome Film	45
13. Density Slope Tone Signature from Infrared Ektachrome Film	45
14. Chi-Square for Density Slope Determinations	46
15. Theoretical Positive Densities from Observed Negative Densities	49

LIST OF ILLUSTRATIONS

Figure	Page
1. The Electromagnetic Spectrum	7
2. Spectral Reflectance Curves of Selected Terrestrial Objects . .	11
3. Extraterrestrial Solar Radiation	13
4. Kodak Plus-X Panchromatic Film Sensitivity Curve	14
5. Kodak Infrared Black and White Film Sensitivity Curve	15
6. Kodak Ektachrome Spectral Sensitivity Curve	16
7. Kodak Infrared Ektachrome Spectral Sensitivity Curve	16
8. Normal Incidence Solar Radiation at the Earth's Surface	17
9. Transmission-Absorption Characteristics of Kodak Wratten Filters	18
10. Separation Negative Prints	24
11. The Ideal Negative Curve	25
12. Separation Negative Characteristic Curve	25
13. Ektachrome Print	28
14. Infrared Ektachrome Print	28
15. Density Versus Wave Length for Coniferous Trees on Separation Positives	33
16. Density Versus Wave Length for Deciduous Trees on Separation Positives	34
17. Density Versus Wave Length for Grass on Separation Positives . .	35
18. Density Versus Wave Length for Coniferous Trees on Ektachrome Film	36
19. Density Versus Wave Length for Deciduous Trees on Ektachrome Film	37
20. Density Versus Wave Length for Grass on Ektachrome Films	38

21.	Density Versus Wave Length for Coniferous Trees on Infrared Ektachrome Film	39
22.	Density Versus Wave Length for Deciduous Trees on Infrared Ektachrome Film	40
23.	Density Versus Wave Length for Grass on Infrared Ektachrome Film	41

ABSTRACT

Densitometric analysis of separation negatives, Ektachrome and Infrared Ektachrome film was performed to determine the tone signature from the films and to compare the respective tone signatures for reliability and use.

Three types of vegetation, coniferous and deciduous trees and grass, were used as targets for all the photography in this study.

The analysis and comparison of data used in this investigation revealed that density fluctuations within a specific spectrum band of a particular target were too great to yield a reliable and identifiable tone signature.

Analysis of the data revealed that the density differences between adjacent spectral bands remain relatively constant for a given target. The densities were graphed against the wave length and slopes of the lines connecting adjacent densities determined.

Chi-Square contingency tests indicate that Ektachrome and Infrared Ektachrome density slopes are significantly dependant and that the separation positive density slopes are highly independant. Therefore, it appears from the data used in this investigation that only the Ektachrome and Infrared Ektachrome density slope tone signatures can be used for identification of the targets utilized in the study.

It appears that the density slope method of tone signature determination compensates for error in exposure and developing procedure by eliminating the use of absolute density and relying on density differences between adjacent spectral bands.

10
CHAPTER I

3
INTRODUCTION

23 The use of tone signature, for identification purposes, is one of 10
the newer principles in the evolving field of remote sensing. This par-
ticular study involves only one aspect of remote sensing, that which is
recognized as multiband photography.

Aerial Photography has become the major data gathering tool in
the mapping and cataloging of man's natural and cultural environment. The
prime interest in this endeavor is the identification of the imagery ob-
tained in these photographs. It is recognized that the specific reflec-
tance properties of surface features can be identified from the density
of their image as recorded by given film-filter combinations.¹ It is the
purpose of this study to use this method as a key to determine whether a
significant tone signature can be obtained by using color films which have
a fixed sensitivity to the wave lengths of the reflected energy that can
be recorded.

Development of Photographic Interpretation

It is thought that the first permanent photographic images were
made by a Frenchman, Joseph Necephare Niepce, in the year 1827.²

¹Robert N. Colwell, "Procurement of Aerial Photography," Manual of Photographic Interpretation (Washington, D.C.: American Society of Photogrammetry, 1960), p. 48.

²Paul E. Boucher, Fundamentals of Photography (Princeton, New Jersey: D. Van Nostrand Co., Inc., 1963), p. 3.

Photographic images had been recorded before this time but they deteriorated shortly after exposure and were more of a scientific curiosity rather than a scientific principle. Niepce died in 1833, but his work was carried on by his partner Louis Jacques Monde Daguerre and others, and the field of photography gradually evolved into an exacting science.

The first known aerial photograph was taken from a captive balloon in France in 1840 and in 1858 Gaspard Felix Tourmacion, a French photographer, used captive balloons to take photographs from an altitude of several hundred feet. Tourmacion used his imagery to make topographic maps of the earth near the village of Petit Bicetre. During the American Civil War General McClellan utilized photographs of Confederate positions at Richmond taken from captive balloons at an altitude of about 1400 feet to help gather information used in the formulation of his attack plans.

From the end of the Civil War to the beginning of World War I many different methods of carrying a camera aloft were explored. Among some of the methods tried were kites, pigeons and compressed air rockets. The first recorded photograph taken from an airplane was made on April 24, 1909 by Wilbur Wright.³

Aerial Photography of a practical nature dates from World War I. It was during this time that extensive use of airplanes as photographic platforms were introduced.⁴ The first camera, produced and designed exclusively for aerial photography, was developed by Lieutenant Colonel J. T. C. Moore Brabazon of the R.A.F. and Thorton Pickard of Great Britain,

³Robert S. Quackenbush, Jr., "Development of Photo Interpretation," Manual of Photographic Interpretation (Washington, D. C.: American Society of Photogrammetry, 1960), pp. 3-5.

⁴Ibid., p. 5.

and came into use at the end of 1915. Although the value of aerial photography and the need for trained photo interpreters had been demonstrated during the war, military interpretation virtually came to a standstill after 1918.

However, scientific and commercial use of aerial photography made many advances in the field between World War I and World War II. New camera and film developments paved the way for better and clearer photographic images. By 1940 hundreds of papers had been published in journals of archaeology, ecology, geology, pedology, forestry, engineering, and geography on photogrammetry and photo interpretation. Since 1930, many U.S. government agencies, including the Forest Service, Geological Survey and Adjustment Administration have used aerial photography extensively in the mapping of the United States and the cataloging of our natural resources.

The effect of World War II can hardly be overemphasized as a stimulus to aerial photography and image interpretation. Germany and Great Britain made extensive use of air photos in the early months of the war and by 1942 the United States Navy, Army Air Force and Ground Forces had established photographic interpretation schools.⁵ The training of large numbers of men in military interpretation is credited as being the greatest single contribution of World War II to photo interpretation.⁶ Thousands of professional people, geologists, engineers, foresters, geographers, soil scientists and others gained both training and practical experience in photo interpretation from their military involvement. These trained professionals, upon returning to their civilian occupations,

⁵Ibid., p. 8.

⁶Ibid., p. 12.

played an important part in demonstrating to the professional and academic world the value of aerial photography.

The lessons learned about aerial photography and air photo interpretation during World War II were not forgotten. The world's military establishments keep up a continuous research and development program and many of the advancements in aerial photography equipment are primarily results of military research.

Contemporary Research in Photo Interpretation

Since the early 1950's the emphasis has shifted somewhat from the development of new and improved cameras, films and photo procuring equipment to new methods of image taking and image analysis. Color photography has begun to be used extensively because of its relative ease of interpretation. One of the major reasons for the superiority of color film over black and white film is that it appears more like the original scene, with many of the subtle shadings of hues and saturations represented. People are accustomed to seeing and identifying objects not only by shape and form but also by color. Sorem, in Principles of Aerial Color Photography, concludes ". . . that the full advantages of color won't be realized until each photographer gains experience with it in his particular application and until photo interpreters are trained to exploit the wide potentialities of color photographs."⁷

Until the late 1950's remote reconnaissance had been primarily restricted to conventional panchromatic films and viewing methods. About this time researchers began experimenting with multiband photography.

⁷Allan L. Sorem, "Principles of Aerial Color Photography," Photogrammetric Engineering, XXXIII, No. 9 (1967), 1010.

Donald Orr, Multiband-color Photography, defines multiband photography as ". . . isolating the electromagnetic energy reflected from a surface in a number of given wave length bands and recording each spectral band separately on black and white film."⁸ The different reflectance properties of earth materials is then utilized in an identification procedure of these multiband images. Another line of current research is the construction of color images using additive color viewing techniques and multiband photographic images. By using different colored light and image combinations a false color image of a given scene can be constructed that will greatly enhance the contrast of a given object and its background. This makes the identification of the object easier and more accurate. Leaders in this line of research are Professor Edward F. Yost and Sandra Wenderoth of Long Island University, and they have participated in the development of both cameras and viewing equipment for additive aerial photography.⁹

⁸ Donald G. Orr, "Multiband-color Photography," Manual of Color Aerial Photography (Falls Church, Virginia: American Society of Photogrammetry, 1968), p. 441.

⁹ Sorem, "Principles of Aerial Color Photography," p. 1020.

CHAPTER II

THEORETICAL CONSIDERATIONS OF MULTIBAND PHOTOGRAPHY

Spectral Properties of Surface Matter

The energy relationships that are examined in the following discussion concern the energy of the electromagnetic spectrum. This spectrum is a classification, according to wave length or frequency, of all energy that moves at the constant velocity of light in a harmonic wave pattern. The major interest here is with the visible and near infrared portions of the electromagnetic spectrum which make up a very small part of the entire electromagnetic spectrum (Figure 1).

The early work of Max Planck established that energy of electromagnetic radiation is transferred in discrete units called quanta and that these quanta were the minimum energy units of the electromagnetic spectrum.¹⁰ A few years later Albert Einstein confirmed Planck's theories of quantum energy transfer and termed these energy units photons.¹¹ Therefore, the radiation of the electromagnetic spectrum is considered both as waves and as energy pulses or photons. A reasonable conclusion that can be made is that electromagnetic radiation is in "reality" a wave-like stream of photons.¹²

¹⁰Herbert A. Pohl, Quantum Mechanics for Science and Engineering (Englewood Cliffs, New Jersey: Prentice-Hall, Inc., 1967), p. 3.

¹¹Ibid., p. 5.

¹²Ibid., p. 18.

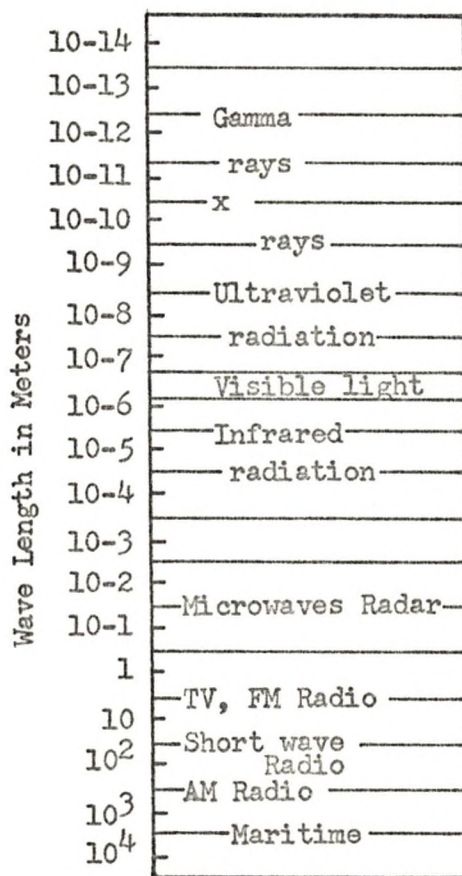

Fig. 1--The Electromagnetic Spectrum¹³

¹³George Shortley and Dudley Williams, Elements of Physics (Englewood Cliffs, N. J.: Prentice-Hall, Inc., 1961), p. 610.

In further discussion of the visible portion of the electromagnetic spectrum several characteristics of radiant energy of the spectrum must be kept in mind.

1. Electromagnetic waves do not interact among themselves.
2. Electromagnetic waves differ only in wave length, frequency and energy.
3. In the visible portion of the spectrum the three basic processes are emission, transmission and absorption.
4. In empty space the energy is propagated without limit, but in real situations propagation is through a media and reflects from or dissipates in matter.
5. The intensity of the radiation is the number of photons per unit time and area.¹⁴

Two conclusions that can be made from these basic characteristics are that energy changes of photons are due exclusively to interactions with matter, and that differences between separate wave lengths are differences in their interactions with matter.

Here it must be realized that all matter is a collection of particles held together by finite forces and that these particles are the fundamental building units of atoms and molecules. The dominant feature of these atoms and molecules is an electron cloud which surrounds an atomic nucleus. These electron clouds are in constant rapid motion and have a definite distribution in space and time around an equilibrium or mean position on both the molecular and atom scale. Therefore, the electron structures of atoms or molecules of which a given kind of matter is composed are different from those of the atoms or molecules comprising some

¹⁴Report of Subcommittee I on photo interpretation, American Society of Photogrammetry, "Basic Matter and Energy Relationships Involved in Remote Reconnaissance," Photogrammetric Engineering, XXIX, No. 5 (1963), 764.

other kind of matter.

Considering these characteristics of matter, the basic characteristics of electromagnetic energy and the physical law of mass and energy conservation, a number of interactions are possible when a photon of a given energy level strikes the boundary of solid matter. The energy can either be:

1. Transmitted--generated through the solid matter;
2. Absorbed--giving up its energy to the matter;
3. Emitted--or more commonly re-emitted by the matter at the same or different wave length;
4. Scattered--deflected to one side and ultimately lost to absorption or further scatter; or
5. Reflected--returned unchanged to the medium.¹⁵

These possible interactions are the basis for one of the basic principles of multispectral remote sensing. The transmission, absorption, emission, scattering or reflectance of electromagnetic energy by a particular kind of matter is selective with respect to wave length and is specific for that kind of matter, depending to a great degree upon its atomic and molecular structure.¹⁶ In principle and in view of this fact, any collection of matter which makes up a target can be identified if a wave length plot, a spectrozonal series of images or any record which is detailed enough to show its spectral properties is available.

In 1953 the National Research Council of Canada translated a study from the Russian by E. L. Krinov, Spectral Reflectance Properties of

¹⁵Robert N. Colwell, "Uses and Limitations of Multispectral Remote Sensing," Proceedings of the Fourth Symposium on Remote Sensing (Rev. ed., Ann Arbor: Willow Run Laboratories, The Institute of Science and Technology, 1966), p. 73.

¹⁶Ibid.

Natural Formations, which presents 370 reflectance curves for surface phenomenon.¹⁷ Krinov used spectrographs, both in the laboratory and in the field, to measure the exact reflectance properties of a large number of surface objects. When these reflectance curves are examined it can be seen that different kinds of surface objects do in fact give very definite identifiable and unique reflectance curves (Figure 2). In 1959 Robert Colwell used spectrograph plots of light reflectance of four different surface objects to predict the tone of these same objects on photographic positive prints.¹⁸ Colwell's predictions were true and he presents a definitive tone sequence for these objects using two bands of the spectrum.¹⁹

Multiband Recording of Spectral Properties

To operate a remote sensing system effectively in any specified wave length range of the electromagnetic spectrum, the following factors must be present and accounted for:

1. An energy source that will provide photons which have the proper wave length;
2. A target (i.e., a collection of matter) which will interact with the photons in this range;
3. An energy detector that is sensitive to photons in this range;
4. A propagating medium or void between detector and target that will transmit photons in given wave length range; and

¹⁷E. L. Krinov, Spectral Reflectance Properties of Natural Formations, trans. by G. Belkor (Ottawa: National Research Council of Canada, Technical Translation 439, 1953).

¹⁸Colwell, "Procurement of Aerial Photography," p. 48.

¹⁹Robert N. Colwell, "Some Practical Applications of Multiband Spectral Reconnaissance," American Scientist, XLIX, No. 9 (1961), 10.

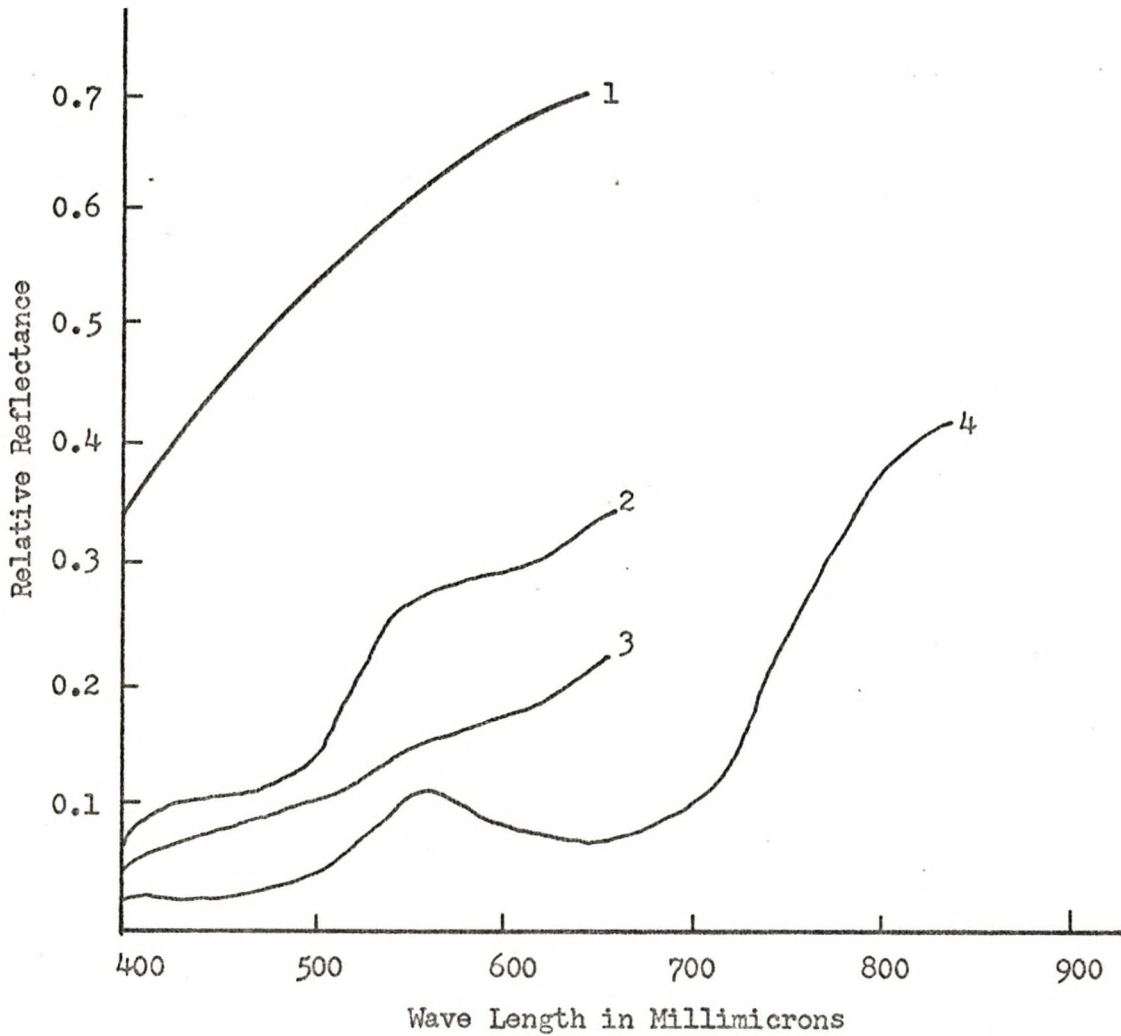

Fig. 2--Spectral Reflectance Curves of Selected Terrestrial Objects²⁰

1. Bare soil; 2. Oak forest; 3. Fir forest; 4. Barley

²⁰Krinov, Spectral Reflectance Properties, pp. 114, 191, 232.

5. An energy filter which will transmit the specified wave length photons and screen out the unwanted photon to which the detector may be sensitive.²¹

The investigator's research topic, A Tone Signature Analysis of Multispectral Photography, is a densitometric analysis of remote sensing imagery. An examination of the above factors necessitates consideration of the remote sensing equipment and specific wave length bands. The equipment consists of normal photographic cameras, films and filters and the wave length range is the visible and near infrared portions of the electromagnetic spectrum (400 to 900 millimicrons). The energy source utilized is the sun which radiates in all wave lengths of the electromagnetic spectrum.²² Examination of the sun's radiation curve (Figure 3) indicates the wave length of maximum emission is about 500 millimicrons. This makes it a good energy source for the visible and near infrared wave lengths, 400-900 millimicrons.

The targets used are surface objects which are subject to definitive reflectance interactance with the energy in the wave lengths which encompass the visible and near infrared portions of the electromagnetic spectrum.

The energy detectors used are Kodak Plus-X panchromatic film, Kodak black and white Infrared film, Kodak Ektachrome and Infrared Ektachrome color film. The sensitivity curve for Plus-X panchromatic film (Figure 4) indicates that it is sensitive to a wave length range of 400 to 700 millimicrons which is approximately the extent of the visible portion

²¹Report of Subcommittee I on photo interpretation, "Basic Matter and Energy Relationships," p. 797.

²²Stuart J. Inglis, Planets, Stars and Galaxies (New York: John Wiley & Sons, Inc., 1961), p. 206.

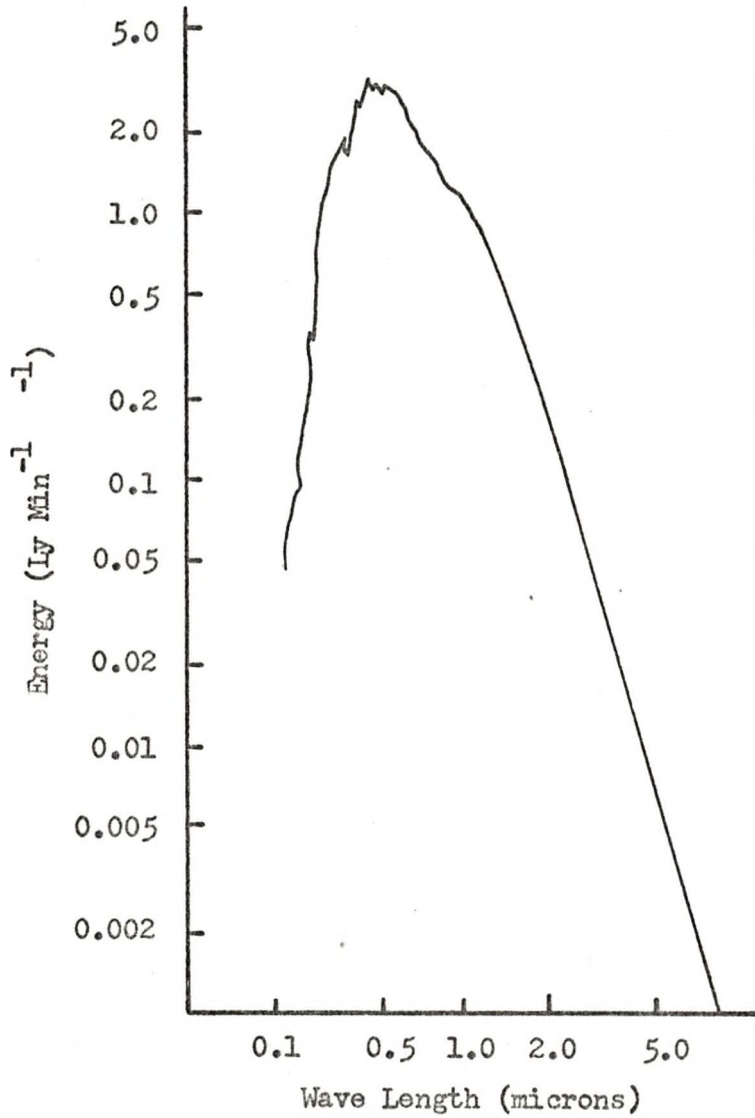

Fig. 3--Extraterrestrial Solar Radiation²³

²³William D. Sellers, Physical Climatology (Chicago: University of Chicago Press, 1965), p. 20.

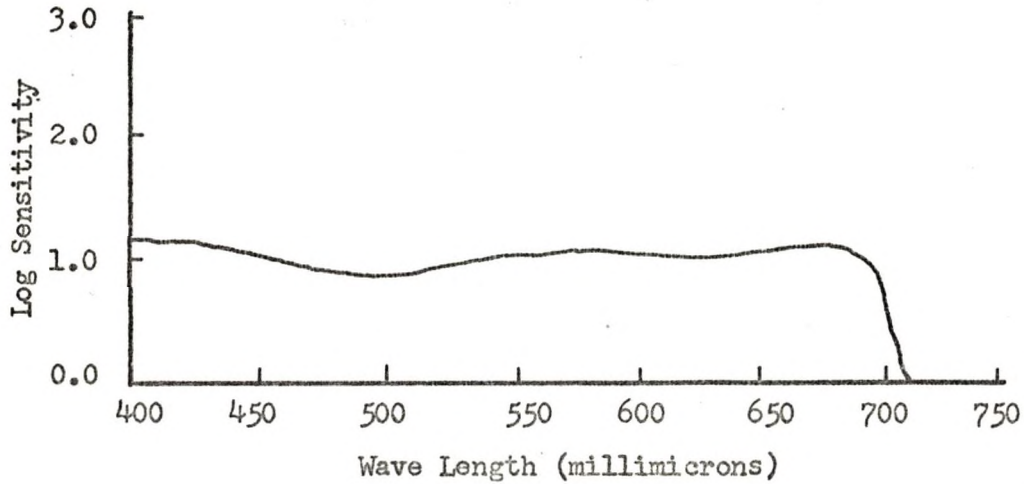

Fig. 4--Kodak Plus-X Panchromatic Spectral Sensitivity Curve²⁴

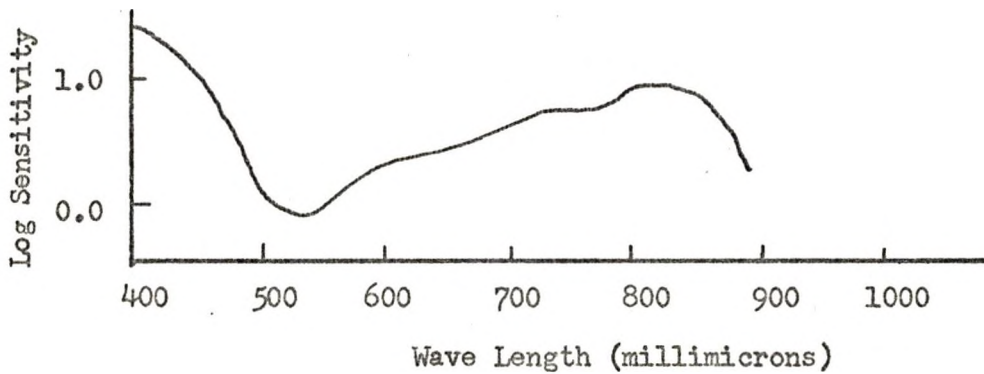

Fig. 5--Kodak Infrared Black and White Spectral Sensitivity Curve²⁵

²⁴Eastman Kodak, Data for Aerial Photography, Publication No. m-29 (Rochester, N.Y.: Eastman Kodak Co., 1968), p. 33.

²⁵Ibid., p. 56.

of the electromagnetic spectrum. Examination of Figure 5 reveals that Kodak Infrared film is sensitive to energy from 400 to approximately 900 millimicrons, which encompasses the near infrared region of the electromagnetic spectrum. These two films give complete coverage of the portion of the electromagnetic spectrum used in this study. Figures 6 and 7 are sensitivity curves for Ektachrome and Infrared Ektachrome film and examination reveals that these films also yield complete coverage of the wave length bands utilized in this study.

The propagating medium of the energy is the earth's atmosphere. Energy from the sun passes through a relative void and undergoes little change until it reaches the earth's atmosphere. The earth's atmosphere does have a definite effect on this incoming energy. Examination of Figure 8 reveals a "window" exists for the wave length range that is used in this investigation. This means the atmosphere transmits energy in the bands, 400 to 900 millimicrons, that is used in the photographic recording of this project.

Filters are used to screen out the unwanted energy and transmit energy in the desired wave lengths. Three overlapping transmission filters that completely cover the visible portion of the spectrum are used in conjunction with the Plus-X film. The filters, Wratten numbers 25 (red), 47B (blue), and 58 (green), when used separately yield a recording of the energy that is being reflected from the target in the respective wave lengths that are transmitted by each filter. Figure 9 is a graphic representation of the transmission-absorption characteristics of these particular filters.

A further consideration in using these three filters is that they

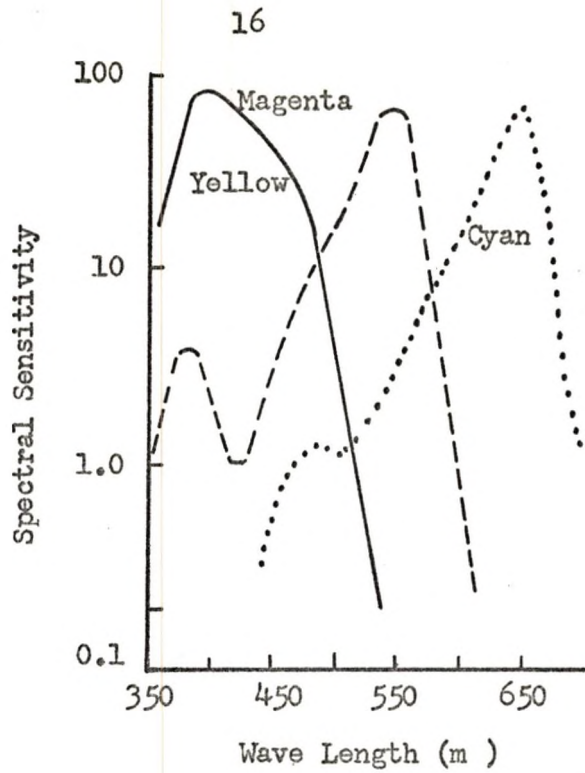

Fig. 6--Kodak Ektachrome Spectral Sensitivity Curve²⁶

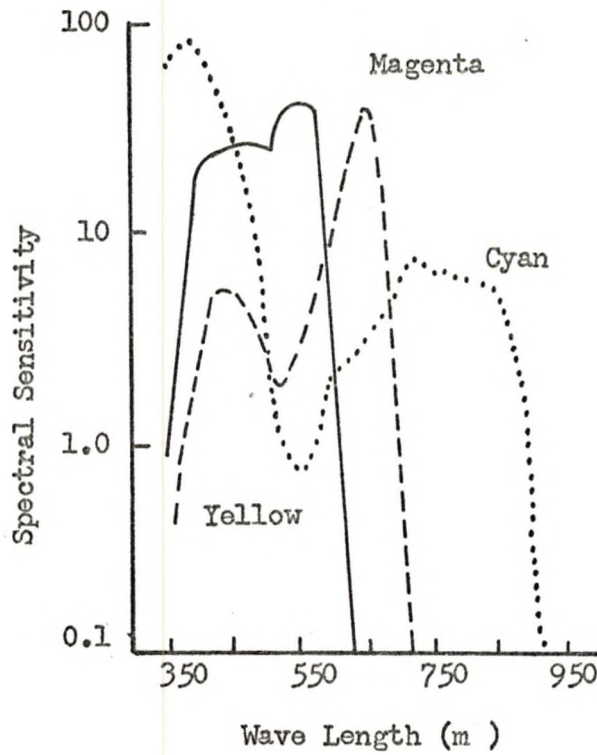

Fig. 7--Kodak Ektachrome Infrared Spectral Sensitivity Curve²⁷

²⁶Orr, "Multiband Color Photography," p. 449.

²⁷Ibid.

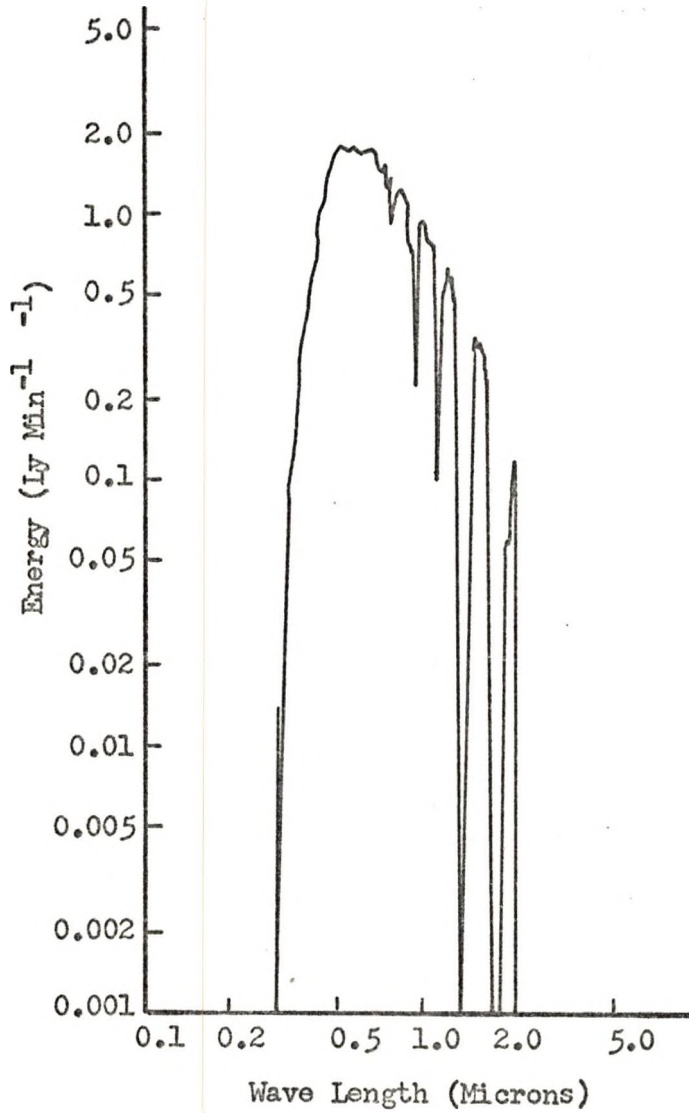

Fig. 8--Normal Incidence Solar Radiation at the Earth's Surface²⁸

²⁸Sellers, Physical Climatology, p. 20.

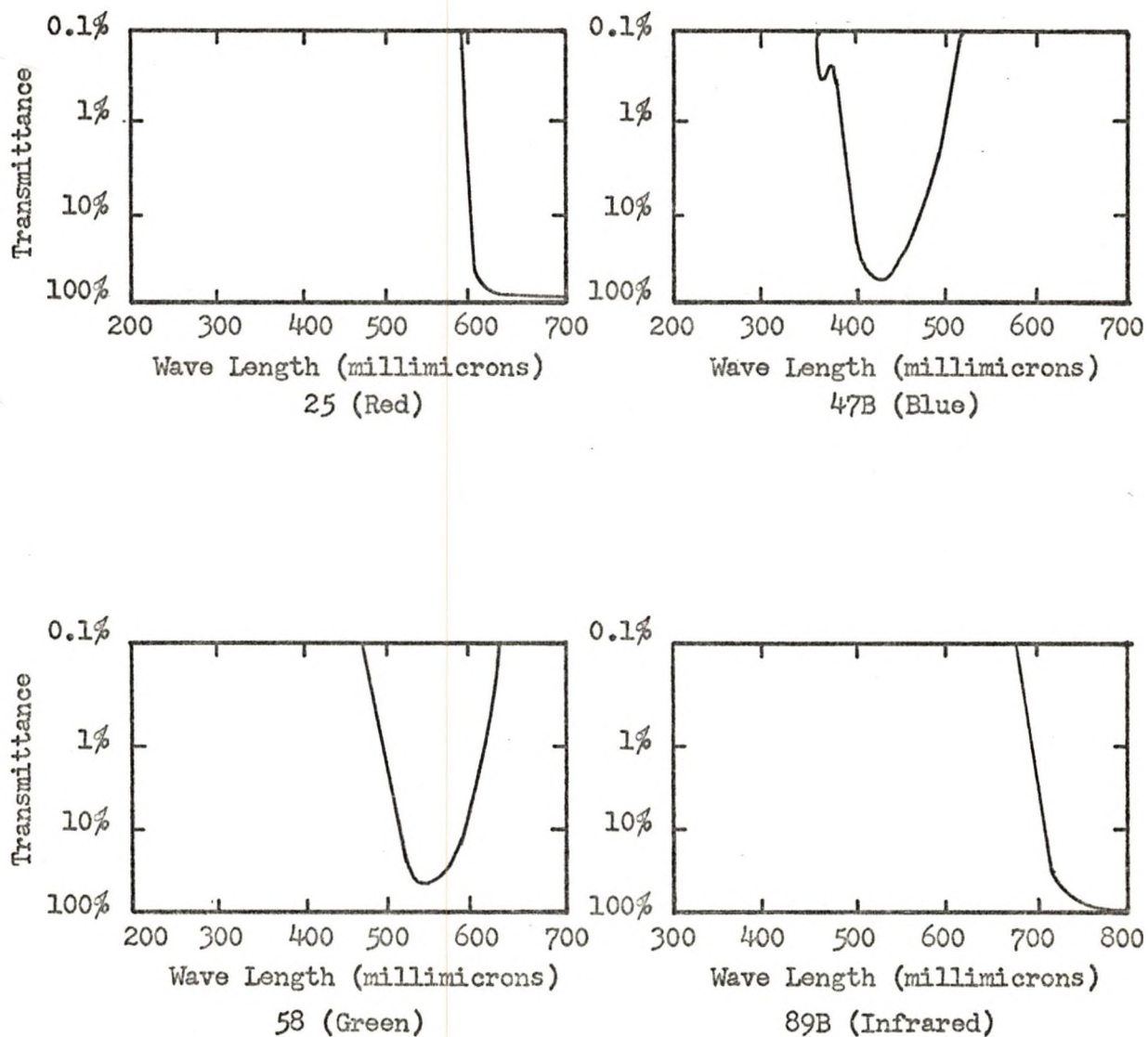

Fig. 9--Transmission-Absorption Characteristics
of Wratten Filters²⁹

²⁹Kodak Wratten Filters, Publication No. B-3 (Rochester, N.Y.: Eastman Kodak Co.), pp. 31, 39, 43, 50.

approximate the spectral sensitivity of Kodak Ektachrome color film.³⁰

The tone signature determined from images formed through these three filters was compared to the tone signature from Ektachrome film.

A fourth filter, Wratten number 89B (infrared) is used in conjunction with Kodak infrared black and white film. The characteristic transmission-absorption curve (Figure 9) for the Wratten 89B filter indicates no visible transmission in the electromagnetic spectrum, thus allowing for a record on film of reflected energy in the near infrared only. This filter used in conjunction with filters 58 and 25 approximate the spectral sensitivity of Kodak infrared Ektachrome color film.³¹ The tone signature read from images formed through this series of filters is used as a truthing device in testing the expected tone signatures from infrared Ektachrome positive transparencies.

Relationship of Tone Signature and Spectral Properties

In black and white photography distinctions between colored hues are lost and objects are viewed as tones of gray. Tone is a term frequently used in photo interpretation and ". . . represents the relative intensity of photons impinging upon a silver halide plate, in the visible or near visible portions of the spectrum as reflected by objects viewed by the camera."³²

In general, photo interpretation studies or exercises, tonal

³⁰Orr, "Multiband-color Photography," p. 444.

³¹Ibid.

³²Roger M. Hoffer, Roger A. Holmes, and J. Ralph Shay, "Vegetative, Soil and Photographic Factors Affecting Tone in Agricultural Remote Multi-spectral Sensing," Proceedings of the Fourth Symposium on Remote Sensing of Environment (Rev. ed.; Ann Arbor: Willow Run Laboratories, The Institute of Science and Technology, The University of Michigan, 1966), 115.

differences are visual comparisons of the different shades of gray existing on the photograph. The tones referred to in the analysis of photographs in this study are measured densities of the free metallic silver which constitutes the image that is viewed on a photographic material. Under a given set of conditions the reflected energy from a specific object is fixed and thus the densities resulting from this energy striking a photographic film will be fixed. The term tone signature is a reference to these distinctive individual densities that result from the different intensities of reflected energy that strike the film.

The densities of the image were measured with a Kodak Transmission-Reflection Densitometer. This instrument measures the optical density or light-stopping power of the silver deposits forming the image. The procedure by which the image is derived is called the photographic process. This process takes place in the following distinct steps of exposure, development and fixation:

Exposure.--Light is directed to act upon the light sensitive emulsion of the film to form a latent image. This process proceeds in three steps.

1. A photon is absorbed by the silver halide-gelatin film emulsion which raises the energy state of an electron in the silver halide crystals.
2. The electron passes from the silver halide crystal to a silver sulfide "speck" associated with the crystal.
3. The electron then attracts and unites with a cation of silver. As additional photons are absorbed, the speck continues to grow.

Development.--Reducing agents are added to the film providing additional electrons to the silver halide crystal and reduce all the silver halide to opaque silver.

Fixation.--Although an image of metallic silver has formed in a developed film, unchanged silver halide is still present and still may be affected by absorbed photons. Removal of the residual, insoluble silver halide is accomplished by the addition of chemicals (thiosulfate) that react with the silver halide to form a soluble

silver thiosulfate. The film is then washed in water to remove the unused silver and other development by-products.³³

The observed film densities which constitute the tone signature are not measurements of total energy that is reflected from a given target. The densities are indices of the relative reflected energy between an object and its background of surrounding objects. The relationship of total reflected energy to the photographically recorded reflected energy depends on many factors including atmospheric scattering, camera construction and optics, film sensitivity, film transmission, wave length of energy, exposure and development of film, solar altitude and the sun's angle of incidence. When all of the above factors are held constant photographic density differences can then be attributed to differences in the amount of reflected energy coming from the target.

In view of the photographic process, the many factors affecting incoming energy and the recording of reflected energy it must be realized that the density readings used in assigning tone signatures are not recordings of the total reflected energy from surface objects. The differences in photographic image density do, however, have a direct relationship with the relative differences in total reflected energy from the target and thus can be used in the separation of an object from its background. These density differences, for purposes of identification, are referred to as tone signatures.

³³J. Ronald Eyton, "Multispectral Photography" (unpublished paper, University of North Dakota, 1968), p. 8.

CHAPTER III

DENSITY TONE SIGNATURE FROM SEPARATION NEGATIVES

The procedure of producing separation negatives for densitometric analysis requires that density differences come from the different reflective properties of the target and not from differences in the film-filter, exposure or development combinations. The Eastman Kodak technique of film standardization was used in this study.³⁴ This technique utilizes a standard Kodak gray scale as a test target and the film to be standardized is subjected to a series of exposures with each filter used in producing the separation negatives. The film is developed and the density of the target on the film is graphed against the original density of the gray scale target (Density Log Exposure Curve here is referred to as D Log E curve). Theoretically when a film is balanced the D Log E curves of each film-filter combination can be superimposed. When this occurs it is assured that equal amounts of energy are striking the film after passing through the different filters. In practice, the exact matching of curves for the different filters is almost impossible to attain, thus the D Log E curves for the four filters that most closely match are used.

The gamma of a photograph is rise over run on the D Log E curve and is controlled by development. Kodak instructions for separation negatives recommend a gamma of 0.7 and use of the straight line portion of the

³⁴Eastman Kodak, Color Separation and Masking, Pamphlet No. E-64 (Rochester, N. Y.: Eastman Kodak Co., 1959).

D Log E curve.³⁵ Kodak also recommends a difference between highest and lowest density of 1.2. These recommendations are followed in this investigation. When the film is balanced in this manner, the change in the densities of different objects on a film image can be attributed to differences in reflective properties of the objects themselves.

Three classes of vegetation, coniferous and deciduous trees and grass, were chosen as targets for this investigation. If a significant difference in tone signature can be shown for these three subjects which are relatively close in reflectance properties then the procedure should be valid for other features which are more varied in reflectance properties.

Six sets of separation negatives were exposed using the exposure and development times from the standardization procedure. Figure 10 illustrates a sample set of separation negatives. The densities of the three study subjects are values read from the separation negative using a Kodak Transmission-Reflection densitometer.

Later in the study the tone signatures from the separation negatives are compared to the tone signatures from the Ektachrome and Infrared Ektachrome positive transparencies. Therefore, densities from the separation negatives must be changed to theoretical separation positives of the same targets used in producing the separation negatives. Analysis of Figure 11 shows that the D Log E curve of a positive image is a mirror image of the D Log E curve of the negative. Applying this principle to the present study, the density of the negative becomes the density of the original and the theoretical positive densities can be read directly from the Log E (neg) scale of the negative characteristic curve. The average slope

³⁵Kodak, Color Separation, p. 12.



Wratten 47B (blue)



Wratten 58 (green)



Wratten 25 (red)



Wratten 89B (infrared)

Fig. 10--Separation Negative Prints

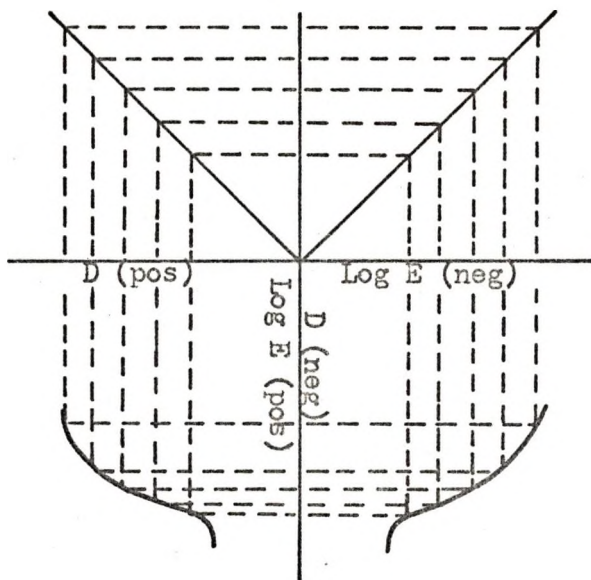

Fig. 11--The ideal negative curve.³⁶

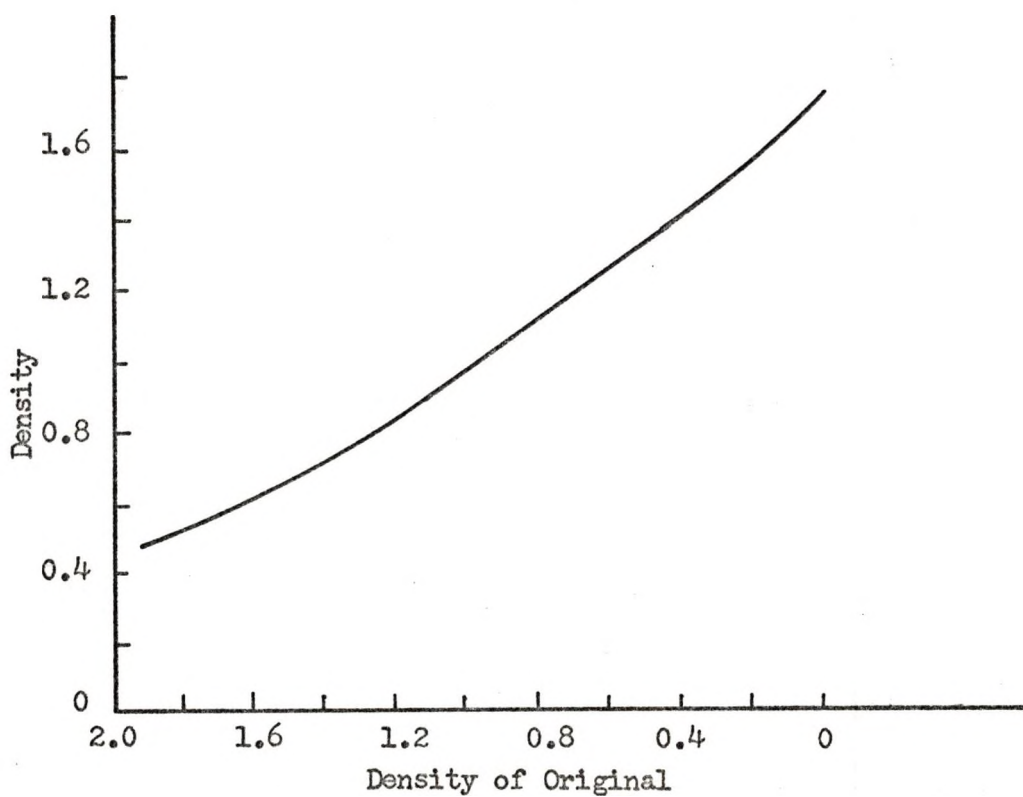

Fig. 12--Separation Negative Characteristic Curve.

³⁶Baines, H. The Science of Photography (New York: John Wiley & Sons, Inc., 1960), p. 238.

of the characteristic curve, Figure 12, for the separation negatives was calculated. Using the slope intercept equation for the line the theoretical positive densities were determined, Appendix I.

Table 1 presents the separation positive densities for the examples of the three target classes used. The density tone signature is

TABLE 1
SEPARATION POSITIVE DENSITY READINGS

Blue	Green	Red	Infrared
Coniferous Trees			
1.52	1.36	1.50	0.42
1.79	1.70	1.85	0.28
1.82	1.72	1.86	0.31
1.69	1.26	1.49	0.42
1.51	1.08	1.59	0.22
Deciduous Trees			
1.36	1.05	1.19	0.06
1.94	1.42	1.49	0.19
1.19	0.86	1.08	0.34
1.57	1.00	1.14	0.37
1.74	1.57	1.65	0.28
Grass			
1.42	1.08	1.22	0.09
1.28	0.68	0.94	0.17
1.33	0.91	1.05	0.25
1.42	0.91	1.05	0.37
1.19	0.80	0.97	0.28

derived by averaging the densities in each spectral band of the different target classes. Table 2 is a presentation of the density tone signature derived from each class of vegetation target.

TABLE 2

DENSITY TONE SIGNATURE FROM SEPARATION POSITIVES

Subject	Blue	Green	Red	Infrared
Coniferous Trees	1.66	1.42	1.65	0.33
Deciduous Trees	1.56	1.16	1.31	0.25
Grass	1.33	0.88	1.04	0.23

Density Tone Signature from Ektachrome and Infrared
Ektachrome Color Film

The densities of the targets in the specified wave length bands are read from the color films by using filters in the densitometer. The same targets employed in the exposure of the separation negatives were used to expose the color films. Figures 13 and 14 illustrate examples of the Ektachrome and Infrared Ektachrome photography used in this study. Table 3 lists the densities from Ektachrome film and Table 4 the densities from the Infrared Ektachrome film. Density tone signature for the color films, Table 5 and Table 6, were determined in the same manner as the density tone signature for the separation negatives.

Comparison of Density Tone Signature from Separation
Positives, Ektachrome and Infrared Ektachrome

Visual inspection of the three sets of density tone signature indicates that a relatively wide difference occurs in at least one band and in most instances in two bands for all three sets of tone signatures. Therefore, a relative tone signature table was calculated for each set of tone signatures. The difference between the highest and lowest density of a given set was divided into three equal parts and designated dark (D), medium (M) and light (L), ranging from high density to low



Fig. 13--Ektachrome Transparency Print

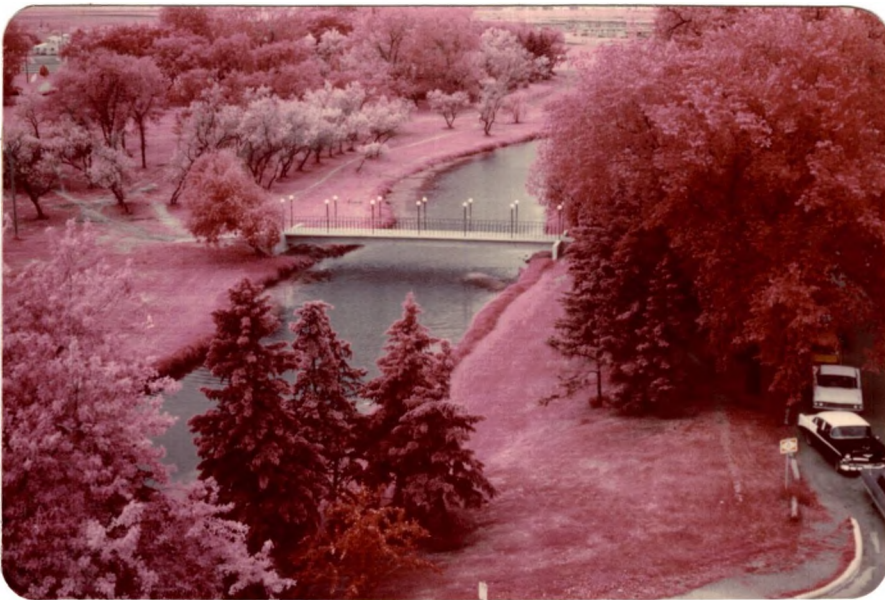

Fig. 14--Infrared Ektachrome Transparency Print

TABLE 3

EKTACHROME DENSITY READINGS

Blue	Green	Red
Coniferous Trees		
1.10	1.25	1.55
0.85	0.95	1.37
0.65	0.72	1.12
0.44	0.55	0.95
0.75	0.85	1.20
Deciduous Trees		
0.85	0.90	1.30
0.60	0.70	1.10
0.71	0.75	1.20
0.25	0.30	0.55
0.74	0.82	1.20
Grass		
0.74	0.65	0.98
0.56	0.50	0.84
0.92	0.82	1.25
0.58	0.44	0.80
0.68	0.60	0.95

density respectively. Inspection of Table 7 supports the conclusion that at least one band in each tone signature is relatively different from the remaining two tone signatures.

The Infrared Ektachrome tone signature appears to have the most distinctive difference in both actual density tone signature and the relative tone signature. The Ektachrome and separation positive tone signatures appear to have about equal differences in both actual and relative density. However, the separation positive tone signatures appear to be more distinctive than the Ektachrome tone signatures because the separation positives contain four spectral bands compared to the Ektachrome's three bands.

TABLE 4

INFRARED EKTACHROME DENSITY READING

Green	Red	Infrared
Coniferous Trees		
0.50	0.70	0.40
1.35	1.55	1.31
0.90	1.10	0.85
0.48	0.71	0.35
0.20	0.35	0.12
Deciduous Trees		
0.32	0.57	0.18
0.85	1.45	0.50
0.85	1.45	0.57
0.56	1.06	0.33
0.47	0.85	0.28
Grass		
0.32	0.55	0.32
0.93	1.21	0.98
0.14	0.35	0.20
0.17	0.37	0.20
0.30	0.50	0.30

TABLE 5

DENSITY TONE SIGNATURE FROM EKTACHROME FILM

Subject	Blue	Green	Red
Coniferous Trees	0.76	0.86	1.23
Deciduous Trees	0.63	0.69	1.07
Grass	0.70	0.60	0.96

Use of Infrared Ektachrome for tone signature determination has advantages compared to separation positives. The separation positive film must be standardized or balanced which is a time-consuming and difficult process. Four filters and two films must be used for separation positives

TABLE 6

DENSITY TONE SIGNATURE FROM INFRARED EKTACHROME FILM

Subject	Green	Red	Infrared
Coniferous Trees	0.69	0.88	0.61
Deciduous Trees	0.61	1.07	0.37
Grass	0.37	0.60	0.40

TABLE 7

RELATIVE DENSITY TONE SIGNATURE

Subject	Blue	Green	Red	Infrared
Separation Positives				
Coniferous Trees	D	D	D	L
Deciduous Trees	D	M	D	L
Grass	D	M	M	L
Ektachrome				
Coniferous Trees	M	M	D	
Deciduous Trees	L	L	D	
Grass	L	L	M	
Infrared Ektachrome				
Coniferous Trees		M	D	M
Deciduous Trees		L	D	L
Grass		L	L	L

compared to one film and one filter for Infrared Ektachrome. Factory standardization of the Infrared Ektachrome film tends to reduce errors in procedure and also reduces the amount of time and equipment needed for investigation.

Density Slope Tone Signature

Although the density tone signatures appear to be distinctive,

visual evaluation of densities for a given wave length and subject vary too greatly to be reliable. The author observed that relative density differences between bands of a given subject appear to remain constant from frame to frame for color films and from set to set for separation positives.

Graphs were constructed using density versus the dominant wave length transmission of the filters for the separation positives, Figures 15 through 17. The same parameters were used in graphing Ektachrome and Infrared Ektachrome since the filters approximate the sensitivity of the color films, Figures 18 through 23.

Inspection of the graphs indicates that distinct families of curves occur for each class of target and film type combination used in the investigation. In order to test this visual appearance the slopes of the lines connecting densities of adjacent spectral bands were calculated. Separation positives, which have four bands, have three slope readings, blue to green (B-G), green to red (G-R), and red to infrared (R-IR). Tables 8 through 10 illustrate the calculated slopes for the three films. In the same manner as density tone signature, the density slope tone signature was determined by averaging the slopes in the separate bands of each target-film combination. Tables 11 through 13 present a density slope tone signature for each target-film combination.

Analysis of the density slope tone signature of each target-film combination indicates that the average density slope tone signatures are more representative of the individual slopes that make up each average than are the density tone signature averages. The values of density slope for the separation positives appear to have too great a fluctuation for reliability. The Infrared Ektachrome readings appear to be the most

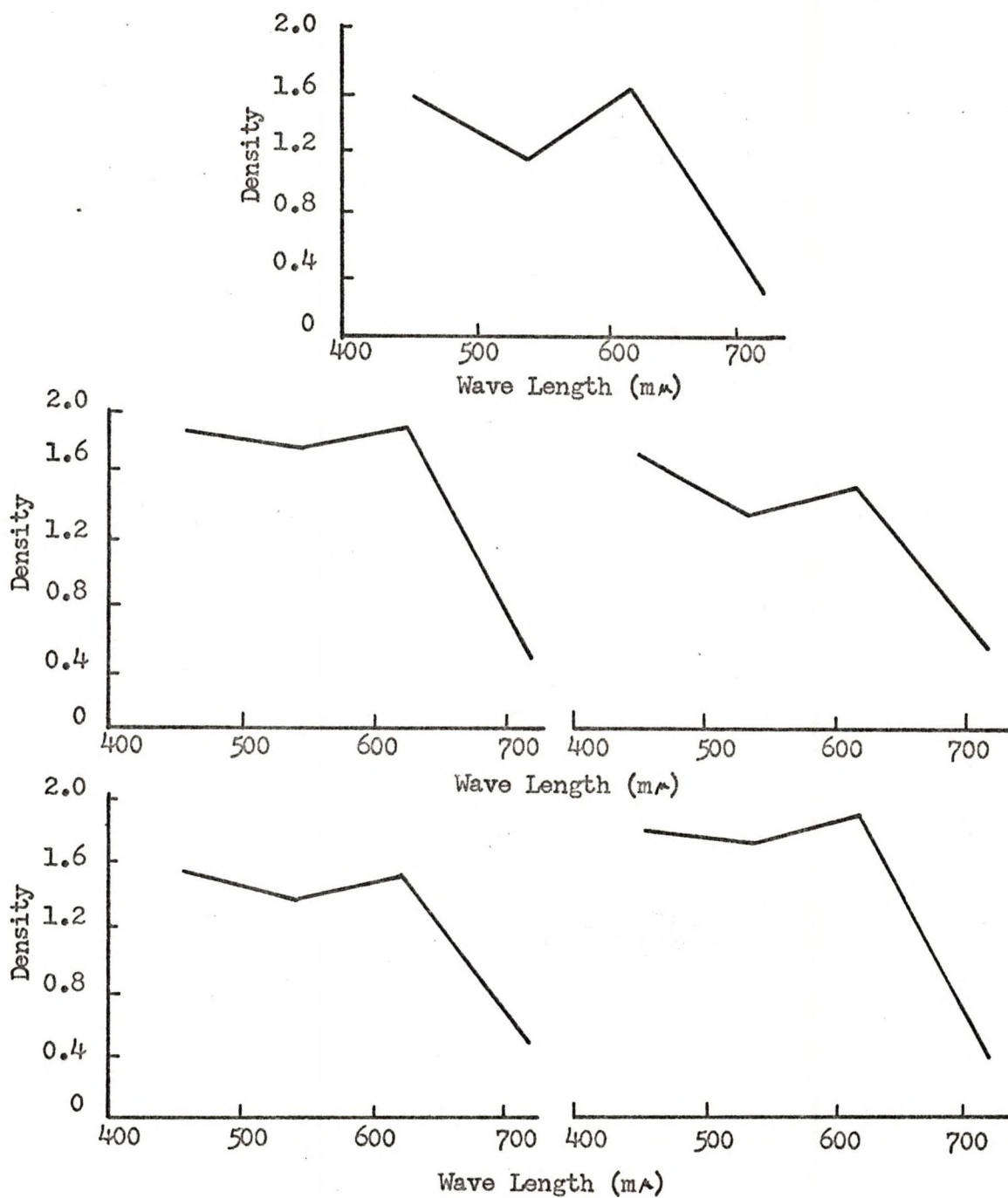

Fig. 15--Density versus Wave Length for Coniferous Trees on Separation Positives

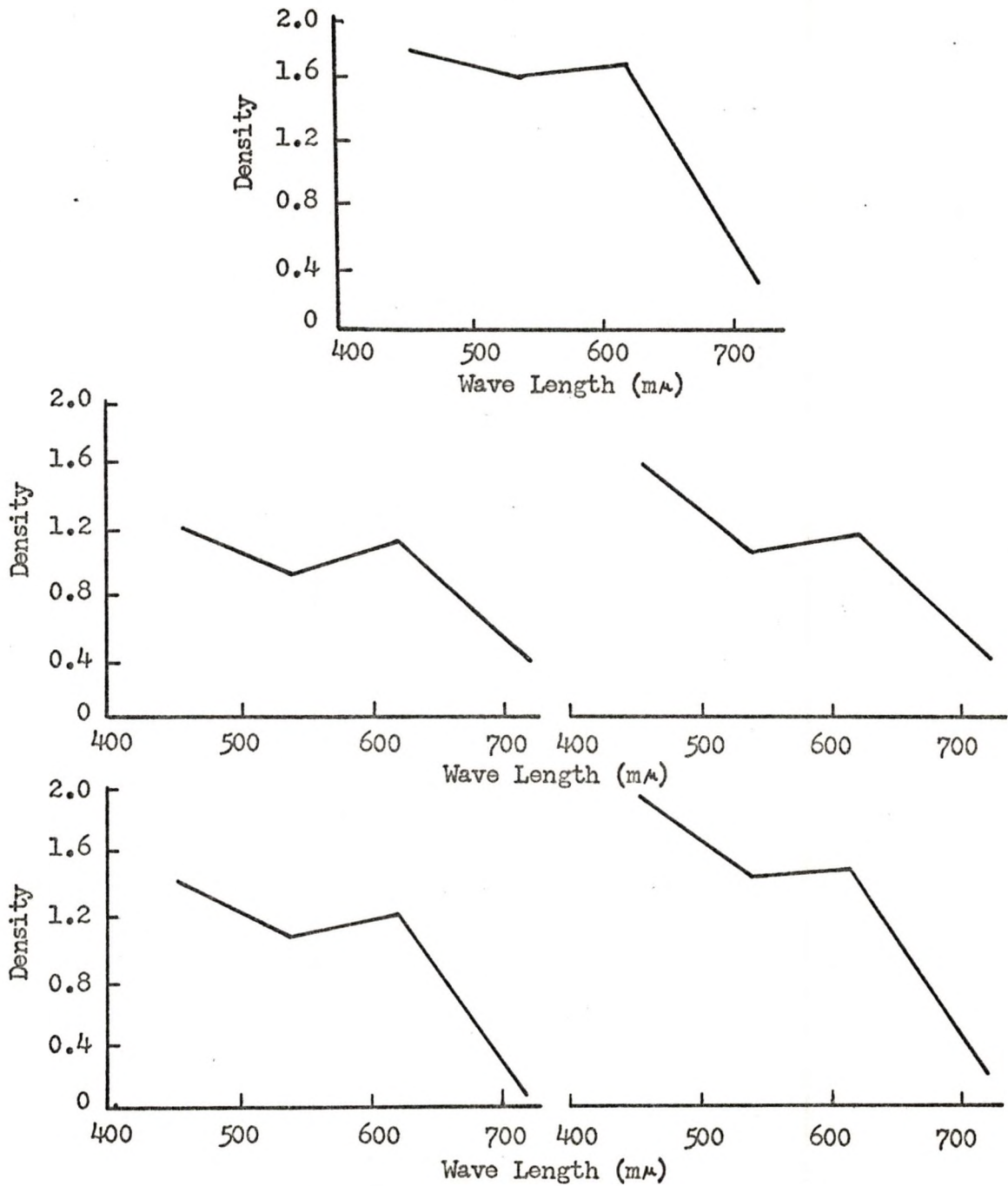

Fig. 16--Density versus Wave Length for Deciduous
Trees on Separation Positives

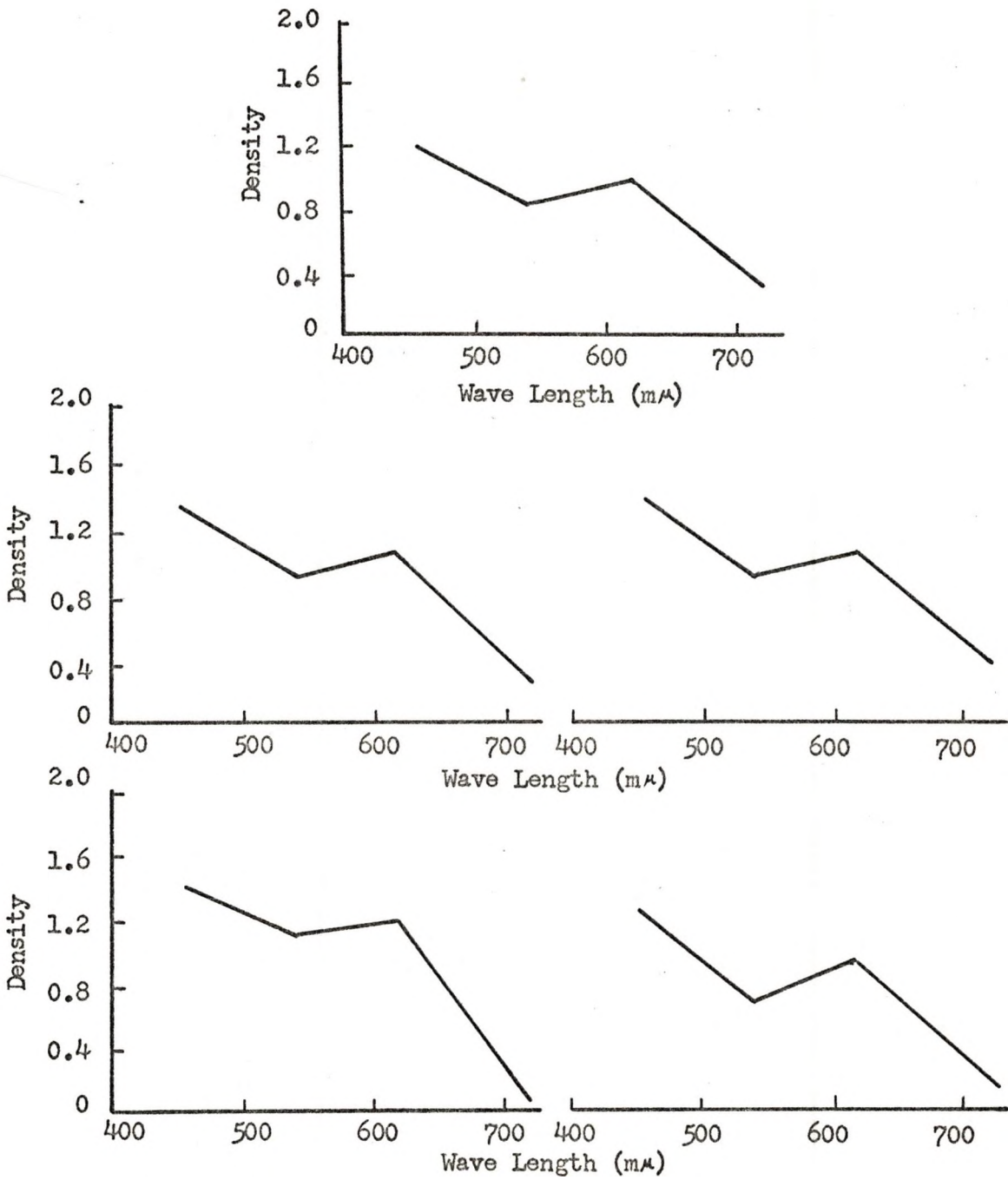

Fig. 17--Density versus Wave Length for Grass on Separation Positives

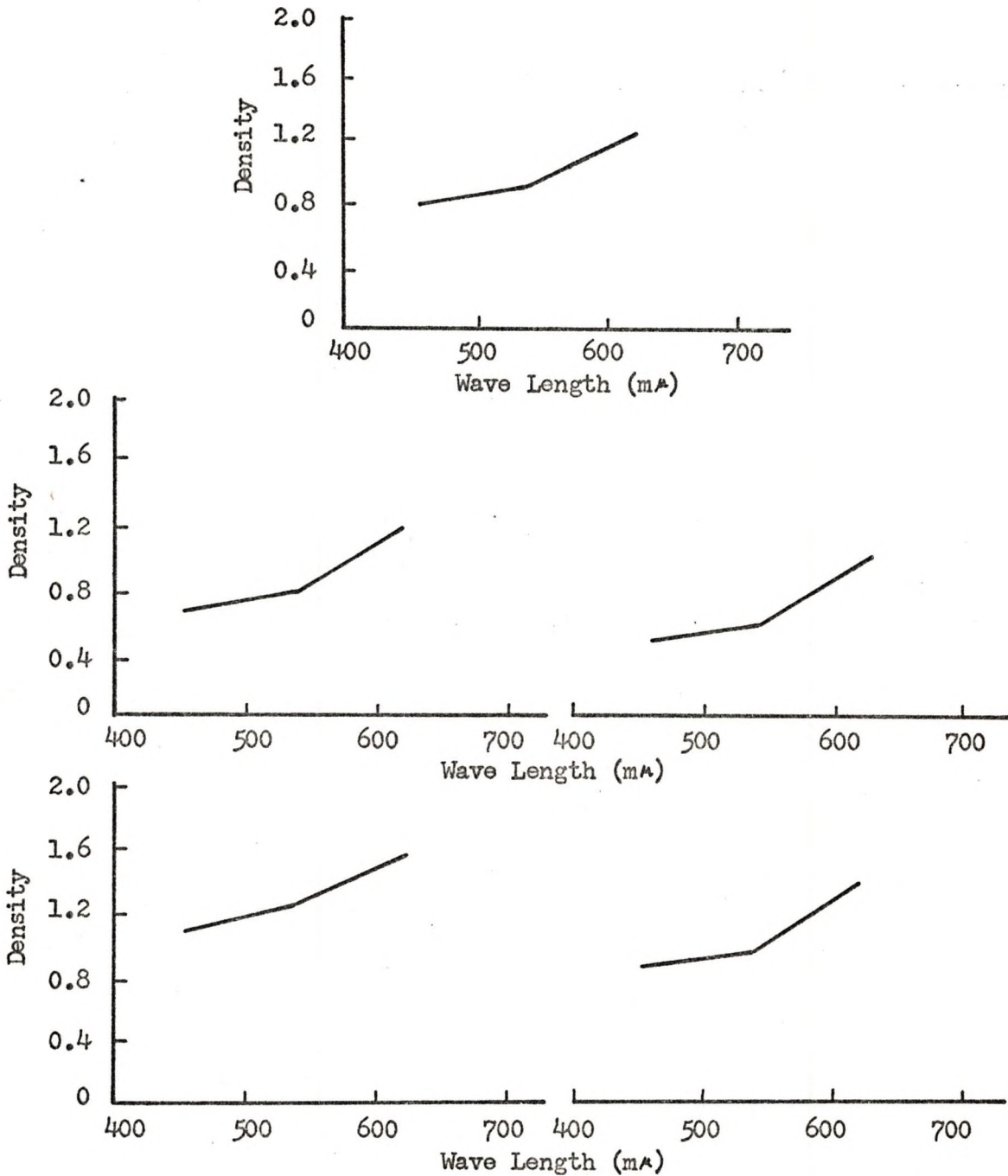

Fig. 18--Density versus Wave Length for Coniferous Trees on Ektachrome Film

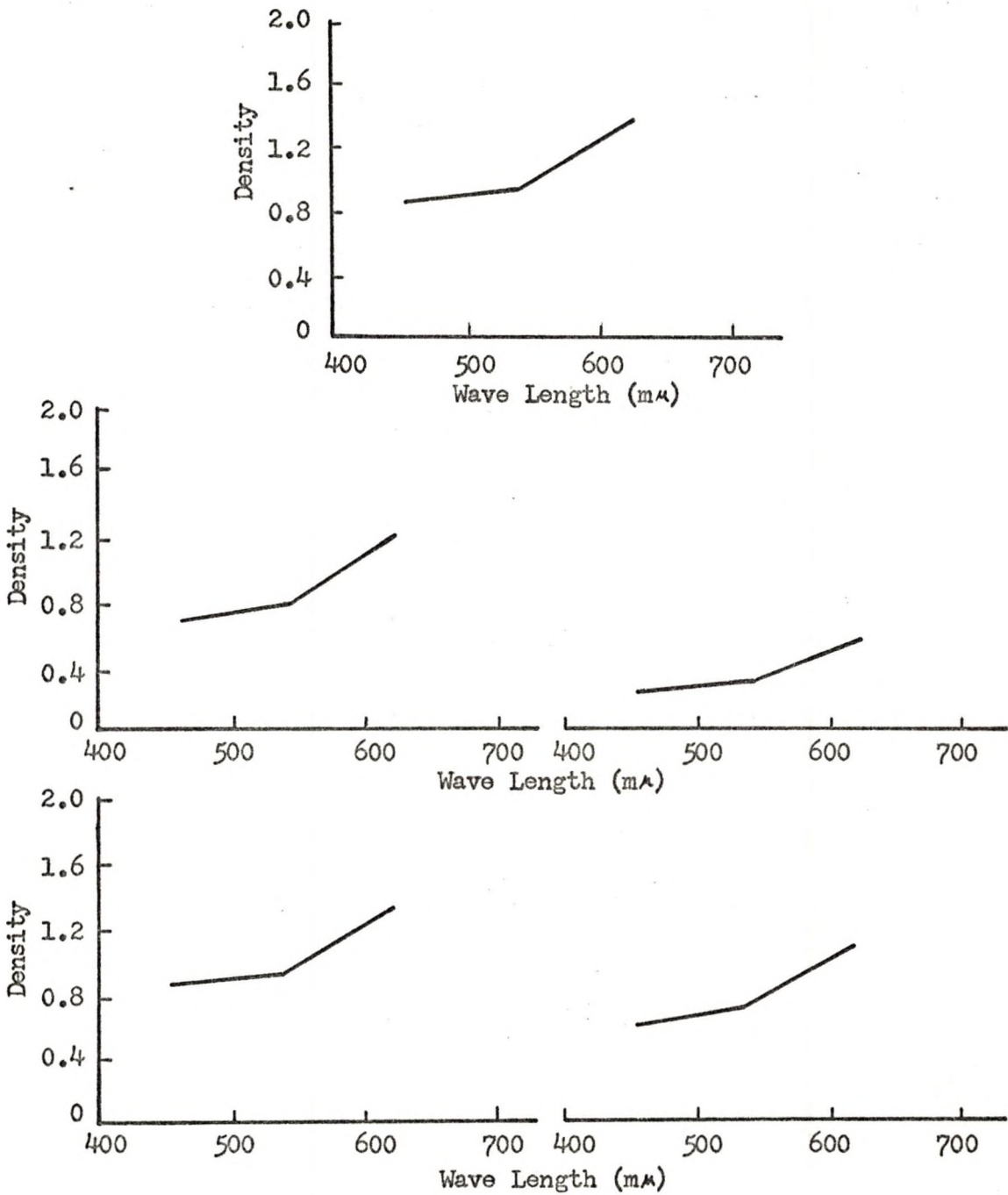

Fig. 19--Density versus Wave Length for Deciduous Trees on Ektachrome Film

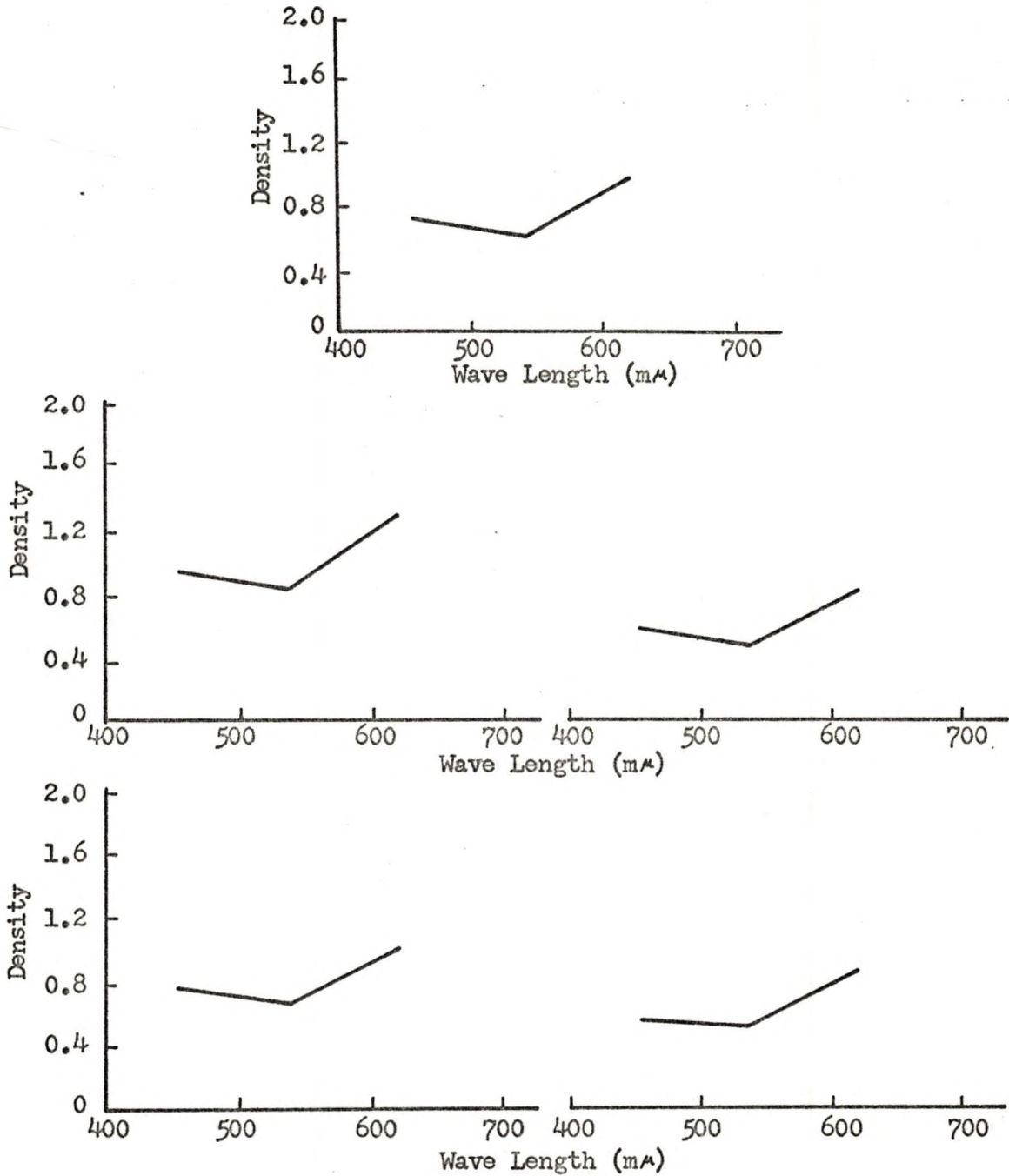

Fig. 20--Density versus Wave Length for Grass on Ektachrome Film

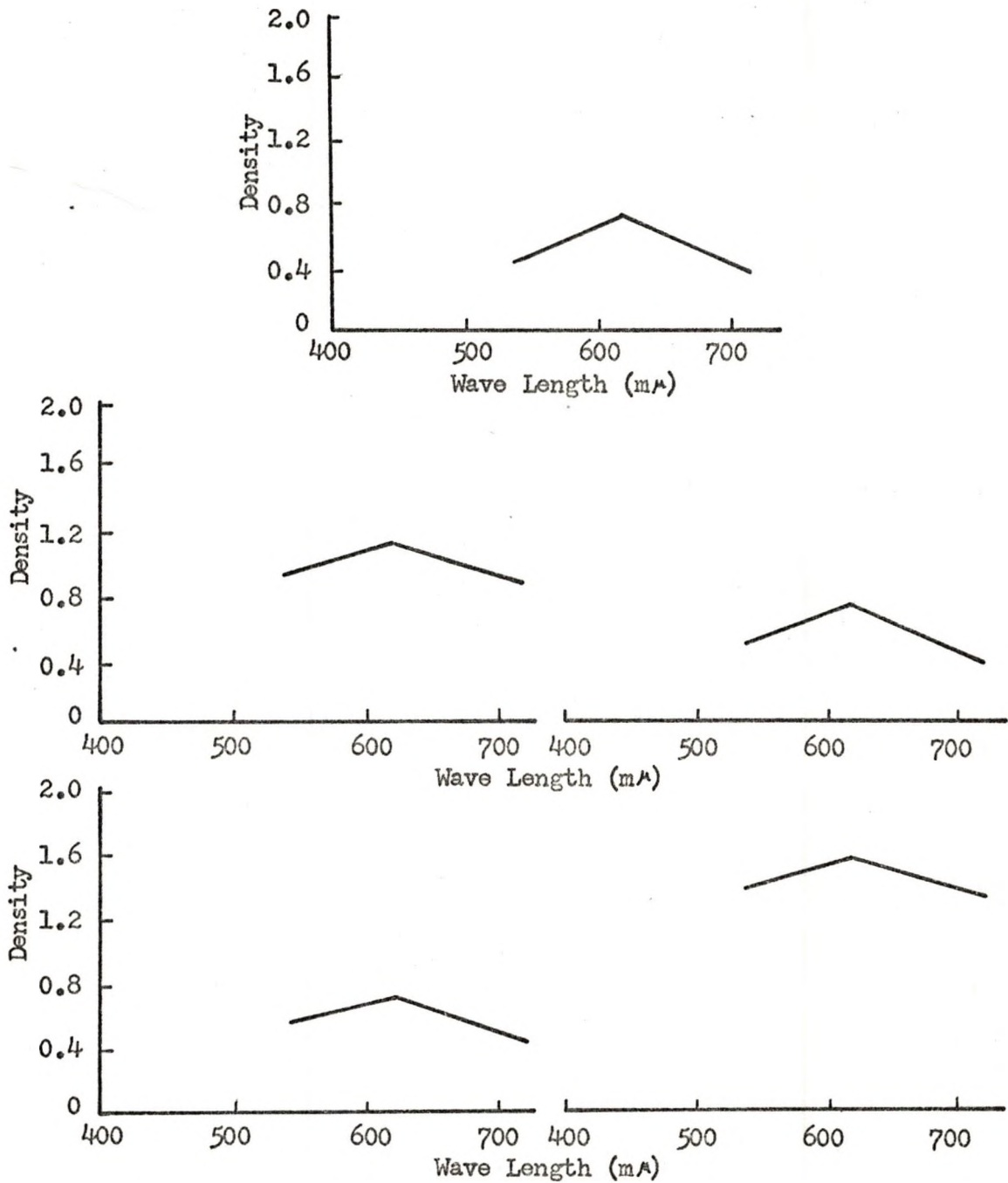

Fig. 21--Density versus Wave Length for Coniferous Trees on Infrared Ektachrome Film

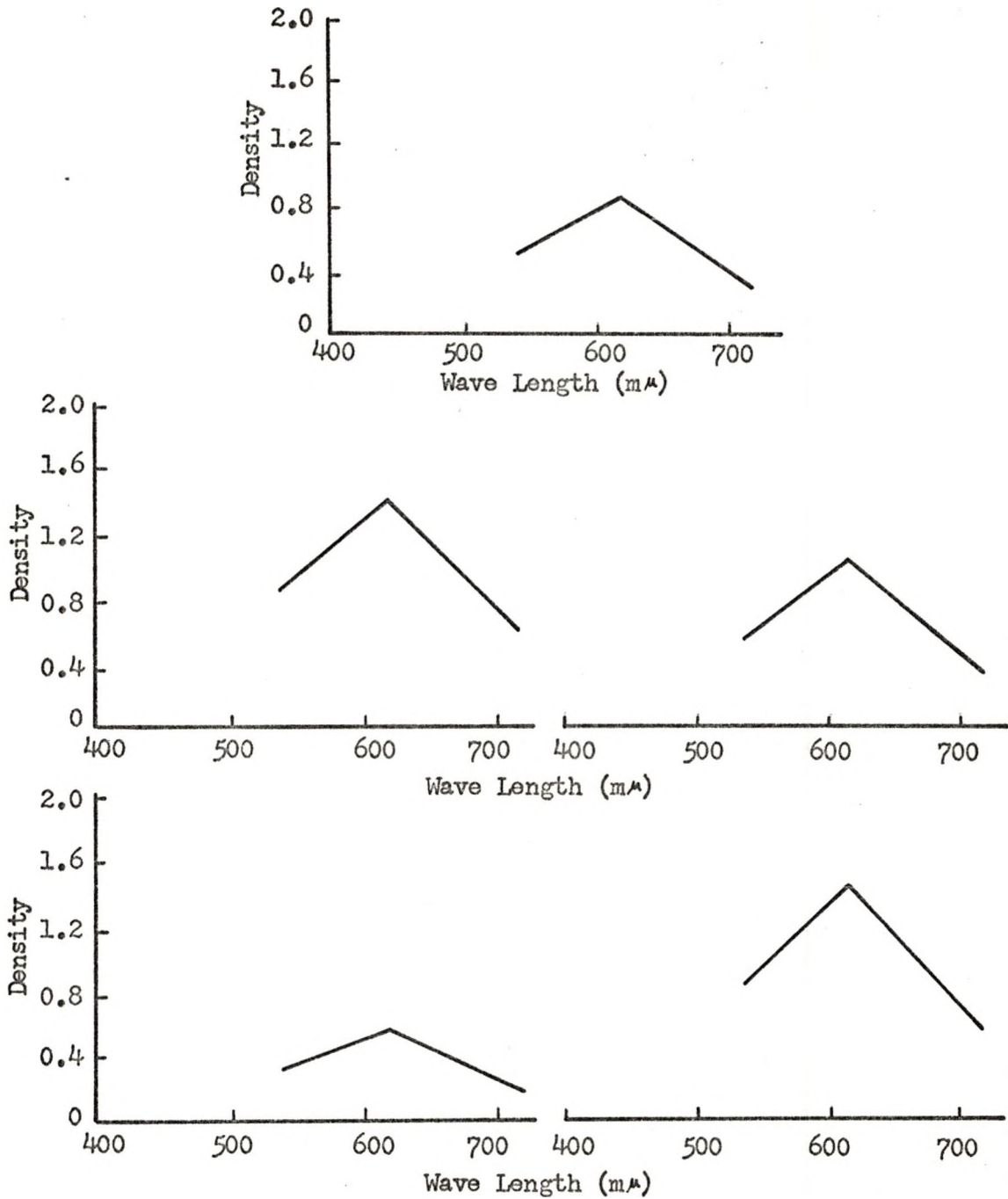

Fig. 22--Density versus Wave Length for Deciduous Trees on Infrared Ektachrome Film

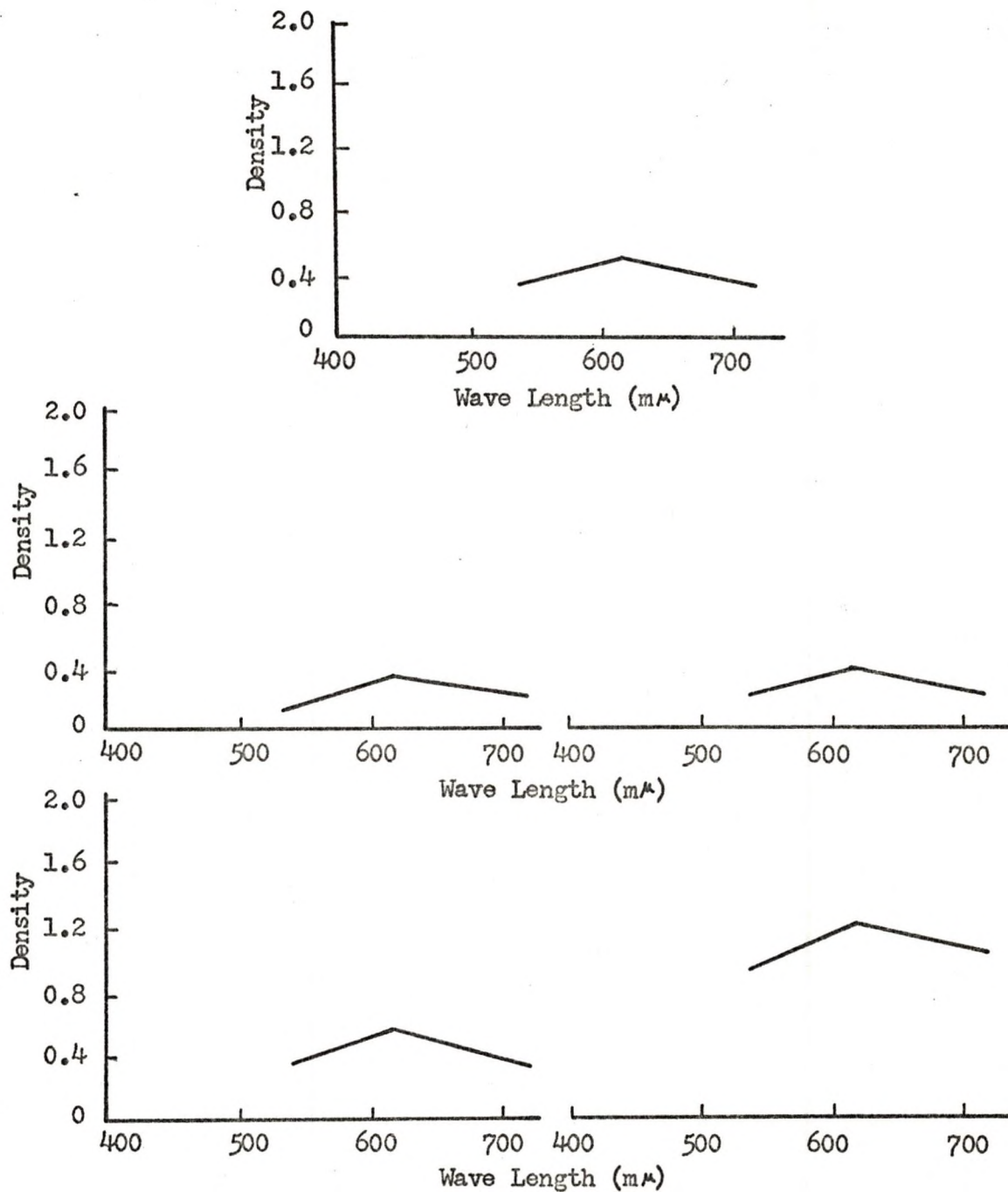

Fig. 23--Density versus Wave Length for Grass
on Infrared Ektachrome Film

TABLE 8

DENSITY SLOPE FROM SEPARATION POSITIVES

B-G	G-R	R-IR
Coniferous Trees		
-0.18	+0.18	-1.07
-0.10	+0.19	-1.55
-0.12	+0.18	+1.53
-0.50	+0.29	-1.06
-0.50	+0.64	-1.35
Deciduous Trees		
-0.36	+0.18	-1.12
-0.60	+0.09	-1.29
-0.38	+0.27	-0.71
-0.66	+0.18	-0.76
-0.20	+0.15	-1.35
Grass		
-0.42	+0.18	-1.12
-0.70	+0.35	-0.76
-0.48	+0.18	-0.79
-0.59	+0.18	-0.67
-0.45	+0.21	-0.68

constant and reliable.

Chi-Square contingency tables were calculated for each of the target-film combinations to test the above evaluation. A sample equation for Chi-Square contingency tables is presented in Appendix II. Results, tabulated in Table 14, indicate that there is no association between the individual tone signatures for separation positive density slope tone signatures at either the 0.05 or 0.01 confidence level. Therefore, it can be assumed the differences in density slope tone signature for the separation positives are not due to chance or sampling variation and that the calculated average density slope tone signature is not reliable for

TABLE 9
 DENSITY SLOPE FROM
 EKTACHROME FILM

B-G	G-R
Coniferous Trees	
+0.17	+0.38
+0.12	+0.53
+0.08	+0.53
+0.13	+0.51
+0.12	+0.44
Deciduous Trees	
-0.06	+0.50
-0.10	+0.50
-0.05	+0.63
-0.06	+0.35
-0.09	+0.53
Grass	
-0.10	+0.42
-0.07	+0.43
-0.12	+0.47
-0.16	+0.43
-0.09	+0.44

use in identification.

However, Chi-Square indicates that there is an association between the member tone signatures for the Ektachrome and Infrared Ektachrome films at the 0.01 and the 0.05 confidence level. It is assumed that fluctuations present result from chance and sampling variation and that the calculated average density slope tone signatures are significant and usable as a means of identification for the targets presented.

TABLE 10

DENSITY SLOPE FROM INFRARED
EKTACHROME FILM

G-R	R-IR
Coniferous Trees	
+0.25	-0.30
+0.25	-0.23
+0.25	-0.25
+0.29	-0.26
+0.19	-0.22
Deciduous Trees	
+0.32	-0.39
+0.76	-0.94
+0.76	-0.87
+0.63	-0.72
+0.48	-0.46
Grass	
+0.29	-0.23
+0.28	-0.22
+0.26	-0.15
+0.25	-0.17
+0.25	-0.20

TABLE 11

DENSITY SLOPE TONE SIGNATURE
FROM SEPARATION POSITIVES

Subject	B-G	G-R	R-IR
Coniferous Trees	-0.28	+0.30	-1.31
Deciduous Trees	-0.44	+0.17	-1.04
Grass	-0.52	+0.22	-0.80

TABLE 12

DENSITY SLOPE TONE SIGNATURE
FROM EKTACHROME FILM

Subject	B-G	G-R
Coniferous Trees	+0.12	+0.48
Deciduous Trees	-0.07	+0.50
Grass	-0.11	+0.44

TABLE 13

DENSITY SLOPE TONE SIGNATURE FROM
INFRARED EKTACHROME FILM

Subject	G-R	R-IR
Coniferous Trees	+0.25	-0.25
Deciduous Trees	+0.59	-0.68
Grass	+0.27	-0.19

TABLE 14
CHI-SQUARE FOR DENSITY SLOPE DETERMINATION

Subject	χ^2 Calculated	Significant difference between χ^2 calculated and χ^2 table*
Separation Positives		
Coniferous Trees	91.86	Yes
Deciduous Trees	64.47	Yes
Grass	26.93	Yes
Ektachrome		
Coniferous Trees	5.55	No
Deciduous Trees	3.02	No
Grass	4.36	No
Infrared Ektachrome		
Coniferous Trees	0.63	No
Deciduous Trees	1.83	No
Grass	0.61	No

*0.05 and 0.01 level of confidence

CHAPTER IV

CONCLUSIONS

The use of density slope tone signature appears to be more reliable than density tone signature. Chi-Square Contingency tables for the Infrared Ektachrome Density tone signatures produces an X^2 of 60.74 which is highly significant at either the .05 or .01 level of confidence. This indicates that the density readings are independent of each other and differences could not be due to chance or sampling variation. Since Chi-Square indicates that the density slope tone signatures from Infrared Ektachrome are the most related it is assumed from the above that density tone signatures for separation positives and Ektachrome are less dependent than the Infrared Ektachrome density tone signatures and therefore of less value.

The density fluctuations are attributed to film exposure, development differences and low oblique photography. The larger fluctuations of the separation positives are also attributed to error in the standardization procedure which is difficult to control. Low oblique photography is believed to have caused most of the fluctuations in density. Reflectance properties of surface objects are most variable when the energy detector is at a low altitude because of the non-integrated reflectance readings. At low altitudes leaf morphometry and leaf attitude have a much greater variance than they would have on high oblique or high altitude vertical photography.

With low altitude photography the angle of incidence of the sun

varies more with respect to the observer than it would at a higher altitude, high oblique or vertical shot.

It appears that the density slope method of tone signature can compensate for density fluctuations as long as the relative density difference between adjacent bands remains constant. If, as in the case of the separation positives, the relative density differences also fluctuate, the density slope method works no better than density tone signature. This feature is attributed to error in the standardization procedure.

From the data collected in this investigation and the analysis performed it appears that, with normal photographic equipment and procedures, Ektachrome or Infrared Ektachrome film and the density slope method of tone signature calculation produce the most reliable and usable tone signatures.

Suggestions for Further Research

The density slope tone signature method must be tested over a wider range of subjects and under varying conditions of climate and location before a usable identification key can be developed. High oblique and vertical photography should be used for any further investigations of this nature. Investigations concerning the amount of variance in density resulting from altitude and energy detector attitude compared to target location must be determined before a reliable standard procedure of tone signature can be attained.

A future application of a reliable tone signature key could possibly be automatic photo interpretation. Micro-densitometers with electronic read-outs coupled to computers with programmed tone signatures could furnish the investigator a read-out of a photographed area with the programmed features identified and locations indicated on a map.

APPENDIX I

Average slope of separation negative characteristic curve, Figure 12, was calculated as 0.7. The slope intercept equation for the characteristic curve was used in calculating theoretical positive densities (Y) from the observed negative densities (X).

$$y = mx + b$$

$$y = 0.7x + 1.70$$

TABLE 15

THEORETICAL POSITIVE DENSITIES FROM OBSERVED NEGATIVE DENSITIES

Negative Densities					Calculated Theoretical Positive Densities			
Blue	Green	Red	Infrared	Subject	Blue	Green	Red	Infrared
Coniferous Trees								
0.63	0.74	0.65	1.40		1.52	1.36	1.50	0.42
0.44	0.51	0.40	1.50		1.79	1.70	1.85	0.28
0.42	0.49	0.39	1.48		1.82	1.72	1.86	0.31
0.51	0.81	0.66	1.40		1.51	1.08	1.59	0.22
Deciduous Trees								
0.74	0.96	0.86	1.66		1.36	1.05	1.19	0.06
0.34	0.70	0.66	1.56		1.94	1.42	1.49	0.19
0.86	1.10	0.94	1.46		1.19	0.86	1.08	0.34
0.60	1.00	0.90	1.44		1.57	1.00	1.14	0.37
0.48	0.60	0.54	1.50		1.74	1.57	1.65	0.28
Grass								
0.70	0.93	0.84	1.63		1.42	1.08	1.22	0.09
0.79	1.22	1.04	1.58		1.28	0.68	0.94	0.17
0.76	1.06	0.97	1.52		1.33	0.91	1.05	0.25
0.70	1.06	0.97	1.44		1.42	0.91	1.05	0.37
0.85	1.14	1.02	1.50		1.19	0.80	0.97	0.28

APPENDIX II

CHI-SQUARE CONTINGENCY TABLE

	I	II	Totals
A	29	23	52
B	28	22	50
C	26	15	41
D	25	17	42
E	25	20	45
Totals	133	97	230

H_0 = No significant difference in X^2 calculated and X^2 table or the variables are dependant or related.

$$X^2 = \frac{N}{N_A} \left[\frac{a_1^2}{N} + \frac{a_2^2}{N} \right] + \frac{N}{N_B} \left[\frac{b_1^2}{N} + \frac{b_2^2}{N} \right] + \frac{N}{N_C} \left[\frac{c_1^2}{N} + \frac{c_2^2}{N} \right] + \frac{N}{N_D} \left[\frac{d_1^2}{N} + \frac{d_2^2}{N} \right] + \frac{N}{N_E} \left[\frac{e_1^2}{N} + \frac{e_2^2}{N} \right] - N$$

$$X^2 = \frac{230}{52} \frac{29}{133} + \frac{23}{97} + \frac{230}{50} \frac{29}{133} + \frac{22}{97} + \frac{230}{41} \frac{26}{133} + \frac{15}{97} + \frac{230}{42} \frac{25}{133} + \frac{17}{97} + \frac{230}{45} \frac{25}{133} + \frac{20}{97} - 230$$

X^2 calculated + 0.61

degrees of freedom +4

$$X^2 + 9.49 \quad X^2 = 13.3$$

X^2 cal. < X^2 table accept H_0

BIBLIOGRAPHY

Books

- Baines, H. The Science of Photography. New York: John Wiley & Sons, 1960.
- Boucher, Paul A. Fundamentals of Photography. Princeton, New Jersey: D. Van Nostrand Co., Inc., 1963.
- Colwell, Robert N. "Procurement of Aerial Photography," Manual of Photographic Interpretation. Washington, D.C.: American Society of Photogrammetry, 1960.
- Eastman Kodak Company. Color Separation and Masking. Rochester, New York: Eastman Kodak Co., 1959.
- Eastman Kodak Company. Data for Aerial Photography. Rochester, New York: Eastman Kodak Co., 1968.
- Eastman Kodak Company. Kodak Wratten Filters. Rochester, New York: Eastman Kodak Co., 1965.
- Inglis, Stuart J. Planets, Stars and Galaxies. New York: John Wiley & Sons, Inc., 1961.
- Krinov, E. L. Spectral Reflectance Properties of Natural Formations. Translated by G. Belkor. Ottawa: National Research Council of Canada, Technical Translation 439, 1953.
- Orr, Donald G. "Multiband-color Photography." Manual of Color Aerial Photography. Falls Church, Virginia: American Society of Photogrammetry, 1968.
- Pohl, Herbert A. Quantum Mechanics for Science and Engineering. Englewood Cliffs, New Jersey: Prentice-Hall, Inc., 1967.
- Quackenbush, Robert S. "Development of Photo Interpretation." Manual of Photographic Interpretation. Washington, D.C.: American Society of Photogrammetry, 1960.
- Sellers, William D. Physical Climatology. Chicago: University of Chicago Press, 1965.
- Shortley, George and Dudley Williams. Elements of Physics. Englewood Cliffs, New Jersey: Prentice-Hall, Inc., 1961.

Proceedings

- Colwell, Robert N. "Uses and Limitations of Multispectral Remote Sensing." Proceedings of the Fourth Symposium on Remote Sensing of Environment. Rev. ed.; Ann Arbor: Willow Run Laboratories, The Institute of Science and Technology, University of Michigan, 1961.
- Hoffer, Roger M., Roger A Holmes, and J. Ralph Shay. "Vegetative Soil and Photographic Factors Affecting Tone in Agricultural Remote Multispectral Sensing." Proceedings of the Fourth Symposium on Remote Sensing of Environment. Rev. ed.; Ann Arbor: Willow Run Laboratories, The Institute of Science and Technology, University of Michigan, 1966.

Periodicals

- Colwell, Robert N. "Some Practical Applications of Multiband Spectral Remote Sensing." American Scientist. XLIX (No. 9, 1967), pp. 9-36.
- Report of Subcommittee I on Photo Interpretation, American Society of Photogrammetry. Basic Matter and Energy Relationships Involved in Remote Reconnaissance." Photogrammetric Engineering. XXIX (No. 5, 1963), pp. 761-798.
- Sorem, Alan L. "Principles of Aerial Color Photography." Photogrammetric Engineering. XXXIII (No. 9, 1967), pp. 1008-1017.

Unpublished Articles

- Eyton, J. Ronald. "Multispectral Photography." Unpublished paper, University of North Dakota, 1968.