

Air Force Institute of Technology

**AFIT Scholar**

---

Theses and Dissertations

Student Graduate Works

---

3-2002

## **Modeling Aerospace Ground Equipment (AGE) Usage in Military Environments**

Ilhan Kaya

Follow this and additional works at: <https://scholar.afit.edu/etd>



Part of the [Operations and Supply Chain Management Commons](#)

---

### **Recommended Citation**

Kaya, Ilhan, "Modeling Aerospace Ground Equipment (AGE) Usage in Military Environments" (2002).  
*Theses and Dissertations*. 4517.  
<https://scholar.afit.edu/etd/4517>

This Thesis is brought to you for free and open access by the Student Graduate Works at AFIT Scholar. It has been accepted for inclusion in Theses and Dissertations by an authorized administrator of AFIT Scholar. For more information, please contact [richard.mansfield@afit.edu](mailto:richard.mansfield@afit.edu).



**MODELING  
AEROSPACE GROUND EQUIPMENT (AGE)  
USAGE IN MILITARY ENVIRONMENTS**

**THESIS**

**Ilhan Kaya, First Lieutenant, TUAF**

**AFIT/GOR/ENS/02-11**

**DEPARTMENT OF THE AIR FORCE  
AIR UNIVERSITY**

**AIR FORCE INSTITUTE OF TECHNOLOGY**

---

---

**Wright-Patterson Air Force Base, Ohio**

APPROVED FOR PUBLIC RELEASE; DISTRIBUTION UNLIMITED.

## Report Documentation Page

<b>Report Date</b> 01 Sep 2001	<b>Report Type</b> Final	<b>Dates Covered (from... to)</b> June 2001 - Sep 2002
<b>Title and Subtitle</b> Modeling Aerospace Ground Equipment (AGE) Usage in Military Environments	<b>Contract Number</b>	
	<b>Grant Number</b>	
	<b>Program Element Number</b>	
<b>Author(s)</b> Ilhan Kaya, 1st Lt, TAAF	<b>Project Number</b>	
	<b>Task Number</b>	
	<b>Work Unit Number</b>	
<b>Performing Organization Name(s) and Address(es)</b> Air Force Institute of Technology Graduate School of Engineering and Management (AFIT/EN) 2950 P Street, Bldg 640 WPAFB, OH 45433-7765	<b>Performing Organization Report Number</b> AFIT/GOR/ENS/02-11	
<b>Sponsoring/Monitoring Agency Name(s) and Address(es)</b>	<b>Sponsor/Monitor's Acronym(s)</b>	
	<b>Sponsor/Monitor's Report Number(s)</b>	
<b>Distribution/Availability Statement</b> Approved for public release, distribution unlimited		
<b>Supplementary Notes</b> The original document contains color images.		
<b>Abstract</b> The U.S. Air Force is developing Modular Aircraft Support System (MASS) program to replace the current Aerospace Ground Equipment (AGE). AGE supplies electricity, nitrogen, hydraulics and other support equipment to maintenance activities at the flight line. Current AGE makes up one-third of the deployment footprint. AGE is also mostly aircraft specific, and has reliability problems. The MASS alternative focuses on modularity based on a plug-and-play approach. The technological improvements and possible reduction in the footprint make MASS a good alternative. The AF has to determine now, whether MASS can supply similar functionality and decrease the deployment footprint to theater, while not degrading logistics support for the missions. The primary focus in this thesis is to determine the important factors that have impacts on Flying Scheduling Effectiveness (FSE), to decrease the footprint related to the important factors and MASS substitution. The maintenance requirements are examined for the flight line support of 3 types of aircrafts (F16CJ, F15C, and F15E) sent to the theater for the Aerospace Expeditionary Force (AEF) and for 7-days period. This thesis re-engineers the AWESIM model created by OFearna (1999) and extended by Festejo (2000), into ARENA software. The use of Response Surface Methodology (RSM) with simulation is introduced.		

**Subject Terms**

Aerospace Ground Equipment, AGE, Modular Aircraft Support System, Multifunctional Aerospace Support System, MASS

**Report Classification**

unclassified

**Classification of this page**

unclassified

**Classification of Abstract**

unclassified

**Limitation of Abstract**

UU

**Number of Pages**

92

The views expressed in this thesis are those of the author and do not reflect the official policy or position of the United States Air Force, Department of Defense, or the US Government.

AFIT/GOR/ENS/02-11

**MODELING**  
**AEROSPACE GROUND EQUIPMENT (AGE)**  
**USAGE IN MILITARY ENVIRONMENTS**

THESIS

Presented to the Faculty  
Department of Operational Sciences  
Graduate School of Engineering and Management  
Air Force Institute of Technology  
Air University  
Air Education and Training Command  
In Partial Fulfillment of the Requirements for the  
Degree of Master of Science in Operations Research

Ilhan Kaya, B.S.

1<sup>st</sup> Lieutenant, TUAF

March 2002

APPROVED FOR PUBLIC RELEASE; DISTRIBUTION UNLIMITED

**MODELING**  
**AEROSPACE GROUND EQUIPMENT (AGE)**  
**USAGE IN MILITARY ENVIRONMENTS**

Ilhan Kaya  
1<sup>st</sup> Lieutenant, TUAF

Approved:

\_\_\_\_\_  
Raymond R. Hill, Lt Col, USAF (Chairman)  
Associate Professor of Operations Research

\_\_\_\_\_  
date

\_\_\_\_\_  
John O. Miller, Lt Col, USAF (Member)  
Assistant Professor of Operations Research

\_\_\_\_\_  
date

## **Acknowledgements**

I would like to thank many people whose contributions helped me to complete this hard work at AFIT. I would like to express my sincere appreciation to my faculty advisor, Lt Col Raymond R. Hill, for his guidance, direction and understanding that kept me on track to finish my work. Thanks also go to Lt Col J. O. Miller for answers to my questions as a reader on my thesis.

I would like to thank Capt Frank O’Fearn and Capt Reginald P. Festejo for their previous works that helped me to understand the subject and to build my own thesis. Thanks to my classmates and other personnel for their understanding and answering my every question patiently.

Ilhan Kaya



## Table of Contents

	Page
Acknowledgements .....	iv
List of Figures .....	vii
List of Tables .....	viii
Abstract .....	ix
I. Introduction and Statement of Problem .....	1
Introduction .....	1
Problem .....	3
Objective .....	5
Approach .....	5
Scope .....	6
II. Background and Literature Review .....	1
Overview .....	1
Aerospace Ground Equipment (AGE) .....	1
Expeditionary Aerospace Force/Aerospace Expeditionary Forces .....	6
Two-Level Maintenance (2LM) .....	12
Agile Combat Support/Lean Logistics//Just-In-Time practices .....	14
Multifunction Aerospace Support System (MASS) Design .....	17
Summary .....	19
III. Methodology .....	20
Introduction .....	20
Simulation with ARENA and Excel .....	20
Model Structure and Assumptions .....	22
The Input Data and Related Issues .....	26
Analysis Methodology .....	32
Summary .....	34
IV. Results and Analysis .....	35
Introduction .....	35
Within AGE, Analysis Results .....	35
Between AGE, Analysis Results .....	39
The Footprint .....	41
Summary .....	42

	Page
V. Conclusions and Recommendations .....	43
Introduction .....	43
Interpretations.....	43
Conclusions .....	44
Recommendations .....	45
Appendix A. The Model/Sub-models/VBA Code .....	46
Appendix B. Schedule of The Sorties and The Number of Aircrafts .....	53
Appendix C. Within AGE Analysis/Surface Screening 2 LEVEL .....	54
Appendix D. Within AGE Analysis/Fitting Model .....	60
Appendix E. Within AGE Analysis/(only AGE) Response-Fitting Model .....	63
Appendix F. Between AGE/AGE-MASS Analysis .....	66
Appendix G. The Footprint Dimensions and Subtotals .....	70
Bibliography.....	72
Vita .....	75

## List of Figures

Figure	Page
Figure 1. Recent USAF Deployments (Galway et al, 2000:2).....	2
Figure 2. A/M32C-10D.....	2
Figure 3. A/M32A-60A.....	2
Figure 4. Nitrogen Servicing Unit.....	3
Figure 5. MC-1A.....	3
Figure 6. Breakdown of Support for AEF 4 (Galway et al, 2000:10).....	4
Figure 7. ACC Standard Deployment Timelines (Galway et al, 2000:6).....	9
Figure 8. EAF Support Model Components (Galway et al, 2000:14).....	11
Figure 9. Lean Logistics Concept in General (Patnode, 1999).....	16
Figure 10. Multifunction Aerospace Support System (MASS) (Boyle et al, 1995:29) ...	19
Figure 11. Model Flow Chart.....	23
Figure 12. The Interactions between the Main Factors.....	37
Figure 13. The Interactions for AGE Response-Fitting Model.....	38

## List of Tables

Table	Page
Table 1. Current Deployment Levels of AGE for AEFs.....	26
Table 2. Aircraft Abort Rate on the Ground .....	27
Table 3. Aircraft Sortie Duration Data from Mt. Home AFB.....	27
Table 4. The Break Rates for Post-flight Inspection.....	27
Table 5. Quick-turn Times for the Aircrafts without failure.....	28
Table 6. The Percentages Related to the Number of Failures.....	28
Table 7. The Travel Times for AGE .....	29
Table 8. Last Inspection/Loading/Preparation Data.....	29
Table 9. The Last Inspection and Servicing Failure Rates for Aircraft Types.....	29
Table 10. Equivalent AGE and MASS modules for F-16CJ.....	30
Table 11. Equivalent AGE and MASS modules for F-15C/E.....	30
Table 12. Action-Taken Codes used .....	31
Table 13. The Screening Experiment Design Values .....	32
Table 14. The Response-Fitting Model Values (Aircraft/Simulation time included).....	33
Table 15. The Response-Fitting Model Values only for AGE.....	33
Table 16. The Reduced and Maximum AGE Values.....	35
Table 17. The AGE Inventories Examined .....	39
Table 18. The Mean FSE Rate Comparison between AGE and MASS .....	40
Table 19. The Mean FSE Rate Comparison of AGE Current Deployment.....	40
Table 20. The Footprint Comparisons of Each Scenario .....	41

## **Abstract**

The U.S. Air Force is developing Modular Aircraft Support System (MASS) program to replace the current Aerospace Ground Equipment (AGE). AGE supplies electricity, nitrogen, hydraulics and other support equipment to maintenance activities at the flight line. Current AGE makes up one-third of the deployment footprint. AGE is also mostly aircraft specific, and has reliability problems. The MASS alternative focuses on modularity based on a plug-and-play approach. The technological improvements and possible reduction in the footprint make MASS a good alternative. The AF has to determine now, whether MASS can supply similar functionality and decrease the deployment footprint to theater, while not degrading logistics support for the missions.

The primary focus in this thesis is to determine the important factors that have impacts on Flying Scheduling Effectiveness (FSE), to decrease the footprint related to the important factors and MASS substitution. The maintenance requirements are examined for the flight line support of 3 types of aircrafts (F16CJ, F15C, and F15E) sent to the theater for the Aerospace Expeditionary Force (AEF) and for 7-days period.

This thesis re-engineers the AWESIM model created by O’Fearn (1999) and extended by Festejo (2000), into ARENA software. The use of Response Surface Methodology (RSM) with simulation is introduced.

**MODELING**  
**AEROSPACE GROUND EQUIPMENT (AGE)**  
**USAGE IN MILITARY ENVIRONMENTS**

**I. Introduction and Statement of Problem**

**Introduction**

“Logistics must be simple – everyone thinks they’re an expert” (Anonymous, 1998:10).

The fall of the former Soviet Union, entrance of the computers into daily life, the improvements in the military powers (especially in the air forces), corporate mergers, instability of political world are some of the distinct features of the 20<sup>th</sup> century. When we closed the 20<sup>th</sup> century and entered the 21<sup>st</sup> century, we did not leave such changes in the past. Unfortunately, these changes created a complex, uncertain world. Concepts like time, money, resource, precision, quality... became more important than before. The complex problems of today require new solutions, methods and concepts.

The United States Air Force (USAF) is surrounded with similarly complex problems. In the 1990’s the end of the Cold War led to faster and more sweeping changes in the Department of Defense (DoD). The military downsized and budgets declined, while mission requirements shifted to include more military operations other than war whose occurrences is less predictable (Booth, 1998:1). The demand for U.S. presence or intervention has required deployments ranging in size and purpose from Operation Desert Storm and Operation Allied Force, through Northern and Southern Watch and Uphold Democracy, to humanitarian relief and noncombatant evacuation operations. Figure 1 illustrates the range of deployments the Air Force faced in the 1990s (before Operation Allied Force in Kosovo). (Galway et al, 2000:1-2)

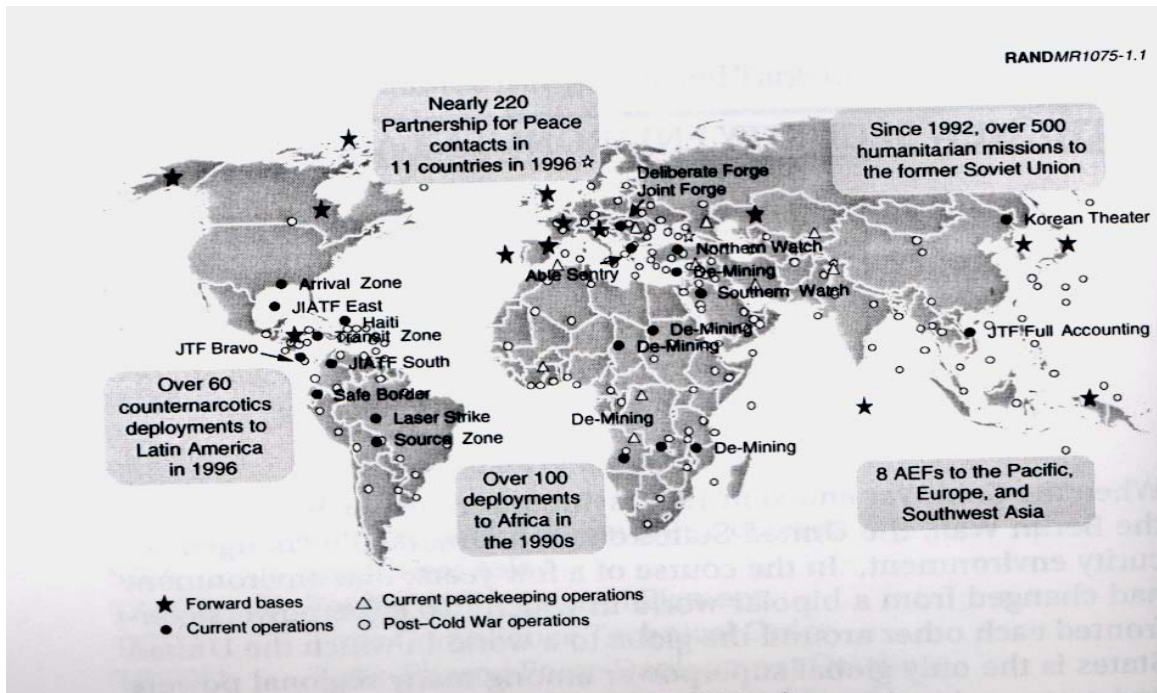

**Figure 1. Recent USAF Deployments (Galway et al, 2000:2)**

To adapt to the new modern constraints and environments, the USAF developed, and accepted new concepts and strategies like Expeditionary Aerospace Force (EAF), Agile Combat Support (ACS) and Lean Logistics (LL), Two-level Maintenance (2LM), and Just-In-Time (JIT) delivery.

The USAF also started to reevaluate every process, method and material currently used from every aspect. The reliability, maintenance, deployability, costs, environmental issues, supportability, flexibility, precision, and quality are some of the re-evaluated features. Sortie generation is needed to accomplish USAF missions, and sortie generation is related to many elements. Support equipment helps keep aircraft in flying status. AGE are important support equipment assets. This chapter discusses the AGE

problem, objectives for better flight line operations in terms of various AGE, describes a general approach, and the scope of this research.

## **Problem**

To support an unprecedented number of deployments requires improving both deployment ability and affordability of operational units. The AF seeks deployment of all operational units within 48 hours with enough resources for 7-days of operations, to any place on earth. This global view has changed how the AF views deployment. In this research, we will review the problems associated with AGE, specifically, as that AGE is needed to realize rapid global deployments.

The number, size and use of support equipment and the auxiliary tools suggest a large inventory and the need for new studies on what is really needed. The Air Force requirements change from one mission to another. The number of sorties, aircrafts, and aircraft types are determined for each mission. Whatever the missions are, AGE are an inseparable part of supporting these missions. Past studies show that the footprint of AGE, and the related tools, makes up one third of deployment requirements. Many believe the AF not only takes too much AGE on deployments, many believe the AF has too much AGE in general. Increased reliability can reduce inventories somewhat, but drastic reductions of excess AGE inventory require time analysis and scrutiny to determine what is really needed. Examples of AGE include: Electrical generators, air conditioners, hydraulics, compressors, heaters, lighting, and other wheeled machines. The more detailed explanation of AGE, which we are interested in, is given in the literature review.



The types of AGE are limited currently. The logistics support for the deployed forces or the stable bases changes daily. If the assets are not pre-positioned, deploying, and preparing the equipment to/on the Forward Operating Locations (FOLs) is a complex problem because of the uncertainties related to the place, time, required power, and other variant features of the mission. The decrease in the footprint of AGE and in the excess assets should be done without degrading the logistics support for the missions. Combining all the factors under one umbrella and examining the uncontrollable features will help to optimize the resources needed.

The problems associated with AGE are classified into four separate but interrelated issues (Tracy et al, 1997:13).

1. The age of some of the equipment and the designs used to build newer equipment.
2. AGE has not received the periodic improvements typical of aircraft or missile weapon systems.
3. The changing world order and associated changes in DoD missions, philosophies, and requirements have created deployment and affordability problems.
4. New weapon systems are on the drawing boards that radically change the utility requirements AGE must meet.

These classifications define the general AGE problem and the issues related with this research. Precisely, the problem examined in this research is how much AGE is needed and a comparison of single-function carts and multi-function carts on the flight line. Our first research hypothesis is that deployed AGE inventories can be systematically reduced. Another research hypothesis is that instead of single-function, weapon specific conventional AGE, the Modular Aircraft Support System (MASS) can

ensure the requirements for multi-weapon systems are met, while minimizing the required footprint with “plug-and-play” approach.

## **Objective**

The purpose of this research is to examine reliability and utilization of issues for AGE in various environments by building an AGE simulation model using Arena software and an Excel database. Such a model can be used to examine deployment footprint reduction plans or impacts of any overall inventory reductions.

Baseline research objectives are:

- Assess mission performance under decreased AGE inventories.
- Assess improvements due to new AGE units.
- For a given scenario, to assist in making strategic decisions with supplying an approximate AGE information to decision makers.
- To determine the best mission capability inventory requirements for AEF in terms of AGE.

## **Approach**

Using past research as a starting point -O’Fearna (1999); Festejo (2000); MacKenna (2001)... - this thesis examines the AGE problem with a simulation model created in Arena and using Excel. This discrete event simulation will model an AF flight line and logistics operations, and quantify the related parameters.

An Awesim model, created by O’Fearna and extended by Festejo, is re-engineered and extended. O’Fearna modeled a notional Air Expeditionary Force (AEF) operation containing F-16CJ, F-15C, and F-15E aircraft (Festejo, 2000). The flight line

operations were modeled for seven days and include only FOL. Our basic EAF will be based on as O’Fearna (1999):

- 12 F15Cs for Air Superiority
- 12 F15Es for ground attack with GBU-10s (2000-lb. laser-guided bombs)
- 12 F16CJs for SEAD (Suppression of Enemy Air Defense) missions (Galway et al, 2000:24).

“Seven days has emerged as a canonical planning parameter for the initial operation. Clearly, if combat operations are initiated and extended beyond seven days, daily re-supply will be a necessity” (Galway et al, 2000:24). This research will examine impacts when operations extend beyond the 7-days period.

### **Scope**

The simulation model used in this thesis utilizes the real data or the equally likely data sets to find the information like the reliability, utilization, and time between failures over the subject AGE and effects on the AEF’s Flying Scheduling Effectiveness (FSE). This thesis will focus on existing logistics support, and processes. The scenarios used by O’Fearna (1999) and Festejo (2000) are examined to validate the ARENA model produced.

## **II. Background and Literature Review**

### **Overview**

This chapter examines the existing literature, the terminology and the definitions related to the research topic.

### **Aerospace Ground Equipment (AGE)**

Support equipment is all equipment required on the ground to make a weapon system, command and control system, support system, test system, sub-system, or end item of equipment operational in its intended environment. This includes all equipment required to install, launch, arrest, guide, control, direct, inspect, test, service, calibrate, appraise, gauge, measure, repair, overhaul, assemble, disassemble, handle transport, safeguard, store, actuate, maintain or operate the system, sub-system, end item or component. (Goedeking et al, 1960:12)

Even from this definition, we can conclude that AGE is used for a broad range of operations needed on the ground for the various missions and operations. This AGE subject is one of the big interests for decades, because of the cost, footprint, and required time for transportation, inventory and other tradeoffs. The improvements for different features of the equipment are taken care of. However, technological developments are not applied to the material, unless it is related to different concepts.

In this research, Support Equipment is used as a general term, while more specifically AGE will address the carts that supply electric power, air conditioning, the gaseous nitrogen, hydraulic pressure, and low air pressure for pneumatic tools.

The different AGE models, which are in use today and of our interest, are;

- GENERATOR (AM32A-60),
- AIR CYCLE COOLING (AM32C-10),
- HYDRAULICS TEST STAND (TTU-228E),
- HIGH PRESSURE AIR COMPRESSOR (MC-1A),
- LOW PRESSURE AIR COMPRESSOR (MC-2A),
- NITROGEN CYLINDER (NG-02),

Figures 2 through 5 show four of the AGE units of interest. It is easy to see that each is fairly large.



**Figure 2. A/M32C-10D**



**Figure 3. A/M32A-60A**



**Figure 4. Nitrogen Servicing Unit**



**Figure 5. MC-1A**

These AGE models are currently used at different bases and in various operations. They are required for different purposes in the flight line. AGE is an inseparable part of the missions and aircraft maintenance. With the current technologies, we could not combine these features into aircraft, because of the cost and airframe limitations like space and weight. As separate equipment, AGE are huge, almost the size and weight of a small car. Some AGE are aircraft specific and single-function equipment. Tracy (1997) and Festejo (2000) point out that “the current models are the product of 1970s’ and the Air Force did not give the required importance to AGE inventory” (Tracy et al, 1997:13

and Festejo, 2000:9). As a result, AGE creates an important footprint problem for current deployments. “Current studies have shown that 20-30 percent of the deployment footprint of USAF operational squadron is created by AGE and its associated spares, personnel, tools, technical orders, fuel, and related items” (Tracy et al, 1997:13). “Figure 6 represents the proportions of deployments of the 4<sup>th</sup> Fighter Wing’s to Qatar; other deployments had similar patterns” (Galway et al, 2000:9).

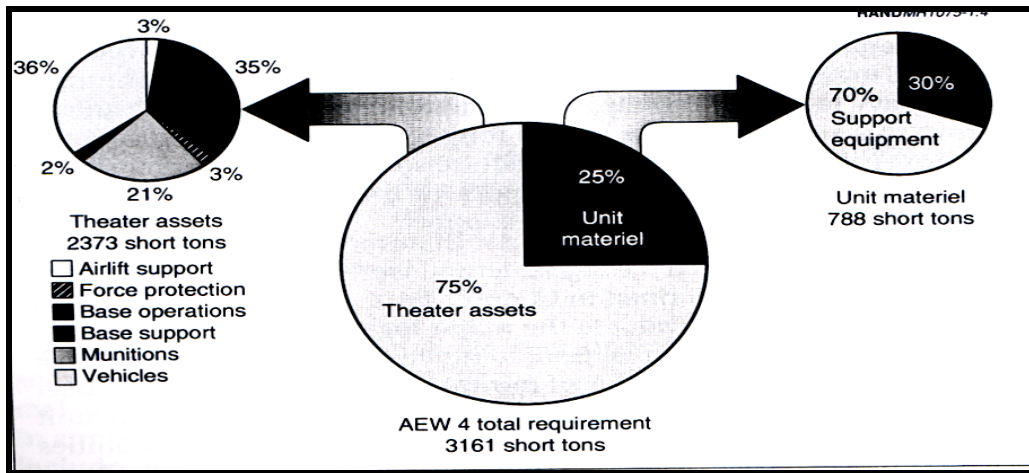

**Figure 6. Breakdown of Support for AEF 4 (Galway et al, 2000:10)**

“There are a lot of problems associated with AGE. Peculiarity is the most extended one. Many aircraft types have unique mission equipment and specialized maintenance and servicing requirements, thus each has their own array of unique and specialized support equipment” (Boyle et al, 1995:28). “Even between the same kinds of AGE, there could be differences related to different manufacturers. This means more types of spare parts, technical data, and training are needed. Reducing proliferation is an important objective of the support equipment” (Boyle et al, 1995:28). For this reason, we

are examining whether MASS is a good answer to these objectives as a new family of common AGE.

Besides the excessive numbers of AGE on the flight line, the weight and the volume features of AGE create another deployment problem. A substantial portion of the airlifted weight is flight line support equipment. Support equipment tends to be bulky and heavy, taking up an inordinate share of floor space. Thus, cargo aircraft tend to “cube out” before “weighing out”. (Boyle et al, 1995:28)

With improvements to the dimension and weight problems, more of the airlift power can be allocated to strategic forces. The time for packaging, transportation, settling, and usage can decrease distinctively. The inventory in every kind of material could diminish as will the required trained manpower. The food, living environment and subsystems for the personnel could also decrease. This kind of relations can be determined with other improvements.

The problems associated with AGE have been classified under the four issues presented in chapter 1.

Many of the basic AGE designs and some of the actual equipment in use today were created between the late 1950's and 1970. The equipment was large, heavy, with only one function per cart. Size and weight were not a big problem at the time because most equipment was pre-positioned to support anticipated military requirements. (Tracy et al, 1997:13)

“The carts were also built to support multiple weapon systems with time. For this reason, the required features were added to the old carts. The result is many carts are as large as a small car and can weigh over two tons” (Tracy et al, 1997:13).

“During the 1970's, many weapon systems were improved using electronic technology and design techniques. Unfortunately, these improvements did not reach



down into the AGE domain” (Tracy et al, 1997:13). “There was an effort to combine the air conditioner with a generator into one cart. However, the result of this effort was worse than the older equipment and the concept was abandoned” (Tracy et al, 1997:13).

The EAF concept was adopted by Air Force as a means to deploy globally, quickly, from Continental United States (CONUS) location. This concept requires much effort on AGE. As Force packages change from mission to mission, so do the support requirements. Air Force has to know every detail about AGE to decrease the footprint, time, and cost. For being rapid, light and efficient on every kind of missions, Air Force has to give right kind of decisions. AGE plays a key role on these decisions. Snow (1958) indicates this as; “No present day aircraft can be maintained operationally ready unless it is adequately backed by the proper ground support equipment” (Snow et al, 1958:1).

For example, “in the DESERT SHIELD, each 24-plane fighter squadron that deployed required the equivalent of 20 C-141 airlift cargo loads of over 70,000 pounds each to support their initial deployment and operating capability” (Snyder and Smith, 1998:21). As a simple percentage 5 C-141 and 18,000 pounds of the cargo were associated with AGE and related issues. Therefore, efforts to reduce this deployment footprint may yield significant savings.

### **Expeditionary Aerospace Force/Aerospace Expeditionary Forces**

After cold war era, the security environments for every country changed. As the remaining global power, the U.S. has to follow the trends of different environments and respond to a variety of challenges quickly with a decreased number of troops stationed

overseas. The U.S. military, and Air Force also face decreased budgets, and resources. The increased challenging demands mean increased workload and operational turbulence, which has forced the U.S. to formulate new strategies and concepts.

The Expeditionary Aerospace Force (EAF) is the most important new concept. With this concept, U.S. seeks rapid responses, accomplished by tailored force packages and minimal logistics requirements, to anywhere in the world. Under this concept, the response to a fast-breaking crisis area from bases primarily in the CONUS, contrasts with the previous posture where forces were deployed overseas in areas of concern for lengthy periods as deterrents or in anticipation of crisis situations. (Galway et al, 2000:3)

General John P. Jumper, Commander, US Air Forces in Europe noted:

“The Expeditionary Air Force idea was born of a need to be able to react quickly” (Hall, 2001:24).

General Michael E. Ryan, Chief of Staff, described the cultural change of an expeditionary mindset shift by saying:

We are in the process of a significant transition in the way we do business, and an approach to operations that emphasize rapid response. The EAF is a fundamental shift in the way we think, and how we organize, train, equip, and sustain aerospace forces. (Hall, 2001:25)

“The EAF concept is a radical departure from past Air Force employment concepts. It holds promise for enhancing the Air Force’s ability to deal with a new and uncertain international environment while alleviating some of the serious readiness problems being caused by lengthy overseas deployments” (Tripp et al, 1999d:7).

Air (Aerospace) Expeditionary Forces (AEFs) are the divisions of the Air Force with nearly equivalent capabilities, within which the deployments’ order and responsibilities are rotated. The general structure is based on the mission types, which could differ from humanitarian purposes to war operations. Precisely, each AEF

must project highly capable and tailored force packages, largely from the CONUS, on short notice anywhere around the world in response to a wide range of possible operations. (Tripp et al, 1999d:3)

Festejo (2000) describes the characteristics of AEFs as rapid, aware, precise, secure, evolvable, and light. “The EAF structure consists of ten AEFs, including two pop-up contingencies and five humanitarian/ evacuation operations” (Tripp et al, 1999c:39). “Each of the five mobility wings are paired with two AEFs and are on call with their AEFs. AEFs operate on a 90-day on-call window once every 15 months. In addition to rapid force projection, this AEF rotation structure should provide more personal stability for deploying the forces” (Tripp et al, 1999a:5).

“However, this concept is still in the improvement stage. The current logistics processes prevent them from becoming as good as planned. A key challenge for the Air Force in the future is strategic planning to support the EAF. While much of the Air Force’s attention have been focused on the execution time horizon to support the EAF” (Tripp et al, 1999d:2).

The issues related to the name of the concept and the force packages create problems in discussing the subject. The clearest explanation can be given as: “The original expeditionary force package, tailored to South West Asia, was a 30- or 36-ship fighter package, which was termed an Air Expeditionary Force (AEF). The concept was broadened to include other types of missions, including humanitarian and space support (hence the replacement of “Air” by “Aerospace”)” (Galway et al, 2000:4).

“To a large degree, future global combat capability will depend on strategic choices concerning combat support system design that will be made in the near future”

(Tripp et al, 1999d:3). Enabling this concept is only possible with a valid, flexible, robust support mechanism. “Reliance on pre-positioned assets must be minimized if not eliminated. Unfortunately, analyses show that at present, pre-positioned assets cannot be eliminated” (Tripp et al, 1999c:3). “For AEFs to be effective, units must reach combat capability as soon as possible in the early stages of the conflict in order to take the advantage” (Allen and Bedesem, 1998:33). The current Air Combat Command (ACC) standard timeline for deployment and the AEF goal is shown in Figure 7.

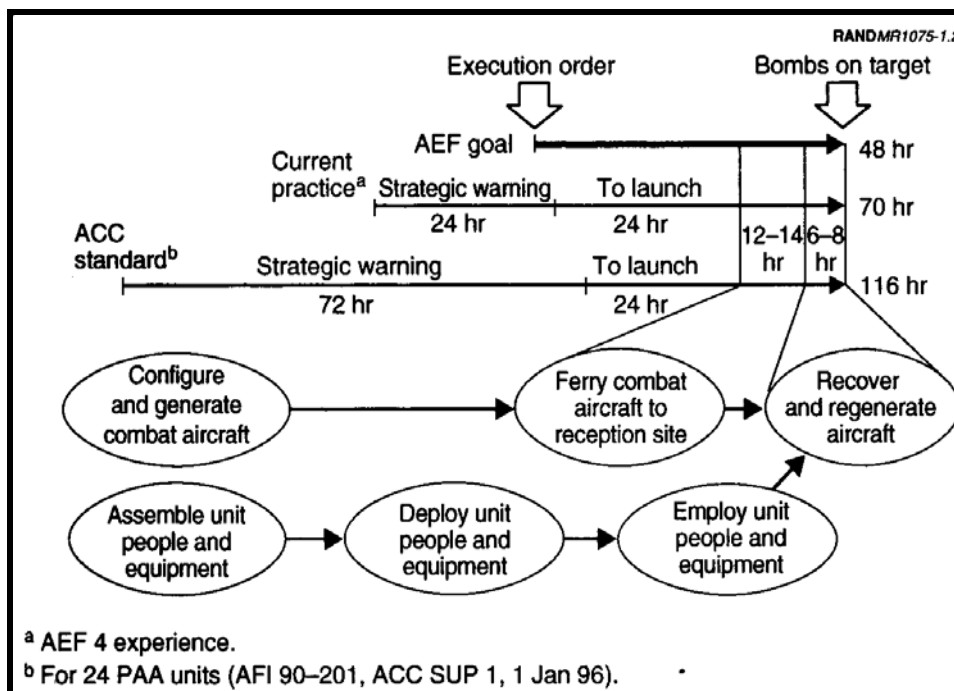

Figure 7. ACC Standard Deployment Timelines (Galway et al, 2000:6)

The success of the EAF concept is connected to the enhancements in the following areas in general:

- Supporting the entire spectrum of operations.
- Dealing with uncertainty.

- Evaluating alternative designs for deployment/employment timelines and associated costs.
- Integrating ACS planning among support functions and theaters and with operations.
- Integrating the assessment and development process for technology and policy.
- Controlling variability and improving performance (Tripp et al, 1999d:4).

As we can see, the areas above imply that the success of EAF concept ties all the concepts, strategies, and research... to one another.

The relation of this thesis to the concept can be seen in more than one area. However, the distinct connection is with the reduction of the AGE deployment footprint. “Reducing the deployment footprint provides a vivid picture of an objective that can be achieved in different ways” (Tripp et al, 1999a:5). Alternative options, instead of right or wrong answers, are possible. Also, two of the EAF goals are related directly, “(1) quick-hitting expeditionary operations and (2) deployment predictability to improve stability in the personal lives of Air Force personnel” (Feinberg et al, 2000:5).

Figure 8 shows the sections of deployment and employment planning of EAF concept, which this thesis will partially examine. The approach in this research requires mission parameters like types and numbers of aircraft, sortie rates and schedules, AGE types and numbers, acceptable FSE. This thesis assesses AGE impacts on FSE and deployment footprint for initial operating requirements (IOR).

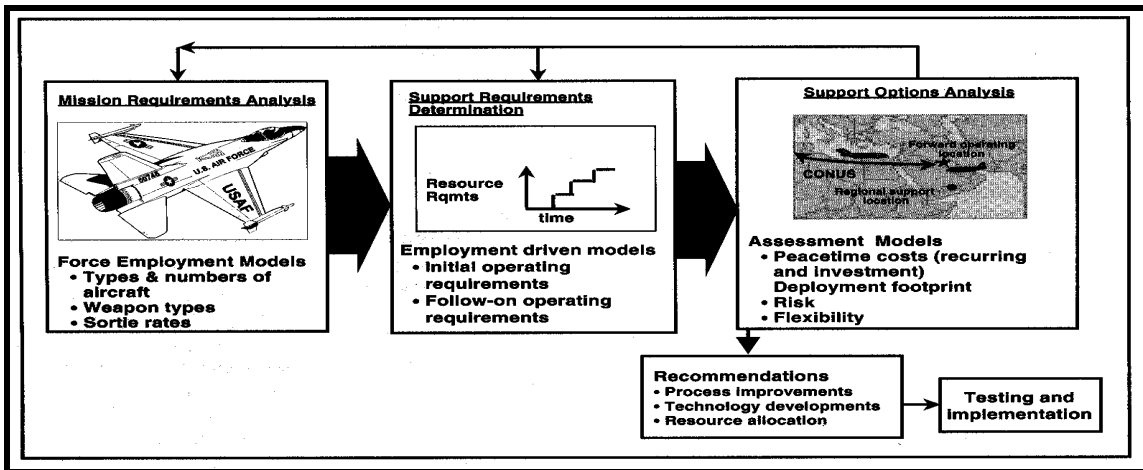

**Figure 8. EAF Support Model Components (Galway et al, 2000:14)**

“To adequately support AEFs is possible. However, support elements and operations must: (1) spin up to sustain operations almost immediately, (2) minimize airlift demands to increase the rate of deployment, and (3) have the flexibility to respond to the demands associated with highly uncertain locations and mission demands” (Tripp et al, 1999a:2). For comparing the logistics systems –current versus developed- the three points above and operational risk, investments and recurring costs should be the metrics.

RAND says that to drop the bombs on target within 48-hours is possible (the support equipment included-not with the current processes), but there will be little room for errors. “A 48-hour time line can be met with judicious pre-positioning and even then only under ideal conditions” (Tripp et al, 1999b:9). Current deployment conditions are certainly not ideal. “Current support resources and processes are heavy. They are not designed for quick deployments to operational locations” (Tripp et al, 1999b:9). Our target in this research is to determine the minimum numbers of AGE or MASS for a given scenario within the EAF concept for seven days in FOL. Optimization of IOR will

be the target for increasing the efficiency of EAF concept and to meet the operational employment objectives. “Decreasing the number of supply items in the inventory, either by combining like type items or by designing new multifunctional items, lessens the workload of the supply system. This, in turn, increases the efficiency of that system” (Davidson, 1999:13).

To support the forces, and supply continued operations are more important than to drop the bomb on target quickly, of course to achieve both is the ultimate goal. The Air Force cannot bear to have grounded aircraft during any crisis. However, the later hitting time can be bearable. The best examples can be found from past operations and even in operations in Afghanistan.

### **Two-Level Maintenance (2LM)**

“Fiscal constraints, continued downsizing, and the need to reduce our mobility footprint require the Air Force to seek innovative ways to save both money and manpower” (Chambers et al, 1996:3). Two-level Maintenance is one of these ways.

For reducing the logistics footprint and shortening the support tail, the USAF initiated some concepts. “Lean Logistics and Two-Level Maintenance are innovative management strategies allowing base-level stocking requirements and intermediate maintenance facilities to be reduced by shortening cycle times of the depot repair pipeline” (Boyle et al, 1995:28).

Two-level maintenance is not new. Germany used 2LM concept in WW-II, but it was not really effective. Other logistic concepts did not support 2LM efficiently. Lack of Just-In-Time delivery, in-transient visibility and newly developed concepts made 2LM

concept unsuccessful and ineffective. 2LM concept requires precision, and adequate inventory to be successful. In the 80's, beginning with Reliability & Maintenance (R&M) 2000, one of the significant changes in Air Force logistics processes was 2LM. "In its simplest terms, 2LM consolidates a significant amount of base-level engine and avionics repair capability including manpower, tools, and test equipment at the five depots. This initiative has dramatically reduced the number of base-level maintenance positions and resulted in a significantly reduced mobility footprint" (Chambers et al, 1996:1).

"In June 1992, 2LM was adopted for every new weapon systems. 2LM resulted in a significant reduction in the mobility footprint associated with aircraft maintenance units" (Chambers et al, 1996:3) An example of 2LM is, "removing and replacing a failed Line-Replaceable Unit (LRU), which is then repaired at the depot versus repaired at a base intermediate maintenance shop. Any base level repair in an LRU is at the Shop Replaceable Unit (SRU) level" (Burke, 1997:4). (SRUs are subcomponents of an LRU, such as circuit cards, that are easily removed and replaced.) The important point here is: there is no longer the need to deploy an intermediate maintenance shop. "2LM centralizes repair activities to take advantage of economies of scale and standardization" (Chambers et al, 1996:3).

"There is some risk of reduced readiness with 2LM. By eliminating the intermediate-level maintenance, the overall maintenance effort becomes more dependent upon transportation and supply functions to get the right part to the right place at the right time. This new dependence has contributed to an initiative known as "Lean Logistics""



(Chambers et al, 1996:2). Furthermore, 2LM became one of the key elements of first Lean Logistics and later Agile Combat Support concepts.

### **Agile Combat Support/Lean Logistics//Just-In-Time practices**

After the Cold War, the USAF remained the most powerful Air Force on Earth. However, to protect this position is now more difficult. Because of the declining military budget declines, the DoD must find ways to maintain Air Force efficiencies. The new restructured logistics system will help. “This logistics system should be: ...better, faster, more reliable and highly mobile response capability and a leaner infrastructure that better balances public/private capabilities” (Condon et al, 1999:8).

The Agile Combat Support (ACS) definition is:

Agile Combat Support creates, sustains, and protects all Air and Space capabilities to accomplish mission objectives across the spectrum of military operations. Agile Combat Support provides the capabilities that distinguish Air and Space power- speed, flexibility, and global perspective. (Hallin, 1997:1)

Under the Agile Combat Support concept, the focus of the support system shifts from maintaining massive inventories to establishing responsive capability. The key to successfully developing a responsive system is to emphasize efficient business-based management, time-sensitive responsive transportation, reduced forward-deployed inventories, accurate support command and control, and focused depot-level repair. (Hallin, 1997:2)

“Agile Combat Support places emphasis on several distinct principles that describe how our logistics community contributes to this core competency. The principles are founded on a concept called “Lean Logistics,” which the Air Force began to implement in 1994” (Hallin, 1997:1).

Colonel Arthur Morrill, former Executive Officer, Deputy Chief of Staff for Logistics, Headquarters US Air Force, described Lean Logistics as:

An interrelated series of logistics initiatives that promote capability, enhance our war fighting sustainability, shrink the logistics footprint, and reduce infrastructure. The goal is to enhance combat capability while reducing the annual operating costs of Air Force systems by adopting state-of-art business practices and streamlined processes and by reducing infrastructure throughout the Air Force Logistics Community. (Chambers et al, 1996:2)

“The capabilities inherent in the Lean Logistics concept create a system whereby the needs of a deployed force are met by responsiveness of the logistics pipeline in lieu of large stocks of spares” (Hallin, 1997:1). Lean Logistics requires rapid transportation and substantial reengineering of the depot repair processes. Also, “Lean Logistics is an enabler of two-level maintenance” (Festejo, 2000).

Although one goal of Agile Combat Support is to reduce forward-deployed inventories, even under the Air Expeditionary Force Concept, these stocks cannot be eliminated. “Deploying forces must still rely on some pre-positioned assets to spin up deployed forces and begin immediate sustainment, particularly in the areas of fuel and munitions” (Hallin, 1997:2). “This became very evident, especially while trying to establish and sustain our initial seven to ten days of combat capability” (Allen and Bedesem, 1998:34). To reduce the IOR, assessment of what a deploying force must bring with it, versus what it can obtain locally should be done carefully.

In Figure 9, “each of these bold square boxes contains a piece of the lean logistics solution. To understand how these pieces fit together to support the objective at the top, read each of the arrows in Figure 9 from tail to tip as *if...then* statements, where the ellipses serve to indicate logical *ands*” (Patnode, 1999:41).

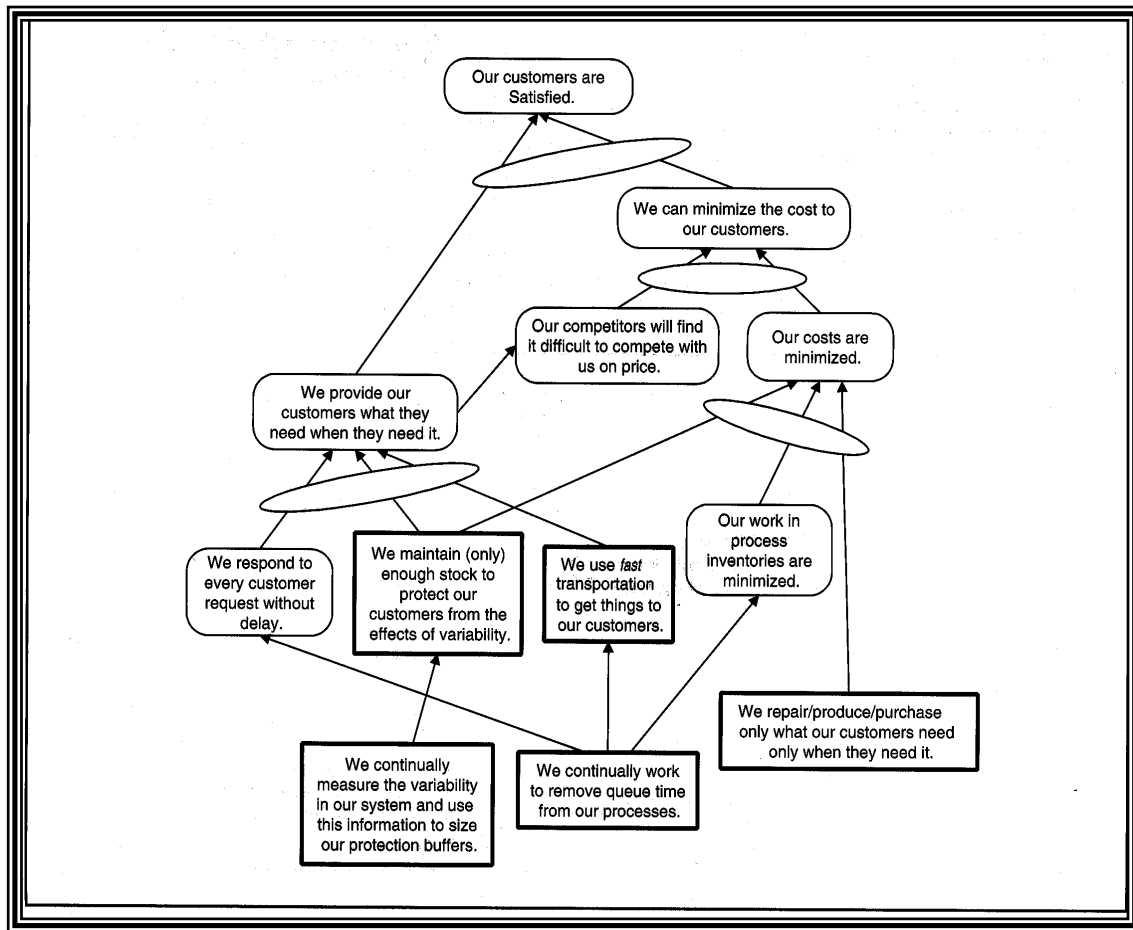

**Figure 9. Lean Logistics Concept in General (Patnode, 1999)**

A recent success story has been the evolution of two levels of maintenance to Lean Logistics to Agile Logistics. The Lean Logistics concept came about because of the need to support smaller, faster forces involved in Joint operations with a dwindling resource base and with less forward basing than the U.S. has had in over half a century. Agile Logistics is a more positive description of the collection of initiatives providing a worldwide logistics system that allows operational commanders and their combat forces to move faster, further, and with more flexibility than has ever been possible. (Hallin, 1998:1)

“The concept of time-definite re-supply embodies time-definite delivery and immediate re-supply and/or sustainment of a deployed force. By providing users with

reliable, predictable delivery of mission critical parts, time-definite delivery gives users the confidence to reduce investment in both cycle and buffer stock inventories” (Hallin, 1997:2).

Time-definite re-supply or Just-In-Time (JIT) is important for AGE. Because with this concept, the USAF can deploy only the AGE used for servicing tasks. The assumption is that other AGE will be delivered when they are required. The Lean Logistics and Agile Combat Support concepts are important, because they enable JIT, and two-level maintenance. General Zettler framed the issue in this way, “Lean Logistics and Agile Logistician are key to the EAF’s success” (Stinson et al, 1999:34).

### **Multifunction Aerospace Support System (MASS) Design**

The research objectives in this research are to analyze whether the AF can effectively reduce AGE and whether Modular Aircraft (Multifunction Aerospace) Support System (MASS) can effectively replace current AGE models. Will MASS create a smaller footprint for deployment? Will it be cost effective and more reliable? (We don’t analyze cost here but we can comment on this generally.)

MASS is a new family of common AGE. This new system will replicate the functions of current systems. These functions will support the aircraft or weapon systems from one chassis instead of separate carts. The MASS module dimensions and weight will be reduced. With plug-and-play approach, the required functions will be added or removed easily. The mission will not stop in terms of the failures within parts. The modules will not cover so much space on the airlift. The MASS modules will be sent

back to repair easily and diminish the inventory. “There will be less congestion on the flight line, so there will be fewer mishaps” (Boyle et al, 1995:28).

The vision for the MASS program is to define a new family of AGE that provides an appropriate mix of deployment ability and affordability while ensuring operational requirements are met. Thus, the effort focuses on researching and developing technologies and concepts that affordably meet all the design constraints and maximize the goals of future weapon systems as defined by the operational commands. (Tracy et al, 1997:16)

The MASS program and intended system are both built around meeting dynamic requirements. “The very concept of a modular system is to allow for the affordable tailoring of subsystems as requirements change. This is best described as building an open architecture to allow for a “plug-and-play” approach to MASS components and subsystems” (Tracy et al, 1997:16).

MASS is a valuable and feasible solution for ground support problems, which the USAF faced in terms of AGE. This solution is also not free and will probably not replace all the conventional single-function carts totally. This means it will not support all kind of weapon systems and aircraft types. However, the purpose is to combine the carts in one frame, which will support the widest possible variety of aircraft.

Festejo (2000) described the subsections of the MASS integrated product team. “Multiple organizations have concerns in this area and are very interested in developing, testing, and potentially procuring new AGE” (Tracy et al, 1997:16).

This research focuses on the following components of the MASS design; Air Compressor, Floodlight, Nitrogen Cart, Air Conditioner, Hydraulic Test Stand, Low pressure Compressor and Generator machines will take our attention. Figure 10 shows some AGE types and what we mean by MASS.

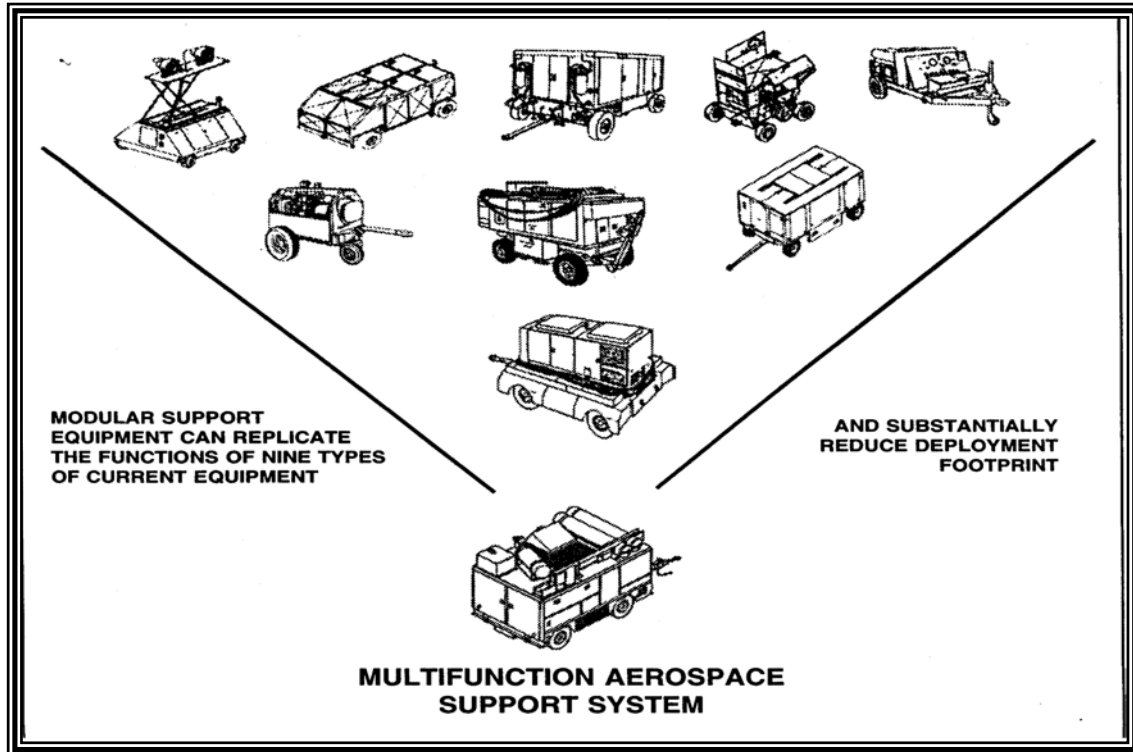

**Figure 10. Multifunction Aerospace Support System (MASS) (Boyle et al, 1995:29)**

**Summary**

This chapter introduced and discussed AGE, the new EAF and AEF concepts in use in the AF, two-level maintenance and the related concepts of Agile Combat Support, Lean Logistics, and Just-In-Time. It closed with a discussion of the new AGE system, MASS.

In the next chapter, we describe the ARENA model created for this research and how the model was used to examine AGE inventory and deployment issues.

### **III. Methodology**

#### **Introduction**

This chapter discusses the methods and methodology used in the research. This chapter generally includes the reasons why the tools are chosen, the model structure and assumptions, input data and related issues, the analysis methodology, the model Verification and Validation (V&V), the expectations from the model, and a chapter summary.

#### **Simulation with ARENA and Excel**

“Simulation is generally defined as a modeling process whereby entities (that is, objects of interest-which can include real people, machines or even failure or repair actions) interact in a defined way, over a period of time” (Johnson, 1998:17). “Joint Vision 2010 specifically cites simulation as a method of improving training realism, promoting readiness and assessing operations concepts” (Johnson, 1998:17). “Simulation is one of the most widely used operations research and management-science techniques, if not the most widely used” (Law and Kelton, 2000:2). Simulation is a powerful technique to analyze and assess the real or imaginary processes and the implications of the variants. “Simulation is the process of designing and creating a computerized model of a real or proposed system for the purpose of conducting numerical experiments to give us a better understanding of the behavior of that system for a given set of conditions” (Sadowski et al, 1998:7).

“Simulation is used when other methods are too expensive or impractical” (Johnson, 1998:17). Most times, real world problems are too complex or change too

quickly to develop an analytical model. Sometimes even the problems are impossible or destructive to analyze other than through simulation, like war scenarios. The advantages of simulation can be summarized as:

To analyze stochastic elements in problems; it may be the only possible type of investigation; allows one to estimate the performance of an existing system under assumed conditions; allows alternative systems to be compared easily; provides control over experimental conditions better than the experiments over real systems; provides study of the system for an expanded time period in a compressed time. (Law and Kelton, 2000:91)

In terms of these advantages, this thesis uses simulation to assess the AGE utilization and impacts on sortie generation. Also, “simulation is more popular and powerful than ever since computers and software are better than ever” (Sadowski et al, 1998:3). However, there are some disadvantages and pitfalls that we have to be aware of from the beginning to end.

“A primary disadvantage is that simulations give only approximate solutions instead of exact values” (Johnson, 1998:17). Validation and verification problems particularly on more complex simulators can reduce confidence in the model. These and other disadvantages are points that the analysts and decision makers should be aware of.

“ARENA combines the ease of use found in high-level simulators with the flexibility of simulation languages, and even all the way down to general-purpose procedural languages like the Microsoft Visual Basic for Application (VBA) programming system” (Sadowski et al, 1998:12). “ARENA maintains its modeling flexibility by being fully hierarchical” (Sadowski et al, 1998:13). “You can create your own modules and collect them into your own templates for various classes of systems” (Sadowski et al, 1998:13). Further, “ARENA includes dynamic animation in the same



work environment. It also provides integrated support, including graphics; for some of the statistical analysis issues that is part and parcel of a good simulation study” (Sadowski et al, 1998:13). Also, ARENA provides a friendly user interface for ease of use.

This thesis uses the VBA capabilities of ARENA for reasons like: “data is already exists in an external application, allows development of professional data entry forms, development of complex models that give inexperienced users the ability to alter model parameters, form menus and options allow an easy and structured method for scenario changes...”(Rockwell Software). VBA is general-purpose software to link Excel spreadsheets and ARENA templates quickly and easily. Furthermore, the Excel spreadsheets are easy to use, and to collect data, and user-friendly. Thus, the use of Excel spreadsheet is inevitable in some cases.

### **Model Structure and Assumptions**

In 1999, O’Fearná modeled a discrete-event simulation for sortie generation that compared Conventional AGE (CAGE) and MASS (O’Fearná, 1999). In 2000, Festejo extended the research to include flight line travel times and AGE reliability considerations (Festejo, 2000). This thesis develops a discrete event simulation in ARENA, and with VBA, that uses similar measures of performances (MOP) for a 7-day EAF concept. Some parts like inputs bases are similar to previous works, yet the new extensions and improvements are attached to this research’s model. The simulation model and submodel interfaces can be found in Appendix A. Submodels include:

1. Arrival,
2. Apron,
3. Schedule,
4. Taxi to departure,
5. Sortie,
6. Post inspection,
7. Repair,

The model is created with the sub models above and the general flow of entities (aircraft types) is displayed in Figure 11:

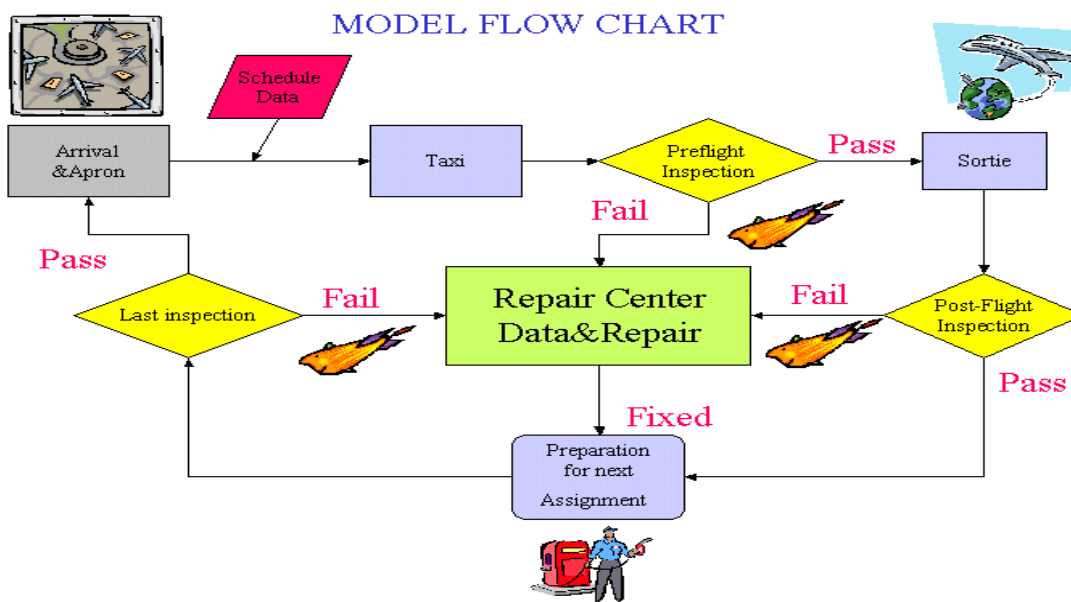

**Figure 11. Model Flow Chart**

The model begins with the arrival of the required equipment to the FOL. For this model 12 F16CJ, 12 F15C, and 12 F5E aircraft are considered. The model sortie generation is driven by the schedule used in O’Fearna (1999). The aircraft types and

quantities depend upon the schedule. The aircraft assignments to the sorties, however, are done with the first available aircraft for every type of aircraft. Each Aircraft leaves the apron area separately and taxi to the runway for pre-flight inspections.

In the first inspection, if the aircraft individually passes the inspection, it waits to be paired to fly an assigned mission. A scheduled mission is cancelled if two aircraft cannot be paired within 30 minutes of the scheduled mission time. Once paired, and if within the mission window, the aircraft fly the assigned mission.

Any aircraft that fail inspection move to the repair center. Failures arise in pre-flight, post-flight, and in post-repair inspections. The repair center is the one of the primary sections of this model. The repair center is activated when an aircraft enters and requires some repair. VBA modules read and assign the data related to the failures using Work Unit Code (WUC) and Action Taken (AT) codes. The VBA modules also determine the time and the types and quantities of AGE for repairing the failures. The AGE quantity based on current usage regulations, analysis and can change for different scenarios. Repairs can begin when all required AGE is available. The aircraft leaves the repair center once all of its failures are fixed. Each aircraft may have multiple failures.

All mission-capable aircraft enter pre-flight where loading and preparations begin. Once all service is completed one last inspection is performed to check if aircraft has any failure or if it is ready to go. An aircraft failing this inspection returns to the repair center, otherwise, it is ready for its mission.

The assumptions related to the model given below are accepted to simplify the model environment, sometimes ignore activities beyond the model scope, and sometimes limit the resources assessed.

The key assumptions are:

- The model simulates 7-days, 10080 minutes.
- All aircraft and AGE arrives at 0 time.
- All aircraft and AGE arrive in fully operational conditions.
- Baseline force numbers are 12-F16CJ for SEAD, 12-F15C for Air Superiority, 12-F15E for Ground Attack.
- The schedule is based on O’Fearna (1999) (Appendix B).
- All aircraft wait until departure times on the apron.
- The sorties can be completed if required type and number of aircraft are available within 30 minutes of scheduled departure.
- An aircraft can experience between 1 and 3 failures at a time.
- Aircraft are served by AGE using a first come first serve rule.
- Repairs begin when the required AGE type and quantity are available.
- In the case of multiple failures, failures are considered in order.
- For the aircraft, all repair activities are considered at the organizational level. There will be no waiting for parts and no sending parts back to the depot maintenance shop.
- Scheduled maintenance is ignored for the seven-day period.
- Personnel, maintenance crews, pilots, transportation vehicles, fuel, spare parts are not modeled resources so are considered unlimited resource.
- AGE/ MASS breaks are not modeled for 7-days period.
- MASS modules loading and travel times are included in the repair times, so excluded from the model.
- All types of aircrafts share AGE units deployed.
- Aircraft are assigned to the sorties by type and first availability, not by tail numbers.

- Aircraft leave the repair center when fully fixed.

**The Input Data and Related Issues**

This thesis assesses the impacts of the substitution of AGE with MASS. The target is to achieve the planned sorties with a given number of AGE and after substitution achieve the same rates with smaller footprint. “The model is constructed with the data from different agencies, like Air Force Scientific Advisory Board, Armstrong Laboratory, the AEF Battle lab at Mt. Home Air Force Base” (O’Fearn, 1999:51).

The data is used generally obtained from Festejo (2000) and O’Fearn (1999). Current deployment levels (baseline) for AGE given in Table 1. These values are taken as a beginning point for analysis AGE numbers. “The AGE deployment levels were obtained from F-16 and F-15 SPO from Mt. Home AFB” (O’Fearn, 1999:54).

The aircraft leave the apron for their missions, depending on the schedule given in Appendix B. The aircraft taxi to the runway for the first inspection. The taxi period is accepted as a 15-minute delay in the model. For the first inspection, pre-flight inspection, the aircraft can fail on the ground with the Abort Rates given in Table 2. “The percentage of Total Abort Rate and Total Break Rate for each aircraft type is taken from ACC published control limits for logistics standards, averages, and goals” (O’Fearn, 1999:47).

**Table 1. Current Deployment Levels of AGE for AEFs**

<b>AGE</b>	<b>Baseline AGE</b>
AM32A-60A GENERATOR	13
AM32C-10C AIR CYCLE COOLING	13
TTU-228 1-B HYDRAULICS TEST STAND	3
MC-1A HIGH PRESSURE AIR COMPRESSOR	0
MC-2A LOW PRESSURE AIR COMPRESSOR	5
NG-02 NITROGEN SYLINDER	0

**Table 2. Aircraft Abort Rate on the Ground**

F16CJ	F15C	F15E
5%	5%	5%

As aircraft pass inspection, they wait to be paired for the mission and receive a go for the sortie. “The sortie duration data was obtained from Operations Squadrons at Mt. Home Air Force Base (AFB)” (O’Fearn, 1999:46). Unless mentioned otherwise, the mission durations are modeled in this thesis as a triangular distribution with parameters given in Table 3.

As aircraft complete their mission, they are individually inspected for breaks during the flights. The break rates are similar to Festejo’s (2000) data. O’Fearn (1999) used half of these values for break rates. Post-flight inspection decides whether the aircraft returned from mission with failures or not. The break rates for each type of aircraft are given in Table 4.

**Table 3. Aircraft Sortie Duration Data from Mt. Home AFB**

Level	F16CJ	F15C	F15E
Minimum	2.1hrs	2.2hrs	2.3hrs
Average	2.7hrs	2.7hrs	2.5hrs
Maximum	3.3hrs	3.2hrs	3.3hrs

**Table 4. The Break Rates for Post-flight Inspection**

F16CJ	F15C	F15E
20%	34%	24%

For aircraft that return from the flight without failure, the loading/preparation begins. This implies the aircraft can make a quick-turn for the next assignment. The quick-turn times for loading/preparation are given in Table 5 and are modeled as a triangular distribution.

**Table 5. Quick-turn Times for the Aircrafts without failure**

Levels	F16CJ	F15C	F15E
Minimum	45min	45min	45min
Average	55min	55min	55min
Maximum	65min	65min	65min

For any aircrafts failures, the numbers of failures assigned to the aircraft is given in Table 6.

**Table 6. The Percentages Related to the Number of Failures**

1FAIL	2FAIL	3FAIL
33.33%	33.33%	33.33%

The AGE travel time from the shop to the requesting aircraft is modeled as a triangular distribution and given in Table 7. These travel times are one-way only as return times to shops are considered part of repair times. The loading times of the component modules are included in the travel times for MASS units.

**Table 7. The Travel Times for AGE**

<b>Levels</b>	<b>LowTravelTime</b>	<b>CenterTravelTime</b>	<b>HighTravelTime</b>
<b>Minimum</b>	5min	15min	30min
<b>Average</b>	15min	30min	45min
<b>Maximum</b>	30min	45min	60min

The loading, preparation and inspection times are modeled as a triangular variable and given in Table 8.

**Table 8. Last Inspection/Loading/Preparation Data**

<b>Levels</b>	<b>F16CJ</b>	<b>F15C</b>	<b>F15E</b>
<b>Minimum</b>	60min	60min	60min
<b>Average</b>	90min	90min	90min
<b>Maximum</b>	150min	150min	150min

The inspection failure rates for aircraft in the last inspection are presented in Table 9.

**Table 9. The Last Inspection and Servicing Failure Rates for Aircraft Types**

<b>F16CJ</b>	<b>F15C</b>	<b>F15E</b>
2%	2%	2%

The failure data are used, “provided by the analysis shop (366 OSS/OSOA) at Mountain Home AFB for the calendar year 1998. This data came from a single source. However, these data does not reflect fleet wide maintenance actions, just Mt. Home AFB



data” (O’Fearn, 1999:52). The data are sufficiently representative for use in this research.

The comparison of the footprint covers the AGE and their MASS equivalences used in the model. Other powered or non-powered AGE, personnel or support materials are out of our interest and not counted. The AGE models and their equivalences as MASS modules used in this model are displayed in Table 10 and 11.

**Table 10. Equivalent AGE and MASS modules for F-16CJ**

AGE	MASS FOR F16CJ
GENERATOR (AM32A-60A)	1 DIESEL GEN. & 1 AVIONICS POWER CONVERTER (APC)
AIR CYCLE COOLING (AM32C-10)	2 AIR COOLING MODULE
HYDRAULICS TEST STAND (TTU-228E)	3 HYDRAULICS MODULE
HIGH PRESSURE AIR COMP (MC-1A)	PNEUMATICS MODULE
LOW PRESSURE AIR COMP (MC-2A)	
NITROGEN CYLINDER (NG-02)	

**Table 11. Equivalent AGE and MASS modules for F-15C/E**

AGE	MASS FOR F15C/E
GENERATOR (AM32A-60A)	1 DIESEL GEN. & 1 AVIONICS POWER CONVERTER (APC)
AIR CYCLE COOLING (AM32C-10)	3 AIR COOLING MODULE
HYDRAULICS TEST STAND (TTU-228E)	4 HYDRAULICS MODULE
HIGH PRESSURE AIR COMP (MC-1A)	PNEUMATICS MODULE
LOW PRESSURE AIR COMP (MC-2A)	
NITROGEN CYLINDER (NG-02)	

Failures are described with “Work Unit Codes” (WUC) and “Action Taken” (AT) codes. The Action Taken codes are presented in Table 12.

**Table 12. Action-Taken Codes used**

F – Repair
J - Calibrated - No Adjustment Required
L – Adjust
R – Remove and Replace
Z - Corrosion Repair
G - Repair or Replace Minor
K - Calibrated - Adjustment Required
P – Removed
V – Cleaned

Some of the failures described with WUC and AT do not require any AGE or MASS. For these failures, the aircraft is delayed in maintenance according to the triangular distributed repair times. “For those that require AGE, maintenance experts at the 389<sup>th</sup>, 390<sup>th</sup>, 391<sup>st</sup> maintenance squadrons determined the AGE required for each WUC at the 3-digit level with consideration of the AT code” (O’Fearn, 1999:53).

Also, the data indicates that some of the AGE is not used for any of the determined failure. All of these issues are taken into consideration either in the model building process or analysis.

## Analysis Methodology

For different purposes, the EAF package is examined and modeled. The simulation model examines 7-days of a deployment scenario. The flight schedule drives aircraft mission and the resulting repair requirements drive AGE utilization. The data obtained is used to determine AGE utilization rates and FSE data defined as the ratio of flight sorties to total planned sorties. While keeping FSE relatively stable, we look for reductions in the quantity of AGE. Also, while keeping FSE relatively stable, we examined replacing AGE with MASS to determine mission impacts. The reductions in AGE and substitutions with MASS give us the opportunity to examine the potential reduction in the deployment footprint due to AGE/MASS.

The Baseline values are obtained from Festejo (2000). These baseline values are the current deployment values. The saturated design is used for finding the reduced values. Then, we begin the screening experiment for within AGE analysis.

The analysis within AGE starts with a  $2_{IV}^{4-1}$  screening experiment, and with 10 replications based on the low and high values given in Table 13.

**Table 13. The Screening Experiment Design Values**

FACTORS	FACTOR LEVELS		
	LOW	CENTER	HIGH
<b>AGE INVENTORY</b>	GEN=7 COOL=6 HYDRA=3 HiP=0 LoP=2 NITRO=0	GEN=13 COOL=13 HYDRA=3 HiP=0 LoP=5 NITRO=0	GEN=75 COOL=75 HYDRA=75 HiP=75 LoP=75 NITRO=75
<b>TRAVEL TIMES DISTRIBUTION</b>	(5,15,30)	(15,30,45)	(30,45,60)
<b>PERIOD SIMULATED</b>	4 days	7 days	10 days
<b>AIRCRAFT NUMBERS</b>	9 each	12 each	15 each

The screening experiment helps to determine the important factors among AGE inventory, travel time, simulation length and aircraft. Important factors are examined in more detail using additional experimental designs.

A response-fitting model is determined using a  $2_{IV}^{8-4}$  fractional factorial design with 100 replications based on the low, center, and high values given in Table 14.

**Table 14. The Response-Fitting Model Values (Aircraft/Simulation time included)**

FACTORS	FACTOR LEVELS		
	LOW	CENTER	HIGH
GEN	6	11	16
COOL	5	9	13
HYDRA	2	5	8
HiP	0	1	2
LoP	2	4	6
NITRO	0	2	4
PERIOD SIMULATED	4 days	7 days	10 days
AIRCRAFT NUMBERS	9 each	12 each	15 each

For AGE types, a two-level quarter fractional factorial design  $2_{IV}^{6-2}$  with 4 center points was run using 100 replications based on the low, center, and high values given in Table 15.

**Table 15. The Response-Fitting Model Values only for AGE**

AGE INVENTORY	FACTOR LEVELS		
	LOW	CENTER	HIGH
GEN	0	8	16
COOL	0	6	12
HYDRA	0	4	8
HiP	0	1	2
LoP	0	3	6
NITRO	0	2	4

We then examine AGE versus MASS and our AGE inventory versus the baseline AGE inventory. These analyses are helpful to determine the improvement percentages in the footprint and to determine the breakpoints to achieve the same FSE rates.

### **Summary**

This chapter began with the explanations of the definition of simulation. Then the reasons for choosing the simulation, ARENA and Excel are examined. The model structure is presented in terms of sub-models, entity flow and detailed model idea. The assumptions are given to explain in what constraints and resources, the model runs. The data used in the model is presented. The other issues like types of equipment, different codes are explained. Further, the methodology in the simulation analysis is detailed before explaining the analysis in chapter 4.

## IV. Results and Analysis

### Introduction

In this chapter, we analyze various scenarios with the AGE models. The impact on FSE is discussed. The FSE is the ratio of successfully completed sorties to planned sorties (for seven days) and is reasonable measure of mission success. The footprint section determines the results related to the reduction gains on footprint of cargo for AEFs.

### Within AGE, Analysis Results

We begin the analysis using a saturated AGE scenario. The information obtained from this scenario give the maximum levels of AGE for the deployment scenario. These numbers are provided in the right-hand column of Table 16. The reduced levels of AGE are given in the center column of Table 16. These reduced levels are later examined to see if FSE rates are maintained (compared to max levels) and footprint reduced.

**Table 16. The Reduced and Maximum AGE Values**

AGE	REDUCED LEVELS	MAXIMUM LEVELS
GENERATOR	7	15
COOLING	6	13
HYDRAULICS	3	8
HIGH PRESS.	1,0	2
LOW PRESS.	2	6
NITROGEN	1,0	5

In the second step, the analyses use screening experiments to examine which factors are important: AGE inventory, aircraft levels, simulation time or travel time. We run a  $2_{IV}^{4-1}$  fractional factorial design. The results indicate that the important factors are AGE numbers, simulation time and aircraft numbers; AGE travel times are not an important influence on FSE. The results of two-level design are given in Appendix C. The two-level design levels correspond to the low and high columns of Table 13. A maximum FSE 98.33% can be achieved. The most important factors are the AGE and aircraft numbers. Logically, as the aircraft inventory increases, we can better achieve a flight schedule and as AGE inventory increases resources are sufficient to keep the aircraft repaired and flying. We also found that FSE is inversely related to the simulation time. As simulated time increases, we see the FSE drop as more failures occur and thus stress the available AGE inventory.

To build a response model of the factors, a  $2_{IV}^{8-4}$  fractional factorial design was run. The full analysis results are given in Appendix D, based on 100 replications at each design point. The results indicate that aircraft numbers, low-pressure air compressor, nitrogen servicing unit and simulation time are the only main factors at the end. Aircraft-cooling, aircraft-low pressure, and aircraft-simulation time are the important interactions. The only quadratic factor is nitrogen. The fitting model is:

$$\hat{y} = 29.32 + 4.87acft + 0.013cool + 0.23lop + 3.46nitro - 0.0008simtime + 0.017acft * cool + 0.54acft * lop - 0.00003acft * simtime - 2.95nitro^2$$

The model R-square is nearly 0.97 so it provides a very good fit of the data.

Figure 12 below shows the various interactions in the model. This model provides an

estimate of FSE when all factors are allowed to vary. Another important model provides estimates of FSE when only AGE levels are allowed to vary.

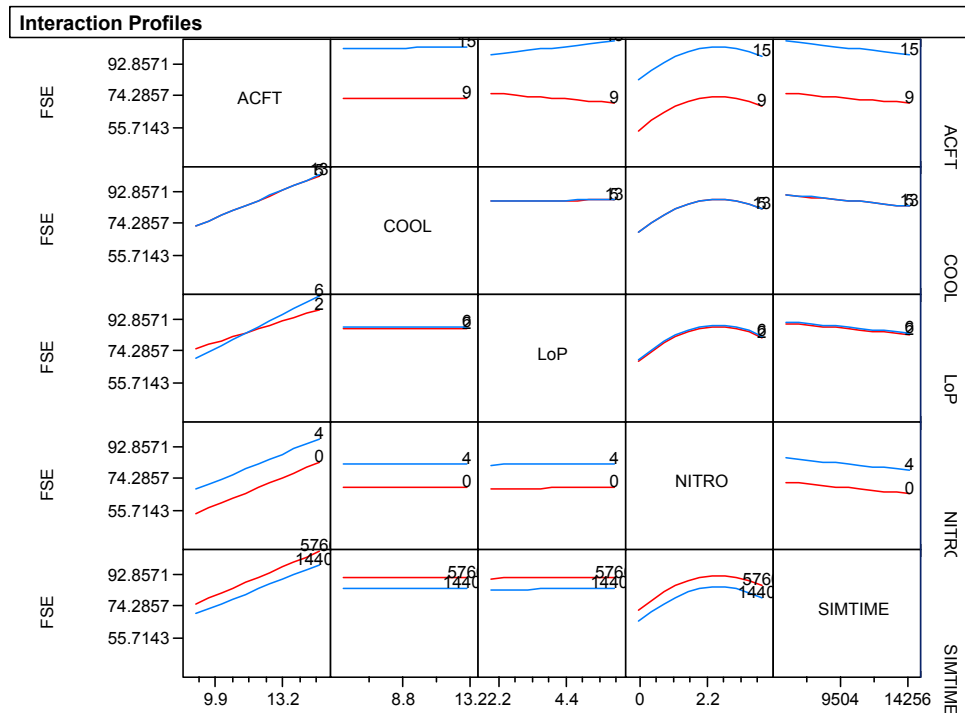

**Figure 12. The Interactions between the Main Factors**

To build a response-fitting model (only AGE types) of the factors, a  $2_{IV}^{6-2}$  fractional factorial design was run. The aircrafts are kept at the deployed level (12) and simulation time is 7-days. The full analysis results are given in Appendix E, based on 100 replications at each design point. The results indicate that all AGE types are important in the model as main factors. The important quadratic term involves the generator. The interactions are given in the model, which is:



$$\hat{y} = 57.07 + 1.23GEN + 1.47COOL + 1.13HYDRA + 0.86HiP + 1.62LoP + 0.95NITRO - 0.86GEN^2 + 0.18GEN * COOL + 0.14GEN * HYDRA + 0.12GEN * HiP + 0.19GEN * LoP + 0.086GEN * NITRO + 0.15COOL * HiP + 0.017GEN * COOL * HiP + 0.28HYDRA * HiP + 0.036GEN * HYDRA * HiP$$

The model R-square is nearly 0.98 so it provides a very good fit of the data.

Figure 13 shows the interaction relations for this analysis. This model provides an estimate of FSE when AGE levels are allowed to vary.

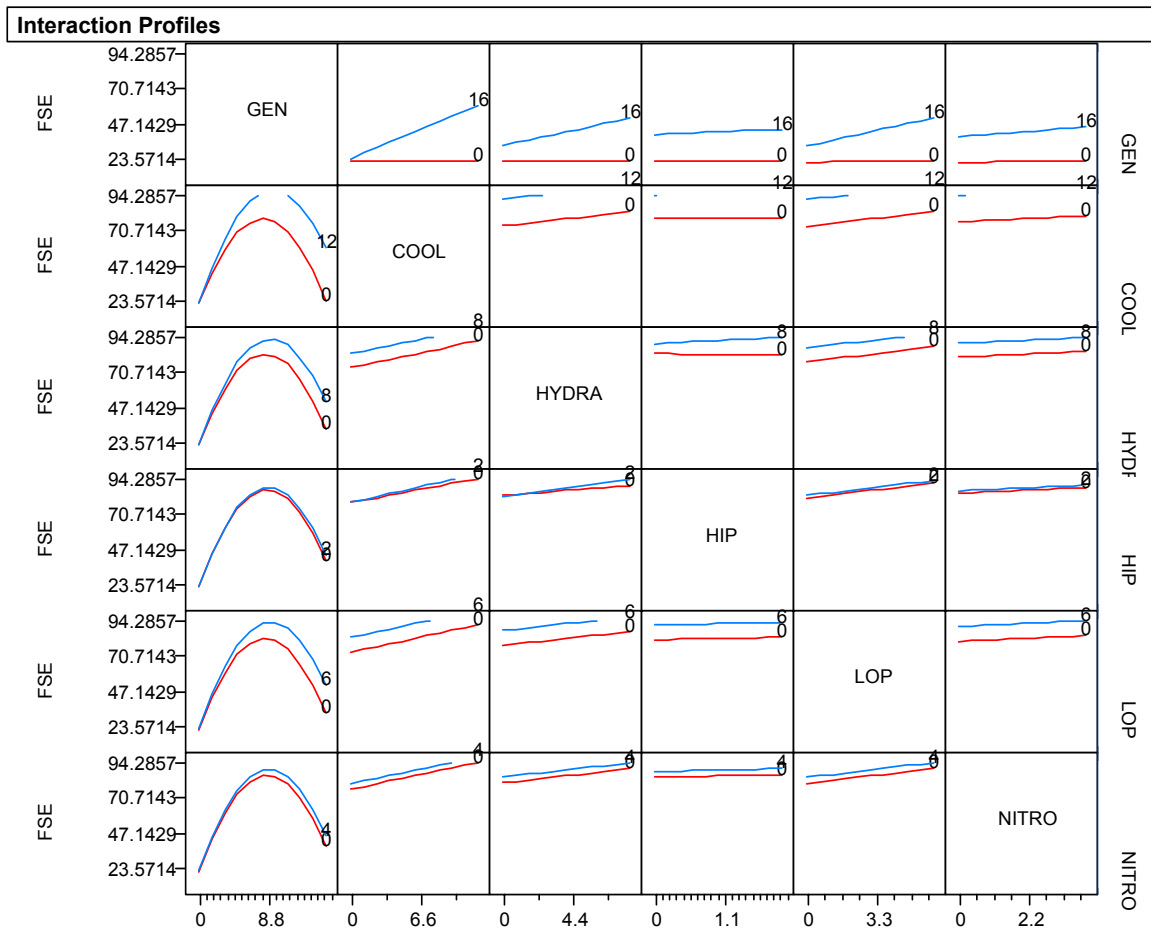

**Figure 13. The Interactions for AGE Response-Fitting Model**

**Between AGE, Analysis Results**

Table 17 summarizes the AGE inventories examined and compared. The rightmost column includes current AGE deployment levels.

**Table 17. The AGE Inventories Examined**

<b>AGE</b>	<b>SATURATED</b>	<b>MAXIMUM</b>	<b>REDUCED</b>	<b>CURRENT</b>
<b>GENERATOR</b>	<b>75</b>	<b>15</b>	<b>7</b>	<b>13</b>
<b>COOLING</b>	<b>75</b>	<b>13</b>	<b>6</b>	<b>13</b>
<b>HYDRAULICS</b>	<b>75</b>	<b>8</b>	<b>3</b>	<b>3</b>
<b>HIGH PRESS.</b>	<b>75</b>	<b>2</b>	<b>1</b>	<b>0</b>
<b>LOW PRESS.</b>	<b>75</b>	<b>6</b>	<b>2</b>	<b>5</b>
<b>NITROGEN</b>	<b>75</b>	<b>5</b>	<b>1</b>	<b>0</b>
<b>MASS</b>	<b>SATURATED</b>	<b>MAXIMUM</b>	<b>REDUCED</b>	<b>CURRENT</b>
<b>GENERATOR</b>	<b>75</b>	<b>16</b>	<b>8</b>	<b>0</b>
<b>COOLING</b>	<b>75</b>	<b>13</b>	<b>6</b>	<b>0</b>
<b>HYDRAULICS</b>	<b>75</b>	<b>10</b>	<b>4</b>	<b>0</b>
<b>APC</b>	<b>75</b>	<b>13</b>	<b>6</b>	<b>0</b>
<b>PNEUMATICS</b>	<b>75</b>	<b>7</b>	<b>3</b>	<b>0</b>
<b>MASS CART</b>	<b>75</b>	<b>16</b>	<b>8</b>	<b>0</b>

We first compare just AGE versus MASS for each level of equipment inventory. The results are provided in Table 18 and note there are no significant differences in FSE between AGE and MASS at any inventory level. This implies MASS does not adversely effect capability despite combining AGE functions. With this table, we can also conclude that we can send the determined numbers of MASS to the theater and reach the FSE expectations without degrading the mission goals. Table 18 shows 95% Confidence intervals for AGE-MASS comparisons. When 95% confidence intervals include 0, this implies that there are no statistically significant differences. “Not significant” in the paired-t column shows the difference significances. Table 18 suggests that we may replace AGE with MASS modules and reach the statistically same FSE rates.

**Table 18. The Mean FSE Rate Comparison between AGE and MASS**

<b>AGE</b>	<b>FSE RATIO</b>	<b>MASS</b>	<b>FSE RATIO</b>	<b>PAIRED-T</b>
<b>SATURATED</b>	87.89795918%	<b>SATURATED</b>	87.72108844%	Not significant
<b>MAXIMUM</b>	87.89965986%	<b>MAXIMUM</b>	87.71938776%	Not significant
<b>REDUCED</b>	87.62585034%	<b>REDUCED</b>	87.87925170%	Not significant

The next comparison is between the current deployment level and the saturated, peak, and reduced AGE levels. The results are given in Table 19. The values are FSE rate and note this time the difference between the inventories. This is largely due to not currently deploying a nitrogen cart or a high-pressure air compressor both of which are needed to fix certain aircraft failures. When these AGE are unavailable the failed aircraft cannot return to flying duty. In our AGE analysis, these items were found important and made a part of the AGE inventory. Table 19 gives the FSE rates for different levels and 95% Confidence intervals results. “Significant” in the paired-t column indicates that the confidence intervals do not include 0.

**Table 19. The Mean FSE Rate Comparison of AGE Current Deployment**

<b>AGE</b>	<b>FSE RATIO</b>	<b>AGE</b>	<b>FSE RATIO</b>	<b>Paired-t</b>
<b>SATURATED</b>	87.89795918%	<b>CURRENT</b>	69.85884354%	Significant
<b>PEAK</b>	87.89965986%	<b>CURRENT</b>	69.85884354%	Significant
<b>REDUCED</b>	87.62585034%	<b>CURRENT</b>	69.85884354%	Significant

Table 19 suggests that instead of current deployment levels we can send the reduced levels determined in this analysis and achieve more FSE rate. The one-way

analysis results and 95% confidence intervals related to AGE/MASS comparison, and the Table 19 are given in Appendix F.

### **The Footprint**

The footprint analysis is performed using the same dimensions used in Festejo (2000) and O’Fearná (1999). The deployment footprint refers to the amount of area, measured in square feet, taken up by MASS modules and its functionally equivalent AGE carts (Festejo, 1999:45). The footprint of the deployed equipment is found by multiplying the dimensions of the each unit by the number sent to the theater. The particular footprint dimensions of each type of AGE and MASS are given in Appendix G. The footprint reduction for every scenario can be seen in Table 20.

**Table 20. The Footprint Comparisons of Each Scenario**

<b>LEVELS</b>	<b>AGE</b>	<b>MASS</b>	<b>CURRENT</b>
<b>MAXIMUM</b>	2367	1200	1753
<b>REDUCED</b>	1053	600	1753

As we can see from Table 20, the analysis suggests hopeful results. The current deployment levels suggest a footprint of 1753 square feet (for our scenario). Even at peak (max) inventory, MASS reduces this footprint significantly. Under reduced AGE and MASS inventories, both realize footprint reductions over current deployment levels, 40% and 65%, respectively.

## **Summary**

This chapter examines the important scenario factors. We first determined that AGE flight line travel time was not an important influence on FSE. We determined that the aircraft number in an AEF could influence FSE as does employment length (simulation time) and the level of AGE inventory deployed.

We examined AGE impacts on FSE at saturated, peak, reduced, and current deployment levels as well as for MASS levels. We determined that we could decrease the AGE inventory without impacting FSE. These AGE reductions could mean a 39.93% footprint reduction. When we replace AGE with MASS, we gained an additional 43% in footprint area, while keeping the similar FSE rate. As a replacement for AGE, MASS is a viable alternative as there is no apparent loss of capability but a sizeable reduction in deployment footprint.

## **V. Conclusions and Recommendations**

### **Introduction**

This chapter summarizes the thesis effort, interprets the results, provides some conclusions and discusses areas of further research.

### **Interpretations**

In this thesis, we chose to look at the deployment strategies for AGE with discrete-event simulation. Concepts like MASS and the EAF are still under development, so many ideas still need clarification. The data used in our model is fairly representative and the analytical model is a reasonable representation.

The US Air Force budget declines, forces are getting smaller, while the complexity of the missions increase with respect to technology and the politics. As the AF becomes more expeditionary, we can no longer afford overly large deployment footprints. The footprint of AGE covers more space in the deployment than many believe it is supposed to. The critics of current deployments indicate that the USAF should decrease deployment footprint immediately. This work provides a quantitative approach using response surface methods to help achieve reduced footprints.

This work assesses the footprint possibilities related to six kinds of AGE and MASS. The possible footprint reductions are the direct target of this research. However, while decreasing the footprint, we are bound by maintaining operational effectiveness as we measured as FSE.

## Conclusions

We determined that simulation time, aircraft numbers, and the AGE types are important factors. Travel times of AGE on the flight line are not as important. We determined that if we increase the AGE number(s) or/and aircraft numbers, we could increase the FSE rate. The simulation time period is found as inversely related to FSE for the 4 to 10 day period examined. In fact, we cannot say anything outside of these limits.

An empirical model is determined. Such a model can be useful for extended “what-if” analyses. Consider a simple spreadsheet with the FSE empirical model embedded. The user can enter AGE inventory values and receive a response FSE rate. Conversely, the model can be used with a Goal Seek feature to forecast AGE inventory values for desired FSE levels.

Next, the analysis results showed that we could reduce the AGE numbers significantly, while retaining the same FSE rate. The footprint reduction related to the current deployment (without substituting MASS) is around 39%. The footprint reduction of replacing MASS with the current deployment level and best AGE level is around 65% and 43%, respectively. FSE rate during these reductions didn’t change.

The contributions of this thesis are:

- The model is re-engineered into ARENA.
- Improved AGE analysis methodology.
- Introduced RSM into methodology.
- Considered inventory sensitivities to deployment force structure and initial deployment period.

## **Recommendations**

Because of the time and expertise limitations, we only include small number of variables. A logical next step is to expand the model to include more AGE types.

The data collection on the related subjects does probably need to continue. The model input data can be reviewed. The model can also be extended further to include other AGE types, aircraft types and numbers and different EAF periods.

The cost analysis of AGE and MASS modules can be added to this analysis to see the long-term or short-term costs. In this thesis effort, we ignored a lot of constraints like the maintenance personnel, fuel, conveyors, pilots ...etc. The model could also be enlarged to include these constraints.



## Appendix A. The Model/Sub-models/VBA Code

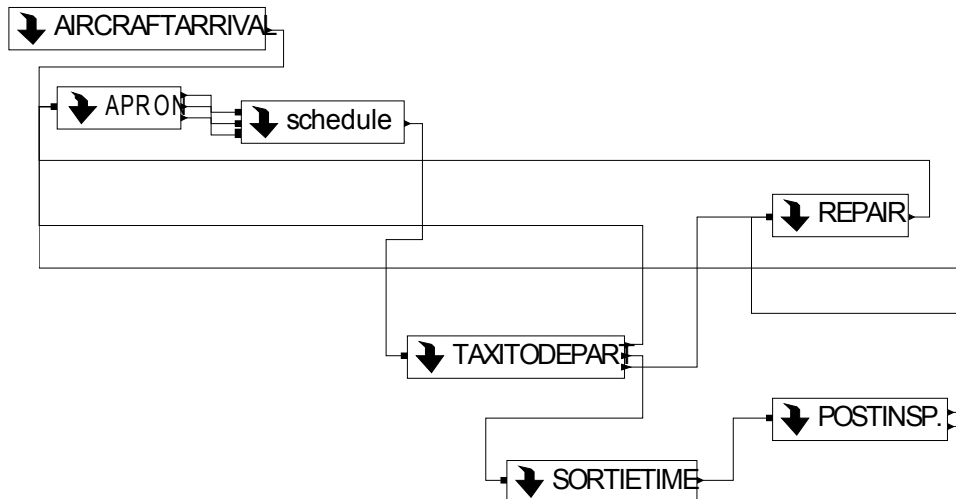

### THE VBA CODE TO READ THE AGE REPAIR DATA

```

Option Explicit
Public sAGEMATRIX As String, INITIAL, REPLICATION, AGE, MASS, ORIGINAL, FSE
Private Sub ModelLogic_RunBeginSimulation()
Dim oSIMAN As Arena.SIMAN
Dim sVariableName As String
Dim nVariableIndex As Long
Dim iRowIndex As Integer
Dim iColumnIndex As Integer
Dim oExcelApp As Excel.Application
Dim oWorkbook As Excel.Workbook
Dim oWorksheet As Excel.Worksheet
Dim oRange As Excel.Range
Dim sRep As Long
Dim sTermtime As Long
Dim sF16CJno As Long
Dim ACFT1 As String
Dim sF15Cno As Long
Dim ACFT2 As String
Dim sF15Eno As Long
Dim ACFT3 As String
Dim sAGEGEN As Long
Dim GEN As String
Dim sAGECOOL As Long
Dim COOL As String
Dim sAGEHYDRA As Long
Dim HYDRA As String
Dim sAGEHiP As Long
Dim HiP As String
Dim sAGELoP As Long
Dim LoP As String
Dim sAGENITRO As Long
Dim NITRO As String
ORIGINAL = 0
AGE = 0
MASS = 0
Const sAGEMATRIX = "C:\LHANKAYA-THESIS\INPUTS\AGE1.xls"
Set oSIMAN = ThisDocument.Model.SIMAN
Set oExcelApp = CreateObject("Excel.Application")
Set oWorkbook = oExcelApp.Workbooks.Open(sAGEMATRIX)
  
```

```

' FIRST USER IS ASKED WHICH TYPE OF AGE IS WANTED TO BE EXAMINED
Dim Response
Response = MsgBox("Do you want the model run with its own values? , IF YES, AGE WILL BE SIMULATED WITH ITS OWN
VALUES", vbYesNo)
If Response = vbYes Then
ORIGINAL = 1
GoTo Line100
ElseIf Response = vbNo Then
End If
Response = InputBox("CHOOSE ONE TYPE OF AGE TO SIMULATE?   (ONLY THE NUMBERS)
SELECT AGE=1,                               SELECT MASS=2")
If Response = "" Then
GoTo Line100
ElseIf Response = 1 Then
GoTo Line100
ElseIf Response = 2 Then
GoTo Line200
ElseIf Response = "" Then
End If
' AGE SIMULATIONS DATA READING FROM EXCEL FILE

Line100:
AGE = 1
Const Sheetname1 = "F15EAGE"
Set oWorksheet = oWorkbook.Worksheets(Sheetname1)
Set oRange = oWorksheet.Range("f15edata")
For iColumnindex = 1 To 11
For iRowindex = 1 To 430
    sVariablename = "FRATE15e"
    nVariableindex = oSIMAN.SymbolNumber(sVariablename, iRowindex, iColumnindex)
    oSIMAN.VariableArrayValue(nVariableindex) = oRange.Cells(iRowindex, iColumnindex)
Next iRowindex
Next iColumnindex

Const Sheetname2 = "F15CAGE"
Set oWorksheet = oWorkbook.Worksheets(Sheetname2)
Set oRange = oWorksheet.Range("f15cdata")
For iColumnindex = 1 To 11
For iRowindex = 1 To 385
    sVariablename = "FRATE15c"
    nVariableindex = oSIMAN.SymbolNumber(sVariablename, iRowindex, iColumnindex)
    oSIMAN.VariableArrayValue(nVariableindex) = oRange.Cells(iRowindex, iColumnindex)
Next iRowindex
Next iColumnindex

Const Sheetname3 = "F16CJAGE"
Set oWorksheet = oWorkbook.Worksheets(Sheetname3)
Set oRange = oWorksheet.Range("f16cjdata")
For iColumnindex = 1 To 11
For iRowindex = 1 To 337
    sVariablename = "FRATE16"
    nVariableindex = oSIMAN.SymbolNumber(sVariablename, iRowindex, iColumnindex)
    oSIMAN.VariableArrayValue(nVariableindex) = oRange.Cells(iRowindex, iColumnindex)
Next iRowindex
Next iColumnindex

GoTo Line300

' MASS SIMULATION DATA READINGS FROM EXCEL FILE
Line200:
MASS = 1
Const Sheetname4 = "F15EMASS"
Set oWorksheet = oWorkbook.Worksheets(Sheetname4)
Set oRange = oWorksheet.Range("f15emass")
For iColumnindex = 1 To 11
For iRowindex = 1 To 430
    sVariablename = "FRATE15e"
    nVariableindex = oSIMAN.SymbolNumber(sVariablename, iRowindex, iColumnindex)

```

```

oSIMAN.VariableArrayValue(nVariableindex) = oRange.Cells(iRowindex, iColumnindex)
Next iRowindex
Next iColumnindex

Const Sheetname5 = "F15CMASS"
Set oWorksheet = oWorkbook.Worksheets(Sheetname5)
Set oRange = oWorksheet.Range("f15cmass")
For iColumnindex = 1 To 11
For iRowindex = 1 To 385
    sVariablename = "FRATE15c"
    nVariableindex = oSIMAN.SymbolNumber(sVariablename, iRowindex, iColumnindex)
    oSIMAN.VariableArrayValue(nVariableindex) = oRange.Cells(iRowindex, iColumnindex)
Next iRowindex
Next iColumnindex

Const Sheetname6 = "F16CJMASS"
Set oWorksheet = oWorkbook.Worksheets(Sheetname6)
Set oRange = oWorksheet.Range("f16cjmass")
For iColumnindex = 1 To 11
For iRowindex = 1 To 337
    sVariablename = "FRATE16"
    nVariableindex = oSIMAN.SymbolNumber(sVariablename, iRowindex, iColumnindex)
    oSIMAN.VariableArrayValue(nVariableindex) = oRange.Cells(iRowindex, iColumnindex)
Next iRowindex
Next iColumnindex

Line300:
oExcelApp.DisplayAlerts = False
oExcelApp.Quit
Set oWorksheet = Nothing
Set oWorkbook = Nothing
Set oExcelApp = Nothing
If ORIGINAL = 1 Then
GoTo Line10
End If
'AFTER NOW THE DATA IS ASKED FROM USER
'FIRST ASK IF USER WANT TO ENTER ANY NEW VALUE THEN ASK AIRCRAFT NUMBERS SENT TO THE REGION IF
YES
    If MASS = 1 Then
        sAGEGEN = oSIMAN.SymbolNumber("genavailable1")
        oSIMAN.VariableArrayValue(sAGEGEN) = 13
        sAGECOOL = oSIMAN.SymbolNumber("coolavailable1")
        oSIMAN.VariableArrayValue(sAGECOOL) = 20
        sAGEHYDRA = oSIMAN.SymbolNumber("hydravailable1")
        oSIMAN.VariableArrayValue(sAGEHYDRA) = 9
        sAGEHiP = oSIMAN.SymbolNumber("hipresavailable1")
        oSIMAN.VariableArrayValue(sAGEHiP) = 13
        sAGELoP = oSIMAN.SymbolNumber("lowpresavailable1")
        oSIMAN.VariableArrayValue(sAGELoP) = 10
        sAGENITRO = oSIMAN.SymbolNumber("nitroavailable1")
        oSIMAN.VariableArrayValue(sAGENITRO) = 6
    End If
Line:
If AGE = 1 Then
Response = InputBox("Choose related numbers to change data given with initial values, as only numbers,
REPLICATION=1 choose 1,SIM.TIME=10080 choose 2, ACFT F16CJ=12 choose 3, ACFT F15C=12 choose 4, ACFT F15E=12
choose 5, GENERATOR=13 choose 6, COOLING=13 choose 7, HYDRAULICS=3 choose 8, HIGH PRES=0 choose 9, LOW
PRES=5 choose 10, NITROGEN=0 choose 11, MINTTIME=5 choose 12, AVETTIME=15 choose 13, MAXTTIME=30 choose 14,
To End press OKEY or enter 0")
ElseIf MASS = 1 Then

Response = InputBox("Choose related numbers to change data given with initial values, as only numbers,
REPLICATION=1 choose 1,SIM.TIME=10080 choose 2, ACFT F16CJ=12 choose 3, ACFT F15C=12 choose 4, ACFT F15E=12
choose 5, DG MODULE=13 choose 6, AC MODULE=20 choose 7, HYDRAULICS=9 choose 8, MASS CART=13 choose 9, APC
MODULE=10 choose 10, PN MODULE=6 choose 11, MINTTIME=5 choose 12, AVETTIME=15 choose 13, MAXTTIME=30
choose 14, To End press OKEY or enter 0")
End If
If Response = "" Then

```

```

GoTo Line10
Elseif Response = 0 Then
GoTo Line10
Elseif Response = 1 Then
GoTo Line0
Elseif Response = 2 Then
GoTo Line01
Elseif Response = 3 Then
GoTo Line1
Elseif Response = 4 Then
GoTo Line2
Elseif Response = 5 Then
GoTo Line3
Elseif Response = 6 Then
GoTo Line4
Elseif Response = 7 Then
GoTo Line5
Elseif Response = 8 Then
GoTo Line6
Elseif Response = 9 Then
GoTo Line7
Elseif Response = 10 Then
GoTo Line8
Elseif Response = 11 Then
GoTo Line9
Elseif Response = 12 Then
GoTo Line11
Elseif Response = 13 Then
GoTo Line12
Elseif Response = 14 Then
GoTo Line13
End If
Line0:
Response = InputBox("How many replication do you want to run?", "Initial Value=1")
If Response = "" Then
    Response = MsgBox("Do you want to re-enter REPLICATION number?", vbYesNo)
    If Response = vbYes Then
        GoTo Line0
    Else
        GoTo Line01
    End If
Else
sRep = oSIMAN.SymbolNumber("REP_NO")
oSIMAN.VariableArrayValue(sRep) = Response
End If
GoTo Line
Line01:
Response = InputBox("Do you want to enter SIMULATION TIME?", "Initial Value=10080")
If Response = "" Then
    Response = MsgBox("Do you want to re-enter SIMULATION TIME?", vbYesNo)
    If Response = vbYes Then
        GoTo Line01
    Else
        GoTo Line1
    End If
Else
sTermtime = oSIMAN.SymbolNumber("TERM_TIME")
oSIMAN.VariableArrayValue(sTermtime) = Response
End If
GoTo Line

Line1:
ACFT1 = InputBox("Enter the F16CJ Aircraft number sent in AEF as integer, ONLY NUMBERS,MAX=25", "INITIAL
VALUE=12")
If ACFT1 = "" Then
Response = MsgBox("Do you want to re-enter F16CJ number?", vbYesNo)
    If Response = vbYes Then
        GoTo Line1

```

```

Else
GoTo Line2
End If
Else
sF16CJno = oSIMAN.SymbolNumber("F16CJACFT")
oSIMAN.VariableArrayValue(sF16CJno) = ACFT1
End If
GoTo Line
Line2:
ACFT2 = InputBox("Enter the F15C Aircraft number sent in AEF as integer, ONLY NUMBERS,MAX=25", "INITIAL
VALUE=12")
If ACFT2 = "" Then
Response = MsgBox("Do you want to re-enter F15C number?", vbYesNo)
If Response = vbYes Then
GoTo Line2
Else
GoTo Line3
End If
Else
sF15Cno = oSIMAN.SymbolNumber("F15CACFT")
oSIMAN.VariableArrayValue(sF15Cno) = ACFT2
End If
GoTo Line
Line3:
ACFT3 = InputBox("Enter the F15E Aircraft number sent in AEF as integer, ONLY NUMBERS,MAX=25", "INITIAL VALUE=12")
If ACFT3 = "" Then
Response = MsgBox("Do you want to re-enter F15E number?", vbYesNo)
If Response = vbYes Then
GoTo Line3
Else
End If
Else
sF15Eno = oSIMAN.SymbolNumber("F15EACFT")
oSIMAN.VariableArrayValue(sF15Eno) = ACFT3
End If
GoTo Line
'SECOND AGE NUMBERS FOR SIX AGE TYPES

Line4:
If AGE = 1 Then
GEN = InputBox("Enter THE GENERATOR AGE number sent with AEF as integer, ONLY NUMBERS", "INITIAL VALUE=13")
ElseIf MASS = 1 Then
GEN = InputBox("Enter THE DIESEL GENERATOR MASS MODULE number sent with AEF as integer, ONLY NUMBERS",
"INITIAL VALUE=13")
End If
If GEN = "" Then
Response = MsgBox("Do you want to re-enter GENERATOR number?", vbYesNo)
If Response = vbYes Then
GoTo Line4
Else
GoTo Line5
End If
Else
sAGEGEN = oSIMAN.SymbolNumber("genavailable1")
oSIMAN.VariableArrayValue(sAGEGEN) = GEN
End If
GoTo Line
Line5:
If AGE = 1 Then
COOL = InputBox("Enter THE COOLING AGE number sent with AEF as integer, ONLY NUMBERS", "INITIAL VALUE=13")
ElseIf MASS = 1 Then
COOL = InputBox("Enter THE AC MASS MODULE number sent with AEF as integer, ONLY NUMBERS", "INITIAL
VALUE=20")
End If
If COOL = "" Then
Response = MsgBox("Do you want to re-enter COOLING number?", vbYesNo)
If Response = vbYes Then
GoTo Line5

```

```

Else
GoTo Line6
End If
Else
sAGECOOL = oSIMAN.SymbolNumber("coolavailable1")
oSIMAN.VariableArrayValue(sAGECOOL) = COOL
End If
GoTo Line
Line6:
If AGE = 1 Then
HYDRA = InputBox("Enter THE HYDRAULICS number sent with AEF as integer, ONLY NUMBERS", "INITIAL VALUE=3")
ElseIf MASS = 1 Then
HYDRA = InputBox("Enter THE HYDRAULICS MASS MODULE number sent with AEF as integer, ONLY NUMBERS",
"INITIAL VALUE=9")
End If
If HYDRA = "" Then
Response = MsgBox("Do you want to re-enter HYDRAULICS number?", vbYesNo)
If Response = vbYes Then
GoTo Line6
Else
GoTo Line7
End If
Else
sAGEHYDRA = oSIMAN.SymbolNumber("hydravailable1")
oSIMAN.VariableArrayValue(sAGEHYDRA) = HYDRA
End If
GoTo Line
Line7:
If AGE = 1 Then
HiP = InputBox("Enter THE HIGH PRESSURE AGE number sent with AEF as integer, ONLY NUMBERS", "INITIAL VALUE=0")
ElseIf MASS = 1 Then
HiP = InputBox("Enter THE MASS CART number sent with AEF as integer, ONLY NUMBERS", "INITIAL VALUE=13")
End If
If HiP = "" Then
Response = MsgBox("Do you want to re-enter HIGH PRESSURE number?", vbYesNo)
If Response = vbYes Then
GoTo Line7
Else
GoTo Line8
End If
Else
sAGEHiP = oSIMAN.SymbolNumber("hipresavailable1")
oSIMAN.VariableArrayValue(sAGEHiP) = HiP
End If
GoTo Line
Line8:
If AGE = 1 Then
LoP = InputBox("Enter THE LOW PRESSURE AGE number sent with AEF as integer, ONLY NUMBERS", "INITIAL VALUE=5")
ElseIf MASS = 1 Then
LoP = InputBox("Enter THE AVIONICS POWER CONVERTER MASS MODULE number sent with AEF as integer, ONLY
NUMBERS", "INITIAL VALUE=10")
End If
If LoP = "" Then
Response = MsgBox("Do you want to re-enter LOW PRESSURE number?", vbYesNo)
If Response = vbYes Then
GoTo Line8
Else
GoTo Line9
End If
Else
sAGELoP = oSIMAN.SymbolNumber("lowpresavailable1")
oSIMAN.VariableArrayValue(sAGELoP) = LoP
End If
GoTo Line

Line9:
If AGE = 1 Then
NITRO = InputBox("Enter THE NITROGEN AGE number sent with AEF as integer, ONLY NUMBERS", "INITIAL VALUE=0")

```

```

ElseIf MASS = 1 Then
NITRO = InputBox("Enter THE PNEUMATICS MASS MODULE number sent with AEF as integer, ONLY NUMBERS", "INITIAL
VALUE=6")
End If
If NITRO = "" Then
Response = MsgBox("Do you want to re-enter NITROGEN number?", vbYesNo)
    If Response = vbYes Then
        GoTo Line9
    Else
        End If
Else
sAGENITRO = oSIMAN.SymbolNumber("nitroavailable1")
oSIMAN.VariableArrayValue(sAGENITRO) = NITRO
End If
GoTo Line
' THIRD THE TRAVEL TIMES FOR AGE ARE ASKED

Dim sTTMIN As Long
Dim MIN As String
Dim sTTAVE As Long
Dim AVE As String
Dim sTTMAX As Long
Dim MAX As String

Line11:
MIN = InputBox("Enter THE MINIMUM TRAVEL TIME OF AGE as integer, ONLY NUMBERS", "INITIAL VALUE=5")
If MIN = "" Then
Response = MsgBox("Do you want to re-enter MINIMUM TRAVEL TIME?", vbYesNo)
    If Response = vbYes Then
        GoTo Line11
    Else
        GoTo Line12
    End If
Else
sTTMIN = oSIMAN.SymbolNumber("TRAVELTIME1")
oSIMAN.VariableArrayValue(sTTMIN) = MIN
End If
GoTo Line
Line12:
AVE = InputBox("Enter THE AVERAGE TRAVEL TIME OF AGE as integer, ONLY NUMBERS", "INITIAL VALUE=15")
If AVE = "" Then
Response = MsgBox("Do you want to re-enter AVERAGE TRAVEL TIME?", vbYesNo)
    If Response = vbYes Then
        GoTo Line12
    Else
        GoTo Line13
    End If
Else
sTTAVE = oSIMAN.SymbolNumber("TRAVELTIME2")
oSIMAN.VariableArrayValue(sTTAVE) = AVE
End If
GoTo Line
Line13:
MAX = InputBox("Enter THE MAXIMUM TRAVEL TIME as integer, ONLY NUMBERS", "INITIAL VALUE=30")
If MAX = "" Then
Response = MsgBox("Do you want to re-enter MAXIMUM TRAVEL TIME?", vbYesNo)
    If Response = vbYes Then
        GoTo Line13
    Else
        End If
Else
sTTMAX = oSIMAN.SymbolNumber("TRAVELTIME3")
oSIMAN.VariableArrayValue(sTTMAX) = MAX
End If
GoTo Line

Line10:
End Sub

```

## Appendix B. Schedule of The Sorties and The Number of Aircrafts

Table B1. The schedule of the aircrafts in the model

Turn	Go	Time	# ACFT	time	# ACFT	time	# ACFT	time	
1	1	5:00	4	300.00					
	2	5:10			4	310.00			
	3	5:20					4	320.00	
	4	5:45	4	345.00					
	5	5:55			4	355.00			
	6	6:05					4	365.00	
2	1	8:45	4	525.00					
	2	8:55			4	535.00			
	3	9:05					4	545.00	
	4	9:30	4	570.00					
	5	9:40			4	580.00			
	6	9:50					4	590.00	
3	1	12:20	4	740.00					
	2	12:30			4	750.00			
	3	12:40					4	760.00	
	4	13:05	2	785.00					
	5	13:15			2	795.00			
	6	13:25					2	805.00	
4	1	16:05	4	965.00					
	2	16:15			4	975.00			
	3	16:25					4	985.00	
	4	16:50	2	1010.00					
	5	17:00			2	1020.00			
	6	17:10					2	1030.00	SUM
Total daily sorties:			28		28		28		84
Total daily Go's:			8		8		8		24
Total 7-day sorties:			196		196		196		588
Total 7-day Go's:			56		56		56		168
Total 2-ship flights:			98		98		98		294

The schedule table shows the aircraft types and numbers for assigned duties. The times are converted to minutes. For every next day, we add 1440 minutes to the determined minutes. Under the table, the summations are given, for other than 7 days, day quantity is multiplied to the daily sums.



### Appendix C. Within AGE Analysis/Surface Screening 2 LEVEL

Analysis of Variance				
Source	DF	Sum of Squares	Mean Square	F Ratio
Model	7	24425.515	3489.36	461.0036
Error	72	544.972	7.57	Prob > F
C. Total	79	24970.487		<.0001

ANOVA table has a significant small value. This implies that model fits well.

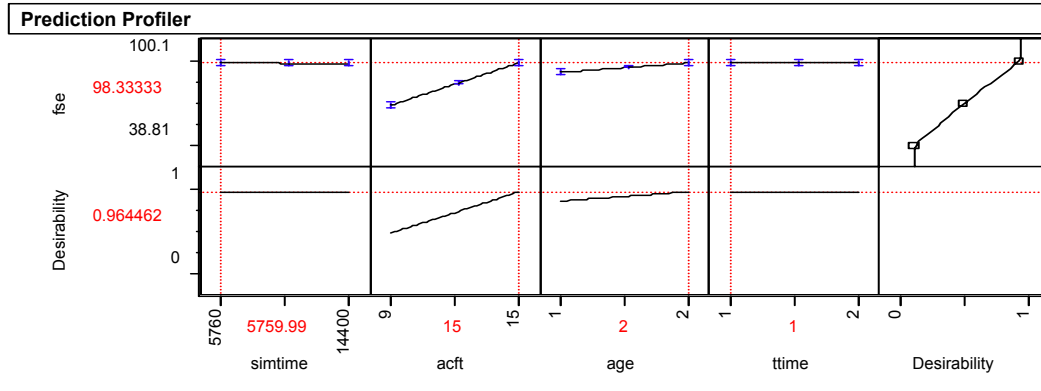

Parameter Estimate Population				
Term	Original	Orthog Coded	Orthog t-Test	Prob> t
Intercept	2.10317	75.97321	246.9931	<.0001
simtime	-0.00080	-3.46131	-11.2529	<.0001
acft	5.00893	15.02679	48.8529	<.0001
age	14.66071	7.33036	23.8314	<.0001
ttime	-0.10119	-0.05060	-0.1645	0.8698
(simtime-10080)*(acft-12)	-0.00004	-0.47917	-1.5578	0.1237
(simtime-10080)*(age-1.5)	0.00170	3.66964	11.9302	<.0001
(acft-12)*(age-1.5)	-0.21230	-0.31845	-1.0353	0.3040

Parameter Estimate Population and Normal plot below determines the significant factors as simulation time, aircraft numbers and AGE numbers as main factors and simulation time-aircraft and simulation time-AGE as important interactions.

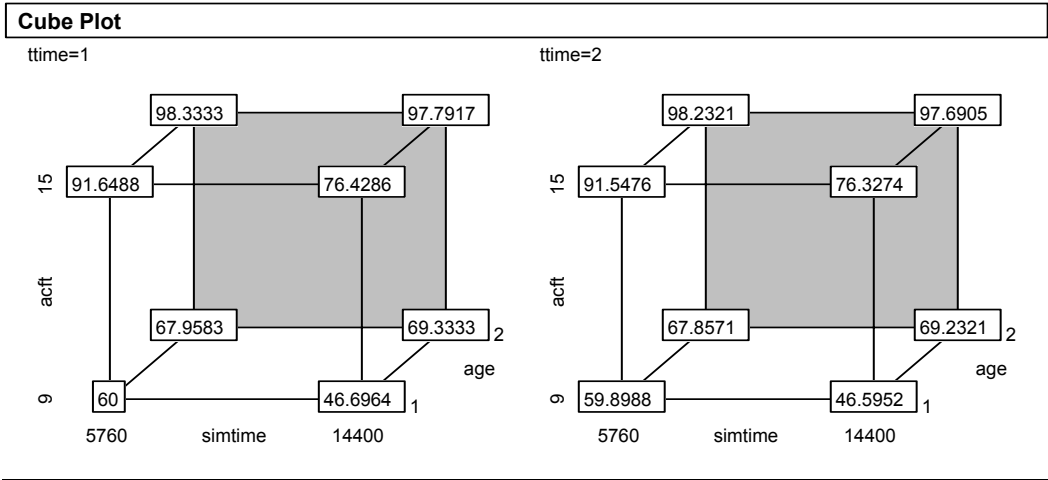
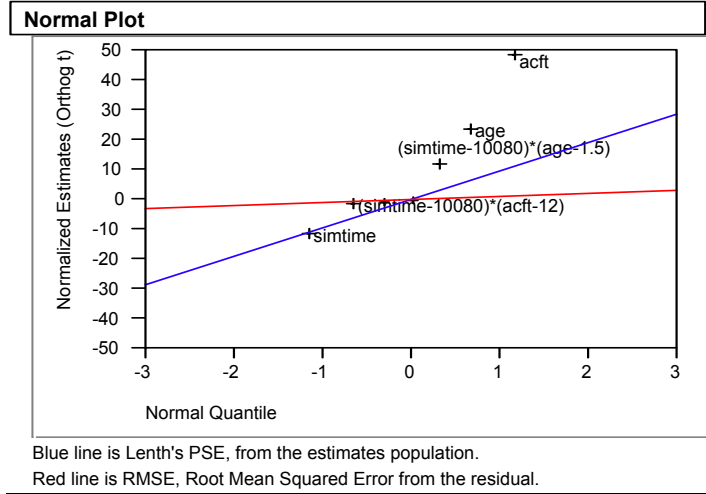

Cube plot shows the possible responses for different combinations of main factors. The maximum response is when simulation time=5760, aircraft=15, and AGE=maximum.

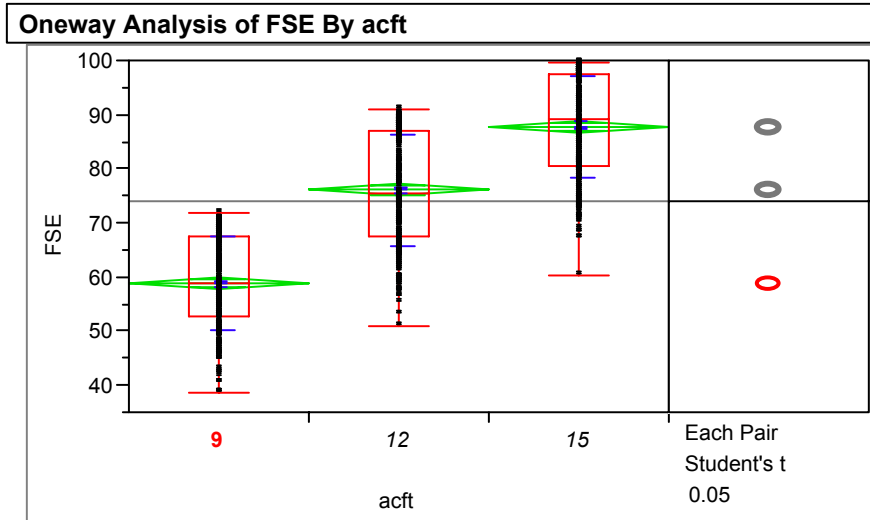

**Oneway Anova**

**Means Comparisons**

Dif=Mean[i]-Mean[j]

	15	12	9
15	0.0000	11.6645	28.9160
12	-11.6645	0.0000	17.2515
9	-28.9160	-17.2515	0.0000

Alpha= 0.05

Comparisons for each pair using Student's t

	15	12	9
t	1.96291		
Abs(Dif)-LSD			
15	-1.5923	10.0722	27.3237
12	10.0722	-1.5923	15.6592
9	27.3237	15.6592	-1.5923

Positive values show pairs of means that are significantly different.

One-way analysis plot for aircraft indicates that the FSE rate increases when aircraft numbers increase. Also, the mean differences between aircraft levels are significantly different.

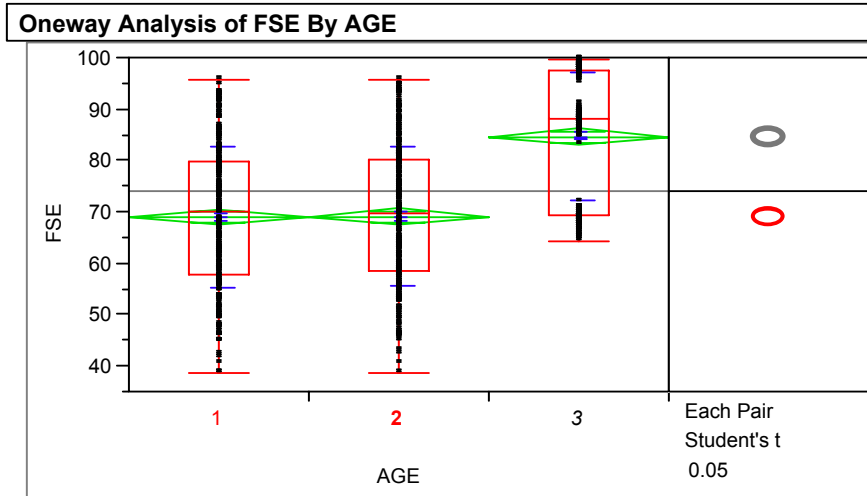

**Oneway Anova**

**Means Comparisons**

Dif=Mean[i]-Mean[j]

	3	2	1
3	0.0000	15.5140	15.6567
2	-15.5140	0.0000	0.1427
1	-15.6567	-0.1427	0.0000

Alpha= 0.05

Comparisons for each pair using Student's t

t

1.96291

Abs(Dif)-LSD

	3	2	1
3	-2.2429	13.2711	13.4138
2	13.2711	-2.2429	-2.1002
1	13.4138	-2.1002	-2.2429

Positive values show pairs of means that are significantly different.

One-way analysis for AGE indicates that the mean difference between saturated level and current and reduced level is significant. However, the mean differences between current and reduced level is not significant. But the reduced level is used with some factors in 0. To increase FSE rate, we have to analyze the levels of AGE type.

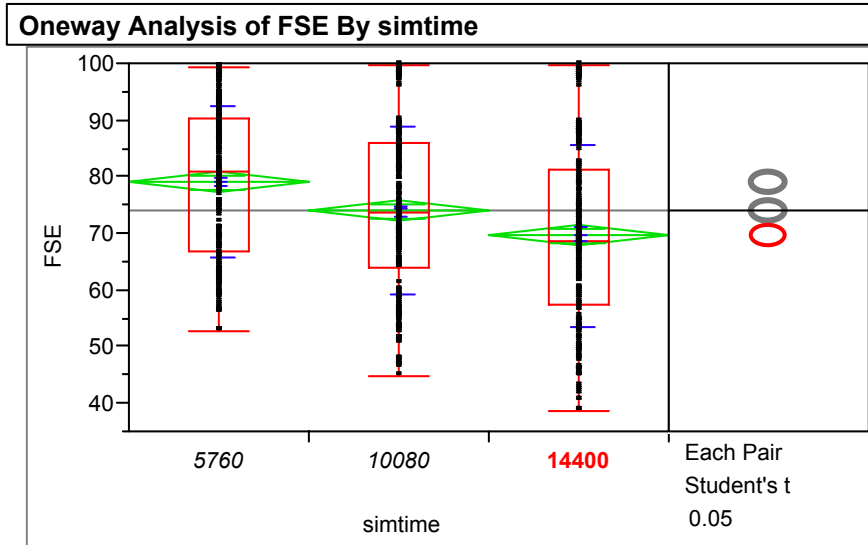

**Means Comparisons**

Dif=Mean[i]-Mean[j]	5760	10080	14400
5760	0.00000	5.07653	9.39903
10080	-5.07653	0.00000	4.32250
14400	-9.39903	-4.32250	0.00000

Alpha= 0.05

Comparisons for each pair using Student's t

Abs(Dif)-LSD	5760	10080	14400
5760	-2.48081	2.59572	6.91822
10080	2.59572	-2.48081	1.84169
14400	6.91822	1.84169	-2.48081

Positive values show pairs of means that are significantly different.

One-way analysis for simulation time indicates when we decrease the period of analysis FSE rate increases, because the cumulative failure probabilities decrease. Also this plot implies that the mean differences between simulation time levels are significant.

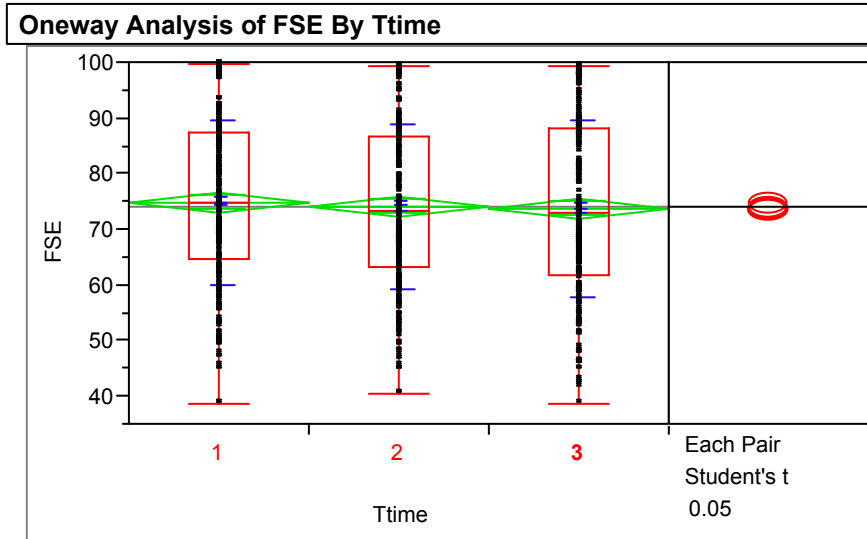

**Means Comparisons**

Dif=Mean[i]-Mean[j]

	1	2	3
1	0.00000	0.69073	1.03691
2	-0.69073	0.00000	0.34618
3	-1.03691	-0.34618	0.00000

Alpha= 0.05

Comparisons for each pair using Student's t

	1	2	3
t			
1.96291			
Abs(Dif)-LSD			
1	-2.56355	-1.87282	-1.52664
2	-1.87282	-2.56355	-2.21736
3	-1.52664	-2.21736	-2.56355

Positive values show pairs of means that are significantly different.

One-way analysis for travel times of AGE indicates, there is no difference between the means. The travel time is not an important factor for FSE rate.

## Appendix D. Within AGE Analysis/Fitting Model

### Response FSE

#### Summary of Fit

RSquare	0.968486
RSquare Adj	0.968344
Root Mean Square Error	2.850199
Mean of Response	78.4427
Observations (or Sum Wgts)	2000

#### Analysis of Variance

Source	DF	Sum of Squares	Mean Square	F Ratio
Model	9	496817.04	55201.9	6795.221
Error	1990	16166.03	8.1	Prob > F
C. Total	1999	512983.07		0.0000

#### Lack Of Fit

Source	DF	Sum of Squares	Mean Square	F Ratio
Lack Of Fit	7	53.295	7.61360	0.9370
Pure Error	1983	16112.738	8.12544	Prob > F
Total Error	1990	16166.034		0.4765
				Max RSq
				0.9686

#### Parameter Estimates

Term	Estimate	Std Error	t Ratio	Prob> t
Intercept	29.323478	0.424592	69.06	0.0000
ACFT	4.8644841	0.023752	204.81	0.0000
COOL	0.0124628	0.017814	0.70	0.4842
LoP	0.2264881	0.035627	6.36	<.0001
NITRO	3.4594494	0.035627	97.10	0.0000
SIMTIME	-0.000769	0.000016	-46.65	0.0000
(ACFT-12)*(COOL-9)	0.0168403	0.005938	2.84	0.0046
(ACFT-12)*(LoP-4)	0.5370784	0.011876	45.22	<.0001
(ACFT-12)*(SIMTIME-10080)	-0.000031	0.000005	-5.73	<.0001
(NITRO-2)*(NITRO-2)	-2.948655	0.039833	-74.03	0.0000

The Tables above are for response-fitting model with aircraft, simulation time and types of AGE. Summary of fit table shows that R-square is approximately 0.97. ANOVA has a small and significant p-value and Lack of fit table has a p-value bigger than 0.05. All these information implies that the model determined fits well to data. Parameter estimates table gives the parameters for every main factor, interaction terms and quadratic term.

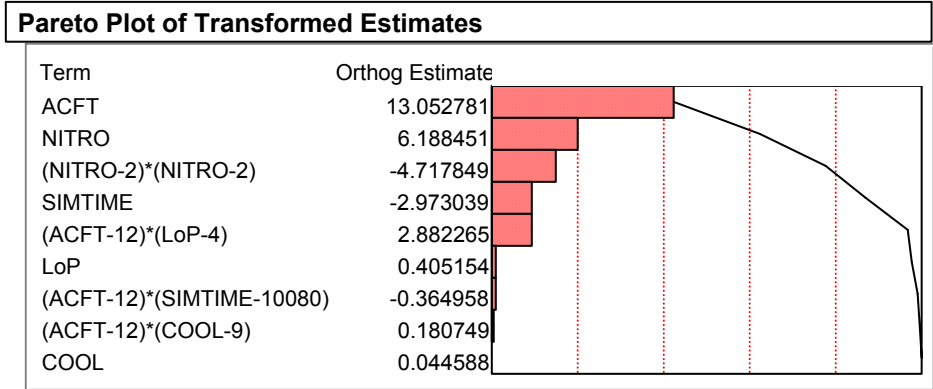

Pareto plot orders the factors and their interactions in terms of their importance or impacts. The biggest impact on FSE comes from aircraft numbers.

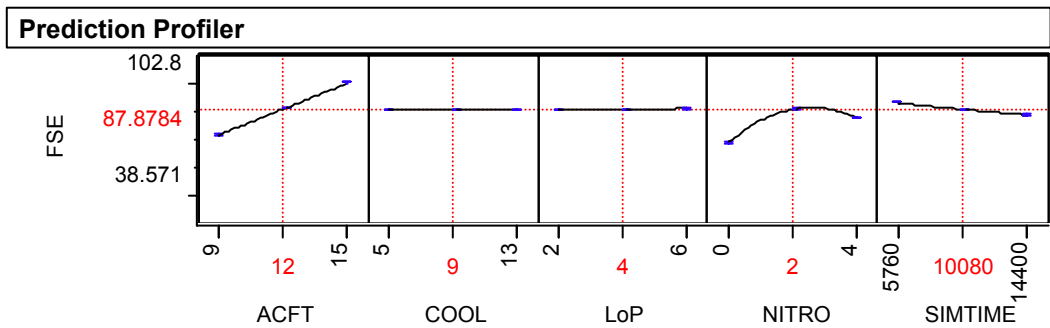

Prediction profiler shows the impacts of the factors. When the angles between the horizontal lines increase, the impact is also increases.



**Cube Plot**

NITRO=0 SIMTIME=5760

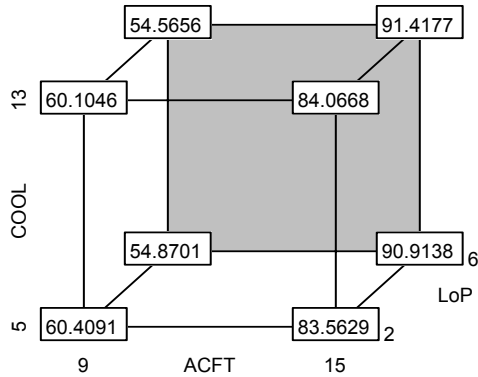

NITRO=4 SIMTIME=5760

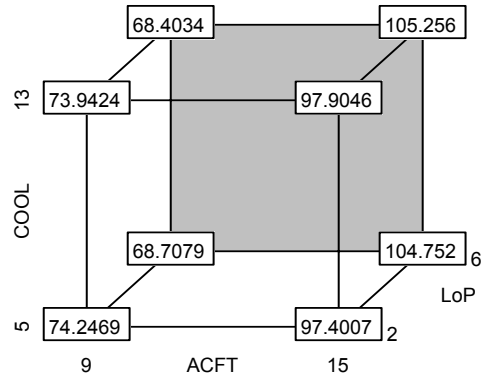

NITRO=0 SIMTIME=14400

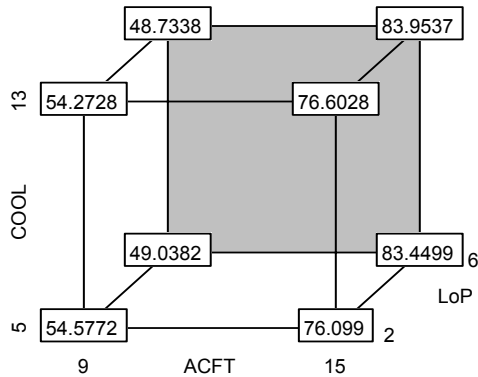

NITRO=4 SIMTIME=14400

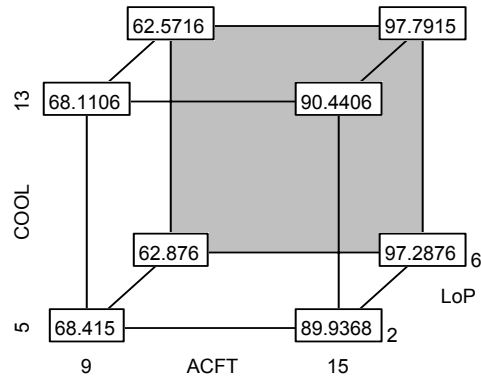

Cube plots show the possible ranges of FSE for possible combinations of factors. The biggest FSE (105.256) rate occurs, when nitrogen=4, simulation time=5760, cooling=13, aircraft numbers=15, low-pressure=6. FSE rate is more than 100. This implies that the combination creates more than enough resource. There are some excessive resources and can be diminished.

## Appendix E. Within AGE Analysis/(only AGE) Response-Fitting Model

Response FSE					
Summary of Fit					
RSquare		0.982047			
RSquare Adj		0.981902			
Root Mean Square Error		3.75015			
Mean of Response		43.89048			
Observations (or Sum Wgts)		2000			
Analysis of Variance					
Source	DF	Sum of Squares	Mean Square	F Ratio	
Model	16	1525492.0	95343.3	6779.423	
Error	1983	27888.2	14.1	Prob > F	
C. Total	1999	1553380.2		0.0000	
Parameter Estimates					
Term		Estimate	Std Error	t Ratio	Prob> t
Intercept		57.067177	0.296475	192.49	0.0000
GEN		1.2273065	0.011719	104.73	0.0000
COOL		1.4721514	0.015626	94.21	0.0000
HYDRA		1.1265944	0.023438	48.07	0.0000
HIP		0.8605442	0.093754	9.18	<.0001
LOP		1.6285431	0.031251	52.11	0.0000
NITRO		0.952381	0.046877	20.32	<.0001
(GEN-8)*(GEN-8)		-0.859089	0.003276	-262.3	0.0000
(GEN-8)*(COOL-6)		0.1840366	0.001953	94.22	0.0000
(GEN-8)*(HYDRA-4)		0.1407977	0.00293	48.06	0.0000
(GEN-8)*(HIP-1)		0.1214923	0.011719	10.37	<.0001
(GEN-8)*(LOP-3)		0.1898562	0.003906	48.60	0.0000
(GEN-8)*(NITRO-2)		0.0857249	0.00586	14.63	<.0001
(COOL-6)*(HIP-1)		0.1451247	0.015626	9.29	<.0001
(GEN-8)*(COOL-6)*(HIP-1)		0.0167765	0.001953	8.59	<.0001
(HYDRA-4)*(HIP-1)		0.2795493	0.023438	11.93	<.0001
(GEN-8)*(HYDRA-4)*(HIP-1)		0.0354486	0.00293	12.10	<.0001

---

Summary of fit Table shows the R-square value as 0.98. ANOVA table indicates that model fits the data well with a p-value less than 0.05. The parameters of the response-fitting model can be found in the Parameter Estimates table.

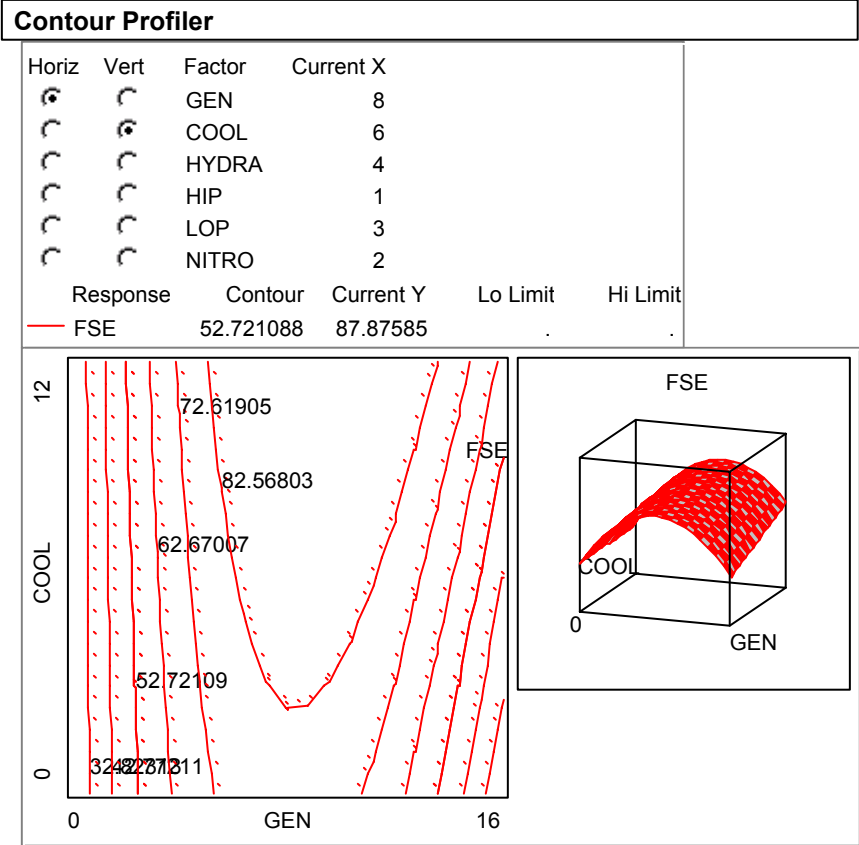

Contour Profiler shows the response surface shape when generator and cooling factors are chosen.

Cube plots below shows the possible FSE rates for different levels of AGE types. From these plots, the biggest FSE rate occurs when all factors are their maximum levels (generator=16, cooling=12, hydraulics=8, high-pressure=2, low-pressure=6, nitrogen=4).

**Cube Plot**

HIP=0 LOP=0 NITRO=0

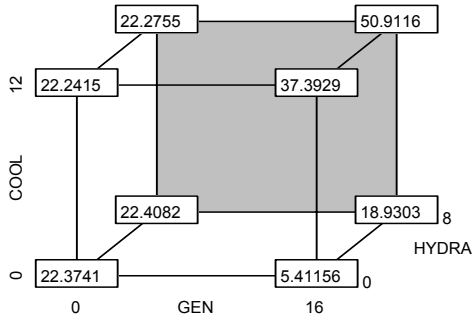

HIP=2 LOP=0 NITRO=0

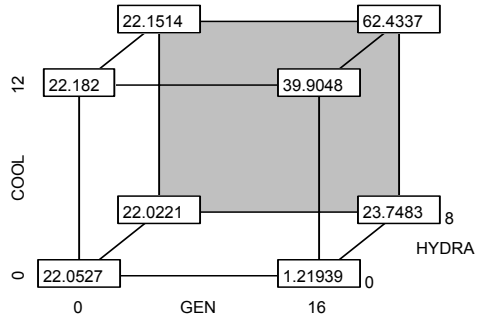

HIP=0 LOP=6 NITRO=0

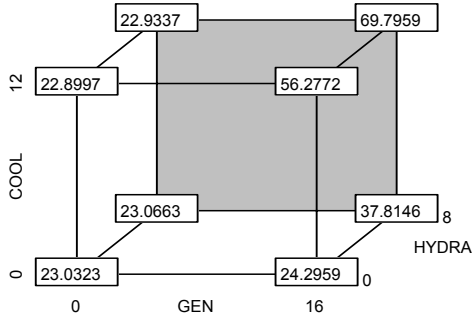

HIP=2 LOP=6 NITRO=0

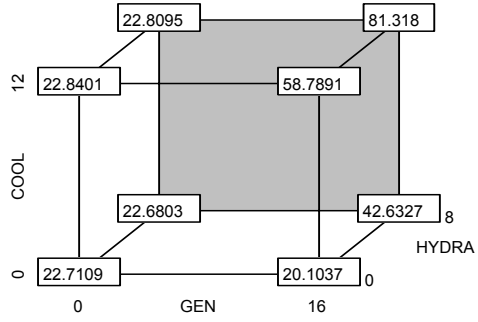

HIP=0 LOP=0 NITRO=4

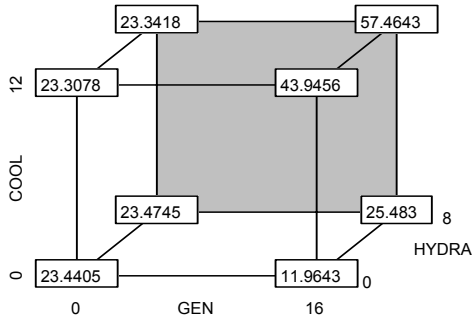

HIP=2 LOP=0 NITRO=4

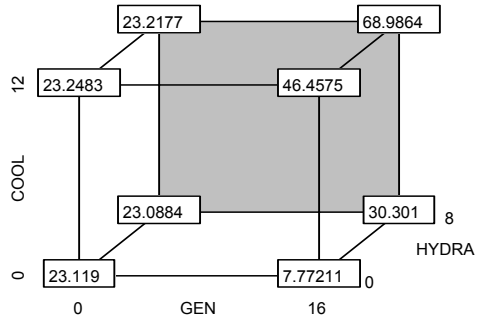

HIP=0 LOP=6 NITRO=4

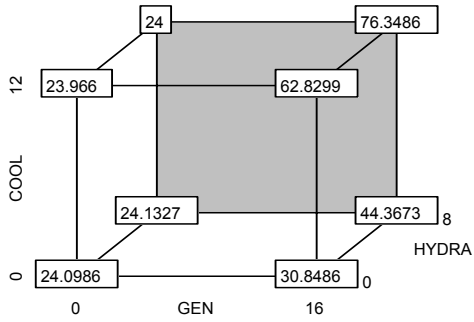

HIP=2 LOP=6 NITRO=4

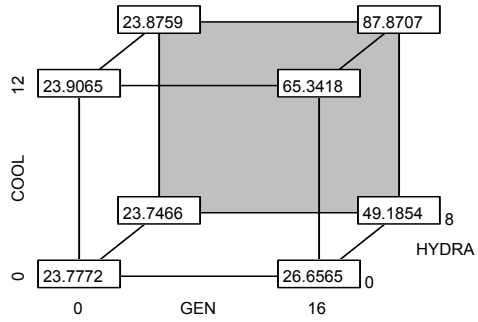

## Appendix F. Between AGE/AGE-MASS Analysis

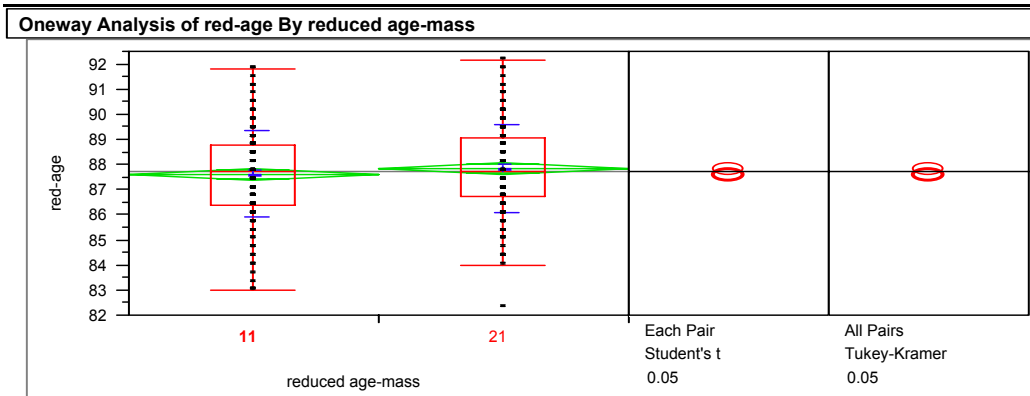
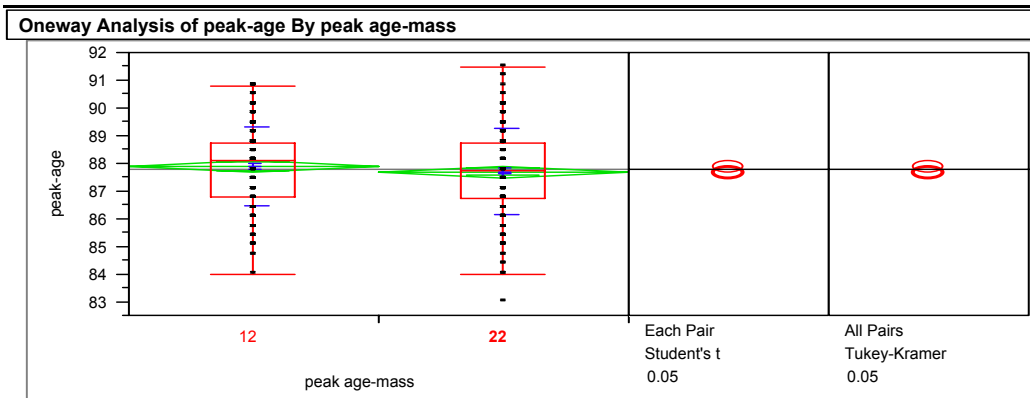
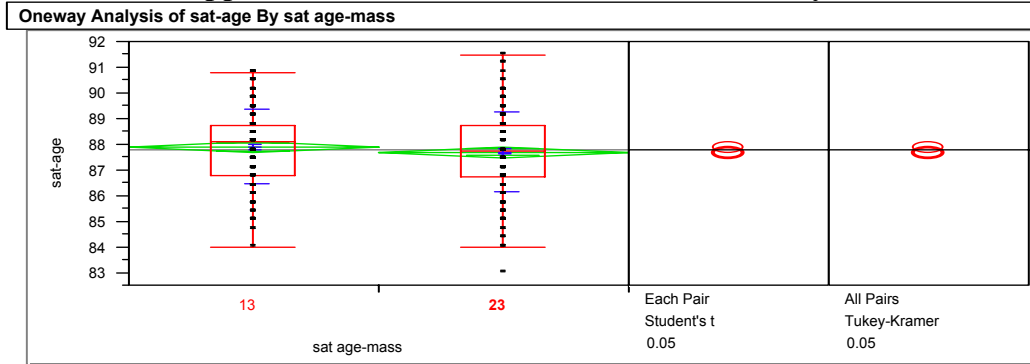

All of the pair-wise one-way analysis above shows that the means between pairs saturated AGE-MASS, maximum AGE-MASS and reduced AGE-MASS, are statistically same. There is no significant difference between means. The substitution with MASS can achieve the same FSE rate.

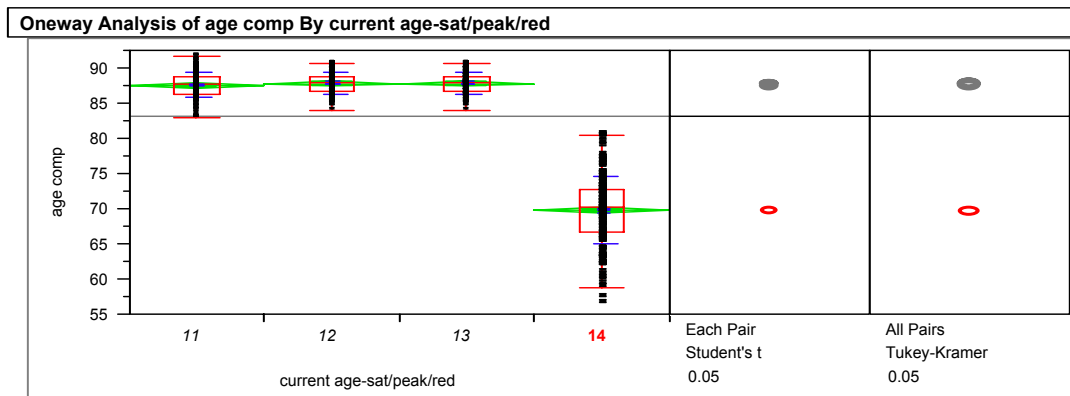

One-way analysis for AGE current deployed and saturated/maximum/reduced indicates the only difference is with current deployed level. Current deployed level decreases FSE rate with the assumed model and has not adequate AGE numbers.

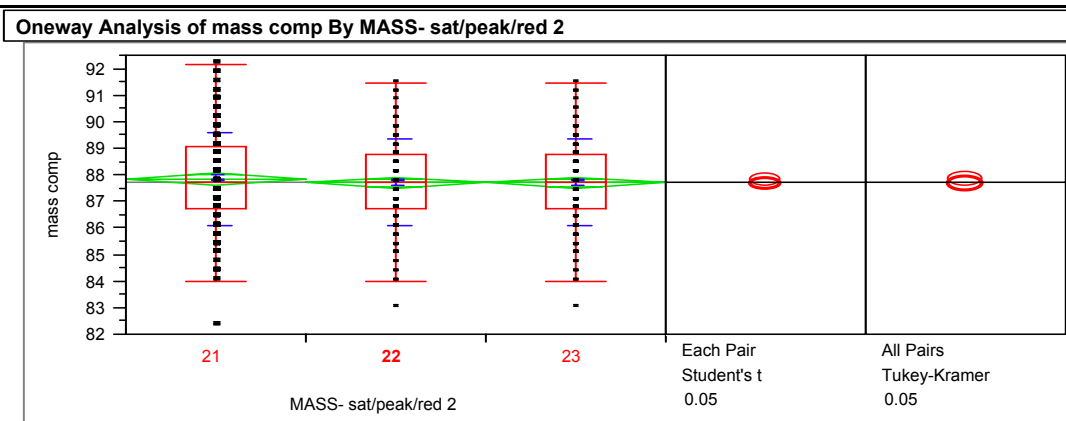
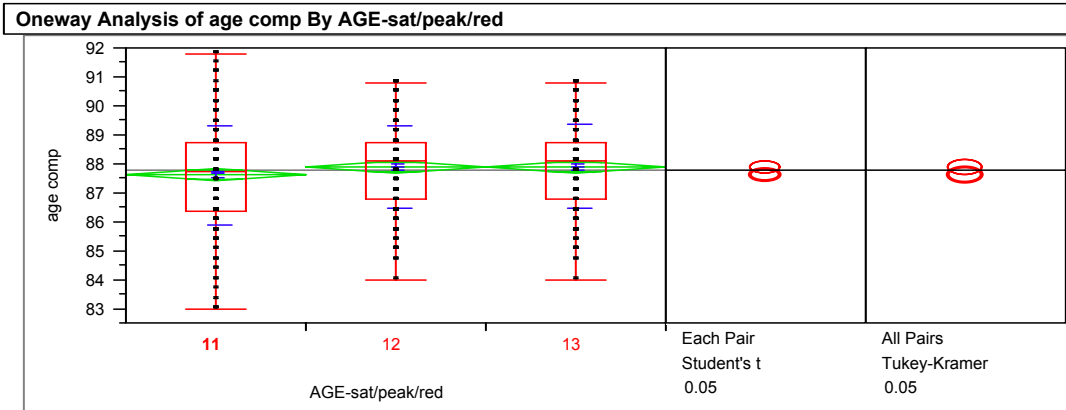

The two plots above indicate that the saturated, maximum and reduced levels of AGE and MASS, respectively, have no significant difference. We can use the reduced levels and still got the approximate FSE rate.

Table F1. Paired-t approach 95% confidence intervals for AGE-MASS

<b>SATURATED MASS VS PEAK MASS</b>		<b>NOT SIGNIFICANT</b>
	UCL=	0.008375759
	LCL=	-0.004974399
<b>PEAK MASS VS REDUCED MASS</b>		<b>NOT SIGNIFICANT</b>
	UCL=	0.243178914
	LCL=	-0.562906805
<b>SATURATED MASS VS REDUCED MASS</b>		<b>NOT SIGNIFICANT</b>
	UCL=	0.244314052
	LCL=	-0.560640583
<b>SATURATED AGE VS PEAK AGE</b>		<b>NOT SIGNIFICANT</b>
	UCL=	0.044220494
	LCL=	-0.047621854
<b>PEAK AGE VS REDUCED AGE</b>		<b>NOT SIGNIFICANT</b>
	UCL=	0.638010138
	LCL=	-0.090391091
<b>SATURATED AGE VS REDUCED AGE</b>		<b>NOT SIGNIFICANT</b>
	UCL=	0.64115834
	LCL=	-0.096940653
<b>SATURATED AGE VS MASS</b>		<b>NOT SIGNIFICANT</b>
	UCL=	0.516488279
	LCL=	-0.162746783
<b>PEAK AGE VS MASS</b>		<b>NOT SIGNIFICANT</b>
	UCL=	0.512059094
	LCL=	-0.151514877
<b>REDUCED AGE VS MASS</b>		<b>NOT SIGNIFICANT</b>
	UCL=	0.154632028
	LCL=	-0.661434749

Paired-t approach confidence levels are shown under Upper Control Limit (UCL) and Lower Control Limit (LCL). Related t critical value is found by 99 degree of freedom and alpha level=0.05. The confidence intervals are built for aircraft types and numbers. If confidence interval includes “0”, then the difference is accepted as “not significant” and reverse. The pairs are determined as “not significant” implies that the differences between means are not statistically significant and can be accepted as similar or reverse.



## Appendix G. The Footprint Dimensions and Subtotals

Table G1. The AGE dimensions and subtotals for scenarios

	<b>FOOTPRINT PER PIECE</b>	<b>CURRENT DEPLOYMENT</b>		<b>SATURATED</b>	
<b>AGE</b>	(SQUARE FEET)	<b>#</b>	<b>SUBTOTAL</b>	<b>#</b>	<b>SUBTOTAL</b>
GENERATOR (AM32A-60A)	53	13	689	75	3975
AIR CYCLE COOLING (AM32C-10)	53	13	689	75	3975
HYDRAULICS TEST STAND (TTU-228E)	70	3	210	75	5250
HIGH PRESSURE AIR COMPRESSOR(MC-1A)	35	0	0	75	2625
LOW PRESSURE AIR COMPRESSOR(MC-2A)	33	5	165	75	2475
NITROGEN CYLINDER (NG-02)	53	0	0	75	3975
	<b>GRAND TOTALS=</b>	<b>34</b>	<b>1753</b>	<b>450</b>	<b>22275</b>
	<b>FOOTPRINT PER PIECE</b>	<b>PEAK</b>		<b>REDUCED</b>	
<b>AGE</b>	(SQUARE FEET)	<b>#</b>	<b>SUBTOTAL</b>	<b>#</b>	<b>SUBTOTAL</b>
GENERATOR (AM32A-60A)	53	15	795	7	371
AIR CYCLE COOLING (AM32C-10)	53	13	689	6	318
HYDRAULICS TEST STAND (TTU-228E)	70	2	140	3	210
HIGH PRESSURE AIR COMPRESSOR(MC-1A)	35	8	280	1	35
LOW PRESSURE AIR COMPRESSOR(MC-2A)	33	6	198	2	66
NITROGEN CYLINDER (NG-02)	53	5	265	1	53
	<b>GRAND TOTALS=</b>	<b>49</b>	<b>2367</b>	<b>20</b>	<b>1053</b>

AGE is individually are summed because of its dimensions.

Table G2. The MASS dimensions and subtotals for scenarios

	FOOTPRINT PER PIECE	CURRENT DEPLOYMENT		SATURATED	
MASS	(SQUARE FEET)	#	SUBTOTAL	#	SUBTOTAL
DIESEL GENERATOR MODULE	25			75	1875
AIR COOLING MODULE	25			75	1875
HYDRAULICS MODULE	25			75	1875
AVIONICS POWER CONVERTER (APC)MODULE	29			75	2175
PNEUMATICS MODULE	25			75	1875
MASS CHASSIS	75			75	5625
	<b>ACTUAL FOOTPRINT=</b>	<b>0</b>	<b>0</b>	<b>450</b>	<b>15300</b>
	<b>GRAND TOTALS=</b>	<b>0</b>	<b>0</b>	<b>450</b>	<b>5625</b>
	FOOTPRINT PER PIECE	PEAK		REDUCED	
MASS	(SQUARE FEET)	#	SUBTOTAL	#	SUBTOTAL
DIESEL GENERATOR MODULE	25	16	400	8	200
AIR COOLING MODULE	25	13	325	6	150
HYDRAULICS MODULE	25	10	250	4	100
AVIONICS POWER CONVERTER (APC)MODULE	29	13	377	6	174
PNEUMATICS MODULE	25	7	175	3	75
MASS CHASSIS	75	16	1200	8	600
	<b>ACTUAL FOOTPRINT=</b>	<b>75</b>	<b>2727</b>	<b>35</b>	<b>1299</b>
	<b>GRAND TOTALS=</b>	<b>75</b>	<b>1200</b>	<b>35</b>	<b>600</b>

MASS modules can be put inside of the chassis in the deployment. Thus, summation is performed related to the MASS chassis quantity. If there are more numbers of modules than chassis, their footprint is added to the grand total.

## Bibliography

- Allen, Jamie D. and M. Brian Bedesem. "Deploying and Sustaining an F-117A Expeditionary Fighter Squadron," *Air Force Journal of Logistics*. Vol. XXII, No.4, pg. 32-36, Winter 1998.
- Anonymous. *Air Force Journal of Logistics*. Vol. XXII, No.1, pg. 10, 1998.
- Booth, Carol. "Considering COTS," *Air Force Journal of Logistics*. Vol. XXII, No.4, pg. 1-5, Winter 1998.
- Boyle, Edward, Matthew Tracy, and Donald Smoot. "Rethinking Support Equipment," *Air Force Journal of Logistics*. pg. 28-31, Fall 1995.
- Burke, Christopher J. and Vincent A. Mabert. "Quickness versus Quantity: Transportation and Inventory Decisions in Military Repairable-Item Inventory Systems," *Air Force Journal of Logistics*. Vol. XXI, No.3-4, pg. 5-9, 1997.
- Chambers, Scott D., William D. Hughes, Shari L. Massengale, Scott A. Miller, and Naoto Mitani. "Unlikely Partners: Two-Level Maintenance and the Air Force Gold Program," *Air Force Journal of Logistics*. pg. 1-4, Spring 1996.
- Condon, Travis, William Cunningham, Kevin Moore, and Kirk Peterson. "A Comparison of Air Force Organic Airlift and Commercial Air Express Distribution Performance," *Air Force Journal of Logistics*. Vol. XXIII, No.1, pg. 8-12, Spring 1999.
- Current Research, "Modular Aircraft Support System," *Air Force Journal of Logistics*. Vol.21, No.3-4, pg. 22, 1997.
- Davidson, Susan A. "Where Is The Battle Line For Supply Contractors?" *Air Force Journal of Logistics*. Vol. XXIII, No.2, pg. 10-13&40, Spring 2000.
- Feinberg, Amatzia, Hyman L. Shulman, Louis W. Miller, and Robert S. Tripp. "EAF Support Challenges," *Air Force Journal of Logistics*. Vol. XXIV, No.1, pg. 2-5&38-39, Spring 2000.
- Festejo, Reginald P. "An Analytical Comparison of the Reduced Footprint of the Modular Aircraft Support System (MASS) vs. Current Aerospace Ground Equipment (AGE)," MS Thesis, AFIT/GOR/ENS/00M-13. School of Engineering and Management, Air Force Institute of Technology, Wright-Patterson AFB OH, March 2000.

- Galway, Lionel and Robert S. Tripp, Timothy L. Ramey, John G. Drew. “Supporting Expeditionary Aerospace Forces-New Agile Combat Support Postures,” Project AIR FORCE, prepared for the UNITED STATES AIR FORCE by RAND, 2000.
- Goedeking, M. A. and R. J. Chrysler, Philip L. Smith. “An Evaluation Of Some Aspects Of Ground Support Equipment Management,” A Research Report, Issued by The School of Logistics AFIT, 1 November 1960.
- Hall, J. Reggie. “Expeditionary Airpower,” *Air Force Journal of Logistics*. Vol. XXV, No.1, pg. 18-29, Spring 2001.
- Hallin, William P. “Agile Combat Support-The New Paradigm,” *Air Force Journal of Logistics*. Vol. XXI, No.3-4, pg. 1-3, 1997.
- “Reengineering Air Force Logistics,” *Air Force Journal of Logistics*. Vol. XXII, No.4, pg. 1-2, Winter 1998.
- Havlicek, Jeffrey D. “Aerospace Ground Equipment’s Impact on Aircraft Availability and Deployment,” MS Thesis. AFIT/GAL/ENS/97S. School of Logistics and Acquisition Management, Air Force Institute of Technology (AU), Wright-Patterson AFB OH, September 97.
- Johnson, Alan W. “Simulation: It’s the Real Thing,” *Air Force Journal of Logistics*. Vol. XXII, No.4, pg. 17-20, Winter 1998.
- Law, Averill M. and W. David Kelton. *Simulation Modeling and Analysis*. Third Edition, Mc Graw Hill, 2000.
- MacKenna, James A. “Requirements-Based Methodology for Determining AGE Inventory Levels,” MS Thesis. School of Engineering and Management, Air Force Institute of Technology, Wright-Patterson AFB OH, March 2001.
- O’Fearn, Frank C. “Reduction of the Aircraft Ground Equipment Footprint of An Air Expeditionary Force,” MS Thesis, AFIT/GOR/ENS/99M-14. School of Engineering, Air Force Institute of Technology, Wright-Patterson AFB, OH, March 1999.
- Patnode, Norman H. “Providing Responsive Logistics Support: Applying LEAN Thinking to Logistics,” *Air Force Journal of Logistics*. Vol. XXIII, No.1, pg. 34-38&41, Spring 1999.
- Rockwell Software. *ARENA STANDARD: VBA Training Course*. Rockwell Automation.
- Sadowski Randall P., W. David Kelton, and Deborah A. Sadowski. *Simulation with ARENA*, WCB/McGraw Hill, 1998.

- Snow, Harry E., Doyle M. Whitlow, Maurice Braginsky and Daniel A. Collins. “Control Of Ground Support Equipment During Conversions,” A Research Report, Issued by The Logistics Education and Research project AFIT, 1 June 1958.
- Snyder, Thomas J. and Stella T. Smith. “The War in the Persian Gulf,” *Air Force Journal of Logistics*. Vol. XXII, No.2, pg. 14-26, Summer 1998.
- Stinson, Nancy A., Malcolm E. Blair, and Alex E. Dubovik. “Needed-Agile Logisticians,” *Air Force Journal of Logistics*. Vol. XXIII, No.3, pg. 34-40, Fall 1999.
- Tracy, Matthew C II, Dwight F. Pavek, and John P. Schroder. “An AGE of Opportunity,” *Air Force Journal of Logistics*. pg. 13-18&27, Spring 1997.
- Tripp, Robert S., Lionel A. Galway, Timothy L. Ramey, Paul S. Killingsworth, John G. Drew, and C. Chris Fair. “Expeditionary Airpower Part 3 – F15 Support Analysis,” *Air Force Journal of Logistics*. Vol. XXIII, No.4, pg. 2-5&36-37, Winter 1999a.
- , Eric Peltz, C. Robert Roll, Lionel Galway, Timothy Ramey, John G. Drew, Mahyar Amouzegar, and Clifford Grammich. “Expeditionary Airpower Part 4-A Vision for Agile Combat Support,” *Air Force Journal of Logistics*. Vol. XXIII, No.4, pg. 6-11&38-40, Winter 1999b.
- , Lionel A. Galway, Timothy L. Ramey, Paul S. Killingsworth, John G. Drew, and C. Chris Fair. “Expeditionary Airpower Part 1-A Global Infrastructure to support EAF,” *Air Force Journal of Logistics*. Vol. XXIII, No.2, pg. 2-7&38-39, Summer 1999c.
- , Lionel A. Galway, Timothy L. Ramey, Paul S. Killingsworth, John G. Drew, and C. Chris Fair. “Expeditionary Airpower Part 2,” *Air Force Journal of Logistics*. Vol. XXIII, No.3, pg. 2-7, Fall 1999d.

## **Vita**

1<sup>st</sup> Lieutenant Ilhan Kaya graduated from Kuleli Military High School in Istanbul, in 1992 and Turkish Air Force Academy in Istanbul with a B.S. degree in Industrial Engineering in 1996. He attended pilot training program in Cigli AFB, Izmir from 1996-1998 and navigator training program in Erkilet AFB, Kayseri from 1998-1999. His follow-on assignment was in Erkilet AFB, Kayseri as a navigator from 1999-2000. He entered the Graduate Operations Research Program, School of Engineering and Management, Air Force Institute of Technology, Wright-Patterson AFB, Ohio. Upon graduation, 1<sup>st</sup> Lieutenant Ilhan Kaya will return to Turkiye.

## REPORT DOCUMENTATION PAGE

*Form Approved*  
OMB No. 074-0188

The public reporting burden for this collection of information is estimated to average 1 hour per response, including the time for reviewing instructions, searching existing data sources, gathering and maintaining the data needed, and completing and reviewing the collection of information. Send comments regarding this burden estimate or any other aspect of the collection of information, including suggestions for reducing this burden to Department of Defense, Washington Headquarters Services, Directorate for Information Operations and Reports (0704-0188), 1215 Jefferson Davis Highway, Suite 1204, Arlington, VA 22202-4302. Respondents should be aware that notwithstanding any other provision of law, no person shall be subject to a penalty for failing to comply with a collection of information if it does not display a currently valid OMB control number.

**PLEASE DO NOT RETURN YOUR FORM TO THE ABOVE ADDRESS.**

<b>1. REPORT DATE (DD-MM-YYYY)</b> 01-09-2001		<b>2. REPORT TYPE</b> Master's Thesis		<b>3. DATES COVERED (From - To)</b> Jun 2001 - Sep 2002	
<b>4. TITLE AND SUBTITLE</b>  MODELING AEROSPACE GROUND EQUIPMENT (AGE) USAGE IN MILITARY ENVIRONMENTS				<b>5a. CONTRACT NUMBER</b>	
				<b>5b. GRANT NUMBER</b>	
				<b>5c. PROGRAM ELEMENT NUMBER</b>	
<b>6. AUTHOR(S)</b>  Kaya, Ilhan, First Lieutenant, TUAF				<b>5d. PROJECT NUMBER</b>	
				<b>5e. TASK NUMBER</b>	
				<b>5f. WORK UNIT NUMBER</b>	
<b>7. PERFORMING ORGANIZATION NAMES(S) AND ADDRESS(S)</b> Air Force Institute of Technology Graduate School of Engineering and Management (AFIT/EN) 2950 P Street, Building 640 WPAFB OH 45433-7765				<b>8. PERFORMING ORGANIZATION REPORT NUMBER</b>  AFIT/GOR/ENS/02-11	
<b>9. SPONSORING/MONITORING AGENCY NAME(S) AND ADDRESS(ES)</b> N/A				<b>10. SPONSOR/MONITOR'S ACRONYM(S)</b>	
				<b>11. SPONSOR/MONITOR'S REPORT NUMBER(S)</b>	
<b>12. DISTRIBUTION/AVAILABILITY STATEMENT</b> APPROVED FOR PUBLIC RELEASE; DISTRIBUTION UNLIMITED.					
<b>13. SUPPLEMENTARY NOTES</b>					
<b>14. ABSTRACT</b> The U.S. Air Force is developing Modular Aircraft Support System (MASS) program to replace the current Aerospace Ground Equipment (AGE). AGE supplies electricity, nitrogen, hydraulics and other support equipment to maintenance activities at the flight line. Current AGE makes up one-third of the deployment footprint. AGE is also mostly aircraft specific, and has reliability problems. The MASS alternative focuses on modularity based on a plug-and-play approach. The technological improvements and possible reduction in the footprint make MASS a good alternative. The AF has to determine now, whether MASS can supply similar functionality and decrease the deployment footprint to theater, while not degrading logistics support for the missions.  The primary focus in this thesis is to determine the important factors that have impacts on Flying Scheduling Effectiveness (FSE), to decrease the footprint related to the important factors and MASS substitution. The maintenance requirements are examined for the flight line support of 3 types of aircrafts (F16CJ, F15C, and F15E) sent to the theater for the Aerospace Expeditionary Force (AEF) and for 7-days period. This thesis re-engineers the AWESIM model created by O'Fearn (1999) extended by Festejo (2000) into ARENA software. The use of Response Surface Methodology (RSM) with simulation is introduced.					
<b>15. SUBJECT TERMS</b> Aerospace Ground Equipment, AGE, Modular Aircraft Support System, MASS, Support Equipment, Footprint Reduction					
<b>16. SECURITY CLASSIFICATION OF:</b>			<b>17. LIMITATION OF ABSTRACT</b>	<b>18. NUMBER OF PAGES</b>	<b>19a. NAME OF RESPONSIBLE PERSON</b>
a. REPORT	b. ABSTRACT	c. THIS PAGE			Raymond R. Hill, Lt Col, USAF (ENS)
U	U	U	UU	92	<b>19b. TELEPHONE NUMBER (Include area code)</b> (937) 255-6565, ext 4323; e-mail: Raymond.Hill@afit.edu