15- ICIST_evizal.pdf

by

Submission date: 16-Mar-2020 04:16PM (UTC+0800)

Submission ID: 1276367411

File name: 15- ICIST_evizal.pdf (818.96K)

Word count: 4229

Character count: 23132

Intelligent System in Container Terminal for Speed-Up Handling Process

⁵
Evizal Abdul Kadir
Department of Information
Technology, Faculty of Engineering,
Universitas Islam Riau, Indonesia
evizal@eng.uir.ac.id

Hitoshi Irie
Center for Environmental Remote
Sensing, Chiba University, Chiba,
Japan
hitoshi.irie@chiba-u.jp

Sri Listia Rosa
Department of Information
Technology, Faculty of Engineering,
Universitas Islam Riau, Indonesia
srilistiarosa@eng.uir.ac.id

ABSTRACT

The growth of economic in some country especially in developing country has impact to movement of goods to deliver or export/import. Most of the movement is using container either land or sea transport. This research presents an intelligent system of **Information and Communication Technology (ICT) in a container terminal for speed up handling process** then more container to serve. A new business process is proposed for a container management system operational flow. The intelligent system used a technology which is Radio Frequency Identification (RFID) incorporated to ICT for the purpose of identifying driver, vehicle, e-seal, and container number. The RFID middleware as the key point manages all the information between Gate Checker (GC) and Container Terminal Management System (CTMS), as well as RFID reader. Middleware receives information requested by GC from reader and is then verified by CTMS database. A new technique for RFID tag filtering and a novel algorithm are introduced for effective processing and communication between CTMS and GC. The proposed system was tested at receiving station of a private container terminal to check the performance. The clearance time reduce significantly compare to previous process, before is 248.1 second per container in average to become 57 second per container.

CCS Concepts

• Information systems → Mobile information processing systems

Keywords

Intelligent; Container; ICT; RFID; Middleware

1. INTRODUCTION

Movement of goods to deliver intercity or domestic freight and even for international export/import keep growing, most of the movement use container either sea or land transport. Some of container terminal very busy to handling the goods and most of terminal with operation 24 hours a day and 365 days a year [1]. Global container trade is projected to grow by average 6% a year and significantly increase since 2010, driven among others by improved prospects for mainline

¹
Permission to make digital or hard copies of all or part of this work for personal or classroom use is granted without fee provided that copies are not made or distributed for profit or commercial advantage and that copies bear this notice and the full citation on the first page. Copyrights for components of this work owned by others than ACM must be honored. Abstracting with credit is permitted. To copy otherwise, to republish, to post on servers or to redistribute to lists, requires prior specific permission and/or a fee. Request permissions from Permissions@acm.org.

ICIST '18, June 30-July 2, 2018, London, United Kingdom

©2018 Association for Computing Machinery.

ACM ISBN 978-1-4503-6461-4/18/06...\$15.00

<https://doi.org/10.1145/3233740.3233743>

East-West trade. Shipping lines handling an estimated more than 50% from total container in global trade around the world by seaborne [2]. This is due to increasing number of goods to deliver and products being transported, especially in festival days. Further, delivery of goods is not only intercompany but to the end of consumer. E-commerce trend become one of lifestyle for the urban people that buying thru online and delivery it to home. Lately, goods and products delivery safety are being given attention by the parties involved such as consignment, freight forwarder, shipping liner and container terminal. Safety and tracking system are important in order to ensure safe delivery at various destinations. Container tracking and monitoring systems have already been implemented at some container ports in order to monitor container movement and give alert in case of problems. Most of the systems use RFID, Global Positioning System (GPS) and Wireless Sensor Network (WSN). ICT implementation in container terminal operational systems and RFID technology were already commissioned in a few container ports in the world; leading to higher efficiency and thereby saving operational costs. Today, some of ports are equipped with RFID technology in order to capture container e-seal; accordingly the world shipping council top 20 ports used RFID technology for container tagging [3]. However, some issues are still posing limitations, which motivated and need further improvements in these systems.

2. LITERATURE REVIEW

RFID technology was implemented in Jebel Ali Port, United Arab Emirates (UAE), in order to increase the reliability and efficiency of the port's operations [4]. Each of containers was tagged by RFID tag which helps in real-time identification and tracking of containers. The method used to define a container was based on the FCAPS network management model. Implementation of ICT in Logistics Service Providers (LSPs) was presented in [5]. Through multiple-case of analysis, the proposed ICT model proved to be suitable for supporting a step-by-step ICT implementation in LSPs.

⁴
RFID technology continues to gain more and more attention in many industrial fields of application, including shipping and container ports. This article proposes a novel RFID tag filtering technique/algorithm to ensure smooth container management system operational flow. Application of IT in the container terminal was discussed, where pervasive computing technologies of RFID were used for investigating Real Time Locating System (RTLS) and also mesh network for container terminal efficiency [6]. The main objective of the paper was to locate container location based on the container's RFID tag. Container Security Initiative (CSI) of the Electronic Container Seal (E-Seal) was proposed in [7]. The basic technical features of RFID systems were described and linked to the practical applications. However, only its application as E-Seal was

discussed without describing its specific implementation on container terminal.

Moreover, the use of RFID technology in container terminal for tracking and allocation of container in yard area and also container traceability were presented in [8-9]. Algorithm and scheduling of container planning were also discussed and simulation of optimization container clearance in temporary place or storage in yard area to achieve faster container movement. The integration and optimization of container scheduling using Particle Swarm Optimization (PSO) in container terminal were presented in [10-11]. The use of RFID technology in container terminal has recently increased due to its numerous advantages. Some of them are (i) capturing of multiple information in many objects, (ii) high throughput of RFID reader and anti-collision protocol and algorithm (iii) emergence of EPC global network and RFID technology for privacy of information privacy and (iv) sensor tag middleware for container monitoring in logistics port system [12-13].

3. TERMINAL OPERATIONAL PROCEDURES

Currently container terminal operations procedure running based on ICT system but some of the procedure is running in manual process such container checking and clearance in receiving. The container gate-in for the reception of containers to be exported still use manual systems controlled by human beings. Every container is received for inspection and manually keyed-in by container staff at receiving office and then the verification is connected to CTMS system [14]. Proposed intelligent system to deploy at receiving gate that consist of six lanes as shows in Figure 1.

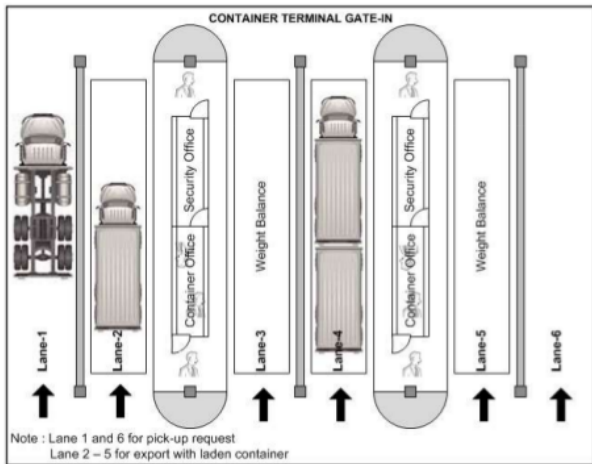

Figure 1. Layout of container terminal gate-in.

Container terminal gate-in is where containers are exported and request pick-up. Mostly gate-in receives laden containers and sometimes receives empty containers. Before container can be exported to vessel, the forward agent must first register the details of container information, such as driver name, vehicle and truck numbers, weight of goods, contents and e-seal number (if any). A systematic procedure must be observed needed before sending containers. All of its details must be updated before the truck arrival at container terminal gate-in.

CTMS Container export/storage procedures:

- 1) Export Booking (EB) – This enables Container Operator (CO) to create export booking detail (mandatory) by inputting JPVC,

POD, size/type, cargo code type, quantity and to assign the booking to Forward Agent (FA), only FA code that are registered with CTMS will be listed.

- 2) Pre-Advise (PA) – This enables the FA/CO to input export or import storage container details. For export user has to select JPVC, export booking number assigned by CO and then input the necessary container information before inputting container number/s. Import storage is for container to be received into container yard and then deliver out by truck and train.
- 3) Pre-Gate In – This enables Haulier (HL) to select container and input container arrival date/ time (ETA) at container terminal Gate-In. All prime moves and trailers must be pre-registered with correct codes and tire weights.
- 4) Terminal Gate-In Inspection – This allows the container to be inspected physically to verify container info against pre-advise/pre-gate before container is allowed to enter terminal. The container staff will reject container without pre-advise, wrong container number & seal number, seal not intact/broken, Dangerous Good (DG) / Hazard (HZ) hold, severe damage or cargo leaking, over weight and prime mover or trailer not registered and matched with truck code in pre-gate.

There are several problems with the current operational procedures, such as slow container processing and clearance time by officer, queue on the road, inefficient operational procedure due to manual processes. For example, the driver needs to go down and pass document manually to officer. Many members are also required to process a container, increasing the risk of human errors. A very important issue is slow processing time, in which the average for the six lanes maximum can process 300,000 TEUs container a year.

4. INTELLIGENT SYSTEM OF ICT FOR HANDLING PROCESS

Process flow after the implementation of the ICT system is changed compared to the previous manual operational system. Figure 2 shows a flow chart for processing container clearance. The container or prime mover enters into the receiving lane and the system checks whether the truck carries a container or only requests pick-up with chassis. The RFID system reads the driver tag, vehicle tag and e-seal, (if e-seal number is not detected, it may be that the container is not tagged by e-seal). In this procedure driver and vehicle tag are compulsory for every truck or prime mover to enter receiving lane. This regulation is enforced at check point of the container terminal Port Safety Management System (PSMS). After all the information captured and a check of the container weight is made to ensure less than 40 tons as maximum weight for every container, then physical checking by the container officer is made the container is cleared.

4.1 Business Process at Container Receiving

In order to specify and analyze in more detail interconnection to current CTMS, a business process flow is write to show the flow of message pass and transfer. Figure 3 shows a business process of container terminal gate-in, where the system is decided into three main parts. Gate checker is a staff of container terminal, CTMS is current system for container planning and RFID reader is proposed system to be implemented into gate-in receiving area. Flow of the messages from the three big parts is interconnected and dependent, if any of the system is down then the system cannot be run. The process flow is indicated in detail below:

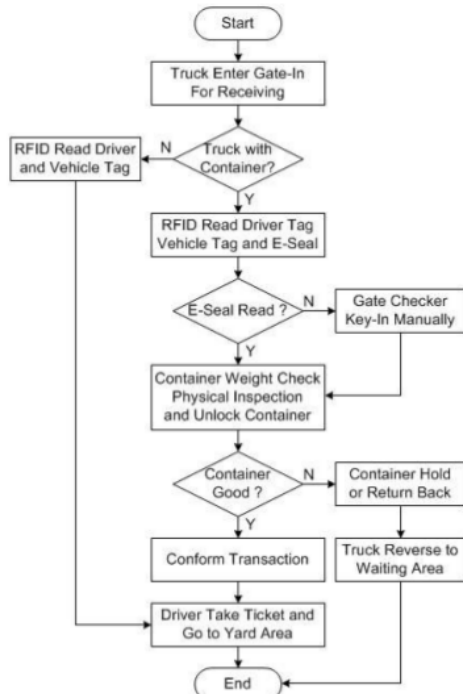

Figure 2. Flow of container receiving used RFID technology.

- 1) Gate Checker (GC) input truck lane number.
- 2) RFID reader reads driver tag, vehicle tag and container e-seal number and retrieve information.
- 3) Hand Held Terminal (HHT) or Table PC display driver name, truck number, e-seal and container number.
 - If no container number, GC can input container number manually by key-in on tablet.
- 4) GC input seal number, condition single container or back to back container.
- 5) CTMS validates, driver name, truck number, container number and e-seal no against pre-advise.
- 6) CTMS calculates container weight.
- 7) HHT or Table PC, display lane number, container number, Dangerous Goods (DG).
 - Weighting figure, gross container weight, container yard location, handling instruction, status (reject/pass)
- 8) CTMS print ticket with conditions:
 - a. Reject if invalid container number, truck number, e-seal number, DG hold, overweight.
 - b. Pass if valid container information, keep transaction logs, truck number, weighting information.
- 9) CTMS sends passed gate lift-off job to Vehicle Mounting Terminal (VMT) on Rubber Tire Gantry (RTG) yard.

4.2 RFID Middleware

The implementation of intelligent system into container terminal operation system as proposed has several parts: the main and most important part is RFID middleware because as the interface between RFID devices, gate checker and container terminal systems (CTMS and PSMS). The middleware algorithms must serve multiple lane information including tag ID, e-seal number. It also functions to help the hardware system to solve some issues in implementation,

which cannot be tackled by adjustment of hardware. Therefore, a combination of hardware and software helps improve the system performance. Algorithms are also required to control and sequence process flow of information to the hardware or gate checker. The messaging structure and flow between RFID middleware and CTMS is implemented so as to achieve effective communication and fast processing because CTMS as central database for container terminal also serve information to other parties. The RFID middleware messaging is also used for communication to the gate checker: the initial request is from gate checker according lane number in gate-in. All messaging is ASCII-based, with START and END delimiters. The middle token represents EMPTY or NULL or NON-APPLICABLE fields. Table 1 shows proposed token code and symbol for communication for both systems.

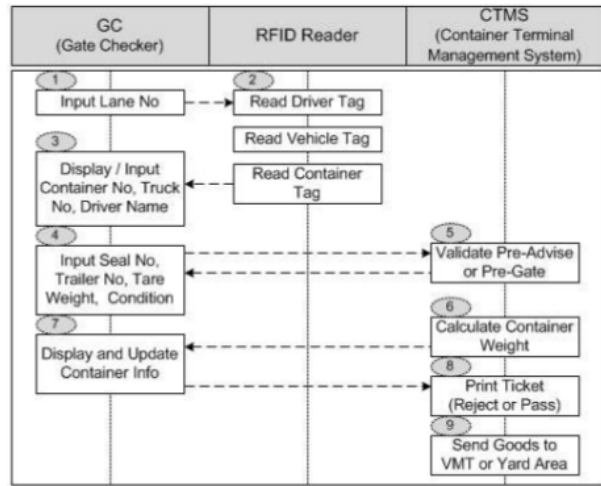

Figure 3. Proposed business process used RFID technology.

Table 1. Proposed RFID middleware system token

Token type	ASCII	Printable Code
Start Token	26	-> (single char)
End Token	27	<- (single char)
Middle Token	29	x (not visible)

The Gate Checker initiates ALL transactions with the RFID middleware software interface. Only four messages are applicable to the RFID interface software, these are messages **R01**, **R04**, **CK** and **CK8**.

- 1) Transaction type: **R01**
 - This is the "Lane Information Request" message, issued by Gate Checker to the RFID middleware software interface.
 - a. **R01 REQUEST** by Gate Checker
 - i. Fields (in the following sequence)
 - R01 (message type)
 - LANE_NO (lane identifier and RFID reader)
 - ii. Format: "->#+1001 R01 LANE01<-"
 - b. **R01 REPLY** by RFID system via Middleware
 - i. Fields (in the following sequence)
 - RST (results)
 - R01 (message type, as requested)
 - LANE_NO
 - DRIVER_NO_RFID (identifiers driver tag ID)

- TRUCK_ID_RFID (identifiers truck/vehicle tag)
- CNTR_NO1_RFID (first container ID)
- CNTR_NO2_RFID (second container ID)
- ii. Format: “->#+1001 RST R01 LANE01 DRIVER123 TRK345 CNTR1111111 CNTR2222222 <-“

Note: A trailer or truck can carry one long 40-foot container or two short 20-foot container.

2) Transaction type: **R04**

This is the “Gate Results” message, issued by the Gate Checker to the RFID middleware interface.

a. **R04 REQUEST** by Gate Checker

- i. Fields (in following sequence)
 - R04 (message type)
 - LANE_NO (lane identifier)
 - DRIVER_NO (identifiers driver tag ID)
 - TRUCK_ID (identifiers truck/vehicle tag)
 - CNTR_NO (container ID)
- ii. Format: “->#+1001 R04 LANE01 DRIVER123 TRK345 CNTR1111111 <-“

b. **R04 REPLY** by RFID system

- i. Fields (in following sequence)
 - RST (results)
 - R04 (message type, as from request)
 - LANE_NO
 - RESULT (**OK** or **ERR**)
- ii. Format: “->#+1001 RST R04 LANE01 OK<-“

3) Transaction type: **CK**

Gate Checker checks for the availability of the RFID interface software.

- a. Gate checker sends “CK” message.
- b. The RFID interface software replies “CK0”

4) Transaction type: **CK8**

RFID interface software checks the availability of the Gate Checkers.

- a. RFID Interface software sends “CK8”
- b. Gate Checker replies “CK7”

The RFID middleware serves the client which is the gate checker. Then the received information from the RFID readers and sensors is processed and verified by the CTMS system. In initial testing, when the middleware received several information items, such as tags ID and e-seal ID with container number, the middleware was unable to verify to which lane the tags belong (multiple lanes testing). Thus, some adjustment and fine tuning of the RFID reader enabled the middleware to identify tags ID and from which lane they came. Another issue is data overload: the reader keeps reading and sending data to middleware, although there is no vehicle or truck in receiving lane (tags belong to others pass thru the area). This issue is solved by limiting the read time of the RFID reader. However, the system cannot recognize whether a truck is on the lane or not, thus this step needs a hardware solution by installing a photoelectric sensor in front and end of lane to start and stop reading. Beside filtering and clearing buffer data the middleware is required to avoid dumping data for next transaction of container clearance, thus an algorithm is proposed to enhance data processing for better and fast processing time.

4.3 Implementation of RFID Technology

Most of the RFID technology currently in use is passive or active [15]. There are advantages and disadvantages of both these types of RFID technology depending on the use and application or implementation. Passive RFID types are inexpensive. However, the

reading performance is limited to a few meters. Active RFID technology can achieve long reading range of tag and store more data inside the tag. However, this is achieved at a higher cost and shorter battery lifetime. Taking into consideration these aspects, as well as results of preliminary testing, active RFID technology is used in this system. Figure 4 shows an algorithm flow for the intelligent system proposed.

The RFID middleware is installed at gate-in receiving lane because the RFID middleware must be close to the RFID readers. This ensures effective data transfer and avoids any data missing or corrupted. Other equipment is the ticket dispenser, which is installed at the end of the lane, enabling driver to pick up the ticket without having to leave the vehicle to collect the inside container office. The placement of the WiFi hotspots is not an issue as long as all gate checkers tablet or handheld devices are able to access Wireless Local Area Network (WLAN) to connect to container terminal system.

5. RESULTS AND DISCUSSION

Improvement and enhancement of e-seal is done by re-designing the passive e-seal tag to obtain a wide and fully open tag to receive signal from reader. Testing this design of the e-seal shows some improvement on the reading performance although in some cases the reader is unable to read the e-seal ID. For back to back containers, the e-seal is placed in the front of the container. Initial tests of the proposed use of ICT and RFID technology in container terminal were conducted at container receiving gate-in. Testing has been done by placing driver and vehicle tags on the truck, e-seal at the back of container. In the initial stage of testing all tags and e-seal used passive type and single lane of container receiving. The results obtained show that the RFID reader captures the RFID tag ID and information when the RFID reader power transmits set to maximum. In the second stage of testing, to check reading performance of RFID reader, lanes 3 and 4 were used. Results show that multiple ID tags ID were captured by the reader, without the possibility to distinguish between lanes. This is because the reader power transmits is too high. Thus in the next testing the reader transmits power is adjusted lower so as to read lane-specific coverage area. Another issue concerns the e-seal reading. When the reader power is reduced the reading of the e-seal deteriorates (this testing e-seal used bullet bolt passive tag) because the environment contains a high level of metal.

Passive RFID tags were previously used as container e-seal in the first trial. However, a lot of technical issues cannot be rectified due to the limitations on passive RFID tags. Using active RFID tags yields better reading. The system contains e-seal with 2.4 GHz, where every protocol and interface uses the same standards. The Shanghai Port RFID system communicates smoothly and provides better services to customers. Also, the port promotes the use of RFID e-seal to other container terminals worldwide. The design of active RFID e-seal, which is similar to mechanical container seals with bolts for locking. This e-seal has sensors, so that there is tampered record in the e-seal once the seal is unplugged without authorization Testing on active RFID e-seals does not generate serious technical issues as the active RFID reader can read longer ranges, though some additional equipment is required as earlier mentioned. This version of e-seal results in improved container clearance. Figure 5 shows a chart of complete cycle timeline container clearance and system communication for a container handling process.

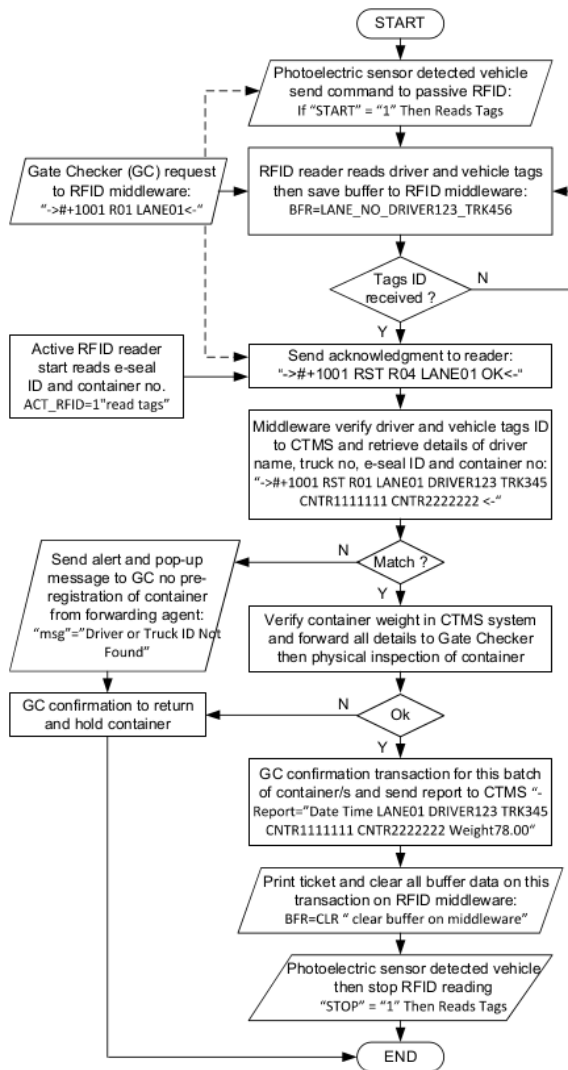

Figure 4. Algorithm flow of RFID middleware.

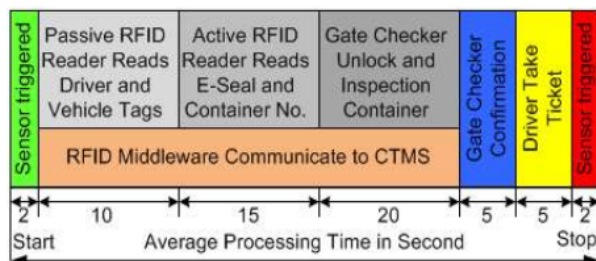

Figure 5. Reading timeline of container in receiving area.

Reviewing the RFID middleware performance, reveals too many buffer data of RFID tags. This is because the RFID reader keeps reading even when no truck is in the receiving lane. Enhancement and filtering of tag data and unnecessary tag information can be

implemented in the software. However, this requires improvement in the reading time. In this scenarios reader only reads when a truck or vehicle is parked into a specific lane. Then the readers start reading the tags. A set of sensors are installed for triggering read starts and stops.

6. CONCLUSION

An RFID system is installed in a container terminal receiving area and implemented intelligent system using ICT technology for faster handling process. Several testing scenarios have been conducted to determine the optimal position of RFID equipment. The best position is fixed at container receiving site and RFID equipment is installed for every lane, one set for each lane. Other support equipment was also installed in optimal positions such as Wi-Fi hotspot, ticket dispenser and photoelectric sensor for triggering the RFID reader start/stop. Upon evaluation of container testing results the various issues arose. To address these there is the need for improvement on e-seal, equipment adjustment and fine tuning, in order to perfect performance of RFID reading. The software also enhances and filters unnecessary data. A new filtering technique and algorithm were introduced in the proposed system to ensure fast communication between gate checker to middleware and between middleware to CTMS. The results have shown great improvement compared to previous manual operating procedure in container processing and clearance. The new system increased container clearance productivity by 76.6% and also reduced the clearance time from 4 minutes per container to 1 minute per container.

7. ACKNOWLEDMENT

Our thank you to Universitas Islam Riau and Ministry of Higher Education of Indonesia (KEMENRISTEKDIKTI) for funding this project, as well as to Center for Environmental Remote Sensing (CeRES), Chiba University, Japan.

8. REFERENCES

- [1] V. F. Valentine, "Global Shipping Market Overview – Implications for Regional Markets," *Conference on Competitiveness of The Maritime Transport – From Global to Regional Scale' the Baltic Ports* Bornholm, Denmark 4-5 September 2014.
- [2] U. Nations, "Review of Maritime Transport," *United Nations Conference on Trade and Development*, 2013.
- [3] M. H. Hakam and W. D. Solvang, "RFID communication in container ports," in *Cognitive Infocommunications (CogInfoCom), 2012 IEEE 3rd International Conference on*, 2012, pp. 351-358.
- [4] M. K. Wafā, U. Suleman, and Z. Arafat, "RFID system implementation in Jebel Ali port," in *Consumer Communications and Networking Conference (CCNC), 2013 IEEE*, 2013, pp. 950-955.
- [5] C. Luisa dos Santos Vieira, A. Sérgio Coelho, and M. M. Mendes Luna, "ICT implementation process model for logistics service providers," *Industrial Management & Data Systems*, vol. 113, pp. 484-505, 2013.
- [6] K. Kap Hwan and B. H. Hong, "Maritime logistics and applications of information technologies," in *Computers and Industrial Engineering (CIE), 2010 40th International Conference on*, 2010, pp. 1-6.
- [7] B. Cai, S. Huang, D. Liu, and G. Dissanayake, "Rescheduling policies for large-scale task allocation of autonomous straddle carriers under uncertainty at automated container terminals," *Robot. Auton. Syst.*, vol. 62, pp. 506-514, 2014.
- [8] C. Zhang, T. Wu, K. H. Kim, and L. Miao, "Conservative allocation models for outbound containers in container terminals," *European Journal of Operational Research*, vol. 238, pp. 155-165, 2014.
- [9] B. Song and Y. Cui, "Productivity changes in Chinese Container Terminals 2006–2011," *Transport Policy*, vol. 35, pp. 377-384, 2014.

- [10] H. J. Carlo, I. F. A. Vis, and K. J. Roodbergen, "Storage yard operations in container terminals: Literature overview, trends, and research directions," *European Journal of Operational Research*, vol. 235, pp. 412-430, 2014.
- [11] Y. Lu and M. Le, "The integrated optimization of container terminal scheduling with uncertain factors," *Computers & Industrial Engineering*, vol. 75, pp. 209-216, 2014.
- [12] B. Fabian, T. Ermakova, and C. Muller, "SHARDIS: A Privacy-Enhanced Discovery Service for RFID-Based Product Information," *Industrial Informatics, IEEE Transactions on*, vol. 8, pp. 707-718, 2012.
- [13] K. Gihong, M. K. Uddin, and H. Bonghee, "Design and Implementation of Sensor Tag Middleware for Monitoring Containers in Logistics Systems," in *Sensor Technologies and Applications, 2009. SENSORCOMM '09. Third International Conference on*, 2009, pp. 393-398.
- [14] A.K. Evizal, "Development of Information and Communication Technology (ICT) in Container Terminal for Speed up Clearance Process", *Journal of Communications* Vol. 12, No. 4, April 2017, pp. 207-213.
- [15] Evizal, T.A. Rahman, S.K.A. Abdul Rahim, "Active RFID Technology for Asset Tracking and Management System", *TELKOMNIKA*, Vol.11, No.1, March 2013, pp. 137-146.

ORIGINALITY REPORT

6%

SIMILARITY INDEX

4%

INTERNET SOURCES

6%

PUBLICATIONS

5%

STUDENT PAPERS

PRIMARY SOURCES

1	Sri Listia Rosa, Evizal Abdul Kadir. "Abnormal internet usage detection in LAN Islamic University of Riau Indonesia", Proceedings of the International Conference on Intelligent Science and Technology - ICIST '18, 2018 Publication	4%
2	Submitted to S P Jain Center of Management Student Paper	1%
3	ieeexplore.ieee.org Internet Source	1%
4	Submitted to University of Moratuwa Student Paper	1%
5	dblp.dagstuhl.de Internet Source	1%

Exclude quotes On

Exclude matches < 1%

Exclude bibliography On