



WestminsterResearch

<http://www.westminster.ac.uk/westminsterresearch>

Enhanced large-scale production of laccases from *Coriopsis polyzona* for use in dye bioremediation

Tingting Cui

School of Life Sciences

This is an electronic version of a PhD thesis awarded by the University of Westminster. © The Author, 2009.

This is an exact reproduction of the paper copy held by the University of Westminster library.

The WestminsterResearch online digital archive at the University of Westminster aims to make the research output of the University available to a wider audience. Copyright and Moral Rights remain with the authors and/or copyright owners.

Users are permitted to download and/or print one copy for non-commercial private study or research. Further distribution and any use of material from within this archive for profit-making enterprises or for commercial gain is strictly forbidden.

Whilst further distribution of specific materials from within this archive is forbidden, you may freely distribute the URL of WestminsterResearch:
(<http://westminsterresearch.wmin.ac.uk/>).

In case of abuse or copyright appearing without permission e-mail
repository@westminster.ac.uk

**ENHANCED LARGE-SCALE PRODUCTION OF
LACCASES FROM CORIOLOPSIS POLYZONA
FOR USE IN DYE BIOREMEDIATION**

Tingting Cui

A thesis submitted to University of Westminster in fulfilment of the requirements for
the degree of Doctor of Philosophy

School of Biociences
University of Westminster
London W1W 6UW
United Kingdom

MAY 2009

ABSTRACT

Pollution from synthetic dyes, released by textile and paper pulping plants, draws major concern. Textile effluents have negative impact both on the environment and human health because they are toxic and some are carcinogenic. Apart from the textile industry, dyes are also widely used in manufacturing industries for leather products, cosmetics, pharmaceuticals, foods and beverages. It is known that white rot fungi can decolourise and detoxify various industrial effluents through the production of extracellular lignin modifying enzymes, a major class of which are laccases (EC 1.10.3.2).

Considering the above, three strains of white rot fungi, *Coriolopsis polyzona* (MUCL 38443), *Pleurotus ostreatus* (ATCC no. MYA-2306) and *Pycnoporus sanguineus* (MUCL 41582) were studied for their ability to produce laccases in liquid media. The effects of mannan oligosaccharides (MO) as elicitor and ferulic acid as inducer were studied using central composite experimental design in liquid cultures of the three strains. The results showed that MO, either added alone or combined with ferulic acid, enhanced laccase activity in the three different cultures and the enhancement was species specific. The highest increase was in liquid cultures of *P. sanguineus* (88-fold) followed by *P. ostreatus* (3-fold) and *C. polyzona* (2-fold), among which *C. polyzona* resulted in the highest laccase activity. The combined addition of 150 mg/l of MO and 1 mM ferulic acid resulted in the optimal laccase activity by *C. polyzona*, whereas additions of 75 mg/l MO to the cultures of *P. sanguineus* and *P. ostreatus* led to the optimal activity.

Extracellular laccase activity was considerably increased when *C. polyzona* was grown in glucose-bactopetone based culture medium induced by ferulic acid. The effect of inoculum conditions on laccase production was studied at reactor scales. Laccase activity achieved with conidia inoculation was higher compared with mycelium inoculation at the early stage of fermentation. However, the laccase levels were similar after 23 days of fermentation (110 U/ml and 100 U/ml for the conidia and mycelia pre-culture respectively). The conidia inoculation is preferred in scale-up when time-cost is considered. The maximal laccase activity with conidia inoculation in a 2 litre stirred tank reactor was 27% higher compared to that in shaken flasks. This showed that *C. polyzona* cultures have the potential to be scaled-up for increased laccase activity by applying conidia inoculum. The fermentation of *C. polyzona* was scaled-up to 20 litre and 150 litre stirred tank reactors applying fed-bath strategy. This resulted in 100 % enhancement of laccase activity.

Addition of oak wood powder in the culture medium increased total laccase activity indicating the potential of lignocellulosic wastes as alternative substrates for enhanced laccase production with reducing cost.

In order to investigate the application of laccases in dye decolourisation, two major laccase isozymes (Lac I & II) from *C. polyzona* were purified to apparent electrophoretic homogeneity using hydrophobic interaction chromatography and ion-exchange chromatography. Both enzymes were found to be monomeric proteins with the same molecular mass of 63 kDa, and isoelectric point of 4.3. Their catalytic activities were studied under various substrates, pHs and temperatures. The highest enzyme affinity and efficiency were obtained with 2,2'-azino-bis-(3-ethylbenzothiazoline-6-sulfonic acid) (ABTS). Compared with other fungal laccases, the laccases from *C. polyzona* have very low K_m values with ABTS as a substrate. The optimum pHs were 2.8, 3.0 and 5.0 on ABTS, 2, 6-dimethoxyphenol (DMP) and syringaldazine, respectively. Both isozymes had acidic optimal pH values. However, they were more stable in neutral pH rather than at acidic pH. Moreover, mass spectrometry (MS) analysis of tryptic digestion products of the two isozymes was performed, which showed further similarity of these two isozymes.

As common physical or chemical methods for dye removal are expensive, have low efficiency and sometimes generate other pollutants, the decolourisation of industrial effluents containing single and mixed dyes was investigated using purified laccase (Lac I) from *C. polyzona* as well as whole cell culture. The method appeared to be an attractive alternative for dye removal. Anthraquinone dyes were found to be more easily decolourised by Lac I compared to azo dyes. The addition of redox mediator ABTS and violuric acid (VA) improved considerably the catalytic efficiencies of azo dyes. Decolourisation, 40-50 %, was achieved for the reactive and the direct dye baths. Response surface technology (RSM) was applied to optimise the decolourisation of the diazo dye reactive black 5 (RB 5) by Lac I. Box-Behnken experimental design with three variables including laccase activity (100, 200, 300 U/l), pH (5, 7, 9) and VA concentration (0, 1.25, 2.5 mM) was studied to identify a significant correlation between the effect of these variables on decolourisation of RB5. The experimental values were in good agreement with the predicted values with the correlation coefficient of 97.4%.

ACKNOWLEDGEMENT

I would like to express my gratitude to my supervisor, Professor Tajalli Keshavarz at University of Westminster for giving his support throughout my PhD study. It has been a great opportunity to learn from his knowledge and apply his expertise in a vast portfolio of projects that I am honoured to be involved in. His dedicated commitment as my personal mentor is greatly appreciated and, without it, I would not have achieved this far within the tight time frame required by the PhD candidature.

I thank my second supervisor, Dr. Stuart Thompson, for his constructive comments and guidance during the course of research and writing.

This work was financially supported by the European Commission, Six Framework Programme (SOPHIED). I would like to take this opportunity to thank all members of SOPHIED project, by whom I had further support to further sharpen my knowledge. This opportunity has been a great eye-opener and a life memory which allows me to exchange ideas with top-notch research groups across Europe. My special thanks also go to Professor Paola Giardina and Mr. Christian-Marie-Bols for their kind arrangement of my stay in their laboratories to extend my research as well as the opportunity to experience the true European research culture.

Thanks also to all technical staff for their prompt actions in assisting me in resolving any practical problems regarding my experiments. Their suggestions are important lessons which can only come with years of experience. I can never feel more confident in handling any sophisticated equipment than ever with the past support from them. I would also like to thank all the people in the School of Biosciences for all the administrative work and interaction during my enjoyable stay at Westminster. They were of a great help that I can put full focus on my research.

I have also not forgotten the enjoyable company of my colleagues at Westminster. Their vast ranges of expertise have widened my perspective in facing problems. On a lighter side, they have kept me with a good balance of play with the never-ending pursuit in research. Without them, I could not have so much fun in this metropolitan city, London. I sincerely thank all of you, my dear friends, Flavia, Orr, Tati, Sheetal, Joseph, for sharing my happiness and sorrow. May our friendship go on forever. My special thanks go to Kwun Ho Ngan from UCL for his continuous support and encouragement throughout this project.

On a personal level, I wish to express my special thanks to Dr. Romeo Radman and Dr. Roberto Parra by offering their experience and a good guiding light during my ups and downs in my study.

Last but not the least, I wish to express my special thanks to my beautiful family for always giving me the support, advice and love whenever I need it. Though we are miles apart, their warmth brings them so close in my heart and this is the best driving force in my intellectual pursuit.

AUTHORS DECLATION

I declare that the present work was carried out in accordance with the Guidelines and Regulations of the University of Westminster. The work is original except where indicated by special reference in the text.

The submission as a whole or part is not substantially the same as any that I previously or am currently making, whether in published or unpublished form, for a degree, diploma or similar qualification at any university or similar institution.

Until the outcome of the current application to the University of Westminster is known, the work will not be submitted for any such qualification at another university or similar institution.

Any views expressed in this work are those of the author and in no way represent those of the University of Westminster.

Signed:

Date: 27-MAY-2009

CONTENTS

ABSTRACT	I
ACKNOWLEDGEMENT	III
AUTHORS DECLATION	IV
CONTENTS	V
LIST OF ABBREVIATIONS.....	XII
LIST OF FIGURES.....	XIII
LIST OF TABLES.....	XVIII
AIM OF THE PROJECT	1
CHAPTER 1: INTRODUCTION	2
1.1 History and Distribution of Laccases	2
1.2 Catalytic Mechanism of Laccases	3
1.2.1 Phenolic Compounds.....	3
1.2.2 Non-Phenolic Compounds	6
1.2.2.1 Laccase Redox Mediators	6
1.3 Characterisation of Fungal Laccases.....	10
1.3.1 Structure of Fungal Laccases	10
1.3.2 Active Site Property of Laccases.....	13
1.3.3 Active Site Exceptions	14
1.3.4 Physico-Chemical Properties of Fungal Laccases.....	15
1.3.4.1 Michaelis Constant and Catalytic Efficiency Constant.....	15
1.3.4.2 Effect of pH on Laccase Activity.....	16
1.3.4.3 Effect of Temperature on Laccase Activity and Stability	17
1.3.5 cDNA and Gene Sequences	18

1.3.6	Mutagenesis of the Active Site.....	18
1.4	Application of Laccases.....	19
1.4.1	Delignification and Pulp Bleaching	20
1.4.2	Dye Degradation.....	21
1.4.2.1	Dye Classification	22
1.4.2.2	Dye Degradation.....	24
1.4.3	Bioremediation	26
1.5	Production of Laccases	26
1.5.1	Effect of Carbon Source and Concentration on Laccase Production ..	27
1.5.2	Effect of Nitrogen Source and Concentration on Laccase Production	28
1.5.3	Effect of Inducers on Laccase Production.....	29
1.5.4	Effect of pH	35
1.5.5	Effect of Temperature	35
1.5.6	Elicitation	38
1.5.7	Recombinant Technology in Laccase Production	39
1.6	Laccase Production at Bioreactor Scale by White Rot Fungi.....	40
1.7	Statistical Approach.....	45
CHAPTER 2: MATERIALS AND METHODS.....		49
2.1	Strains.....	49
2.2	Materials.....	49
2.2.1	Media and Reagents	49
2.2.2	Strains Maintenance	49
2.2.2.1	Maintenance Medium for <i>P. ostreatus</i>	49
2.2.2.2	Maintenance Medium for <i>P. sanguineus</i>	50
2.2.2.3	Maintenance Medium for <i>C. polyzona</i>	50
2.2.3	Production Medium for Laccase Production.....	50

2.2.3.1	Medium Design and Composition.....	50
2.2.3.2	Mannan Oligosaccharides Preparation.....	51
2.2.3.3	Addition of Ferulic Acid and MO.....	51
2.2.4	Medium for laccase production by <i>C. polyzona</i>	52
2.2.4.1	Varying Guucose Cncentration.....	53
2.2.4.2	Addition of Wood Powder.....	53
2.2.5	Fermenter Parameters.....	54
2.2.5.1	Stirred Tank Reactor (2 litre).....	54
2.2.5.2	Stirred Tank Reactor (5 litre).....	54
2.2.5.3	Stirred Tank Bioreactor (20 litre).....	54
2.2.5.4	Stirred Tank Reactor (150 litre).....	55
2.2.6	Dyes and Reagents.....	57
2.2.6.1	Single Dyes.....	57
2.2.6.2	Mixed Dyes.....	58
2.2.6.3	Mediators.....	60
2.2.7	Reagents & Equipment.....	60
2.3	Methods.....	61
2.3.1	Response Surface Technology in Medium Optimization for the Three Strains.....	61
2.3.1.1	Experimental Design and Statistical Analysis in Medium Optimization for Three Strains.....	61
2.3.1.2	Statistical Analysis.....	61
2.3.2	Inoculation and Culture Condition.....	62
2.3.2.1	Inoculation and Culture Conditions of the Three Strains for Laccase Production.....	62
a)	Shaken Flask Studies.....	62
2.3.2.2	Inoculation and Culture Conditions of <i>C. polyzona</i> for Laccase	

Production	63
a) Shaken Flask Studies.....	63
2.3.2.3 Bioreactor Studies (2 litre)	63
2.3.2.4 Bioreactor Studies (5 litre)	65
2.3.2.5 Bioreactor Studies (20 litre)	66
2.3.2.6 Bioreactor Studies (150 litre)	67
2.3.3 Assays.....	68
2.3.3.1 Laccase Assay	68
2.3.3.2 Protein Assay.....	68
2.3.3.3 Glucose Assay	69
2.3.3.4 Biomass Assay	69
2.3.4 Laccase Purification	70
2.3.4.1 Protein Assay.....	70
2.3.5 Laccase Characterisation.....	71
2.3.5.1 Electrophoresis.....	71
2.3.5.2 Isoelectric Point Determination.....	71
2.3.5.3 Size Exclusion Chromatography for Molecular Mass Studies.....	72
2.3.5.4 In-situ Digestion.....	72
2.3.5.5 Mass Spectrometry Analysis	73
2.3.5.6 Enzyme Activity and Stability with respect of pH and Temperature	73
2.3.5.7 Substrate Specificity and Inhibition Studies	73
2.3.6 Dye Decolourisation.....	74
2.3.6.1 Decolourisation of Single Dyes.....	74
2.3.6.2 Decolourisation of mixed dyes.....	74
2.3.6.3 Dye decolourisation rate determination	75

2.3.6.4	Optimization of reactive black 5 (RB5) decolourisation by response surface methodology	76
CHAPTER 3: RESULTS		80
3.1	Introduction to Results	80
3.2	Strain Screening in Shaken Flask Fermentation.....	80
3.2.1	Laccase Production by <i>P. sanguineus</i>	80
3.2.2	Laccase Production by <i>P. ostreatus</i>	83
3.2.3	Laccase Production by <i>C. polyzona</i>	85
3.2.4	Evaluation of the Effect of MO and Ferulic acid on Laccase Production in Shaken Flask cultures of <i>P. sanguineus</i>	87
3.2.5	Evaluation of the Effect of MO and Ferulic Acid on Laccase Production in Shaken Flask Cultures of <i>P. ostreatus</i>	91
3.2.6	Evaluation of the Effect of MO and Ferulic Acid on Production of Laccase in Shaken Flask Culture of <i>C. polyzona</i>	93
3.3	Production of Laccases by <i>C. polyzona</i> in Shaken Flasks and Bioreactors	97
3.3.1	Shaken Flask Fermentation of <i>C. polyzona</i> for Laccase Production Using Conidia Inoculation in Standard Medium.....	97
3.3.2	Effect of Varying Glucose Concentration on Laccase Production in Standard Medium in Shaken Flask Fermentation	98
3.3.3	Effect of Wood Powder on Laccase Production in Shaken Flask Fermentation in Standard Medium (SM)	101
3.3.4	Effect of Inoculum Conditions on Laccase Production in 2 Litre Bioreactor	104
3.3.5	Effect of Wood Powder on Laccase Production in 5 Litre Bioreactor	108
3.3.6	Large Scale Production of Laccases in 20 litre bioreactor	113
3.3.7	Large scale production of laccases in 150 litre bioreactor	116
3.4	Purification and Characterization of Laccases from <i>C. polyzona</i>.....	117
3.4.1	Enzyme Purification.....	117

3.4.2	Properties of Lac I and Lac II.....	119
3.4.3	Laccase Activity with respect to pH and Temperature	123
3.4.4	Catalytic Properties	125
3.4.5	Substrate Specificity and Inhibition Pattern of <i>C. polyzona</i> Laccases 126	
3.4.6	MALDI-MS Analyses	127
3.5	Decolourisation of Textile Dye by Whole Culture of <i>C. polyzona</i> and by Purified Laccase (Lac I).....	129
3.5.1	Single Dye Wastewater Decolourisation by Purified Laccase.....	129
3.5.2	Model Dye Wastewater Decolourisation by Purified Laccase.....	132
3.5.3	Model dye wastewater decolourisation by whole culture	135
3.5.4	Effect of Mediator on Reactive and Direct Acid Dye Decolourisation 137	
3.5.5	Optimization of Reactive Black 5 Decolourisation by Response Surface Methodology	139
	CHAPTER 4: DISCUSSION.....	147
4.1	Strain Screening	147
4.1.1	Medium Optimisation.....	147
4.1.2	Effect of MO and Ferulic Acid.....	148
4.2	Laccase Production by <i>C. polyzona</i> in Shaken Flasks and Bioreactors	150
4.2.1	Effect of Inoculum Type	150
4.2.2	Effect of Glucose Concentration	151
4.2.3	Effect of Shear Stress	152
4.2.4	Effect of Proteases.....	153
4.2.5	Effect of Fed-batch Mode in Laccase Production by <i>C. polyzona</i> in Stirred Tank Reactor	154
4.2.6	Effect of Inducers	155
4.2.6.1	Relationship between Ferulic acid and Biomass.....	155

4.2.6.2	Effect of Lignocellulosic Wastes on Laccase Activity of <i>C. polyzona</i> in Submerged Culture.....	156
4.3	Characterisation of Laccases from <i>C. polyzona</i>	157
4.4	Decolourisation of Single and Mixed Dyes by Purified Laccase and Whole Cell Culture of <i>C. polyzona</i>	160
4.4.1	Laccase and Laccase-mediator System on Decolourisation of Single and Mixed dyes	160
4.4.2	Effect of Mn ²⁺ and H ₂ O ₂ on dye decolourisation by laccase from <i>C. polyzona</i>	164
4.4.3	Application of Response Surface Technology to Optimise Reactive Black 5 Decolourisation by Purified Laccase from <i>C. polyzona</i>	164
CHAPTER 5: CONCLUSION		166
CHAPTER 6: FUTURE WORK.....		169
REFERENCE		171

LIST OF ABBREVIATIONS

ϵ	Extinction coefficient
A_{414}	Absorbance at 414nm
ABTS	2,2'-Azino-bis(3-ethylbenzothiazoline-6-sulfonic acid)
AEX	Anion exchange Chromatography
BSA	Bovine serum albumin
Cu	Copper
DMP	2,6-dimethoxyphenol
%DOT	Dissolved oxygen tension
E^0	Redox potential
g	Centrifuge force
HIC	Hydrophobic interaction chromatography
HPLC	High performance liquid chromatography
KDa	Kilo Dalton
K_m	Michaelis constant
k_{cat}	Catalytic efficiency constant
MALDI-MS	Matrix-assisted laser adsorption ionization-mass spectrometry
Mw	Molecular weight
PAGE	Polyacrylamide gel electrophoresis
PMSF	Phenylmethylsulphonyl fluoride
PDA	Potato dextrose agar
pI	Isoelectric point
RPM	Revolutions per minute
RSM	Response surface technology
SDS	Sodium dodecyl sulphate
T1	Type 1 (copper site)
vvm	Volume of air per volume of culture per minute

LIST OF FIGURES

Figure 1.1: Oxidation of phenolic subunits of lignin by laccases (adapted from Archibald <i>et al.</i> , 1997).....	4
Figure 1.2: Catalytic cycle of a laccase-mediator oxidation system (adapted from Banci <i>et al.</i> , 1999).	7
Figure 1.3: Oxidation of non-phenolic lignin subunits by laccases and a mediator ABTS (adapted from Archibald <i>et al.</i> , 1997).....	8
Figure 1.4: Structure of HBT	9
Figure 1.5: Structure of HAA.....	10
Figure 1.6: Copper centres of the bacterial (CotA) from <i>B. subtilis</i> (adapted from Enguita <i>et al.</i> , 2003).	14
Figure 1.7: The most important chromophores.....	22
Figure 1.8: Chemical structures of lignin-derivatives and monolignol structures.	32
Figure 2.1: Schematic diagram of mannan oligosaccharides (MO).....	51
Figure 2.2: The configuration of 20 litre stirred tank reactor.....	55
Figure 2.3: (A) The pilot scale fermenter system (Wetlands Engineering, Belgium) (B) 50 litre bioreactor (C) 150 litre bioreactor.....	56
Figure 2.4: Structure and chemical class of textile dyes used.....	58
Figure 2.5: Structure of ABTS and VA.....	60
Figure 3.1: Time course of laccase production by <i>P. sanguineus</i> in the selected media in 500 ml shaken flask fermentation: run no.3 (Δ); run no.5 (■); run no.8 (○); run no.9 (●). Laccase assay was done in triplicate for all samples and results are expressed as the mean values within a standard deviation of less than 5%.	81
Figure 3.2: Time course of laccase production by <i>P. ostreatus</i> in the selected media in 500 ml shaken flask fermentation: run no.10 (■); run no.11 (Δ). Laccase assay was done in triplicate. Results are expressed as the mean values within a deviation of less than 5%.	83
Figure 3.3: Time course of laccase production by <i>C. polyzona</i> in the selected media in 500 ml shaken flask fermentation: run no.2 (◇); run no.4 (▲); run no.6 (●); run no.11 (□).Laccase assay were done in triplicate. Results are expressed as the mean values within a deviation of less than 5%.	85

Figure 3.4: Time course of laccase activity produced by *P. sanguineus* under the different experimental conditions tested in the experiment. R1 (□): 0.5 mM ferulic acid and 75 mg/l MO; R2 (◇): 1.0 mM ferulic acid and 75 mg/l MO; R3 (Δ): 0.5 mM ferulic acid and 150 mg/l MO; R4 (●): 1.0 mM ferulic acid and 150 mg/l MO; R5 (⊙): 150 mg/l MO; R6 (■) 0.5 mM ferulic acid and 75 mg/l MO; R7 (▲) 1.0 mM ferulic acid; R8 (○) Control. Figure represent means of triplicate experiments and bars the standard error.88

Figure 3.5: Response surface of laccases activity produced by *P. sanguineus* under the experimental conditions.....90

Figure 3.6: Time course of laccase activity produced by *P. ostreatus* under the different experimental conditions tested in the experiment. R1 (□): 0.5 mM ferulic acid and 75 mg/l MO; R2 (◇): 1.0 mM ferulic acid and 75 mg/l MO; R3 (Δ): 0.5 mM ferulic acid and 150 mg/l MO; R4 (●): 1.0 mM ferulic acid and 150 mg/l MO; R5 (⊙): 150 mg/l MO; R6 (■) 0.5 mM ferulic acid and 75 mg/l MO; R7 (▲) 1.0 mM ferulic acid; R8 (○) control. Figure represent means of triplicate experiments and bars the standard error.....91

Figure 3.7: Response surface of laccases activity produced by *P. ostreatus* under the experimental conditions.93

Figure 3.8: Time course of laccase activity produced by *C. polyzona* under the different experimental conditions tested in the experiment. R1 (□): 0.5 mM ferulic acid and 75 mg/l MO; R2 (◇): 1.0 mM ferulic acid and 75 mg/l MO; R3 (Δ): 0.5 mM ferulic acid and 150 mg/l MO; R4 (●): 1.0 mM ferulic acid and 150 mg/l MO; R5 (⊙): 150 mg/l MO; R6 (■) 0.5 mM ferulic acid and 75 mg/l MO; R7 (▲) 1.0 mM ferulic acid; R8 (○) control Figure represent means of triplicate experiments and bars the standard error.....94

Figure 3.9: Response surface of laccases activity produced by *C. polyzona* under the experimental conditions96

Figure 3.10: Laccase activity, glucose concentration and specific activity measured in the cultures of *C. polyzona* with conidia inoculation using standard medium. Laccase assay was done in triplicate for all samples and results are expressed as the mean values within a standard deviation of less than 5%.....98

Figure 3.11: Effect of glucose concentration on laccase production by *C. polyzona* grown in 500 ml shaken flasks (Values shown represent average of triplicate samples, error bars represent standard deviation). The arrow indicates the addition of 1 mM ferulic acid on the 3rd day of fermentation.99

Figure 3.12: Glucose consumptions measured in shaken flask cultures of *C. polyzona* with different initial glucose concentration (Values shown represent average of triplicate samples, error bars represent standard deviation)..... 100

Figure 3.13: Biomass concentrations measured in shaken flask cultures of <i>C. polyzona</i> with different initial glucose concentration (Values represent average of triplicate samples, error bars represent standard deviation).....	101
Figure 3.14: Time course of laccase activity in the control (no wood powder) and wood powder supplemented cultures in shaken flask fermentation. (■) wood powder + SM; (▲) control (SM). The fed-batch additions were: (a) 1mM ferulic acid; (b) 10 % (w/v) SM + 0.1 mM ferulic acid; (c) 1mM ferulic acid. The fermentation was carried out in triplicate and the error bars represent the standard error of the mean of triplicate samples.....	102
Figure 3.15: pH profiles in the control and wood powder supplemented cultures in shaken flask fermentation. (■) wood powder + SM; (▲) control (SM). The fermentation was carried out in triplicate and the error bars represent the standard error of the mean of triplicate samples.....	103
Figure 3.16: Laccase activity, glucose concentration and pH measured in 2 litre bioreactor using conidia inoculation. The fed-batch additions were: (a) 1mM ferulic acid; (b) 20 % SM; (c) 1mM ferulic acid; (d) 20% SM; (e) 1mM ferulic acid. All the assays were done in triplicate for all samples analysis and results are expressed as the mean values within a standard deviation of less than 5%.	105
Figure 3.17: Laccase activity, glucose concentration and pH measured in 2 litre bioreactor using mycelia inoculation. The fed-batch additions were: (a) 1mM ferulic acid; (b) 20 % SM + 0.1 mM ferulic acid; (c) 1mM ferulic acid; (d) 20% SM; (e) 1mM ferulic acid. All the assays were done in triplicate for all samples analysis and results are expressed as the mean values within a standard deviation of less than 5%.	106
Figure 3.18: Time course of laccase activity of <i>C. polyzona</i> fed-batch culture in 2 litre bioreactors with two different inoculum preparations.	107
Figure 3.19: Final biomass obtained by dry cell weight produced in the 2 litre bioreactors.	108
Figure 3.20: Time course of fermentations in 5 litre bioreactors. Symbols: (■) wood powder supplemented culture; (▲) control-standard medium (SM). The Fed-batch additions on the fermenters were: (a) ferulic acid 1mM; (b) 10% SM + 0.1 mM ferulic acid; (c) ferulic acid 1mM; (d) 20% SM + 40 mg/l CuSO ₄ ; (e) 20% SM-without bactopectone. All the assays were done in triplicate for all samples analysis and results are expressed as the mean values within a standard deviation of less than 5%.....	110
Figure 3.21: Time course of pH in the fermenters. Symbols: (■) wood powder supplemented culture; (◆) control (SM). All the assays were done in triplicate for all samples, the results are expressed as the mean values within a standard deviation of less than 5%.....	111

Figure 3.22: Time course of biomass in the fermenters. Symbols: (■) wood powder supplemented culture; (▲) control (SM).	112
Figure 3.23: Blockage of air inlet system by anchored biomass in the air pipe.....	113
Figure 3.24: Fed-batch profile of <i>C. polyzona</i> and production of laccase in 20 litre stirred tank reactor. Arrows indicate the time of fresh medium and inducer addition. Symbols: (▲) laccase activity; (◇) pH; (●) glucose concentration; (○) total extracellular protein. (a) 1mM ferulic acid; (b) 20 % SM (w/v) ; (c) 0.2 mM ferulic acid; (d) 20 % SM (w/v); (e) 0.2 mM ferulic acid; (f) 20 % SM (w/v); (g) 0.2 mM ferulic acid; (h) 20 % SM (w/v); (i) 0.2 mM ferulic acid. All the assays were done in triplicate for all samples analysis and results are expressed as the mean values within a standard deviation of less than 5%.	114
Figure 3.25: Fed-batch profile of <i>C. polyzona</i> and production of laccase in 20 litre stirred tank reactor. Arrows indicate the time of fresh medium and inducer addition. Symbols: (●) laccase activity; (◇) pH; (▼) glucose concentration; (Δ) total extracellular protein concentration. (a) 1mM ferulic acid; (b) 20 % SM; (c) 0.2 mM ferulic acid. All the assays were done in triplicate for all samples analysis and results are expressed as the mean values within a standard deviation of less than 5%.	116
Figure 3.26: Purification of laccases from <i>C. polyzona</i> by Mono-Q chromatography after HIC. Absorbance at 280 nm (red line), the NaCl gradient (green line) and the laccase activity (●) are as indicated.	119
Figure 3.27: Determination of molecular mass of purified laccase isoenzymes from <i>C. polyzona</i> . a, crude sample; b, HIC (elution); c, peak 1(Mono Q elution); peak 2 (Mono Q elution).....	120
Figure 3.28: Calibration curve for determination of molecular mass for laccases from <i>C. polyzona</i> relative to the elution volume of protein standards on a pre-packed size exclusion chromatography column.	121
Figure 3.29: Determination of pI of purified laccase isoenzymes from <i>C. polyzona</i> . a, peak 1 (Mono Q elution); b, peak 2 (Mono Q elution).....	122
Figure 3.30: Native PAGE staining with 2.5 mM ABTS (a) HIC (wash); (b) peak 1 (Mono Q elution); (c) peak 2 (Mono Q elution).	123
Figure 3.31: Dependence of isoenzymes from <i>C. polyzona</i> on pH and temperature. Laccase activity at different pHs using substrates: (a) ABTS; (b) DMP; (c) SYN. (d) Laccase activity at different temperatures. All the assays were done in triplicate for all samples and results are expressed as the mean values within a standard deviation of less than 5%.	124
Figure 3.32: MALDI-MS spectra analysis of tryptic digestion products of Lac I and Lac II.	128

Figure 3.33: Effect of Mn^{2+} and H_2O_2 on purified laccase-mediated acid dye bath wastewater (wool) decolourisation (Values shown represent average of duplicate samples, error bars represent standard deviation).	132
Figure 3.34: Effect of Mn^{2+} and H_2O_2 on purified laccase-mediated acid dye bath (leather) wastewater decolourisation (Values shown represent average of duplicate samples, error bars represent standard deviation).	133
Figure 3.35: Effect of Mn^{2+} and H_2O_2 on purified laccase-mediated direct dye bath (cotton) wastewater decolourisation (Values shown represent average of duplicate samples, error bars represent standard deviation).	134
Figure 3.36: Effect of Mn^{2+} and H_2O_2 on culture liquid (CL)-mediated acid dye bath wastewater (wool) decolourisation (Values shown represent average of duplicate samples, error bars represent standard deviation).	135
Figure 3.37: Effect of Mn^{2+} and H_2O_2 on culture liquid (CL)-mediated acid dye bath (leather) wastewater decolourisation (Values shown represent average of duplicate samples, error bars represent standard deviation).	136
Figure 3.38: Effect of violuric acid (VA) on purified laccase (Lac I) and culture liquid (CL)-mediated reactive dye bath wastewater (cotton) decolourisation (Values shown represent average of triplicate samples, error bars represent standard deviation).....	137
Figure 3.39: Effect of violuric acid (VA) on purified laccase (Lac I) and culture liquid (CL)-mediated direct dye bath wastewater (cotton) decolourisation (Values shown represent average of triplicate samples, error bars represent standard deviation).....	138
Figure 3.40: Surface response for RB5 decolourisation as a function of laccase activity and pH.	144
Figure 3.41: Surface response for RB5 decolourisation as a function of laccase activity and [VA].....	145
Figure 3.42: Surface response for RB5 decolourisation as a function of pH and [VA].	146

LIST OF TABLES

Table 1.1: Physico-chemical properties of laccases from different fungi based on four substrates.	12
Table 1.2: Colour Index application classes (Christie, 2001)	23
Table 1.3: Substrates reported on the laccase production by different species of white rot fungi	35
Table 1.4: Different bioreactor scales for production of laccases by filamentous fungi	42
Table 2.1: Experimental design combinations for production media	51
Table 2.2: Concentrations and levels for different combination of factors to be investigated.....	52
Table 2.3: Composition and concentration for laccase production medium of <i>C. polyzona</i>	53
Table 2.4: Composition of model wastewater containing single dye.....	57
Table 2.5: Composition of the four investigated model wastewater preparations containing mixed dyes.....	59
Table 2.6: Factors and levels used for the central composite design.	61
Table 2.7: Feeding compositions and addition time during the fed-batch fermentation of <i>C. polyzona</i> in 2 litre bioreactor.....	65
Table 2.8: Feeding compositions and addition time during the fed-batch fermentation of <i>C. polyzona</i> in 5 litre bioreactor.....	66
Table 2.9: Feeding compositions and addition time during the fed-batch fermentation of <i>C. polyzona</i> in 20 litre bioreactor.....	67
Table 2.10: Feeding compositions and addition time during the fed-batch fermentation of <i>C. polyzona</i> in 150 litre bioreactor.	68
Table 2.11: Protein assay solution.....	69
Table 2.12: The levels of variables chosen for RB5 decolourisation.....	77
Table 2.13: The Box-Behnken design for the three independent variables.	78
Table 3.1: Maximum laccase activity achieved in eleven tested media composition by <i>P. sanguineus</i>	82

Table 3.2: Maximum laccase activity achieved in eleven tested media composition by <i>P. ostreatus</i>	84
Table 3.3: Maximum laccase activity achieved in eleven tested media composition by <i>C. polyzona</i>	86
Table 3.4: Optimal media compositions for laccase production by the three white rot fungi strains. R stands for medium and the subsequent number for the experimental run based on the experimental design.	87
Table 3.5: Analysis of variance of the central composite experimental design for the laccases produced by <i>P. sanguineus</i>	89
Table 3.6: Analysis of variance of the central composite experimental design for the laccases produced by <i>P. ostreatus</i>	92
Table 3.7: Analysis of variance of the central composite experimental design for laccase produced by <i>C. polyzona</i>	95
Table 3.8: Purification of laccase isoenzymes from <i>C. polyzona</i>	118
Table 3.9: Kinetic properties of laccases of selected substrates.....	125
Table 3.10: Substrate specificity of <i>C. polyzona</i> laccase.....	126
Table 3.11: Effect of various inhibitors on oxidation of ABTS by purified <i>C. polyzona</i> laccases.....	127
Table 3.12: Comparison of decolourisation rate of selected single dyes using purified Lac I.....	129
Table 3.13: Experimental design and response (observed and predicted) of the Box-Behnken.....	140
Table 3.14: ANOVA results for RB5 decolourisation, quadratic response surface model fitting.....	141
Table 3.15: Regression coefficient of the model.....	142

AIM OF THE PROJECT

Laccases are important and promising enzymes for various industrial applications. However, their constitutive production from white rot fungi is very low. This greatly hinders their industrial exploitation.

This project aims to investigate the production and enhancement of laccase activity, by selected white rot fungi, through fermentation at different scales for their applications in dye decolourisation.

To address the above aim, the following objectives were considered:

1. To perform strain screening and select a good candidate for laccase production.
2. To study the inoculum and media optimisation for improvement in laccases production from the selected fungi.
3. To investigate enhancement of laccase activity by the selected fungi at low cost via different strategies, such as inducer addition, fed-batch, and lignocellulosic wastes.
4. To investigate enhanced production of laccases at large-scale using the selected fungus.
5. To perform the purification and characterisation of laccases from the selected fungus.
6. To investigate decolourisation of industrial dye effluents including single dyes (eg. azo, diazo, anthraquinone) and mixed dyes (acid dye bath, reactive dye bath, direct dye bath) using laccases or whole cell culture.

CHAPTER 1: INTRODUCTION

1.1 History and Distribution of Laccases

Laccases are widely distributed in nature and occur in various plants, fungi and bacteria. (Sterjiades *et al.*, 1992, Givaudan *et al.*, 1993, Liu *et al.*, 1994, Thurston, 1994, Martins *et al.*, 2002, Hoopes and Dean, 2004).

The first laccase was found in 1883 from *Rhus vernicifera*, the Japanese lacquer tree by Yoshida, from which the studies of laccases started. Even though the detection and purification of laccases from plants were restricted due to the large amount of oxidative enzymes contained in the crude plant extracts, laccase from *R. vernicifera* was studied extensively especially regarding its spectroscopic properties (Malmström *et al.*, 1970, Woolery *et al.*, 1984). *R. vernicifera* laccase was also used to investigate the general reaction mechanism of laccases (Johnson *et al.*, 2003).

In 1896, fungal laccase was discovered by both Bertrand and Laborde (Thurston, 1994). In fungi, laccases are extracellular multicopper-containing oxidoreductases prominent in white-rot basidiomycetes which are considered to contribute to lignin degradation. Some of the most important and well-studied white-rot fungi are *Pleurotus ostreatus* (Sannia *et al.*, 1986), *Phlebia radiata* (Nikupaavola *et al.*, 1988), *Coriolus (Trametes, Polyporus) versicolor* (Rogalski *et al.*, 1991), and *Pycnoporus cinnabarinus* (Eggert *et al.*, 1996b). Laccases are also produced by ascomycetes, deuteromycetes as well as yeasts (Junghanns *et al.*, 2005). Laccase from *Monocillium indicum* was the first one to be characterised from an ascomycete showing peroxidative activity (Thakker *et al.*, 1992). Other examples include strains of non-ligninolytic ascomycetes from the genera *Aspergillus* and *Neurospora* (Bollag and

Leonowicz, 1984), the deuteromycete wine fungus *Botrytis cinerea* (Gigi et al., 1981). Laccases are thought to be nearly ubiquitous among fungi; actually the presence of laccases has been documented in virtually every fungus examined for it (Mayer and Staples, 2002). Laccases are produced in multiple isoforms depending on the fungal species and environmental conditions. Although the structure of the active site seems to be conserved in all the fungal laccases, there is great diversity in the rest of the protein structure and in the sugar moiety of the enzyme. Several protein sequences in bacterial genomes have been found with significant similarity to fungal laccases (Alexandre and Zhulin, 2000). Apart from *Bacillus subtilis* spores (Martins et al., 2002), laccase activity was found in the soil bacterium *Azospirillum lipoferum* (Givaudan et al., 1993) and the marine bacteria *Marinomonas mediterranea* (Fernandez et al., 1999, Sanchez-Amat et al., 2001).

1.2 Catalytic Mechanism of Laccases

Laccases (benzenediol: oxygen oxidoreductase, EC1.10.3.2) belong to a group of multicopper oxidases, which typically contain two or four copper atoms in the catalytic centre, and catalyze oxidation reactions where electrons are removed from reducing substrate molecules and transferred to oxygen to form water. Other enzymes in this group are the plant ascorbate oxidases and the mammalian plasma protein ceruloplasmin (Thurston, 1994, Xu, 1996, Ducros et al., 1998).

1.2.1 Phenolic Compounds

Laccases catalyze the reduction of oxygen to water accompanied by the oxidation of a substrate, typically a p-dihydroxy phenol or another phenolic compound (Baldrian, 2006). In contrast to most enzymes, which are generally substrate specific, laccases act on a surprisingly broad range of substrates including diphenols, polyphenols, different substituted phenols, diamines, aromatic amines and other easily oxidized aromatic compounds, benzenethiols (Xu, 1996). There are some well-known

substrates for laccases, including 3, 5-dimethoxy-4-hydroxybenzaldehyde azine (syringaldazine, SYR), 1-naphtol, p-cresol (1-hydroxy-4-methylbenzene), 2, 6-dimethoxyphenol (DMP) and 2-methoxyphenol (guaiacol, GUA) or compounds secreted by lignolytic fungi (Abadulla, 2000). When oxidized by a laccase, the reducing substrate loses a single electron and usually forms a free radical. After the initial step, the unstable radical may carry on a second laccase-catalysed oxidation (converting phenol to quinone) or non-enzymatic reactions, such as hydration, disproportionation and polymerization (Thurston, 1994).

In lignin (as shown in Figure 1.1), phenolic subunits are cleaved by laccase, giving oxygen-centred radicals that can subsequently polymerize or depolymerise.

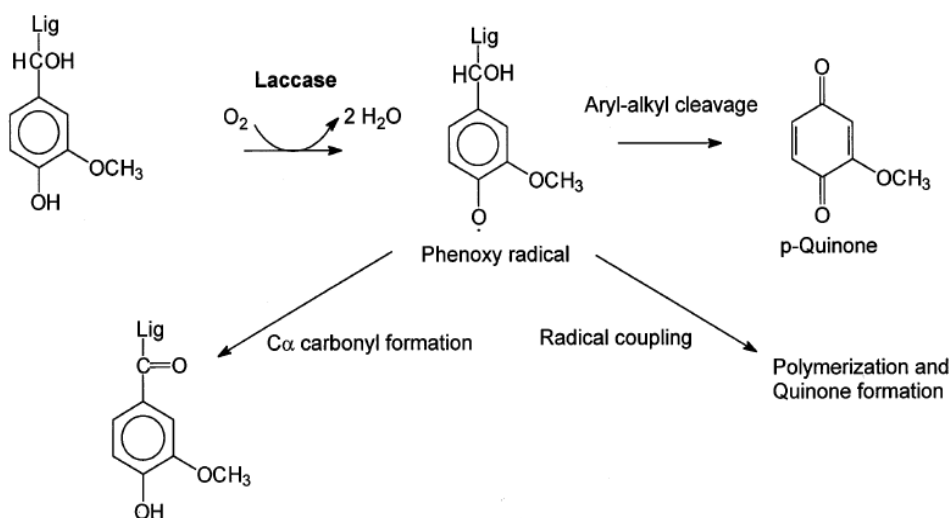

Figure 1.1: Oxidation of phenolic subunits of lignin by laccases (adapted from Archibald *et al.*, 1997).

Thurston (1994) stated in a review that hydroquinone and catechol are good laccase substrates, whereas guaiacol and DMP are often better because these are both methoxy-substituted monophenols. *p*-phenylene diamine is a widely used substrate

and syringaldazine is a unique substrate for laccase. Thus, laccase oxidises polyphenols, methoxy-substituted monophenols, diamines and a vast range of other compounds (Thurston, 1994). *Neurospora crassa* laccase (Germann *et al.*, 1988) only effectively oxidises para and ortho-diphenols with the exception of phloroglucinol. Laccase from *Pyricularia oryzae* prefers phloroglucinol as a substrate rather than other substituted monophenols (Alsubaey *et al.*, 1996). Laccases from *Cerrena unicolor* and *T. versicolor* oxidise meta-substituted phenols but to varying degrees. Laccase from *C. unicolor* oxidises para-substituted phenols to the greatest extent (Filazzola *et al.*, 1999) while *T. versicolor* laccase is capable to oxidise ortho-substituted phenols to the greatest extent (Jolivalt *et al.*, 1999). An immobilised commercial laccase was shown to be able to degrade meta, ortho and para substituted methoxyphenols, chlorophenols and cresols, but these substituted phenols were oxidised in different orders and to different extents (Lante *et al.*, 2000). Many different reactions have been reported to be catalysed by laccases from different fungi. A comparative study concerning properties of fungal laccases indicated that all the laccases in the study had the ability to oxidise methoxyphenolic acids but to different degrees. The oxidation efficiencies of laccases also depend on pH (Bollag and Leonowicz, 1984). Laccases were also shown to be able to decarboxylate vanillic acid to methoxyquinone (Ander and Eriksson, 1978). Two lignin derived hydroquinones, namely 2-methoxy-1,4-benzohydroquinone and 2,6-dimethoxy-1,4-benzohydroquinone were oxidised by laccase from *Pleurotus eryngii* (Guillen *et al.*, 2000). The auto oxidation of the semiquinones produced by the laccase-catalysed reaction leads to the activation of oxygen. 2,6-dimethoxy-1,4-benzohydroquinone was oxidised more efficiently than 2-methoxy-1,4-benzohydroquinone by laccase (Guillen *et al.*, 2000). This correlates to the higher affinity of laccase for DMP than for guaiacol.

Leonowicz *et al.* (Leonowicz *et al.*, 1985) demonstrated that the biotransformation of the complex polymer Peritan-Na might be due to the existing enzymes in the immobilised fungal mycelium fragments. The products of laccase-catalysed reactions

often lead to polymerisation through oxidative coupling. Oxidative coupling reactions of such products result from C-O and C-C coupling of phenolic substrates and from N-N and C-N coupling of aromatic amines (Hublik and Schinner, 2000).

Industrial processes such as paper bleaching produce organochlorine compounds. These compounds include chlorinated phenols, catechols and guaiacols. Laccase from *T. versicolor* has been shown to dechlorinate tetrachloroguaiacol and release chloride ions (Iimura *et al.*, 1996). Laccases from *Trametes villosa* and *Trametes hirsuta* have the ability to modify fatty and resin acids to some extent. The amount of linoleic, oleic and pinolenic acids were reduced in fatty acids and the amount of conjugated resin contained in resin acids was decreased (Iimura *et al.*, 1996). Laccase also has the ability to cleave an etheric bond of the substrate, glycol- β -guaiacyl ether (a model lignin compound). Phenolic compounds that are oxidised very slowly by laccase have recently been used to increase the storage stability of laccase activity from *T. versicolor* (Mai *et al.*, 2000). The increased stability of laccases could have technological importance, as they possess so many potential applications (see section 1.4)

1.2.2 Non-Phenolic Compounds

The rather broad substrate specificity of laccases can be expanded by the addition of small, diffusible compounds acting as redox mediators, especially in the white-rot fungi.

1.2.2.1 *Laccase Redox Mediators*

A mediator is a small molecule that acts as an 'electron shuttle'. Once oxidised by the enzyme generating a strongly oxidizing intermediate, the co-mediator (Medox), it diffuses away from the enzyme pocket and in turn oxidises any substrate that, due to its size, could not directly enter the enzymatic pocket (Figure 1.2) (Banci *et al.*, 1999). An ideal redox mediator must be a good laccase substrate. Its oxidised and reduced forms must be stable but should not inhibit the enzymatic reaction. Redox

mediators have sufficiently high redox potentials and can perform multiple catalytic reactions without chemical degradation (Morozova *et al.*, 2007).

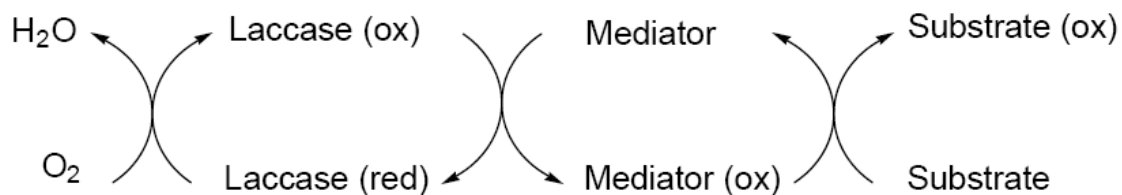

Figure 1.2: Catalytic cycle of a laccase-mediator oxidation system (adapted from Banci *et al.*, 1999).

For instance, in the presence of the suitable redox mediator, 2, 2'-azino-bis-(3-ethylbenzothiazoline-6-sulfonic acid) (ABTS), laccases from *T. versicolor* oxidise non-phenolic model compounds, which are not substrates for laccase alone (Bourbonnais and Paice, 1990, Archibald *et al.*, 1997). The laccase mediator system (LMS) was originally developed to solve problems in bio-bleaching of wood pulps and was firstly described by Bourbonnais and Paice (1990) with the use of ABTS as the first mediator.

Laccases are thought to play a role in the biodegradation of lignin but this is restricted to phenolic compounds because of the low oxidation potentials of these enzymes (Reid and Paice, 1994). Application of these enzymes in the presence of the so-called mediator compounds resulted in high redox potential (>900 mV) leading to the oxidation of nonphenolic lignin model compounds (Figure 1.3). It is suggested that delignification of Kraft pulp with laccase/ABTS system is likely to proceed by a combination of two actions: first, C_α-C_β cleavage of nonphenolic sites in lignin, and second, solubilisation of the lignin fragments by formation of hydrophilic lignin-ABTS. Recently, laccase-catalysed oxidation reaction of ABTS was studied by means

of mass spectrometry and the mechanism was revealed. Under laccase catalysis ABTS formed ions, which could be directly detected using either positive (protonated ABTS, ABTS radical cation, ABTS dication) or negative (ABTS anion, ABTS dianion) ionization mode MS (Marjasvaara *et al.*, 2008). The application of the LMS on hardwood Kraft pulp resulted in reduction of kappa number (lignin number), demethylation and depolymerisation of Kraft lignin (Reid and Paice, 1994, Paice *et al.*, 1995, Archibald *et al.*, 1997).

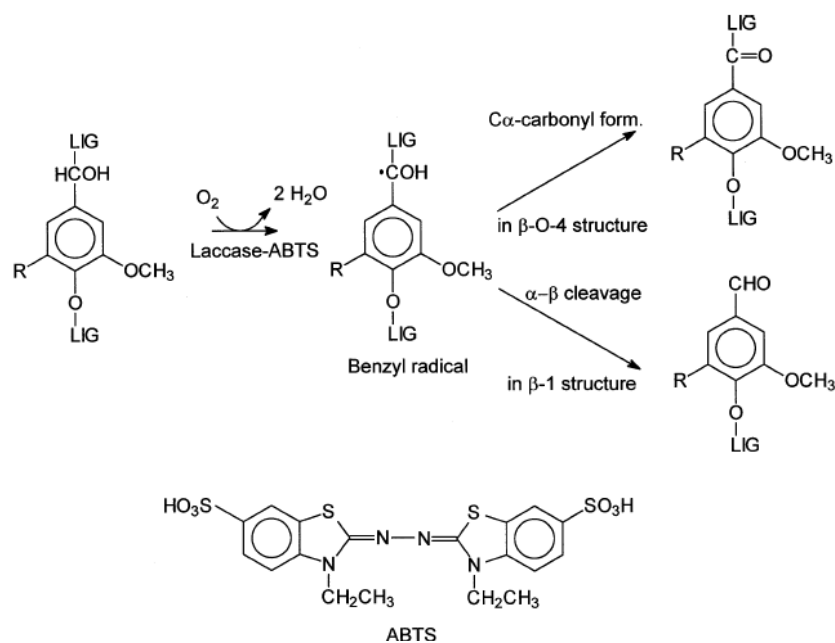

Figure 1.3: Oxidation of non-phenolic lignin subunits by laccases and a mediator ABTS (adapted from Archibald *et al.*, 1997).

Apart from ABTS, 1-hydroxybenzotriazole (HBT) (Figure 1.4) is another mediator that has been widely studied in laccase-mediator system (Bourbonnais *et al.*, 1998).

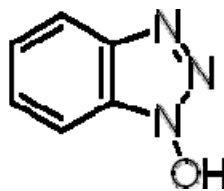

Figure 1.4: Structure of HBT

The LMS was successfully applied to the oxidation of aromatic methyl groups, benzyl alcohols (Johannes *et al.*, 1998), polycyclic aromatic hydrocarbons (Johannes *et al.*, 1998, Majcherczyk *et al.*, 1998, Majcherczyk and Johannes, 2000) and degradation of textile dyes (Hardin *et al.*, 2000). The oxidised mediator can follow an electron transfer, a radical hydrogen atom transfer or an ionic route for the oxidation of substrates.

The activity of a LMS towards lignin is dependant on two main factors. Firstly, the redox potential of the enzyme and, secondly, the stability and reactivity of the radical resulting from the oxidation of the mediator. It has been shown that laccases from different organisms react variably with different mediators and different substrates (Bourbonnais *et al.*, 1997). Approximately 100 different potential mediator compounds have been described for the LMS, but ABTS and HBT remain the most commonly used (Bourbonnais *et al.*, 1997, Majcherczyk and Johannes, 2000)

Recently, further studies have revealed the delignifying action of natural mediators in the LMS. Natural mediators include phenol red, aniline, 4-hydroxybenzoic acid and 4-hydroxybenzyl alcohol (Johannes and Majcherczyk, 2000, D'Acunzo and Galli, 2003). A natural mediator, 3-hydroxyanthranilic acid (HAA) (Figure 1.5), has been detected in the white rot fungus *P. cinnabarinus* culture broth (Eggert *et al.*, 1996a, Geng and Li, 2002). The use of natural mediators has proved to be as efficient as the commonly used ABTS and HBT (Johannes and Majcherczyk, 2000). Phenol red and its derivatives particularly dichlorophenol red are mediators of *Poliporus pinsitus*

laccase. It has been shown that their efficiency in oxidation of the nonphenolic substrate 4-methoxybenzyl alcohol is at least 10 times higher than with HAA (D'Acunzo and Galli, 2003).

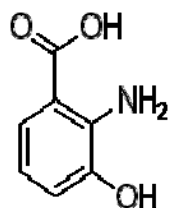

Figure 1.5: Structure of HAA

Morozova *et al.* (2007) also indicated that most compounds described as laccase mediator do not meet requirements imposed on laccase redox mediators. This is due to their electrochemically unstable oxidised intermediates. As a result, only a small number of redox cycles would happen during catalytic oxidation of non-phenolic compounds. Therefore, the term ‘enhancer’ has been accepted as a more precise definition. These compounds, the laccase-mediators or laccase-enhancers, ultimately expand the substrate range of laccases.

1.3 Characterisation of Fungal Laccases

1.3.1 Structure of Fungal Laccases

The majority of laccases characterised so far have been derived from fungi, especially from white-rot basidiomycetes. Almost all species of white-rot fungi are reported to produce laccases in varying degrees and the enzyme has been purified from many species. Up to now, more than 100 laccases have been purified from fungi and been mostly characterised (Baldrian, 2006). Table 1.1 shows a list of purified laccases from basidiomycetes with their individual properties.

Laccases are monomeric, dimeric or multimeric copper-containing enzymes. An example of a multimeric enzyme is the laccase produced by *Podospora anserina*, which has a tetrameric structure with identical subunits. The typical laccase has a relative molecular mass (Mr) of 60 KDa to 80 KDa (Thurston, 1994, Claus, 2003), but there are many exceptions, such as laccases produced by *M. indicum* (Mr = 100 KDa), *Agaricus bisporus* (Mr = 100 KDa), and *Aspergillus nidulans* (Mr = 110 KDa) (Thakker *et al.*, 1992, Perry *et al.*, 1993, Thurston, 1994). An important feature of laccase is a covalently linked carbohydrate moiety (15%-20%), which may contribute to the high stability of the enzyme. There are many reported cases showing that a single fungal species may express more than one laccase isoform (Table 1.1). Different culture conditions may also lead to the production of different isozymes by the same fungus (Yaver *et al.*, 1996, Farnet *et al.*, 1999, Farnet *et al.*, 2000, Palmieri *et al.*, 2003, Shleev *et al.*, 2007).

Table 1.1: Physico-chemical properties of laccases from fungus based on four different substrates ([see Excel attachment](#))

(Slomczynski *et al.*, 1995)

(Fukushima and Kirk, 1995)

(Schneider *et al.*, 2000)

(Heinzkill *et al.*, 1998)

(Shleev *et al.*, 2004) (Smirnov *et al.*, 2001)

(Calvo *et al.*, 1998)

(Dong and Zhang, 2004)

(Edens *et al.*, 1999)

(Litvintseva and Henson, 2002)

(Berka *et al.*, 1997, Bulter *et al.*, 2003)

(Rogalski *et al.*, 1990)

1.3.2 Active Site Property of Laccases

Laccase typically contains four copper atoms in three types per monomeric molecule. Three types of copper can be distinguished using UV/visible and electroparamagnetic resonance (EPR) spectroscopy (Claus, 2003). Type 1 (T1) copper is responsible for the blue colour of the protein. It has a strong electronic absorbance at 610 nm and is EPR detectable; Type 2 (T2) copper does not confer colour in the visible spectrum but reveals paramagnetic properties in EPR studies and Type 3 (T3) copper consists of a pair of copper atoms in a binuclear conformation that gives a weak absorbance at 330 nm in the near UV region but no detectable EPR signal (Thurston, 1994). The T1 copper atom is usually coordinated by two histidines and a cysteine. The axial ligand is methionine-copper ligand in bacterial (CotA) (Figure 1.6), whereas in fungal laccases it is replaced by leucine or phenylalanine. Actually, despite strong similarity in their EPR parameters, the reduction potential of the T1 center can vary widely in different enzymes, from approximately 0.465 V in *Myceliophthora thermophila* laccase to 0.775 V in *T. versicolor* laccase. The redox potentials of the T1 sites in fungal laccases are generally much higher (≈ 0.3 V) than those of plant laccases and other blue copper oxidases (Xu *et al.*, 1996). It has been suggested that the coordination geometry and ligands nature of the T1 copper might determine the redox potential (E°) of this metal. A mutation from phenylalanine to methionine significantly lowered the oxidation potential of a fungal laccase from *T. villosa* (Kumar *et al.*, 2003).

The copper atoms of the T2/T3 sites are coordinated to eight histidines, which are conserved in four His-X-His motifs. The two T3 atoms are coordinated to six of the histidines while the T2 atom is coordinated to the remaining two histidines. A hydroxoxyl ligand bridges the pair of T3 atoms and because of its strong anti-ferromagnetic coupling it is responsible for the phenomenon of the T3 pair being EPR silent (Ducros *et l.*, 1998).

The function of the T1 site in laccase involves electron abstraction from reducing substrates (electron donors) with a subsequent electron transfer to the T2/T3 copper cluster. The T2 and T3 copper atoms form a trinuclear cluster site, which is responsible for oxygen binding and its reduction to water.

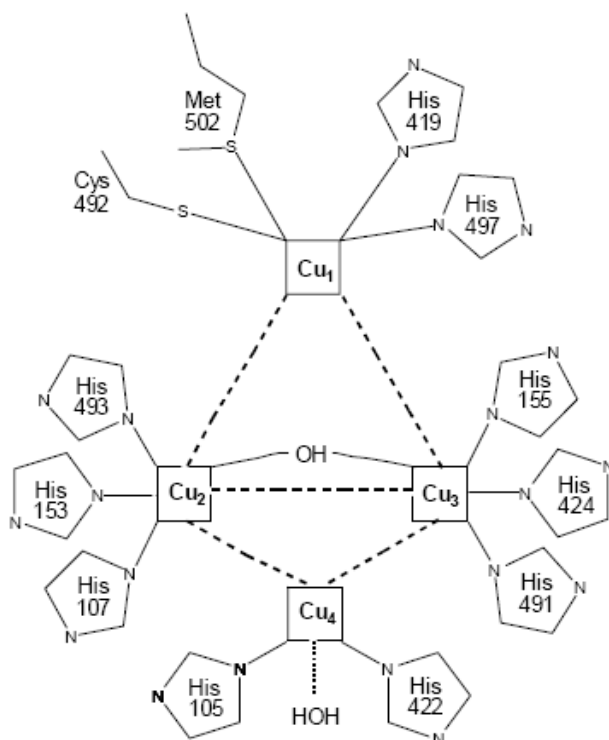

Figure 1.6: Copper centres of the bacterial (CotA) from *B. subtilis* (adapted from Enguita *et al.*, 2003).

1.3.3 Active Site Exceptions

Not all laccases are reported to possess four copper atoms per monomeric molecule (Thurston *et al.*, 1994). The occurrence of laccases which are lack of the typical absorption around 600 nm has been reported. One of the laccases from *P. ostreatus* is shown to confer no blue colour and was described by the author to be a white laccase (Palmieri *et al.*, 1997). Atomic absorption confirmed that the laccase consisted of 1

copper atom, 1 iron atoms and 2 zinc atoms instead of the typical four coppers. Certain laccases, from solid-state and submerged cultures of *Panus tigrinus*, have been found to be yellow or yellow-brown rather than blue (Leontievsky *et al.*, 1997). It was found that yellow laccases and blue laccases from the same organism have similar copper contents. It was proposed that yellow laccases, under normal aerobic conditions, did not maintain their copper centres in the oxidised state of resting enzymes. The binding of low molecular mass phenolic material from lignin degradation could contribute to such a change of enzymatic property (Leontievsky *et al.*, 1997). It was assumed that yellow laccase was formed as a result of blue laccase modification by products of lignin degradation. This further suggests that more complex reaction mechanisms may exist within the same laccase family of enzymes (Mansur *et al.*, 2003, Pozdniakova *et al.*, 2006).

1.3.4 Physico-Chemical Properties of Fungal Laccases

Despite the high biochemical similarity of most laccases, the results of extensive studies have demonstrated that there are diverse physico-chemical properties which not only differ from species to species but also from the same strain within one fungal species.

1.3.4.1 *Michaelis Constant and Catalytic Efficiency Constant*

Michaelis constant (K_m) and the catalytic efficiency constant (k_{cat}) are used to describe the catalytic action of an enzyme. These constants have been measured for a large number of laccases and great variations have been observed among them (Table 1.1). The K_m values of laccases are within the range of 2-500 μM , which is highly dependant on the source of enzymes as well as the substrate applied. The lowest K_m values have been measured with syringaldazine as substrate, which is a dimer of two molecules of 2, 6-dimethoxyphenol linked by an azide bridge. The K_m values of syringaldazine are generally lower compared with those obtained with monomeric

2, 6-dimethoxyphenol.

The stronger affinity of syringaldazine to laccases might be due to the azide bridge or the existing dimer form. The comparison of K_m values also indicates that laccases from different microorganisms have different substrate preferences (Xu *et al.*, 1996).

The catalytic efficiency expressed as k_{cat} is usually characteristic of a specific protein. It represents the rate of catalytic process. Significant variance has been observed in k_{cat} of various laccases even with the same substrates (Table 1.1). Laccases generally show high affinity to the non-natural substrate ABTS and the phenolic compound syringaldazine with high catalytic constant, whereas the oxidation of guaiacol and DMP is considerably slow and the respective K_m constant is comparatively higher. In some cases, for example, the laccases from *Pleurotus sajor-caju*, *Trametes pubescens* and *Trametes trogii*, the k_{cat} values for each single laccase do not differ so much when it reacts with different substrates. It indicates that k_{cat} describes the rate of the electron- transfer reaction after substrate binding . However, the variance in the assay conditions is a factor that must be taken into account when the catalytic constants measured in different laboratories are compared. From Table 1.1, the constants have been measured under varying pH, ionic strength and temperature conditions, as well as applying different concentration of proteins, all of which have great effects on the results.

In addition to the kinetic constants, the catalytic performance of laccases is also described by their activity and stability under different pH and temperature conditions.

1.3.4.2 Effect of pH on Laccase Activity

Fungal laccases typically exhibited optimal pH with the range of 4.0-6.0 (Eggert *et*

al., 1996b). The optimum pH for the oxidation of ABTS is generally lower than 4.0, while the oxidation of phenolic compounds like DMP, guaiacol and syringaldazine show higher pH values between 4.0 and 7.0. When measured using phenolic substrates, the pH profiles of laccases are often bell-shaped (Palmieri *et al.*, 1993, Eggert *et al.*, 1996b, Xu, 1997, Chefetz *et al.*, 1998, Garzillo *et al.*, 1998, Schneider *et al.*, 1999) which is formed by two opposing effects. The decrease in laccase activity in neutral or alkaline pH values is affected by increasing hydroxide anion inhibition, because even though a small anion, hydroxide ion is a laccase inhibitor (Xu, 1997). On the other hand, the oxidation of phenol substrates depends on the redox potential difference between the phenolic compounds and the T1 copper (Xu, 1996, Claus, 2003). The increase of pH decreases the redox potential of the phenolic compounds due to the oxidative proton release, which makes the substrate more susceptible to oxidation by laccases (Xu, 1997). In conclusion, the two opposite effects: increasing ΔE^0 [laccase-substrate] and inhibition by hydroxide anion, lead to the bell-shaped pH profile for phenolic compounds. In the oxidation of non-phenolic substrates, such as ABTS, proton exchange is not involved. Laccases are generally more stable at alkaline pH rather than acidic pH (Xu, 1999). Laccase from *Melanocarpus albomyces* showed good stability at alkaline pH values, over 99% of the activity was preserved after 22 hours' incubation at pH 8.0 (Kiiskinen *et al.*, 2002).

1.3.4.3 Effect of Temperature on Laccase Activity and Stability

Temperature profiles for laccase activity vary considerably, depending on the microorganism. In general, laccases are stable and laccase activity maintains 100% between 50-70°C. Few enzymes with optimum activity below 35°C have been described. *P. ostreatus* POXA2 is stable at 25-35°C (Palmieri *et al.*, 1997) and *Ganoderma lucidum* laccases show the highest activity at 25°C (Ko *et al.*, 2001). However, this has no connection with the optimum temperature of fungal growth.

The typical half life of fungal laccases is clearly below 1 hour at 70°C and below 10 minutes at 80°C (Xu, 1997; Chefetz *et al.*, 1998; Galhaup *et al.*, 2002a). Laccases from *G. lucidum* were immediately inactivated at 60 °C (Kumari and Sirsi, 1972), whereas the thermostable laccase from *M. albomyces* exhibited a half life of over 5 hours and thus has high potential use in biotechnological applications (Kiiskinen *et al.*, 2002)

1.3.5 cDNA and Gene Sequences

The first gene and/or cDNA sequences were recorded for laccase from the ascomycete fungus, *N. crassa* (Germann and Lerch, 1986). Further sequences were published from 1990 onwards. These included laccases from *A. nidulans* (Aramayo and Timberlake, 1990), *Coriolus hirsutus* (Kojima *et al.*, 1990), *Phlebia radiata* (Saloheimo *et al.*, 1991), *A. bisporus* (Perry *et al.*, 1993), *G. lucidum*, *Phlebia brevispora*, *Lentinula edodes*, *Lentinus tigrinus* (D'Souza *et al.*, 1999), *P. anserina* (FernandezLarrea and Stahl, 1996), *T. versicolor* (Jönsson *et al.*, 1997), *P. cinnabarinus* (Eggert *et al.*, 1998) and *Coprinus congregatus* (Leem *et al.*, 1999), *P. ostreatus* (Giardina *et al.*, 1999). The sequences mostly encoded polypeptides of approximately 520 to 550 amino acids (including the N-terminal secretion peptides). The one cysteine and ten histidine residues involved in the binding of copper atoms were conserved for laccases and this is also similar to what is found for sequences from ascorbate oxidase. The difference between laccases and ascorbate oxidase in the copper-binding region is that ascorbate oxidase exhibits the presence of a methionine ligand, which is not present in the laccase sequences. The absence and presence of the methionine ligand has led to mutagenesis studies conducted by Xu and coworkers (Xu *et al.*, 1998, Xu, 1999)

1.3.6 Mutagenesis of the Active Site

Various models have been generated to correlate the copper site structure and the

molecular properties of laccase. In particular, it has been postulated that the coordination geometry and ligands of the Type 1 copper might determine the redox potential of this site. Many laccases were shown to have a leucine or methionine residue at the position corresponding to that of the T1 copper site (Aramayo and Timberlake, 1990; Thurston, 1994; Ducros *et al.*, 1998; Leontievsky *et al.*, 1997). Xu *et al.* (1998) observed that *T. versicolor* laccase that has a high redox potential (0.8 V) presented a phenylalanine residue instead of methionine or leucine and predicted that it might be responsible for the high redox potential. In 1996, Xu and his co-workers showed that three high redox laccases had a leucine-glutamate- alanine tripeptide, rather than the valine-serine- glycine tripeptide found in low redox laccases. The position of the tripeptide corresponds to the T1 pocket and serves as part of the substrate-binding pocket (Xu *et al.*, 1996). The results of the triple mutation on the redox potential, suggest that the substrate binding pocket and the electron transfer pathway from the substrate to the T1 copper were affected. They thus proved that it might be possible to regulate laccase catalysis by targeted engineering (Xu *et al.*, 1998). A pentapeptide was also targeted in the vicinity of the T1 copper site of a low and a high redox laccase. A leucine residue was replaced by a phenylalanine residue at the position corresponding to the T1 copper axial ligand. No significant effects could be elucidated (Xu *et al.*, 1998).

1.4 Application of Laccases

Oxidation reactions are widely used in industrial processes, such as in the textile, food, wood and paper processing, pharmaceutical and chemical industries. However, the current oxidation methods such as using oxidant oxygen, chlorine, ozone and hydrogen peroxide in these industries are neither economically satisfactory nor environmentally friendly. The reaction catalysts are often toxic and some are carcinogenic. Moreover, unwanted side reactions and oxidants are often generated

along with processes. Therefore, the search for efficient and oxidation technologies to replace the conventional non-biological methods becomes necessary.

Oxidant enzymes prove to be specific, efficient and ecologically sustainable catalysts in oxidation reactions, therefore enzymatic oxidation has the potential to replace the traditional chemical methods. Among existing oxidant enzymes, laccases have become interesting enzymes for industrial oxidation processes due to their capability of oxidizing a wide variety of substrates. In addition, laccases use readily available molecular oxygen as an electron acceptor instead of expensive cofactors, such as NAD(P)⁺.

Laccases have a wide range of applications, not only in pulp bleaching and delignification (Archibald *et al.*, 1997), but also in the detoxification of lignocellulose hydrolysates for ethanol production by yeast, treatment of wastewater from industrial plants (Palmqvist and Hahn-Hagerdal, 2000), enzymatic removal of phenolic compounds in beverages (Minussi *et al.*, 2002), enzymatic modification of fibres and dye-bleaching in the textile and dye industries, construction of biosensors and textile dye transformation (Xu, 1999). Some examples of the role of laccases in oxidation processes are given below.

1.4.1 Delignification and Pulp Bleaching

Lignin is a major component of wood. Because of the importance of wood and other lignocellulosics as renewable resources for paper products, feeds, chemicals and fuels (D' Souza *et al.*, 1999), increasing research emphasis has been put on white rot fungi due to their efficient enzyme mechanisms employed in lignin biodegradation. Laccase is particularly abundant in many white rot fungi, which are believed to be the most effective lignin-degrading microbes in nature. The substrates of laccases are not

limited to phenol subunits but also extended to non-phenolic lignin constituents together with mediators. In the case of *P. cinnabarinus* enzyme system, laccases were described as the single predominant enzymes that were capable of lignin degradation, and neither lignin-, nor manganese-type, peroxidase were produced. *P. cinnabarinus* provides an ideal model to develop a laccases-based treatment of pulp bleaching, which represents the first promising biotechnological application of a process based on a single ligninolytic enzyme (Eggert *et al.*, 1997). Laccases are able to de-lignify pulp when they are used together with mediators (Bourbonnais and Paice, 1992, Morozova *et al.*, 2007). Although the laccase-mediator system has been extensively studied, there are still problems unresolved, including mediator recycling, cost and toxicity.

1.4.2 Dye Degradation

In textile industry, a single dyeing operation may use a number of dyes from different chemical classes resulting in a very mixed wastewater. Approximately 100,000 different dyes and pigments are produced annually worldwide and used extensively in the textile, dyeing and printing industry. Product processing methods often cause a loss of large amounts of dyes to wastewaters, representing 10-15% of the dyes applied. Several of these dyes are very stable to light, temperature and microbial attack, making them recalcitrant compounds, many of them are even toxic (Robinson *et al.*, 2001). Dyes are often recalcitrant organic molecules that impose strong colour to the wastewater and lead to the enhancement of organic load and toxicity of the wastewater. The greatest environmental concern with dyes is that they absorb and reflect sunlight entering the water, which interferes with the growth of algae. This property of dyes greatly limits biodegradation levels of impurities in the water (Cristovao *et al.*, 2009). As a result, there has been emphasis on colour removal from dye-containing effluents from both environmental and commercial point of view.

1.4.2.1 Dye Classification

All molecules absorb electromagnetic radiation, but differ in the specific absorption wavelengths. Some molecules have the ability to absorb light in the visible spectrum (400-800 nm) and, as a result, they are themselves coloured. Dyes are molecules with delocalised electron systems with conjugated double bonds which contain two groups: the chromophore and the auxochrome. The chromophore comprises a group of atoms, which controls the colour of the dye, and it is usually an electron-withdrawing group. The most important chromophores are $-C=C-$, $-C=N-$, $-C=O$, $-N=N-$, $-NO_2$ and $-NO$ groups. The auxochrome is an electron-donating substituent that can intensify the colour of the chromophore by altering the overall energy of the electron system and provides solubility and adherence of the dye to the fibre. The most important auxochromes are $-NH_2$, $-NR_2$, $-NHR$, $-COOH$, $-SO_3H$, $-OH$ and $-OCH_3$ groups (Andrea, 2005). Based on chemical structure or chromophore, 20-30 different dye groups can be identified. Azo (monoazo, disazo, triazo, polyazo), anthraquinone, phthalocyanine and triarylmethane dyes are quantitatively the most important chromophores (Figure 1.7).

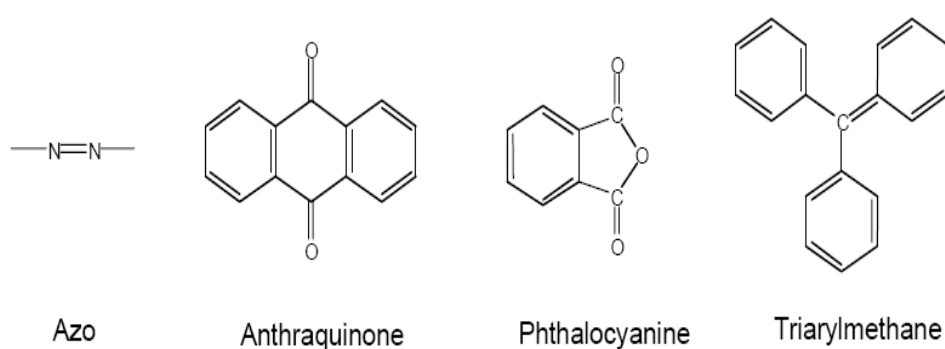

Figure 1.7: The most important chromophores.

Most of the commercial dyes are classified in terms of colour, structure or method of application in Colour Index (C.I.), which is edited every three months since 1924 by the "Society of Dyers and Colourists" and the "American Association of Textile Chemists and Colourists". The last edition of the Colour Index lists about 13,000

different dyes. Each dye is assigned to a C.I. generic name determined by its application and colour. The 15 Colour Index different application classes are listed in Table 1.2.

Table 1.2: Colour Index application classes (Christie, 2001).

Application Class	Characteristics
Acid dyes	High water solubility due to the presence of sulphonic acid groups. Form ionic interactions between the protonated functionalities of the fibers ($-\text{NH}_3^+$) and the negative charge of the dyes. Also Van-der-Waals, dipolar and hydrogen bonds are formed. The most common structures are azo, anthraquinone and triarylmethane.
Reactive dyes	Form covalent bonds with $-\text{OH}$, $-\text{NH}$ or $-\text{SH}$ groups in cotton, wool, silk and nylon. The problem of coloured effluents associated to the use of these dyes is due to the hydrolysis of the reactive groups that occurs during the dyeing process. The most common structures are azo, metal complex azo, anthraquinone and phthalocyanine.
Direct dyes	Their flat shape and length enables them to bind alongside cellulose fibers and maximize the Van-der-Waals, dipole and hydrogen bonds. Only 30% of the 1600 structures are still in production due to their lack of fastness during washing. The most common structures are almost always sulphonated azo dyes.
Basic dyes	Basic dyes, work very well on acrylics due to the strong ionic interaction between dye functional groups such as $-\text{NR}_3^+$ or $=\text{NR}_2^+$ and the negative charges in the copolymer. The most common structures are azo, diarylmethane, triarylmethane and anthraquinone.

1.4.2.2 Dye Degradation

There are various treatments of dye-containing effluents based on chemical and physical procedures, such as adsorption, ion-exchange, chlorination/ozonation and incineration. These methods are usually quite costly and sometimes generate hazardous by-products (Shaul *et al.*, 1991).

Enzyme-based process proves to be economic and environmentally friendly. It offers minimal impact on environment and has low energy requirements. Additionally, enzymes can operate under wide pH range, at moderate temperature or ionic strength and are active in the presence of organic solvents (Torres *et al.*, 2003).

Many white rot fungi (such as *P. chrysosporium*, *P. sajor-caju*, *T. versicolor*, *Bjerkandera sp. BOS55*, *etc.*) have demonstrated their ability to degrade a variety of synthetic dyes, which have been attributed to the extracellular activity of oxidative enzymes (Morgan *et al.*, 1991). However, the mechanism involved in degradation by white rot fungi is not completely determined and this knowledge could be quite useful for biodegradation process design and optimization. Most previous studies have focused on the lignin-degrading enzyme systems from *P. chrysosporium* and *T. versicolor*. *P. chrysosporium* can degrade a wide range of recalcitrant xenobiotic compounds, including azo dyes (Cripps *et al.*, 1990, Chao and Lee, 1994). However, it showed faster degradation rate when an alternative carbon source, such as cellulose, was also present in the culture medium (Fernando *et al.*, 1989). *P. chrysosporium* decolourised azo dyes extensively under low-nitrogen condition (Spadaro *et al.*, 1992), whereas in the case of *Ganoderma australe*, *P. ostreatus sp.3* and *P. ostreatus sp.4*, high levels of colour removal efficiency was observed in nitrogen-rich medium (Rigas and Dritsa, 2006).

Under solid-state culture conditions, *P. chrysosporium* partially decolourised amaranth, new coccine, orange G and tartrazine, while *P. sajorcaju* totally decolourised all mentioned dyes except for tartrazine. Different results were obtained in liquid culture medium for these two white rot fungi. *P. chrysosporium* totally decolourised amaranth, new coccine, orange G and 60% tartrazine. *P. sajorcaju* totally decolourised amaranth, new coccine, 50% orange G and 20% tartrazine (Chagas and Durrant, 2001).

Decolourisation by *T. versicolor* 20869 pellets has proved to be several times faster compared with that by *P. chrysosporium* and it has shown to secrete MnP and laccase during dye decolourisation in batch culture on modified Kirk medium (Swamy and Ramsay, 1999).

Real textile effluents are extremely variable in composition as they contain not only dyes but also salts at very high ionic strength and extreme pH values, chelating agents, precursors, by-products and surfactants that can inhibit enzyme activity and decolourisation (Abadulla *et al.* 2000). Therefore, decolourisation of textile effluents requires an appropriate choice of the type of enzymes as well as of reactor environment (Wesenberg *et al.* 2003). Recently, increasing attention has been paid to laccases because of their ability to act on chromophore compounds such as azo, thiarylmethane, anthraquinonic and indigoid dyes, which leads to the suggestion that they can be applied in industrial decolourisation processes. However, these processes have been prevented from wide application due to unfavourable kinetics between the enzyme and the dye. It has been proved that the addition of small molecules, generally known as 'redox mediators', facilitates the decolourisation process of certain dyes. Therefore, the usage of mediators provides better solution in recalcitrant dyes treatments.

In addition to dyestuff wastewater, laccases can also efficiently decolourise wastewater from olive oil mill (Jaouani *et al.*, 2004, Jaouani *et al.*, 2006) and pulp mills or waste from other industries containing chlorolignins or phenolic compounds. The enzymes render phenolic compounds less toxic via degradation or polymerisation reactions and/or cross-coupling of pollutant phenols with naturally occurring phenols (Abadulla *et al.*, 2000).

1.4.3 Bioremediation

Another potential environmental application for laccases is the bioremediation of contaminated soils (Duran and Esposito, 2000); laccases are able to oxidize toxic organic pollutants, such as polycyclic aromatic hydrocarbons (Collins *et al.*, 1996) and chlorophenols (Gianfreda *et al.*, 1999, Ahn *et al.*, 2000). The most useful method for this application is to inoculate the soil with fungi, which are efficient laccases producers, because it is not economically feasible to directly apply isolated enzymes for soil bioremediation on a large scale.

1.5 **Production of Laccases**

To utilize laccases more efficiently for their biotechnological and environment-related applications and to better understand the properties of these important enzymes at a molecular and kinetic level, rather large amount of crude and purified laccases at low cost are required.

Reducing the cost of laccase production by optimising the fermentation medium is the basic research for industrial application. White rot fungi are considered to be excellent producers of laccases. The physiological requirements of different white rot fungi are varied. Hence, considerable researches have been carried out on the

influence of carbon source, nitrogen source and concentration, pH, and other culture conditions on laccase production (Wesenberg *et al.*, 2003).

1.5.1 Effect of Carbon Source and Concentration on Laccase Production

Carbon sources as well as its concentration in the medium play an important role in ligninolytic enzyme production. Various basidiomycetes grown in sugar-rich liquid medium were compared for laccase-producing ability. It was found that an excess of glucose or saccharose in the liquid medium eliminated the induction of laccases, where the constitutive production of laccases is maintained but the biosynthesis of induced laccases is repressed by both sugars (Bollag and Leonowicz, 1984).

It was shown that the use of fructose instead of glucose led to 100-fold increase in the specific laccase activity produced by basidiomycete strain I-62 (CECT 20197) (*Polyporaceae* family) (Mansur *et al.*, 1997). When the effect of four carbon sources (maltose, glucose, fructose, and sucrose) was examined in laccase production by *P. sanguineus*, it was found that the volumetric and specific activities of laccase decreased in the following order: fructose>sucrose>glucose>maltose. Fructose was more efficient than glucose in laccase production by *P. sanguineus*. In addition, the results indicated that monosaccharides were more efficient than the equivalent disaccharides. Thus, laccase decreased in the following sequences: fructose>sucrose and glucose>maltose (Eugenio *et al.*, 2009). In another study where glucose was used as a carbon source, laccase activity was not detectable in the cultivation of *P. chrysosporium*. However, when glucose was replaced by cellulose, which is a less readily available carbon source, laccases were produced in both high nitrogen-cellulose and low nitrogen-cellulose media (Srinivasan *et al.*, 1995).

Moreover, in the case of *T. versicolor* KCTC 16781 cultures, an increased laccase activity was found with glucose compared to fructose and sucrose as carbon sources (Lee *et al.*, 2006). More recently, Stajić *et al.* investigated the effect of glucose and

maltose on laccase by selected *Pleurotus* strains, including *P. eryngii* 616 and *P. ostreatus* 493 and 494 cultures and found that laccases activity was higher in medium containing glucose than maltose (Stajic *et al.*, 2006). All these findings suggest that the optimum carbon source depends on the particular fungus in each case. It has been observed that glucose concentration plays significantly effect on laccase production by *P. tigrinus* and *T. pubescens* (Quaratino *et al.*, 2008). Although its inhibitory effect has been observed in *T. pubescens*, glucose is still employed as carbon source for laccase production. This was due to the poor growth on other carbon sources studied, such as lactose and cellulose. In addition, the same invetstigators reported that the repression of the main laccase gene, *i.e.* *lap2*, was repressed when glucose concentration exceeds about 1 g/l and an early onset of laccase activity was obtained when fractorse was used to replace glucose (Galhaup *et al.*, 2002b). Same results was obtained in *P. sajor-caju* PS-2001 stain that fructose and glucose led to higher laccase activity compared to sucrose and lactose. The data also showed that significant higher values of laccase activity in the medium containing low concentration of carbon source (Bettin *et al.*, 2009).

1.5.2 Effect of Nitrogen Source and Concentration on Laccase Production

On the other hand, some authors have found that laccase production not only depends on the nitrogen source used but also on the nitrogen concentration.

Four different nitrogen sources (ammonium tartrate, sodium nitrate, asparagine and yeast extract) were used to examine their effect on volumetric and specific activities of laccase from *P. sanguineus*. Laccase efficiency decreased in the following sequence of nitrogen sources: asparagine > ammonium tartrate > yeast extract > sodium nitrate (Eugenio *et al.*, 2009). The findings of nitrogen source were consistent with the previous report on *T. versicolor* KCTC 16781 cultures, where asparagine was found to be better nitrogen source compared to sodium nitrate (Lee *et al.*, 2006).

However, in latter case, laccase activity obtained with yeast extract was less than that in sodium nitrate. This also suggests that the best nitrogen source varies for laccase production by different fungi.

Laccase production can be influenced by the nitrogen concentration in the culture medium. Ligninolytic systems of white-rot fungi get activated mainly during the secondary metabolite production and are often stimulated by nitrogen depletion (Keyser and Kirk, 1978), such as *P. cinnabarinus* (Eggert *et al.*, 1996b) or *P. sanguineus* (Pointing *et al.*, 2000). However, it is also found that the regulation of ligninolytic activity by nitrogen source limitation is not a universal phenomenon among white rot basidiomycetes (Leatham and Kirk, 1983). It has been reported that the level of laccase activity produced in high-nitrogen media is greater than that in low-nitrogen culture when *Lentinela (Lentinus) edodes* and *G. lucidum* were studied (Buswell *et al.*, 1995, D'Souza *et al.*, 1999). High nitrogen content of the medium has been shown to induce transcription of laccase genes in the basidiomycete I-62 (CECT 20197) (Mansur *et al.*, 1997) and *P. sajor-caju* (Soden and Dobson, 2001). On the other hand, an increase from 2.0-12.5 g/l in ammonium tartrate resulted in a marked delay in the time required to attain the laccase activity peak in the *P. tigrinus* strain (Quarantino *et al.*, 2008).

1.5.3 Effect of Inducers on Laccase Production

In white rot fungi, low concentrations of extracellular laccases are produced constitutively when fungi are grown on wood and in submerged cultures. However, laccase production can be considerably stimulated by the presence of a wide variety of inducing substances, mainly aromatic or phenolic compounds related to lignin or lignin derivatives, such as ferulic acid, 2, 5-xylidine and veratryl alcohol (Bourbonnais *et al.*, 1995).

Many aromatic compounds as shown in Figure 1.8 have already been introduced as inducers for production of laccases by various white rot fungi. The effect of 2, 5-xylydine was first described by Fahraeus *et al.* in 1958 for the white-rot fungus *T. versicolor*. Over 160-fold stimulation of laccase activity was found when 2, 5-xylydine was added in the fungal growth medium (Fahraeus *et al.*, 1958). Moreover, this type of compound was also reported to be an effective inducer in other lignin-degrading fungi such as *P. cinnabarinus* (Eggert *et al.*, 1996b) and *P. radiate* (Rogalski *et al.*, 1991). In the case of *P. cinnabarinus*, 2, 5-xylydine enhanced laccase production 9-fold without altering the isoenzyme pattern of the enzyme (Eggert, *et al.*, 1996b). In other fungi, such as *Trichophyton rubrum* LKY-7, 2.5 μ M of 2,5-xylydine slightly enhanced laccase production (Jung *et al.*, 2002) and in the cultures of *T. versicolor*, 2, 5-xylydine led to the highest laccase activity compared to other inducers (Rancano *et al.*, 2003). New laccase-isozyme patterns are often induced by xylydine in cultures of *T. villosa* (Yaver *et al.*, 1996). Laccase isozyms can be ascribed to laccase gene family or to post translational modification of a single protein. However, it has been reported that production of laccases by basidiomycete PM1 (CECT 2971) was not induced by 2,5-xylydine (Coll *et al.*, 1993).

Other aromatic compounds were also found to stimulate laccase production. Ferulic acid considerably induces laccase production in the culture of *P. ostreatus*, *T. versicolor* (Leonowic.A *et al.*, 1972) and *P. sajor-caju* (Lo *et al.*, 2001). Another inducer, gallic acid, was reported to enhance the production of laccases from *B. cinerea* (Fortina *et al.*, 1996).

Veratryl (3, 4-Dimethoxybenzyl) alcohol is another aromatic compound known to play an important role in enzymatic degradation of lignin (Zapanta and Tien, 1997). The addition of veratryl alcohol to cultivation medium of a lignin-degrading basidiomycetes I-62 resulted in a 10-fold increase in laccase activity (Mansur *et al.*,

1997).

Certain inducers that are structurally related to lignin precursors, such as 2, 5-xylydine and ferulic acid, have shown to increase the level of laccase genes transcription in *T. villosa*, *T. versicolor* and *P. sajor-caju* (Yaver *et al.*, 1996, Collins and Dobson, 1997, Soden and Dobson, 2001). Moreover, it is shown that *T. villosa* and *P. sajor-caju* contain constitutively expressed genes, which may be related to different physiological roles of various laccases played in these fungi (Collins and Dobson, 1997, Soden and Dobson, 2001).

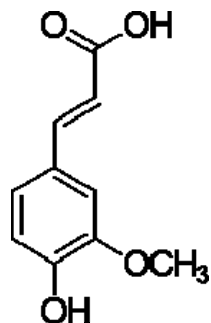

Ferulic acid

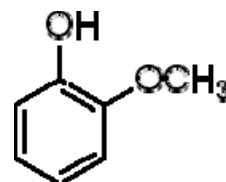

Guaiacol

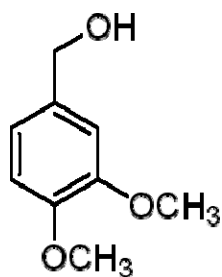

Veratryl alcohol

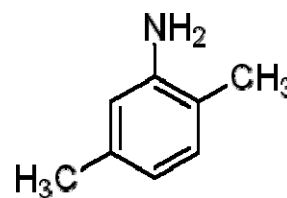

2, 5-Xylydine

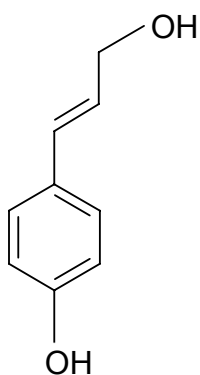

p- Coumaryl alcohol

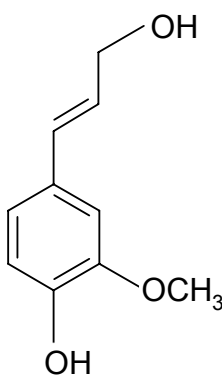

Coniferyl alcohol

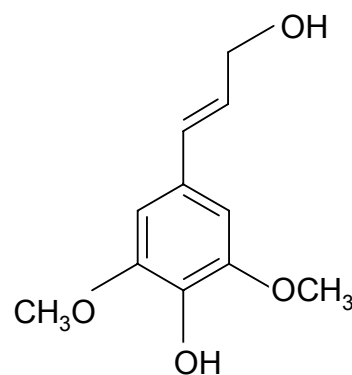

Sinapyl alcohol

Figure 1.8: Chemical structures of lignin-derivatives and monolignol structures.

The inducers are mostly aromatic compounds which are harmful to the human body, or otherwise expensive. The limitation of application in industry is therefore obvious. Due to the large range of applications of the laccases, the development of an environmentally friendly and economically feasible compound that can enhance the production of laccase attracts significant interest.

Addition of different insoluble lignocellulosic materials including grape seeds, grape stalks and barley bran, into the culture medium was studied in order to enhance laccase production by the white-rot fungus *T. versicolor* (CBS100.29) in submerged cultures. Barley bran resulted in the highest activity, which was 10 times the value attained in the cultures without lignocellulosics addition. The agro-industrial wastes are abundant in most countries and are very likely to replace the aromatic compounds, such as ferulic acid, 2,5-xylydine, veratryl alcohol, because of their availability and low cost (Lorenzo *et al.*, 2002).

In-Young Lee (1999) found that production of laccases in the production medium was 20 times higher with the addition of ethanol to the culture, the effect of which can be comparable to those well-known inducers such as veratryl alcohol, as well as xylydine and guaiacol (Lee *et al.*, 1999). Meza *et al* (2007) demonstrated that ethanol acts as an inducer for laccase-gene expression in the case of the white rot fungus *P. cinnabarinus* (Meza *et al.*, 2007). The authors reported a regulatory role in both gene expression and protease-activity levels, which were both in favour of an increase in laccase production by the fungus.

In the work performed by Moredo, *et al.* (2003), laccase production by the white-rot fungus *T. versicolor* pre-cultivated with different insoluble lignocellulosic materials (grape seeds, barley bran and wood shavings) was investigated. These lignocellulosic materials consist of a broad range of wastes from agricultural and forest industries

and are mainly composed of polysaccharides (cellulose and hemicellulose) and lignin. It was found that laccase activity reached its maxima when *T. versicolor* was precultivated with grape seeds and barley bran (Moredo *et al.*, 2003).

Laccase production by a number of white-rot fungi can be enhanced by the addition of ion metals. Copper is often reported as a strong inducer in laccase production by white rot fungi. The induction effect has been explained as a defence mechanism against oxidative stress caused by free copper ions (Collins and Dobson, 1997, Palmieri *et al.*, 2000, Soden and Dobson, 2001, Baldrian, 2006). Besides copper, other metal ions such as Cd^{2+} , Zn^{2+} , Mn^{2+} , Ag^+ , have also been reported to induce laccase activity in different white-rot fungi. Furthermore, these metals have been shown to influence the formation of different laccase isoforms in *T. versicolor* (Lorenzo *et al.*, 2002). Response of white rot fungi to toxic metal include the synthesis of either melanin-like polymers with chelating properties or metallothioneines, absorption onto cell wall polymers and production of oxalic acid (Baldrian, 2003).

The formation of laccases induced by aromatic compounds and metal ions at the level of gene transcription level has been suggested to be due to the existence of various response element sites in the promoter regions of laccase genes. In addition, putative heat-shock elements (HSE), xenobiotic response elements (XRE) and antioxidant response elements (ARE) have been also discovered in the promoter regions of laccases genes, although the roles of these regulatory regions have not been experimentally demonstrated. However, high concentrations of laccases have also been observed in non-induced cultures (Bourbonnais *et al.*, 1995).

1.5.4 Effect of pH

There is little information related to the influence of pH on laccases production; it has been reported that when fungi are grown in a medium with optimal pH, laccases will be produced in excess (Thurston, 1994). Most reports indicate the initial pH value of the medium before inoculation ranging between pH 4.5 and pH 6.0, but the pH is not generally controlled during cultivation (Arora and Gill, 2001). Highest level of laccase activity has been obtained in media with initial pH between 6.0 and 6.5 in fermentation of *P. ostreatus* DM-1513 (Medeiros *et al.*, 1999). The optimum initial pH was determined to be 6.95 for *Trametes modesta* (Nyanhongo *et al.*, 2002).

1.5.5 Effect of Temperature

It has been shown that the optimal temperature for fruiting body formation and laccases production is 25°C in the presence of light, but 30°C when fungi are incubated in the dark. Fungi are generally cultivated at temperatures between 25 °C and 30°C for optimal laccases production (Thurston, 1994). The effect of temperature on laccase production by *T. modesta* was assessed, resulting in 30°C to be the optimum incubation temperature (Nyanhongo *et al.*, 2002).

Considering various factors, such as carbon and nitrogen sources as well as inducers, the selection of medium composition becomes an important step in the design of an efficient and economic process. Table 1.3 summarises reported media compositions for laccase production by different species of white rot fungi.

Table 1.3: Substrates reported on the laccase production by different species of white rot fungi.

Strain	Medium composition per litre
<i>Cerrena maxima</i> (Koroleva et al., 2001)	- Peptone 3g, glucose 10g, KH ₂ PO ₄ 0.6g, ZnSO ₄ 0.001g, K ₂ HPO ₄ 0.4g, FeSO ₄ 0.0005g, MnSO ₄ 0.05g, MgSO ₄ 0.5g.
<i>Coriolopsis polyzona</i> (MUCL 38443) (Jaouani et al., 2006)	<p>- Glucose 10 g, nitrogen 20 mM (L-tartric acid diammonium salt), KH₂PO₄ 1g, yeast extract 0.005g, veratryl alcohol 0.4 mM, Tween-80 0.5g</p> <p>- Glucose 10 g, nitrogen 2.2 mM (L-tartric acid diammonium salt), KH₂PO₄ 1g, yeast extract 0.005g, veratryl alcohol 0.4 mM, Tween-80 0.5 g</p> <p>- Glucose 10 g, nitrogen 2.2 mM (L-tartric acid diammonium salt), KH₂PO₄ 1g, yeast extract 0.005g, veratryl alcohol 0.4 mM, Tween-80 0.5 g, and 100 µM Mn²⁺ (Glucose-based medium were buffered with 20 mM di-sodium tartrate, pH 5.2)</p>
<i>T. versicolor</i> (Thiruchelvam and Ramsay, 2007)	<p>- Malt extract 20 g, veratryl alcohol, 0.4 mM, Tween-80, 0.5 g - Glucose 10 g, ammonium tartrate 2 g, KH₂PO₄ 0.2 g, MgSO₄ ·7H₂O 0.05 g, CaCl₂ ·2H₂O 0.01 g,</p> <p>Thiamine 1 µg, mineral solution 0.1 ml.</p> <p>The trace mineral solution (per liter): MgSO₄ ·7H₂O, 30 g, NaCl 10 g, MnSO₄·H₂O 5 g, CoSO₄ ·7H₂O 1 g, FeSO₄ ·7H₂O 1 g, ZnSO₄·7H₂O, CaCl₂ 0.82 g, CuSO₄ ·5H₂O 0.1 g, NaMoO₄· 2H₂O 0.1 g, H₃BO₃, 0.1 g, EDTA 1g</p>

Strain	Medium composition per litre
<i>Trametes multicolor</i> MB 49 (Hess <i>et al.</i> , 2002)	- Glucose 20 g, yeast extract 5 g, peptone 5 g, MgSO ₄ · 7H ₂ O 1 g The pH was adjusted to 5.0 with H ₃ PO ₄ before sterilisation.
<i>P. sanguineus</i> (MUCL 41582) (Trovaslet <i>et al.</i> , 2007)	- Malt extract 20 g

1.5.6 Elicitation

Elicitors are defined as substances, which have the capability to increase the concentration of specific metabolites through biosynthesis in a variety of biological systems when supplied to the cultures at small concentrations.

As early as 1970s, the initial studies of elicitors were carried out in plant systems. One of the most important defensive systems in plants against the pathogen attack is the production of phytoalexins (Keen, 1975). Oligosaccharides and peptides produced by invading plant pathogen were reported to act as elicitors to induce the production of antimicrobial phytoalexins in the plant system (Albersheim *et al.*, 1977).

Various elicitors have been isolated from plant pathogenic microorganisms. These include peptides (West, 1981), enzymes such as polygalacturonases and pectate lyases (Lee and West, 1981), yeast extract and fungi cell walls (Hamerski *et al.*, 1990, Kim and Yoo, 1996), however, the elicitors of metabolites produced from microorganisms have generally been shown to be polysaccharides or oligosaccharides (Albersheim *et al.*, 1992). Extensive research has been carried out to investigate an inexpensive and economical approach for enhancement of secondary metabolites production using oligosaccharides as elicitors (Radman, 2002) Elicitation research becomes potentially important for enhancement of secondary metabolites of industrial relevance, which will lead to great economic viability.

In recent years, investigation of the effects of elicitation has been extended in diverse biological systems, including fungal cultures. In these fungal cultures, elicitation is focused on the use of carbohydrates derived mainly from sodium alginate and locust-bean gum. Examples are oligogulonate (OG), oligomannuronate (OM) and mannan oligosaccharides (MO) (Radman *et al.*, 2003). The overproduction of secondary metabolites of penicillin G by *Penicillium chrysogenum* was achieved in presence of the oligosaccharides derived from the natural polysaccharide alginate (Ariyo *et al.*,

1997) . In 1997, it was reported that the yield of penicillin G had increased by 50% with the addition of oligosaccharides (guluronate and mannuronate), which were derived from locus bean gum (Ariyo *et al.*, 1997). Similar enhancement in the formation of enzymes and other metabolites was also observed in other fungal strains and species. Glucose oxidase was found to produce in excess by *Penicillium variable* P16 in the presence of oligosaccharides (Petruccioli *et al.*, 1999). The addition of acid-hydrolyzed alginate oligosaccharides and enzyme hydrolyzed pectin oligosaccharides to the wild-type *P. chrysogenum* cultures (ATCC 9480) resulted in enhanced production of the yellow pigment chrysogenin (Asilonu *et al.*, 2000).

The enhancement of secondary metabolites in plants and fungi by elicitors has been suggested to involve the organisms' defence system (Radman *et al.*, 2003). It was proposed that white rot fungi exhibit defence mechanisms under the influence of different types of inducers (see section 1.5.3). Therefore, it is worthwhile to investigate the effect of elicitors on laccase production by white rot fungi, which might provide an alternative method for laccase overproduction.

1.5.7 Recombinant Technology in Laccase Production

Another approach to reduce the costs of laccase production is to overproduce them in a suitable host. However, ligninolytic enzymes are generally difficult to overexpress heterologously in an active form (Kojima *et al.*, 1990). Laccases are preferably produced by wild type strains of white rot fungi due to their glycosylation mechanism involved in the stabilisation process against proteolysis (Yoshitake *et al.*, 1993). Therefore, it is necessary to express these enzymes in eukaryotic microorganisms that are able to carry out post-translational modification. Yeasts are suitable as host expression system for heterologous protein production, because they possess high growth capacity and are eukaryotic microorganisms with the ability of post-translational modifications. Yeasts are also unicellular organisms that are easily manipulated. Detection of active recombinant laccase has been reported in the yeast

Saccharomyces cerevisiae (Kojima *et al.*, 1990, Kiiskinen and Saloheimo, 2004, Piscitelli *et al.*, 2005), *Pichia pastoris* (Jonsson *et al.*, 1997, Soden *et al.*, 2002, Colao *et al.*, 2006), *Kluyveromyces lactis* (Piscitelli *et al.*, 2005). The filamentous fungi are generally good hosts for protein secretion and good hosts for protein secretion. Several fungal laccase genes have been cloned and heterologously expressed in the filamentous fungi, such as *Aspergillus niger* (Record *et al.*, 2002), *Aspergillus oryzae* (Yaver *et al.*, 1996) and *Trichoderma reesei* (Bailey *et al.*, 2007).

1.6 Laccase Production at Bioreactor Scale by White Rot Fungi

In the literature, white-rot fungi are shown to produce higher level of laccase activity compared to those heterologously expressed in yeasts or filamentous fungi. They are also the only microorganisms able to mineralise all the components of lignin to carbon dioxide and water. However, one of the factors that limit wide application of fungal laccases is the lack of an efficient production system at bioreactor scale.

There are two main types of fungal culture systems, solid-state and submerged. In the industry, fermentation usually implies submerged liquid cultivation systems. Fermentation is a complicated multi-phase, multi-component process. Growth and production are affected by various parameters, including cultivation medium, inoculum type and concentration, pH, temperature, aeration, agitation, shear stress, etc. Compared to many unicellular microbes, filamentous culture presents special challenges in the optimisation and scale-up because of the varying morphological forms (Wang *et al.*, 2005).

Fungi morphology has a distinct effect on the rheology of a fermentation broth and thus influences the performance of a bioreactor. The effects of broth rheology on mass, momentum, and heat transfer within a bioreactor have been studied extensively. In submerged filamentous fungi fermentation, there are two extreme

types of morphology, pellets and free filaments (also called dispersed hyphae). Apart from these two types, an intermediate aggregated (but still dispersed) morphology exists which is termed as loose clumps.

Different morphology might be required for maximal production of a target product by different fungi. For example, free mycelia are preferred for the production of penicillin from *P. chrysogenum*, whereas pellets are preferred for the production of citric acid from *A. niger* (Vecht-Lifshitz *et al.*, 1990). Cultures with pelleted growth usually exhibit low apparent viscosity and near Newtonian rheology. The fermentation broth is often presumed to be well-mixed and the problems of poor gas-liquid mass transfer and bulk mixing are considered to be slight in smaller, lab scale fermenters. However, the centres of large pellets can suffer from oxygen starvation due to mass transfer limitation, resulting in autolysis. A 'radical radius' for pellets exists for sufficient mass transfer (Kobayashi *et al.*, 1973, Metz and Kossen, 1977). On the other hand, cultures with filamentous growth usually exhibit a high apparent viscosity and non-newtonian rheology. At moderate to high biomass concentrations, these broths usually display 'shear-thinning or pseudoplasticity', which could result in poor mixing and decreased overall productivity (Harvey and McNeil, 1994).

In the last few years different fermentation techniques and strategies have been applied to produce laccase at bioreactor scale by wild-type strains of filamentous fungi (Table 1.4). Submerged fermentation (SmF) involves the growth of microorganisms in a liquid medium often rich in nutrients and with high oxygen concentration (aerobic conditions). SmF includes free cell system and immobilised cell culture. The industrial production of enzymes is mainly performed by SmF. Solid-state fermentation is defined as any fermentation process occurring in the absence of, or in almost absent, free liquid; employing an inert substance (synthetic materials) or a natural substrate (organic materials) as a solid support.

Table 1.4: Different bioreactor scales for production of laccases by filamentous fungi

Fungus	Type of reactor	Type of cultivation	Inducer	Reference
	Stirred tank reactor (STR)	Submerged fermentation (SmF)		
<i>Corioloopsis gallica</i>	14 litre STR (8 litre)	SmF (pellets)	-	(Vandertol-Vanier <i>et al.</i> , 2002)
<i>P. tigrinus</i>	3 litre STR (250 rpm)	SmF, free cells	olive mill wastewater	(Fenice <i>et al.</i> , 2003)
<i>P. ostreatus</i>	3 litre STR (200 rpm)	SmF, free cells	olive mill wastewater	(Aggelis <i>et al.</i> , 2003)
<i>T. pubescens</i>	20 litre STR (150 rpm)	SmF, free cells	2 mM Cu ²⁺	(Galhaup and Haltrich, 2001)
<i>T. versicolor</i>	1 litre STR	SmF	30 µm xyldine	(Tavares <i>et al.</i> , 2006)
<i>T. versicolor</i>	5 litre STR (1.25 litre)	SmF (pellets)		(Thiruchelvam and Ramsay, 2007)
	Immobilised system			
<i>P. cinnabarinus</i>	10 litre packed-bed	SmF, immobilised on nylon cubes	10 mM veratryl alcohol	(Schliephake <i>et al.</i> , 2000)
<i>T. hirsuta</i>	1 litre fixed-bed	SmF, immobilised on stainless steel sponge	Cu ²⁺	(Rodriguez Couto <i>et al.</i> , 2004)
	Air lift reactor (ALR)			
<i>P. tigrinus</i>	3 litre ALR (2.5 L)	SmF, free cells	olive mill wastewater	(Fenice <i>et al.</i> , 2003)
<i>T. hirsuta</i>	2 litre ALR	SmF, immobilised in alginate beads	4 mM veratryl alcohol	(Dominguez <i>et al.</i> , 2005)
<i>T. versicolor</i>	2 litre ALR	SmF, free cells	Tween-80	(Rancano <i>et al.</i> , 2003)
<i>T. hirsuta</i>	6 litre ALR	SmF, free cells	Cu ²⁺ , glycerol	(Rodriguez Couto <i>et al.</i> , 2006)
		Solid state fermentation (SSF)		
<i>T. hirsuta</i>	1.8 litre tray (200ml)	SSF(orange peels)	5 mM Cu ²⁺	(Rosales <i>et al.</i> , 2007)
<i>T. versicolor</i>	1 litre tray	SSF (nylon sponge)	Tween-80	(Couto <i>et al.</i> , 2003)
<i>T. versicolor</i>	1 litre tray	SSF (barley bran)	Tween-80	(Couto <i>et al.</i> , 2003)

Due to the disadvantages of filamentous growth of white rot fungi, different strategies have been used to control fungal growth. Vandertol –Vanier *et al* (Vandertol-Vanier *et al.*, 2002) employed two-phase inoculation process to inoculate a 14 litre stirred tank for laccase production by *C. gallica*. The fungus was grown in shaken flasks for 3 days and then homogenised. A 5% homogenised inoculum was used to inoculate the production medium, which consisted of 3% (w/v) ground cereal flakes. After 9 days growth in submerged cultures at 27 °C, the pelleted fungus produced 15,000 U/l. Similar inoculation method was also applied in ligninolytic enzyme production by *T. versicolor* strain IJFM A137 in 1.5 litre agitated tank bioreactors and a fungal biomass grown in the form of pellets was achieved (Manzanares *et al.*, 1995).

Other authors immobilised fungi on/in different materials, such as nylon, stainless steel sponge and alginate beads, to control their growth rates. Microbial cell immobilisation refers to the systems or techniques that limit the migration of fungi. There is a physical confinement or localization of microorganisms that permits their economic reuse. Immobilised fungal cells have several advantages over dispersed cells. Immobilised cell systems make repeated batch culture possible and simplify both the continuous production and the subsequent downstream processes. Cell immobilisation also reduces significantly the apparent broth viscosity, therefore, makes the rheological features more favourable for oxygen supply and mass transfer (Thongchul and Yang, 2003). Moreover, cells are protected from shear damage by immobilisation, giving higher cell loading and higher volumetric productivities (Vassilev and Vassileva, 1992). Another advantage of cell immobilisation is the inhibition of protease activities. When compared to the suspension culture of *A. niger* (ATCC 13496), the method of cell immobilisation was found to greatly reduce the protease activity (Liu *et al.*, 1998). Several natural and synthetic materials (such as straw, jute, hemp, maple woodchips, and nylon and polyethylene terephthalate fibers) were used to immobilise *T. versicolor* ATCC 20869 and its ability to decolourise amaranth was evaluated (Shin *et al.*, 2002). Some white rot fungi were also encapsulated in a matrix such as alginate (Dominguez *et al.*, 2005, Park *et al.*, 2006). However, immobilisation by encapsulation is too complex, whereas surface

immobilisation on an inexpensive material such as woodchip is more economical.

Laccase productions by *P. tigrinus* have been performed and compared both in STR and ALR. The studies showed that laccase activity was strongly affected by the impeller speed (Fenice *et al.*, 2003). The effect of agitation on the enzyme production was studied by varying the impeller speed in 3 litre bioreactors at 250, 500 and 750 rpm respectively.

The laccase activity achieved at 250 rpm was higher compared to the other two conditions. Hess *et al.* also demonstrated that laccase production by *T. multicolour* decreased considerably when the fungus was grown in a STR, presumably because of the damage to the mycelia caused by shear stress (Hess *et al.*, 2002). Ryan *et al.* (Ryan *et al.*, 2005) developed an air lift loop reactor for laccase production by *T. pubescens*. The addition of a phenolic effluent resulted in higher laccase activity in the bioreactor compared to the one without induction. The suitability of the ALR for *T. pubescens* fermentation exhibited high rate of growth, high laccase production and it also established its potential to provide a practical, cost-effective bioremediation process for the treatment of phenolic wastewaters. Couto and co-workers found that the configuration of an air lift reactor was very suitable for the production of laccase from the white rot fungus *T. hirsute* (Rodriguez Couto *et al.*, 2006). Air lift reactor was also used for olive mill wastewater (OMW) remediation (Olivieri *et al.*, 2006). Olivieri *et al.* (2006) reported that ALR was fully capable of OMW remediation by the extracellular laccase secreted by the white rot fungus *P. ostreatus*. This is possibly due to low shear environment for laccase production (Bonnarme and Jeffries, 1990). ALR systems are simple, reliable and of low cost (Kiese *et al.*, 1980).

In recent years, solid state fermentation (SSF) has received more attention. Compared to submerged cultures, SSF appears to result in high yields with simpler downstream process operation, reduced energy requirement and low wastewater output. SSF

processes have shown to be particularly suitable for the production of enzymes by filamentous fungi (Moo-Young *et al.*, 1983) because they represent the conditions where these fungi grow in nature. The use of natural solid substrates, especially lignocellulosic materials as growth substrates for fungi has been studied for laccase production (Couto *et al.*, 2003, Rosales *et al.*, 2007). Lignocellulosic materials comprise a broad range of wastes from agricultural, food and forest industry, which not only provide some of the necessary nutrients required by those fungi but also can stimulate laccase production. Agriculture residues contain lignin or/and cellulose and hemicellulose, which act as inducers of laccase. Therefore, the employment of lignocellulosic materials in SSF results in considerable reduction in laccase production costs, therefore the whole process become more economical.

1.7 Statistical Approach

Traditional methods of optimization involve changing one independent variable while keeping the other variables fixed at certain levels. This one dimensional approach is laborious, time consuming, expensive and most importantly, incapable of providing the optimal conditions due to the lack of the interactions between different variables (Furuhashi and Takagi, 1984).

Statistical experimental designs have been widely used for several decades (Plackett and Burman, 1946, Box and Hunter, 1957). Contour surfaces, central composite, Plackett-Burman and response surface technology (RSM) are examples of statistical experiments designs that increase efficiency, improve products and decrease costs, therefore, they have received increasing attention. Statistical experimental designs can be applied at different aspects in process optimisation. The Plackett-Burman is very useful for the screening of the most important factors from a lot of candidates (Plackett and Burman, 1946). This design does not consider the interaction effects between variables but the most important factors affecting the results. RSM is a

factorial experiment design for examining the effect of test variables on measured responses. The RSM approach firstly requires an experimental design followed by fitting experimental data into an empirical model equation to determine the optimum conditions. With the development of gene engineering, biomaterials and other bioprocess technologies like biodegradation and bioremediation, more scientists are getting interested in adopting statistical experiment design to improve their biological processes and production by shortening time and increasing efficiencies (Lee and Gilmore, 2005).

Reducing the costs of enzyme production by optimising the fermentation medium is an essential aspect of basic research for industrial applications. Different statistical designs for medium optimization has been recently employed for lysozyme, xylanase, amylase and laccase production by fungal cultures (Thayer *et al.*, 1987, Dey *et al.*, 2001, Francis *et al.*, 2003, Lee *et al.*, 2003, Parra *et al.*, 2005, Parra *et al.*, 2005, Teerapatsakul *et al.*, 2007).

Parra and co-workers used an orthogonal design to optimise 13 medium components to enhance squalestatin production (Parra *et al.*, 2005). Castro and co-workers used a Plackett-Burman design to screen 20 different serum-free medium components to identify those important for CHO cell growth and recombinant human interferon (IFN)-gamma production (Castro *et al.*, 1992). The optimal medium composition of xylanase production by *Aspergillus terreus* was developed by Plackett-Burman design (Ghanem *et al.*, 2000). The effects of medium components, including glucose, asparagine, Tween-80, VA, Cu^{2+} , Mn^{2+} and pH on laccase, manganese peroxidase and glyoxal oxidase production by *T. troglia* have been studied using Plackett-Burman experimental design (Levin *et al.*, 2005).

The Orthogonal and Plackett–Burman designs are important methodologies that can reduce the number of runs to an absolute minimum. The principal objectives of these

designs are to screen main factors for further optimization processes from a large number of process variables (Castro *et al.*, 1992, Parra *et al.*, 2005). This enables a better picture of the possible effects of each component in the medium. However, the main disadvantage of these designs is that they consider only first order effects and ignore the interactions between variables. On the other hand, a full factorial design provides almost every possible combination, but it requires a large number of experiments, which is impractical to perform. Optimum performance has been determined using mathematical tools such as multiple regression of a partial or full factorial design to obtain a model of the production system, usually involving fitting of data to a polynomial equation, often using stepwise multiple regression. RSM has also been used to investigate the optimal regions of production of useful products (Prapulla *et al.*, 1992).

RSM, firstly described by Box and Wilson (Box and Wilson, 1951), is a collection of mathematical and statistical techniques (Myers *et al.*, 2002), which is not only used to evaluate the relationship between a set of experimental factors and observed results but also to seek the optimum conditions for multivariable system. RSM has been established as a convenient method for developing optimal conditions for processes with reduced cost and efficient screening of parameters (Vohra and Satyanarayana, 2002). The models from RSM take into account the interactions of variables in generating a process response effectively. In many processes, the relationship between the response and the independent variables is usually unknown; therefore, the first step in RSM is to evaluate the function (response) in terms of analysing variables (independent variables). Usually, this process employs a low-order polynomial equation in a pre-determined region of the independent variables, which is later analysed to locate the optimum values of independent variables for the best response. RSM has been successfully employed for many bioprocesses, particularly in optimisation of medium ingredients and operating parameters.

Thayer *et al.* (1987) and Oh *et al.* (1995) used response surface designs for rapid to optimisation of media and process conditions. Thayer and co-workers investigated the interactions of pH, temperature, air (aerobic versus anaerobic) and NaCl on the growth of *Salmonella typhimurium* ATCC 14028. RSM was used to develop equations that described the response of *S. typhimurium* to environmental changes (Thayer *et al.*, 1987). The method was applied to find optimum conditions of tryptone, yeast extract, glucose, Tween-80 and incubation temperature for the growth of *Lactobacillus casei* YIT 9018 and to evaluate the effects of these factors employing RSM (Oh *et al.*, 1995). RSM was also attempted to maximise lipid production by *Rhodotorula gracilis* (Prapulla *et al.*, 1992).

The growth medium for *P. tigrinus* laccase production was studied through RSM. The impact of five crucial variables on laccase production, including glucose and nitrogen concentrations and three putative inducers, copper sulphate, 2,5-xylidine and olive-mill wastewater was investigated thoroughly (Quarantino *et al.*, 2008). A Box-Wilson central composite design was applied to optimise copper, veratryl alcohol and L-asparagine concentration for ligninolytic enzyme production in submerged fermentation of *T. trogii* (Trupkin *et al.*, 2003). A seven-level Box-Behnken factorial design was employed to optimise the culture medium composition of *Ganoderma* sp. KU-Alk4 for improved laccase production (Teerapatsakul *et al.*, 2007). Box-Behnken experiment design was also applied in biodegradation of the reactive dye (Verofix red) by *P. chrysosporium*. Three variables, including dye concentration, days, nitrogen concentration, at three levels were studied to identify the correlation between those variables on biodegradation level (Nagarajan, 1999).

The application of RSM requires the use of models which effectively describe the response quantitatively. The models generally are multinomial in nature, and the most adequate degree for each factor and interaction can be chosen in the final form of relationship obtained. This technique finds most utility in optimisation of different processes to get the best performance under given constraints.

CHAPTER 2: MATERIALS AND METHODS

2.1 Strains

Corioloopsis polyzona (MUCL 38443) and *Pycnoporus sanguineus* (MUCL 41582) were obtained from the BCCM/MUCL (Belgian Coordinated Collections of Microorganisms/Mycothèque de l'Université Catholique de Louvain). *Pleurotus ostreatus* (ATCC no. MYA-2306) was obtained from Dipartimento di Chimica Organica e Biologica, Università di Napoli Federico II, Naples, Italy.

2.2 Materials

2.2.1 Media and Reagents

All chemicals used as growth media components and buffers were commercially available products from Sigma-Aldrich (Dorset, UK) and VWR (Leicester, UK) unless stated otherwise.

2.2.2 Strains Maintenance

2.2.2.1 *Maintenance Medium for P. ostreatus*

The *P. ostreatus* master culture was maintained at 4°C and routinely sub-cultured every one or two weeks on potato dextrose agar (PDA) plates, containing 24 g/l potato dextrose (Difco, MI, USA), 5 g/l yeast extract (Difco), 15 g/l agar (Difco). The medium was prepared in 1 litre of distilled water and autoclaved at 121°C for 15 minutes. One plug (10 mm diameter) of *P. ostreatus* mycelium was transferred and placed in the middle of the plate. This plate was incubated at 28°C in the dark for five to seven days until the fungal growth reached the edge of the plate, and then stored at 4°C.

2.2.2.2 *Maintenance Medium for P. sanguineus*

The *P. sanguineus* master culture was maintained at 4 °C and sub-cultured weekly on malt extract agar plates containing 20 g/l malt extract (Difco, MI, USA) and 15 g/l technical agar (Oxiode). The medium was prepared in 1 litre of distilled water and autoclaved at 121°C for 15 minutes. One plug (10 mm diameter) of *P. sanguineus* mycelium was transferred from a plate and placed in the middle of another plate. This plate was incubated at 28°C in the dark for five to seven days until the fungal growth reached the edge of the plate, and then stored at 4°C.

2.2.2.3 *Maintenance Medium for C. polyzona*

The *C. polyzona* master culture was maintained on wood chips at -80°C. These wood chips (approximately: 2cm (L) x 0.2 cm (W) x 0.1cm (D)) were autoclaved twice for 15 minutes and then arranged on the PDA plates (39 g/l) (Merck, Darmstadt, Germany). A colonised woodchip from the -80°C stock was inoculated in the middle of the plate. Within 6 days of incubation at 28°C, the wood chips were colonised by the fungus. They were then collected and stocked in cryogenic tubes at -80°C.

2.2.3 Production Medium for Laccase Production

2.2.3.1 *Medium Design and Composition*

The compositions of 11 different production media for the three strains are given in Table 2.1. The initial pH of each medium was adjusted before autoclaving and maintained using 0.1 M sodium tartrate buffer.

Table 2.1: Experimental design combinations for production media

Run	Potato dextrose broth (g/l)	Cu (mg/l)	Yeast extract (g/l)	MO ($\mu\text{g/l}$)	Buffer (pH)	Lactose (g/l)	Glucose (g/l)
1	25	18.7	1	0	4.0	15	7
2	25	56.2	1	150	4.0	0	0
3	5	18.7	5	150	4.0	0	7
4	5	56.2	5	0	4.0	15	0
5	15	37.5	3	75	4.5	10	5
6	15	37.5	3	75	4.5	10	5
7	15	37.5	3	75	4.5	10	5
8	5	18.7	1	150	5.0	15	0
9	5	56.2	1	0	5.0	0	7
10	25	18.7	5	0	5.0	0	0

2.2.3.2 Mannan Oligosaccharides Preparation

Mannan oligosaccharides (MO) (Figure. 2.1) were obtained from locust bean gum (LBG) through enzymatic hydrolysis. The polysaccharide (1.0 g) was dissolved in 50 ml HPLC water and further dissolved by heating. The mixture was incubated at 80 °C for 5 minutes after the addition of Gammanase® (Novozyme, Denmark) (100 μl). Subsequent heating at 100 °C denatured the enzyme and stopped the reaction producing MO with a degree of polymerisation (DP) range of 5-8.

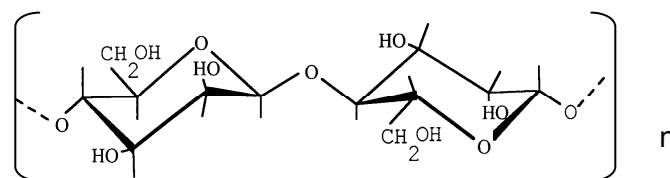
**Figure 2.1:** Schematic diagram of mannan oligosaccharides (MO)

2.2.3.3 Addition of Ferulic Acid and MO

Different combinations of MO and ferulic acid were prepared based on a central

composite experiment design. The MO and ferulic acid were added to shaken flask cultures at 24 and 72 hours respectively. The factors and levels are coded as positive (+1), zero (0) and negative (-1) for the higher, middle and lower concentrations used in the experiments (Table 2.2).

Table 2.2: Concentrations and levels for different combination of factors to be investigated.

Factor	Levels		
	-1	0	+1
MO (mg/l)	0	75.0	150.0
Ferulic acid (mM)	0	0.5	1.0

2.2.4 Medium for laccase production by *C. polyzona*

Composition of the production medium (SM) for production of laccases by *C. polyzona* is shown in Table 2.3.

The medium was autoclaved at 121°C for 15 minutes except for Thiamin-HCl, which was added into flasks before inoculation by filter sterilisation using a 0.2 µm cellulose acetate membrane filter (Orange Scientific). In order to induce laccase production, filter-sterilised ferulic acid was added to 3-day-old cultures to a final concentration of 1mM.

Table 2.3: Composition and concentration for laccase production medium of *C. polyzona*

Standard Medium (SM) Composition	Concentration (g/l)
Glucose	50.00
Bactopeptone (Lab M, Bury, UK)	17.00
KH ₂ PO ₄	2.50
MgSO ₄	0.50
CuSO ₄ · 5H ₂ O	0.02
MnSO ₄	0.05
Thiamin-HCl (Vitamin B1 Hydrochloride)	0.01

2.2.4.1 Varying Glucose Concentration

Different glucose concentrations were applied to the production medium in the shaken flask cultures. The final concentrations of carbon source in the media were 10 g/l, 20 g/l, 30 g/l, 40 g/l and 50 g/l glucose. The rest of the ingredients were remained the same as SM. The media were sterilised by autoclaving at 121°C for 15 minutes. Filter-sterilized ferulic acid was added to 3-day-old cultures to a final concentration of 1 mM.

2.2.4.2 Addition of Wood Powder

The control medium refers to the treatment with SM. Oak wood powder (1 %, w/v) was added to the shaken flask and STR cultures before autoclaving. Inducer ferulic acid was filtered through 0.2 µm filter and added to 3-day-old cultures, giving the final concentration of 1 mM.

2.2.5 Fermenter Parameters

2.2.5.1 *Stirred Tank Reactor (2 litre)*

Laccase production by *C. polyzona* was carried out in a 2 litre stirred tank reactor with working volume of 1.8 litre. The 2 litre bioreactor (Electrolab) was equipped with instrumentation for measurement and control of agitation, temperature, pH and dissolved oxygen tension (% DOT). The agitator was equipped with two standard Rushton turbine impellers, each of which had six flat blades. Temperature, pH and % DOT were monitored throughout the fermentation. A carbon dioxide and oxygen analysis system was used to monitor the composition of the outlet gas.

2.2.5.2 *Stirred Tank Reactor (5 litre)*

Scale up to 5 litre stirred tank reactors (with 3.5 litre working volume) for the production of laccases by *C. polyzona* was performed. The 5 litre bioreactor (Electrolab) was equipped with two Rushton turbine impellers, each of which consisted of six flat blades. The temperature, pH and % DOT were monitored throughout the fermentation.

2.2.5.3 *Stirred Tank Bioreactor (20 litre)*

Production of laccase by *C. polyzona* was further scaled up to 20 litre stirred tank bioreactor with a working volume of 14 litres. The agitator was the combination of two Rushton turbines and a variable pitch impeller (45°). The design of 20 litre bioreactor is shown in Figure 2.2 with the dimension and location of the impellers.

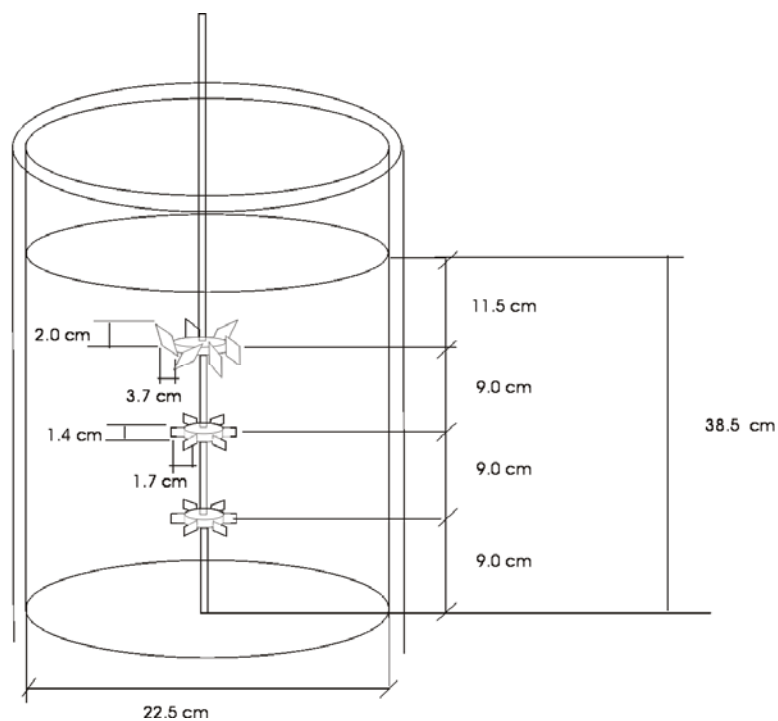

Figure 2.2: The configuration of 20 litre stirred tank reactor

The stirrer speed, % DOT and pH were monitored online throughout the fermentation. Sterilisation-in-Place (SIP) process was carried out on site.

2.2.5.4 *Stirred Tank Reactor (150 litre)*

The fermentation of *C. polyzona* was subsequently scaled up to 150 litre pilot scale stirred tank reactor. The pilot scale fermentation was carried out at Wetlands Engineering, Belgium. The fermentation system as shown in Figure 2.3 comprised of two bioreactors at 50 and 150 litre volumes, where the 50 litre tank was used as a sterile medium feed reservoir for fed-batch fermentation.



Figure 2.3: (A) The pilot scale fermenter system (Wetlands Engineering, Belgium) (B) 50 litre bioreactor (C) 150 litre bioreactor.

The 50 litre stirred tank was used as a reservoir for mixing of the fresh medium, its sterilisation and subsequent storage after sterilisation. The 150 litre stirred tank bioreactor with a working volume of 100 litre was employed. The fermenter was equipped with three Rushton turbines and instrumentation for measurement and control of stirrer speed, temperature, pH and %DOT. These parameters were monitored throughout the fermentation. Sterilisation in Place (SIP) process was performed on site. The sample line was sterilised for 15 minutes and cooled to the room temperature before sampling.

2.2.6 Dyes and Reagents

2.2.6.1 *Single Dyes*

The composition of a model wastewater containing single dye is shown in Table 2.4. The structures of selected single dyes tested in the present work are depicted in Figure 2.4. All the dyes were a gift from Dr. Sophie Vanhulle from Universite Catholique de Louvain.

Table 2.4: Composition of model wastewater containing single dye.

Dye type	Name	λ_{\max}	Dye concentration (g/l)	Salt (g/l)	pH
Anthraquinone dye	Acid Blue 62	620	0.1	Na ₂ SO ₄ (2)	5 (with acetic acid)
Azo dye	Acid Black 194	575	0.1	Na ₂ SO ₄ (2)	5 (acetic acid)
Disazo dye	Reactive Black	590	0.125	Na ₂ SO ₄ (70)	10 (acetic acid and NaOH)
Azo dye	Direct Blue 71	575	0.1	NaCl (5)	9 (Na ₂ CO ₃)

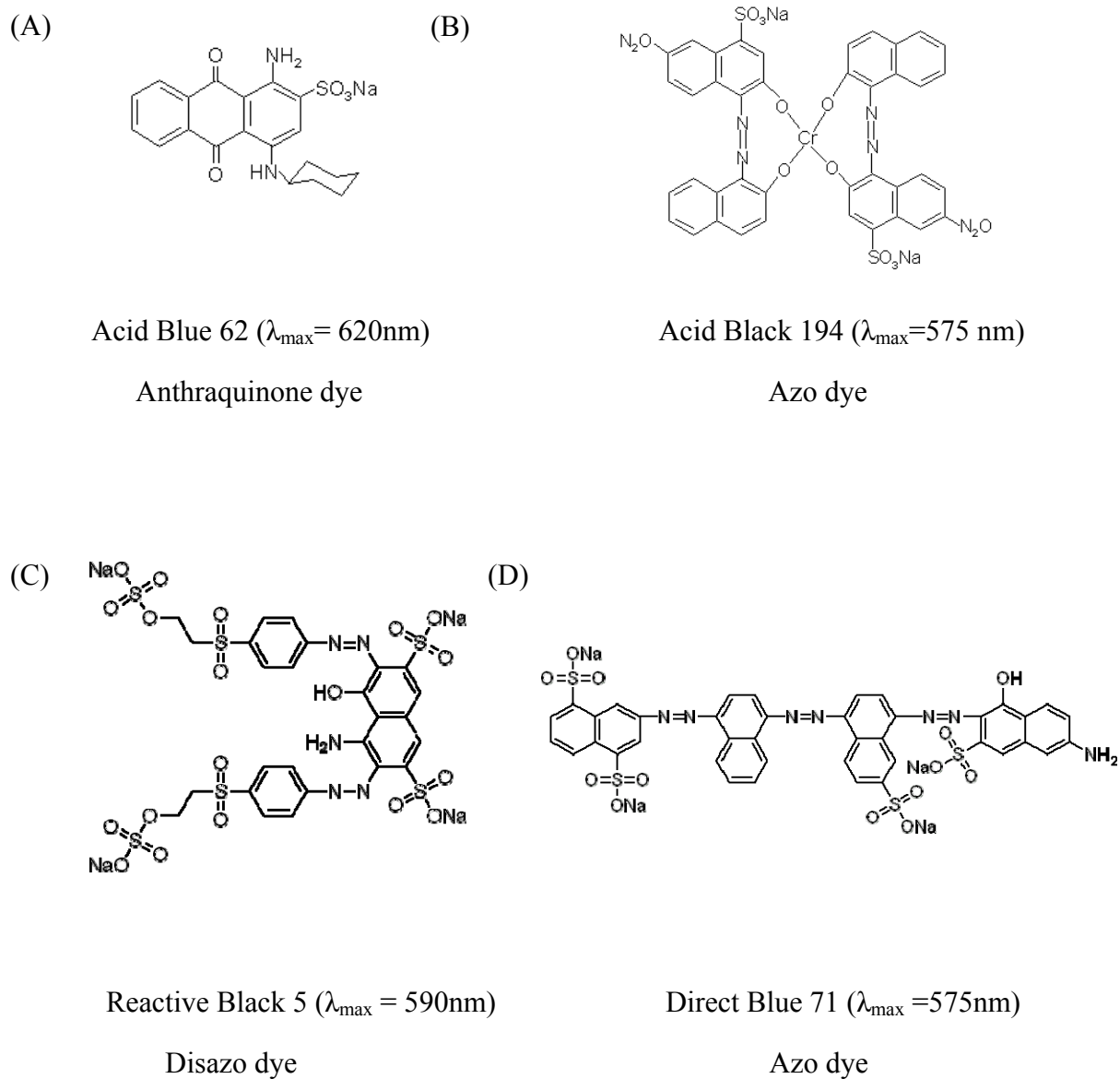

Figure 2.4: Structure and chemical class of textile dyes used.

2.2.6.2 Mixed Dyes

Table 2.5 summarises the compositions of four mixed dye solution employed in the study, each of which contains three single dyes and a type of salt. All the dyes were a gift from Dr. Sophie Vanhulle from Universite Catholique de Louvain.

Table 2.5: Composition of the four investigated model wastewater preparations containing mixed dyes.

Dyes type	Name	λ_{\max}	Dye concentration (g/l)	Salt	pH
Acid dye bath for wool	Acid Blue 62 (Abu62)	600	0.100	Na ₂ SO ₄ (2 g/l)	5.0 (with acetic acid)
	Acid Yellow 49 (AY49)	435	0.100		
	Acid Red 266 (AR 266)	480	0.100		
Acid dye bath for leather	Acid Black 210 (ABk 210)	465/600	0.100	Na ₂ SO ₄ (2 g/l)	5.0 (with acetic acid)
	Acid Black 194 (ABk 194)	575	0.100		
	Acid Yellow 194 (AY 194)	450	0.100		
Reactive dye bath for cotton	Reactive Blue 222 (RBU222)	615	0.125	Na ₂ SO ₄ (70 g/l)	10.0 (with acetic acid and NaOH)
	Reactive Red 195 (RR 195)	545	0.125		
	Reactive Yellow 145 (RY 145)	420	0.125		
	Reactive Black 5 (RBk 5)	600	0.125		
Direct dye bath for cotton	Direct Blue 71 (DrBu 71)	575	0.100	NaCl (5 g/l)	9.0 (with NaCO ₃)
	Direct Red 80 (DrR 80)	550	0.100		
	Direct Yellow 106 (DrY 106)	420	0.100		

2.2.6.3 *Mediators*

Mediators ABTS and violuric acid (VA) used in dye decolourisation were purchased from Sigma-Aldrich.

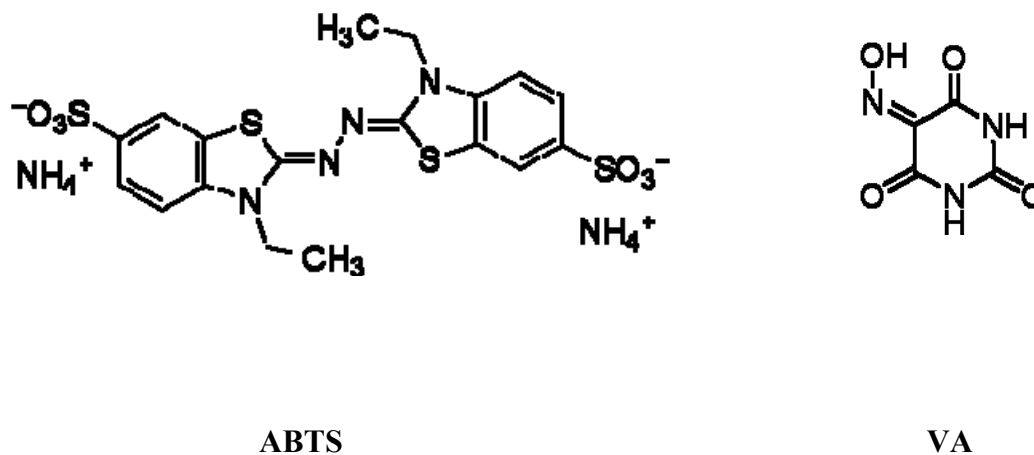

Figure 2.5: Structure of ABTS and VA

2.2.7 Reagents & Equipment

All the substrates and buffers for laccase assay were purchased from Sigma-Aldrich (Dorset, UK) and VWR (Leicester, UK). The Perkin Elmer Lambda 35 UV/Vis spectrometer was used for the assay. Dye decolourisation experiments were performed by employing FLUOstar OPTIMA (BMG LABTECH) as 96-well plate reader.

2.3 Methods

2.3.1 Response Surface Technology in Medium Optimization for the Three Strains

2.3.1.1 *Experimental Design and Statistical Analysis in Medium Optimization for Three Strains*

Elicitor MO and ferulic acid addition to the cultures were investigated to determine their best combination to enhance laccase production by three basidiomycetes strains. The optimization was based on a central composite experimental design 3^2 . Table 2.6 shows the factor codes and natural values used in this experiment. The factors are arranged into three levels and coded -1, 0 and +1 for low, middle and high concentration (value) respectively. For prediction of optimal point, a second- order polynomial function was fitted to correlate the relationship between variables and response (laccase activity).

Table 2.6: Factors and levels used for the central composite design.

Key	Variable	Levels		
		Low (-1)	Medium (0)	High (+1)
X ₁	MO (mg/l)	0	75.0	150.0
X ₂	Ferulic acid (mM)	0	0.5	1.0

2.3.1.2 *Statistical Analysis*

For the purpose of studying the effect of the MO and ferulic acid on the production of laccases, a central composite design was used for each strain, giving the indication of the interaction effects of the factors under investigation.

A mathematic model describing the relationships between laccases produced and the medium component in a second-order equation was developed. The laccase activity produced by the three strains of basidiomycetes was multiple regressed with respect to MO and ferulic acid concentrations by the least squares method as follows:

$$Y = A_0 + \sum A_i X_i + \sum A_{ii} X_i^2 + \sum A_{ij} X_i X_j$$

where Y is the predicted response variable (laccases produced), A_0 , A_i , A_{ii} , A_{ij} are constant regression coefficient of the model, and X_i , X_j ($i=1$ and 2 ; $j=1$ and 2). The coefficients represent the variables independence (medium composition) in the form of coded values. The accuracy and general ability of the above polynomial model could be evaluated by the determination of R^2 . All experimental designs were randomised to exclude any bias. The analysis of regression and variance (ANOVA) was carried out using the experimental design Statistica 7.0 (StatSoft Inc., USA).

2.3.2 Inoculation and Culture Condition

2.3.2.1 *Inoculation and Culture Conditions of the Three Strains for Laccase Production*

a) *Shaken Flask Studies*

Plug inoculation was initially adopted in strains screening for *C. polyzona*, *P. ostreatus* and *P. sanguineus*. Twenty 1-mm plugs were cut from the edge of actively growing 8-day-old *C. polyzona*, *P. ostreatus* and *P. sanguineus* on PDA plates and aseptically transferred to 500 ml Erlenmeyer flasks containing 100 ml of production medium based on the experiment design (as shown in Table 2.1). The flasks were incubated at 28 °C on a rotary shaker at 150 rpm for up to 23 days. Samples were collected every 1 to 2 days and assayed for laccase activity.

2.3.2.2 *Inoculation and Culture Conditions of C. polyzona for Laccase Production*

a) *Shaken Flask Studies*

Conidia inoculation was employed in laccase production by *C. polyzona*. The conidia suspension of *C. polyzona* was prepared using the following procedures. A colonised woodchip from -80°C stock of *C. polyzona* was inoculated in the middle of PDA plate. After 6 days incubation at 28°C, conidia were harvested using Tween-80 solution (0.05% v/v). One ml of the conidia suspension was used to inoculate 500 ml Erlenmeyer flasks containing 100 ml production medium (as described in section 2.2.1). The final concentration of conidia in the shaken flasks was 2.6×10^7 per ml. The shaken flasks were incubated in a rotary shaker at 28°C at a speed of 150 rpm. Samples were collected every 24 hours and assayed for laccase activity, glucose consumption and total protein concentration until laccase activity decreased.

2.3.2.3 *Bioreactor Studies (2 litre)*

Two bioreactors were used to run simultaneously with different inoculum preparations. A colonised woodchip from -80°C stock was inoculated in the middle of the PDA plate. After 6 days of incubation at 28°C, conidia were harvested from PDA plates using 20 ml Tween-80 solution (20 ml, 0.05% v/v) and mycological loop. Under aseptic condition, 20 ml of conidia suspension was used as inoculum to inoculate a 2 litre bioreactor containing 1.8 litre production medium for *C. polyzona* (as described in 2.2.4). The final concentration of conidia in the bioreactor at the starting point was 2.64×10^7 conidia per ml.

As inoculation of agar plugs into bioreactor cannot be applied easily, another set of fermentation was carried out using mycelium inoculation. A colonised woodchip from -80°C stock was inoculated in the middle of the plate. After 6 days incubation at 28°C, 15, 5-mm agar plugs were punched from the periphery of agar plates and inoculated into 500 ml flasks containing 100 ml production medium as described in

section 2.2.4. Cultures were incubated at 28°C on a rotary shaker (150 rpm). After 2 days, 200 ml of culture broth were transferred to the 2 litre bioreactor containing 1.6 litre production medium (as described in 2.2.4). In this case, ferulic acid was added to the 2 litre bioreactor on the third day after pre-inoculum was transferred into the fermenter. The final concentration of ferulic acid was 1 mM. In order to avoid foaming, one ml of silicon based antifoam (Sigma) was added into the production medium before sterilisation. Sterilisation of the two bioreactors containing the production medium was carried out at 121°C for 45 minutes. The stirrer speed was originally set at 150 rpm. Dissolved oxygen was maintained above 20% by increasing stirrer speed to 250 rpm during the course of fermentation. The airflow rate and temperature were kept at 1.0 vvm and 28°C respectively throughout the fermentations. The culture was assayed for laccase production, pH, glucose consumption and protein concentration over the period of 29 days. Total dry cell weight was determined at the end of fermentation.

A dynamic substrate feeding was applied to evaluate the effect of nitrogen, carbon and inducer on laccase production. The feed composition and its addition time are presented in Table 2.7.

Table 2.7: Feeding compositions and addition time during the fed-batch fermentation of *C. polyzona* in 2 litre bioreactor.

Feed composition	Day
ferulic acid 1mM	3
20 % SM (300ml)	14
ferulic acid 1mM	17
20 % SM (300ml)	24
ferulic acid 1mM	27

2.3.2.4 Bioreactor Studies (5 litre)

The inoculum was prepared from cryogenic woodchip stock culture (-80°C). One colonised woodchip from the stock was used to inoculate on a PDA slant in 300 ml medical bottles and incubated at 28°C. Conidia were harvested from actively growing cultures from PDA slants on day 6 with Tween-80 (100 ml, 0.05% v/v) aqueous solution and glass beads. The conidial suspension was used to inoculate two 5 litre fermenters containing 3.5 litre production medium (SM) to a final concentration of 2.6×10^5 conidia per ml in the medium. The antifoam (1.5 ml) was used to avoid foaming. The 5 litre stirred tank reactors were operated at 1.0 vvm and 28°C. The samples were taken every 24 hours for lacase production, pH and dry cell weight. The stirrer speed was increased gradually from initial 150 rpm to 450 rpm during the course of fermentation in order to maintain the dissolve oxygen above 20%.

A dynamic substrate feeding was applied on different physiological condition to evaluate the effect of nitrogen, carbon and inducer on laccase production. The fed-batch addition time and compositions are presented in Table 2.8.

Table 2.8: Feeding compositions and addition time during the fed-batch fermentation of *C. polyzona* in 5 litre bioreactor.

Label	Feed composition	Day
a	ferulic acid 1mM	3
b	10 % SM + 0.1 mM ferulic acid	14
c	ferulic acid 1mM	16
d	20 % SM + 40 mg/l CuSO ₄	20
e	20% SM-without bactopectone	29

2.3.2.5 Bioreactor Studies (20 litre)

Conidia inoculation was adopted in scale up experiments. Conidial suspensions were harvested from 7-9-day-old agar slants in 300 ml medical bottles and scraped off by using 2 mm sterilised glass beads in 100 ml 0.05% (v/v) Tween-80 solution. They were then collected and directly inoculated into the 20 litre bioreactor containing 14 litre production medium under aseptic conditions, resulting in the final inoculum of $\sim 1.0 \times 10^7$ conidia per ml in the production medium. The antifoam (3 ml) was added to the production medium before in situ sterilisation.

Stirrer speed and air flow rate were maintained at 150-500 rpm and 1.0-1.5 vvm respectively to ensure the DOT was above 20%. The temperature was maintained at 28°C throughout the course of fermentation. Other nutrients were added during the fermentation under aseptic conditions as described in Table 2.9.

Table 2.9: Feeding compositions and addition time during the fed-batch fermentation of *C. polyzona* in 20 litre bioreactor.

Label	Feed composition	Day
a	1mM ferulic acid	3
b	20% [SM]	6
c	20% [1mM ferulic acid]	9
d	20% [SM]	10
e	20% [1mM ferulic acid]	13
f	20% [SM]	15
g	20% [1mM ferulic acid]	18
h	20% [SM]	20
i	20% [1mM ferulic acid]	23

2.3.2.6 Bioreactor Studies (150 litre)

The fermentation of *C. polyzona* was subsequently scaled up to 150 litre stirred tank reactor. Antifoam, 22 ml and 9 ml, were added to 150 litre and 50 litre tanks respectively prior to *in situ* sterilisation. The 50 litre tank was used as a feed reservoir for the 150 litre fermenter. The 150 litre fermenter was equipped with three Rushton turbines and instrumentation for measurement and control of stirrer speed, temperature, pH and % DOT air saturation. The addition time and medium composition are presented in Table 2.10.

Table 2.10: Feeding compositions and addition time during the fed-batch fermentation of *C. polyzona* in 150 litre bioreactor.

Label	Feed composition	Day
a	1mM Ferulic acid	3
b	20% [SM]	7
c	20% [1mM Ferulic acid]	10

2.3.3 Assays

During fermentations, samples (1 ml) were periodically and aseptically collected from the culture broth. The fungal mycelia were removed from samples by centrifugation at 12,500 g at 4°C for 20 minutes. The supernatants were used for determination of laccase activities, protein concentration and glucose depletion. All the assays were carried out in triplicate.

2.3.3.1 *Laccase Assay*

Laccases are extracellular enzyme secreted in the medium. Laccase activity of the cell-free broth was determined using ABTS as substrate. The assay mixture contained 200 µl of 2.5 mM ABTS (dissolved in 100 mM sodium tartrate buffer pH 3), 950 µl of 100 mM sodium tartrate buffer at pH 3 and 50 µl of appropriately diluted culture supernatants. The product formation rate from enzymatic oxidation of ABTS was measured spectrophotometrically at 414nm with an extinction coefficient $\epsilon=3.6 \times 10^4 \text{ M}^{-1}\text{cm}^{-1}$. The unit activity of laccase was expressed as 1 µM of product formed per min. The enzymatic reactions were carried out at room temperature (22-25°C).

2.3.3.2 *Protein Assay*

Total extracellular protein concentration (mg/ml) was determined by the Folin-Lowry

method (Lowry *et al.*, 1951) with bovine serum albumin (1 mg/ml) as the standard. The assay solution consisted of:

Table 2.11: Protein assay solution

Assay solution	Concentration (g/l)	Volume (ml)
Copper sulphate	10	1
Sodium potassium tartrate	20	1
Sodium carbonate in 0.1M NaOH	20	100

One ml of the assay solution was added to 200 μ l of standards and samples. The mixture was left at room temperature for 10 minutes. 100 μ l of the $\frac{1}{2}$ strength Folin reagent was added to the mixture. It was left at room temperature for 25 minutes. Optical density was read at 750 nm.

2.3.3.3 *Glucose Assay*

Glucose concentration in the fermentation samples was determined by enzymatic colorimetric method using commercial kits (FLUITEST[®] GLU, Biocon[®] Diagnostik, Germany). The assay is based on Trinder reaction (Trinder, 1969).

2.3.3.4 *Biomass Assay*

The biomass concentration was determined by fungal mycelium dry cell weight. The mycelium was washed by filtration on filter paper (Whatman No.1) and dried overnight at 100 °C to a constant weight together with pre-weighed filter paper. The mycelium weight was calculated by subtracting the weight of pre-weighed filter paper. Growth yield was expressed as grams of mycelium dry weight per litre of culture.

2.3.4 Laccase Purification

The *C. polyzona* culture from 5 litre stirred tank reactor was harvested on the optimal day for laccase production day. The supernatant was separated from cells via centrifugation at 3,000×g for 30 minutes. Secreted proteins in the supernatant were then precipitated by the addition of (NH₄)₂ SO₄ up to 80 % saturation at 4 °C and centrifuged at 3,000×g for 30 min. The ammonium sulphate precipitate was resuspended in 50 mM sodium phosphate buffer pH 7.0 containing 1 M (NH₄)₂ SO₄. Sample of 20 ml was loaded onto a Phenyl Sepharose High Performance 35/100 column (Amersham Biosciences) equilibrated with 1M ammonium sulphate in 50 mM sodium phosphate buffer (pH 7.0). The enzyme was eluted with a linear gradient from 1 to 0 M (NH₄)₂ SO₄ in the 50 mM sodium phosphate buffer (pH 7.0) at a flow rate of 3 ml/min. Laccase-positive fractions were pooled, concentrated and desalted on an Amicon PM-10 (Millipore) membrane against 50 mM Tris-HCl, pH 8.0. After ultrafiltration (UF)/ diafiltration (DF), the sample was loaded onto a Mono-Q anion exchange column (Amersham Biosciences) equilibrated with 50 mM Tris-HCl, pH 8.0. After washing, laccases were eluted at a flow rate of 2 ml/min with a step gradient from 0 to 0.5 M NaCl. The step gradient was described as follows (expressed as percentages of buffer B): 0% 6 minute; 0-20% 6 minute; 20% 7 minute; 20%-100% 24 minute and 100% 3 minute. The active fractions were pooled, concentrated and desalted on an Amicon PM-10 (Millipore) against 50 mM sodium phosphate buffer, pH 7.0, then stored at -80°C. All the chromatography steps were carried out on ÄKTA Explorer system (Amersham Biosciences) at room temperature.

2.3.4.1 *Protein Assay*

The protein concentration was determined using Bradford reagent (Bio-Rad) with bovine serum albumin as a standard in the laccase purification and characterisation experiments.

2.3.5 Laccase Characterisation

2.3.5.1 *Electrophoresis*

Sodium dodecyl sulphate polyacrylamide gel electrophoresis (SDS-PAGE) on 12.5% polyacrylamide gel containing 0.1% SDS was performed following the method of Laemmli (Laemmli, 1970). Precision Plus Protein™ prestained standards (Bio-Rad) was used as marker of protein molecular weight with a volume of 10 µl. After treated with sample buffer (Laemmli buffer, Bio-Rad) and boiled at 100°C for 3 minutes, samples were denatured and loaded onto the gel. The gel was installed on a protean II proteomics gel electrophoresis apparatus (Bio-Rad). A voltage of 150 V was applied through a Bio-Rad power pack and the gels were left running for 45 minutes to achieve sufficient migration. Proteins were visualized by staining the gel with Coomassie blue G-250 (Sigma-Aldrich, USA) and the molecular weight of laccase isozymes was determined by comparing with molecular weight markers (Precision Plus Protein prestained standards, Biorad).

Native PAGE (non-denaturing PAGE) was carried out in alkaline pH condition, in which anionic detergent SDS was omitted from gels and the samples were not incubated prior to the loading of the gels. Separating and stacking gels were 9 and 4% acrylamide, respectively. Buffer solutions that applied in Native PAGE were 50 mM Tris-HCl, pH 7.5 for stacking gel; the running buffer was 25 mM Tris, 190 mM glycine, pH 8.4 (Palmieri *et al.*, 2003). Samples (12 µl) were loaded on the gel. The gels were stained with 0.4mM ABTS in 100 mM sodium tatrata buffer (pH 3.0) to visualize laccase activity.

2.3.5.2 *Isoelectric Point Determination*

The isoelectric point of the protein was determined using commercially available polyacrylamide gels (PhastGel IEF 3-9, GE Healthcare Life Sciences). The isoelectric focusing was performed on Phast-System (Pharmacia, Uppsala, Sweden) according to

the manufacture's instruction. After electrophoresis, bands containing laccase activity were visualised by staining the gel with 2.5 mM ABTS in 100 mM sodium tartrate buffer (pH 3.0).

2.3.5.3 *Size Exclusion Chromatography for Molecular Mass Studies*

Gel filtration was carried out with a pre-packed Superdex-200 (Superdex-200 10/300GL, GE Healthcare), which was equilibrated with 0.15 M Tris-HCl (pH 7.0) at a flow rate of 0.5 ml/min. Purified isoenzymes (100 μ l) were loaded on the column respectively. For molecular mass estimation, the column was calibrated with cytochrome C (12 kDa), carbonic anhydrase (29 kDa), bovine serum albumin (66 kDa), and apoferritin (443 kDa) as standards.

2.3.5.4 *In-situ Digestion*

Mass spectrometric analyses were performed on the Commois blue-stained proteins excised from a preparative SDS-PAGE electrophoresis on a 12.5% polyacrylamide gel. Excised bands were washed with acetonitrile and then with 0.1 M ammonium bicarbonate. To reduce any disulfide bridges in the protein, dithiothreitol was added to a concentration of 10 mM and the temperature was raised to 56°C for 45 minutes. After cooling to the room temperature, the samples were carboxamidomethylated by using 55 mM iodoacetamide in 0.1 M NH_4HCO_3 for 30 minutes. The samples were kept in the dark at room temperature. The gel particles were then washed with ammonium bicarbonate and acetonitrile. Finally, enzymatic digestions were carried out with 4 μ g trypsin in 50 mM ammonium bicarbonate, pH 8.5 at 4 °C for 4 hours. The buffer solution was then removed and a new aliquot of the enzyme/buffer solution was added for 18 hours at 37 °C. A minimum reaction volume that is sufficient for complete rehydration of the gel was used. Peptides were then extracted by washing the gel particles with 20 mM ammonium bicarbonate and 0.1% trifluoroacetic acid in 50% acetonitrile at room temperature and then lyophilised. Aliquots of the digests were directly analyzed by MALDI-MS.

2.3.5.5 *Mass Spectrometry Analysis*

Matrix-assisted laser adsorption ionization-mass spectrometry (MALDI-MS) analyses were performed using a Voyager DE Pro MALDI-TOF mass spectrometer (Applied Biosystems) in order to compare the laccase isozymes from *C. polyzona*. A mixture of analyte solution, α -ciano-4-hydroxy-cinnamic acid or sinapinic acid as matrices, bovine insulin and horse heart myoglobin as standards were applied to the sample plate and air-dried. Mass calibration was obtained using the quasi-molecular ions (MH^+) from horse myoglobin (16,952.50 m/z), bovine insulin (5734.59 m/z) and α -ciano-4-hydroxy-cinnamic acid (379.06 m/z) as internal standards. Raw data were analyzed by using computer software provided by the manufacturer and are reported as average masses or monoisotopic masses (Palmieri *et al.*, 2003).

2.3.5.6 *Enzyme Activity and Stability with respect of pH and Temperature*

The optimal pH for purified *C. polyzona* laccases was determined in glycine-HCl (pH 2.2-2.65), McIlvaine buffer (pH 2.8-7.0) using ABTS, DMP and syringaldazine as substrates. The effect of temperature on enzyme activity was determined by measuring the activity with ABTS within a temperature range of 20°C - 90°C in a temperature controlled spectrophotometer. The measurement was carried out in 100 mM sodium tartrate buffer at pH 3.0. The pH stability of Lac I was determined by incubating the enzyme solution (50 μ l) in various buffer systems, which are McIlvaine buffer (pH 3.0 and 5.0), sodium phosphate buffer (pH 6.0 and 7.0) and Tris-HCl (pH 8.0 and 9.0) at 25°C and 40°C. The residual laccase activity was determined using ABTS as substrate.

2.3.5.7 *Substrate Specificity and Inhibition Studies*

Nine compounds were tested as substrates for the *C. polyzona* laccases. This was qualitatively explored by changes in the optical absorbance spectra of the reaction mixtures which contained 400 μ M potential substrates, 50mU of purified isoenzymes and 100 mM sodium tartrate buffer pH 3.0. The effect of potential inhibitors on

laccase activity was determined using ABTS (2.5 mM) as substrate in sodium tartrate buffer (100 mM, pH 3.0) in the presence of various inhibitors.

2.3.6 Dye Decolourisation

2.3.6.1 *Decolourisation of Single Dyes*

Single dye decolourisation experiments were conducted in 96-well plates at room temperature. The purified laccase from *C. polyzona* was applied to single dye. The total assay volume was 200 μ l in 300- μ l wells. The reaction mixtures consisted of 160 μ l single model textile dye, 20 μ l of purified laccase (100 U/l) and 20 μ l mediators. Various mediators were applied, including ABTS, VA and Mn^{2+} , H_2O_2 .

2.3.6.2 *Decolourisation of mixed dyes*

Culture broth from shaken flasks was harvested on the optimal laccase production day when the highest laccase activity was achieved. Cells were removed by centrifugation at 12,000 g and 4°C for 15 minutes. Decolourisation of mixed dyes by purified laccase and filtered culture broth of *C. polyzona* was performed in 96-well plates at room temperature (25°C). The total assay volume was 200 μ l in 300- μ l wells. The reaction mixtures consisted of 160 μ l of mixed dyes, 20 μ l of sample with laccase activity of 100 U/l and selected mediators.

In order to investigate the effect of Mn^{2+} , H_2O_2 , ABTS and violuric acid (VA) on dye decolourisation of the mixed dyes (as described in Table 2.4) by filtered culture broth and purified laccase of *C. polyzona*, experiments were designed as follows:

- (a) As for purified laccase (Lac I) from *C. polyzona*, two levels of $MnSO_4$ and/or H_2O_2 were added to or omitted from the reaction mixture where appropriate. The reaction was monitored at 1 hour, 2 hours and 24 hours.

- (b) In the case of culture broth from *C. polyzona*, the laccase level was diluted to 100 U/l with HPLC water. Two levels of MnSO_4 and/or H_2O_2 were added to or omitted from the reaction mixture where appropriate. The reaction was monitored at 1 hour, 2 hours and 24 hours.
- (c) As for reactive and direct dye bath, culture broth from *C. polyzona* (laccase activity was diluted to 100 U/l), with or without the redox mediators ABTS and VA. Two concentrations of ABTS (0.25 mM and 2.5 mM) and VA (0.25mM and 2.5mM) were incubated together with the model dye wastewater solution for 1, 24 and 48 hours respectively.

2.3.6.3 Dye decolourisation rate determination

Mixed dye decolourisation was measured at three selected wavelengths: 410, 520 and 620 nm, where the specific changes in the colour of yellow, red and blue could be monitored respectively. The decolourisation percentage was determined by monitoring the decrease in the absorbance at 410, 520 and 620 nm for mixed dye, and at maximum wavelength for single dye with a UV-Vis spectrophotometer and calculated according to the following equation:

$$\text{Percentage of decolourisation (\%)} = \frac{A_b - A_a}{A_b} \times 100$$

where A_a is the absorbance at the maximum adsorption wavelength of the dye after decolourisation and A_b is the absorbance at the maximum adsorption wavelength before decolourisation.

2.3.6.4 Optimization of reactive black 5 (RB5) decolourisation by response surface methodology

Three experimental factors, pH, purified laccase and laccase mediator VA, were designated as X_1 , X_2 , X_3 respectively and varied at three levels. These three parameters were considered as significant variables in dye degradation, ranges of which were based on results achieved from single and mixed dye decolourisation experiments. The low, middle, and high levels of each variable were designed as -1, 0, +1 respectively and listed in Table 2.12. The design of experiments is listed in Table 2.13. The three significant variables X_1 , X_2 , X_3 and the mathematical relationship of the response Y to these variables can be approximated by the quadratic model equation:

$$Y = \beta_0 + \beta_1 X_1 + \beta_2 X_2 + \beta_3 X_3 + \beta_{11} X_1^2 + \beta_{22} X_2^2 + \beta_{33} X_3^2 + \beta_{12} X_1 X_2 + \beta_{13} X_1 X_3 + \beta_{23} X_2 X_3 \quad (\text{Eq. 1})$$

where

Y – predicted response,

β_0 – constant,

X_1 – pH,

X_2 – purified laccase (U/l),

X_3 – laccase mediator VA (mM),

β_1 , β_2 and β_3 – linear coefficients,

β_{11} , β_{22} and β_{33} – quadratic coefficient,

β_{12} , β_{13} and β_{23} – cross-coefficient.

The design experiments and data analysis were carried out using Minitab 15 (Minitab Inc, 2007). A total number of 15 experiments were necessary to determine the 10

coefficient in the model equation. In this study, experiments were run in duplicate, therefore 30 experiments were performed to estimate the 10 coefficients for the decolourisation of RB5. The statistical analysis was performed using multiple regressions and ANOVA with the software Minitab15.

Table 2.12: The levels of variables chosen for RB5 decolourisation.

Level	pH	[VA] (mM)	Laccase activity (U/l)
-1	5	0.00	100
0	7	1.25	200
+1	9	2.50	300

Table 2.13: The Box-Behnken design for the three independent variables.

Run Order	pH	VA(mM)	Laccase (U/l)
1	-1	1	0
2	0	-1	1
3	1	-1	0
4	-1	1	0
5	-1	-1	0
6	-1	0	1
7	1	1	0
8	1	0	-1
9	0	0	0
10	1	0	-1
11	-1	-1	0
12	1	0	1
13	0	0	0
14	0	-1	-1
15	0	-1	1
16	-1	0	-1
17	0	1	-1
18	0	0	0
19	0	1	-1
20	0	0	0
21	0	0	0
22	0	0	0
23	0	1	1
24	-1	0	1
25	0	1	1
26	1	1	0
27	0	-1	-1
28	1	-1	0
29	-1	0	-1
30	1	0	1

RB5 decolourisation experiments were performed in 96-well plates at room temperature (25°C). The total reaction mixture contained 160 µl RB5 in 100 mM sodium tartrate buffer, 20 µl VA and 20 µl laccase (Lac I) (see Tables 2.12 & 2.13). The decolourisation was monitored spectrophotometrically at one hour incubation time by recording at 590 nm. Different incubation time (5 minutes, 20 minutes, 30 minutes, 1 hour, 2 hours and 24 hours) were tested in preliminary studies before this experiment. The incubation time of one hour was found to be more suitable for this experiment design as the RB5 decolourisation took place within 1 hour with the addition of mediator VA.

CHAPTER 3: RESULTS

3.1 Introduction to Results

This Chapter starts with a section on strain selection for laccase production using statistic approach. The effect of various medium components and inducers on laccase production by *P. sanguineus*, *P. ostreatus* and *C. polyzona* in shaken flask fermentation is presented.

Subsequently, results of enhancement of laccase production by *C. polyzona* via optimising the type of inoculum, medium compositions and fermentation at various reactor scales are shown. In order to achieve high laccase activity for their industrial applications, fermentation of *C. polyzona* was scaled up to 2 litre, 5 litre, 20 litre and eventually to 150 litre stirred tank reactors.

The results of downstream processing leading to characterisation of laccase produced by *C. polyzona* are presented after the production section. This is followed by the application of the enzyme in textile dye bioremediation using mixed and single dyes.

3.2 Strain Screening in Shaken Flask Fermentation

3.2.1 Laccase Production by *P. sanguineus*

When *P. sanguineus* was grown in the 11 different production media in 500 ml shaken flasks, laccase production varied from 0 to 951 U/l. Table 3.1 demonstrates the maximum laccase activity achieved in different media. The time course of the laccase production under the best four conditions is shown and compared in Figure

3.1. On day 9, *P. sanguineus* produced laccase activity of 379 U/l in run no. 3 which was higher compared to other tested media. There was a decrease on day 10. In other runs, the laccase activity kept on increasing to higher levels. The best media composition was that of run no. 8 with the culture pH controlled at 5.0, where laccase activity reached its maximum of 951 U/l on day 27. The runs no. 5 and no. 9 reached the maximum laccase activities of 779 U/l and 367 U/l on day 26 and 16 respectively before they started to decrease.

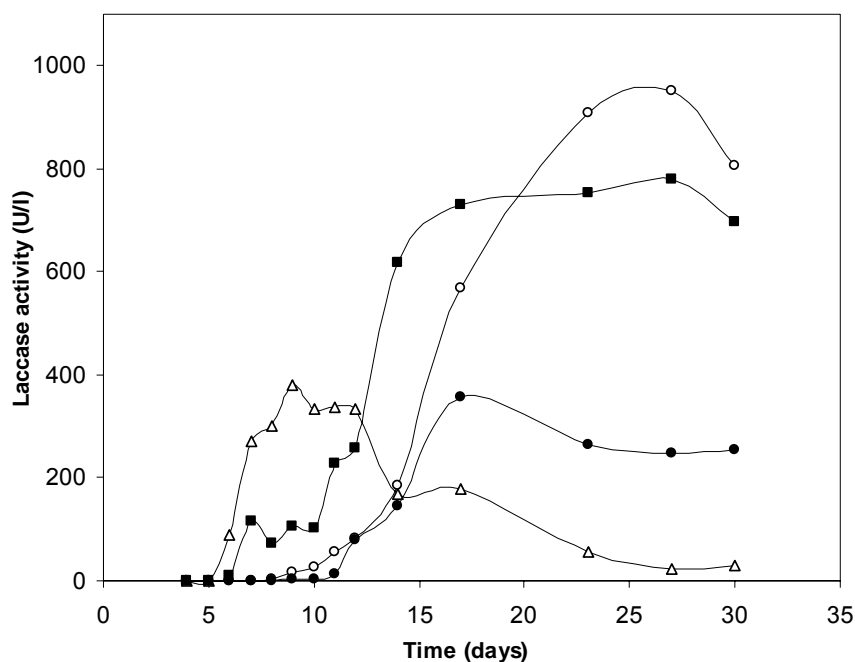

Figure 3.1: Time course of laccase production by *P. sanguineus* in the selected media in 500 ml shaken flask fermentation: run no.3 (Δ); run no.5 (\blacksquare); run no.8 (\circ); run no.9 (\bullet). Laccase assay was done in triplicate for all samples and results are expressed as the mean values within a standard deviation of less than 5%.

Table 3.1: Maximum laccase activity achieved in eleven tested media composition by *P. sanguineus*.

Run	Potato dextrose broth (g/l)	CuSO ₄ (mg/l)	Yeast extract (g/l)	MO (µg/l)	Buffer (pH)	Lactose (g/l)	Glucose (g/l)	Maximal laccase activity (U/l)
1	25	18.7	1	0	4.0	15	7	97
2	25	56.2	1	150	4.0	0	0	116
3	5	18.7	5	150	4.0	0	7	379
4	5	56.2	5	0	4.0	15	0	197
5	15	37.5	3	75	4.5	10	5	779
6	15	37.5	3	75	4.5	10	5	720
7	15	37.5	3	75	4.5	10	5	741
8	5	18.7	1	150	5.0	15	0	951
9	5	56.2	1	0	5.0	0	7	357
10	25	18.7	5	0	5.0	0	0	417
11	25	56.2	5	0	5.0	0	0	8

3.2.2 Laccase Production by *P. ostreatus*

The 11 media compositions were also applied to *P. ostreatus* for laccase production in 500 ml shaken flasks. As shown in Table 3.2, the results of laccase activity throughout the fermentation revealed that run no. 11 was the best for production of laccase with an activity of 700 U/l achieved after 14 days, whereas laccase production from other media compositions was hardly detectable in the culture supernatant. Figure 3.2 showed that there were several peaks observed in run no. 11 before maximum laccase activity was obtained on day 14. As for run no. 10, laccase activity slowly increased to 279 U/l on day 30. The fermentation was stopped on day 30 due to limited amount of culture broth in the shaken flasks.

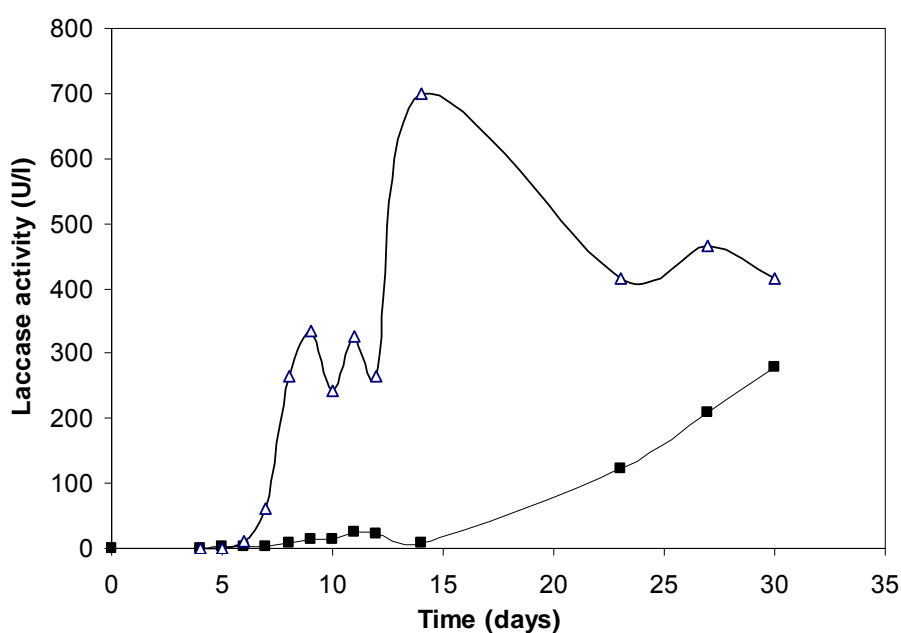

Figure 3.2: Time course of laccase production by *P. ostreatus* in the selected media in 500 ml shaken flask fermentation: run no.10 (■); run no.11 (Δ). Laccase assay was done in triplicate. Results are expressed as the mean values within a deviation of less than 5%.

Table 3.2: Maximum laccase activity achieved in eleven tested media composition by *P. ostreatus*.

Run	Potato dextrose broth (g/l)	CuSO ₄ (mg/l)	Yeast extract (g/l)	MO (µg/l)	Buffer (pH)	Lactose (g/l)	Glucose (g/l)	Maximal laccase activity (U/l)
1	25	18.7	1	0	4.0	15	7	-
2	25	56.2	1	150	4.0	0	0	-
3	5	18.7	5	150	4.0	0	7	-
4	5	56.2	5	0	4.0	15	0	-
5	15	37.5	3	75	4.5	10	5	12
6	15	37.5	3	75	4.5	10	5	24
7	15	37.5	3	75	4.5	10	5	-
8	5	18.7	1	150	5.0	15	0	-
9	5	56.2	1	0	5.0	0	7	-
10	25	18.7	5	0	5.0	0	0	279
11	25	56.2	5	0	5.0	0	0	700

- No laccase was detected.

3.2.3 Laccase Production by *C. polyzona*

The 11 different media compositions were also employed in *C. polyzona* fermentation for laccase production in 500 ml shaken flasks. Laccase production varied from 0 to 3807 U/l using 11 media compositions. Table 3.3 displays all conditions for laccase production with their maximum laccase production, among which run no. 4 resulted in the highest laccase activity of 3807 U/l on day 20.

Figure 3.3 shows time course of laccase production by *C. polyzona* in four media compositions, resulting in higher laccase activities in runs no. 2, no. 4, no.6 and no.11. A gradual increase of laccase activity was observed from day 7 to day 22 in run no. 2, no. 6 and no. 11 respectively, then the activity decreased gradually till the end of fermentation. Run no. 4 reached its peak of 3807 U/l on day 20 followed by a slight decrease till the end.

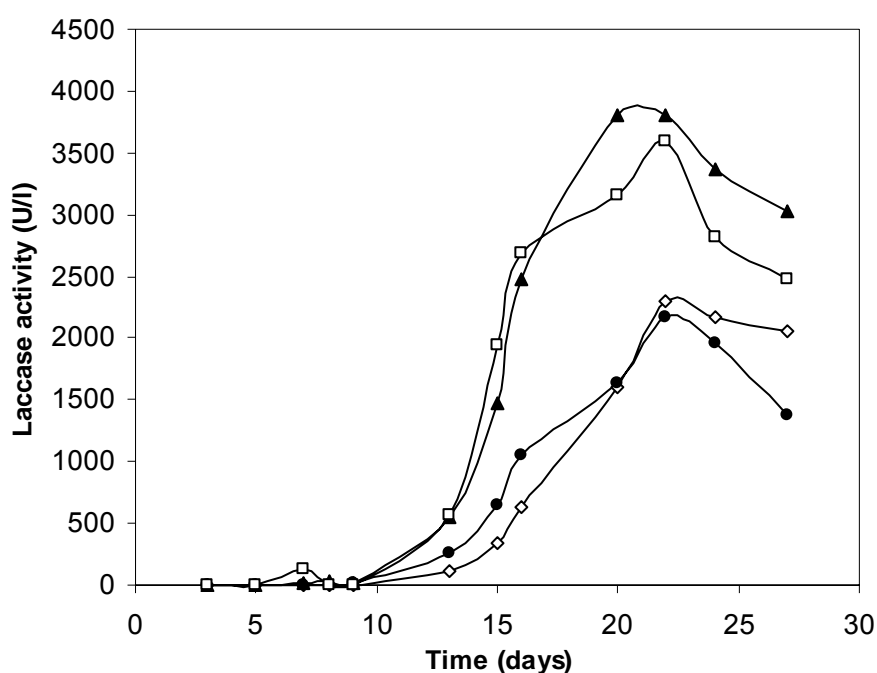

Figure 3.3: Time course of laccase production by *C. polyzona* in the selected media in 500 ml shaken flask fermentation: run no.2 (◇); run no.4 (▲); run no.6 (●); run no.11 (□). Laccase assay were done in triplicate. Results are expressed as the mean values within a deviation of less than 5%.

Table 3.3: Maximum laccase activity achieved in eleven tested media composition by *C. polyzona*.

Run	Potato dextrose broth (g/l)	CuSO ₄ (mg/l)	Yeast extract (g/l)	MO (µg/l)	Buffer (pH)	Lactose (g/l)	Glucose (g/l)	Maximal laccase activity (U/l)
1	25	18.7	1	0	4.0	15	7	804
2	25	56.2	1	150	4.0	0	0	2303
3	5	18.7	5	150	4.0	0	7	677
4	5	56.2	5	0	4.0	15	0	3807
5	15	37.5	3	75	4.5	10	5	1450
6	15	37.5	3	75	4.5	10	5	2163
7	15	37.5	3	75	4.5	10	5	2085
8	5	18.7	1	150	5.0	15	0	619
9	5	56.2	1	0	5.0	0	7	191
10	25	18.7	5	0	5.0	0	0	1954
11	25	56.2	5	0	5.0	0	0	3591

As a whole, media compositions for the runs no. 8, no. 11 and no. 4 resulted in the highest laccase activity from *P. sanguineus*, *P. ostreatus* and *C. polyzona* respectively in shaken flask fermentations.

Table 3.4: Optimal media compositions for laccase production by the three white rot fungi strains. R stands for medium and the subsequent number for the experimental run based on the experimental design.

Strains	Potato dextrose broth (g/l)	CuSO ₄ (mg/l)	Yeast extract (g/l)	Buffer (pH)	Lactose (g/l)	Glucose (g/l)
<i>P. sanguineus</i> (R 8)	5	18.7 (75 µM)	1	5	15	0
<i>P. ostreatus</i> (R 11)	25	56.2 (225 µM)	5	5	15	7
<i>C. polyzona</i> (R 4)	5	56.2 (225 µM)	5	4	15	0

In order to investigate the effect of ferulic acid and MO on laccase production by the three strains, further experiments were designed based on the optimum media composition found for each strain.

3.2.4 Evaluation of the Effect of MO and Ferulic acid on Laccase Production in Shaken Flask cultures of *P. sanguineus*

Figure 3.4 shows the laccase activity levels over the time course of the *P. sanguineus* fermentation. All the test combinations showed higher laccase activity compared to the control cultures where no ferulic acid and MO were added. Laccase activity increased significantly in the presence of both ferulic acid and MO. Laccase activity reached its first peak on day 16 followed by a remarkable decrease in all cases. A laccase activity of 13,197 U/l was obtained with the addition of 150 mg/l MO and 0.5 mM of ferulic acid (R3) on day 16, which was 70% higher compared to 1.0 mM ferulic acid and 75 mg/l MO (R2). The laccase level achieved in R3 was 3 and 0.6 times higher than the control (R8) and with only ferulic acid added (R6) cultures

respectively. As fermentation progressed, a second peak of laccase activity appeared in all cases. The second peaks indicated that the most effective combination was 75 mg/l MO and 0.5 mM of ferulic acid (R6) with a maximum laccase activity of approximately 30,000 U/l on day 20. It was found that ferulic acid played an inhibitory effect on laccase production by *P. sanguineus* at a concentration of 1 mM (R7). However, MO at a concentration of 150 mg/l increased the level of laccase production significantly, which was 88-fold increase in laccase levels when compared to the control.

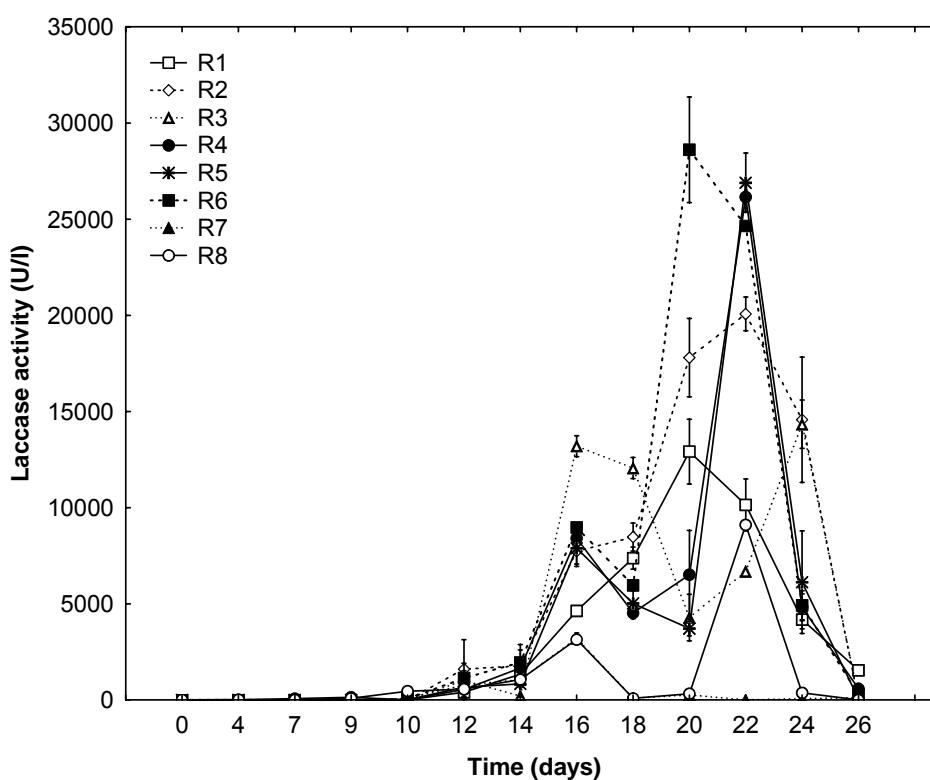

Figure 3.4: Time course of laccase activity produced by *P. sanguineus* under the different experimental conditions tested in the experiment. R1 (□): 0.5 mM ferulic acid and 75 mg/l MO; R2 (◇): 1.0 mM ferulic acid and 75 mg/l MO; R3 (△): 0.5 mM ferulic acid and 150 mg/l MO; R4 (●): 1.0 mM ferulic acid and 150 mg/l MO; R5 (☆): 150 mg/l MO; R6 (■) 0.5 mM ferulic acid and 75 mg/l MO; R7 (▲) 1.0 mM ferulic acid; R8 (○) Control. Figure represent means of triplicate experiments and bars the standard error.

Table 3.5 shows the analysis of variance (ANOVA) of laccase activity in *P. sanguineus* on day 20 evaluated by the regression analysis of a centre composed model. A significant effect was observed in the quadratic terms of the model. The effect of ferulic acid on laccase production was significant ($P < 0.1$). Furthermore, the effect of MO concentration was remarkably significant ($P < 0.001$). No significant effect was observed in the linear term of MO nor ferulic acid alone. It appears to be little synergy between the two factors for laccase enhancement ($P > 0.1$). The ANOVA indicates MO and ferulic acid play significant roles in enhancement of laccase production by *P. sanguineus* as individual components rather than having synergistic mode of action.

Table 3.5: Analysis of variance of the central composite experimental design for the laccases produced by *P. sanguineus*.

		MS	F	P
MO (mg/l)	(L)	7.51E+05	0.044	0.841
MO (mg/l)	(Q)	6.76E+08	39.163	0.000
ferulic acid (mM)	(L)	1.37E+07	0.794	0.402
ferulic acid (mM)	(Q)	7.26E+07	4.206	0.079
MO x ferulic acid		5.40E+06	0.313	0.593

MS = Mean square, F = Fisher value, P = Level of significance descriptive, L= linear term of the polynomial Q= quadratic term of the polynomial

Based on the experimental data, a response surface model is generated to indicate the optimal levels of MO and ferulic acid (Figure 3.5). The model agrees well with the experiment results in terms of the optimal concentration of MO and ferulic acid to produce laccases by *P. sanguineus*. The optimal conditions for MO and ferulic acid are 75 mg/l and 0.5 mM respectively. The response surface was generated from the mathematical model as below:

$$Y = 669.5 + 388.3X_1 - 2.6X_1^2 + 14557.3X_2 - 11851.7X_2^2 + 19.1X_1X_2$$

where Y is laccase activity (U/l), X_1 is the coded value of MO concentration and X_2 is the coded value of ferulic acid concentration.

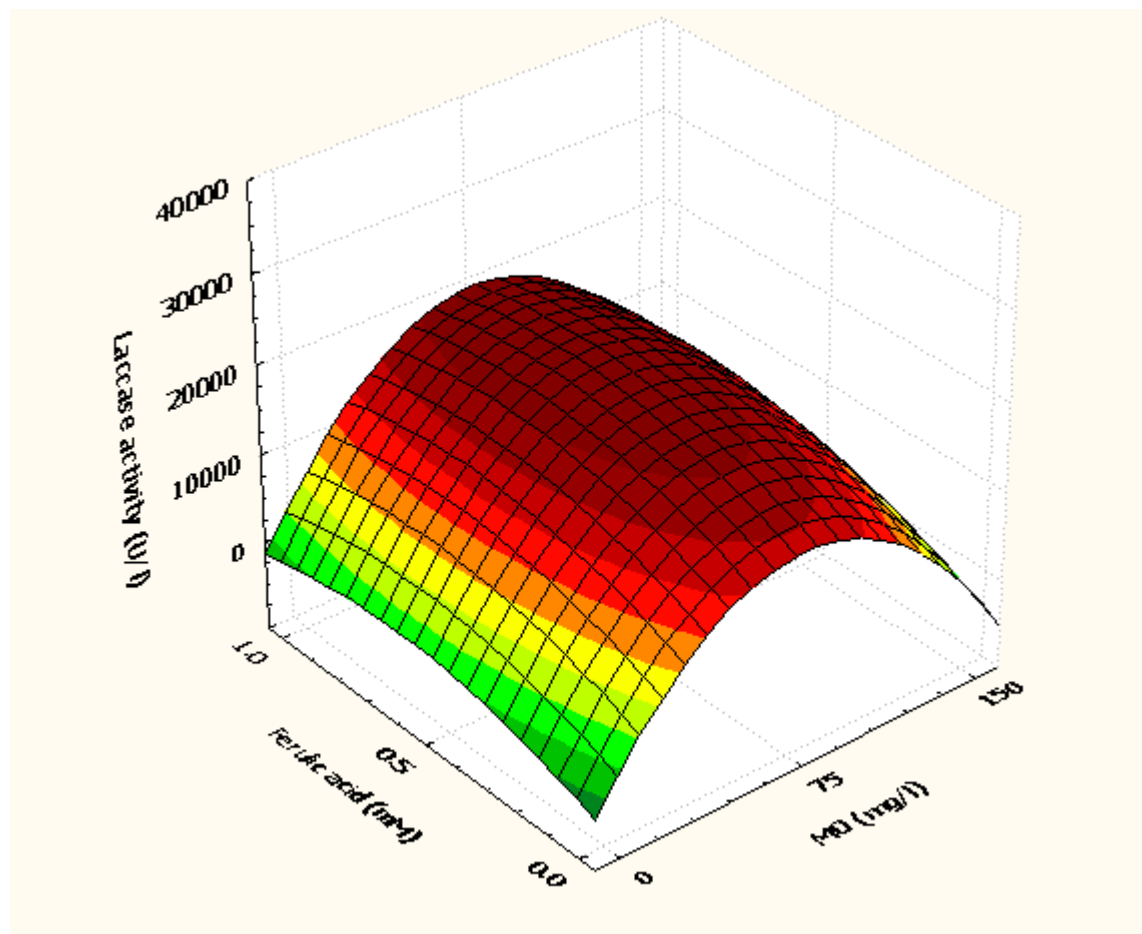

Figure 3.5: Response surface of laccases activity produced by *P. sanguineus* under the experimental conditions.

3.2.5 Evaluation of the Effect of MO and Ferulic Acid on Laccase Production in Shaken Flask Cultures of *P. ostreatus*

Figure 3.6 shows the laccase activity levels produced over the time course of *P. ostreatus* fermentation. The pattern of laccase production for all factors investigated was similar. The laccase activity peak was observed on day 16, which was 100% higher than the early peak on day 4. The highest laccase production of 7466 U/l was observed 75 mg/l MO and 0.5 mM ferulic acid addition (R6) at day 16, which was 1.8 and 2 times higher than control and with only 1.0 mM ferulic acid addition (R7) respectively.

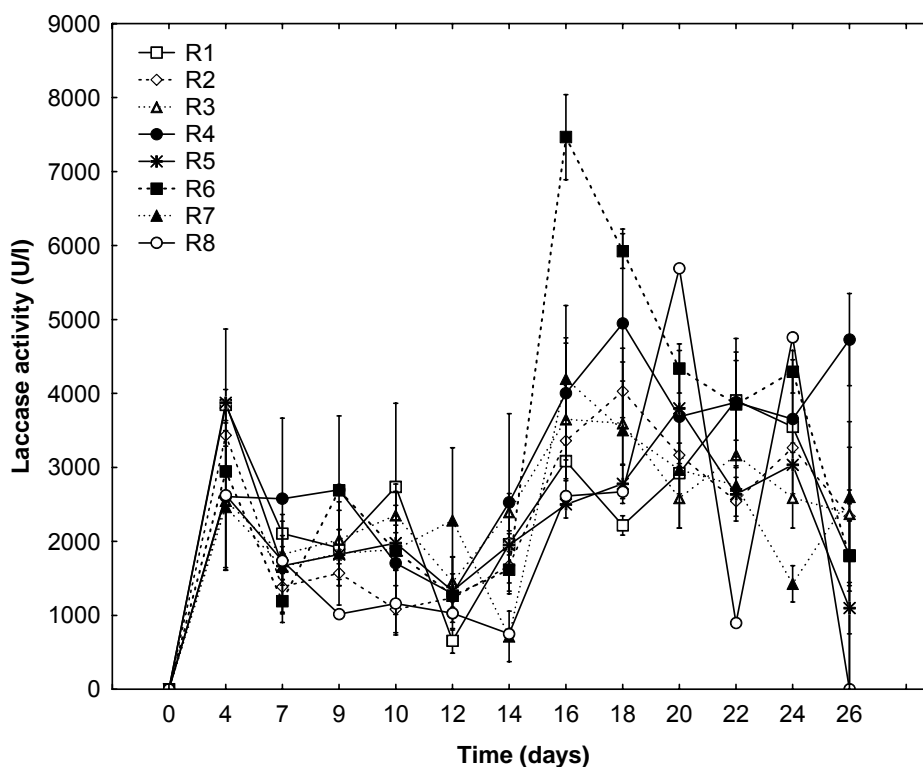

Figure 3.6: Time course of laccase activity produced by *P. ostreatus* under the different experimental conditions tested in the experiment. R1 (□): 0.5 mM ferulic acid and 75 mg/l MO; R2 (◇): 1.0 mM ferulic acid and 75 mg/l MO; R3 (Δ): 0.5 mM ferulic acid and 150 mg/l MO; R4 (●): 1.0 mM ferulic acid and 150 mg/l MO; R5 (⊗): 150 mg/l MO; R6 (■) 0.5 mM ferulic acid and 75 mg/l MO; R7 (▲) 1.0 mM ferulic acid; R8 (○) control. Figure represent means of triplicate experiments and bars the standard error.

Table 3.6 shows the analysis of variance (ANOVA) of the laccases produced by *P. ostreatus* cultures on day 16. The most important factors on laccase production were ferulic acid ($P < 0.05$) and MO ($P < 0.1$). The analysis showed that both ferulic acid and MO were most significant factors contributing to the enhancement of laccase production in *P. ostreatus* cultures with P -values of 0.014 and 0.059, respectively. However, there was no appreciable synergistic effect between ferulic acid and MO in overproduction of laccases.

Table 3.6: Analysis of variance of the central composite experimental design for the laccases produced by *P. ostreatus*

		MS	F	P
MO (mg/l)	(L)	345631	0.441	0.536
MO (mg/l)	(Q)	4638254	5.917	0.059
ferulic acid (mM)	(L)	2266861	2.892	0.150
ferulic acid (mM)	(Q)	10667230	13.608	0.014
MO x ferulic acid		759334	0.969	0.370

MS = Mean square, F = Fisher value, P = Level of significance descriptive, L= linear term of the polynomial Q= quadratic term of the polynomial

A response surface model (Figure 3.7) was designed based on the experimental data to evaluate the relationship between the elicitor MO and the inducer ferulic acid that resulted in highest laccase production. The response surface was generated from the mathematical model as below:

$$Y = 2787.0 + 39.3X_1 - 0.2X_1^2 + 1956.8X_2 - 2421.0X_2^2 - 0.5X_1X_2$$

where Y is laccase activity (U/l), X_1 is the coded value of MO concentration and X_2 is the coded value of ferulic acid concentration.

According to the response surface model shown in Figure 3.7, the optimal conditions of MO and ferulic acid were 75 mg/l and 0.5 mM respectively. This agreed with the experimental observation.

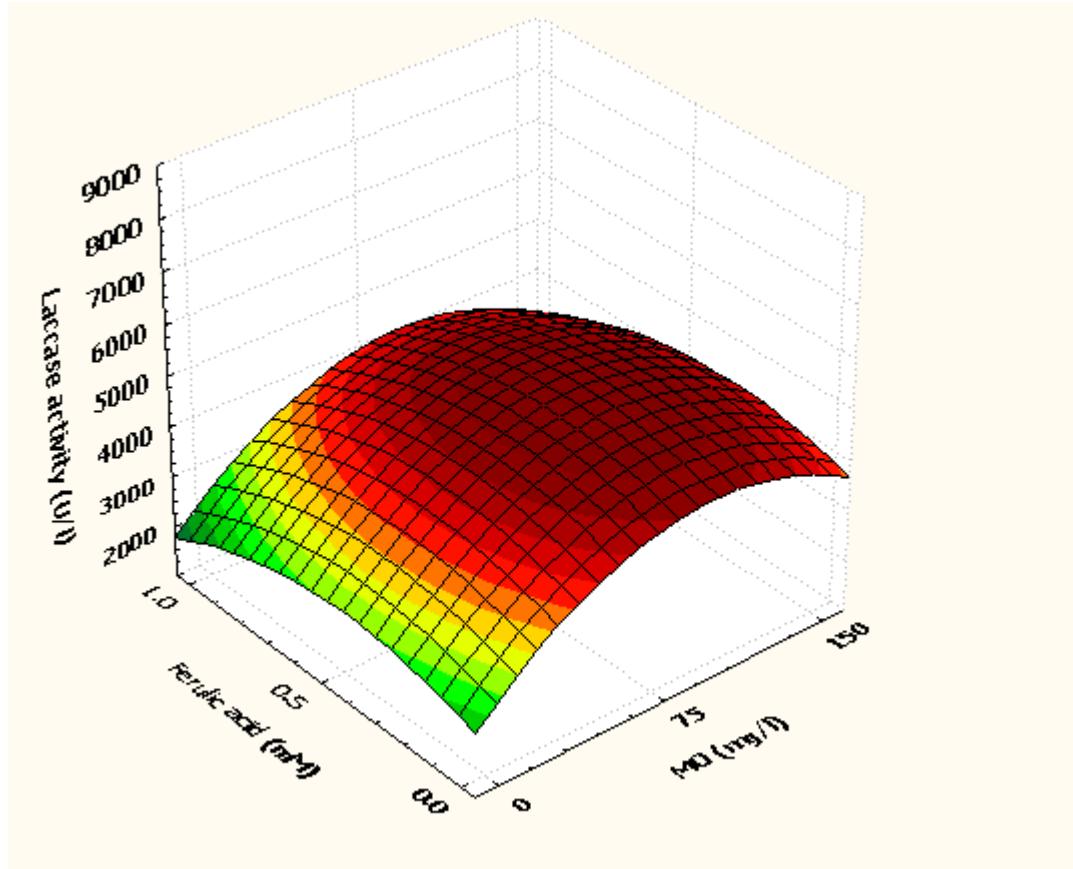

Figure 3.7: Response surface of laccases activity produced by *P. ostreatus* under the experimental conditions.

3.2.6 Evaluation of the Effect of MO and Ferulic Acid on Production of Laccase in Shaken Flask Culture of *C. polyzona*

Figure 3.8 shows the laccase activity profile over the time course for *C. polyzona* fermentation. The interaction of MO and ferulic acid was complex. It was found that ferulic acid at 1 mM as well as the combination of 0.5 mM ferulic acid and 150 mg/l MO inhibited production of laccases when compared to the control. Maximal laccase

activity of 6756 U/l was achieved when 150 mg/l MO and 1.0 mM ferulic acid (R4) were added to the culture. Increments of 1.5 and 0.3 times were obtained in R4 compared with the control and ferulic acid supplemented cultures respectively. In the case of R4, the onset of laccase production was 4 days earlier than the control where no MO and ferulic acid were used.

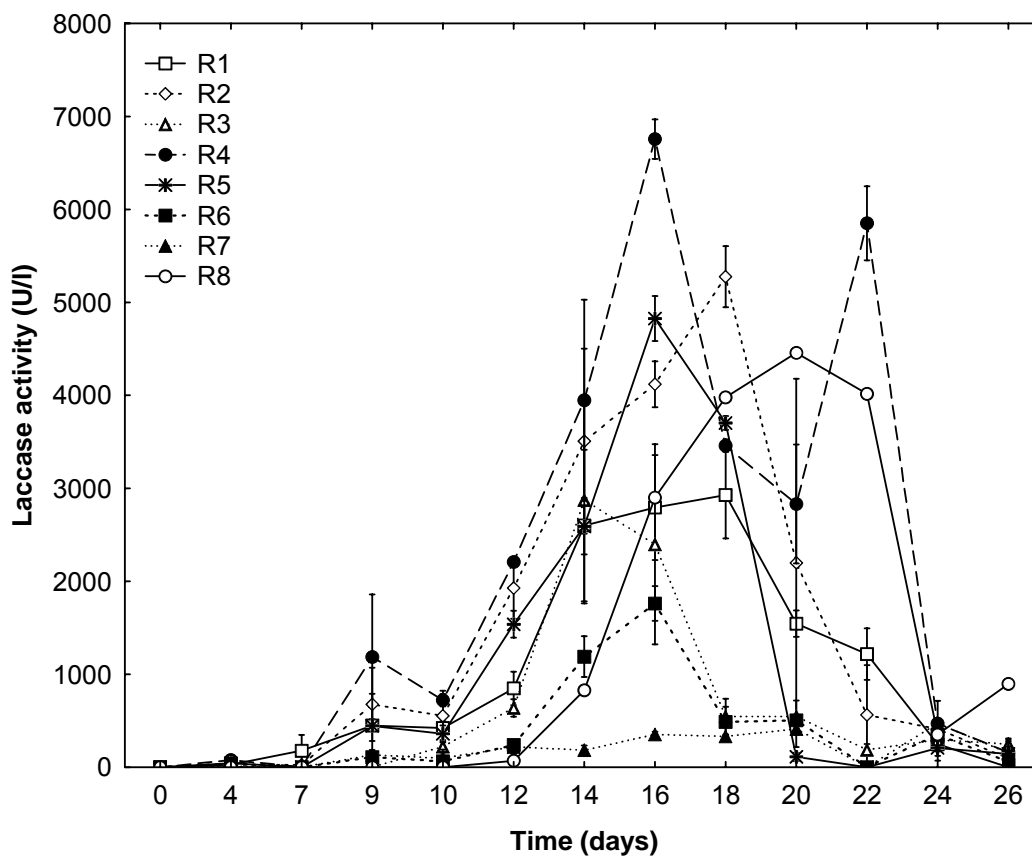

Figure 3.8: Time course of laccase activity produced by *C. polyzona* under the different experimental conditions tested in the experiment. R1 (□): 0.5 mM ferulic acid and 75 mg/l MO; R2 (◇): 1.0 mM ferulic acid and 75 mg/l MO; R3 (△): 0.5 mM ferulic acid and 150 mg/l MO; R4 (●): 1.0 mM ferulic acid and 150 mg/l MO; R5 (⊛): 150 mg/l MO; R6 (■) 0.5 mM ferulic acid and 75 mg/l MO; R7 (▲) 1.0 mM ferulic acid; R8 (○) control Figure represent means of triplicate experiments and bars the standard error.

Table 3.7 shows the analysis of variance (ANOVA) of the laccase activity by *C. polyzona* on day 16. The most important factors on productions of laccases were:

MO (Q) ($P < 0.1$), ferulic acid ($P < 0.0001$) and the interaction between ferulic acid and MO ($P < 0.01$). Both ferulic acid and MO had significant effect on production of laccases with P -values of 0.0001 and 0.0775, respectively. The synergistic effect of MO and ferulic acid was significant in enhancing production of laccases by *C. polyzona* with a P -value of 0.0060.

Table 3.7: Analysis of variance of the central composite experimental design for laccase produced by *C. polyzona*

		MS	F	P
MO (mg/l)	(L)	577244	0.8722	0.3747
MO (mg/l)	(Q)	2628168	3.9711	0.0775
ferulic acid (mM)	(L)	26895303	40.6380	0.0001
ferulic acid (mM)	(Q)	667678	1.0088	0.3414
MO x ferulic acid		8431840	12.7402	0.0060

MS = Mean square, F = Fisher value, P = Level of significance descriptive, L= linear term of the polynomial Q= quadratic term of the polynomial

A response surface model was constructed for laccase production by *C. polyzona*. The response surface was generated from the mathematical model as presented below:

$$Y = 3109.8 - 46.8X_1 + 0.2X_1^2 - 483.3X_2 + 2093.8X_2^2 + 30.6X_1X_2$$

where Y is laccase activity (U/l), X_1 is the coded value of MO concentration and X_2 is the coded value of ferulic acid concentration.

The response surface model (Figure 3.9) shows the contribution of MO to the enhancement of laccase production by *C. polyzona*. It was found that MO had limited

effect on laccase production in *C. polyzona* cultures and ferulic acid had stimulatory effect. The model agrees with the experimental data as the highest laccase production was observed when 150 mg/l MO and 1.0 mM ferulic acid were used in the experiment.

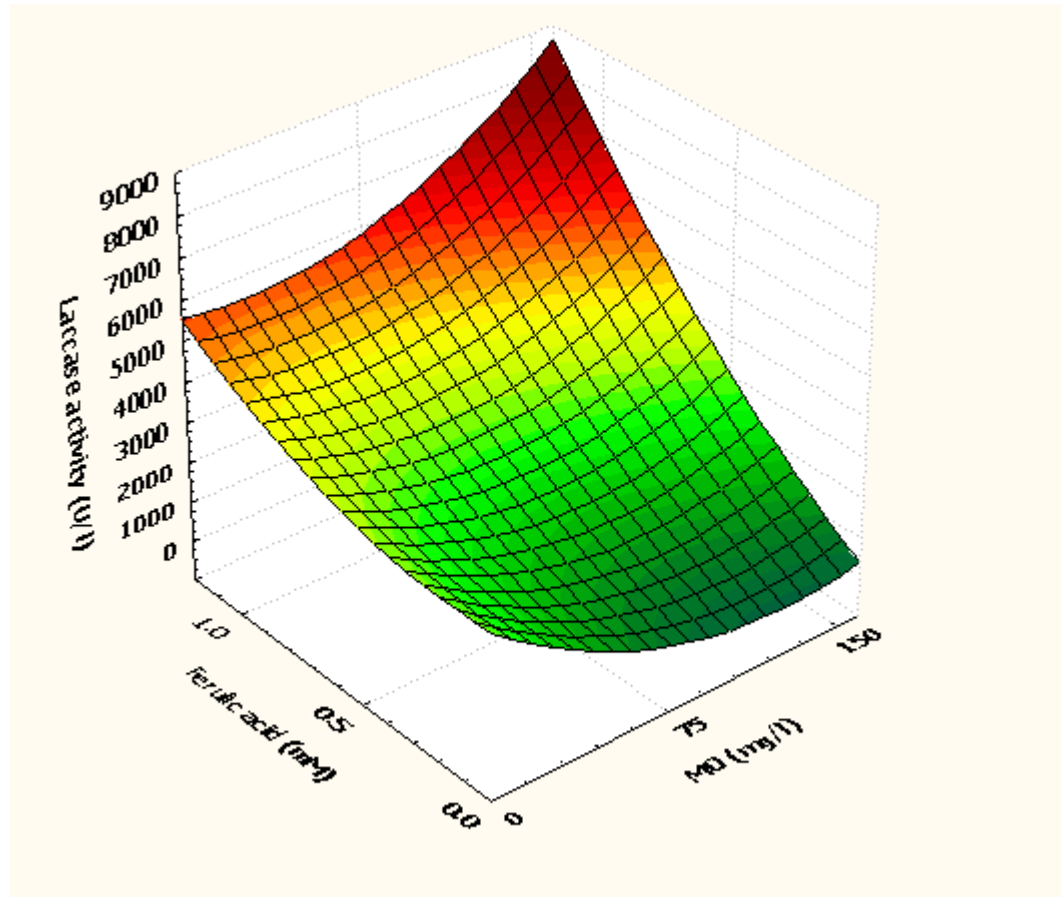

Figure 3.9: Response surface of laccases activity produced by *C. polyzona* under the experimental conditions

A central composite experimental design, that optimises the selected factors for maximal production, was successfully applied to MO as elicitor and ferulic acid as inducer in liquid cultures of white rot fungi with the scope for enhancing laccase

production. The central composite design was proved to be a good method for identification of statistically significant effect and the interaction between the chosen factors. Although MO enhanced laccase production in all the selected strains in this study, the effect was not generic. The elicitor as a single factor had significant effect when it was added to the liquid cultures of *P. sanguineus* and *P. ostreatus*. However, in the case of *C. polyzona*, the synergistic effect of the combined MO and ferulic acid was statistically significant for the increase in laccase production. The results suggest the potential use of MO to reduce the amount of ferulic acid and still produce high laccases activity. This study also showed that MO, either individually or combined with ferulic acid, enhanced laccase levels in three different white rot fungi strains. The highest increase in laccase production was obtained in liquid cultures of *P. sanguineus* followed by *P. ostreatus* and *C. polyzona*.

Due to its capability to produce the highest laccase activity among the three strains irrespective of the effect of ferulic acid and MO, the strain *C. polyzona* was selected for further investigation on overproduction of laccases in liquid fermentation at different scales.

3.3 Production of Laccases by *C. polyzona* in Shaken Flasks and Bioreactors

3.3.1 Shaken Flask Fermentation of *C. polyzona* for Laccase Production Using Conidia Inoculation in Standard Medium

Figure 3.10 shows a typical fermentation profile where the highest laccase activity of ~86,300 U/l was achieved after 16 days of the fermentation. The total protein concentration was 4.8 mg/ml, resulting in the maximal specific laccase activity of 18.08 U/mg. The onset of laccase production was on the 5th day when glucose in the production medium reached a relatively low concentration.

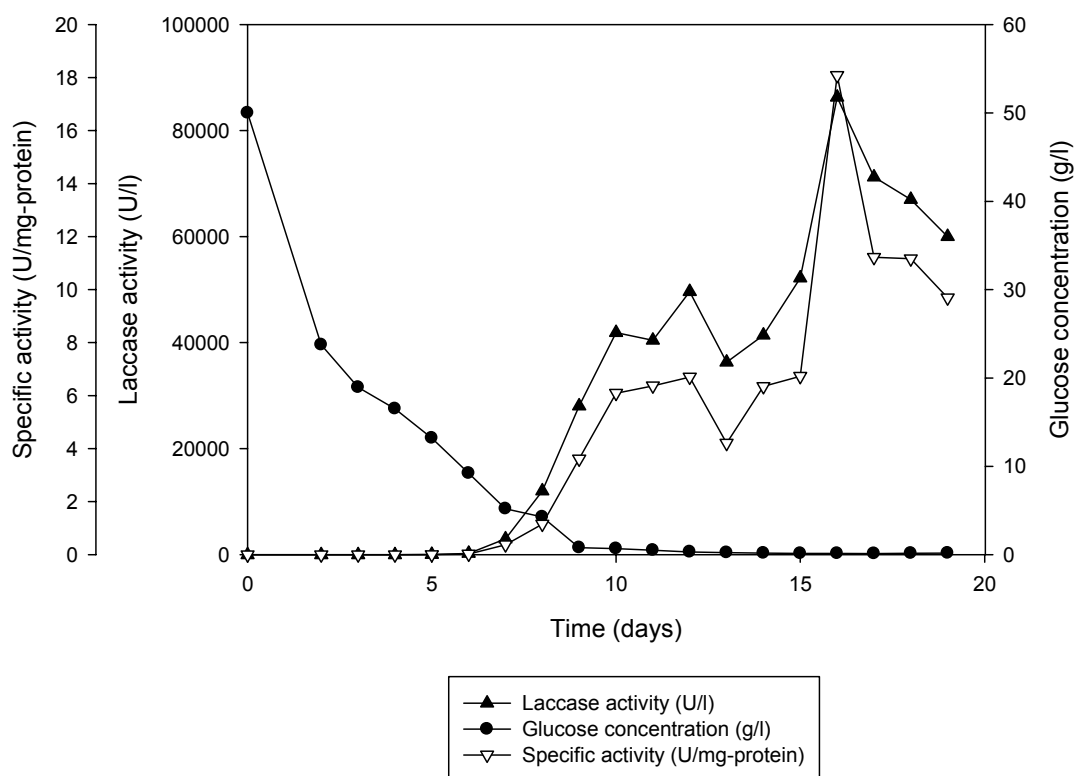

Figure 3.10: Laccase activity, glucose concentration and specific activity measured in the cultures of *C. polyzona* with conidia inoculation using standard medium. Laccase assay was done in triplicate for all samples and results are expressed as the mean values within a standard deviation of less than 5%.

3.3.2 Effect of Varying Glucose Concentration on Laccase Production in Standard Medium in Shaken Flask Fermentation

Figure 3.11 shows the effect of glucose concentration on laccase production by *C. polyzona* in shaken flask fermentations. It was observed that a decrease in the concentration of glucose from 50 g/l to 10 g/l resulted in 89% decrease in maximum laccase activity. In the case of glucose level at 10 g/l, maximum laccase activity of 27,600 U/l was produced, while 255,920 U/l of laccase activity was obtained from 50 g/l of glucose concentration. Laccase was not detected in shaken flasks with 50 g/l glucose after the 5th day, while it started to appear on 2nd day with 10 g/l glucose concentration. High glucose concentration might inhibit laccase activity, resulting in

prolonged lag phase before laccase biosynthesis.

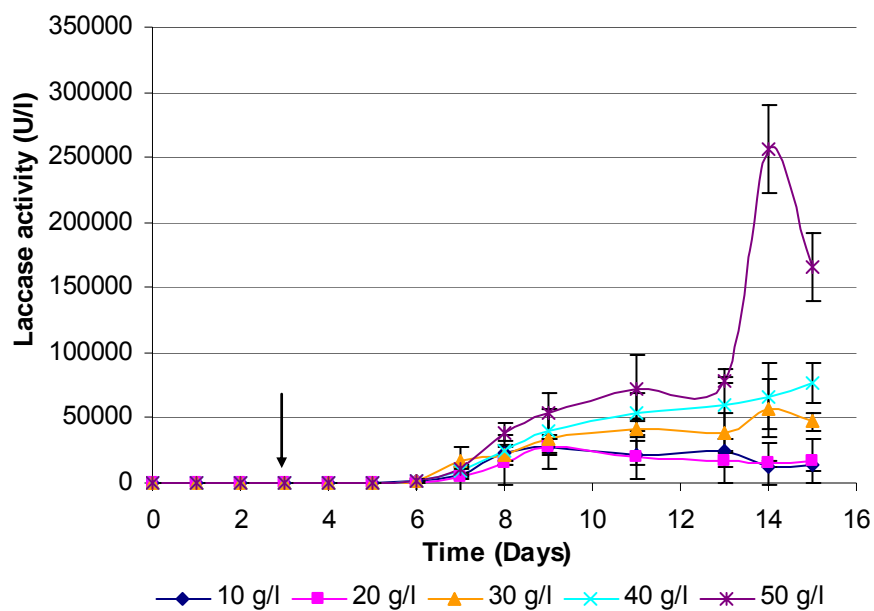

Figure 3.11: Effect of glucose concentration on laccase production by *C. polyzona* grown in 500 ml shaken flasks (Values shown represent average of triplicate samples, error bars represent standard deviation). The arrow indicates the addition of 1 mM ferulic acid on the 3rd day of fermentation.

As is evident from Figures 3.11 and 3.12, notable laccase activity was achieved when glucose concentration in the growth medium reached a relatively low level on day 14.

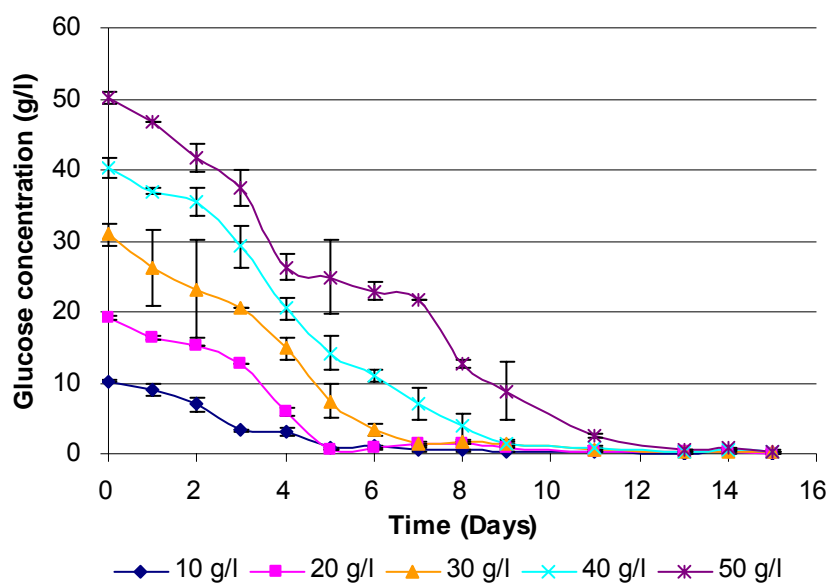

Figure 3.12: Glucose consumptions measured in shaken flask cultures of *C. polyzona* with different initial glucose concentration (Values shown represent average of triplicate samples, error bars represent standard deviation).

Mycelia dry cell weights were measured and compared after 15 days from different initial glucose concentration. As demonstrated in Figure 3.13, when *C. polyzona* was grown in glucose concentration of 50 g/l, the final cell dry weight (CDW) was 13.3 ± 0.06 g/l, which was the highest among all the fermentations.

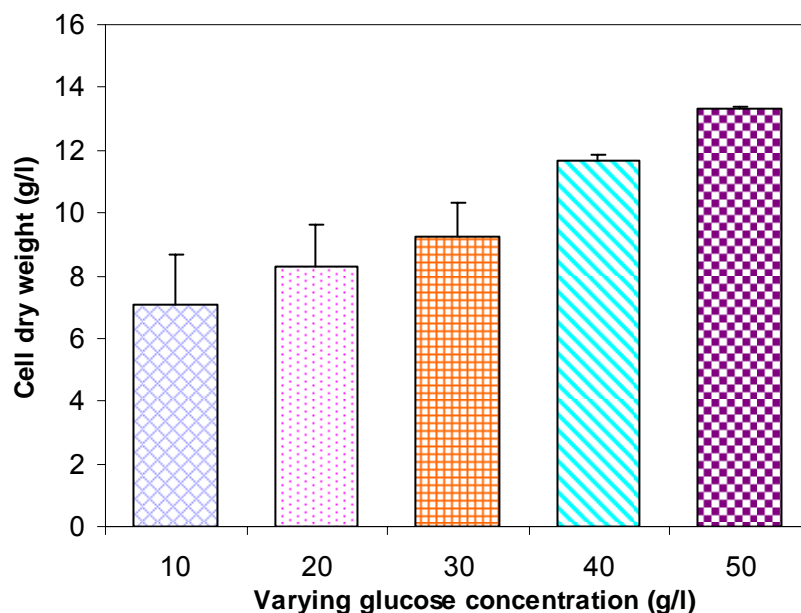

Figure 3.13: Biomass concentrations measured in shaken flask cultures of *C. polyzona* with different initial glucose concentration (Values represent average of triplicate samples, error bars represent standard deviation).

3.3.3 Effect of Wood Powder on Laccase Production in Shaken Flask Fermentation in Standard Medium (SM)

Figure 3.14 shows the laccase production with and without wood powder over the time course of the fermentation in 500 ml shaken flasks. A remarkable laccase activity on the wood powder supplemented fermentation was observed on the day 14, when first laccase peak appeared for both conditions. Average laccase activities of 239,000 U/l and 114,000 U/l were found on the wood powder and control fermentations on day 14, respectively. The addition of wood powder to the SM resulted in a 100 % increase in laccase activity in comparison to the control. After the addition of 0.1 mM ferulic acid and 1/10 concentration of SM into the culture broth on the 15th day, a second laccase peak of 65, 551 U/l was observed in wood powder supplemented fermentation, while there was a monotonic laccase increase in the control. The final cell dry weight was 18.2±0.37 and 15.2±0.09 g/l in wood powder fermentation and the control respectively. The total cell dry weight considered the

biomass in the culture broth as well as those grew on flasks' walls, which contributed greatly to the total amount.

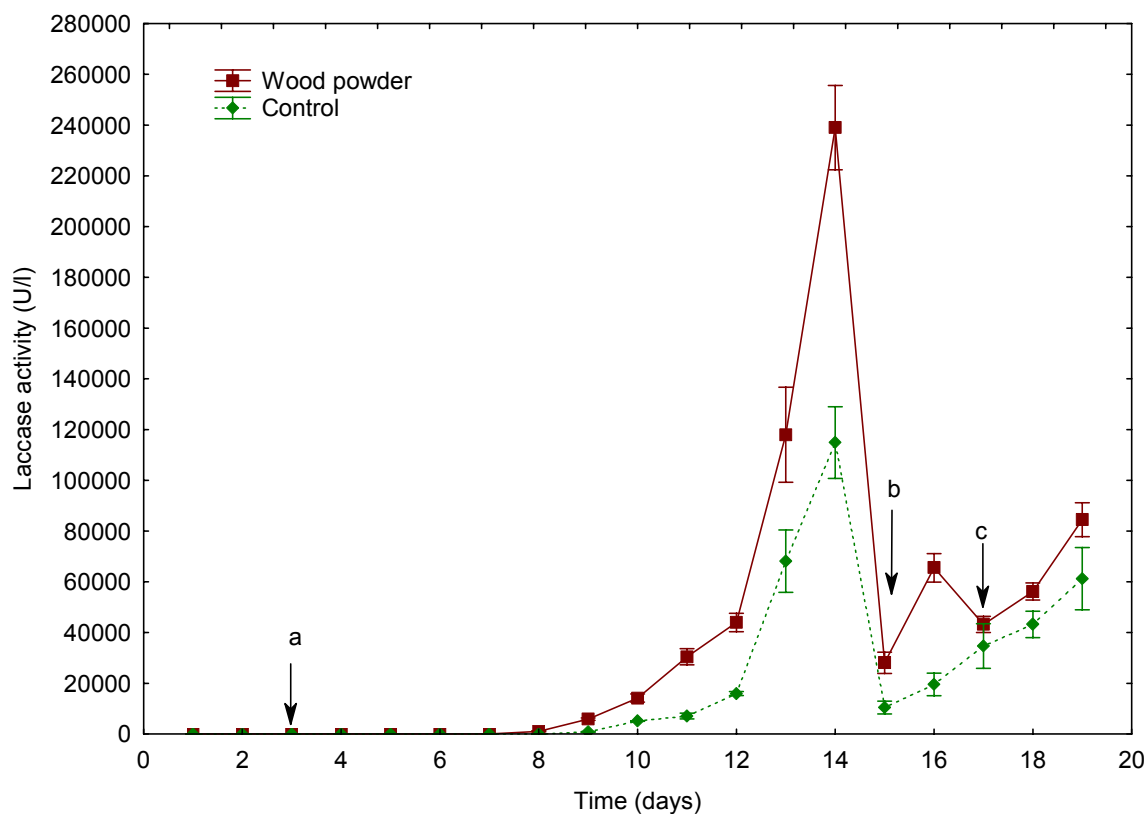

Figure 3.14: Time course of laccase activity in the control (no wood powder) and wood powder supplemented cultures in shaken flask fermentation. (■) wood powder + SM; (▲) control (SM). The fed-batch additions were: (a) 1mM ferulic acid; (b) 10 % (w/v) SM + 0.1 mM ferulic acid; (c) 1mM ferulic acid. The fermentation was carried out in triplicate and the error bars represent the standard error of the mean of triplicate samples.

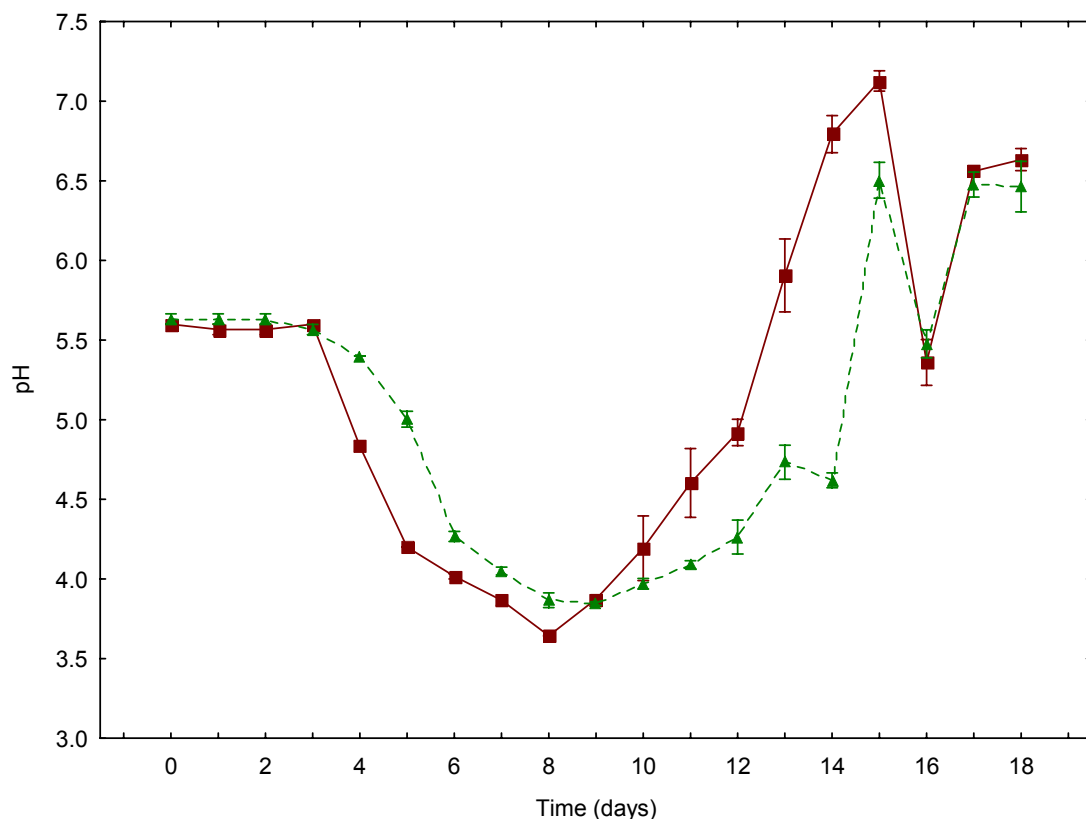

Figure 3.15: pH profiles in the control and wood powder supplemented cultures in shaken flask fermentation. (■) wood powder + SM; (▲) control (SM). The fermentation was carried out in triplicate and the error bars represent the standard error of the mean of triplicate samples.

Figure 3.15 shows the pH profiles over the fermentation period for control and wood powder supplemented cultures. The pH value over both conditions varied from 3.6 to 7.0. There was a decrease in pH after the addition of ferulic acid on day 3. The decrease continued until day 8 when an increase in pH was observed. The pH increased gradually till day 15. The addition of fresh medium on day 15 caused an immediate decrease in pH on day 16 followed by another increase to pH 6.8 and 6.5 in the wood powder supplemented and control cultures, respectively.

3.3.4 Effect of Inoculum Conditions on Laccase Production in 2 Litre Bioreactor

As shown in Figure 3.16 and Figure 3.17, laccase production started when glucose concentration was nearly depleted from the medium in both conidia and mycelium inoculated bioreactors. During the initial laccase production phase in the bioreactors, coinciding with glucose utilization period, laccase activity was low. When the consumption of glucose was nearly complete, laccase production increased considerably.

The pH was not controlled during the fermentations. As is evident from Figures 3.16 and 3.17, the pH profile shows similarity using different inoculation methods. The growth phase of *C. polyzona* was accompanied by a characteristic decrease in the culture pH from 5.5 to 4.0 for conidia inoculum, and from 5.5 to 3.6 for mycelium inoculum. The pH value started to increase when laccase synthesis began in both cases. The pH profile suggested that laccase production was associated with changes in pH of the culture during fermentation. It was suggested that the decrease of pH was due to the synthesis of primary metabolites, such as various organic acids, and the pH increase afterwards indicates that the secondary metabolism of the fungi is taking place (Tavares *et al.*, 2005).

The level of total soluble protein in the bioreactor with conidia inoculation was different from the one with mycelium inoculation. Total protein concentration obtained in conidia inoculated bioreactor when laccase activity reached the peak was 4.2 g/l, which was 40% higher compared to that in mycelium inoculated bioreactor. The figures showed that there was no notable difference observed in the maximum laccase activity using the two inoculum methods. Therefore, the higher total protein concentration contributed to the lower specific activity values obtained in the conidia inoculated bioreactor (21 U/mg-protein), which was 3-fold less than mycelia inoculated bioreactor (58 U/mg-protein) on day 24.

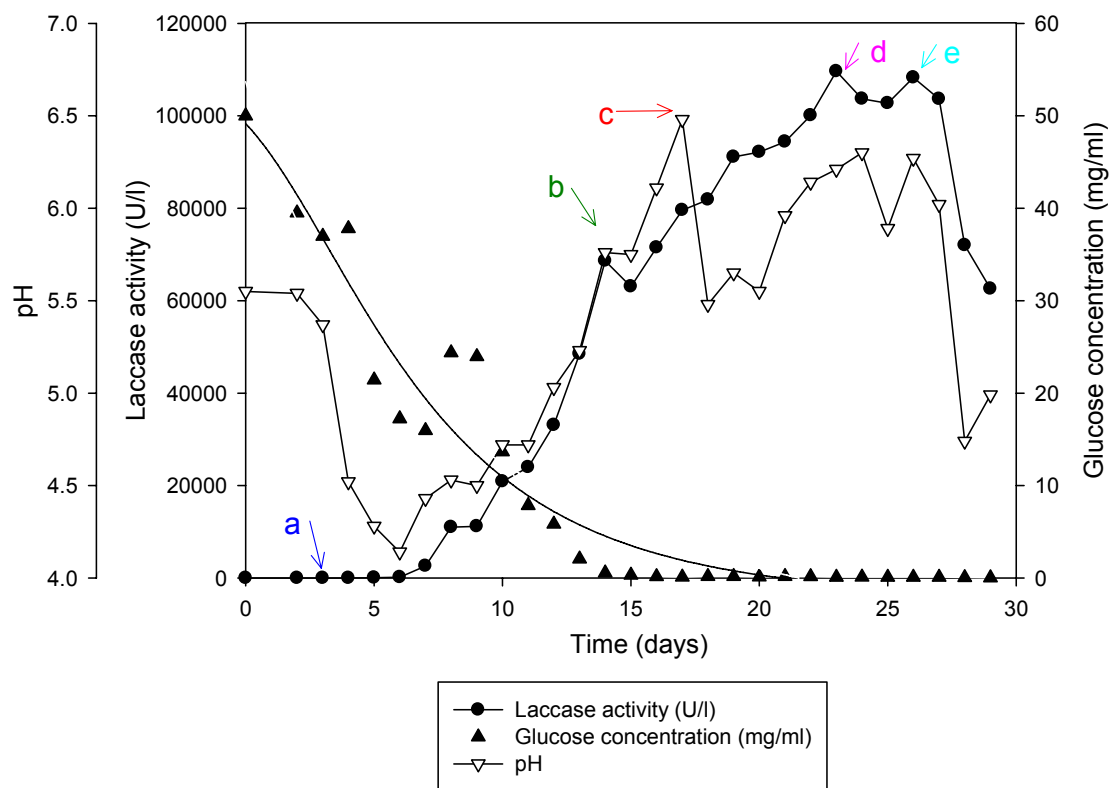

Figure 3.16: Laccase activity, glucose concentration and pH measured in 2 litre bioreactor using conidia inoculation. The fed-batch additions were: (a) 1mM ferulic acid; (b) 20 % SM; (c) 1mM ferulic acid; (d) 20% SM; (e) 1mM ferulic acid. All the assays were done in triplicate for all samples analysis and results are expressed as the mean values within a standard deviation of less than 5%.

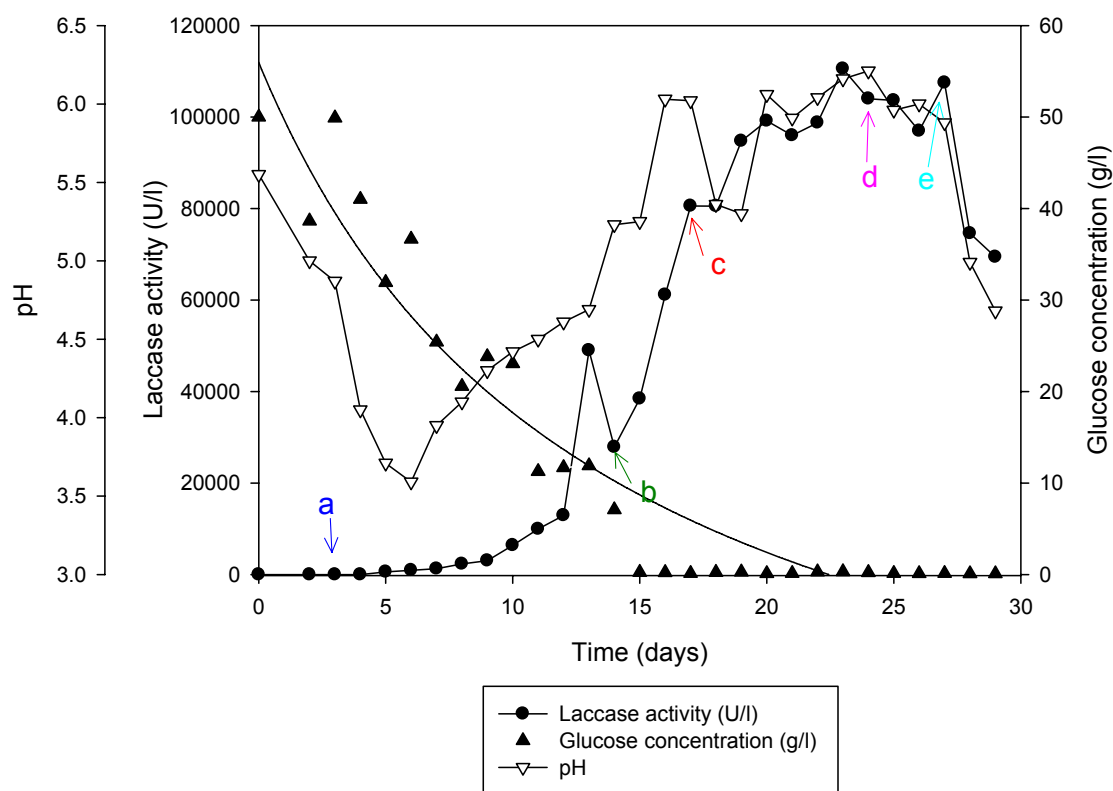

Figure 3.17: Laccase activity, glucose concentration and pH measured in 2 litre bioreactor using mycelia inoculation. The fed-batch additions were: (a) 1mM ferulic acid; (b) 20 % SM + 0.1 mM ferulic acid; (c) 1mM ferulic acid; (d) 20% SM; (e) 1mM ferulic acid. All the assays were done in triplicate for all samples analysis and results are expressed as the mean values within a standard deviation of less than 5%.

The time course of laccase production by *C. polyzona* in 2 litre bioreactors with two types of inocula is shown and compared in Figure 3.18. The addition times and concentrations of substrates and inducer are listed in Table 2.7. Laccase activity reached its first peak of 68,600 U/l in conidia inoculated bioreactor on day 14, followed by a slight decrease on day 15, while in the mycelium inoculated bioreactor, the laccase production increased to 49,000 U/l on day 13, then decreased to 27,900 U/l in the following day. The maximum laccase activities were 109,600 U/l and 110,500 U/l for conidia and mycelia inoculated bioreactors respectively on day 24. During the early stage of fermentation, laccase activity obtained in the bioreactor

with conidia inoculation was higher compared to that with mycelium inoculation. Both bioreactors behaved similarly in the latter stage of fermentation, where laccase activity increased gradually.

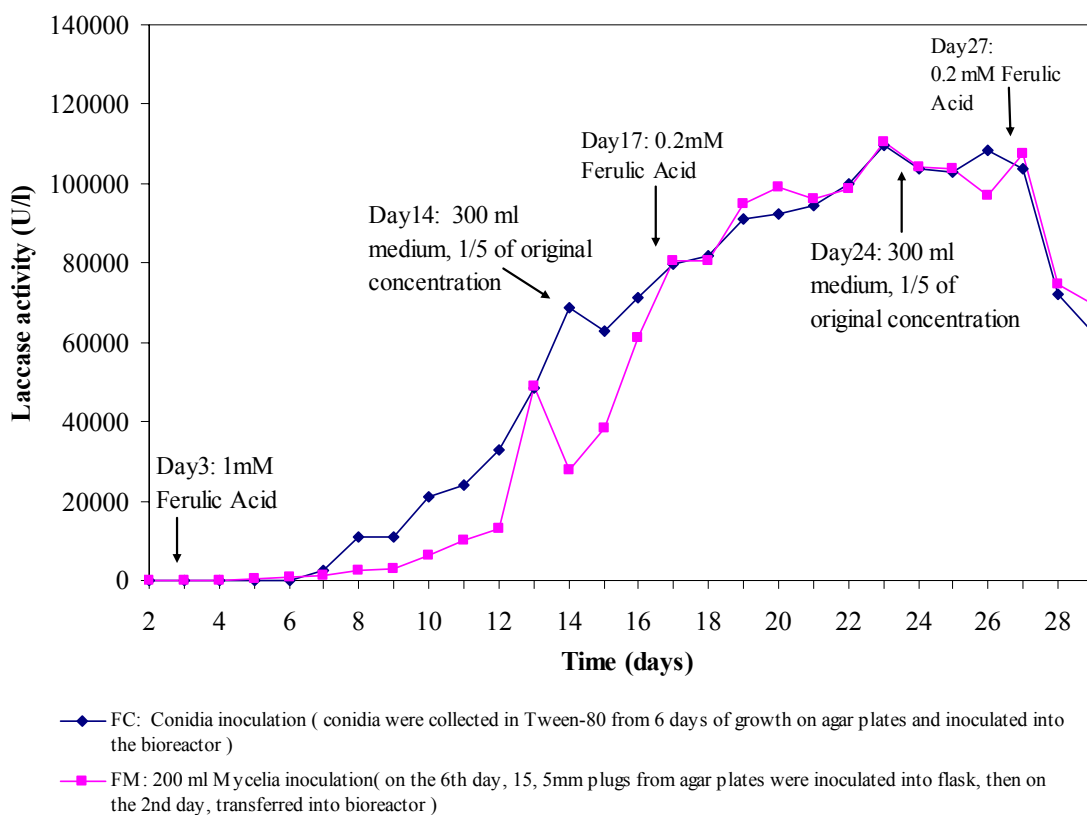

Figure 3.18: Time course of laccase activity of *C. polyzona* fed-batch culture in 2 litre bioreactors with two different inoculum preparations.

Figure 3.19 compares biomass concentration, in cell dry weight (CDW), between conidia inoculated culture and mycelia inoculated culture. The final biomass concentrations generated from both bioreactors were quite similar, resulting in 16.9 g/ml and 18.3 g/ml on day 29 for conidia and mycelia inoculated cultures, respectively.

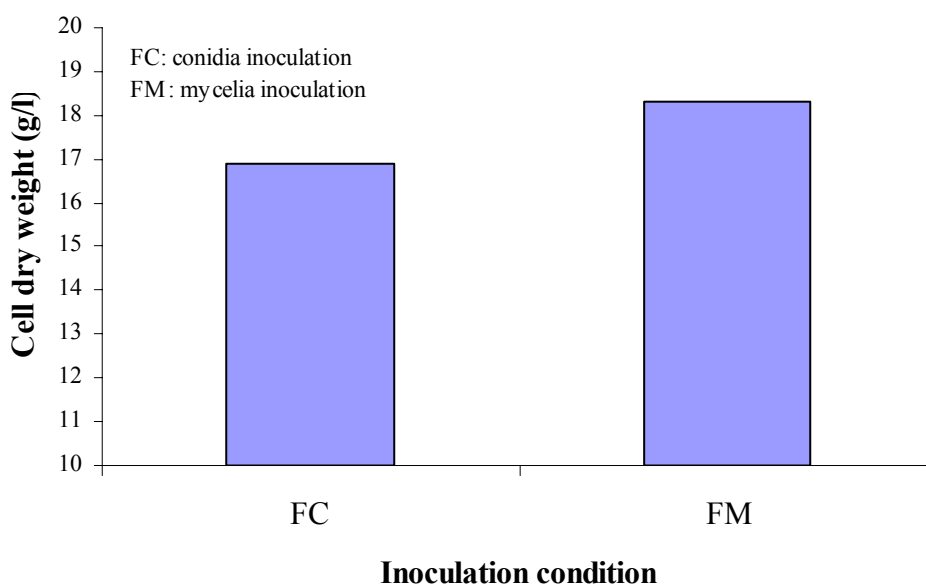

Figure 3.19: Final biomass obtained by dry cell weight produced in the 2 litre bioreactors.

3.3.5 Effect of Wood Powder on Laccase Production in 5 Litre Bioreactor

Figure 3.20 shows the laccase activity pattern over the course of fermentation time course in the wood powder supplemented and control cultures. The addition time and concentrations of substrates and inducer are listed in Table 2.8. Laccase production started on day 10 and the first peak appeared on day 13 with laccase activity of 22,500 and 21,800 U/l for the wood powder supplemented culture and the control respectively. Followed by a decrease in laccase activity on day 14, a second addition of fresh medium with 10 % SM + 0.1 mM ferulic acid was made to both bioreactors. A second peak of 78,800 U/l was observed in the bioreactor with wood powder, which was 4 times higher than the control. In an actively laccase producing state, 1mM ferulic acid was added on day 16. This resulted in an abrupt decrease in laccase levels. The highest laccase level during the entire fermentation was 205,900 U/l on day 18 in wood powder supplemented culture. The second peak of laccases in the control culture was 24,600 U/l on day 17. An addition of 20 % SM + 40 mg/l CuSO_4 on day 21 resulted in a slight increase in laccase levels in control culture but only

marginal increase was observed in the wood powder supplemented culture. It was found that the addition of twice the initial CuSO_4 concentration did not lead to an increase in the level of laccase activity in wood supplemented bioreactor. In contrast, a steady increase was observed in the control bioreactor from day 20 to 24 with laccase activity around 50,000 U/l. On day 29, the final peak of 84,900 U/l was achieved in the control, whereas the final peak of laccase production in the wood powder supplemented fermentation on day 28 was 137,400 U/l followed by rapid decrease. Although more carbon sources on day 29 with 20% of SM (without bactopeptone) was added, laccase activity kept on decreasing in the control culture toward the end of the fermentation. No increase of laccase activity was observed in the wood powder supplemented fermentation.

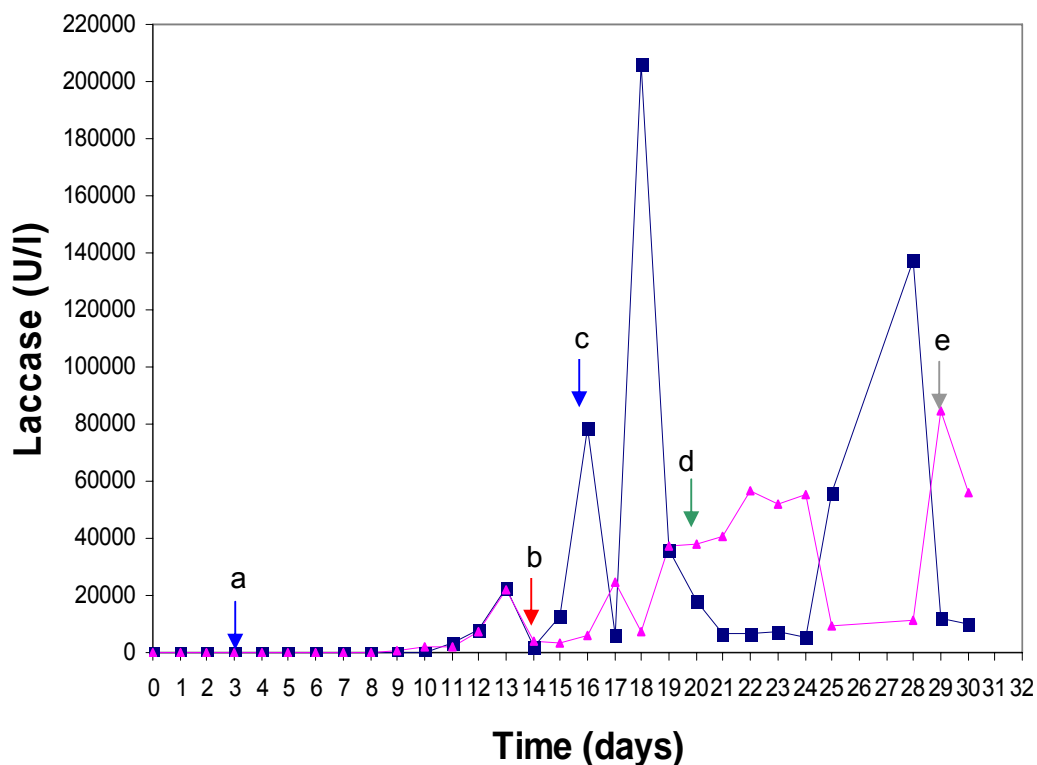

Figure 3.20: Time course of fermentations in 5 litre bioreactors. Symbols: (■) wood powder supplemented culture; (▲) control-standard medium (SM). The Fed-batch additions on the fermenters were: (a) ferulic acid 1mM; (b) 10% SM + 0.1 mM ferulic acid; (c) ferulic acid 1mM; (d) 20% SM + 40 mg/l CuSO₄; (e) 20% SM-without bactopectone. All the assays were done in triplicate for all samples analysis and results are expressed as the mean values within a standard deviation of less than 5%.

Figure 3.21 shows the pH profiles throughout the fermentation. Both cultures exhibited very similar profiles. The initial pH was 5.5 in both bioreactors followed by slight decrease due to the production of acids during the growth phase. The pH fluctuated in the range of 4.0-5.5 over the fermentation. The final pH was 5.0 in the wood supplemented culture. As in the control culture, a decrease of pH from 5.5 to 4.8 was observed after 27th day until the end of the fermentation.

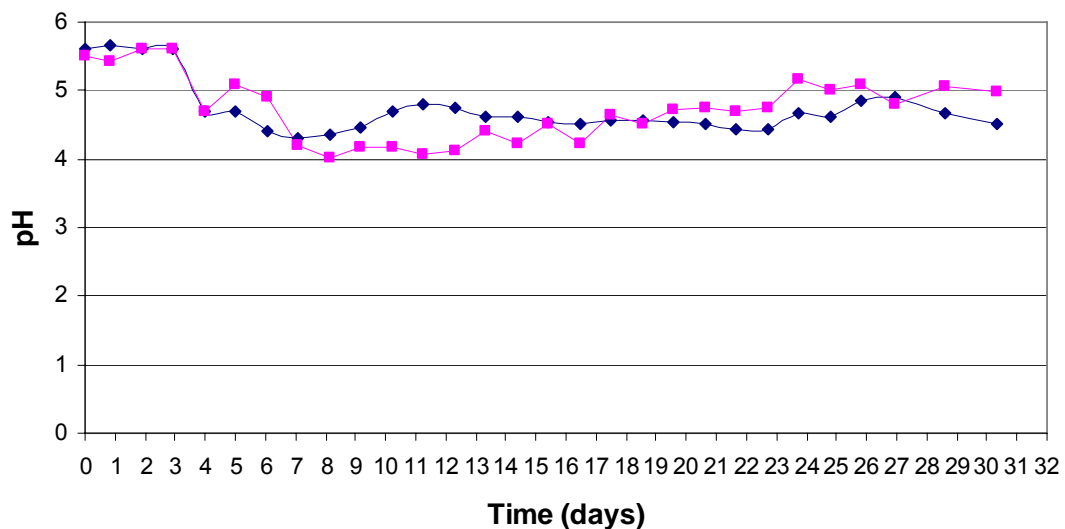

Figure 3.21: Time course of pH in the fermenters. Symbols: (■) wood powder supplemented culture; (◆) control (SM). All the assays were done in triplicate for all samples, the results are expressed as the mean values within a standard deviation of less than 5%.

Figure 3.22 demonstrates the biomass profiles throughout the fermentation. Overall, wood powder supplemented fermentation produced higher level of biomass compared to the control. The addition of ferulic acid was made when *C. polyzona* culture was at stationary phase. It was surprising that the addition of fresh medium on day 14 resulted in two opposite behaviour of the fungus. The fresh medium added to the control resulted in more biomass which was reflected in the further increase in cell dry weight. On the other hand, the fresh medium added to the wood supplemented culture seemed to be related to result in high laccase activity and a constant biomass over the period. The addition of 1 mM of ferulic acid on day 16 into the wood powder supplemented fermentation caused a decrease in biomass which continued to day 23. However, similar effect was observed on the control fermentation but for a shorter period till day 20, after which there was further growth. The addition of 40 mg/l CuSO_4 on day 20 did not affect fungi growth in the control culture, but further biomass decrease was observed in the wood supplemented culture. However, after day 23, growth in the wood powder supplemented culture restarted again and

continued until the end of the fermentation. The final biomass from wood powder supplemented fermentation was twice higher in comparison to the control culture.

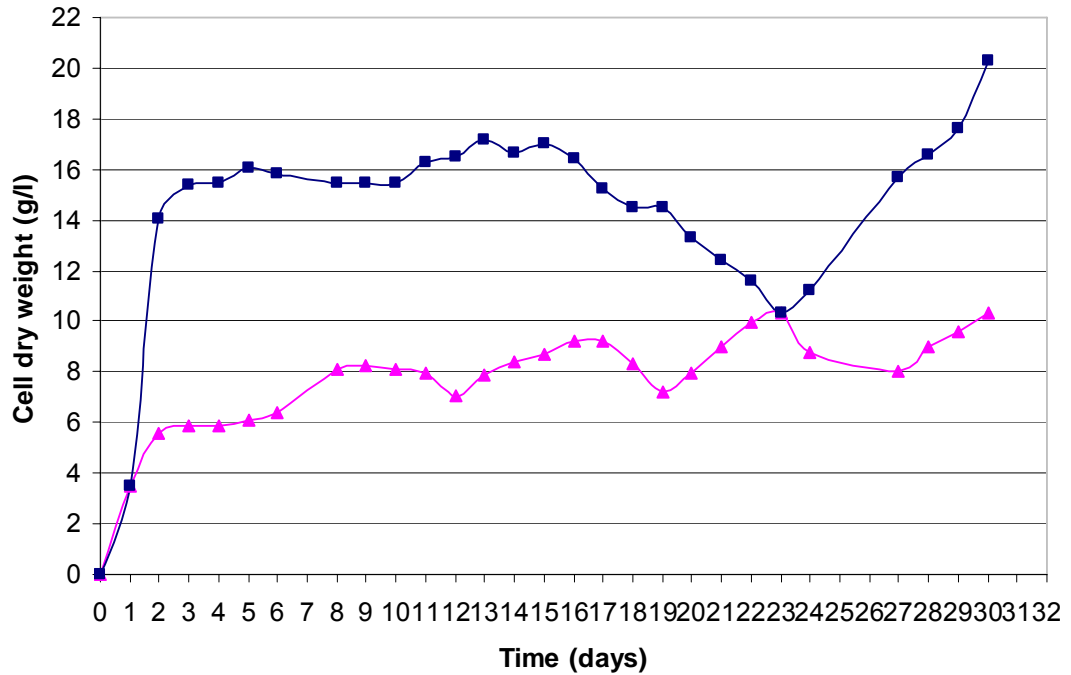

Figure 3.22: Time course of biomass in the fermenters. Symbols: (■) wood powder supplemented culture; (▲) control (SM).

Towards the end of the fermentation, there was a pressure build-up in the reactor due to the blockage of air outlet pipe by fungal growth. In order to prevent accumulation of pressure in the bioreactor, high pressure nitrogen was used to blast the air system, trying to remove the undesirable growth inside the air outlet pipe. There was also a blockage in the air inlet pipe at later stage and this is shown in Figure 3.23. Figure 3.23 demonstrated that fungi had grown outside and inside the air inlet pipe, which caused the blockage.



Figure 3.23: Blockage of air inlet system by anchored biomass in the air pipe.

3.3.6 Large Scale Production of Laccases in 20 litre bioreactor

For large-scale production of laccases by *C. polyzona*, the fermentation was firstly scaled up to 20 litre stirred tank reactor based on the strategy applied in 2 litre stirred tank reactor using conidia inoculum.

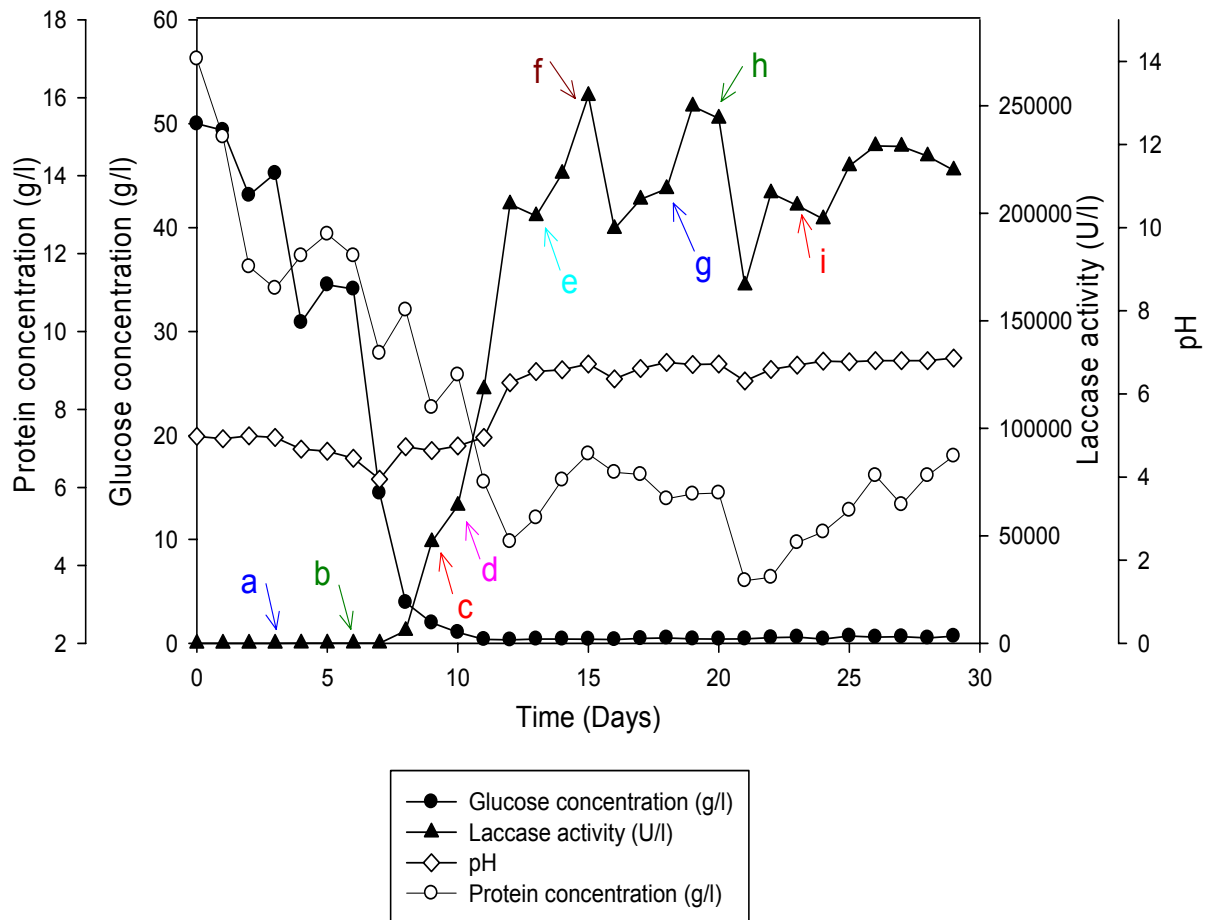

Figure 3.24: Fed-batch profile of *C. polyzona* and production of laccase in 20 litre stirred tank reactor. Arrows indicate the time of fresh medium and inducer addition. Symbols: (▲) laccase activity; (◇) pH; (●) glucose concentration; (○) total extracellular protein. (a) 1mM ferulic acid; (b) 20 % SM (w/v) ; (c) 0.2 mM ferulic acid; (d) 20 % SM (w/v); (e) 0.2 mM ferulic acid; (f) 20 % SM (w/v); (g) 0.2 mM ferulic acid; (h) 20 % SM (w/v); (i) 0.2 mM ferulic acid. All the assays were done in triplicate for all samples analysis and results are expressed as the mean values within a standard deviation of less than 5%.

A typical time course of fed-batch fermentation of *C. polyzona* in 20 litre stirred tank bioreactor is shown in Figure 3.21. The pH was not controlled during the fermentation. The initial pH was 5.0 and the pH continued to decrease to 4.0 as fermentation progressed. The pH profile suggested that laccase production was

associated with changes in respective pH. The decrease of pH was due to the synthesis of primary metabolites, such as various organic acids, and the pH increase afterwards indicates that an alternative secondary metabolism of the fungus is taking place (Tavares *et al.*, 2005). An increase in the pH value was observed when laccase synthesis began on day 7. There was a slight decrease when ferulic acid was added to the culture on day 9. However, further addition of ferulic acid on day 13, 18 and 23 did not result in pH decrease.

Laccase production was found to start when glucose concentration was almost consumed in the culture broth on day 6. Production increased rapidly over the following days. Laccase production reached its first peak of 204,300 U/l on day 12 followed by a slight decrease on day 13. After the addition of small amount of ferulic acid on day 13, laccase activity started to increase again and reached a maximum of 254,700 U/l on day 15. The addition of 20 % [SM] (w/v) on day 15 did not result in further increase of laccase activity but a slight decrease to 198, 800 U/l on day 16, which was accompanied by the decrease of pH. However, an increase of laccase activity was observed on day 17, resulting in 206,500 U/l. Further increase in laccase activity was observed until day 20 when another 20 % [SM] (w/v) was added into the bioreactor. This resulted in decrease in both laccase activity and pH on day 21 followed by slight increase on day 22. A dilution factor based on the volume of culture broth (before and after the addition of either ferulic acid or fresh medium) was taken into account in laccase activity calculation.

As it is shown in Figure 3.21, the total protein concentration decreased initially and fluctuated as fermentation progressed. The protein concentration was 6.9 g/l when laccase production reached the first peak on day 15 and it stayed within the range between 5.9 and 6.3 g/l in the following days.

3.3.7 Large scale production of laccases in 150 litre bioreactor

Further scale-up was performed in a 150 litre stirred tank reactor, trying to enhance laccase production in this trial run. This work was

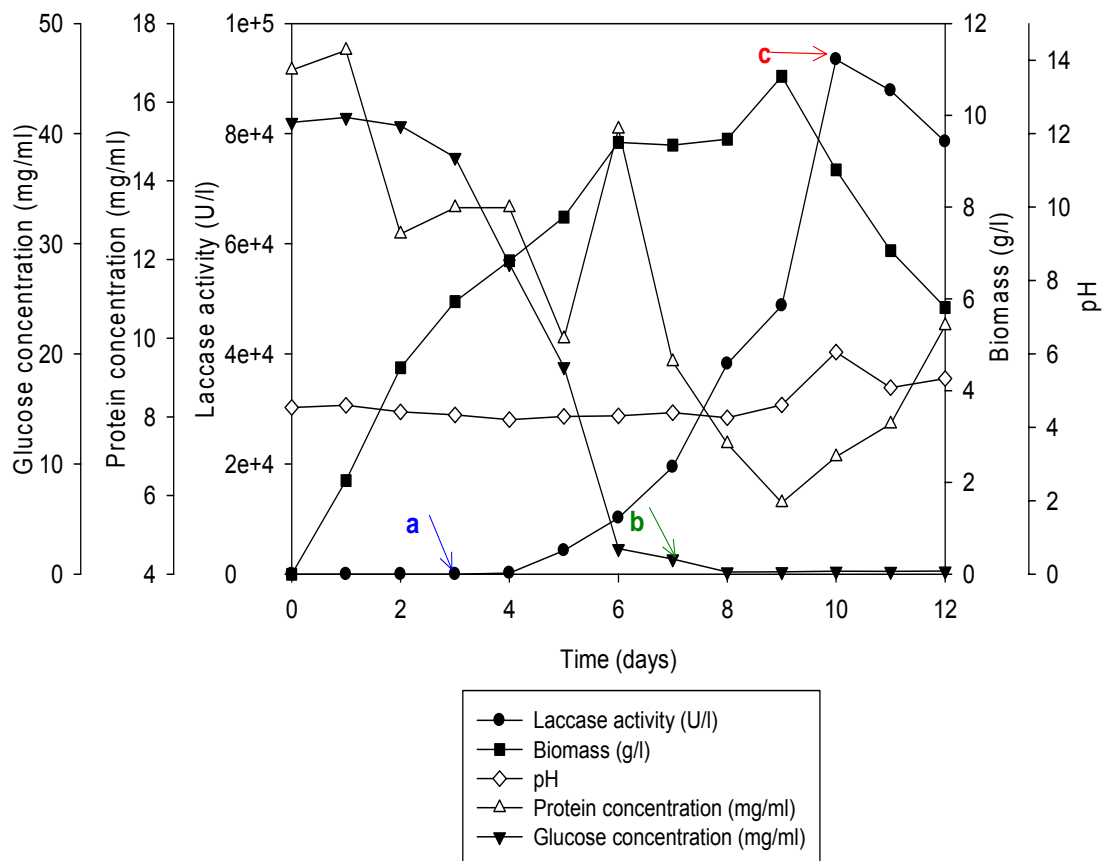

Figure 3.25: Fed-batch profile of *C. polyzona* and production of laccase in 20 litre stirred tank reactor. Arrows indicate the time of fresh medium and inducer addition. Symbols: (●) laccase activity; (◇) pH; (▼) glucose concentration; (△) total extracellular protein concentration. (a) 1mM ferulic acid; (b) 20 % SM; (c) 0.2 mM ferulic acid. All the assays were done in triplicate for all samples analysis and results are expressed as the mean values within a standard deviation of less than 5%.

Figure 3.25 shows profile of laccase activity, pH, glucose concentration and total extracellular protein concentration during fed-batch fermentation carried out in 150 litre stirred tank reactor. *C. polyzona* fermentation was scaled up to 150 litre stirred tank reactor in order to investigate the feasibility of achieving high activity level for laccase at pilot scale. However, the fermentation had to be terminated due to the air compressor failure on day 12. As indicated in Figure 3.31, the pH value decreased from 4.5 to 4.2 during growth phase, and started to increase as fermentation progressed. It shows that the production of laccase increased considerably when the glucose concentration became limited in the bioreactor. Similar results were observed both in 2 litre and 20 litre fermentation of *C. polyzona*. Apparently, laccase synthesis is inhibited when the glucose present in the medium is above certain level. The maximum laccase activity of 93,470 U/l was achieved on day 10. The onset of *C. polyzona* fermentation carried out in 150 litre bioreactor was much earlier than that in 20 litre bioreactor.

3.4 Purification and Characterization of Laccases from *C. polyzona*

3.4.1 Enzyme Purification

The purification process was started with 200 ml crude culture broth containing laccase activity of 128,000 U/l from batch fermentation in 5 litre stirred tank reactor using standard medium. Ammonium sulphate precipitation, hydrophobic interaction chromatography (HIC) and anion exchange chromatography (AEX) were used sequentially.

Laccase I (Lac I) and Laccase II (Lac II) were purified to electrophoresis homogeneity according to the procedure summarised in Table 3.8.

Table 3.8: Purification of laccase isoenzymes from *C. polyzona*.

Purification step	Protein (mg/ml)	Volume (ml)	Total protein (mg)	Total activity (U)	Specific activity (U/mg)	Yield (%)	Purification factor (fold)
Culture Broth	6.26	200	1252	25600	20	100	1
Ammonium Precipitation	12.40	10	124	34907	282	136	14
HIC (Phenyl Sepharose)							
HIC (wash)	0.06	130	8	186	24	1	1
HIC (elution)	0.19	162	31	19840	645	78	32
AEX (MonoQ)							
AEX elution peak 1	0.06	10	4.5	2097	466	8	23
AEX elution peak 2	0.06	5	0.3	550	1763	2	86
Total			4.8	2647	550	10	109

Laccases were separated from the most plentiful impurities after the HIC step, which included a brown pigment absorbing strongly at 280 nm. The main peak pool from the elution step of HIC resulted in 32 fold increase in laccase purity. There was a small peak with laccase activity appeared during wash step of HIC, however, it was not processed further due to its low laccase activity and protein concentration. As demonstrated in Figure 3.26, there were several protein peaks during Mono Q step, two of which showed laccase activity. At the end of purification process, 109-fold increase was achieved. The overall yield of laccases from culture broth was 10%.

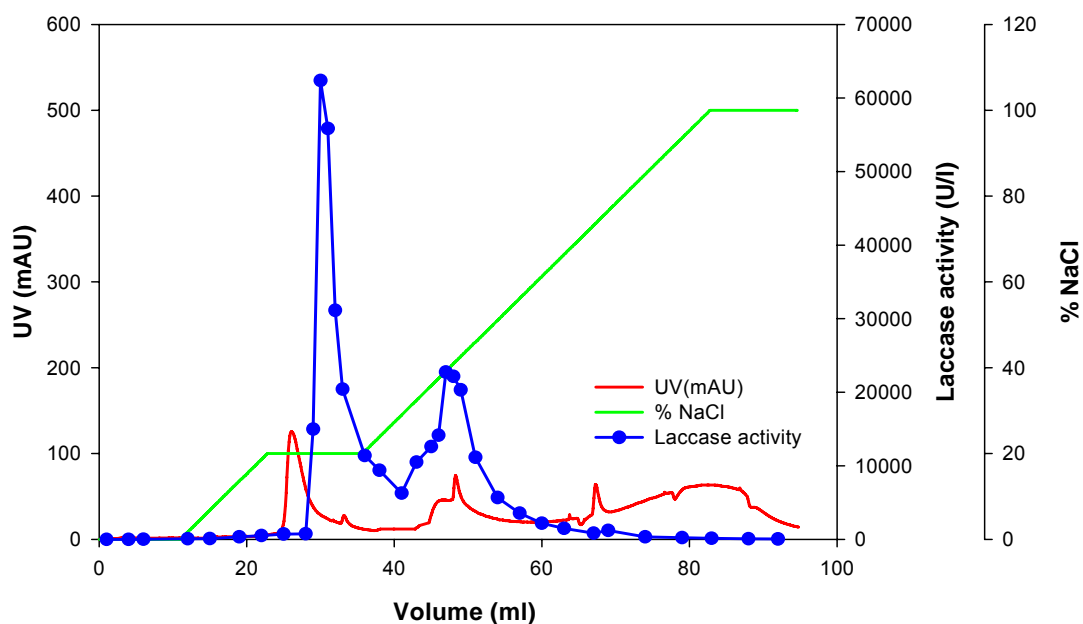

Figure 3.26: Purification of laccases from *C. polyzona* by Mono-Q chromatography after HIC. Absorbance at 280 nm (red line), the NaCl gradient (green line) and the laccase activity (●) are as indicated.

3.4.2 Properties of Lac I and Lac II

The purified Lac I and Lac II were purified to homogeneity and further proved on SDS-PAGE (Figure 3.27). Their molecular masses were estimated by comparison with the molecular weight standard. It was determined that Lac I and Lac II had an apparent molecular mass of 63 kDa. The arrow indicates the presence of *C. polyzona* laccases.

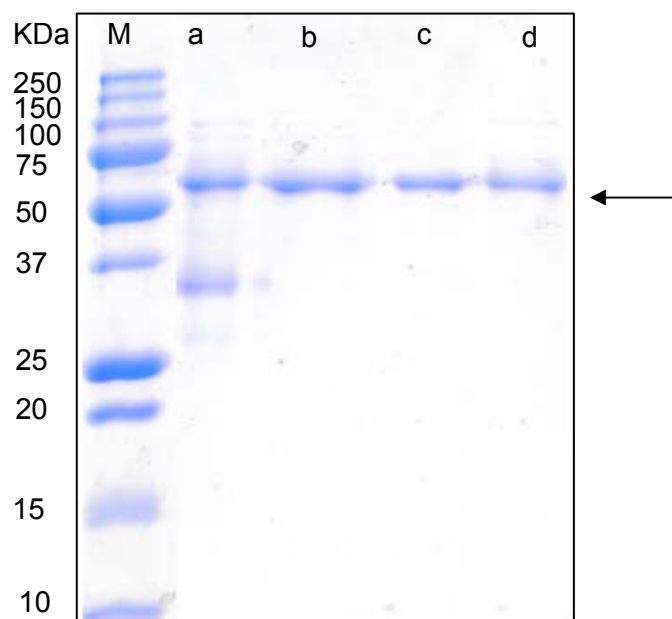

Figure 3.27: Determination of molecular mass of purified laccase isoenzymes from *C. polyzona*. a, crude sample; b, HIC (elution); c, peak 1(Mono Q elution); peak 2 (Mono Q elution).

Based on gel filtration chromatography on Superdex-200 (Figure 3.28), the molecular masses of native Lac I and II were estimated to be 60 and 66 kDa respectively, indicating that both isoenzymes are monomeric proteins.

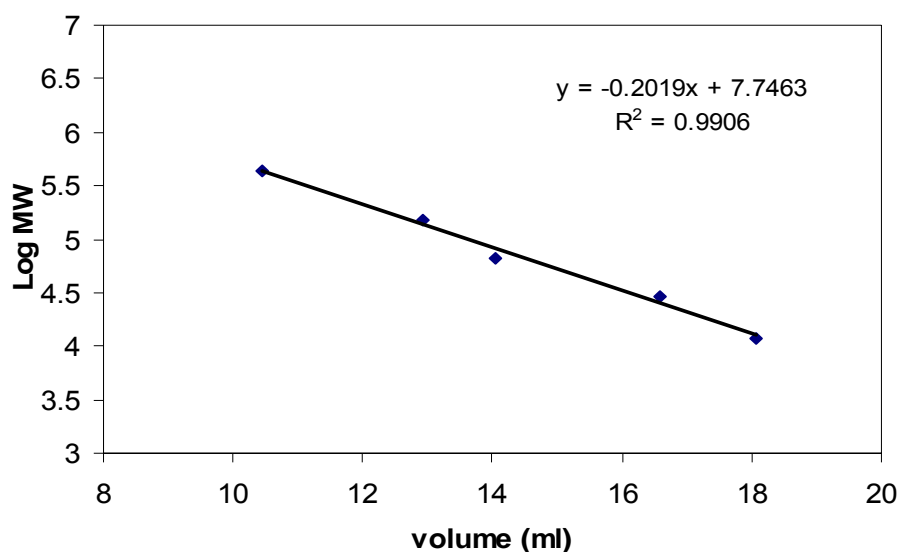

Figure 3.28: Calibration curve for determination of molecular mass for laccases from *C. polyzona* relative to the elution volume of protein standards on a pre-packed size exclusion chromatography column.

Homogeneity of *C. polyzona* laccases were further confirmed by iso-electric focusing (Figure 3.29). The apparent iso-electric point (pI) for both Lac I and Lac II were determined to be 4.2 based on the standard. The arrow indicates the presence of *C. polyzona* laccases.

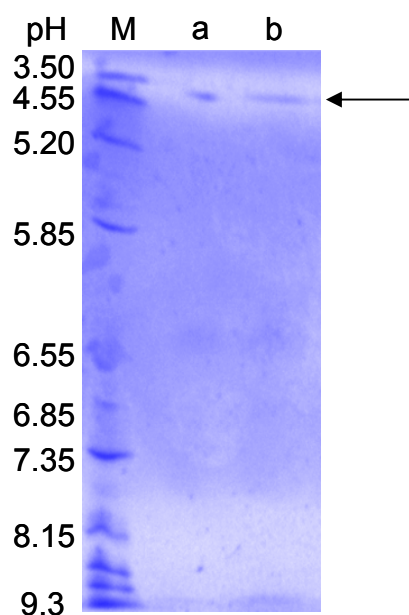

Figure 3.29: Determination of pI of purified laccase isoenzymes from *C. polyzona*. a, peak 1 (Mono Q elution); b, peak 2 (Mono Q elution).

As shown in Figure 3.30, a single band was observed for the peak pool 1 (Lac I) as well as peak 2 (Lac II) eluted from AEX on the native PAGE. The small peak containing laccase activity from the wash step of HIC migrated differently compared to Lac I and Lac II, which proves to be another laccase isozyme. This suggested the presence of a third laccase isozyme. Non-denaturing gel showed that the three isozymes migrated differently and therefore had different charge properties. This proved that there are at least three different isozymes of laccase produced from *C. polyzona* under the standard medium conditions.

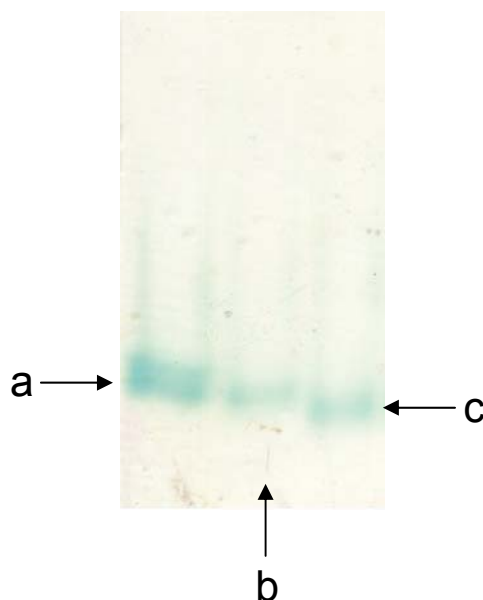

Figure 3.30: Native PAGE staining with 2.5 mM ABTS (a) HIC (wash); (b) peak 1 (Mono Q elution); (c) peak 2 (Mono Q elution).

3.4.3 Laccase Activity with respect to pH and Temperature

The influence of pH on laccase activity varied with the substrate. The optimal pH of purified Lac I and Lac II were determined using ABTS, DMP and SYN as substrates separately. The results are shown in Figure 3.31. The optimal pH values of both enzymes were 2.8 and 3.0 determined under the oxidation of ABTS and DMP, respectively. The pH optimum for SYN was 5.0 and the substrate could not be oxidized when pH was below 4.0.

The effect of temperature on the activity of both isoforms was investigated at various temperatures (20°C - 90°C). It was found that activity of the laccases increased with the rising temperature and reached their maximum level at 80°C and 70°C respectively for Lac I and Lac II (Figure 3.31d).

Both isoenzymes were stable at neutral pH such as phosphate buffer (pH 7.0) at low temperature. However, at an alkaline pH of 9.0, Lac I lost 10% of its activity within

1 hour at room temperature (25°C), and 80% at 40°C over the same time period. An acidic pH of 3.0 caused partial inactivation of both laccases within 1 hour. After storage at pH 3.0 in room temperature for 1 hour, the residual activity of Lac I became 70%. Therefore, isoforms were kept in sodium phosphate buffer at pH 7.0 and stored at -20°C for further characterization studies.

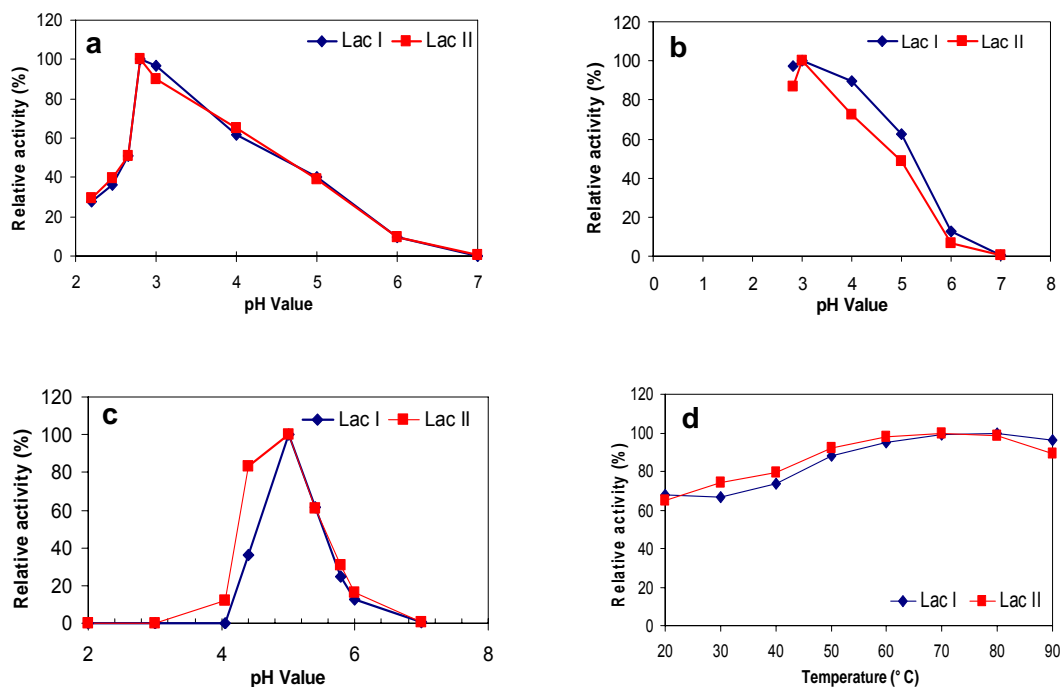

Figure 3.31: Dependence of isoenzymes from *C. polyzona* on pH and temperature. Laccase activity at different pHs using substrates: (a) ABTS; (b) DMP; (c) SYN. (d) Laccase activity at different temperatures. All the assays were done in triplicate for all samples and results are expressed as the mean values within a standard deviation of less than 5%.

3.4.4 Catalytic Properties

In order to further investigate the catalytic properties of Lac I and Lac II, the kinetic parameters (K_m and k_{cat}) were determined with ABTS, DMP and SYN at their optimal pH. Table 3.9 presents the kinetic properties of the two isoforms. Purified laccases showed notable differences in their catalytic efficiencies (k_{cat}/K_m) when substrates varied. Among the selected substrates, the highest enzyme affinity and efficiency of the oxidation reaction was obtained with ABTS for both isozymes. Moreover, the K_m values of Lac I were generally lower than those of Lac II, indicating that Lac I has slightly higher affinity toward the substrates.

Table 3.9: Kinetic properties of laccases of selected substrates.

Substrate	Lac I				Lac II			
	K_m (μM)	V_{max} ($\mu\text{M}\cdot\text{min}^{-1}$)	k_{cat}	k_{cat}/K_m ($\mu\text{M}^{-1}\cdot\text{min}^{-1}$)	K_m (μM)	V_{max} ($\mu\text{M}\cdot\text{min}^{-1}$)	k_{cat}	k_{cat}/K_m ($\mu\text{M}^{-1}\cdot\text{min}^{-1}$)
ABTS	10.96±1.04	608.70±13.70	1.1x10 ⁵	1.0x10 ⁴	12.22±1.80	504.8±18.58	2.3x10 ⁵	1.9x10 ⁴
DMP	291.1±29.64	565.4±19.04	1.0x10 ⁵	3.4x10 ²	356.8±46.06	(3±0.13)x10 ³	1.4x10 ⁶	3.9x10 ³
SYN	10.31±1.31	308.8±13.34	7.0x10 ⁴	6.8x10 ³	15.96±1.10	(1.49±0.015)x10 ³	1.7x10 ⁵	1.0x10 ⁴

3.4.5 Substrate Specificity and Inhibition Pattern of *C. polyzona* Laccases

The substrate specificity of *C. polyzona* laccases was qualitatively studied by changes in the adsorption spectra of reaction mixtures. Both isoenzymes had broad substrate specificities. As shown in Table 3.10, the typical substrates, such as ABTS, guaiacol, DMP, SYN, ferulic acid and pyrogallol, were oxidized by laccases. No activity was observed when incubated with either tyrosine or veratryl alcohol.

Table 3.10: Substrate specificity of *C. polyzona* laccase

Compound	Wavelength*
ABTS	414nm
2- methoxyphenol (guaiacol)	470nm
DMP	469nm
SYN	425nm
Ferulic acid	287nm
Vanillin	230nm
Pyrogallol	450nm
3,4-Dimethoxybenzoic(veratryl) alcohol	NC
L-Tyrosine	NC

*NC: no changes in the reaction; * New absorption maxima observed after incubation with the substrate with the laccases.*

The effect of several laccase inhibitors was determined with ABTS as substrate in 100 mM sodium tartrate buffer at pH 3.0. As shown in Table 3.11, low concentration of sodium azide inhibited laccases completely, while other inhibitors, such as L-cysteine and SDS required at least 10 times higher than the concentration of sodium azide for complete inhibition. Complete inhibition only took place when concentration of DTT was higher than 5mM. EDTA, KCl and KI were potent inhibitors as well.

Table 3.11: Effect of various inhibitors on oxidation of ABTS by purified *C. polyzona* laccases

Compound	Concentration (mM)	Inhibition (%)	
		Lac I	Lac II
EDTA	5	37	34
	0.5	30	28
L- Cysteine	5	100	100
	0.5	42	6
Dithiothreitol (DTT)	5	56	57
	0.5	39	28
SDS	5	95	100
	0.5	22	4
Sodium azide	0.5	100	100
KCl	5	26	15
KI	5	38	13

3.4.6 MALDI-MS Analyses

As can be seen from the data, biochemical and physico-chemical properties of both enzymes were quite similar although not the same. Further MALDI analysis of digests of laccase isoforms Lac I and Lac II within the m/z range of 1200-4000 supported the suggestion that these two isoenzymes were highly similar (Figure 3.32). Six peaks could be identified as main peaks in both spectra. The spectra are very similar except for several peaks difference in the spectrum of digest products of Lac I and II as indicated in red arrows.

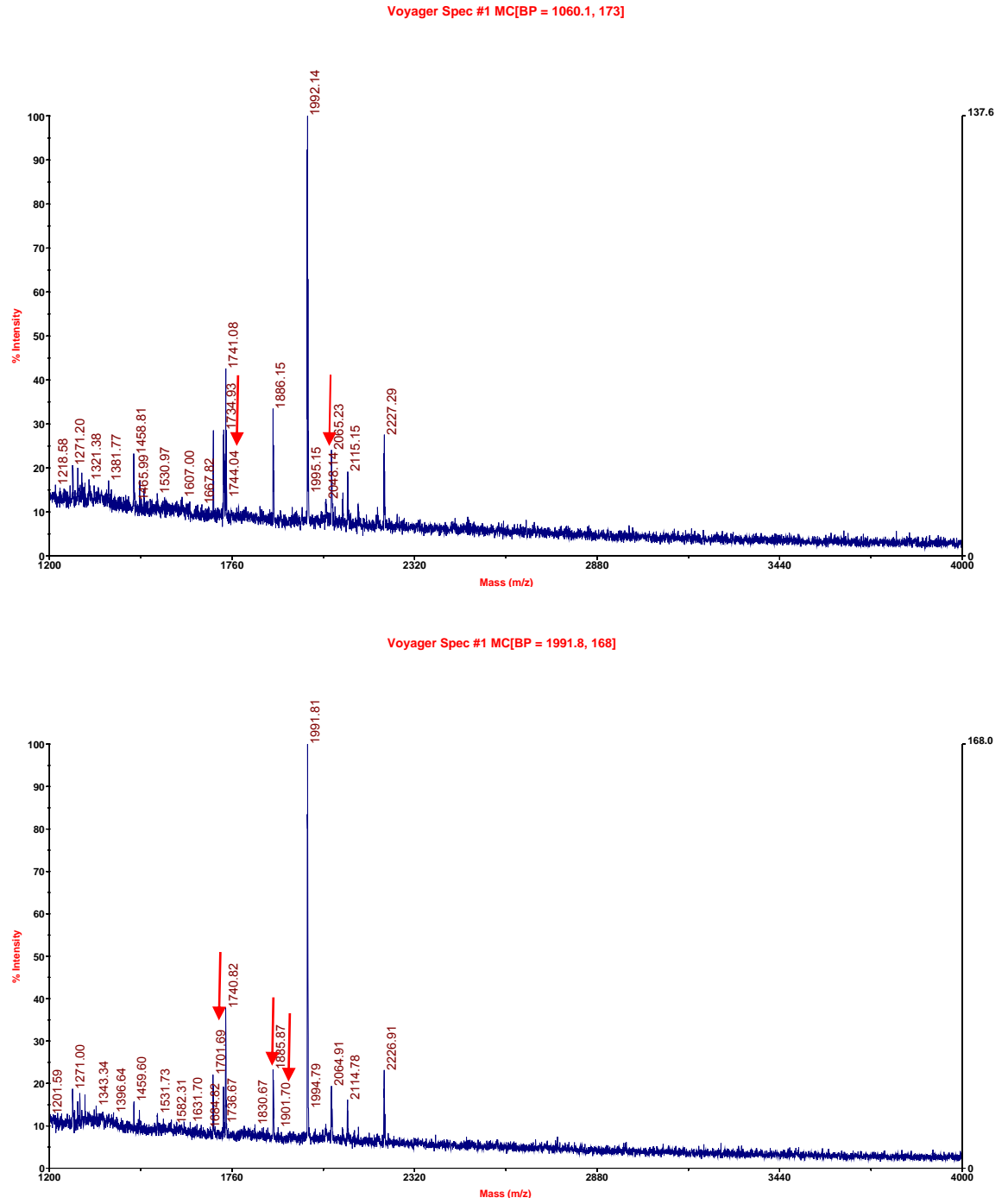

Figure 3.32: MALDI-MS spectra analysis of tryptic digestion products of Lac I and Lac II.

3.5 Decolourisation of Textile Dye by Whole Culture of *C. polyzona* and by Purified Laccase (Lac I)

3.5.1 Single Dye Wastewater Decolourisation by Purified Laccase

The purified laccase (Lac I) alone or in combination with a mediator was used to evaluate the oxidation of various selected single dyes. Two levels of ABTS and VA were used as laccase mediator. In addition, the effect of MnSO₄ or/and H₂O₂ on decolourisation of anthraquinone and azo dyes were also investigated.

Table 3.12: Comparison of decolourisation rate of selected single dyes using purified Lac I.

Dye	Reaction mixture	% decolourisation after		
		1 hour	2 hour	24 hour
Acid Blue 62	Lac	77.7	77.9	78.9
	Lac + 2 μ M H ₂ O ₂	79.6	79.7	80.5
	Lac + 4 μ M MnSO ₄	79.6	79.7	80.4
	Lac + 1 μ M H ₂ O ₂ + 2 μ M MnSO ₄	79.4	79.6	80.2
	Lac + 2.5mM ABTS	80.9	81.1	81.7
	Lac + 0.25mM ABTS	78.6	78.7	79.4
	Lac + 2.5mM VA	73.8	74.3	71.6
	Lac + 1.25mM VA	68.2	74.0	71.9
		1 hour	2 hour	24 hour
Acid Black 194	Lac	13.3	20.3	56.4
	Lac + 2 μ M H ₂ O ₂	8.0	14.2	49.7
	Lac + 4 μ M MnSO ₄	17.4	26.5	65.4
	Lac + 1 μ M H ₂ O ₂ + 2 μ M MnSO ₄	2.3	4.8	55.7
	Lac + 2.5 mM ABTS	16.0	17.6	56.9
	Lac + 0.25mM ABTS	3.00	10.0	46.3
	Lac + 2.5mM VA	29.9	35.1	60.6
	Lac + 1.25mM VA	27.3	31.9	62.6

(The table continues to the next page)

Dye	Reaction mixture	% decolourisation after		
		1 hour	2 hour	24 hour
Reactive Black	Lac	n.d	n.d	n.d
	Lac + 2 μ M H ₂ O ₂	-0.1	0.9	12.5
	Lac + 4 μ M MnSO ₄	-0.5	-0.5	-2.3
	Lac + 1 μ M H ₂ O ₂ + 2 μ M MnSO ₄	-0.2	0.1	-1.3
	Lac + 2.5mM ABTS	0.3	1.6	3.6
	Lac + 0.25mM ABTS	n.d	1.0	2.0
	Lac + 2.5mM VA	55.3	64.7	67.8
	Lac + 1.25mM VA	-2.3	-2.0	25.7
		1 hour	24 hour	48 hour
Direct Blue 71	Lac	0.3	0.6	0.6
	Lac + 2 μ M H ₂ O ₂	0.2	0.6	0.6
	Lac + 4 μ M MnSO ₄	-0.2	0.2	0.3
	Lac + 1 μ M H ₂ O ₂ + 2 μ M MnSO ₄	-0.1	0.3	0.5
	Lac + 2.5mM ABTS	-0.9	1.8	4.5
	Lac + 0.25mM ABTS	0.2	0.6	0.6
	Lac + 2.5mM VA	44.6	77.2	79.2
	Lac + 1.25mM VA	0.5	2.6	4.7

*n.d: not detectable

Table 3.12 shows that Lac I alone was able to decolourise all the dyes tested but the process was not sufficient and longer time treatment was required.

The anthraquinonic dye acid blue 62 (Abu 62) proved to be easily decolourised among these four commercial single textile dyes. Abu 62 decolourised rapidly with purified laccase alone, leading to 77.7% decolourisation after 1 hour incubation time. The addition of H₂O₂, MnSO₄ and ABTS to the reaction mixtures enhanced decolourisation to some extent. However, the involvement of VA resulted in decrease in %decolourisation.

The salt concentration and pH for acid black 194 (AB 194) were kept the same as in Abu 62. Lac I decolourised acid black 194 less efficiently compared to ABu 62, with an initial decolourisation of 13.3% after 1 hour. The percentage of decolourisation increased gradually to 20.4% after 2 hours, followed by 56.4% after 24 hours (Table 3.12). The addition of MnSO_4 to the reaction mixtures slightly enhanced decolourisation to some extent. The involvement of H_2O_2 showed inhibitory effect of AB194 decolourisation after 1 hr treatment. ABTS and VA were found to improve laccase performance in removal of AB 194. The results demonstrated that the combination of laccase and VA gave better results than the combination of laccase and ABTS. The addition of 2.5 mM mediator VA resulted in faster initial decolourisation rate compared to the reaction mixture supplemented by 1.25 mM mediator VA.

Reactive black 5 (RB5) and direct blue 71 (DB 71) were resistant to oxidation by the treatment compared to Abu 62 and AB 194. Almost no decolourisation was detected in Abu 62 and AB 194 with purified laccase alone. The addition of H_2O_2 or/and MnSO_4 did not remove the colours of these two dyes except that RB5 showed 12.5% decolourisation with 2 μM H_2O_2 after 24 hours. However, this decolourisation was not caused by the enzymatic mechanism rather than the reaction between H_2O_2 and the dyes. On the other hand, there was an increase in absorbance for RB5 and DB 71 with H_2O_2 or/and MnSO_4 respectively.

There was a slightly enhancement in dye decolourisation when 2.5 mM ABT was introduced into these two single dye solutions compared to laccase alone, whereas the mediator VA showed remarkable increase in decolourisation of diazo dye RB5 and azo dye DB71. The combination of Lac I and 2.5 mM VA decolourised RB5 and DB71 by 55.3% and 44.6% within 1 hour respectively.

3.5.2 Model Dye Wastewater Decolourisation by Purified Laccase

Real textile industry effluents often contain several dyes as well as salt in high pH. In this work, three single dyes were mixed in order to evaluate the applicability of enzyme catalysed degradation processes to a real situation and provide background information for commercial laccase catalysed degradation of textile effluent.

Purified laccase (Lac I, 100 U/l) was applied to four model dye wastewater samples, including acid dye bath for wool, acid dye bath for leather, reactive dye bath for cotton and direct dye bath for cotton to investigate its ability on mixed dye decolourisation.

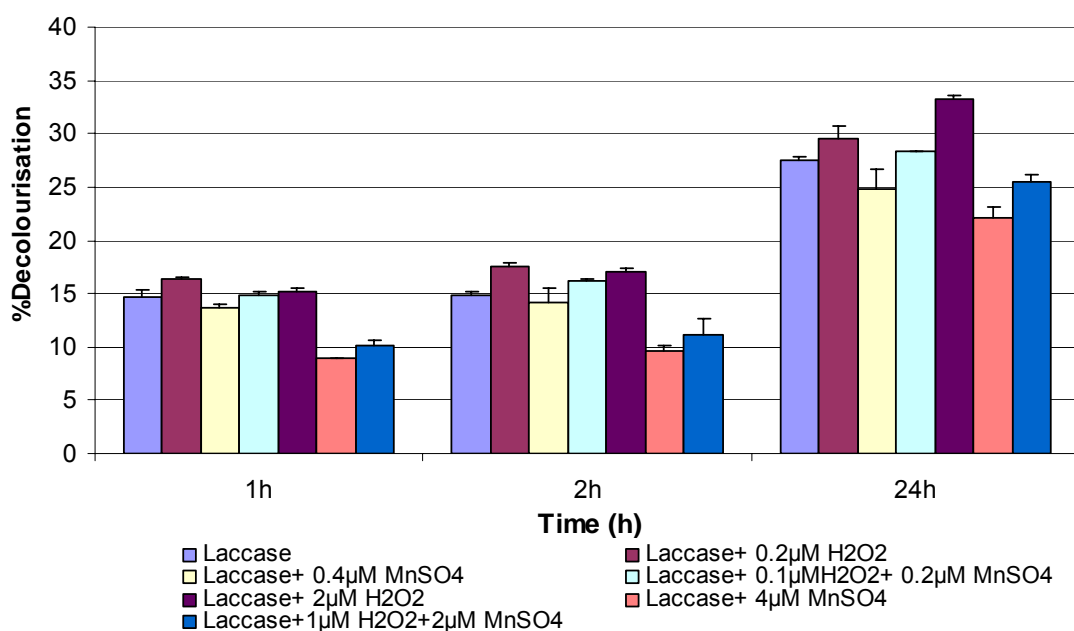

Figure 3.33: Effect of Mn^{2+} and H_2O_2 on purified laccase-mediated acid dye bath wastewater (wool) decolourisation (Values shown represent average of duplicate samples, error bars represent standard deviation).

In the case of acid dye bath (wool) (Figure 3.33), the addition of H_2O_2 slightly enhanced dye decolourisation. When two concentrations of H_2O_2 were employed in the acid dye bath (wool), decolourisation rate of 33% and 30% was obtained in the

2 μM H_2O_2 and 0.2 μM H_2O_2 supplemented wells respectively after 24 hours incubation period.

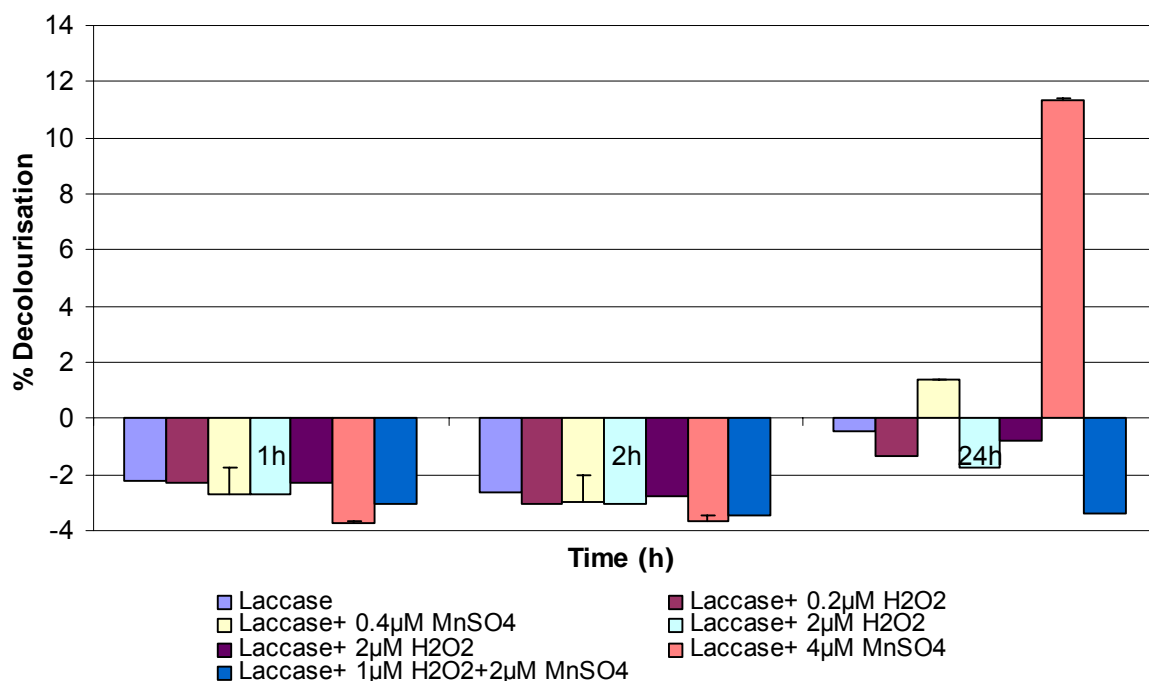

Figure 3.34: Effect of Mn^{2+} and H_2O_2 on purified laccase-mediated acid dye bath (leather) wastewater decolourisation (Values shown represent average of duplicate samples, error bars represent standard deviation).

When purified laccase (Lac I, 100 U/l) was applied to acid dye bath (leather), there was no decolourisation in most of the dye mixtures. The negative values of %decolourisation indicated that there was no colour removal but colour enhancement. However, in the 0.4 μM and 4 μM MnSO_4 supplemented wells, 1% and 11% decolouration was achieved respectively after 24 hours. There was no decolourisation observed after 24 hours incubation with 100 U/l purified laccase alone or together with H_2O_2 and MnSO_4 .

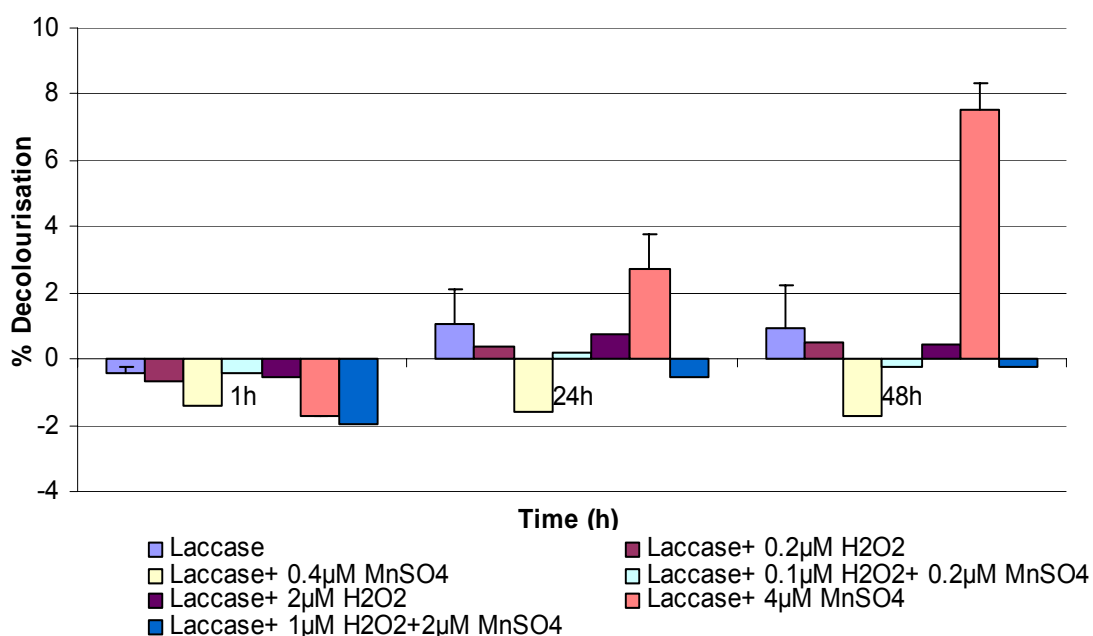

Figure 3.35: Effect of Mn^{2+} and H_2O_2 on purified laccase-mediated direct dye bath (cotton) wastewater decolourisation (Values shown represent average of duplicate samples, error bars represent standard deviation).

Figure 3.35 shows that purified laccase decolourised direct dye bath (cotton) under various conditions, but the %decolourisation was low. The addition of $0.4 \mu M$ $MnSO_4$ had negative effect on direct dye decolourisation. On the other hand, when $4 \mu M$ $MnSO_4$ was added into the wells, decolourisation of 2% and 7% was achieved after 24 hours and 48 hours incubation period.

It was found that purified laccase decolourized acid dye bath (wool) more efficiently than acid dye bath (leather) and direct dye bath (cotton). As for reactive dye bath (cotton) decolourisation, after 48 hours incubation, there was no decolourisation detected in the mixtures at all.

3.5.3 Model dye wastewater decolourisation by whole culture

Figure 3.36: Effect of Mn^{2+} and H_2O_2 on culture liquid (CL)-mediated acid dye bath wastewater (wool) decolourisation (Values shown represent average of duplicate samples, error bars represent standard deviation).

Culture broth from shaken flask fermentation of *C. polyzona* was harvested on the 15th day when the highest laccase activity was achieved. Culture liquid with laccase activity of 100 U/l was prepared and used to treat model dyes to compare the purified laccase for dye decolourisation.

In the case of acid dye bath (wool) (see Figure 3.36), the addition of H_2O_2 slightly enhanced dye decolourisation. When 0.2 μM and 2 μM H_2O_2 were added to the in reaction mixtures, 30% and 36% decolourisation was achieved respectively after 24 hours incubation period.

The treatment of acid dye bath for wool and leather resulted in higher decolourisation with whole culture compared to purified laccase alone, particularly in the case of acid

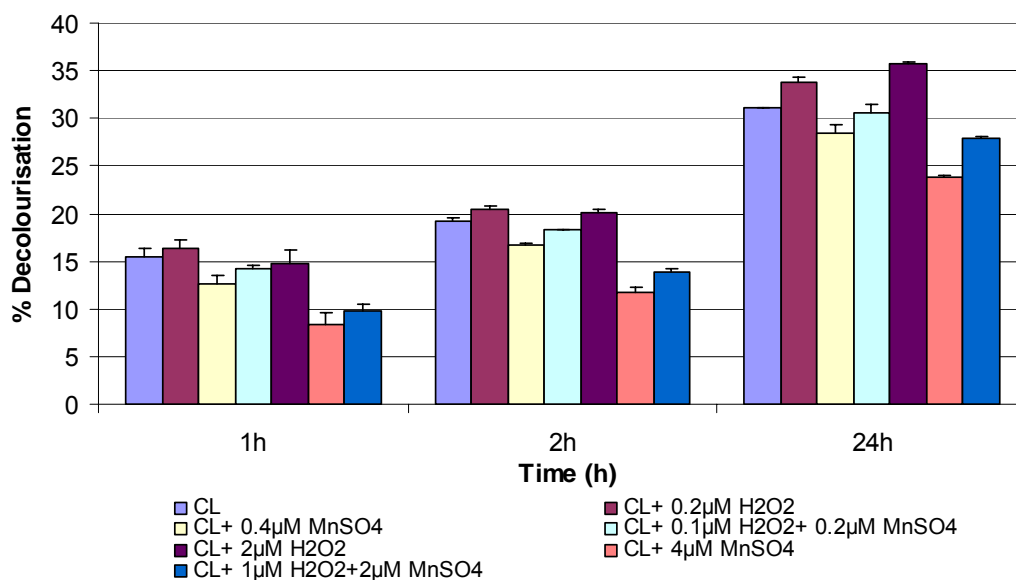
dye bath for leather (Figure 3.37). The addition of culture liquid led to 18% decolourisation after 24 hours incubation period in the wells supplemented with MnSO_4 and H_2O_2 , whereas no decolourisation was found using purified laccase. The results indicate the presence of other oxidative enzymes, such as LiP and MnP, which could contribute to the dye decolourisation.

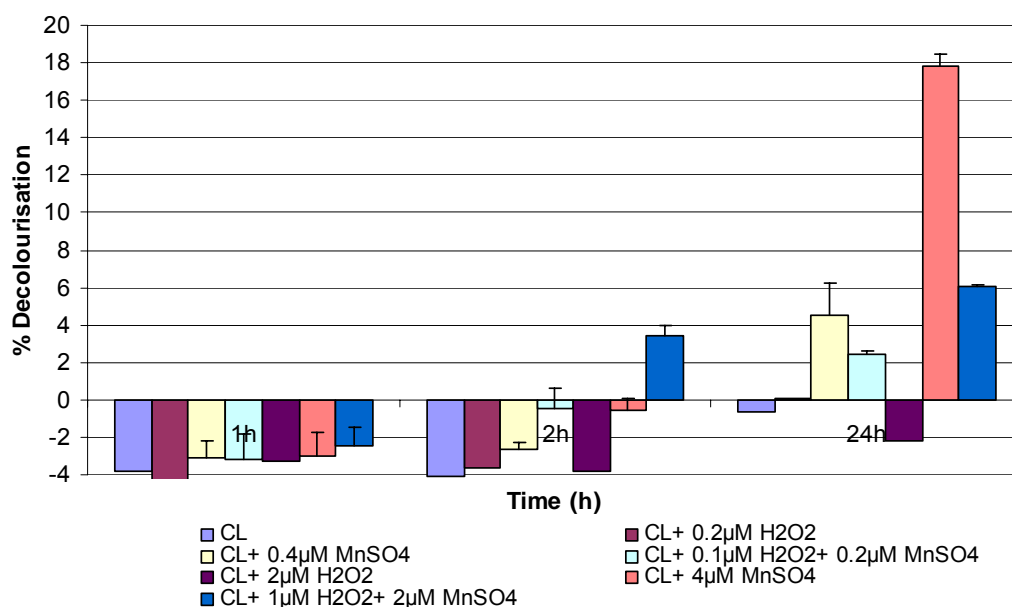

Figure 3.37: Effect of Mn^{2+} and H_2O_2 on culture liquid (CL)-mediated acid dye bath (leather) wastewater decolourisation (Values shown represent average of duplicate samples, error bars represent standard deviation).

When culture liquid was applied to the acid dye bath (leather), no dye decolourisation occurred in most of the reaction mixtures except for the 0.4 μM and 4 μM MnSO_4 supplemented wells, where 4% and 8% decolouration was achieved respectively. The negative results shown in the figure indicated that there was no dye decolourisation in the reaction mixture. Instead, there was increase in the absorbance at 410, 520, 620 nm for mixed dyes. The addition of H_2O_2 together with MnSO_4 resulted in 2% and 6% decolourisation separately after 1 hour and 24 hours incubation.

3.5.4 Effect of Mediator on Reactive and Direct Acid Dye Decolourisation

Due to the poor performance in reactive dye and direct acid dye bath decolourisation with purified laccase and whole culture, mediator VA was introduced to the dye decolourisation experiments. Two levels of VA were applied in the reactive dye bath wastewater (cotton) and direct dye bath wastewater (cotton) separately in order to investigate the effect of laccase-mediator system on the reactive and direct model dyes. The culture broth from *C. polyzona* was prepared to contain laccase activity of 100 U/l, the same as purified laccase.

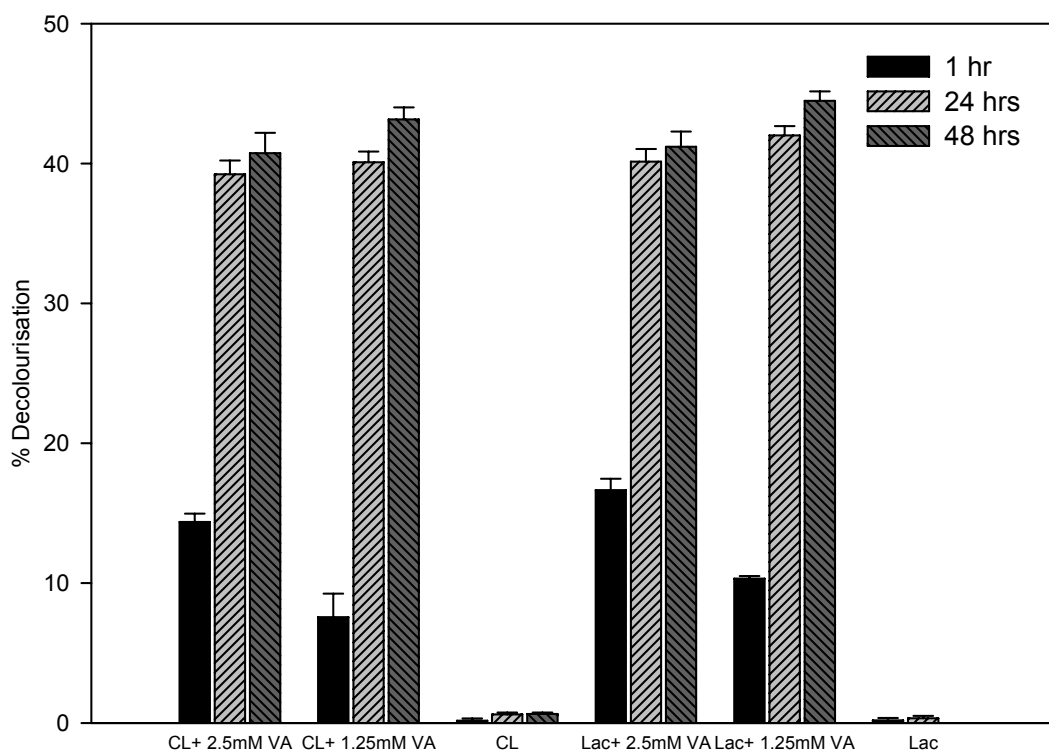

Figure 3.38: Effect of violuric acid (VA) on purified laccase (Lac I) and culture liquid (CL)-mediated reactive dye bath wastewater (cotton) decolourisation (Values shown represent average of triplicate samples, error bars represent standard deviation).

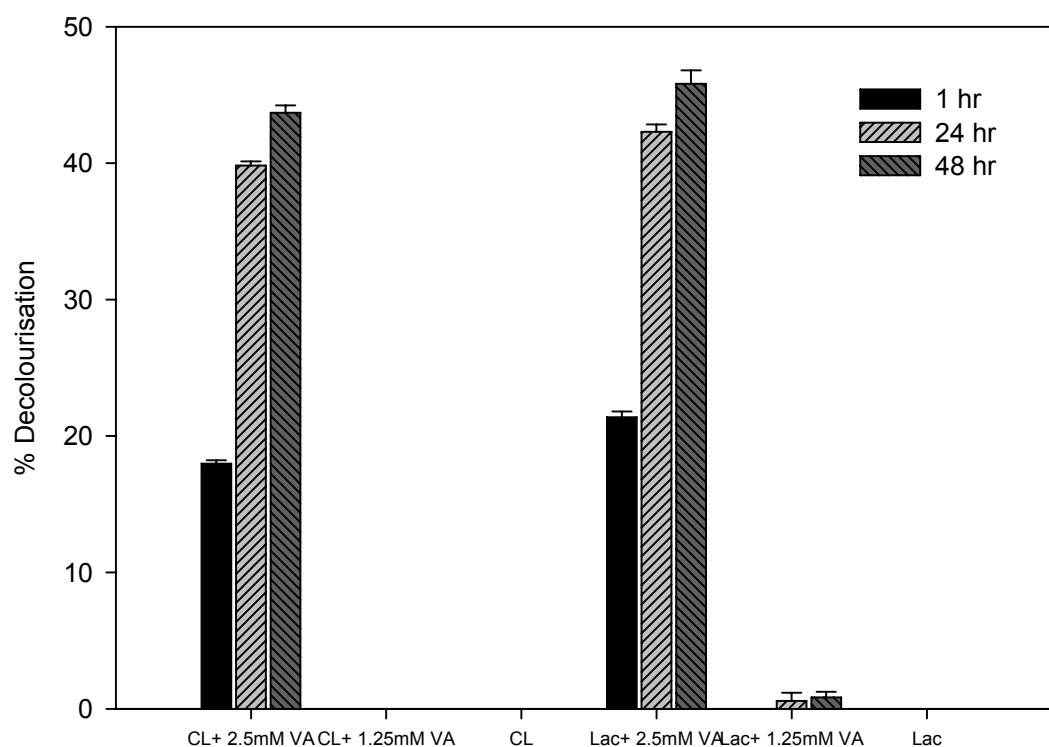

Figure 3.39: Effect of violuric acid (VA) on purified laccase (Lac I) and culture liquid (CL)-mediated direct dye bath wastewater (cotton) decolourisation (Values shown represent average of triplicate samples, error bars represent standard deviation).

It was found in Figures 3.38 and 3.39 that no decolourisation was achieved in the control, whereas the decolourisation of reactive and direct dye baths only occurred in the presence of mediator VA.

VA imposed positive effect on decolourisation of these two dyes after one hour and increased the decolourisation to 40-50% after 48 hours treatment. In the case of reactive model dye decolourisation, higher concentration of 2.5 mM VA resulted in higher decolourisation rate after 1h in both purified laccase and whole culture treatments, whereas 1.25 mM VA showed slightly higher decolourisation than that

achieved in 2.5 mM VA supplemented wells in 24 hours and 48 hours respectively. As for direct model dye decolourisation, decolourisation occurred with the addition of 2.5 mM VA. Figures 3.38 and 3.39 showed that there is no difference between the purified laccase and the culture liquid mediated decolourisation. This suggests that VA reacts only with laccase rather than other enzymes.

3.5.5 Optimization of Reactive Black 5 Decolourisation by Response Surface Methodology

Purified laccase from *C. polyzona* was found to decolourise single dyes and mixed dyes that simulated effluents from textile industry in previous results sections. The reactive black 5 is widely used for textile industry but resistant to decolourisation. It was shown that purified laccase from *C. polyzona* was unable to decolorize RB5. However, in the presence of VA, the dye was transformed from blue colour to reddish pink and subsequently to colorless. The previous studies indicated that the laccase-mediator systems were effective with respect to degrading RB5, however, the laccase activity is inhibited when the concentration of mediator is above a certain level (Murugesan *et al.*, 2007). Therefore, optimisation of VA concentration is essential for the successful decolourisation. To explore the effect of selected variables, including [laccase activity], [VA], pH, Box-Behnken experimental design was applied using Minitab 15. The biodegradation of RB5 from the design at each experimental point is summarized in Table 3.13 along with experimental and theoretical observed values.

Table 3.13: Experimental design and response (observed and predicted) of the Box-Behnken.

Run	pH	VA (mM)	Laccase activity (U/l)	% Decolourisation	
				Observed Value	Predicted Value
1	5	2.50	200	70.59	72.52
2	7	0.00	300	-1.75	-0.36
3	9	0.00	200	-1.30	-4.62
4	5	2.50	200	67.94	72.52
5	5	0.00	200	0.86	4.90
6	5	1.25	300	57.71	50.68
7	9	2.50	200	29.78	24.39
8	9	1.25	100	0.59	7.51
9	7	1.25	200	5.99	5.64
10	9	1.25	100	0.57	7.51
11	5	0.00	200	0.69	4.90
12	9	1.25	300	7.14	9.64
13	7	1.25	200	5.56	5.64
14	7	0.00	100	-2.10	-6.82
15	7	0.00	300	-4.58	-0.36
16	5	1.25	100	23.27	24.11
17	7	2.50	100	33.28	33.60
18	7	1.25	200	4.58	5.64
19	7	2.50	100	39.53	33.60
20	7	1.25	200	5.93	5.64
21	7	1.25	200	6.08	5.64
22	7	1.25	200	5.69	5.64
23	7	2.50	300	52.83	55.85
24	5	1.25	300	57.50	50.68
25	7	2.50	300	51.52	55.85
26	9	2.50	200	27.23	24.39
27	7	0.00	100	-4.19	-6.82
28	9	0.00	200	-1.43	-4.62
29	5	1.25	100	25.83	24.11
30	9	1.25	300	11.24	9.64

The statistical analysis of Box-Behnken experimental results were carried out using Minitab15. The statistical analysis employed Fisher's 'F' test and Student's *t*-test. The results of analysis of variance (ANOVA) for percentage decolourisation show that fitted second order response surface model is highly significant with F -test=82.25 ($p=0.000$) as shown in Table 3.14. The student's *t*-test is used to determine the significance of the regression coefficients of the variables. A p value is the indicator of the significance of the test. If p value is below 0.05, it indicates that regression is statistically significant ($p < 0.05$) at 95% of confidence level. Generally, the larger the magnitude of t and smaller value of p , more significant is the corresponding coefficient term (Mohana *et al.*, 2008). The regression coefficients, t and p values for all the linear, quadratic and interaction effects of the variables are given in Table 3.15.

Table 3.14: ANOVA results for RB5 decolourisation, quadratic response surface model fitting.

Source	Degree of freedom (DF)	Sum of squares (SS)	Mean of squares (MS)	F	P
Model	9	16092.5	1788.06	82.25	0.000
Linear	3	13482.7	4494.22	206.74	0.000
Square	3	1440.8	480.27	22.09	0.000
Interaction	3	1169.0	389.68	17.93	0.000
Residual Error	20	434.8	21.74		
Lack-of-fit	3	388.1	129.38	47.17	0.000
Pure Error	17	46.6	2.74		
Total	29				

Coefficient of correlation (R^2) = 97.4%; Coefficient of determination (adj R^2) =96.2%

Table 3.15: Regression coefficient of the model

Term	Coef	SE Coef	<i>t</i>	<i>p</i>
Constant	5.637	1.903	2.962	0.008
X1	-14.410	1.166	-12.363	0.000
X2	24.256	1.166	20.724	0.000
X3	7.176	1.166	6.156	0.000
X1·X1	10.536	1.716	6.141	0.000
X2·X2	8.122	1.716	4.734	0.000
X3·X3	6.809	1.716	3.969	0.001
X1·X2	-9.655	1.648	-5.857	0.000
X1·X3	-6.111	1.648	-3.707	0.001
X2·X3	3.947	1.648	2.394	0.230

The fitted second order response surface model specified by Eq. (1) for % decolourisation in coded process variables is

$$Y = 5.64 - 14.41X_1 + 24.16X_2 + 7.18X_3 + 10.54X_1^2 + 8.12X_2^2 + 6.81X_3^2 - 9.66X_1X_2 - 6.11X_1X_3 + 3.95X_2X_3 \quad (\text{Eq. 2})$$

Where Y is the predicted response, X_1 , X_2 and X_3 are process variables.

The coefficient of determination (R^2) value provides a measure of how much variability in the observed response values can be explained by the experimental factors and their interactions. The regression coefficient of determination (R^2) of 97.4% proves the equation is highly reliable and can be used for predicting response

at any combination of three variables in experimental range. The decolourisation percentage at specified combination of three variables can be predicted by substituting corresponding coded values in Eq. (2)

The 3D response surfaces were generated using STATISTICA 7.0 (StatSoft. Inc., Tulsa, USA), which are the graphical representation of the regression equations. They demonstrate the effect of any two variables among laccase activity, pH and VA concentration on %decolourisation, when the third variable is kept constant. The usage of response surface is to investigate the optimal value of each variable, which will lead to the maximum dye removal. Apart from the linear effect of variables in dye decolourisation process, the second order RSM indicates their quadratic and interaction effects respectively. The coefficient for the linear effect of enzyme ($p=0.000$), pH ($p=0.000$) and VA concentration ($p=0.000$) were highly significant, so were the quadratic effects of these three parameters. The interaction was statistically significant between pH and enzyme ($p=0.000$), as well as between pH and VA ($p=0.000$).

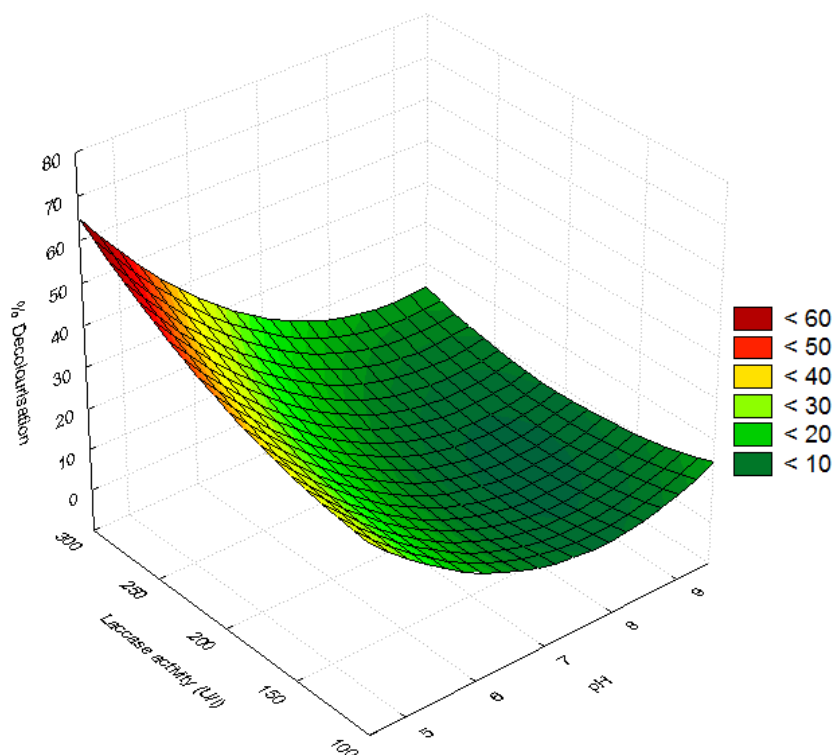

Figure 3.40: Surface response for RB5 decolourisation as a function of laccase activity and pH.

Figure 3.40 demonstrates the maximum percentage of dye decolourisation against interaction between laccase activity and pH. Maximum RB5 decolourisation was achieved when high laccase activity and low pH were applied. Decolourisation decreased with increase in pH even in the presence of high laccase activity (300 U/l), which might be due to the loss of laccase activity when it was incubated at high pH. This observation was in agreement with the previous findings with respect of the pH stability of purified laccase from *C. polyzona*. The purified laccase from *C. polyzona* exhibited low enzyme activity when the reaction system's pH increases.

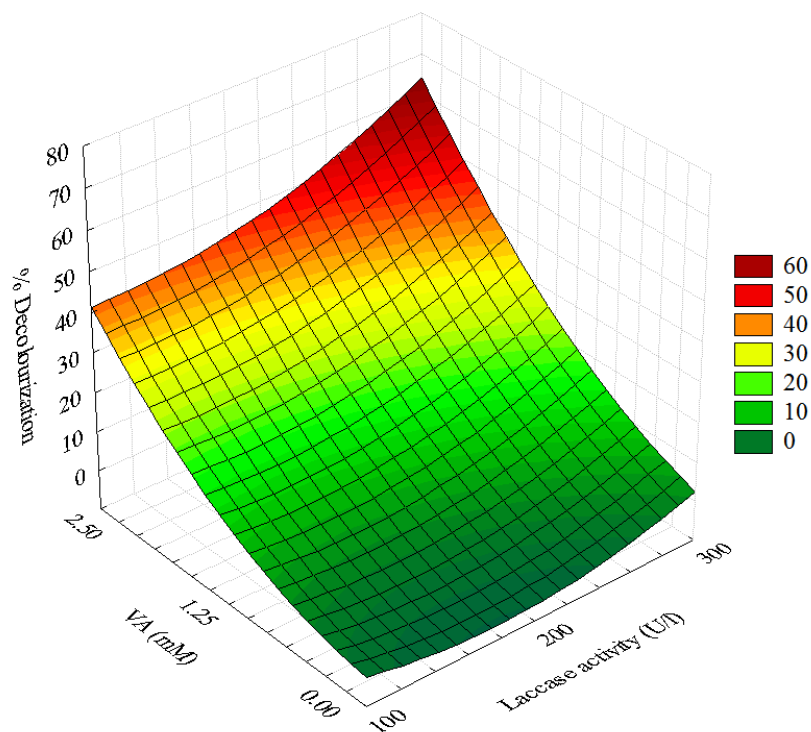

Figure 3.41: Surface response for RB5 decolourisation as a function of laccase activity and [VA].

Figure 3.41 shows the effect of interaction of laccase activity and VA concentration on RB 5 decolourisation. The 3D response surface plot indicated that the percentage of decolourisation increased when higher levels of laccase activity and VA were applied. This agreed well with the results carried out in section 3.5.1. As shown in Figure 3.41, the decolourisation of RB 5 almost reached 70% when 300 U/l laccase activity and 2.50 mM VA were added to the wells.

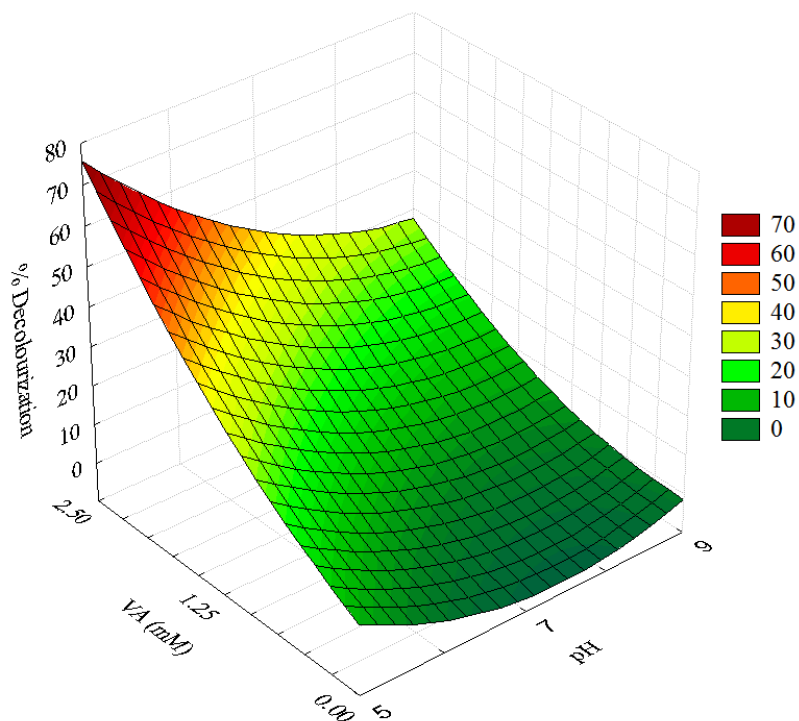

Figure 3.42: Surface response for RB5 decolourisation as a function of pH and [VA].

Figure 3.42 shows the 3D response surface plot of interaction between varying the concentration of VA and pH on RB5 decolourisation. It demonstrated that more acidic condition (pH 5.0) was preferred in the RB5 decolourisation by the laccase from *C. polyzona*. The decolourisation did not occur without VA and was remarkably improved when VA was added, reaching 72.5% within one hour. When VA was introduced, there was 55.9% and 24.4% decolourisation even though the pH of the reaction system was 7.0 and 9.0 respectively, which further proved the advantage of laccase-mediator system.

The investigation has revealed that the optimum concentrations of Lac I, VA and pH were 300 U/l, 5.0 and 2.5 mM respectively.

CHAPTER 4: DISCUSSION

4.1 Strain Screening

4.1.1 Medium Optimisation

The objective of this project was to enhance laccase production by selected white rot fungi. Three different white rot fungi *P. sanguineus*, *P. ostreatus* and *C. polyzona* were chosen and compared for laccase production in liquid media. Statistical methods have proved to be powerful and efficient tools for media optimisation in fermentation technology and bioprocess. Therefore, we applied Plackett–Burman experimental design to optimise medium compositions for laccase production by the mentioned white rot fungi. Different concentrations of the medium components, such as potato dextrose, CuSO₄, yeast extract, elicitor (MO), lactose, glucose, and initial pH were chosen to investigate their effect on laccase production. These factors were considered to be important for laccase production by white rot fungi based on previous studies (Sandhu and Arora, 1984, Petruccioli *et al.*, 1999, Tekere *et al.*, 2001, Palmieri *et al.*, 2003, Jaouani *et al.*, 2004). For example, the culture pH was controlled throughout the fermentations of the three strains. The best condition for each strain fell with the pH range of 4-6 for laccase production by these white rot fungi (Nyanhongo *et al.*, 2002). In the case of *P. sanguineus*, limited nitrogen level resulted in highest laccase production, whereas high nitrogen concentration is necessary for laccase production by *P. ostreatus* and *C. polyzona*. This further confirms the importance of nitrogen concentration (yeast extract in this case) in fungal laccase production. The results obtained from *P. ostreatus* and *C. polyzona* confirms that high nitrogen levels are preferred in high laccase activity for fungal laccases (Fu *et al.*, 1997, Gianfreda *et al.*, 1999, Quarantino *et al.*, 2008). However, some authors have found that laccase activity increases under nitrogen-limiting conditions, such as *P. sanguineus* (Pointing *et al.*, 2000). Our results are in agreement with previous findings. Therefore, nitrogen concentration is a controversial subject and it highly depends on different fungi strains.

4.1.2 Effect of MO and Ferulic Acid

Variety of oligosaccharides derived from alginate and locust bean gum have been reported to act as elicitors in liquid cultures of filamentous fungi. These elicitors have initiated enhancement in the levels of secondary metabolites. MO is found to play positive effect in enhancement of fungal metabolites in different fungal cultures (Petruccioli *et al.*, 1999, Radman *et al.*, 2003). Given that laccase is a secondary metabolite produced by white rot fungi, it was reasonable to evaluate the possibility of elicitation in laccase production by white rot fungi.

A central composition experimental design, that optimises the selected factors for maximal production, was successfully applied using MO as elicitor and ferulic acid as inducer in liquid cultures of the white rot fungi to investigate the scope for enhancing laccase production. RSM was proved to be a good method for identification of the statistically significant effects for MO and ferulic acid and their interactions in terms of laccase production.

Although MO enhanced laccase production in all the selected strains in this study, the effect was not generic. The elicitor, as a single factor, had significant effect when it was added to the liquid cultures of *P. sanguineus* ($P < 0.1$) and *P. ostreatus* ($P < 0.1$). However, in the case of *C. polyzona*, the synergistic effect of the combined MO and ferulic acid was statistically significant for the increase in laccase production ($P = 0.006$). The results suggested that MO can reduce the need for ferulic acid concentration in the liquid culture of *C. polyzona* and maintain high laccase activity. This study also showed that MO, individually and combined with ferulic acid, enhanced laccase activity in three different strains of white rot fungi. The increase in laccase production was species-specific with the highest increase in liquid culture of *P. sanguineus* followed by *P. ostreatus* and *C. polyzona*.

In plants as well as in filamentous fungi, elicitor induction of secondary metabolites is thought to be an activation of cellular defense mechanism. In the cultures of *P. chrysogenum*, MO not only enhance penicillin G levels, but also its intermediates δ -(1- α -aminoadipyl)-l-cysteinyl-d-valine (tripeptide ACV), isopenicillin N and 6-aminopenicillanic acid (Tamerler *et al.*, 2001). Other physiological changes in *P. chrysogenum* when MO is added include increases in germination rates, hyphal tip numbers and clump size as well as increase in the concentration of spores and pigmentation (Radman *et al.*, 2004). Laccases are well known for their role in lignin degradation and conidial pigmentation (Mayer, 1987). Laccase is also found to play roles in the microbial morphogenesis such as fungal spore development, fungal differentiation, and conidial pigmentation (Mayer and Staples, 2002). Laccases have been shown to be an important virulence factor in many diseases caused by fungi (Mayer and Staples, 2002). This multifunctional aspect of laccases and particularly their involvement in the defence mechanism of the fungi makes them good targets for the enhancement of production by the elicitor MO.

Aromatic compounds which are structurally related to lignin, such as ferulic acid, 2, 5-xylidine, are used to increase laccase production in fungal cultures (Yaver *et al.*, 1996, Collins and Dobson, 1997, Mansur *et al.*, 1997). These aromatic compounds are often toxic to fungi and it has been proposed that one possible function of fungal laccases is their ability to detoxify highly reactive phenols by polymerisation of toxic aromatic compounds during the degradation of lignin. Polymerised products are unable to penetrate into the cells. Therefore, laccases are involved, through a defence mechanism, in action against oxidative stress. Laccase reactions, by consuming oxygen, are expected to disfavour redox cycling of quinones with oxygen, whereas the autoxidation of hydroquinones and semiquinones leads to the generation of oxygen radicals, the corresponding laccase-catalysed oxidations yield water (Thurston, 1994). Fernandez Larrea *et al.* (FernandezLarrea and Stahl, 1996) reported that the oxidative stress in *P. anserina* that caused by the presence of aromatic compounds was typically accompanied by the induction of mRNA. ~~and~~ In another study, a dark precipitate was observed in 2, 5-xylidine induced cultures of

T. versicolor and it was suggested that it could represent a laccase-polymerized form of the aromatic compounds (Collins and Dobson, 1997). There was a similar precipitate observed in 2, 5-xylydine induced cultures of *P. sajor-caju* and in ferulic acid supplemented cultures of *P. sajor-caju* (Soden and Dobson, 2001).

Due to its capability to produce the highest laccase activity among the three strains, the strain *C. polyzona* was selected for further investigation of overproduction of laccases in liquid fermentation at different scales.

4.2 Laccase Production by *C. polyzona* in Shaken Flasks and Bioreactors

4.2.1 Effect of Inoculum Type

As *C. polyzona* was selected for further studies, it was essential to develop a practical method for large scale operation while maintaining high laccase activity. In this context, the type of inoculum was investigated. This is the first report regarding the inoculum effect on the liquid culture development and laccase production in basidiomycete fermentation.

There are different types of inoculum preparations for the production of laccases. These includes spore suspensions (Eggert *et al.*, 1996b), conidia inoculation (Kahraman and Gurdal, 2002), mycelia (Palmieri *et al.*, 2003), and homogenised mycelia (Pointing *et al.*, 2000), but there is no literature on the state of inoculum affecting laccase production by white rot fungi. This study showed that inoculum preparations affected laccase production by *C. polyzona*. When laccase production was scaled up to 2 litre stirred tank reactors, it was found that the mycelium inoculation resulted in slightly higher laccase activity and biomass (CDW) compared to conidia inoculation. It is suggested that the disparity in growth and laccase titres depending on the type of inocula may be related to the toxicity of ferulic acid and to cell damage (Dekker *et al.*, 2007). In this case, the conidia suspension scraped from

agar surface appears to be slightly more responsive to ferulic acid, resulting in lower biomass in comparison to mycelium inoculation. This might also explain that only small amounts of aromatic inducers are required in enhancement of laccases from white rot fungi.

However, conidia inoculation is recommended in industrial scaling-up procedures where time-cost considerations and ease of operation are essential.

4.2.2 Effect of Glucose Concentration

It was found that enhanced laccase production only occurred when the glucose concentration dropped below a low and critical value during *C. polyzona* fermentation in both shaken flasks and bioreactors. This suggests that laccase synthesis is inhibited when the glucose concentration is above certain level in the medium. The same phenomenon has been reported for laccase production in *T. pubescens* and *T. versicolor* respectively (Galhaup *et al.*, 2002a, Galhaup *et al.*, 2002b, Tavares *et al.*, 2005). Glucose repression is widely known in fungi and yeast and thought to be an energy-saving response (Ronne, 1995). The glucose repression has been studied in *T. pubescens* and its effects can be linked to the existence of CreA consensus sequence in the promoter region of the two laccase genes of this organism which may encode binding sites for the repressor protein CreA (Ruijter and Visser, 1997, Galhaup *et al.*, 2002a). CreA consensus sequences were also found to be detectable in the 5' noncoding region of a laccase gene from the biosidiomycete I-62, which is also subject to glucose repression (Mansur *et al.*, 1997). In liquid cultures *P. tigrinus*, the onset of laccase activity and its related transcript occurred in the early stages of fermentation when the residual glucose concentration was above 80% of its initial concentration. However, the largest increase in activity and highest abundance of lac I Pt transcripts was observed when glucose has been almost depleted (Quaratino *et al.*, 2008).

Consequently, the effect of reducing glucose concentration on laccase production was investigated in shaken flasks fermentation of *C. polyzona*. However, the decrease of initial carbon source did not result in better performance in laccase production by *C. polyzona*. Glucose concentration of 50 g/l resulted in 10-fold increase in the maximal laccase activity compared to that of 10 g/l. Therefore, glucose concentration of 50 g/l combined with other substrates (see section 3.2.2) was considered to be the optimal medium for high laccase activity for *C. polyzona*. This agrees with the findings by Galhaup and co-workers. It was reported that increasing the glucose concentration from 10 g/l to 40 g/l led to a more than 5-fold increase in laccase activity by *T. pubescens*. A further increase to 60 g/l glucose did not increase laccase further, but lower laccase activity was obtained (Galhaup *et al.*, 2002b).

4.2.3 Effect of Shear Stress

Significant biomass attachment to the fermenter vessel and ancillaries was observed during fermentation of *C. polyzona*, particularly towards the end of the fermentations. This could be caused by extracellular polysaccharides that can make the fungal biomass more adherent. Several strains of basidiomycetes, such as *T. versicolor* produced more polysaccharides towards the end of the fermentation (Thiruchelvam and Ramsay, 2007). Uncontrolled growth pattern of filamentous fungi, particularly basidiomycetes, in submerged fermentation increases broth viscosity leading to non-Newtonian rheology influences metabolic rate and product secretion. Moreover, in the *C. polyzona* fermentation, the fungal mycelia grew on impellers as well as internal surface of the fermenter causing blockages in the nutrient feeding, sampling lines and air inlet, resulting in mixing problems, mass and oxygen transfer limitation, ultimately and in sub-optimal fermentations. Therefore, efficient mixing is necessary to ensure culture homogeneity and sufficient oxygen transfer. The geometry of the reactor and the impeller design also play an important role. It was mentioned that agitation is a factor that affects laccase production. Several studies have shown that laccase production was repressed due to mechanical stress on the fungi. It was found that laccase production by *T. multicolor* decreased considerably when the fungus was

grown in a STR. The damage to the mycelia caused by shear stress was considered to contribute to the decrease (Hess *et al.*, 2002). The negative effect of agitation on laccase production has been reported also in liquid culture of *P. tigrinus* (Fenice *et al.*, 2003). In contrast, it has been reported that agitation does not play an important role in laccase production by *T. versicolor* (Tavares *et al.*, 2006). Wesenberg and co-workers mentioned high agitation is required for laccase production by white rot fungi (Wesenberg, 2003). In our study, it was difficult to sustain the optimal conditions for laccase production as *C. polyzona* fermentation proceeded. However, increases in the stirrer speed up to 475 rpm did not have an adverse effect on laccase activity.

4.2.4 Effect of Proteases

The laccase activity profile in both shaken flasks and bioreactors showed that laccase production fluctuated at later stage of *C. polyzona* fermentations, when carbon, nitrogen and sulphur limitation occurred. The decrease of laccase activity might be caused by the presence of proteases that were secreted into the culture broth of *C. polyzona* as the nutrients became limited. Proteolytic enzymes are reported to play different roles in the physiology of ligninolytic fungi, such as activation of zymogenic enzymes or release of enzymes from the fungal cell walls (Dosoretz *et al.*, 1990). The production of extracellular proteases is a common feature among fungi and wood-degrading basidiomycetes are also reported to produce such enzymes (Eriksson and Pettersson, 1982). Intra- and extracellular proteases have been shown to affect the regulation of laccase and peroxidase activity in cultures of *T. versicolor* under nutrient limitation. Indeed, addition of protease inhibitor, such as PMSF (irreversible inhibitor of serine proteinases) into the culture of *T. versicolor* significantly enhanced the activity of laccase (Staszczak *et al.*, 2000). It was also reported that *P. ostreatus* extracellular proteases may be involved in the regulation of laccase activity by degrading or activating different isoenzymes (Palmieri *et al.*, 2001). When small amount of PMSF was applied in the fermentation of *C. polyzona*, no fluctuation of laccase activity was observed during the time course of fermentation

according to recent studies (personal communication).

4.2.5 Effect of Fed-batch Mode in Laccase Production by *C. polyzona* in Stirred Tank Reactor

Fed-batch fermentation is powerful tool for the improvement of metabolite production in liquid cultures of many fungi. The main advantage of the fed-batch operation is the possibility to control both reaction rate and metabolic reactions by substrate feeding rate, therefore to avoid the oxygen and mass transfer limitations as often encountered in the batch culture. Fed-batch of carbon source (glucose) and nitrogen source (yeast extract and polypeptone) resulted in 1.7 times as high as that of only glucose fed-batch culture in producing peroxidase by *Arthromyces ramosus* (Tsujimura *et al.*, 1994).

In fed-batch fermentation of *C. polyzona*, the maximum laccase activity of 109,600 U/l and 110,500 U/l were achieved respectively in 2 litre stirred tank reactors. These levels of laccase produced by *C. polyzona* are remarkably higher compared to the reported laccase production by other fungi, where maximum laccase activity of up to 30,000 U/l is reported (Eggert *et al.*, 1996b, Collins and Dobson, 1997, Herpoël *et al.*, 2000). The technique employing a pre-culture inoculum, yielding many small pellets with a fairly homogeneous size distribution, is widely used in production of laccases by white-rot fungi such as *T. versicolor* and *T. pubescens* (Galhaup *et al.*, 2002b, Tavares *et al.*, 2005). Spore suspension has been adopted for laccase production by *P. cinnabarinus* in a 100 litre fermenter with the maximal laccase activity of 18,000 U/l (Eggert *et al.*, 1996).

The highest laccase activity achieved in stirred tank reactors ranging from 2 litre to 150 litre suggest that fed-batch fermentation is suitable for achieving high laccase activity by *C. polyzona*. When fed-batch fermentation was carried out in 20 litre bioreactor, great enhancement in the laccase production level was achieved. The

laccase activity profiles obtained in both 2 litre and 20 litre bioreactors confirms that the cultures could be scaled up with a considerable increase in the level of laccase activity. The laccase activity was enhanced by 56.8% in 20 litre bioreactor when compared to that in 2 litre bioreactor, resulting in 254,700 U/l. The enhancement was due to combined effect of the various factors including better mixing and adoption of fed-batch mode of fermentation. Moreover, it was observed that high level of laccase activity was maintained for longer period when the fermentation was carried out in 20 litre bioreactor compared to that in 2 litre bioreactor. The production of laccase in 20 litre stirred tank bioreactor was prolonged by addition of fresh nutrients and inducer in 1/5 strength of their original concentrations, which confirmed fed-batch a very promising strategy for improved laccase production by *C. polyzona*. The fed-batch strategy was adopted in laccase production of laccases by *T. pubescens*, which resulted in high level of laccase activity (Galhaup and Haltrich, 2001). Although the fermentation in 150 litre stirred tank reactor was terminated because of mechanical operational problems, *C. polyzona* has proved its scale up potential with enhanced laccase production in large scale bioreactor. However, the individual addition of substrates and their time of addition require detailed investigation from the economic point of view. Fed-batch fermentation has shown to be very effective for the production of laccases by white rot fungi in bioreactors. This strategy allows controlling the growth rate by regulating substrate concentration and its rate of addition. Galhaup and co-workers found the efficient production phase could be prolonged by continuously feeding low amounts of glucose to fermenter (Galhaup *et al.*, 2002b). Moreover, the sequential addition of the nutrients (copper, glucose, cellulose, fructose and glycerol) was applied in laccase production by *T. hirsuta* in an air-lift bioreactor and resulted in high laccase activity of 19, 394 U/l (Rodriguez Couto *et al.*, 2006).

4.2.6 Effect of Inducers

4.2.6.1 *Relationship between Ferulic acid and Biomass*

The time course of *C. polyzona* fermentation in the 5 litre bioreactor (Figure 3.22)

showed a decrease in biomass concentration after the addition of ferulic acid. This is probably due to the toxicity of ferulic acid towards *C. polyzona*. A similar observation regarding the effect of aromatic inducer VA on biomass was reported for *Botryosphaeria rhodina* (MAMB-05). The growing culture of *B. rhodina* tolerated high concentration of 30.4 mM VA. The addition of VA to *B. rhodina* resulted in higher levels of laccases but a decrease in biomass (Dekker *et al.*, 2007). However, ferulic acid is proved to be a good inducer for the enhancement of laccase production not only in cultures of *C. polyzona* but also other laccase-producing white rot fungi, such as *P. sajor-caju* (Soden and Dobson, 2001), *P. sanguineus* and *P. ostreatus* (Vanhulle *et al.*, 2007). Our studies indicate that the addition of ferulic acid at high concentration could have negative effect in laccase production. For example, in the case of *P. ostreatus*, concentration above 0.5 mM ferulic acid had a negative impact on laccase production. Therefore, it is important to study the toxic effect of ferulic acid on different white rot fungi where necessary.

4.2.6.2 *Effect of Lignocellulosic Wastes on Laccase Activity of C. polyzona in Submerged Culture*

The potential of wood powder as a substrate for laccase production by *C. polyzona* was investigated in shaken flask and bioreactor. Cellulose and hemicellulose fractions in wood served as carbon sources and could contribute to an sufficient C: N ratio for an effective laccase induction of the strain. In the liquid culture of *P. chrysosporium* BKM-F1767, laccase was only detected when grown on substrates containing cellulose or wood. The cellulose and lignocellulosic residues were considered to stimulate laccase production (Srinivasan *et al.*, 1995).

On the other hand, the enhanced laccase activity during the fermentation of *C. polyzona* with the addition of oak wood powder could be caused by small amounts of aromatic compounds from lignin, such as phenols, low-molecular-mass

compounds and macromolecules containing phenolic groups, which could induce laccase production. It was reported that lignin-related phenols and compounds played positive effect on laccase production by white-rot fungi (Dekker *et al.*, 2002), the induction mechanism of wood powder are similar to other inducers such as 2, 5-xylidine, ferulic acid and veratryl alcohol. When the white rot fungus *T. versicolor* was grown on glucose, wheat straw and beech wood under static conditions to produce extracellular laccase respectively, there was no direct contact between the mycelia and the lignocellulose-containing substrates wheat straw and beech wood, in the experiment design. The presence of water-soluble constituents from lignin or lignocellulose fractions of the wheat straw and beech wood such as *p*-coumaryl alcohol, coniferyl alcohol, sinapyl alcohol and other aromatic compounds, might result in the increased laccase activities in comparison to the growth on glucose (Schlosser *et al.*, 1997).

Other lignocellulosic wastes, such as barely bran, grape seeds, grape stalks, were also employed to improve laccase production by white rot fungus *T. versicolor* under shaking condition (Lorenzo *et al.*, 2002, Moldes *et al.*, 2004). Lignocellulosic materials comprise a broad range of wastes from agricultural, food and forest industry. These materials not only stimulate laccase production by white rot fungi but also provide some of the necessary nutrients for the fungi, which therefore could greatly reduce the cost of laccase production. Furthermore, recent studies have revealed that rapeseed cake is very promising alternative substrate in laccase production by *C. polyzona* from both economical and environmental points of view. The maximal laccase activity of 120,000 U/l was achieved using rapeseed cake as sole substrate in 5 liter stirred tank reactor (personal communication).

4.3 Characterisation of Laccases from *C. polyzona*

C. polyzona secreted laccases with high activity in ferulic acid induced complex

medium. Two laccase isoforms (Lac I and Lac II) were expressed with partially different physico-chemical characteristics and catalytic properties. The results reported here are the first to indicate two isoenzymes are produced by this strain.

White rot fungi typically produce multiple isoenzymes (Bollag and Leonowicz, 1984, Eggert *et al.*, 1997). Some produce laccases constitutively, whereas others produce laccases after induction. Many white rot fungi have been reported to produce multiple laccase isoenzymes, such as *C. unicolor* strain 137 (Michniewicz *et al.*, 2006), *Coriolopsis rigida* (Saparrat *et al.*, 2002), *P. ostreatus* (Palmieri *et al.*, 2000, Palmieri *et al.*, 2001, Palmieri *et al.*, 2003), *T. pubescens* (Galhaup *et al.*, 2002a) and *T. villosa* (Muñoz *et al.*, 1997).

Most laccases are monomeric glycoproteins showing a molecular mass between 50 and 80kDa (Thurston, 1994). In the case of *C. polyzona*, the M_w of Lac I and Lac II (64kDa) fit well within the values reported from other white rot fungi, such as *T. pubescens* (65kDa) and *P. eryngii* (61-65kDa) (Muñoz *et al.*, 1997, Galhaup *et al.*, 2002a). The pI of both isoenzymes (pI 4.2) are in the acidic range, which are reported for laccases produced from other white rot fungi, including two laccases from *P. eryngii* (pI: 3.90 and 3.95) (Muñoz *et al.*, 1997), *P. ostreatus* (pI: 4.1 and 4.3) (Palmieri *et al.*, 2003), and *P. cinnabarinus* (pI 3.7) (Eggert *et al.*, 1996). Compared with other fungal laccases, purified isoenzymes from *C. polyzona* showed typical characteristics of a laccase.

Fungal laccases are generally active at low pH values (pH 3-5) (Bollag and Leonowicz, 1984). Although optimum pH of *C. polyzona* laccases varies depending on substrates applied, however, it exhibited maximum activity at pH 3-5, which falls within the common optimum pH range of white rot fungi. *C. polyzona* isoforms were stable at neutral pH and had excellent long term stability of 72 hours at room temperature. *C. polyzona* isoenzymes, like other fungal laccases, showed a wide

substrate specificity oxidizing several hydroxyl- and methoxy-substituted phenols, such as DMP, SYN, etc. but had no activity toward tyrosine. In general, increasing the number of substituted methoxyl groups increased oxidation rate (Chefetz *et al.*, 1998). The purified laccases are sensitive to sodium azide like other fungal laccases (Bollag and Leonowicz, 1984). Total inhibition of laccase activity from *P. eryngii* was found with 0.05 mM sodium azide (Muñoz *et al.*, 1997), whereas with 0.5 mM sodium azide in the case of *C. polyzona* isozymes. The *C. polyzona* isoenzymes were much less sensitive to metal chelation by EDTA than laccases of *Coriolus hirsutus* and *P. cinnabarinus* (Eggert *et al.*, 1996).

Fungal laccases are known to possess a very wide range of substrate affinities (Mayer, 1987, Eggert *et al.*, 1996) and even the laccase isozymes of the same strain may also show differences in substrate affinities (Fukushima and Kirk, 1995, Muñoz *et al.*, 1997, Michniewicz *et al.*, 2006). Lac I and Lac II from *C. polyzona* oxidized phenolic compounds 2, 6-DMP, the complex syringaldazine and non-phenolic heterocyclic compounds (ABTS) with different specifications. In kinetic studies, Lac I shows a higher affinity to any selected substrates as the K_m values of Lac I were lower than those of Lac II. *C. polyzona* laccases show a low affinity to 2, 6-DMP, resulting in slower oxidation than ABTS and syringaldazine. These catalytic properties were also reported for laccases from *C. unicolor*. Despite of the highly conserved catalytic copper sites found in all the known laccase gene sequences, differences in laccase activity from different species against various substrates have been observed. Therefore, more studies on gene sequences will help to develop a better understanding of the structure-function relationships that determine substrate specificities and functions of laccases in different biological system (Eggert *et al.*, 1997).

Mass spectral analysis of protein tryptic digestion products provides information which differs from the identification carried out through details of origin and physio-chemical properties (Shleev *et al.*, 2006). The ‘peptide mass mapping’ approach often

results in the identification of a gene-product in most cases, instead of gene itself (Lasonder *et al.*, 2002). The mass patterns of the tryptic digest products of Lac I and Lac II from *C. polyzona* suggested a broad similarity between these two proteins. However, we could not determine whether or not a single gene codes for both enzymes. It remains a subject for future investigation to figure out if Lac I and Lac II are constitutive laccase multiforms simultaneously produced by basidiomycete *C. polyzona*, which could be formed during post-translational modification, e.g. through glycosylation and/or partial degradation of the polypeptide chain. If the latter is the case, one gene could possibly code for several multienzymes under specific conditions. The total amount of all possible laccase isoforms from *C. polyzona* would be more but they are unknown value at present.

4.4 Decolourisation of Single and Mixed Dyes by Purified Laccase and Whole Cell Culture of *C. polyzona*

4.4.1 Laccase and Laccase-mediator System on Decolourisation of Single and Mixed dyes

Laccases have been shown to decolourise anthraquinone dyes more efficiently than azo dyes and triarylmethane dyes (Claus *et al.*, 2002). The purified laccase from *C. polyzona* was able to efficiently decolourise acid blue 62 and acid black 194 that were also decolourised by laccases from *P. sanguineus* (Vanhulle *et al.*, 2008) and *C. gallica* (Reyes *et al.*, 1999) respectively. For a laccase from *C. polyzona*, anthraquinone dye (acid blue 62) was found to be a better substrate than azo dye (acid black 194). However, the laccase from *C. polyzona* was unable to decolourise reactive black 5 and direct blue 71. In the literature, reactive black 5 and direct blue 71 could be decolourised by laccases from *T. versicolor* (Champagne and Ramsay, 2005) and *T. modesta* (Nyanhongo *et al.*, 2002). This is caused by different characteristics of individual laccases regarding their redox potential or dyes' structures, which results in differences in substrate specificity. It has been reported that the different redox potential of laccases, which usually range between 0.4 and

0.8V, rather than their steric effects, determine the substrate specificities of these enzymes (Xu, 1996, Nyanhongo *et al.*, 2002). The observations that azo dyes were recalcitrant to decolourisation or could decolourise only to a limited extent compared with anthraquinone dyes agree well with the previous findings from other researchers (Wong and Yu, 1999, Claus *et al.*, 2002). Similar results were obtained from laccases from *T. hirsuta*, *T. versicolor* and *Polyporus pinisitus* (Abadulla, 2000, Claus *et al.*, 2002). As for azo dyes oxidation, the differences may contribute to the different electron-donating properties of the substituents and their location on the phenolic ring. When an azo dye is oxidised by a laccase, it allows the enzymatic generation of a phenoxy radical and a breakdown mechanism that results in the cleavage of azo linkages and release of molecular nitrogen. As a result, the decolourisation of azo dyes occurs and toxic aromatic amine is excluded.

When applying the laccase secreted by *C. polyzona* to different types of industrial effluents containing mixed dyes, similar results were obtained. The laccase from *C. polyzona* appears to be a good candidate for their applications in acid dye bath treatments containing anthraquinone dyes, whereas there was no decolourisation observed in direct and reactive dye baths.

Direct blue 71 was not oxidised by laccase from *C. polyzona*, however, it was the preferred substrate for the laccases from *T. hirsute* (Abadulla, 2000) and *T. modesta* (Tauber *et al.*, 2008). This might be due to lower redox potential of *C. polyzona* laccase compared to *T. hirsute* and *T. modesta*. Moreover, model dye wastewater containing single dye used in this study exhibit high pH and contain high salt concentration. This might decrease efficiency of *C. polyzona* laccase in decolourisation of direct blue 71. Currently, only a few comparative data are available concerning the activity and/or the stability of laccases at different ionic strengths. However, the addition of chloride ions seems to usually inhibit the catalytic activity of the enzyme: for example, a 80% inhibition was described for *Pleurotus florida* laccase in presence of 50 mM NaCl (Das *et al.*, 2001). In contrast,

P. sanguineus strain (MUCL 41582, PS7) retained about 50% of its activity in presence of salts (NaCl or Na₂SO₄) concentrations up to 1 M and retained more than 55-60% and 75-80% (Trovasset et al., 2007). Therefore, the existence of NaCl or Na₂SO₄ in the wastewater model might restrict laccase catalysed dye degradation from *C. polyzona*. Reactive black 5 was not oxidised by laccase from *C. polyzona*. This is probably due to the high redox potential of this dye, which are not oxidised by chemical oxidisers such as Mn³⁺, but steric hindrance may also reduce the accessibility of the –OH and –NH₂ groups in the reactive black 5 by laccase.

The addition of redox mediators leads to the decolourisation of a broader spectrum of synthetic dyes or to the increase in decolourisation rates (Champagne and Ramsay, 2005, Couto and Sanroman, 2007, Kokol *et al.*, 2007). As an oxidase, laccase can oxidize the substrate molecules by taking four electrons from the compound while the four Cu²⁺ of its active centre are reduced to Cu⁺. The reduced laccase returns to the original status by transferring the electrons to the dioxygen (O⁰) and producing water (O²⁻). The oxidized substrate is an active cation radical and automatically decomposes into simple products. If the cation radicals have long enough life-time, however, they might take electron from other electron-rich compounds such as the synthetic dyes and return to their original status. Because of this electron transfer, a non-substrate dye can be oxidised by laccase through a mediator like ABTS (Wong and Yu, 1999). Therefore, laccase from *C. polyzona* could oxidize non-substrate azo dyes.

Our studies suggest that there is no need for the mediators (ABTS or VA) to achieve comparable or better decolourisation in anthraquinone dye. The addition of ABTS and VA showed no significant effect, whereas in the case of azo dyes, acid black 194, reactive black 5 and direct 71, higher percentage of decolourisation was achieved with the addition of mediators. It was found that the addition of ABTS had no significant effect on improving reactive and direct model dye decolourisation (data not shown). Comparatively, VA was found to be a much more efficient mediator than ABTS not only in decolourisation of single dyes such as reactive black 5 and direct

71 but also in the reactive and direct dye baths. It is mostly due to the high pH of the dye effluent preparation. ABTS cation radical tends to lose its stability as pH increases. It is more stable at low pH, such as pH 6.0. VA is an N-hydroxy compound that has been reported to be a very effective mediator for laccase oxidation reactions among several mediators tested (Soares *et al.*, 2001, Soares *et al.*, 2002). Couto and Sanroman also tested its efficiency as a redox mediator for the decolourisation of the two recalcitrant acid dyes, Acid Red 97 (AR 97) and Acid Green 26 (AC 26) by laccase from *T. hirsute* (Couto and Sanroman, 2007). The decolourisation of AR 97 by *T. hirsute* with the addition of VA was enhanced 3 fold and its decolourisation rate increased greatly.

In this study, VA greatly improved RB 5 and DB 71 as well as reactive and direct dye baths under high pH and salt concentration conditions. However, the extent to which VA enhances the laccase catalyzed reactions depends on the nature of the dyes. Studies showed that the efficiency of different mediators is related to dyes to be treated (Camarero *et al.*, 2005). Although it is beyond the scope of this study to provide a mechanism for the interpretation of the observed results, which requires analysis and identification of the reaction products, it is important to know that the redox potential of laccases varied depending on the sources of laccases (Li *et al.*, 1999). The nitroxyl radical generated from VA is quite stable, which may be attributed to its low redox potential. Due to its 200-300 mV lower redox potential (E^0) compared to another mediator 1-hydroxybenzotriazole (HBT), VA is more stable and more easily oxidized by laccases, and has been reported to be more effective, as a mediator, compared to HBT in delignification (Kurniawati and Nicell, 2007). The redox mediators increased significantly the decolourisation percentage of all tested dyes not only when combined with purified laccases, but also when added to the supernatant from *C. polyzona* culture. This is quite important from the technological point of view that the culture liquid can be used for decolourisation without the involvement of purification steps for the laccases or other ligninolytic enzymes.

4.4.2 Effect of Mn²⁺ and H₂O₂ on dye decolourisation by laccase from *C. polyzona*

The results showed that the addition of MnSO₄ and/or H₂O₂ slightly enhance decolourisation percentage by laccase of *C. polyzona*, which may reflect the ability of laccase to catalyze the production of manganic chelate from MnSO₄ (Archibald and Roy, 1992, Hofer and Schlosser, 1999). Although dye decolourisation with fungal culture and purified ligninolytic enzymes attracted considerable attention for their wide applications, the contribution of different enzymes from fungal cultures in dye decolourisation is yet to be fully understood. It is possible that laccase may cooperate with MnP in dye decolourisation leading to higher decolourisation percentage obtained in the treatment with supernatan. Schlosser and Hofer (2002) demonstrated interaction between MnP and laccase from *Stropharia rugosoannulata*, where laccase indirectly produced H₂O₂ by oxidizing Mn²⁺. This type of cooperation may enhance reaction rates when both enzymes are present. It seems that the role of MnP from *C. polyzona* in decolourisation is negligible since the addition of Mn²⁺ and H₂O₂ to the culture liquid did not increase decolourisation rate of the dyes (Kokol *et al.*, 2007).

4.4.3 Application of Response Surface Technology to Optimise Reactive Black 5 Decolourisation by Purified Laccase from *C. polyzona*

This work has reported, for the first time, the application of response surface technology to investigate the effect of laccase from *C. polyzona*, pH and redox mediator VA on RB5 decolourisation. A quadratic equation was established to demonstrate the relationship between decolourisation percentage of RB5 and the three variables in the design. The experimental values were in good agreement with predicted ones and the model was highly significant with the correlation coefficient being 0.974. The limitation for the use of *C. polyzona* cultures for decolourisation is the acidic pH range for the activity. This is similar to other white-rot fungi. Effluents from textile industry always contain mixed dyes and often exhibit high pH in the presence of auxiliary dyeing compounds which are not favoured to culture liquid and

purified laccase from white rot fungi in term of dye decolourisation because low pH is essential in fungal cultures for their metabolic activity. However, *C. polyzona* culture liquid was able to decolourise not only the synthetic dye solutions at acidic pH but also synthetic dye baths at high pH containing inorganic salts with the combination of mediator VA. The Box-Behnken and central composite experiment designs were applied in decolourisation of RB5 by laccase from *P. sajor-caju* and *T. pubescens* respectively with the addition of HBT as mediator (Murugesan *et al.*, 2007, Roriz *et al.*, 2009) and biodegradation of reactive dye (Verofix Red) by *P. chrysosporium* (Nagarajan, 1999).

CHAPTER 5: CONCLUSION

As indicated in Introduction Chapter, oxidative enzyme-based methods for wastewater treatment have minimal impact on ecosystems and low energy requirements. Enzymes can operate in a wide pH range at moderate temperature and ionic strength. Among oxidative enzymes, increasing attention has been paid to laccases from white rot fungi as potential industrial enzymes for dye bioremediation. Therefore, it is very important to design and develop a robust and economic bio-based process of production of laccases.

This thesis provides a comparison of three selected basidiomycete strains for their ability to produce laccases in shaken flask fermentation. Wood-degrading basidiomycete *C. polyzona* was found to be an excellent producer of laccases in both shaken flasks and bioreactors. Moreover, laccase production by *C. polyzona* was successfully scaled up from shaken flask to bioreactors with significantly enhanced laccase activity including 2-litre, 5-litre, 20-litre as well as a trial run in 150-litre. Conidia inoculation showed its advantages over mycelium inoculation from operational point of view for the scale up. It is suggested that there are two factors that might lead to high laccase activity by *C. polyzona*. One factor is the presence of the inducer, ferulic acid, in the millimolar range in the glucose-bactopeptone medium that stimulates laccase production. The other factor is the fed-batch mode of operation. The fed-batch mode demonstrated its efficiency in enhancing laccase production in large scale fermentation of *C. polyzona*. The addition of lignocellulosic wastes, such as oak wood powder resulted in higher laccase activity by *C. polyzona*. The recent studies of rapeseed cake as an alternative substrate to complex medium showed promising results (personal communication).

It is well known that laccases are a family of enzymes that are generally produced in a pattern of isoenzymes with different properties. Isoenzymes from *C. polyzona* were

purified with the final yield of 10% and further characterisation results showed typical characteristics of laccases when compared with other fungal laccases regarding molecular weight, isoelectric point (pI), pH and temperature optimum as well as thermostability. The kinetic parameters of Lac I and II showed higher affinity for the widely used substrate ABTS when compared with other laccases from available publications. Further investigation on physico-chemical properties of laccases from *C. polyzona* provides detailed information for their industrial applications, particularly in dye decolourisation.

Crude and purified laccase were used as biocatalyst for the decolourisation of textile effluent containing single dyes or mixed dyes. The results suggested that purified Lac I presented high decolorizing ability for anthraquinonic dyes without the requirement of redox mediators. For azo dyes, mediators are required depending on the structure of dyes. The laccase-mediator system proved to be efficient for decolourisation of reactive and direct dyes. The decolourisation of these dyes occurred when the textile dye mixtures were supplemented with low amount of mediators. Both of the mediators VA and ABTS affected the decolourisation rate of Lac I. 2.5 mM VA gave faster decolourisation rate compared to 2.5 mM ABTS. Laccase activity of 100 U/l was applied in the dye decolourisation experiments with high decolourisation ability, thus Lac I has been proved to be a very useful enzyme for dye decolourisation. When crude laccase from *C. polyzona* was applied in textile effluent, it slightly enhanced decolourisation percentage compared to purified Lac I.

RSM including experimental design and regression analysis is effective in developing an analysis model, finding the optimal point of the interacting factors and accessing the effects of the factors. The strategy demonstrates advantages over traditional methods and allows the development of a mathematical model that predicts the optimal condition. From the point of view of saving cost and time in bio-industry, RSM together with other statistical modelling methods have gained increasing importance. In this study, RSM has been successfully applied to evaluate the effect of

ferulic acid and MO on laccase production by three selected white rot fungi, and to determine the optimal operational conditions for the highest decolourisation of RB 5. A quadratic model was successfully developed to represent the RB5 decolourisation percentage in terms of laccase activity, pH and [VA] and the corresponding coefficient of independent variables was determined.

In conclusion, the studies carried out in this project have provided an efficient method for large-scale production of laccases with high activity suitable for use in the bioindustry with particular reference to dye effluents from the textile plants. It is concluded that the investigations of *C. polyzona* provides a feasible fermentation for laccases with industrial utility.

CHAPTER 6: FUTURE WORK

Since *C. polyzona* laccase is a good candidate for industrial effluent treatment as well as other biotechnological applications, large amounts of laccases with high activity are required at low cost. More research needs to be carried out to improve laccase production with reducing cost, which includes further medium optimisation considering variety of cheap biological waste material such as lignocellulosic wastes and other agricultural waste. Increasing attention is being paid to lignocellulosic wastes as media ingredients for laccase production by white rot fungi due to their wide availability and cheap price. Different lignocellulosic wastes should be applied and compared for achieving high laccase production by *C. polyzona* with reduced price.

Due to the relatively low yield of laccases obtained by the existing purification process, further small scale experiments shall be carried out to optimise the procedures and parameters at different purification steps in order to achieve high yield, and a robust scalable purification process. Resin scouting shall be performed initially. RSM could be used to find the optimal buffer system in terms of buffer type, pH and concentration for the chosen resin. Depending on the optimisation results from downstream, alternative combination of chromatography might be considered to increase overall yield. In addition, it will be worthwhile to study the effect of particular stabiliser CuSO_4 and protease inhibitor PMSF on laccase purification from *C. polyzona*.

This thesis has provided information on the decolourisation ability of the whole cell culture of *C. polyzona* as well as Lac I. It is worthwhile to know if other isoenzyme of laccase (Lac II) and other enzymes, such as LiP or MnP, have been involved in the dye decolourisation.

Increasing attention has been paid to the application of white rot fungi and their lignin-modifying enzymes, particularly laccases, to decolourisation. Decolourisation does not necessarily imply detoxification. It is possible that the molecules synthesised during the decolourisation reaction are less toxic but it is also possible that other toxic molecules may be synthesised. It is suggested that wastewater treatment efficiency should be evaluated through complementary toxicological parameters (Vanhulle *et al.*, 2008). Therefore, it is important to perform toxicity test on the textile effluents after they have been treated with laccases from *C. polyzona*. Various examples for application of the luminescent bacteria test in textiles have been discussed. The oxygen consumption rate of *Pseudomonas putida* has been used as a parameter to monitor detoxification (Abadulla, 2000). Alternatively, cytotoxicity assay could be performed on classical bacterial cells and human Caco-2 cells, which are considered as a valid model for human intestinal epithelium. Genotoxicity of dye effluent after treatment could be monitored using VITOTOX[®] kit.

Further extensive studies are required to ensure the efficiency of dye bioremediation process, including mechanisms between different types of dyes and laccases or whole culture of *C. polyzona*, and selection of mediators. As most of mediators tend to be expensive and toxic, their use is not desirable both from the environment and the cost point of view. Thus, it is worthwhile to find alternative solutions to improve dye bioremediation process, for example, using whole culture broth containing natural mediators or improving the yield of laccases and their characteristics using genetic engineering approaches.

REFERENCE

- Abadulla, E. (2000) Decolorization and detoxification of textile dyes with a laccase from *Trametes hirsuta*. *Applied and environmental microbiology*, 66, 3357-3362.
- Aggelis, G., Iconomou, D., Christou, M., Bokas, D., Kotzailias, S., Christou, G., Tsagou, V. & Papanikolaou, S. (2003) Phenolic removal in a model olive oil mill wastewater using *Pleurotus ostreatus* in bioreactor cultures and biological evaluation of the process. *Water Research*, 37, 3897-3904.
- Ahn, M. Y., Dec, J., Kim, J. E. & Bollag, J. M. (2000) Treatment of 2,4-Dichlorophenol polluted soil with free and immobilized laccase. *Bouyoucos 2000 Conference*. Corpus Christi, Texas, Amer Soc Agronomy.
- Albersheim, P., Valent, B. S., Ayers, A. R., Ebel, J. & Thomas, S. R. (1977) molecular-interactions between plants and their pathogens - towards development of ecologically attractive pesticides. *Proceedings of the Australian Biochemical Society*, 10, P4-P4.
- Albersheim, P., Darvill, A., Augur, C., Cheong, J. J., Eberhard, S., Hahn, M. G., Marfa, V., Mohnen, D., Oneill, M. A., Spiro, M. D. & York, W. S. (1992) Oligosaccharins - oligosaccharide regulatory molecules. *Accounts of Chemical Research*, 25, 77-83.
- Alexandre, G. & Zhulin, I. B. (2000) Laccases are widespread in bacteria. *Trends in Biotechnology*, 18, 41-42.
- Alsubaey, A., Sisler, H. D. & Matthews, B. F. (1996) Purification and characterization of an extracellular phenol oxidase from culture filtrates of *Pyricularia oryzae*. *Canadian Journal of Microbiology*, 42, 437-445.
- Ander, P. & Eriksson, K. E. L. (1978) Lignin degradation and utilisation by microorganisms. *Progress in Industrial Microbiology*, 1-58.
- Andrea, Z. (2005) Laccase reactions for textile applications. PhD thesis *Textile Department*. Portugal University of Minho.

- Aramayo, R. & Timberlake, W. E. (1990) Sequence and molecular-structure of the *Aspergillus nidulans* Ya (Laccase-I) Gene. *Nucleic Acids Research*, 18, 3415-3415.
- Archibald, F. & Roy, B. (1992) Production of manganic chelates by laccase from the lignin-degrading fungus *Trametes (Coriolus) versicolor*. *Applied and environmental microbiology*, 58, 1496-1499.
- Archibald, F. S., Bourbonnais, R., Jurasek, L., Paice, M. G. & Reid, I. D. (1997) Kraft pulp bleaching and delignification by *Trametes versicolor*. *Journal of Biotechnology*, 53, 215-236.
- Ariyo, B. T., Bucke, C. & Keshavarz, T. (1997) Alginate oligosaccharides as enhancers of penicillin production in cultures of *Penicillium chrysogenum*. *Biotechnology and Bioengineering*, 53, 17-20.
- Arora, D. S. & Gill, P. K. (2001) Effects of various media and supplements on laccase production by some white rot fungi. *Bioresource Technology*, 77, 89-91.
- Asilonu, E., Bucke, C. & Keshavarz, T. (2000) Enhancement of chrysogenin production in cultures of *Penicillium chrysogenum* by uronic acid oligosaccharides. *Biotechnology Letters*, 22, 931-936.
- Bailey, M. J., Adamitsch, E., Rautio, J., Von Weymarn, N. & Saloheimo, M. (2007) Use of a growth-associated control algorithm for efficient production of a heterologous laccase in *Trichoderma reesei* in fed-batch and continuous cultivation. *Enzyme and Microbial Technology*, 41, 484-491.
- Baldrian, P. (2003) Interactions of heavy metals with white-rot fungi. *Enzyme and Microbial Technology*, 32, 78-91.
- Baldrian, P. (2006) Fungal laccases - occurrence and properties. *Fems Microbiology Reviews*, 30, 215-242.
- Banci, L., Ciofi-Baffoni, S. & Tien, M. (1999) Lignin and Mn peroxidase-catalyzed oxidation of phenolic lignin oligomers. *Biochemistry*, 38, 3205-3210.

- Berka, R. M., Schneider, P., Golightly, E. J., Brown, S. H., Madden, M., Brown, K. M., Halkier, T., Mondorf, K. & Xu, F. (1997) Characterization of the gene encoding an extracellular laccase of *Myceliophthora thermophila* and analysis of the recombinant enzyme expressed in *Aspergillus oryzae*. *Applied and Environmental Microbiology*, 63, 3151-3157.
- Bettin, F., Montanari, Q., Calloni, R., Gaio, T. A., Silveira, M. M. & Dillon, A. J. P. (2009) Production of laccases in submerged process by *Pleurotus sajor-caju* PS-2001 in relation to carbon and organic nitrogen sources, antifoams and Tween 80. *Journal of Industrial Microbiology & Biotechnology*, 36, 1-9.
- Bollag, J. M. & Leonowicz, A. (1984) Comparative studies of extracellular fungal laccases. *Applied and Environmental Microbiology*, 48, 849-854.
- Bonnarme, P. & Jeffries, T. W. (1990) Selective Production of Extracellular Peroxidases from *Phanerochaete-Chrysosporium* in an Airlift Bioreactor. *Journal of Fermentation and Bioengineering*, 70, 158-163.
- Bourbonnais, R. & Paice, M. G. (1990) Oxidation of nonphenolic substrates - an expanded role for laccase in lignin biodegradation. *Febs Letters*, 267, 99-102.
- Bourbonnais, R. & Paice, M. G. (1992) Demethylation and delignification of kraft pulp by *Trametes versicolor* laccase in the presence of 2,2'-azinobis(3-ethylbenzthiazoline-6-sulfonate). *Applied Microbiology and Biotechnology*, 36, 823-827.
- Bourbonnais, R., Paice, M. G., Reid, I. D., Lanthier, P. & Yaguchi, M. (1995) Lignin Oxidation by laccase isozymes from *Trametes versicolor* and role of the mediator 2,2'-azinobis(3-ethylbenzthiazoline-6-sulfonate) in kraft lignin depolymerization. *Appl Environ Microbiol*, 61, 1876-1880.
- Bourbonnais, R., Paice, M. G., Freiermuth, B., Bodie, E. & Borneman, S. (1997) Reactivities of various mediators and laccases with kraft pulp and lignin model compounds. *Applied and Environmental Microbiology*, 63, 4627-4632.

- Bourbonnais, R., Leech, D. & Paice, M. G. (1998) Electrochemical analysis of the interactions of laccase mediators with lignin model compounds. *Biochimica Et Biophysica Acta-General Subjects*, 1379, 381-390.
- Box, G. E. P. & Wilson, K. B. (1951) On the experimental attainment of optimum conditions. *Journal of the Royal Statistical Society Series B-Statistical Methodology*, 13, 1-45.
- Box, G. E. P. & Hunter, J. S. (1957) Multi-factorial designs for exploring response surfaces. *Ann. Math. Stat.*, 195-241.
- Bulter, T., Alcalde, M., Sieber, V., Meinhold, P., Schlachtbauer, C. & Arnold, F. H. (2003) Functional expression of a fungal laccase in *Saccharomyces cerevisiae* by directed evolution. *Applied and Environmental Microbiology*, 69, 987-995.
- Buswell, J. A., Cai, Y. J. & Chang, S. T. (1995) Effect of nutrient nitrogen and manganese on manganese peroxidase and laccase production by *Lentinula (Lentinus) Edodes*. *Fems Microbiology Letters*, 128, 81-87.
- Calvo, A. M., Copa-Patino, J. L., Alonso, O. & Gonzalez, A. E. (1998) Studies of the production and characterization of laccase activity in the basidiomycete *Coriolopsis gallica*, an efficient decolorizer of alkaline effluents. *Archives of Microbiology*, 171, 31-36.
- Camarero, S., Ibarra, D., Martinez, M. J. & Martinez, A. T. (2005) Lignin-derived compounds as efficient laccase mediators for decolorization of different types of recalcitrant dyes. *Applied and environmental microbiology*, 71, 1775-1784.
- Castro, P. M. L., Hayter, P. M., Ison, A. P. & Bull, A. T. (1992) Application of a statistical design to the optimization of culture-medium for recombinant interferon-gamma production by chinese-hamster ovary cells. *Applied Microbiology and Biotechnology*, 38, 84-90.
- Chagas, E. P. & Durrant, L. R. (2001) Decolorization of azo dyes by *Phanerochaete chrysosporium* and *Pleurotus sajorcaju*. *Enzyme and microbial technology*, 29, 473-477.

- Champagne, P. P. & Ramsay, J. A. (2005) Contribution of manganese peroxidase and laccase to dye decoloration by *Trametes versicolor*. *Appl Microbiol Biotechnol*, 69, 276-285.
- Chao, W. L. & Lee, S. L. (1994) Decoloration of azo dyes by 3 white-rot fungi - influence of carbon source. *World journal of microbiology & biotechnology*, 10, 556-559.
- Chefetz, B., Chen, Y. & Hadar, Y. (1998) Purification and characterization of laccase from *Chaetomium thermophilum* and its role in humification. *Applied and Environmental Microbiology*, 64, 3175-3179.
- Christie, R. M. (2001) Colour Chemistry, The Royal Society of Chemistry, London.
- Claus, H., Faber, G. & Konig, H. (2002) Redox-mediated decolorization of synthetic dyes by fungal laccases. *Appl Microbiol Biotechnol*, 59, 672-678.
- Claus, H. (2003) Laccases: structure, reactions, distribution. *13th International Conference on Invertebrate Dioxygen Binding Proteins*. Mainz, GERMANY, Pergamon-Elsevier Science Ltd.
- Colao, M. C., Lupino, S., Garzillo, A. M., Buonocore, V. & Ruzzi, M. (2006) Heterologous expression of lcl1 gene from *Trametes trogii* in *Pichia pastoris* and characterization of the recombinant enzyme. *Microbial Cell Factories*, 5, 11.
- Coll, P. M., Fernandezabalos, J. M., Villanueva, J. R., Santamaria, R. & Perez, P. (1993) Purification and characterization of a phenoloxidase (Laccase) from the lignin-degrading basidiomycete PM1 (Cect-2971). *Applied and Environmental Microbiology*, 59, 2607-2613.
- Collins, P. J., Kotterman, M. J. J., Field, J. A. & Dobson, A. D. W. (1996) Oxidation of anthracene and benzo[a]pyrene by laccases from *Trametes versicolor*. *Applied and Environmental Microbiology*, 62, 4563-4567.
- Collins, P. J. & Dobson, A. D. W. (1997) Regulation of laccase gene transcription in *Trametes versicolor*. *Applied and Environmental Microbiology*, 63, 3444-3450.

- Collins, P. J. & Dobson, A. D. W. (1997) Regulation of laccase gene transcription in *Trametes versicolor*. *Appl Environ Microbiol*, 63, 3444-3450.
- Couto, S. R., Moldes, D., Liebanas, A. & Sanroman, A. (2003) Investigation of several bioreactor configurations for laccase production by *Trametes versicolor* operating in solid-state conditions. *Biochemical Engineering Journal*, 15, 21-26.
- Couto, S. R. & Sanroman, M. A. (2007) The effect of violuric acid on the decolorization of recalcitrant dyes by laccase from *Trametes hirsuta*. *Dyes and Pigments*, 74, 123-126.
- Cripps, C., Bumpus, J. A. & Aust, S. D. (1990) Biodegradation of Azo and Heterocyclic Dyes by *Phanerochaete chrysosporium*. *Applied and environmental microbiology*, 56, 1114-1118.
- Cristovao, R. O., Tavares, A. P. M., Ferreira, L. A., Loureiro, J. M., Boaventura, R. A. R. & Macedo, E. A. (2009) Modeling the discoloration of a mixture of reactive textile dyes by commercial laccase. *Bioresource Technology*, 100, 1094-1099.
- D'acunzo, F. & Galli, C. (2003) First evidence of catalytic mediation by phenolic compounds in the laccase-induced oxidation of lignin models. *European Journal of Biochemistry*, 270, 3634-3640.
- D'souza, T. M., Merrit, C. S. & Reddy, C. A. (1999) Lignin-modifying enzymes of the white rot basidiomycete *Ganoderma lucidum*. *Applied and Environmental Microbiology*, 65, 5307-5313.
- Das, N., Chakraborty, T. K. & Mukherjee, M. (2001) Purification and characterization of a growth-regulating laccase from *Pleurotus florida*. *J Basic Microbiol*, 41, 261-267.
- Dekker, R. F. H., Barbosa, A. M. & Sargent, K. (2002) The effect of lignin-related compounds on the growth and production of laccases by the ascomycete, *Botryosphaeria* sp. *Enzyme and Microbial Technology*, 30, 374-380.

- Dekker, R. F. H., Barbosa, A. M., Giese, E. C., Godoy, S. D. S. & Covizzi, L. G. (2007) Influence of nutrients on enhancing laccase production by *Botryosphaeria rhodina* MAMB-05. *International Microbiology*, 10, 177-185.
- Dey, G., Mitra, A., Banerjee, R. & Maiti, B. R. (2001) Enhanced production of amylase by optimization of nutritional constituents using response surface methodology. *Biochemical Engineering Journal*, 7, 227-231.
- Dominguez, A., Couto, S. R. & Sanroman, M. A. (2005) Dye decolorization by *Trametes hirsuta* immobilized into alginate beads. *World Journal of Microbiology & Biotechnology*, 21, 405-409.
- Dong, J. L. & Zhang, Y. Z. (2004) Purification and characterization of two laccase isoenzymes from a ligninolytic fungus *Trametes gallica*. *Preparative Biochemistry & Biotechnology*, 34, 179-194.
- Dosoretz, C. G., Dass, S. B., Reddy, C. A. & Grethlein, H. E. (1990) Protease-mediated degradation of lignin peroxidase in liquid cultures of *Phanerochaete Chrysosporium*. *Applied and Environmental Microbiology*, 56, 3429-3434.
- Ducros, V., Brzozowski, A. M., Wilson, K. S., Brown, S. H., Ostergaard, P., Schneider, P., Yaver, D. S., Pedersen, A. H. & Davies, G. J. (1998) Crystal structure of the type-2 Cu depleted laccase from *Coprinus cinereus* at 2.2 angstrom resolution. *Nature Structural Biology*, 5, 310-316.
- Duran, N. & Esposito, E. (2000) Potential applications of oxidative enzymes and phenoloxidase-like compounds in wastewater and soil treatment: a review. *Applied Catalysis B-Environmental*, 28, 83-99.
- Edens, W. A., Goins, T. Q., Dooley, D. & Henson, J. M. (1999) Purification and characterization of a secreted laccase of *Gaeumannomyces graminis* var. *tritici*. *Applied and Environmental Microbiology*, 65, 3071-3074.
- Eggert, C., Temp, U., Dean, J. F. D. & Eriksson, K. E. L. (1996a) A fungal metabolite mediates degradation of non-phenolic lignin structures and synthetic lignin by laccase. *Febs Letters*, 391, 144-148.

- Eggert, C., Temp, U. & Eriksson, K. E. L. (1996b) The ligninolytic system of the white rot fungus *Pycnoporus cinnabarinus*: Purification and characterization of the laccase. *Applied and Environmental Microbiology*, 62, 1151-1158.
- Eggert, C., Temp, U. & Eriksson, K. E. L. (1997) Laccase is essential for lignin degradation by the white-rot fungus *Pycnoporus cinnabarinus*. *Febs Letters*, 407, 89-92.
- Eggert, C., Lafayette, P. R., Temp, U., Eriksson, K. E. L. & Dean, J. F. D. (1998) Molecular analysis of a laccase gene from the white rot fungus *Pycnoporus cinnabarinus*. *Applied and Environmental Microbiology*, 64, 1766-1772.
- Enguita, F. J., Martins, L. O., Henriques, A. O. & Carrondo, M. A. (2003) Crystal structure of a bacterial endospore coat component - A laccase with enhanced thermostability properties. *Journal of Biological Chemistry*, 278, 19416-19425.
- Eriksson, K. E. & Pettersson, B. (1982) Purification and partial characterization of 2 acidic proteases from the white-rot fungus *Sporotrichum pulverulentum*. *European Journal of Biochemistry*, 124, 635-642.
- Eugenio, M. E., Carbajo, J. M., Martin, J. A., Gonzalez, A. E. & Villar, J. C. (2009) Laccase production by *Pycnoporus sanguineus* under different culture conditions. *Journal of Basic Microbiology*.
- Fahraeus, G., Tullander, V. & Ljunggren, H. (1958) Production of high laccase yields in cultures of fungi *Physiologia Plantarum*, 11, 631-643.
- Farnet, A. M., Tagger, S. & Le Petit, J. (1999) Effects of copper and aromatic inducers on the laccases of the white-rot fungus *Marasmius quercophilus*. *Comptes Rendus De L Academie Des Sciences Serie Iii-Sciences De La Vie-Life Sciences*, 322, 499-503.
- Farnet, A. M., Criquet, S., Tagger, S., Gil, G. & Le Petit, J. (2000) Purification, partial characterization, and reactivity with aromatic compounds of two laccases from *Marasmius quercophilus* strain 17. *Canadian Journal of Microbiology*, 46, 189-194.

- Fenice, M., Sermanni, G. G., Federici, F. & D'annibale, A. (2003) Submerged and solid-state production of laccase and Mn-peroxidase by *Panus tigrinus* on olive mill wastewater-based media. *Journal of Biotechnology*, 100, 77-85.
- Fernandez, E., Sanchez-Amat, A. & Solano, F. (1999) Location and catalytic characteristics of a multipotent bacterial polyphenol oxidase. *Pigment Cell Research*, 12, 331-339.
- Fernandezlarrea, J. & Stahl, U. (1996) Isolation and characterization of a laccase gene from *Podospora anserina*. *Molecular & General Genetics*, 252, 539-551.
- Fernando, T., Aust, S. D. & Bumpus, J. A. (1989) Effects of culture parameters on Ddt [1,1,1-Trichloro-2,2-Bis(4-Chlorophenyl)Ethane] biodegradation by *Phanerochaete-chrysosporium*. *Chemosphere*, 19, 1387-1398.
- Filazzola, M. T., Sannino, F., Rao, M. A. & Gianfreda, L. (1999) Effect of various pollutants and soil-like constituents on laccase from *Cerrena unicolor*. *Journal of Environmental Quality*, 28, 1929-1938.
- Fortina, M. G., Acquati, A., Rossi, P., Manachini, P. L. & Digennaro, C. (1996) Production of laccase by *Botrytis cinerea* and fermentation studies with strain F226. *Journal of Industrial Microbiology*, 17, 69-72.
- Francis, F., Sabu, A., Nampoothiri, K. M., Ramachandran, S., Ghosh, S., Szakacs, G. & Pandey, A. (2003) Use of response surface methodology for optimizing process parameters for the production of alpha-amylase by *Aspergillus oryzae*. *Biochemical Engineering Journal*, 15, 107-115.
- Fu, S. Y., Yu, H. S. & Buswell, J. A. (1997) Effect of nutrient nitrogen and manganese on manganese peroxidase and laccase production by *Pleurotus sajor-caju*. *Fems Microbiology Letters*, 147, 133-137.
- Fukushima, Y. & Kirk, T. K. (1995) Laccase component of the *Ceriporiopsis-subvemispora* lignin-degrading system. *Applied and Environmental Microbiology*, 61, 872-876.

- Furuhashi, K. & Takagi, M. (1984) Optimization of a medium for the production of 1,2-epoxytetradecane by *Nocardia-Corallina* B-276. *Applied Microbiology and Biotechnology*, 20, 6-9.
- Galhaup, C. & Haltrich, D. (2001) Enhanced formation of laccase activity by the white-rot fungus *Trametes pubescens* in the presence of copper. *Applied Microbiology and Biotechnology*, 56, 225-232.
- Galhaup, C., Goller, S., Peterbauer, C. K., Strauss, J. & Haltrich, D. (2002a) Characterization of the major laccase isoenzyme from *Trametes pubescens* and regulation of its synthesis by metal ions. *Microbiology*, 148, 2159-2169.
- Galhaup, C., Wagner, H., Hinterstoisser, B. & Haltrich, D. (2002b) Increased production of laccase by the wood-degrading basidiomycete *Trametes pubescens*. *Enzyme and Microbial Technology*, 30, 529-536.
- Garzillo, A. M. V., Colao, M. C., Caruso, C., Caporale, C., Celletti, D. & Buonocore, V. (1998) Laccase from the white-rot fungus *Trametes trogii*. *Applied Microbiology and Biotechnology*, 49, 545-551.
- Geng, X. & Li, K. (2002) Degradation of non-phenolic lignin by the white-rot fungus *Pycnoporus cinnabarinus*. *Applied Microbiology and Biotechnology*, 60, 342-346.
- Germann, U. A. & Lerch, K. (1986) Isolation and partial nucleotide sequence of the laccase gene from *Neurospora crassa*: amino acid sequence homology of the protein to human ceruloplasmin. *Proc Natl Acad Sci U S A*, 83, 8854-8858.
- Germann, U. A., Muller, G., Hunziker, P. E. & Lerch, K. (1988) Characterization of 2 allelic forms of *Neurospora crassa* laccase amino-terminal and carboxyl-terminal processing of a precursor. *Journal of Biological Chemistry*, 263, 885-896.
- Ghanem, N. B., Yusef, H. H. & Mahrouse, H. K. (2000) Production of *Aspergillus terreus* xylanase in solid-state cultures: application of the Plackett-Burman experimental design to evaluate nutritional requirements. *Bioresource Technology*, 73, 113-121.

- Gianfreda, L., Xu, F. & Bollag, J.-M. (1999) Laccases, a useful group of oxidoreductive enzymes. *Biorem. J*, 3, 1 - 26.
- Giardina, P., Palmieri, G., Scaloni, A., Fontanella, B., Faraco, V., Cennamo, G. & Sanna, G. (1999) Protein and gene structure of a blue laccase from *Pleurotus ostreatus*. *Biochemical Journal*, 341, 655-663.
- Gigi, O., Marbach, I. & Mayer, A. M. (1981) Properties of gallic acid induced extracellular laccase of *Botrytis cinerea*. *Phytochemistry*, 20, 1211-1213.
- Givaudan, A., Effosse, A., Faure, D., Potier, P., Bouillant, M. L. & Bally, R. (1993) polyphenol oxidase in *Azospirillum-Lipoferum* isolated from rice *Rhizosphere* - evidence for laccase activity in nonmotile strains of *Azospirillum lipoferum*. *Fems Microbiology Letters*, 108, 205-210.
- Guillen, F., Gomez-Toribio, V., Martinez, M. J. & Martinez, A. T. (2000) Production of hydroxyl radical by the synergistic action of fungal laccase and aryl alcohol oxidase. *Archives of Biochemistry and Biophysics*, 383, 142-147.
- Hamerski, D., Beier, R. C., Kneusel, R. E., Matern, U. & Himmelspach, K. (1990) accumulation of coumarins in elicitor-treated cell-suspension cultures of *Ammi-Majus*. *Phytochemistry*, 29, 1137-1142.
- Hardin, I. R., Cao, H., Wilson, S. S. & Akin, D. E. (2000) Decolorization of textile wastewater by selective fungi. *Textile Chemist and Colorist & American Dyestuff Reporter*, 32, 38-42.
- Harvey, L. M. & Mcneil, B. (1994) Liquid fermentation systems and product recovery of *Aspergillus*. IN Smith, J. E. (Ed.) *Biotechnology handbooks*, vol. 7, NewYork, Plenum, 142,158-166.
- Heinzkill, M., Bech, L., Halkier, T., Schneider, P. & Anke, T. (1998) Characterization of laccases and peroxidases from wood-rotting fungi (family *Coprinaceae*). *Applied and Environmental Microbiology*, 64, 1601-1606.
- Herpoël, I., Moukha, S., Lesage-Meessen, L., Sigoillot, J. C. & Asther, M. (2000) Selection of *Pycnoporus cinnabarinus* strains for laccase production. *Fems Microbiology Letters*, 183, 301-306.

- Hess, J., Leitner, C., Galhaup, C., Kulbe, K. D., Hinterstoisser, B., Steinwender, M. & Haltrich, D. (2002) Enhanced formation of extracellular laccase activity by the white-rot fungus *Trametes multicolor*. *Applied Biochemistry and Biotechnology*, 98, 229-241.
- Hofer, C. & Schlosser, D. (1999) Novel enzymatic oxidation of Mn^{2+} to Mn^{3+} catalyzed by a fungal laccase. *Febs Letters*, 451, 186-190.
- Hoopes, J. T. & Dean, J. F. D. (2004) Ferroxidase activity in a laccase-like multicopper oxidase from *Liriodendron tulipifera*. *Plant Physiology and Biochemistry*, 42, 27-33.
- Hublik, G. & Schinner, F. (2000) Characterization and immobilization of the laccase from *Pleurotus ostreatus* and its use for the continuous elimination of phenolic pollutants. *Enzyme and Microbial Technology*, 27, 330-336.
- Iimura, Y., Hartikainen, P. & Tatsumi, K. (1996) Dechlorination of tetrachloroguaiacol by laccase of white-rot basidiomycete *Coriolus versicolor*. *Applied Microbiology and Biotechnology*, 45, 434-439.
- Jaouani, A., Tabka, M. G., Sayadi, S., Vanthourhout, M. & Penninck, M. J. (2004) Potent fungi for olive oil mill wastewaters decolourisation. *International Biodeterioration & Biodegradation*, 53, 224.
- Jaouani, A., Tabka, M. G. & Penninckx, M. J. (2006) Lignin modifying enzymes of *Coriopsis polyzona* and their role in olive oil mill wastewaters decolourisation. *Chemosphere*, 62, 1421-1430.
- Johannes, C., Majcherczyk, A. & Huttermann, A. (1998) Oxidation of acenaphthene and acenaphthylene by laccase of *Trametes versicolor* in a laccase-mediator system. *Journal of Biotechnology*, 61, 151-156.
- Johannes, C. & Majcherczyk, A. (2000) Natural mediators in the oxidation of polycyclic aromatic hydrocarbons by laccase mediator systems. *Applied and Environmental Microbiology*, 66, 524-528.

- Johnson, D. L., Thompson, J. L., Brinkmann, S. M., Schuller, K. A. & Martin, L. L. (2003) Electrochemical characterization of purified *Rhus vernicifera* laccase: Voltammetric evidence for a sequential four-electron transfer. *Biochemistry*, 42, 10229-10237.
- Jolival, C., Raynal, A., Caminade, E., Kokel, B., Le Goffic, F. & Mougin, C. (1999) Transformation of N',N'-dimethyl-N-(hydroxyphenyl)ureas by laccase from the white rot fungus *Trametes versicolor*. *Applied Microbiology and Biotechnology*, 51, 676-681.
- Jönsson, L. J., Saloheimo, M. & Penttilä, M. (1997) Laccase from the white-rot fungus *Trametes versicolor*: cDNA cloning of *Icc1* and expression in *Pichia pastoris*. *Current Genetics*, 32, 425-430.
- Jung, H. C., Xu, F. & Li, K. C. (2002) Purification and characterization of laccase from wood-degrading fungus *Trichophyton rubrum* LKY-7. *Enzyme and Microbial Technology*, 30, 161-168.
- Junghanns, C., Moeder, M., Krauss, G., Martin, C. & Schlosser, D. (2005) Degradation of the xenoestrogen nonylphenol by aquatic fungi and their laccases. *Microbiology-Sgm*, 151, 45-57.
- Kahraman, S. S. & Gurdal, I. H. (2002) Effect of synthetic and natural culture media on laccase production by white rot fungi. *Bioresource Technology*, 82, 215-217.
- Keen, N. T. (1975) Specific elicitors of plant phytoalexin production - determinants of race specificity in pathogens. *Science*, 187, 74-75.
- Kiese, S., Ebner, H. G. & Onken, U. (1980) A simple laboratory airlift fermenter. *Biotechnology Letters*, 2, 345-350.
- Kiiskinen, L. L., Viikari, L. & Kruus, K. (2002) Purification and characterisation of a novel laccase from the ascomycete *Melanocarpus albomyces*. *Applied Microbiology and Biotechnology*, 59, 198-204.

- Kiiskinen, L. L. & Saloheimo, M. (2004) Molecular cloning and expression in *Saccharomyces cerevisiae* of a laccase gene from the ascomycete *Melanocarpus albomyces*. *Applied and Environmental Microbiology*, 70, 137-144.
- Kim, Y. H. & Yoo, Y. J. (1996) Peroxidase production from carrot hairy root cell culture. *Enzyme and Microbial Technology*, 18, 531-535.
- Ko, E. M., Leem, Y. E. & Choi, H. T. (2001) Purification and characterization of laccase isozymes from the white-rot basidiomycete *Ganoderma lucidum*. *Applied Microbiology and Biotechnology*, 57, 98-102.
- Kobayashi, T., Vandedem, G. & Moo-Young, M. (1973) Oxygen transfer into mycelial pellets. *Biotechnology and Bioengineering*, 15, 27-45.
- Kojima, Y., Tsukuda, Y., Kawai, Y., Tsukamoto, A., Sugiura, J., Sakaino, M. & Kita, Y. (1990) Cloning, sequence-analysis, and expression of ligninolytic phenoloxidase genes of the white-rot basidiomycete *Coriolus hirsutus*. *Journal of Biological Chemistry*, 265, 15224-15230.
- Kokol, V., Doliska, A., Eichlerova, I., Baldrian, P. & Nerud, F. (2007) Decolorization of textile dyes by whole cultures of *Ischnoderma resinsum* and by purified laccase and Mn-peroxidase. *Enzyme and microbial technology*, 40, 1673-1677.
- Koroleva, O. V., Gavrilova, V. P., Stepanova, E. V., Lebedeva, V. I., Sverdlova, N. I., Landesman, E. O., Yavmetdinov, I. S. & Yaropolov, A. I. (2001) Production of lignin modifying enzymes by co-cultivated white-Rot Fungi *Cerrena maxima* and *Coriolus hirsutus* and characterization of laccase from *Cerrena maxima*. *8th International Conference on Biotechnology in the Pulp and Paper Industry*. Helsinki, Finland, Elsevier Science Inc.
- Kumar, S. V. S., Phale, P. S., Durani, S. & Wangikar, P. P. (2003) Combined sequence and structure analysis of the fungal laccase family. *Biotechnology and Bioengineering*, 83, 386-394.

- Kumari, H. L. & Sirsi, M. (1972) Purification and properties of laccase from *Ganoderma-Lucidum*. *Archiv Fur Mikrobiologie*, 84, 350-&.
- Kurniawati, S. & Nicell, J. A. (2007) Efficacy of mediators for enhancing the laccase-catalyzed oxidation of aqueous phenol. *Enzyme and microbial technology*, 41, 353-361.
- Laemmli, U. K. (1970) Cleavage of structural proteins during assembly of head of bacteriophage-T4. *Nature*, 227, 680-&.
- Lante, A., Crapisi, A., Krastanov, A. & Spettoli, P. (2000) Biodegradation of phenols by laccase immobilised in a membrane reactor. *Process Biochemistry*, 36, 51-58.
- Lasonder, E., Ishihama, Y., Andersen, J. S., Vermunt, A. M. W., Pain, A., Sauerwein, R. W., Eling, W. M. C., Hall, N., Waters, A. P., Stunnenberg, H. G. & Mann, M. (2002) Analysis of the *Plasmodium falciparum* proteome by high-accuracy mass spectrometry. *Nature*, 419, 537-542.
- Leatham, G. F. & Kirk, T. K. (1983) Regulation of ligninolytic activity by nutrient nitrogen in white-rot basidiomycetes. *Fems Microbiology Letters*, 16, 65-67.
- Lee, H., Song, M. & Hwang, S. (2003) Optimizing bioconversion of deproteinated cheese whey to mycelia of *Ganoderma lucidum*. *Process Biochemistry*, 38, 1685-1693.
- Lee, I. Y., Jung, K. H., Lee, C. H. & Park, Y. H. (1999) Enhanced production of laccase in *Trametes vesicolor* by the addition of ethanol. *Biotechnology Letters*, 21, 965-968.
- Lee, K. M. & Gilmore, D. F. (2005) Formulation and process modeling of biopolymer (polyhydroxyalkanoates: PHAs) production from industrial wastes by novel crossed experimental design. *Process Biochemistry*, 40, 229-246.
- Lee, S. C. & West, C. A. (1981) Polygalacturonase from *Rhizopus-Stolonifer*, an elicitor of casbene synthetase-activity in castor bean (*Ricinus-Communis* L) seedlings. *Plant Physiology*, 67, 633-639.

- Lee, Y., Park, C., Lee, B., Han, E. J., Kim, T. H., Lee, J. & Kim, S. (2006) Effect of nutrients on the production of extracellular enzymes for decolorization of reactive blue 19 and reactive black 5. *Journal of Microbiology and Biotechnology*, 16, 226-231.
- Leem, Y. E., Kim, S. J., Ross, I. K. & Choi, H. T. (1999) Transformation and laccase mutant isolation in *Coprinus congregatus* by restriction enzyme-mediated integration. *Fems Microbiology Letters*, 172, 35-40.
- Leonowicz, A., Trojanow, J. & Nowak, G. (1972) Ferulic acid as inductor of messenger-RNA synthesis related to laccase formation in wood rotting fungus *Pleurotus ostreatus*. *Microbios*, 6, 23-28.
- Leonowicz, A., Szklarz, G. & Wojtaswasilewska, M. (1985) The effect of fungal laccase on fractionated lignosulphonates (Peritan Na). *Phytochemistry*, 24, 393-396.
- Leontievsky, A., Myasoedova, N., Pozdnyakova, N. & Golovleva, L. (1997) 'Yellow' laccase of *Panus tigrinus* oxidizes non-phenolic substrates without electron-transfer mediators. *Febs Letters*, 413, 446-448.
- Levin, L., Forchiassin, F. & Viale, A. (2005) Ligninolytic enzyme production and dye decolorization by *Trametes trogii*: application of the Plackett-Burman experimental design to evaluate nutritional requirements. *Process Biochemistry*, 40, 1381-1387.
- Li, K. C., Xu, F. & Eriksson, K. E. L. (1999) Comparison of fungal laccases and redox mediators in oxidation of a nonphenolic lignin model compound. *Applied and environmental microbiology*, 65, 2654-2660.
- Litvintseva, A. P. & Henson, J. M. (2002) Cloning, characterization, and transcription of three laccase genes from *Gaeumannomyces graminis* var. *tritici*, the take-all fungus. *Applied and Environmental Microbiology*, 68, 1305-1311.
- Liu, F., Li, W. Q., Ridgway, D., Gu, T. Y. & Moo-Young, M. (1998) Inhibition of extracellular protease secretion by *Aspergillus niger* using cell immobilization. *Biotechnology Letters*, 20, 539-542.

- Liu, L., Dean, J. F. D., Friedman, W. E. & Eriksson, K. E. L. (1994) A laccase-like phenoloxidase is correlated with lignin biosynthesis in zinnia-elegans stem tissues. *Plant Journal*, 6, 213-224.
- Lo, S. C., Ho, Y. S. & Buswell, J. A. (2001) Effect of phenolic monomers on the production of laccases by the edible mushroom *Pleurotus sajor-caju*, and partial characterization of a major laccase component. *Mycologia*, 93, 413-421.
- Lorenzo, M., Moldes, D., Couto, S. R. & Sanroman, A. (2002) Improving laccase production by employing different lignocellulosic wastes in submerged cultures of *Trametes versicolor*. *Bioresource Technology*, 82, PII S0960-8524(0901)00176-00176.
- Lorenzo, M., Moldes, D., Couto, S. R. & Sanroman, A. (2002) Improving laccase production by employing different lignocellulosic wastes in submerged cultures of *Trametes versicolor*. *Bioresource Technology*, 82, 109-113.
- Mai, C., Schormann, W., Milstein, O. & Huttermann, A. (2000) Enhanced stability of laccase in the presence of phenolic compounds. *Applied Microbiology and Biotechnology*, 54, 510-514.
- Majcherczyk, A., Johannes, C. & Huttermann, A. (1998) Oxidation of polycyclic aromatic hydrocarbons (PAH) by laccase of *Trametes versicolor*. *Enzyme and Microbial Technology*, 22, 335-341.
- Majcherczyk, A. & Johannes, C. (2000) Radical mediated indirect oxidation of a PEG-coupled polycyclic aromatic hydrocarbon (PAH) model compound by fungal laccase. *Biochimica Et Biophysica Acta-General Subjects*, 1474, 157-162.
- Malmström, B. G., Reinhammar, B. & Vanngård, T. (1970) The state of copper in stellacyanin and laccase from the lacquer tree *Rhus vernicifera*. *Biochim. Biophys. Acta.*, 205, 48-57.

- Mansur, M., Suarez, T., Fernandezlarrea, J. B., Brizuela, M. A. & Gonzalez, A. E. (1997) Identification of a laccase gene family in the new lignin-degrading basidiomycete CECT 20197. *Appl Environ Microbiol*, 63, 2637-2646.
- Mansur, M., Suarez, T., Fernandezlarrea, J. B., Brizuela, M. A. & Gonzalez, A. E. (1997) Identification of a laccase gene family in the new lignin-degrading basidiomycete CECT 20197. *Appl Environ Microbiol*, 63, 2637-2646.
- Mansur, M., Arias, M. E., Flardh, M. & Gonzalez, A. E. (2003) The white-rot fungus *Pleurotus ostreatus* secretes laccase isozymes with different substrate specificities. *Mycologia*, 95, 1013-1020.
- Manzanares, P., Fajardo, S. & Martin, C. (1995) Production of ligninolytic activities when treating paper pulp effluents by *Trametes versicolor*. *Journal of Biotechnology*, 43, 125-132.
- Marjasvaara, A., Janis, J. & Vainiotalo, P. (2008) Oxidation of a laccase mediator ABTS as studied by ESI-FTICR mass spectrometry. *Journal of Mass Spectrometry*, 43, 470-477.
- Martins, L. O., Soares, C. M., Pereira, M. M., Teixeira, M., Costa, T., Jones, G. H. & Henriques, A. O. (2002) Molecular and biochemical characterization of a highly stable bacterial laccase that occurs as a structural component of the *Bacillus subtilis* endospore coat. *Journal of Biological Chemistry*, 277, 18849-18859.
- Mayer, A. M. (1987) Polyphenol oxidases in plants - recent progress .2. *Phytochemistry*, 26, 11-20.
- Mayer, A. M. & Staples, R. C. (2002) Laccase: new functions for an old enzyme. *Phytochemistry*, 60, PII S0031-9422(0002)00171-00171.
- Medeiros, M. B., Bento, A. V., Nunes, A. L. L. & Oliveira, S. C. (1999) Optimization of some variables that affect the synthesis of laccase by *Pleurotus ostreatus*. *Bioprocess Engineering*, 21, 483-487.
- Metz, B. & Kossen, N. W. F. (1977) Growth of Molds in Form of Pellets - Literature-Review. *Biotechnology and Bioengineering*, 19, 781-799.

- Meza, J. C., Auria, R., Lomascolo, A., Sigoillot, J. C. & Casalat, L. (2007) Role of ethanol on growth, laccase production and protease activity in *Pycnoporus cinnabarinus* ss3. *Enzyme and Microbial Technology*, 41, 162-168.
- Michniewicz, A., Ullrich, R., Ledakowicz, S. & Hofrichter, M. (2006) The white-rot fungus *Cerrena unicolor* strain 137 produces two laccase isoforms with different physico-chemical and catalytic properties. *Applied Microbiology and Biotechnology*, 69, 682-688.
- Minussi, R. C., Pastore, G. M. & Duran, N. (2002) Potential applications of laccase in the food industry. *Trends in Food Science & Technology*, 13, 205-216.
- Mohana, S., Shrivastava, S., Divecha, J. & Madamwar, D. (2008) Response surface methodology for optimization of medium for decolorization of textile dye Direct Black 22 by a novel bacterial consortium. *Bioresource Technology*, 99, 562-569.
- Moldes, D., Lorenzo, M. & Sanroman, M. A. (2004) Different proportions of laccase isoenzymes produced by submerged cultures of *Trametes versicolor* grown on lignocellulosic wastes. *Biotechnology Letters*, 26, 327-330.
- Moo-Young, M., Moreira, A. R. & Tengerdy, R. P. (1983) The filamentous fungi. IN Smith, J. E., Berry, D. R. & Kristiansen, B. (Eds.), London, Edward Arnold Publishers, 117-144.
- Moredo, N., Lorenzo, M., Dominguez, A., Moldes, D., Cameselle, C. & Sanroman, A. (2003) Enhanced ligninolytic enzyme production and degrading capability of *Phanerochaete chrysosporium* and *Trametes versicolor*. *World Journal of Microbiology & Biotechnology*, 19, 665-669.
- Morgan, P., Lewis, S. T. & Watkinson, R. J. (1991) Comparison of abilities of white-rot fungi to mineralize selected xenobiotic compounds. *Applied Microbiology and Biotechnology*, 34, 693-696.
- Morozova, O. V., Shumakovich, G. P., Shleev, S. V. & Yaropolov, Y. I. (2007) Laccase-mediator systems and their applications: A review. *Applied Biochemistry and Microbiology*, 43, 523-535.

- Muñoz, C., Guillén, F., Martín, A. T. & Martín, M. J. (1997) Laccase isoenzymes of *Pleurotus eryngii*: Characterization, catalytic properties, and participation in activation of molecular oxygen and Mn²⁺ oxidation. *Applied and Environmental Microbiology*, 63, 2166-2174.
- Murugesan, K., Dhamija, A., Nam, I. H., Kim, Y. M. & Chang, Y. S. (2007) Decolorization of reactive black 5 by laccase: Optimization by response surface methodology. *Dyes and Pigments*, 75, 176-184.
- Myers, R. H., Montgomery, D. C. & Anderson-Cook, C. M. (2002) *Response surface methodology: process and product optimization using designed experiments*, USA, Wiley.
- Nagarajan, G. (1999) Biodegradation of reactive dye (Verofix Red) by the white-rot fungus *Phanerochaete chrysosporium* using Box-Behnken experimental design. *Bioprocess engineering*, 20, 435-440.
- Nikupaavola, M. L., Karhunen, E., Salola, P. & Raunio, V. (1988) Ligninolytic Enzymes of the White-Rot Fungus *Phlebia-Radiata*. *Biochemical Journal*, 254, 877-883.
- Nyanhongo, G. S., Gomes, J., Gubitz, G., Zvauya, R., Read, J. S. & Steiner, W. (2002) Production of laccase by a newly isolated strain of *Trametes modesta*. *Bioresource Technology*, 84, 259-263.
- Nyanhongo, G. S., Gomes, J., Gubitz, G. M., Zvauya, R., Read, J. & Steiner, W. (2002) Decolorization of textile dyes by laccases from a newly isolated strain of *Trametes modesta*. *Water Res*, 36, 1449-1456.
- Oh, S., Rheem, S., Sim, J., Kim, S. & Baek, Y. (1995) Optimizing conditions for the growth of *Lactobacillus casei* Yit-9018 in tryptone-yeast extract-glucose medium by using response-surface methodology. *Applied and Environmental Microbiology*, 61, 3809-3814.
- Olivieri, G., Marzocchella, A., Salatino, P., Giardina, P., Cennamo, G. & Sannia, G. (2006) Olive mill wastewater remediation by means of *Pleurotus ostreatus*. *Biochemical Engineering Journal*, 31, 180-187.

- Paice, M. G., Bourbonnais, R., Reid, I. D., Archibald, F. S. & Jurasek, L. (1995) Oxidative bleaching enzymes - a review. *Journal of Pulp and Paper Science*, 21, J280-J284.
- Palmieri, G., Giardina, P., Marzullo, L., Desiderio, B., Nitti, G., Cannio, R. & Sannia, G. (1993) Stability and activity of a phenol oxidase from the ligninolytic fungus *Pleurotus ostreatus*. *Applied Microbiology and Biotechnology*, 39, 632-636.
- Palmieri, G., Giardina, P., Bianco, C., Scaloni, A., Capasso, A. & Sannia, G. (1997) A novel white laccase from *Pleurotus ostreatus*. *Journal of Biological Chemistry*, 272, 31301-31307.
- Palmieri, G., Giardina, P., Bianco, C., Fontanella, B. & Sannia, G. (2000) Copper induction of laccase isoenzymes in the ligninolytic fungus *Pleurotus ostreatus*. *Applied and Environmental Microbiology*, 66, 920-924.
- Palmieri, G., Bianco, C., Cennamo, G., Giardina, P., Marino, G., Monti, M. & Sannia, G. (2001) Purification, characterization, and functional role of a novel extracellular protease from *Pleurotus ostreatus*. *Applied and Environmental Microbiology*, 67, 2754-2759.
- Palmieri, G., Cennamo, G., Faraco, V., Amoresano, A., Sannia, G. & Giardina, P. (2003) Atypical laccase isoenzymes from copper supplemented *Pleurotus ostreatus* cultures. *Enzyme and Microbial Technology*, 33, 220-230.
- Palmqvist, E. & Hahn-Hagerdal, B. (2000) Fermentation of lignocellulosic hydrolysates. I: inhibition and detoxification. *Bioresource Technology*, 74, 17-24.
- Park, C., Lee, B., Han, E. J., Lee, J. & Kim, S. (2006) Decolorization of acid black 52 by fungal immobilization. *Enzyme and Microbial Technology*, 39, 371-374.
- Parra, R., Aldred, D. & Magan, N. (2005) Medium optimization for the production of the secondary metabolite squalenolone S1 by a *Phoma* sp combining orthogonal design and response surface methodology. *Enzyme and Microbial Technology*, 37, 704-711.

- Parra, R., Aldred, D. & Magan, N. (2005) A novel immobilised design for the production of the heterologous protein lysozyme by a genetically engineered *Aspergillus niger* strain. *Applied Microbiology and Biotechnology*, 67, 336-344.
- Perry, C. R., Matcham, S. E., Wood, D. A. & Thurston, C. F. (1993) The Structure of Laccase Protein and Its Synthesis by the Commercial Mushroom *Agaricus-Bisporus*. *Journal of General Microbiology*, 139, 171-178.
- Petruccioli, M., Federici, F., Bucke, C. & Keshavarz, T. (1999) Enhancement of glucose oxidase production by *Penicillium variabile* P16. *Enzyme and Microbial Technology*, 24, 397-401.
- Piscitelli, A., Giardina, P., Mazzoni, C. & Sannia, G. (2005) Recombinant expression of *Pleurotus ostreatus* laccases in *Kluyveromyces lactis* and *Saccharomyces cerevisiae*. *Applied Microbiology and Biotechnology*, 69, 428-439.
- Plackett, R. L. & Burman, J. P. (1946) The design of optimum multifactorial experiments. *Biometrika*, 305-325.
- Pointing, S. B., Jones, E. B. G. & Vrijmoed, L. L. P. (2000) Optimization of laccase production by *Pycnoporus sanguineus* in submerged liquid culture. *Mycologia*, 92, 139-144.
- Pozdniakova, N. N., Turkovskaia, O. V., Iudina, E. N. & Rodakiewicz-Nowak, Y. (2006) Yellow laccase from the fungus *Pleurotus ostreatus* D1: purification and characterization. *Prikl Biokhim Mikrobiol*, 42, 63-69.
- Prapulla, S. G., Jacob, Z., Chand, N., Rajalakshmi, D. & Karanth, N. G. (1992) Maximization of lipid production by *Rhodotorula gracilis* Cfr-1 using response-surface methodology. *Biotechnology and Bioengineering*, 40, 965-970.
- Quarantino, D., Ciaffi, M., Federici, E. & D'annibale, A. (2008) Response surface methodology study of laccase production in *Panus tigrinus* liquid cultures. *Biochemical Engineering Journal*, 39, 236-245.

- Radman, R. (2002) Study of the effects of oligosaccharides in liquid cultures of *Penicillium chrysogenum*. PhD thesis *School of Biosciences*. London, University of Westminster
- Radman, R., Saez, T., Bucke, C. & Keshavarz, T. (2003) Elicitation of plants and microbial cell systems. *Biotechnology and Applied Biochemistry*, 37, 91-102.
- Radman, R., Bucke, C. & Keshavarz, T. (2004) Elicitor effects on *Penicillium chrysogenum* morphology in submerged cultures. *Biotechnology and Applied Biochemistry*, 40, 229-233.
- Rancano, G., Lorenzo, M., Molares, N., Couto, S. R. & Sanroman, M. A. (2003) Production of laccase by *Trametes versicolor* in an airlift fermentor. *Process Biochemistry*, 39, 467-473.
- Record, E., Punt, P. J., Chamkha, M., Labat, M., Van Den Hondel, C. & Asther, M. (2002) Expression of the *Pycnoporus cinnabarinus* laccase gene in *Aspergillus niger* and characterization of the recombinant enzyme. *European Journal of Biochemistry*, 269, 602-609.
- Reid, I. D. & Paice, M. G. (1994) Biological Bleaching of kraft pulps by white-rot fungi and their enzymes. *FEMS Symposium on Lignin Biodegradation and Transformation*. Lisbon, Portugal, Elsevier Science Bv.
- Reyes, P., Pickard, M. A. & Vazquez-Duhalt, R. (1999) Hydroxybenzotriazole increases the range of textile dyes decolorized by immobilized laccase. *Biotechnology Letters*, 21, 875-880.
- Rigas, F. & Dritsa, V. (2006) Decolourisation of a polymeric dye by selected fungal strains in liquid cultures. *Enzyme and microbial technology*, 39, 120-124.
- Robinson, T., McMullan, G., Marchant, R. & Nigam, P. (2001) Remediation of dyes in textile effluent: a critical review on current treatment technologies with a proposed alternative. *Bioresource Technology*, 77, 247-255.

- Rodriguez Couto, S., Sanroman, M. A., Hofer, D. & Gubitz, G. M. (2004) Stainless steel sponge: a novel carrier for the immobilisation of the white-rot fungus *Trametes hirsuta* for decolourization of textile dyes. *Bioresour Technol*, 95, 67-72.
- Rodriguez Couto, S., Rodriguez, A., Paterson, R. R. M., Lima, N. & Teixeira, J. A. (2006) Laccase activity from the fungus *Trametes hirsuta* using an air-lift bioreactor. *Lett Appl Microbiol*, 42, 612-616.
- Rogalski, J., Dawidowicz, A. L. & Leonowicz, A. (1990) Purification and immobilization of the inducible form of extracellular laccase of the fungus *Trametes versicolor*. *Acta Biotechnologica*, 10, 261-269.
- Rogalski, J., Lundell, T., Leonowicz, A. & Hatakka, A. (1991) Production of laccase, lignin peroxidase and manganese-dependent peroxidase by various strains of *Trametes versicolor* depending on culture conditions. *Acta Microbiologica Polonica*, 40, 221-234.
- Rogalski, J., Lundell, T. K., Leonowicz, A. & Hatakka, A. I. (1991) Influence of aromatic-compounds and lignin on production of ligninolytic enzymes by *Phlebia radiata*. *Phytochemistry*, 30, 2869-2872.
- Ronne, H. (1995) Glucose Repression in fungi. *Trends in Genetics*, 11, 12-17.
- Roriz, M. S., Osma, J. F., Teixeira, J. A. & Rodriguez Couto, S. (2009) Application of response surface methodological approach to optimise Reactive Black 5 decolouration by crude laccase from *Trametes pubescens*. *Journal of Hazardous Materials*, In Press, Corrected Proof.
- Rosales, E., Couto, S. R. & Sanroman, M. A. (2007) Increased laccase production by *Trametes hirsuta* grown on ground orange peelings. *Enzyme and Microbial Technology*, 40, 1286-1290.
- Ruijter, G. J. G. & Visser, J. (1997) Carbon repression in *Aspergilli*. *Fems Microbiology Letters*, 151, 103-114.

- Ryan, D. R., Leukes, W. D. & Burton, S. G. (2005) Fungal bioremediation of phenolic wastewaters in an airlift reactor. *Biotechnology Progress*, 21, 1068-1074.
- Saloheimo, M., Nikupaavola, M. L. & Knowles, J. K. C. (1991) Isolation and structural analysis of the laccase gene from the lignin-degrading fungus *Phlebia radiata*. *Journal of General Microbiology*, 137, 1537-1544.
- Sanchez-Amat, A., Lucas-Elio, P., Fernandez, E., Garcia-Borrón, J. C. & Solano, F. (2001) Molecular cloning and functional characterization of a unique multipotent polyphenol oxidase from *Marinomonas mediterranea*. *Biochimica Et Biophysica Acta-Protein Structure and Molecular Enzymology*, 1547, 104-116.
- Sandhu, D. K. & Arora, D. S. (1984) Laccase production by *Polyporus versicolor* on Different Substrates. *Acta Biotechnologica*, 4, 49-57.
- Sannia, G., Giardina, P., Luna, M., Rossi, M. & Buonocore, V. (1986) Laccase from *Pleurotus Ostreatus*. *Biotechnology Letters*, 8, 797-800.
- Saparrat, M. C. N., Guillen, F., Arambarri, A. M., Martinez, A. T. & Martinez, M. J. (2002) Induction, isolation, and characterization of two laccases from the white rot basidiomycete *Coriolopsis rigida*. *Applied and Environmental Microbiology*, 68, 1534-1540.
- Schliephake, K., Mainwaring, D. E., Lonergan, G. T., Jones, I. K. & Baker, W. L. (2000) Transformation and degradation of the disazo dye Chicago Sky Blue by a purified laccase from *Pycnoporus cinnabarinus*. *Enzyme and Microbial Technology*, 27, 100-107.
- Schlosser, D., Grey, R. & Fritsche, W. (1997) Patterns of ligninolytic enzymes in *Trametes versicolor* distribution of extra- and intracellular enzyme activities during cultivation on glucose, wheat straw and beech wood. *Applied Microbiology and Biotechnology*, 47, 412-418.

- Schneider, P., Caspersen, M. B., Mondorf, K., Halkier, T., Skov, L. K., Østergaard, P. R., Brown, K. M., Brown, S. H. & Xu, F. (2000) Characterization of a *Coprinus cinereus* laccase (vol 25, pg 502, 1999). *Enzyme and Microbial Technology*, 26, 311-311.
- Shaul, G. M., Holdsworth, T. J., Dempsey, C. R. & Dostal, K. A. (1991) Fate of Water-Soluble Azo Dyes in the Activated-Sludge Process. *Chemosphere*, 22, 107-119.
- Shin, M., Nguyen, T. & Ramsay, J. (2002) Evaluation of support materials for the surface immobilization and decoloration of amaranth by *Trametes versicolor*. *Applied Microbiology and Biotechnology*, 60, 218-223.
- Shleev, S., Nikitina, O., Christenson, A., Reimann, C. T., Yaropolov, A. I., Ruzgas, T. & Gorton, L. (2007) Characterization of two new multiforms of *Trametes pubescens* laccase. *Bioorganic Chemistry*, 35, 35-49.
- Shleev, S. V., Morozova, O., Nikitina, O., Gorshina, E. S., Rusinova, T., Serezhenkov, V. A., Burbaev, D. S., Gazaryan, I. G. & Yaropolov, A. I. (2004) Comparison of physico-chemical characteristics of four laccases from different basidiomycetes. *Biochimie*, 86, 693-703.
- Slomczynski, D., Nakas, J. P. & Tanenbaum, S. W. (1995) Production and characterization of laccase from *Botrytis cinerea*-61-34. *Applied and Environmental Microbiology*, 61, 907-912.
- Smirnov, S. A., Koroleva, O. V., Gavrilova, V. P., Belova, A. B. & Klyachko, N. L. (2001) Laccases from basidiomycetes: Physicochemical characteristics and substrate specificity towards methoxyphenolic compounds. *Biochemistry-Moscow*, 66, 774-779.
- Soares, G. M. B., De Amorim, M. T. P. & Costa-Ferreira, M. (2001) Use of laccase together with redox mediators to decolourize Remazol Brilliant Blue R. *J Biotechnol*, 89, 123-129.
- Soares, G. M. B., Amorim, M. T. P., Hrdina, R. & Costa-Ferreira, M. (2002) Studies on the biotransformation of novel disazo dyes by laccase. *Process*

- Biochemistry*, 37, 581-587.
- Soden, D. M. & Dobson, A. D. W. (2001) Differential regulation of laccase gene expression in *Pleurotus sajor-caju*. *Microbiology-Sgm*, 147, 1755-1763.
- Soden, D. M., O'callaghan, J. & Dobson, A. D. W. (2002) Molecular cloning of a laccase isozyme gene from *Pleurotus sajor-caju* and expression in the heterologous *Pichia pastoris* host. *Microbiology-Sgm*, 148, 4003-4014.
- Spadaro, J. T., Gold, M. H. & Renganathan, V. (1992) Degradation of azo dyes by the lignin-degrading fungus *Phanerochaete chrysosporium*. *Applied and environmental microbiology*, 58, 2397-2401.
- Srinivasan, C., Dsouza, T. M., Boominathan, K. & Reddy, C. A. (1995) Demonstration of laccase in the white-rot basidiomycete *Phanerochaete chrysosporium* Bkm-F1767. *Applied and Environmental Microbiology*, 61, 4274-4277.
- Stajic, M., Persky, L., Friesem, D., Hadar, Y., Wasser, S. P., Nevo, E. & Vukojevic, J. (2006) Effect of different carbon and nitrogen sources on laccase and peroxidases production by selected *Pleurotus* species. *Enzyme and Microbial Technology*, 38, 65-73.
- Staszczak, M., Zdunek, E. & Leonowicz, A. (2000) Studies on the role of proteases in the white-rot fungus *Trametes versicolor*: Effect of PMSF and chloroquine on ligninolytic enzymes activity. *Journal of Basic Microbiology*, 40, 51-63.
- Sterjiades, R., Dean, J. F. D. & Eriksson, K. E. L. (1992) Laccase from sycamore maple (*Acer-Pseudoplatanus*) polymerizes monolignols. *Plant Physiology*, 99, 1162-1168.
- Swamy, J. & Ramsay, J. A. (1999) Effects of Mn^{2+} and NH_4^+ concentrations on laccase and manganese peroxidase production and amaranth decoloration by *Trametes versicolor*. *Appl Microbiol Biotechnol*, 51, 391-396.
- Tamerler, C., Ariyo, B., Bucke, C. & Keshavarz, T. (2001) Effect of mannan and alginate oligosaccharides on production in bioreactors of penicillin G and its biosynthetic intermediates. *Annals of Microbiology*, 51, 53-60.

- Tauber, M. M., Gübitz, G. M. & Rehorek, A. (2008) Degradation of azo dyes by oxidative processes - laccase and ultrasound treatment. *Bioresource Technology*, 99, 4213-4220.
- Tavares, A. P. A., Coelho, M. A. Z., Agapito, M. S. M., Coutinho, J. A. P. & Xavier, A. (2006) Optimization and modeling of laccase production by *Trametes versicolor* in a bioreactor using statistical experimental design. *Applied Biochemistry and Biotechnology*, 134, 233-248.
- Tavares, A. P. M., Coelho, M. A. Z., Coutinho, J. A. P. & Xavier, A. (2005) Laccase improvement in submerged cultivation: induced production and kinetic modelling. *Journal of Chemical Technology and Biotechnology*, 80, 669-676.
- Teerapatsakul, C., Parra, R., Bucke, C. & Chitradon, L. (2007) Improvement of laccase production from *Ganoderma* sp KU-Alk4 by medium engineering. *World Journal of Microbiology & Biotechnology*, 23, 1519-1527.
- Tekere, M., Zvauya, R. & Read, J. S. (2001) Ligninolytic enzyme production in selected sub-tropical white rot fungi under different culture conditions. *Journal of Basic Microbiology*, 41, 115-129.
- Thakker, G. D., Evans, C. S. & Rao, K. K. (1992) Purification and characterization of laccase from *Monocillium-Indicum Saxena*. *Applied Microbiology and Biotechnology*, 37, 321-323.
- Thayer, D. W., Muller, W. S., Buchanan, R. L. & Phillips, J. G. (1987) Effect of NaCl, pH, temperature, and atmosphere on growth of *Salmonella-Typhimurium* in glucose-mineral salts medium. *Applied and Environmental Microbiology*, 53, 1311-1315.
- Thiruchelvam, A. T. & Ramsay, J. A. (2007) Growth and laccase production kinetics of *Trametes versicolor* in a stirred tank reactor. *Applied Microbiology and Biotechnology*, 74, 547-554.
- Thongchul, N. & Yang, S. T. (2003) Controlling filamentous fungal morphology by immobilization on a rotating fibrous matrix to enhance oxygen transfer and L(+)-lactic acid production by *Rhizopus oryzae*. *Fermentation Biotechnology*,

- 862, 36-51.
- Thurston, C. F. (1994) The Structure and function of fungal laccases. *Microbiology-Sgm*, 140, 19-26.
- Torres, E., Bustos-Jaimes, I. & Le Borgne, S. (2003) Potential use of oxidative enzymes for the detoxification of organic pollutants. *Applied Catalysis B-Environmental*, 46, 1-15.
- Trinder, P. (1969) Determination of blood glucose using an oxidase-peroxidase system with a non-carcinogenic chromogen. *Journal of Clinical Pathology*, 22, 158-&.
- Trovaslet, M., Enaud, E., Guiavarc'h, Y., Corbisier, A. M. & Vanhulle, S. (2007) Potential of a *Pycnoporus sanguineus* laccase in bioremediation of wastewater and kinetic activation in the presence of an anthraquinonic acid dye. *Enzyme and Microbial Technology*, 41, 368-376.
- Trupkin, S., Levin, L., Forchiassin, F. & Viale, A. (2003) Optimization of a culture medium for ligninolytic enzyme production and synthetic dye decolorization using response surface methodology. *Journal of Industrial Microbiology & Biotechnology*, 30, 682-690.
- Tsujimura, H., Takaya, M., Katano, K., Matsumoto, N., Park, Y. S. & Okabe, M. (1994) Peroxidase production by carbon and nitrogen-sources fed-batch culture of *Arthromyces ramosus*. *Biotechnology Letters*, 16, 575-580.
- Vandertol-Vanier, H. A., Vazquez-Duhalt, R., Tinoco, R. & Pickard, M. A. (2002) Enhanced activity by poly(ethylene glycol) modification of *Corioloropsis gallica* laccase. *Journal of Industrial Microbiology & Biotechnology*, 29, 214-220.
- Vanhulle, S., Radman, R., Parra, R., Cui, T. T., Bols, C. M., Tron, T., Sannia, G. & Keshavarz, T. (2007) Effect of mannan oligosaccharide elicitor and ferulic acid on enhancement of laccases production in liquid cultures of basidiomycetes. *Enzyme and Microbial Technology*, 40, 1712-1718.
- Vanhulle, S., Enaud, E., Trovaslet, M., Billottet, L., Kneipe, L., Jiwan, J. L. H.,

- Corbisier, A. M. & Marchand-Brynaert, J. (2008) Coupling occurs before breakdown during biotransformation of Acid Blue 62 by white rot fungi. *Chemosphere*, 70, 1097-1107.
- Vanhulle, S., Trovaslet, M., Enaud, E., Lucas, M., Sonveaux, M., Decock, C., Onderwater, R., Schneider, Y. J. & Corbisier, A. M. (2008) Cytotoxicity and genotoxicity evolution during decolorization of dyes by White Rot Fungi. *World Journal of Microbiology & Biotechnology*, 24, 337-344.
- Vassilev, N. & Vassileva, M. (1992) Production of organic-acids by immobilized filamentous fungi. *Mycological Research*, 96, 563-570.
- Vecht-Lifshitz, S. E., Magdassi, S. & Braun, S. (1990) Pellet formation and cellular aggregation in streptomyces tendae. *Biotechnology and Bioengineering*, 35, 890-896.
- Vohra, A. & Satyanarayana, T. (2002) Statistical optimization of the medium components by response surface methodology to enhance phytase production by *Pichia anomala*. *Process Biochemistry*, 37, 999-1004.
- Wang, L. P., Ridgway, D., Gu, T. Y. & Moo-Young, M. (2005) Bioprocessing strategies to improve heterologous protein production in filamentous fungal fermentations. *Biotechnology Advances*, 23, 115-129.
- Wesenberg, D., Kyriakides, I. & Agathos, S. N. (2003) White-rot fungi and their enzymes for the treatment of industrial dye effluents. *Biotechnology Advances*, 22, 161-187.
- Wesenberg, D., Kyriakides, I., Agathos, S.N. (2003) White-rot fungi and their enzymes for the treatment of industrial dye effluents. *Biotechnology Advances*, 22, 161-187.
- West, C. A. (1981) Fungal elicitors of the phytoalexin response in higher-plants. *Naturwissenschaften*, 68, 447-457.
- Wong, Y. X. & Yu, J. (1999) Laccase-catalyzed decolorization of synthetic dyes. *Water Res*, 33, 3512-3520.

- Woolery, G. L., Powers, L., Peisach, J. & Spiro, T. G. (1984) X-Ray absorption study of *Rhus* laccase - evidence for a copper copper interaction, which disappears on type-2 copper removal. *Biochemistry*, 23, 3428-3434.
- Xu, F. (1996) Oxidation of phenols, anilines, and benzenethiols by fungal laccases: Correlation between activity and redox potentials as well as halide inhibition. *Biochemistry*, 35, 7608-7614.
- Xu, F. (1997) Effects of redox potential and hydroxide inhibition on the pH activity profile of fungal laccases. *Journal of Biological Chemistry*, 272, 924-928.
- Xu, F., Berka, R. M., Wahleithner, J. A., Nelson, B. A., Shuster, J. R., Brown, S. H., Palmer, A. E. & Solomon, E. I. (1998) Site-directed mutations in fungal laccase: effect on redox potential, activity and pH profile. *Biochemical Journal*, 334, 63-70.
- Xu, F. (1999) Recent progress in laccase study: properties, enzymology, production and applications. IN Flickinger, M. C. & Drew, S. W. (Eds.) *The encyclopedia of bioprocessing technology: fermentation, biocatalysis and bioseparation* New York, Wiley.
- Yaver, D. S., Xu, F., Golightly, E. J., Brown, K. M., Brown, S. H., Rey, M. W., Schneider, P., Halkier, T., Mondorf, K. & Dalboge, H. (1996) Purification, characterization, molecular cloning, and expression of two laccase genes from the white rot basidiomycete *Trametes villosa*. *Applied and Environmental Microbiology*, 62, 834-841.
- Yoshitake, A., Katayama, Y., Nakamura, M., Iimura, Y., Kawai, S. & Morohoshi, N. (1993) N-linked carbohydrate chains protect laccase-III from proteolysis in *Coriolus versicolor*. *Journal of General Microbiology*, 139, 179-185.
- Zapanta, L. S. & Tien, M. (1997) The roles of veratryl alcohol and oxalate in fungal lignin degradation. *Journal of Biotechnology*, 53, 93-102.