



University of Warwick institutional repository: <http://go.warwick.ac.uk/wrap>

A Thesis Submitted for the Degree of PhD at the University of Warwick

<http://go.warwick.ac.uk/wrap/2784>

This thesis is made available online and is protected by original copyright.

Please scroll down to view the document itself.

Please refer to the repository record for this item for information to help you to cite it. Our policy information is available from the repository home page.

CAPACITY ACCESS IN
TELECOMMUNICATION NETWORKS:
EVALUATING THE SYMMETRY OF
COST-BASED ACCESS PRICES USING
OPTION PRICING THEORY

by

MICHAEL P.O. ORARO

A Thesis Submitted in Partial Fulfilment of
the Requirements for the Degree of
Doctor of Philosophy

WARWICK BUSINESS SCHOOL
UNIVERSITY OF WARWICK

AUGUST 2009

To my parents, George and Christina Oraro, who cared and provided, and made it possible for humble beginnings to open up to all that followed, is this thesis dedicated.

TABLE OF CONTENTS

LIST OF FIGURES	v
LIST OF TABLES	vi
ACKNOWLEDGMENTS	vii
DECLARATION	viii
ABSTRACT	ix
ABBREVIATIONS	x
CHAPTER 1. INTRODUCTION	1
1.1. Background	1
1.2. Motivation and Research Questions	4
1.3. Contributions and Limitations	6
1.4. Organization of Thesis	9
CHAPTER 2. MANDATORY UNBUNDLING AND ACCESS PRICING	11
2.1. Introduction	11
2.2. Vertical Integration and its Competitive Effects	13
2.3. Ex-ante Regulation and Mandatory Unbundling	16
2.3.1. Unbundling: Rationale	16
2.3.2. Unbundling and Service Penetration	17
2.4. Ex-ante Regulation and Vertical Separation	23
2.5. Ex-ante Regulation and Pricing Access	25
2.5.1. Rate-of-Return Regulation	25
2.5.2. The Efficient Component Pricing Rule	27
2.5.3. Price-cap Regulation	30
2.5.4. Cost-based Regulation	32
2.6. Access Pricing and Value of Flexibility	34
2.6.1. Value of Flexibility	34
2.6.2. Situating the Research Questions	40
2.7. This Thesis	43

TABLE OF CONTENTS—*Continued*

CHAPTER 3. OPTION PRICING THEORY	46
3.1. Introduction	46
3.2. Hedging by Dynamic Replication	48
3.3. Martingale Pricing	51
3.4. Applied Martingale Pricing	54
3.5. Contingent Claims on Defaultable Bonds	63
3.6. Summary	66
CHAPTER 4. RESEARCH DESIGN AND ANALYTICAL FRAMEWORK	67
4.1. Introduction	67
4.2. Philosophical Foundations	68
4.2.1. Positivism	68
4.2.2. Challenging Positivism	69
4.2.3. Hypothetico-Deductive Method	72
4.3. Research Design	74
4.3.1. Case Study Research	74
4.3.2. Structure of the Study and Data Sources	76
4.4. Monte Carlo Simulation	78
4.4.1. Basis as a Numerical Method	78
4.4.2. Simulating the SDEs Defining Value	81
4.5. Variance Reduction Techniques	85
4.5.1. General	85
4.5.2. Antithetic Variates	86
4.5.3. Control Variates	88
4.5.4. Other Variance Reduction Techniques	90
4.5.5. Low Discrepancy Sequences	92
4.6. Closed-Form Analytical Solutions	94
4.7. Summary	96
CHAPTER 5. ANALOGUE CAPACITY ACCESS: CONTINGENT CLAIM	
ANALYSIS	98
5.1. Introduction	98
5.2. Network Topology	99
5.2.1. Subscriber Access Network	99
5.2.2. Conveyance Network: Switching Layer	101
5.2.3. Conveyance Network: Transport Layer	103

TABLE OF CONTENTS—*Continued*

5.3.	Model Specification	105
5.3.1.	Downstream Value	105
5.3.2.	Traffic and Tariffs	107
5.4.	Access Layer and Conveyance	109
5.5.	Intensity of Line Activation	111
5.5.1.	Intensity in Equilibrium	111
5.5.2.	Dynamic Intensity	117
5.6.	Model Calibration	120
5.7.	Valuation	123
5.8.	Summary	128

CHAPTER 6. ADSL CAPACITY ACCESS: CONTINGENT CLAIM ANALY-

SIS	130	
6.1.	Introduction	130
6.2.	Network Topology	131
6.2.1.	Downstream and Upstream Markets	131
6.2.2.	Network Structure	133
6.3.	Model Specification	137
6.3.1.	General	137
6.3.2.	Downstream Value	138
6.3.3.	Tariffs and Downstream Value	140
6.4.	Intensity of Exchange Line Activation	143
6.4.1.	Intensity in Equilibrium	143
6.4.2.	Dynamic Intensity	146
6.5.	Access Layer and Conveyance	148
6.6.	Model Calibration	149
6.7.	Valuation	151
6.8.	Summary	152

CHAPTER 7. ACCESS PRICING: OPTION-THEORETIC ANALYTICAL GEN-

ERALIZATIONS	154	
7.1.	Introduction	154
7.2.	Analogue : Closed-form Analytical Generalizations	155
7.3.	ADSL : Closed-form Analytical Generalizations	161
7.4.	Summary	167

TABLE OF CONTENTS—*Continued*

CHAPTER 8. RESULTS AND DISCUSSION	168
8.1. Introduction	168
8.2. Results: Analogue	169
8.3. Results: ADSL	172
8.4. Discussion	175
8.5. Summary	181
CHAPTER 9. CONCLUSION	188
APPENDIX A. MRP: PROOFS	196
APPENDIX B. RENEWAL THEORY: PROOFS	199
APPENDIX C. ANALOGUE: MATLAB CODES	202
C.1. M-File I: $S_a(t)$ Process	202
C.2. M-File II: Line Activation	203
C.3. M-File III: Contingent Claim Valuation	204
C.4. M-File IV: Parameter Estimation - $S_a(t)$	205
C.5. M-File V: Parameter Estimation - $\rho_a(t)$	206
APPENDIX D. ADSL: MATLAB CODES	207
D.1. M-File I: $S_b(t)$ Process	207
D.2. M-File II: Line Activation	208
D.3. M-File III: Contingent Claim Valuation	208
D.4. M-File IV: Parameter Estimation - $S_b(t)$	210
APPENDIX E. DATA	211
APPENDIX F. ADSL: DISTRIBUTION OF EXCHANGE LINES	220
BIBLIOGRAPHY	222

LIST OF FIGURES

FIGURE 5.1.	Analogue - Network Topology	100
FIGURE 5.2.	Conveyance Infrastructure	102
FIGURE 6.1.	DSL - Subscriber Line	134
FIGURE 6.2.	Subscriber Access Network	135
FIGURE 6.3.	Capacity Access	136
FIGURE 8.1.	Analogue - Traffic (Raw Data and Fitted Curves)	181
FIGURE F.1.	Local Exchanges by Size	220
FIGURE F.2.	ADSL and Cable Overlap	221

LIST OF TABLES

TABLE 8.1.	Analogue - Seasonality (Parameter Estimates)	182
TABLE 8.2.	Analogue - Seasonality (Goodness of Fit)	182
TABLE 8.3.	Analogue - Downstream Value (Mean-reversion Parameters)	183
TABLE 8.4.	Analogue - Summary of Results (Numerical Methods) . . .	183
TABLE 8.5.	Analogue - Summary of Results (Analytical Methods) . . .	184
TABLE 8.6.	Analogue - Sensitivity Analysis (Scenario II)	184
TABLE 8.7.	Analogue - Summary of Results, Numerical Methods (With Perturbation)	185
TABLE 8.8.	ADSL - Summary of Results, Numerical Methods (Scenario I)	185
TABLE 8.9.	ADSL - Summary of Results, Scenario I (Analytical Methods)	186
TABLE 8.10.	ADSL - Sensitivity Analysis (Scenario II)	186
TABLE 8.11.	ADSL - Summary of Results, Numerical Methods (Scenario II)	187
TABLE 8.12.	ADSL - Summary of Results, Numerical Methods (Scenario II - Perturbed)	187
TABLE E.1.	Analogue - Monthly Average Traffic/Exchange Line - Minutes	211
TABLE E.2.	Analogue - Active Residential Exchange Lines in BT's In- frastructure (000s)	212
TABLE E.3.	Analogue - Estimated Activation (BT's Residential Exchange Lines)	213
TABLE E.4.	ADSL - Average Headline Tariffs (8 mbit/s)	214
TABLE E.5.	ADSL - Headline Tariffs from Service Providers (8 mbit/s)	215
TABLE E.6.	ADSL - 8Mbit/s, Indicative Headline Promotional Discounts	216
TABLE E.7.	Price Per VP/annum (£) - VBnrt	217
TABLE E.8.	Price per VP/annum (£) - VBrt	218
TABLE E.9.	Price Per VP/annum (£) - CBR	218
TABLE E.10.	ADSL - Ender-User Access Charges (£)	219
TABLE E.11.	ADSL - Customer Access Link Charges (£)	219
TABLE E.12.	Analogue - Conveyance Charges and Useage Factors	219

ACKNOWLEDGMENTS

It has been a journey through the alleys of an intriguing debate on the versatility of contemporary approaches to regulating capacity access in telecommunication networks. A debate that sits at the frontier of the application of finance theory to the regulation of capacity access in telecommunications, and a debate that resonates particularly strongly with the emergence of the next technology frontier in telecommunications, the Next Generation Networks. With this new wave of technology, the challenge of developing a third-party access regime that facilitates innovation and investment, and ultimately facilities-based competition, becomes ever so much more pressing.

I have had the privilege of working with two leading authorities, in the two areas of knowledge that this thesis draws on, Prof. Martin Cave and Prof. Stewart Hodges. Prof. Cave has considerable background in theoretical and applied research in the regulation of telecommunication networks, including access pricing. I am indebted to his knowledge of the broad issues and the freedom that he rendered to explore. I am also indebted to his wit, and the cordial demeanour he engendered - all priceless during the times when the terrain was arduous. Prof. Hodges is a leading authority in finance, with research interests in a wide range of areas including derivative pricing. I am indebted to the scholarly rigour that he brought to the fore. I will remember with great admiration his ability to shift between key themes and minute detail with the most exacting rigour. I must also acknowledge his energy and commitment, a commitment that was forthcoming even when Prof. Hodges had to take on responsibilities at a second institution, towards the final stages of this thesis. I must also mention the valuable interactions I had in the early days of my research with Prof. Sebastian van Strien, Dr. Vicky Henderson, Prof. Paul Stoneman and Prof. Stewart Robinson. These interactions provided useful background in taking stock of the broad landscape at the outset.

During the trying stretches, the mutual encouragement from the many friends and colleagues on both sides of Gibbet Hill Road proved invaluable. Sharing our varied experiences kindled the fire, sustained the momentum and lightened the burden. But in all such endeavours something has to give way. Perhaps more than anybody else our family paid a heavy price. As the demands of the work at hand peaked, there were periods of quiet. I am aware of the ramifications of this but acknowledge with deep gratitude those who showed patience and understanding.

DECLARATION

This thesis is the author's own work. It has not been submitted for a degree at another university.

ABSTRACT

The search for an appropriate approach to pricing capacity access in telecommunication capacity networks has evolved variously in the literature through rate of return regulation, the Efficient Component Pricing Rule, price-cap regulation (RPI-X) and cost-based regulation, based on efficient forward-looking costs - all in search for an approach that would send signals for efficiency to the users of the access infrastructure and thereby facilitate the longer-term efficient development of access networks. In some literature and indeed in practice this search has for the time being settled on FL-LRIC,¹ a cost-based access price, which has been widely advanced as an effective instrument for incentive regulation. An emerging debate in the literature questions the versatility of FL-LRIC from the standpoint of option-theoretic considerations. An issue at the centre of the debate is the versatility of FL-LRIC in responding to the stochastic processes that define downstream value. More specifically, whether, in view of the option-theoretic considerations, FL-LRIC is distortionary and whether such distortions, if any, are sufficiently material to adversely affect competitive outcomes.

This thesis contributes to this debate, which sits at the interface of the theories to access pricing and option pricing, by taking it beyond the qualitative conjectures in literature and makes contributions on the following fronts. First, it develops a framework for valuing the flexibility of adapting to downstream value, and tests the neutrality of FL-LRIC as an approach for pricing capacity access, based on evidence from the analogue and ADSL platforms, using numerical methods. Second, it develops closed-form option-theoretic generalizations of the value of such flexibility, in the two platforms.

The theoretical framework underpinning this thesis is option pricing theory. This theory is used because of its capacity to conceptualize and quantify the value of flexibility. This study uses data from the analogue and ADSL capacity access platforms in the UK. Maximum Likelihood Estimation is used to calibrate the stochastic differential equations describing downstream value and the value of the underlying contingent claims are estimated using risk-neutral valuation measures. From the standpoint of option pricing theory and based on UK evidence we find that: (i) FL-LRIC is distortionary; and (ii) the level of the distortions, imply the existence of a strong incentive for inefficient entry.

¹Forward-looking Long-run Incremental Costs.

ABBREVIATIONS

ACPR	:	Avoided Cost Pricing Rule
ADM	:	Add Drop Multiplexers
ADSL	:	Asymmetric Digital Subscriber Line
ATM	:	Asynchronous Transfer Mode
BFWA	:	Broadband Fixed Wireless Access
BT	:	British Telecommunications Plc.
CAL	:	Customer Access Link
CAT	:	Cumulative Average Temperature
CDD	:	Cooling Degree Days
cdf	:	Cumulative Distribution Function
CLEC	:	Competitive Local Exchange Carrier
DLTU	:	Digital Line Termination Units
DP	:	Distribution Point
D-Side	:	Distribution Side
DSL	:	Digital Subscriber Line
DSLAM	:	Digital Subscriber Line Access Multiplexer
EC	:	European Commission
ECPR	:	Efficient Component Pricing Rule
E-Side	:	End-user Side
EUA	:	End-user Access
ERG	:	European Regulatory Group
FCC	:	Federal Communications Commission
FL-LRIC	:	Forward-looking Long-run Incremental Costs
HDD	:	Heating Degree Days
Hz	:	Hertz
IP	:	Internet Protocol
ISDN	:	Integrated Services Digital Network
ISP	:	Internet Service Provider
Kbit/s	:	Kilobit per Second

LLU	:	Local Loop Unbundling
Mbit/s	:	Megabit per Second
MDF	:	Main Distribution Frame
MEA	:	Modern Equivalent Asset
M-ECPR	:	Modified Efficient Component Pricing Rule
MLE	:	Maximum Likelihood Estimate
NGN	:	Next Generation Network
NTE	:	Network Termination Equipment
Ofcom	:	Office of Communications
PCP	:	Primary Concentration Point
pdf	:	Probability Density Function
PSTN	:	Public Switched Telephone Network
RCU	:	Remote Concentration Unit
RPI-X	:	Retail Price Index minus X-factor
SDE	:	Stochastic Differential Equation
SDH	:	Synchronous Digital Hierarchy
SLTU	:	Subscriber Line Termination Units
TELRIC	:	Total Element Long-run Incremental Costs
TSLRIC	:	Total Service Long-run Incremental Costs
UNE-P	:	Unbundled Network Element Platform
VBR nrt	:	Variable Bit Rate - non real time
VBR rt	:	Variable Bit Rate - real time
VP	:	Virtual Path
Wifi	:	Wireless Fidelity
WiMax	:	Worldwide Inter-operability for Microwave Access

Chapter 1

INTRODUCTION

1.1 Background

The liberalisation of the telecommunications industry saw the emergence of competition between and within different technology platforms. Prior to the 1980s telecommunication companies were operated as vertically integrated monopolies. The 1980s and 90s saw radical policy changes that were aimed at increasing efficiency through privatisation, liberalization and increased competition. In Europe, the UK took the lead in liberalising and privatising its national carrier, and introducing a duopoly in 1984. The duopoly was a precursor to a subsequent more competitive market structure. Other members of the European Community gradually followed suit with policy changes that introduced competition in the 1990s. In the US, the Telecommunications Act of 1996 provided a framework for local and intrastate competition. Across both sides of the Atlantic, mandatory unbundling¹ was introduced as part of the wider initiatives to introduce competition in the parts of the fixed-wire network where replication of infrastructure is not readily feasible.

The rationale for mandatory unbundling is that while competition is desirable in retail and capacity markets, entry is however not readily feasible because of barriers to entry (Hausman and Sidak, 2005). More specifically, the case for mandatory unbundling has been argued for, first, on grounds that by allowing third-parties to rent bottleneck facilities at an initial stage of competition, they are provided with an impetus for subsequent investment in their own facilities, creating in the process, rival networks hence facilities-based competition. In the same vein, Cave and Vogelsang (2003) argue that entrants do not emerge at the outset as fully fledged facilities-based competitors. They argue that com-

¹Mandatory unbundling is an involuntary exchange between an incumbent network operator and third parties (access seekers) where the latter are granted access to the former's capacity network, on terms and conditions which may be determined by a regulator.

petition evolves as third-parties purchase incumbents' network elements and resell retail products. Gradually entrants replace the incumbents' networks elements with their own elements. Pursuing a similar argument, Bauer (2005), and Hazlett and Bazelon (2005) observe that the goals of third-party access products such as unbundled local loops is the introduction of facilities-based competition. Second, the case for mandatory unbundling has been argued for on the grounds that competition between an incumbent and access seekers, and between access seekers, puts downward pressure on retail prices and provides incentives for innovation (Hausman and Sidak, 2005).

The case for mandatory unbundling is however not without opposition. Its opponents have argued that such intervention diminishes an incumbent's incentive to maintain and improve its infrastructure because the incumbent is deprived of the full value of its investment. They have further argued that the short-term benefits from competition may be lower than the long-term harm from reduced innovation. The sharp divide in the arguments on the merits of mandatory unbundling dominates debate in the literature and has given rise to a flurry of empirical research to test the efficacy of unbundling. This body of research has looked at the effect of various policy variables on investment and service penetration. The empirical evidence on the impact of unbundling is not entirely conclusive but suggests that this initiative has not convincingly achieved its intended objectives.

Equally unsettled is the issue about how to price access. The search for an appropriate approach to pricing has evolved variously in the literature through rate of return regulation, the Efficient Component Pricing Rule, price-cap regulation (RPI-X) and cost-based regulation, based on efficient forward-looking costs (FL-LRIC)² – all in search of an approach that would send signals for efficiency to the users of the access infrastructure and thereby facilitate the longer-term efficient development of access networks. In some literature and

²Forward-looking Long-run Incremental Costs.

indeed in practice³ the search for an approach to pricing access has for the time being settled on FL-LRIC, which is advanced in a considerable body of literature as an effective instrument for incentive regulation in telecommunication access networks. Its proponents have argued that access seekers pay a price, and access providers receive a price that corresponds to the costs that the latter imposes on access infrastructure. In this respect, it is argued that FL-LRIC is not only equitable to the access provider but induces entry from access seekers who are either equally or more efficient than the access provider in the intermediate services market (Sappington and Weisman, 1996; Vogelsang, 2003).

A key debate in the literature questions the versatility of FL-LRIC from the standpoint of option-theoretic considerations. Hausman (1999) is one the pioneers of this debate. The subsequent papers by Economides (1999), Hausman and Myers (2002), Alleman (2002), Alleman and Rappoport (2002, 2005, 2006), Vogelsang (2003), Pindyck (2005a, 2005b, 2007) and Cave (2006) add to the debate. An issue at the centre of the debate is the versatility of FL-LRIC in responding to the stochastic processes that define downstream value. Of particular importance is the question about the value of the flexibility to respond to downstream stochastic processes.

³In the EU for example, the European Commission in its Recommendation 98/195/EC of 8th January 1998, on the subject of interconnection in a liberalised telecommunications market, recommended the use of long-run average incremental costs as a basis for setting interconnection charges. The European Parliament and Council subsequently in Directive (2000) 384 on access to, and interconnection of, electronic communication networks and associated facilities, also adopted FL-LRIC as basis for setting interconnection prices. In November 2000 the European Regulatory Group (ERG) endorsed FL-LRIC as basis for setting interconnection prices. According to the ERG most of its members have introduced FL-LRIC. Further, the European Parliament and Council, in Directive 2002/19/EC on access to, and interconnection of electronic networks and associated facilities, stipulated cost-based access prices as a means of regulating capacity access.

1.2 Motivation and Research Questions

While the debate in the literature provides important qualitative conjectures about the potential shortcomings of cost-based price regulation on grounds of the asymmetrical distribution of risk in the access market, it falls short of providing rigorous quantitative option-theoretic arguments, nor any empirical evidence founded on the stochastic dynamics that define downstream value.⁴ Hence the literature still lacks a rigorous analytical framework for analyzing the distortionary effect, if any, of cost-based access prices, from the standpoint of option-theoretic considerations. In particular, still lacking is a framework that maps the stochastic dynamics of value to contingent claim pricing theory. Therefore the basis for addressing the fundamental question about whether the value of the flexibility to respond to downstream stochastic processes is significant relative to the financial equilibrium of access seekers, and whether therefore any such value if unpriced adversely influences market outcomes, is lacking. This research is motivated more immediately by these questions and the challenges they pose. More broadly, this motivation emanates from a keen interest in the emerging application of finance theory to the regulation of network industries.

These questions take the centre stage in the regulation of capacity access in telecommunications for a number of reasons. On one hand, from a theoretical standpoint, a material overstatement of access prices reinforces the dominant position of the incumbent, puts upward pressure on the price of downstream products and distorts the competitive neutrality between alternative technology platforms - a material understatement of access prices encourages inefficient entry, stifles the ability of an incumbent to sustain and improve its infrastructure and distorts the competitive neutrality between competing technology plat-

⁴Pertinent considerations include the properties of the evolution of net average downstream value of an activated exchange line, including its drift and volatility; intensity of exchange line activation, including its drift and volatility; the price of access to the Subscriber Network; the price of market risk; and the price of the risk of default.

forms.

One the other hand, from the standpoint of empirical evidence, first, a number of studies show that the price of access to the local loop is positively correlated to inter-platform competition (see Crandal et al., 2004 and Waverman et al., 2007). The broader significance of this conclusion are findings that show that inter-platform competition has a significantly positive impact on network diffusion (see Distaso et al., 2000; Deni and Gruber, 2005; Aron and Burnstein, 2003). More generally there is widespread consensus in the literature that a mere resale of an incumbent's services does not create value (Cave 2006). Further, other studies show that access seekers did not climb the ladder of investment from unbundling initiatives as would be expected under the stepping stone hypothesis (see Crandall et al., 2004; Hazlett, 2005; Hausman and Sidak, 2005). Second, even if subsidized entry is suggested on grounds that it stimulates competition, it has been argued that the terms of access should mirror a voluntary exchange and reflect the full economic cost of the underlying service. This thesis contributes to this debate.

More specifically, the purpose of this thesis is three-fold. First, to develop a framework for valuing the flexibility of adapting to downstream value, and to test the neutrality of FL-LRIC as an approach for pricing capacity access, based on evidence from the analogue platform, using numerical methods. Second, to develop a framework for valuing the flexibility of adapting to downstream value, and to test the neutrality of FL-LRIC as an approach for pricing capacity access, based on evidence from the ADSL platform, using numerical methods. Third, to develop closed-form option-theoretic generalizations of the value of such flexibility, in the two platforms. The results from the numerical methods provide a check on the results from the closed-form analytical solutions and vice-versa.

The theoretical framework underpinning this study is contingent claim pricing theory. This theory is used because of its capacity to conceptualize and quantify the value of flexibility. Contingent claim pricing theory finds its ori-

gins in Black and Scholes (1973) and the subsequent enhancements in Merton (1973). This study draws on Black (1976) who shows how futures prices can be used to price contingent claims, based on arbitrage arguments. The contribution by Black is particularly important in commodity markets where futures and forward prices are either observable or can be reasonably inferred. Contingent claim pricing theory has been applied using the risk-neutral pricing principle developed by Harrison and Kreps (1979), and Harrison and Pliska (1981, 1983). In applying risk-neutral pricing, the market price of risk is taken to be a handle which links the P -dynamics to the Q -dynamics of downstream value. Maximum Likelihood Estimation is used to calibrate the stochastic differential equations describing downstream value.

1.3 Contributions and Limitations

On original contributions, first, this study provides a rigorous analytical framework, founded on the stochastic dynamics of downstream value, for evaluating the symmetry of FL-LRIC. Second, this study provides empirical evidence on the symmetry or otherwise of FL-LRIC access prices based on evidence from the analogue platform. Third, it provides similar evidence from the ADSL platform. These contributions set this study apart from previous studies and take the debate in the literature beyond the current qualitative conjectures. Fourth, it develops closed-form option-theoretic generalizations of the value of such flexibility, in the two platforms. These analytical solutions generalize the results and provide an option-theoretic approach for pricing access where third parties have the leverage of adapting to downstream stochastic value. In this regard too, this study is significantly different from previous research in the field.

On policy implications, this study informs regulatory policy on the versatility of the contemporary approach used in the telecommunications industry to price access. Turning to directions for regulatory policy, the results point to

three possible remedies. First, binding the access seekers, through space and time to an extent necessary to eliminate one-sided advantages through some form of take-or-pay arrangements, or some variation of this type of contract. Second, migrating to a pricing mechanism that is sensitive to the value of the flexibility to adapt to downstream stochastic processes, through space and time. A third possible policy remedy is co-investment where the incumbent and the access seekers would jointly own access infrastructure and jointly share the upside and downside potential.

While this study contributes to the debate, it is however constrained by the limitations of data in the public domain. The study could be improved in number of ways if the availability of data was not a limitation. First, this study assumes that the distribution of the alternative states of exchange lines is uniform throughout the market studied. However relevant evidence shows that the extent of competition varies from exchange to exchange. More specifically, cable had 95%+ presence in service areas covered by 48 local exchanges; 65-95% presence in the service areas covered by 816 exchanges; 30-65% presence in 293; 5%-30% in 164; and up to 5% in 4,266, at the time of this study. Overall 857 exchanges included in the first two clusters serve 45% of the delivery points in the UK (Ofcom, 2006). Therefore subscribers have a choice of more than one access platform in about one half of the downstream market and the magnitude of the risk of stranded assets varies from exchange to exchange. This suggests that the stochastic state of exchange lines and therefore the value of flexibility will vary also from exchange to exchange. Therefore a more appropriate way to structure the study would be to stratify the various exchanges areas based the stochastic dynamics of the exchange lines. This is has not been done because of the lack of data.

Second, this study assumes a representative portfolio of exchange lines through space and estimates option values from this standpoint. In practice however access seekers have the leverage to work their way through space and cherry pick high-end subscribers with high and stable demand. Therefore the

results from the study should be seen as a conservative estimate of the distortionary effect of FL-LRIC. Third, with respect to the ADSL platform, this research is confined to wholesale access for the 8 mbit/s end-user capacity because of lack of data on other capacities. While this capacity accounts for 43% of the UK market (see Ofcom, 2007), the research could be extended to other capacities if data was not a constraint. Fourth, because of the unavailability of data at more frequent intervals, this study uses quarterly data and monthly data points are estimated by interpolation. While this approach has been used by researchers in the face of data constraints, for example, Henisz and Zelner (2001), it nevertheless adds noise to the data set.

The study points to two directions for future research. First, studying the effect of the distortionary effect of cost-based access prices where third parties purchase only a subset of network elements required to provide end-to-end connectivity. Now while this study is based on the case where a third-party purchases end-to-end connectivity, it is however recognized that an access seeker may opt to purchase only subset of the network elements required to provide end-to-end connectivity, and supplement these with their own elements. Such an alternative results in a risk profile that differs from that studied here and presents an area for further research. The second possible direction for future research is studying the effect of cost-based access prices, if any, on the regulation of Next Generation Networks (NGNs). Now the migration from legacy to NGNs is the most significant technological transformation of telecommunication capacity networks in recent times. NGNs are a single IP-based network with distributed network intelligence and access that allows seamless access to any application in any geographic area. Unlike legacy networks which provide a series of separate products using different technology platforms, NGNs are capable of delivering multiple products (voice, data, video etc.) on a single platform. The migration is in its rudimentary stages and full deployment in European countries is expected by 2020. The migration entails considerable investment and brings with it new dimensions of risk. Substantial segments

of the NGN access infrastructure will however not be readily replicable and incumbents will continue to exercise considerable market power in the access market. Third-party mandatory access to economic bottlenecks will continue to facilitate competition. The primary challenge of third-party access regulation is to create access regimes that facilitate innovation and investment, and ultimately facilities-based competition.

1.4 Organization of Thesis

Chapter 2 reviews the literature on the broader context of the research questions and includes a discussion on ex-poste regulation, the rationale for mandatory unbundling, empirical evidence on the effect of policy variables on facilities-based competition and network penetration, mandatory vertical separation, and theoretical approaches to access pricing. This chapter concludes with a review of the literature on access pricing and the value of flexibility. Chapter 3 is a literature review on the theoretical framework underpinning the analysis in this study i.e. option pricing theory. The research design and methodology are covered in Chapter 4. The coverage in that chapter includes a discussion on the research paradigm, analytical framework, and the structure of the study. In Chapter 5, a framework for valuing the flexibility to adapt to downstream stochastic processes in analogue capacity markets is developed, and evidence from the in the UK, is used to test whether FL-LRIC, as a method for pricing access in telecommunications capacity markets, has a distortionary effect that is significant. In Chapter 6, a framework for valuing the flexibility to adapt to downstream stochastic processes in the ADSL capacity markets is developed, and evidence from the UK is used to test whether FL-LRIC, as a method for pricing access in telecommunications capacity markets, has a distortionary effect that is significant. Closed-form analytical solutions are developed in Chapter 7. These solutions, first, generalize the results and provide an option-theoretic framework for pricing access where third parties have the leverage

of adapting to downstream stochastic value. Second, these solutions provide a basis for checking the results produced by the numerical methods in Chapters 5 and 6. Chapter 8 presents the results and includes a discussion. The conclusion is in Chapter 9.

Chapter 2

MANDATORY UNBUNDLING AND ACCESS PRICING

2.1 Introduction

The immediate literature that this thesis builds on is that on capacity access pricing in telecommunication access markets and option pricing theory. The broader relevant literature is that on vertical integration, market power and anti-competitive behaviour; regulatory remedies including mandatory unbundling of telecommunications capacity networks, and vertical separation; and access pricing. This chapter reviews the immediate and broader body of literature. On vertical integration, the literature emphasizes weighing its pro-competitive benefits and anti-competitive effects. While mandatory unbundling is advocated where there exist enduring bottlenecks, empirical evidence on its effect on investments and network penetration is not entirely conclusive but point to two directions. First, that inter-modal competition has positive and significant impact on service penetration. Second, the price of access to the local loop is positively and significantly correlated to facilities-based deployment.

The search for an approach to pricing access in unbundled networks has for the time being settled on cost-based access prices based on efficient forward-looking costs, FL-LRIC,¹ in a considerable body of literature, and in fact in practice. An emerging debate questions the versatility of this approach to pricing on account of option-theoretic arguments. These arguments however see a transition in the characterization of the anomaly attributed to cost-based prices. This transition has three key strands of arguments. First, that sunk costs truncate cash flows and result in an asymmetrical distribution of risk. Second, regulatory prescriptions give rise to investment inflexibility and therefore

¹Equivalent terms in some jurisdictions include Total Element Long-run Incremental Costs (TELRIC) and Total Service Long-run Incremental Costs (TSLRIC).

have an opportunity cost from a real options perspective. Third, the asymmetrical flexibility to adapt to downstream stochastic processes at the level of an exchange line has value.

This study builds more immediately on the third tier of the debate in the literature by carrying out an empirical investigation to test the symmetry of FL-LRIC. More specifically, the purpose of this study is three-fold. First, to develop a framework for valuing the flexibility of adapting to downstream value, and to test the neutrality of FL-LRIC as an approach for pricing capacity access using numerical methods, from the standpoint of option pricing theory, in the analogue platform. Second, to develop a framework for valuing the flexibility of adapting to downstream value, and to test the neutrality of FL-LRIC as an approach for pricing capacity access using numerical methods, from the standpoint of option pricing theory, in the ADSL platform. Third, to develop closed-form option-theoretic generalizations of the value of such flexibility, in the two platforms.

The questions that this thesis addresses are important from a theoretical standpoint, for a number of reasons. A material overstatement of access prices reinforces the dominant position of the incumbent, puts upward pressure on the price of downstream products and distorts the competitive neutrality between alternative technology platforms - a material understatement of access prices encourages inefficient entry, stifles the ability of an incumbent to sustain and improve its infrastructure and distorts the competitive neutrality between competing technology platforms. Section 2.2 reviews the literature on ex-post regulation, Section 2.3 discusses the rationale for mandatory unbundling and also reviews empirical results on its effect on facilities-based competition and network penetration, Section 2.4 discusses ex-ante regulation and mandatory vertical separation, Section 2.5 discusses theories to pricing access and Section 2.6 discusses access pricing and the value of flexibility.

2.2 Vertical Integration and its Competitive Effects

The question about the pro and anti-competitive effects of vertical integration continues to be at the centre of the debate in antitrust and regulatory literature. In the last four decades the debate has seen gradual shifts starting with the rather restrictive views on vertical integration in the 1970s. The foreclosure doctrine, which dominated the thinking then, conjectured that the owner of a bottleneck facility has the incentive to leverage its market power from the bottleneck segment to the adjacent competitive or potentially competitive segments. Foreclosure is discussed in the literature as taking either of two forms: raising rivals' costs or reducing rivals' revenues – the former encompasses ceasing to supply downstream rivals or doing so at anti-competitive prices i.e. input foreclosure. Reducing rivals' revenues entails barring affiliated downstream firms from obtaining supplies from independent upstream firms. One of the pioneering applications of the foreclosure doctrine was in *Terminal Railroads Association v. USA (1912)*. The doctrine subsequently found application in landmark cases including *Brown Shoe Co. v. USA (1962)*.

In what is commonly referred to as the Chicago School critique, researchers for example, Posner (1976), challenged the foundations of the foreclosure doctrine arguing that, where there exists a vertically integrated firm with market power in the bottleneck segment, there exists only one market for the final good and hence only one monopoly profit to be earned. A vertically integrated firm can earn the monopoly profit by exerting its market power in the bottleneck segment. Such a firm does not therefore have an incentive to distort downstream competition (see Riordan and Salop, 1994; Rubinfeld and Singer, 2001; and Church, 2004). Imperfect competition in the downstream market therefore only adversely affects the profits of the monopoly supplier. On the basis of this argument, vertical integration can only be motivated by the need to enhance efficiency. This view dominated much of anti-trust arguments in the 1980s – for example, in the US, the 1982 and 1984 non-horizontal merger guidelines were

largely founded on this premise.

The Chicago School critique was subsequently found to be wanting because the assumptions underlying the critique – that the monopoly service provider was protected by barriers to entry and was unregulated, that there was perfect competition in the downstream market and that inputs were used in fixed proportions – were overly restrictive. In the absence of these restrictive assumptions the single monopoly profit theory does not hold – instead it is argued that vertical integration can be motivated by monopoly power, economic efficiencies or both (see Church, 2004). This forms a key tenet of the Post-Chicago critique. The Post-Chicago critique, while not entirely discounting the Chicago School critique, emphasizes both competitive and anti-competitive effects of vertical integration (Riordan and Salop, 1994 and Cooper et al., 2005). The potential benefits from vertical integration are seen to include superior coordination in the production chain, elimination of double-marginalization, reduced cost of capital from diversification and a stronger commitment to sunk capital. The potential anti-competitive harm is seen to include the extremes of market power, for example, foreclosure to access inputs or customers (Hazlett, 2002). The Post-Chicago critique provides key tenets of antitrust and regulatory practice today where the emphasis is on weighing the pro-competitive benefits of vertical integration against its anti-competitive effects. See, for example, the EU guidelines on non-horizontal merger guidelines of 2000 and the US guidelines on non-horizontal merger guidelines of 1997. In telecommunications, the key ex-post remedy for foreclosure is resolution under competition law. The key ex-ante regulatory remedies include structural remedies such as mandatory vertical separation, behavioural remedies such as mandatory unbundling with or without regulated access prices; and access quality control (Farrel and Weiser, 2003).

In the EU, the rulings in the landmark cases *Bronner (Oscar) GmbH & Co v. Mediaprint GmbH & Co (1998)* and *Sea Containers Ltd v. Stena Sealink Ports (1995)* provide much of the binding legal precedence with respect to the frame-

work of third-party access to a bottleneck facility (essential facility)² under EU competition law. The overriding principle established in the rulings is that an entity controlling a bottleneck facility should provide access to such a facility on reasonable terms, if it is feasible to do so. These and subsequent rulings culminated in a specific criteria for assessing allegations of abuses of dominant positions with regard to third-party access to bottleneck facilities. The key considerations in establishing a case of abuse of dominance are whether: (i) access is essential for competition in the relevant market; (ii) there is sufficient capacity for access to be provided; (iii) the facility owner is failing to satisfy demand, blocking the emergence of a new product or service, or impeding competition in an existing or potential market; (iv) the potential customer is prepared to pay a reasonable price; and (v) there is no objective reason to refuse access. In the US, the essential facilities doctrine provides the basis in common law to provide access. In telecommunications, the doctrine found application in *MCI Communications Corp. v. American Telephone & Telegraph Co. (1983)*. In this case it was ruled that to prove an abuse of a dominant position the aggrieved party needs to show: (i) control of the essential facility by a monopolist; (ii) a competitor's inability to practically or reasonably duplicate the essential facility; (iii) the denial of the use of the facility to a competitor; and (iv) the feasibility of providing the facility.

While the essential facilities doctrine presents a front in common law to address abuses of market power that have occurred, ex-ante regulation presents an administrative front to address potential abuses of market power. Ex-ante regulation in telecommunications is in the main affected through either mandatory unbundling or vertical separation, with or without price controls. The case for ex-post regulation has been argued for on grounds of the risk regulatory failure of ex-ante regulation. It has been argued that ex-ante regulation depends on the ability of the regulator to reasonably accurately synthesize the

²A bottleneck facility is an input required by a competitor to compete in a downstream market (or a neighbouring market), where it is not economically or physically feasible to duplicate such facility – see Whish (2003).

direction of technological developments and their corresponding commercial implications. This is a difficult task given the fluidity of technological changes in telecommunications.

The case for ex-post regulation has been further argued for on grounds of information asymmetry between operators is lower than that between regulators and operators. This coupled with the threat of law and the surveillance imposed on the access provider by other operators in the access market have been argued to be adequate to put pressure on a dominant firm to behave competitively. On the other hand, some researchers have argued for ex-ante regulation on grounds of its relative advantages in the speed of execution and technical expertise. The next section discusses ex-ante regulation and mandatory unbundling.

2.3 Ex-ante Regulation and Mandatory Unbundling

2.3.1 Unbundling: Rationale

Mandatory unbundling of fixed-wire telecommunication networks is discussed in a considerable body of literature as a regulatory intervention for promoting competition in retail and capacity markets. The rationale for this intervention is that while competition is desirable in these markets, entry is however not readily feasible because of barriers to entry which include scale economies, sunk costs and first-mover advantages (Hausman and Sidak, 2005). The case for mandatory unbundling has been argued for, first, on grounds that it facilitates platform competition through the “ladder of investment” hypothesis. The premise of this argument is that by allowing entrants to rent bottleneck facilities at an initial stage of competition, they are provided with an impetus for subsequent investment in their own facilities, creating in the process, rival networks hence facilities-based competition. This argument, also referred to as the "stepping stone" hypothesis, is perhaps best articulated by Cave (2006). In the same vein, Cave and Vogelsang (2003) argue that entrants do not emerge as at the outset as fully fledged facilities-based competitors. They argue that compe-

tition evolves as entrant's purchase an incumbent's network elements and resell its retail products. Gradually the entrants replace the incumbent's networks elements with their own elements. Second, the case for mandatory unbundling has been argued for on the grounds that competition between an incumbent and access seekers, and between access seekers, puts downward pressure on retail prices and provides incentives for innovation (Hausman and Sidak, 2005).

The case for mandatory unbundling is however not without opposition. Opponents of mandatory unbundling have argued that such intervention diminishes an incumbent's incentive to maintain and improve its infrastructure because the incumbent is deprived of the full value of its investment. They have further argued that the short-term benefits from competition may be lower than the long-term harm from reduced innovation. The sharp divide in the arguments on the merits of mandatory unbundling dominates debate in the literature and has given rise to a flurry of empirical research to test the efficacy of unbundling. This body of research has looked at the effect of various policy variables on investment and service penetration. The empirical evidence on the impact of alternative regulatory prescriptions is however, in the main, non-conclusive. We consider a cross-section of key studies in this area.

2.3.2 Unbundling and Service Penetration

Murillo and Gabel (2003) investigate how policy variables including unbundling, ownership and competition impact broadband deployment. The other independent variables considered include retail price, number of registered domain name servers and demographic factors including income, education, penetration of narrowband and access to personal computers, among others. The study uses cross-sectional data from 135 countries. The study finds that income, retail price, ownership and competition are important drivers of broadband diffusion. The study however finds that unbundling is not a significant driver of broadband diffusion.

Kim et al. (2003) investigate the effect of policy variables, retail price, price

of dial-up service, income, preparedness, competition and population density on broadband diffusion. The study uses cross-sectional data from 30 OECD countries. This study finds that the most consistent factors that explain broadband diffusion are the drivers of cost and the preparedness of a country. Policy variables including unbundling, competition and government funding do not exhibit a significant influence on broadband diffusion. While unbundling had a positive effect on adoption, this was not significant. Further, while not significant, the more intense is competition, the less intense is broadband adoption.

Wallsten (2005) investigates the effect of policy and demographic variables on broadband penetration (ADSL, cable and total deployment) based on US-evidence. The study uses state-level cross-sectional data covering the period 1999 to 2004. On policy variables, the study investigates whether unbundling through UNE-P and through resale impact broadband penetration. In addition to the policy variables, the study investigates the effect of public rights of way, municipal restrictions, availability of loans and tax incentives on service penetration. The study finds that the concentration of UNE-P leased lines is negatively and significantly correlated to ADSL rollout. This finding supports the view that unbundling deters investment by the incumbent. The concentration of UNE-P lines on total broadband penetration and cable penetration is however not significant. Further, the study finds that the concentration of lines used by access seekers under the resale programmes is positively and significantly correlated to total and ADSL broadband penetration. The concentration of resale lines is however only weakly positively correlated to cable penetration.

Wallsten (2006) investigates whether policy options including full unbundling, bitstream access, sub-loop unbundling, collocation (remote and virtual comingling), regulation of line rental and collocation charges, and demographic factors including telephone line per capita and GDP per capita impact penetration and delivery speeds available to subscribers. The study is based on cross-sectional panel data covering the period 1999-2003 from 30 OECD countries.

This study is differentiated from previous studies, first, because it distinguishes the various forms of unbundling (full unbundling, bitstream access, sub-loop unbundling). Second, because it considers the effect of policy and demographic factors not just on penetration but also delivery speeds. The study finds that population density has a positive and significant impact on penetration and connection speeds. The study also finds that the effect of full unbundling on deployment is ambiguous with the relevant coefficients ranging from positive and significant to negative and significant depending on model specifications. The study finds that sub-loop unbundling has a negative and significant impact on deployment. Bitstream access is found to have an insignificant effect on penetration. Co-mingling is found to generally have a positive effect on penetration and virtual collocation the opposite effect. Regulatory approval of collocation charges is found to have a negative effect on deployment.

Aron and Burnstein (2003) investigate the influence of availability, competition and demographic influences on broadband deployment.³ The study is based on US evidence and uses state-level cross-sectional data from 46 states. The demographic variables considered include education, tele-density, and length of access lines, among others. The study finds that inter-modal competition positively and significantly impact broadband adoption. In fact they find that the impact of competition almost entirely eliminates the impact of availability. Deni and Gruber (2005) investigate the effect of the concentration of intra-platform competition, concentration of inter-platform competition, proportion of incumbent lines, tele-density and central office upgrade on broadband deployment. The study is based on US evidence and uses state level cross-sectional panel data covering the period 1999 to 2004. They find that there is a positive and significant correlation between inter-platform competition and broadband deployment. They also find that intra-platform competition has a positive and significant impact on broadband deployment but this effect dissipates rapidly.

³Availability is measured by the relative coverage of either ADSL or cable services and competition is measured by the proportion of the subscriber base served by both ADSL and cable.

While the effect of the broad policy variables is necessarily of interest, of relevance too is the effect of the narrower prescription embodied in the price of access. Eisner and Lehman (2001), Crandall et al. (2004), Ford and Spiwak (2004) and Waverman et al. (2007) look at the impact of access price on diffusion. Now Eisner and Lehman study how access prices interact with three forms of competitive entry – resale, UNE-based and facility-based entry. The study is based on state-level cross-sectional data from 48 states in the US. The variables considered include UNE prices, population density, resale discounts and employment, among others. They find that facilities-based entry is negatively correlated to the level of UNE prices. They however find that the effect of UNE prices on resale and unbundling is ambiguous. The study by Crandall et al. (2004) also investigates the impact of price on diffusion. The study uses state-level cross-sectional panel data, from two sources (incumbents and FCC) and covers the period 2000 and 2001. Using the two data sets, the study finds a positive and significant correlation between the log of the ratio of facility-based lines and UNE lines. Further the study finds that the growth of facilities-based lines was higher in the states where the cost of UNEs was higher relative to the cost of facilities-based lines.

Waverman et al. (2007) study the impact of LLU prices on broadband adoption using cross-sectional panel data covering the period 2000 to 2006 from 12 OECD countries. More specifically, the study looks at how the price of LLU; the level of competitor lines offered over PSTN, incumbent DSL lines and non-DSL lines; availability of bitstream access; and market concentration of LLU, impact broadband adoption. The study finds that LLU prices are positively and significantly correlated to the level of subscribers using alternative platforms – in summary, a 10% reduction in LLU prices gives rise to a 18% decrease in the number of subscribers using alternative platforms. The authors conclude that low LLU prices deter facilities-based competition. Distaso et al. (2006) study the impact of inter and intra-platform competition on broadband diffusion using evidence from 14 European countries. They find that the correlation between

inter-platform competition and broadband diffusion is positive and significant. They however find that the correlation between intra-platform competition and broadband diffusion is not significant.

Ford and Spiwak (2004) investigate how broadband adoption is impacted by local loop access costs and prices, per capita income, availability (percentage of zip codes in a state that have at least one provider of broadband services), competition (defined as the proportion of zip codes in a state with at least four service providers), relative proportion of rural population and the number of large cities in a state. The study is based on US evidence and uses state-level cross-sectional panel data covering the period 2002 and 2003. The study finds that both availability and competitiveness primarily depend on the relative proportion of rural population, time and the price of the unbundled loop. It is shown that the price of access to the local loop is negatively and significantly correlated to both availability and competitiveness.

Hazlett (2005) reviews the US access market in the period 1999 to 2004. He observes that during this period UNE-P lines emerged to dominate the portfolios of access seekers. During this period UNE-P lines grew by over 300% and facilities-based lines grew by just 20%. In fact the number of non-cable facility-based lines decreased from 4.1 million to 3.2 million during this period. Hazlett finds that the correlation between the growth of UNE-P lines and non-cable facilities-based competition is -0.99 and concludes that UNE-P lines crowd out facilities-based competition. Of interest too is that during the period 1999 to 2004, while the lines operated by access seekers reflected a continuous period-to-period increase, the level of their non-cable facilities-based lines showed a decline bringing to doubt the “stepping stone” hypothesis. Hazlett also finds that investments by incumbents and access seekers are negatively correlated to the growth of shared lines (coefficient of correlation for the period 2000 to 2003 is -0.94). Hazlett also finds that the rate of deployment of DSL increased after the repeal of the mandatory line sharing requirements in the US.

Crandall et al.(2004) present data showing that UNE lines in access seekers’

portfolios increased from 24% in 1999 to 55% in 2002. This indicates that access seekers did not migrate to facilities-based competition as would be envisaged under the “ladder of investment” hypothesis. Hausman and Sidak (2005) follow the evolution of lines operated by 17 access seekers in 2000 and find that 25% of these increased the proportion of facility-based lines in their portfolio – 50% of the firms maintained about the same proportion of facilities-based lines. Some firms went bankrupt and others decreased their share of facilities-based competition.

The above studies show mixed results. Three possible reasons are adduced to explain this. First, the dynamics of supply and demand in a complex industry, as is the case with broadband, could be more complicated than what econometric models are able to capture. Second, the varying conditions of supply and demand between countries and between states may possibly render oversimplistic the assumption that a single model is suitable in all circumstances. Third, the length of time covered by the time series data is in some cases very short, for example, refer to Ford and Spiwak (2004) and Crandall et al. (2004). This limits the traction required to decipher cause and effect linkages. Lastly, the variety of models presented by the various researchers illustrate that even at a conceptual level there is no agreement on the constituent drivers of supply and demand. Now case study research, for example, Aizu (2002), has been used to grapple with the complexity of the subject matter. This has provided some persuasive analysis of the dynamics of broadband deployment in Korea, Hong Kong, Singapore and Japan.

Despite the mixed results, two fairly persuasive results emerge from the studies. First, that inter-modal competition has positive and significant impact on broadband diffusion (see Aron and Burnstein, 2003 and Deni and Grubber, 2005). Second, the price of access to the local loop is positively and significantly correlated to facilities-based deployment (see evidence from Crandall et al., 2004 and Waverman et al., 2007).⁴ This read together with the data pre-

⁴The effect of unbundling on diffusion is ambiguous – refer to Murillo and Gabel (2003),

sented by Crandall et al. (2004), Hazlett (2005) and Hausman and Sidak (2005) about the less than satisfactory migration from service-based to facilities-based competition suggests that the influence of price, in particular its symmetry or otherwise, presents an interesting area for further enquiry. Could it be that an artificial suppression of the price of the local loop explains the suppression of facilities-based competition? This question gives a broad context to the subject of this research – an enquiry into the symmetry or otherwise of FL-LRIC.

2.4 Ex-ante Regulation and Vertical Separation

Mandatory vertical separation is a regulatory intervention for promoting competition in retail and capacity markets. It has been argued that mandatory unbundling cannot ensure equality of access because it gives an incumbent conflicting incentives. While equality of access is a prerequisite for achieving the objectives of mandatory access, the access provider benefits from discriminatory practices. For example, an integrated access provider benefits from delays in providing access services, degradation of access quality or price discrimination. Mandatory vertical separation is suggested in the literature as a remedy where there exists a persistent bottleneck in a network and where traditional regulatory prescriptions, for example mandatory unbundling, cannot provide remedies for abuses of market power (see Crandal and Sidak, 2002).

Mandatory vertical separation overcomes the risk of leveraging market power by putting the retail arm of the incumbent on the same footing as its downstream competitors. Therefore the incentive to provide preferential treatment to downstream competitors is, in theory, largely eliminated. Proponents of vertical separation argue that it provides a level playing field by eliminating incentives to discriminate in the downstream market through for example, increasing rivals' costs. In effect vertical separation aligns the interests of the access providers with those of downstream competitors. The case for vertical

Kim et al. (2003), Wallsten (2005) and Wallsten (2006).

separation has also been argued for on the grounds that the provision of access is necessarily complex and providing such access by an integrated firm will necessarily be litigious. Vertical separation considerably reduces the need for expensive litigation. Further, vertical separation eliminates incentives to cross-subsidize between upstream and downstream markets. Equally importantly, vertical separation eliminates the risk of free riding by entrants and reduces the burden of regulation (see de Bijl, 2005).

Vertical separation takes three main forms. First, accounting separation, under which the downstream and upstream arms of an integrated entity maintain independent accounting records. Accounting separation however is merely a booking-keeping undertaking and its impact on corporate behaviour is necessarily minimal. Second, functional separation, where the downstream and upstream arms of an integrated firm are separated into two independent divisions or legal entities with separate management and assets, but with the two arms having the same ownership. Functional separation merely relocates the upstream arm of a business to a point outside the immediate influence of the downstream business or vice versa. Ultimately, however the downstream arm remains subject to the same overall corporate authority as the retail arm and therefore both arms are necessarily tied to the same overall corporate objectives. The effectiveness of functional separation must therefore be necessarily weak.

The third form of vertical separation is structural separation, under which the downstream and upstream arms of an integrated firm are separated into two independent legal entities with separate ownership. Structural separation sends strong signals because it completely separates the downstream and upstream functions – it is however not without costs. Such separation entails forgone advantages of coordination and forgone economies of scope. Structural separation is not only a necessarily costly and disruptive process but also one that increases the cost of capital because of the loss of the advantages of coordination and because the forgone economies of scope increase the underlying business

risk. Further, structural separation removes the single point of accountability that subscribers would otherwise look up to. In addition, vertical separation eliminates the advantages that a vertically integrated firm would have to bundle services (see Crandal and Sidak, 2002). Ultimately, one therefore needs to weigh the benefits and costs of separation and only pursue such separation if its benefits outweigh its costs. Empirical evidence on the overall effect of the various forms of vertical separation is still lacking in the literature and opens an interesting area for research.

2.5 Ex-ante Regulation and Pricing Access

2.5.1 Rate-of-Return Regulation

Rate-of-return regulation also known as cost-of-service regulation was widely applied across most network industries prior to the mid-1980s. Under this approach, the price of access is set ex-ante at a level that compensates the service provider for both operating and capital costs. The recovery of capital costs is based on the rate base (stock of capital assets required to deliver the service) and the applicable rate of return. This rate is equivalent to that would be earned by investments with a similar risk exposure. The rate base will usually be based on historical costs with common costs allocated on the basis of either output, attributable costs or revenue. Proponents of rate of return regulation have argued that this approach bases prices on cost causality and is therefore equitable. They argue further that rate-of-return regulation provides incentives for improvements in efficiency and productivity given that prices during a regulatory lag are fixed thereby providing an impetus to reduce costs and maximize profits. Unlike the price-cap approach to regulation, rate of return regulation has a handle on the totality of the financial equation defining value for the service provider and therefore provides a more comprehensive means for influencing the behaviour of a service provider.

Rate of return regulation however lost much of its appeal from the mid-1980s because of concerns about its inefficiency. Rate-of-return regulation is seen to be inefficient because of the Averch-Johnson effect (see Averch and Johnson, 1962). The reasoning here is that rate-of-return regulation gives a service provider the incentive to unjustifiably expand the rate base and thereby increase the regulated price. Kahn (1988) discusses the Averch-Johnson effect using evidence from the electricity industry. Kahn observes that suppliers: resisted the adoption of cheaper and more efficient technology, avoided cost-effective measures like leasing when this was warranted, failed to coordinate to purchase electricity from other suppliers even when this was cost-effective, avoided peak-load pricing and adopted unnecessarily high standards of reliability.

Rate-of-return regulation has other perverse incentives. Efficiency and productivity gains are translated into lower prices in the next regulatory lag thereby discouraging any such improvements in the first place. Rate of return regulation is also inefficient at the operating level – the assurance to recover operating costs discourages improvements in efficiency and productivity. Further, rate-of-return regulation discourages investment in new technology where such technology reduces the rate base of the service provider. Lastly, rate-of-return regulation has the further drawback of the regulatory burden associated with rate setting. Mathios and Rogers (1989) provide evidence that shows that telephone tariffs were higher in the states that used rate-of-return regulation relative to those that used price-cap regulation.

Economic theory suggests that the allocation of common costs on the basis of output, attributable costs or revenue does not maximize welfare. To this extent the rate-of-return regulation fails the welfare test. Ramsey prices provide a formulation that ensures that sunk costs of a multi-product firm are recovered while at the same time simultaneously ensuring that consumer surplus is maximized. This is achieved by marking up the prices of the various products above marginal cost in inverse proportion to the respective price elasticities. Despite

its widespread recognition in economic literature, Ramsey prices have however not found practical application because of the difficulties associated with determining price and cross-price elasticities. A further limitation of Ramsey prices lies in its implied inequities. In effect, in certain circumstances, products which are social necessities but which have low price elasticities absorb a larger proportion of common and joint costs relative to those products with higher price elasticities but which may not be social necessities. The subject of the allocation of joint and common costs with respect to pricing in a multi-product firm continues to be at the centre of controversy between economic literature and public policy. While economic literature has advocated the maximization of consumer surplus, public policy has leaned towards equity, as measured by cost causation, or approximations of such causation.

2.5.2 The Efficient Component Pricing Rule

The Efficient Component Pricing Rule (ECPR), as an approach to pricing access, has been widely discussed in the literature and in fact at some point found its way into practice in some jurisdictions, for example, New Zealand. ECPR was first proposed by Willig (1979). Its advocates theorize that, because the access provider provides upstream inputs used by its downstream rivals, the price of a unit of access should equal the incremental cost of providing one unit of access plus the opportunity cost of providing access. The theory however holds where: the access provider's price is based on the marginal pricing rule; the access provider's and access seeker's services are perfect substitutes; there are constant returns to scale for both the access provider and access seeker; the access seeker has no market power; and the access provider's marginal cost of production can be accurately observed. Doane et al. (1996) propose M-ECPR, a refinement of ECPR. M-ECPR has identical conceptual underpinnings to ECPR only that under the former, the access price is based on the lowest price of the downstream good, where such lower price is available from an alternative access provider.

Its advocates argue that ECPR ensures efficient entry and is equitable to an access provider because it prices access at incremental cost and takes account of the opportunity cost for providing access; is non-discriminatory because the provision of access does not encroach onto the access provider's net income; ensures that access is only sought by firms that are equally or more efficient than the access provider;⁵ and the incentive of access provider to invest in infrastructure is not distorted because the access provider's pre-entry profits is preserved (see Sidak and Baumol, 1994 and Baumol et al., 1997).

ECPR's drawback is that it bases the access price on the access provider's pre-entry prices which are unlikely to be efficient. These pre-entry prices will mostly likely correspond to historical costs and harbour the influence of monopoly inefficiencies. The historical costs will have imbedded inefficiencies and will not reflect the most efficient use of current and anticipated technology. ECPR in effect therefore protects pre-entry technology and productivity and does not provide incentives to adapt the most efficient technology. Neither does ECPR provide incentives for the most efficient use of such technology.

Economides and White (1995 and 1998) provide proof of the general inefficiency of ECPR. The essence of this proof is that ECPR perpetuates high prices which result in the loss of consumer surplus and social welfare relative to prices that reflect social economic costs. Economides (1997) argues that the shortcomings of ECPR and M-ECPR lies in the fact that these approaches to pricing are based on private and not social opportunity costs. Economides observes the private opportunity costs of a monopoly will necessarily reflect higher prices associated with imbedded inefficiencies and monopoly profits and argues that such opportunity costs do not reflect social opportunity costs, which should equate to the efficient use of resources by society. He further argues that an access provider should not be compensated for its private opportunity costs but rather the social opportunity costs because higher prices implied by

⁵For if an access seeker was less efficient than the access provider then entry would be unprofitable.

ECPR result in consumer welfare loss. In the US, the Federal Commission of Communication in assessing the merits of ECPR in its First Report on the implementation of the 1996 Act, concluded that:

ECPR is an improper method for setting prices of interconnection and unbundled network elements because the existing retail prices that would be used to compute incremental opportunity cost under ECPR are not cost-based. The ECPR, however, will serve to discourage competition because it relies on the prevailing retail price in setting the price which new entrants pay the incumbent for inputs. While ECPR establishes conditions for efficient entry given existing retail prices, as its advocates contend, the ECPR provides no mechanism that will force retail prices to their competitive levels.

A further weakness of ECPR is that a decrease in the cost of transforming the upstream products does not translate in a corresponding decrease in the price of the downstream products. In fact a decrease in the cost of transformation does not necessarily result in a decrease of the access price. Lastly, an access price that is bloated with historical inefficiencies and monopoly profits will be above the efficient cost of access. The higher the differential between the ECPR-determined access price and efficient costs, the higher will be the incentives to duplicate the access network, albeit even if inefficiently.

The retail-minus approach to pricing is built on the ECPR. Retail-minus provides a safeguard against margin squeezes (see King and Maddock, 2003). A margin squeeze arises when a vertically integrated supplier leverages its market power in the upstream market to remove or constrain competition in the downstream market – in this case by squeezing the margins of downstream competitors. A margin squeeze is said to occur when the aggregate of the access price and the efficient costs of transforming the upstream product exceed the price of the downstream product. In essence a retail-minus price is the retail price less the costs that would be avoided by a service provider if it ceased

to provide the retail service. Avoided costs therefore include all those costs associated with the retail activity. Kaserman and Mayo (1997) and Beard et al. (1998) provide a finer interpretation of the avoided costs under retail-minus pricing. They interpret avoided costs to include three components: (i) incremental cost at the retail stage incurred by an efficient supplier, (ii) additional costs incurred at the retail stage which are attributable to inefficiencies, and (iii) economic profit earned by the access provider for the retail activity. Kaserman and Mayo (1997) and Beard et al. (1998) term this definition of the retail-minus price, the Avoided Cost Pricing Rule (ACPR). ACPR has the thrust of ECPR – while the broad principles are the same under the two approaches, the former assumes an efficient supplier while the latter does not. Overall while retail-minus pricing has the advantage of simplicity and a lighter regulatory burden, the most significant drawback of retail-minus pricing is that it assumes the prevailing retail prices are competitive.

2.5.3 Price-cap Regulation

The dissatisfaction with the weak signals for efficiency under rate of return regulation ushered in the era of incentive regulation. As implied by its name, incentive regulation is intended to provide incentives for efficiency and productivity improvements to service providers with significant market power. One of the pioneering banners of incentive regulation was price-cap regulation, which provides a ceiling for the regulated prices. The most common approach to price-cap regulation has been the RPI-X model which allows regulated prices to increase by the rate of inflation less the X-factor which captures efficiency and productivity gains. In theory this should be calibrated such that the access providers and consumers share the gains from improvements in efficiency and productivity. Littlechild (1983) is credited for giving prominence to price-cap regulation in network industries. Following Littlechild's work, RPI-X regulation was initially applied in telecommunications industry in UK. Subsequently price-cap regulation was used in the water, electricity, natural gas and transportation

sectors in the UK. RPI-X regulation then found its way to other jurisdictions outside the UK, for example, access regulation in telecommunications in the US. In putting forward a case for RPI-X regulation, Littlechild, argued that this form of price regulation is superior to alternative forms of price control from the standpoint of considerations including: protection against monopoly, provision of incentives for efficiency and innovation, reduction on the burden of regulation and promotion of competition. In supporting price-cap regulation, Acton and Vogelsang (1989) observe:

Thus, rather than creating regulation based on the premise of an omniscient regulator being able to set optimal prices based on full knowledge of costs and demand, a more realistic regulatory goal is to design incentive mechanisms for the regulated firm that will lead it to maximize society's objectives (whether these are efficiency, distributive, or other objectives) while pursuing its self-interest. Price caps are viewed as an attractive means for implementing such incentive schemes, although we must acknowledge that maximizing a social objective function potentially places even greater informational burdens on the regulator.

RPI-X however has a number of drawbacks. First, the measurement of efficiency and productivity, in markets where the dynamics of supply are characterized by complexity, is problematic. This is the case in telecommunications capacity access where technology, traffic and other factors impacting on efficiency and productivity are fluid. Second, price cap regulation decouples prices from costs. Now the financial equation defining equilibrium returns of an access provider, the primary input for decision making, is a composite of prices and costs. By having a handle only on prices and not costs, price-cap regulation is rendered a weak tool for modulating behaviour in the access market. Further, because it does not have a handle on all the drivers of value, price-cap regulation does not provide the tools to ensure that the returns accruing to the access seeker correspond to what would be attained in a competitive market.

Accordingly therefore, price-cap regulation necessarily leads to an exposure to windfalls for either the access providers or access seekers and is thereby likely to provide distorted signals for efficiency. MacDonald, Norsworthy and Fu (1994) suggest that the practical problems associated with implementing price-cap regulation explain its slow adoption in telecommunication access markets. Evidence on the effect of incentive regulation has been contradictory. Shin and Yang (1993) find that incentive regulation gives rise to higher costs. Tardiff and Taylor (1993), and Schmalensee and Rohlfs (1992) find that incentive regulation gives rise to higher productivity. Greenstein et al. (1995) find that incentive regulation results in higher levels of investments in infrastructure. Tardiff and Taylor (1993) however find that there is no statistical evidence to support the claim that incentive regulation gives rise to higher levels of investments in infrastructure. Brown et al. (1989) discuss the UK experience with respect to quality deterioration. Brennan (1989) discusses the adverse effects of price-cap regulation on quality of service.

2.5.4 Cost-based Regulation

In some literature and indeed in practice the search for an approach to pricing access has for the time being settled on cost-based prices based on efficient long-run incremental costs (see Hausman and Sidak (2005)). First, we consider the conceptual basis of FL-LRIC, a cost-based approach. As implied by its title, FL-LRIC encompasses three tenets: forward-looking - long-run - incremental costs. Forward-looking denotes costs incurred to efficiently provide a future service. The long run is a time frame period over which all costs, including those related to network capacity, are variable. Incremental costs are those costs that can be attributed directly to a service and are therefore avoidable if the service in question is not provided. In the context of FL-LRIC an increment refers to a total service or a whole volume of interconnection or access service that the access provider produces or is likely to produce. This characterization distinguishes incremental costs from marginal costs and its essence is that is

captures the full breath of costs incurred to provide access.

FL-LRIC is also advanced in a considerable body of literature as an effective instrument for incentive regulation in telecommunication access networks. Proponents of FL-LRIC, have argued that its tenets including its forward-looking and long-run approach to estimating costs, use of optimized scorched node network configuration, use of MEAs to project capital costs and use of DCF to establish a financial equilibrium based on the weighted average cost of capital, all taken together provide appropriate incentives for productive and dynamic efficiency. It is argued that access seekers pay a price, and access providers receive a price that corresponds to the costs that the latter imposes on access infrastructure. Consequently, access seekers bear a cost that is equivalent to the social cost of supply. In this respect, it is argued that FL-LRIC, is not only equitable to the access provider but induces entry from access seekers who are either equally or more efficient than the access provider in the intermediate services market (Sappington and Weisman, 1996; Vogelsang, 2003). Economides (1999) observes:

Appropriate pricing of unbundled network elements, transport, and access termination is crucially important for promoting effective competition. The extent to and the speed with which competition will develop depend critically on having prices for unbundled network elements and services that are close to the economic costs as possible. The more prices exceed efficient costs, the less entry there will be. The less entry there is, the less likely it will be that effective competition will develop in the local exchange markets, and, if effective competition does develop, it will happen more slowly. There is only one cost measure that fulfils. . . .that cost measure is the long-run forward looking economic cost, or Total Element Long-run Incremental Cost.

In addition, it has been argued that access priced at cost provides the correct signals for efficient consumption by neither artificially encouraging nor discour-

aging consumption. An access price below cost of service encourages consumption above a level that is socially optimal. Conversely, an access price above cost artificially restricts consumption and brings with it the risk of duplicating access infrastructure. Further, its proponents argue that FL-LRIC ensures competitive neutrality between competing technologies because the access price reflects the cost that access seekers exert on the respective technological platforms. Therefore, it is argued, that an access platform, would not in any way be put at a competitive advantage or disadvantage relative to platforms using alternative technologies, if access was priced using FL-LRIC.

It can be argued that the conceptual basis of FL-LRIC as an approach to pricing access is open to question. Now under FL-LRIC, it is assumed that the users of the access infrastructure take a predictable and static path through a space of possibilities during a regulatory lag. The assumed path is some trajectory, between the extremes in the possibility space, measured by an average value. This premise is however questionable. Access seekers are able to adapt favourably to the stochastic processes generating value in the access infrastructure. This raises the question of the relative value of the flexibility that gives a third party the leverage to adapt to the stochastic processes that generate value.

2.6 Access Pricing and Value of Flexibility

2.6.1 Value of Flexibility

A key debate in the literature questions the versatility of FL-LRIC from the standpoint of option-theoretic considerations. Hausman (1999) is one of the pioneers of the debate. The subsequent papers by Economides (1999), Hausman and Myers (2002), Alleman (2002), Alleman and Rappoport (2002, 2005 and 2006), Vogelsang (2003), Pindyck (2005a, 2005b and 2007) and Cave (2006) add to the debate. An issue at the centre of the debate is the versatility of FL-LRIC in responding to the stochastic processes that define downstream value.

Of particular importance is the question about the value of the flexibility to respond to downstream stochastic processes.

The arguments in the literature see a transition in the characterization of the anomaly attributed to cost-based prices from the standpoint of option pricing theory. This transition has three strands of arguments. First, that sunk costs truncate cash flows and result in an asymmetrical distribution of risk. Second, regulatory prescriptions give rise to investment inflexibility and therefore have an opportunity cost from a real options perspective. Third, the asymmetrical flexibility to adapt to downstream stochastic processes at the level of an exchange line has value. These three strands of arguments are however not concisely compartmentalized and in fact at times overlap in the literature.

In the first strand of arguments, Hausman (1999) frames the issue as one where the fundamental premise of TSLRIC (US equivalent term for FL-LRIC) is fundamentally flawed because it assumes a perfect contestability standard under which costless entry and exit exist. Hausman argues that costless entry and exit presume no sunk costs and this presumption deviates from the reality in the access market where the bulk of the investments are sunk. Therefore, going by this argument, TSLRIC does not permit a mark-up over cost to allow for the risk associated with sunk investments. Hausman observes that while TSLRIC makes an allowance for the cost of investment and variable costs, it makes no allowance for sunk costs. Hausman concludes that because TSLRIC ignores the sunk nature of investment, it confers free options to third parties. Hausman and Myers (2002) take a similar strait and argue that the non-existence of barriers to entry truncates the upside because of either entry or the threat of entry. At the same time there is no downside protection because of the existence of sunk costs. This gives rise to an asymmetrical distribution of cash flows and hence lower than expected returns. Therefore, according to this argument, an upward adjustment of the regulated rates is required to correct this anomaly and ensure competitive returns.

The premise of the arguments by Hausman (1999), and Hausman and Myers

(2002) are however vulnerable. Now cost, in the context of TSLRIC/FL-LRIC, includes a mark-up for a competitive return – in addition to being forward-looking, equivalent to the costs of a least cost provider, being incremental, having a long-run orientation, and being exclusive of monopoly profits and cross-subsidies (see Economides, 1999). The relevant instructive provision, competitive returns, implies a return on capital that is equivalent to what assets with a similar risk exposure would earn. Such risk must however necessarily include the risk attributable to sunk investments.

Alleman (2002), Alleman and Rappoport (2002, 2005 and 2006) and Pindyck (2005), adapt the second strand of arguments. These authors take the premise that regulatory prescriptions give rise to investment inflexibility and therefore have an opportunity cost from a real options perspective. As real options theory suggests, the flexibility, for example, to delay, abandon or start/stop a project has value.⁶ The delay option is considered particularly relevant in telecommunications because once a service provider sinks capital, they in effect exercise their options. The opportunity cost associated with such exercise is however not incorporated in cost-based prices. The primary context of these studies is that the traditional approach to pricing access is static and assumes that management has no flexibility to change direction as the states of nature are revealed through the passage of time. For example, Pindyck (2005) observes that in the presence of uncertainty, there is an opportunity cost of investing rather than waiting for the arrival of new information about the prospects of an investment. Pindyck adds that when the investment option is exercised there is an associated loss of value which should be included as part of the investment cost. Accordingly the traditional approach to pricing does not capture the value of managerial flexibility. Pindyck suggests that a real options approach to pricing would capture the asymmetrical distribution of risk in the access infrastructure. The core of the second strand of arguments are perhaps best encapsulated in Alleman and Rappoport (2002) and run as follows:

⁶For a broad exposition of real options theory, see Trigeorgis (1996).

If the company faces a common carrier obligation to provide broadband services and to maintain payphones, the requirement to provide broadband services eliminates the company's option to delay. Similarly, the inability to exit the payphone business eliminates the firm's ability to exercise its abandonment option. regulation can restrict the flexibility of the firm through the imposition of price constraints and by imposing costs associated with either delay, abandonment, or shutdown/restart options. the real options analysis provides a means of capturing the flexibility of management to address uncertainties as they are resolved. the flexibility that management has includes options to defer, abandon, shutdown/restart, expand, contract, and switch use. the deferral option is the one that is generally illustrated and is treated as analogous to a call option. the question is: what is the investment worth with and without management flexibility. in these situations (broadband and payphones), the incumbent carriers are precluded from exercising the option to delay in the first case, and the option to abandon in the second case. A related option is the ability to shutdown and restart operations. the lack of options has not been considered in the various cost models that have been utilized by the regulatory community for a variety of policy purposes.

The arguments by Alleman (2002), Alleman and Rappoport (2002, 2005, 2006) and Pindyck (2005), have their basis in the implications of the obligation to serve. The thrust of these arguments is that if a service provider is constrained by regulation and if as a consequence there result limitations on, for example, when and where to enter a market or when and where to exit, then there are opportunity costs from a real options perspective, which should be added to the cost of investment and be borne by the users of the access infrastructure. The fundamental question must therefore be whether regulation imposes such constraints. The case in telecommunications suggests that the implications of regulation on investment timing, which we refer to here as Tier

I flexibility, may not be as severe as suggested in the literature. If one considers the case of, for example, broadband roll-out, the facts are that a capacity access provider has the leverage to determine the technology and the pace of roll-out. Regulatory encumbrances on the timing of investments are in the main non-existent. In fact Alleman and Rappoport (2002) observe that at the time of their study there was no legislation in the US restricting the flexibility of service providers with respect to network roll-out. In the UK, the timing and location of broadband roll-out has proceeded in accordance with the discretion of the access providers. Now if the exercise of an investment option by a service provider is sub-optimal for reasons other than restrictions imposed by regulation, then it is inappropriate that the cost of this should be borne by either competing access seekers or retail subscribers. Absent regulatory constraints, a service provider has an obligation to ensure that the timing of their investments is optimal.⁷

Turning to the analogue access market, the effect of regulatory intervention by way of universal service obligations – the one area where regulation impacts investment timing flexibility – are unlikely to be consequential because these obligations affect peripheral catchment areas. One would therefore expect that network roll-out, in the main, proceeds in a manner consistent with the discretion of an incumbent. In conclusion, while acknowledging the merits of the second strand of arguments, it is nevertheless noted that the implications of these may not be as severe as suggested in the literature because of the said mitigating factors. More generally some researchers, for example, Economides (1999) suggest that in oligopolistic interactions, first mover advantages can be crucial and therefore the value of waiting may be negative.

The third strand of arguments suggest that cost-based access prices, independent of investment timing flexibility, are distortionary because they do not respond to the value of the flexibility to adapt to the stochastic processes that

⁷It is instructive to note that Tier I flexibility and the value of this is independent of the obligation to provide mandatory access. The opportunity cost related to Tier I is necessarily added to the direct costs to establish the aggregate cost of investment.

define downstream value at the operational level.⁸ This cluster of arguments alludes to asymmetrical operational flexibility that arises as a consequence of the obligation to provide capacity access to third parties who have the flexibility to align entry and exit decisions to the stochastic dynamics at the level of an exchange line. To give an example of arguments that subscribe to this cluster, Pindyck (2007) observes that local loop unbundling is flexible, allowing an entrant to rent facilities in small increments for short durations with no long-term commitments. Pindyck argues that the *operational flexibility* conferred to entrants is of great value and is costly for incumbents to supply. Pindyck concludes that the traditional approach to pricing access is not efficient and discourages incumbents, and in the long run undermines the objective of promoting facilities-based competition. Vogelsang (2003) notes that access seekers do not have a long term commitment to the access infrastructure and are thus able to protect themselves from downside risks, leaving an incumbent exposed to the risk of stranded assets if demand vanishes. Cave (2006) suggests that FL-LRIC is not adequately responsive to the distribution of risk between an incumbent and an access seeker. He notes that FL-LRIC ignores the fact that access seekers have the option of continuing to buy access products unlike incumbents - therefore the appropriate access price should include the access price and the value of the option to buy. Cave concludes that regulatory strategy should be designed to generate sustainable infrastructure-based competition where feasible.

The common thread in the third strand of arguments is that access seekers are not bound by long-term commitments and can walk in and out at the level of exchange lines. In essence, an incumbent provides access at the option of its rivals who utilize the infrastructure at their discretion. This gives the access seeker the advantage of exercising the option when, for example, it can attract business at the level of an exchange line. Equally the access seeker has the leverage not to exercise the option when, for example, an exchange line is de-

⁸This class of flexibility is referred to here as Tier II flexibility.

activated. This protects an access seeker from the downside of operational risk but confers to it the upside potential. On the other hand an incumbent, having sunk capital, is exposed to the full spectrum of risk. All this gives a significant competitive advantage to an access seeker. The asymmetrical distribution of risk effectively confers an advantage to the access seeker analogous to a free financial option at the level of delivery points. Such asymmetrical distribution of risk has value and therefore a price.⁹

2.6.2 Situating the Research Questions

This thesis builds more immediately on the third strand of arguments in the literature. It is recognized that the upside and downside at the level of the delivery points will migrate within the network and the ability to align entry and exit to such migration has value because it confers exposure to the upside and not the downside. The essence of the third strand of arguments is that an access seeker is conferred a bundle of rights through space and time, at the level of exchange lines. Now while the access provider provides inputs used by the access seeker to compete with the former in the downstream market, and while the latter pays an access price based on the cost of capital, the access seeker is not fully exposed to the risk captured by the cost of capital. An access seeker is able to favourably align its market entry and exit to the stochastic processes that generate value at the level of an exchange line (operational level) and in essence, for each time interval obtain the substantive equivalent of a call option. For each such interval, the right conferred to an access seeker is analogous to a contingent claim defined on the process generating value.

While the debate in the literature generally provides important qualitative conjectures about the potential shortcomings of cost-based price regulation on grounds of the asymmetrical distribution of risk in the access market, it falls

⁹It is instructive to note that Tier II flexibility and the related concerns only arise when third-party access is mandated. The related opportunity cost is a relevant cost in pricing a unit of access at the level of the exchange line.

short of providing rigorous quantitative option-theoretic arguments, nor any empirical evidence founded on the stochastic dynamics that define downstream value.¹⁰ Hence the literature still lacks a rigorous analytical framework for analyzing the symmetry of cost-based access prices, from the standpoint of option-theoretic considerations. In particular a framework that maps the stochastic dynamics of value to contingent claim pricing theory. Therefore the basis for addressing the fundamental question about whether the value of the flexibility to respond to downstream stochastic processes is significant relative to the financial equilibrium of access seekers, and whether therefore any such value if unpriced adversely influences market outcomes, is still lacking. This research is motivated more immediately by these questions and the challenges that they pose. More broadly, this motivation emanates from a keen interest in the emerging application of finance theory to the regulation of network industries.

These questions take the centre stage in the regulation of capacity access in telecommunications for two reasons. First, on one hand, while the case for less than competitive terms of access has been put forward on grounds that this stimulates competition, on the other hand, a number of empirical studies have shown that the price of access to the local loop is positively correlated to facilities-based deployment (see evidence in Crandall et al. (2004) and Waverman et al., 2007). Somewhat corroborating evidence, based on the trend of migration from service-based to facilities-based competition, is found in, for example, Crandall et al. (2004), Hazlett (2005) and Hausman and Sidak (2005). Further, Bauer (2005), Cave (2006) and Waverman (2006) observe that the policy of "easy access" in the US created resellers who did not climb the ladder of investment and build their own infrastructure. The US experience shows how regulation impinged social welfare by furthering intra-modal competition at the

¹⁰Pertinent considerations include the properties of the evolution of net average downstream value of an activated exchange line, including its drift and volatility; intensity of exchange line activation, including its drift and volatility; the price of access to the Subscriber Network; the price of market risk; and the price of the risk of default.

expense of inter-modal competition. Cave (2006) observes that the policy of "easy access" impedes facilities-based competition and cites evidence from the US where a product UNE-Platform (UNE-P) was introduced in 1999. This product allowed competing operators to lease an incumbent's entire local service at discounts between 50-60% of retail prices. UNE-P resulted in a market with a high presence of leased lines and a stagnation of facilities-based competition. It is estimated that UNE-P accounted for nearly half of the total lines that were in service at the time the product was discontinued. The lesson learned was that competitive investments are unlikely to materialize if access products are made available on disproportionately favourable terms. Hausman and Sidak (1999) capture this argument aptly, as follows:

.....they (TSLRIC prices) also discourage the use of and investment in competitors' own facilities. The availability of those UNEs at inefficiently low prices not only attracts firms that could have deployed their own facilities, but also induces firms that could not have efficiently entered or expanded in the marketplace to do so. The subsidized prices shield inefficient entrants from the true economic prices that they would otherwise be forced to face.....thus, CLECs can tenably argue that access to unbundled elements is necessary for all sunk-cost elements because competitive supply of those elements will not exist. The competitive supply will not arise because the Commission has set an uneconomically low price for the element that does not recognize the sunk-cost nature of the required investments.

Second, on the matter of the less than competitive terms of access, shifting the burden of subsidized entry to an incumbent can be argued to be a violation of the property rights of the incumbent. The confiscatory drawbacks of regulation are perhaps best articulated by Sidak and Spulber (1997). They argued that an incumbent takes pioneering initiatives and invests in long-lived and non-salvageable assets with the expectation to penetrate the market and

make a return on its investments. Subsequently, in the interests of competition and the benefits that this confers to consumers, regulators mandate third-party entry into the market. Sidak and Spulber argue that regulatory rules should however not be confiscatory nor destructive to the property rights of the incumbent service provider. Sidak and Spulber further argue that any regulatory intervention that changes the legitimate expectations of a utility should, on grounds of equity, confer a just compensation which mirrors the outcome of a voluntary exchange, and should therefore yield the full economic cost of willingly parting with the relevant assets.

2.7 This Thesis

While the case for mandatory vertical separation continues to be debated, and while the issue about mandating third-party capacity access and the broader rationale for this is not entirely settled, even more unsettled is the issue about how to price access. The search for an appropriate approach to pricing has evolved variously in the literature through rate of return regulation, the Efficient Component Pricing Rule, price-cap regulation (RPI-X) and cost-based regulation, based on efficient forward-looking costs (FL-LRIC) – all in search of an approach that would send signals for efficiency to the users of the access infrastructure and thereby maximize consumer welfare. The stakes in this search have been high. On one hand, a material overstatement of access prices reinforces the dominant position of the incumbent, puts upward pressure on the price of downstream products and distorts the competitive neutrality between alternative technology platforms. On the other hand a material understatement of access prices encourages inefficient entry, stifles the ability of an incumbent to sustain and improve its infrastructure and distorts the competitive neutrality between alternative technology platforms. The overarching objective of regulation should however be to foster outcomes that mimic those in competitive markets.

This thesis builds on the debate in the literature by investigating the distortionary effect of FL-LRIC, in the main, from the standpoint of Tier II flexibility. More specifically, the purpose of this study is three-fold. First, to develop a framework for valuing the flexibility of adapting to downstream value, and to test the neutrality of FL-LRIC as an approach for pricing capacity access, based on evidence from the analogue platforms, using numerical methods. Second, to develop a framework for valuing the flexibility of adapting to downstream value, and to test the neutrality of FL-LRIC as an approach for pricing capacity access, based on evidence from the ADSL platform, using numerical methods. Third, to develop closed-form option-theoretic generalizations of the value of such flexibility, in the two platforms. Maximum Likelihood Estimation is used to calibrate the stochastic differential equations describing downstream value and the value of the underlying contingent claims are estimated using risk-neutral valuation measures. The results from the numerical methods provide a check on the results from the closed-form analytical solutions and vice-versa. The theoretical framework underpinning this study is option pricing theory. The motivation for using this theory arises from its capacity to conceptualize and quantify the value of flexibility. This study distinguishes between the analogue and ADSL platforms because of differences in the dynamics that create downstream value between the two platforms.

On original contributions, first, this study provides a rigorous analytical framework, founded on the stochastic dynamics of downstream value, for evaluating the symmetry of FL-LRIC. Second, this study provides empirical evidence on the symmetry or otherwise of FL-LRIC access prices based on evidence from the analogue platform. Third, it provides similar evidence from the ADSL platform. These contributions set this study apart from previous studies and take the debate in the literature beyond the current qualitative conjectures. The analytical solutions generalize the results and provide an option-theoretic approach for pricing access where third parties have the leverage of adapting to downstream stochastic value. In this regard too, this study is significantly

different from previous research in the field.

Chapter 3

OPTION PRICING THEORY

3.1 Introduction

The theoretical framework underpinning the analysis in Chapters 5, 6 and 7 is option pricing theory. The theory is implemented in this thesis using martingale pricing principles.¹ Now contingent claim pricing theory has been discussed in the literature under two main paradigms – initially in absolute terms using rational expectations arguments and subsequently in relative terms using arbitrage arguments. The earlier paradigm has been shown to be inefficient because it fails to recognize opportunities to benefit from riskless profits from hedging. The subsequent paradigm dominates economic and finance literature and provides the foundation for the contemporary approaches to contingent claim valuation in the two disciplines. The essence of this theory is that it should not be possible to guarantee a riskless profit through hedging.

The widely acclaimed Black and Scholes (1973) paper provides the foundation for the prevailing approaches to pricing contingent claims using arbitrage arguments. Black and Scholes derive a closed-form solution, based on a dynamic portfolio replication strategy, for pricing European options in continuous time. Merton (1973) extends the Black and Scholes model by relaxing its restrictive assumptions about dividends and interest rates. Black (1976) derives a closed-form solution, for pricing options on futures contracts, building on the earlier work by Black and Scholes, and Merton. The paper by Black (1976) has been instrumental in providing a framework for pricing commodity derivatives in circumstances where futures and forward prices are either observable or where these can be reasonably inferred. Cox et al. (1979) provide a framework for

¹The terms martingale pricing and risk-neutral valuation are used inter-changeably in this thesis.

valuing contingent claims where the value of the underlying asset is defined by a discrete-time binomial process.

Harrison and Kreps (1979) and Harrison and Pliska (1981 and 1983) provide the foundations for contingent claim valuation under martingale pricing principles. Martingale pricing draws more immediately on the risk-neutral pricing insights by Cox et al. (1979). The key argument in martingale pricing is the link between the absence of arbitrage and the existence of equivalent martingale measures. Martingale pricing provides a versatile tool for pricing derivatives and has been successfully applied to price contingent claims where the underlying is one of a wide variety of variables, including, for example, financial assets or indices. In this chapter, a cross-section of studies that apply martingale pricing, in particular, in circumstances where futures and forward prices provide an alternative to the spot price as a basis for pricing derivatives, are discussed. This review covers electricity and weather derivatives. Because of the non-storable character of electricity, electricity derivatives provide instructive insights relevant to contingent claim analysis in telecommunication access capacity markets. Weather derivatives too provide important insights because the underlying is not a tradable commodity. While the range of applications of martingale pricing reviewed in this chapter is not necessarily complete because of the limitations of space, this review nevertheless brings out the salient elements of martingale pricing deemed necessary in considering contingent claim analysis in telecommunication capacity markets. The rest of this chapter is laid out as follows – Section 3.2 sets out the broad principles of option pricing theory. Section 3.3 provides an overview of martingale pricing; Section 3.4 provides an overview of how martingale pricing has been applied to electricity and weather derivatives. Section 3.5 provides an overview of key literature on the pricing of defaultable claims.

3.2 Hedging by Dynamic Replication

While much of the earlier research on option pricing theory is credited to Sprenkle (1961), Ayres (1963), Boness (1964), Samuelson (1965), Baumol et al. (1966) and Chen (1970), the contemporary approach to option pricing in continuous time is credited to Black and Scholes (1973) who derived a closed-form solution, for pricing European options, based on a dynamic portfolio replication strategy. The solution is based on a hedged position consisting of a long position in a stock and a short position in an option. Their derivation assume that short-term interest rates are known and are constant; the price of the underlying asset follows a process of the form $dS(t)/S(t) = \mu dt + \sigma dW(t)$; the underlying asset pays no dividends; there are no transaction costs; the option is European; borrowing any fraction of the price of the underlying security is permissible; and there are no penalties for short-selling. Under these conditions the value of the option does not depend on the price of the stock but on time and known constants. Merton (1973) extends the results of Black and Scholes (1973) by relaxing its restrictive assumptions about dividends and interest rates. He develops closed-form solutions for pricing options where the underlying asset pays dividends and where interest rates are non-constant but deterministic.

The framework in the papers by Black and Scholes (1973) and Merton (1973) have been extended to provide closed form-analytical solutions for pricing contingent claims where the underlying is a commodity spot, futures or a forward price. To illustrate, Black (1976) derives a closed-form analytical solution to price an option on a futures contract where the price of the underlying is defined by a Geometric Brownian Motion, as follows

$$C(F(t) : t, T) = e^{-r(T-t)}[F(t, T)N(d_1) - KN(d_2)] \quad (3.1)$$

here

$$d_1 = \frac{\ln\left(\frac{F(t,T)}{K}\right) + \frac{1}{2}\sigma^2(T-t)}{\sigma\sqrt{T-t}}$$

and

$$d_2 = d_1 - \sigma\sqrt{T-t}$$

for $T > t$. Now $F(t, T)$ is the price of a futures contract written at time t for delivery at time T . Eqn.3.1 assumes the arbitrage arguments – that it is possible to build a riskless portfolio by combining a short position in one call option and a long position n futures contracts. Now from the spot-forward relationship we have

$$F(t, T) = S(t)e^{(r-y)(T-t)} \quad (3.2)$$

Using the relationships in Eqn. 3.1 and Eqn. 3.2 we have

$$C(F(t) : t, T) = S(t)e^{-y(T-t)}N(d_1) - Ke^{-r(T-t)}N(d_2) \quad (3.3)$$

Eqn. 3.4 shows the closed-form solution for the price of a European call option on a commodity spot, $C(S(t); t, T)$, written at time t and maturing at time T , and where the underlying spot price process is described by a Geometric Brownian Motion.

$$C(S(t) : t, T) = S(t)e^{-y(T-t)}N(d_1) - Ke^{-r(T-t)}N(d_2) \quad (3.4)$$

where

$$d_1 = \frac{\ln\left(\frac{S(t)e^{-y(T-t)}}{Ke^{-r(T-t)}}\right) + \frac{1}{2}\sigma^2(T-t)}{\sigma\sqrt{T-t}}$$

and

$$d_2 = d_1 - \sigma\sqrt{T - t}$$

Here $S(t)$ is the price of the underlying asset at time t , K is the exercise price, σ is the volatility of the price of the underlying asset and y is the convenience yield. Now Eqn. 3.3 and Eqn. 3.4 are identical. The use of futures and forward prices has been instrumental in providing a framework for pricing derivatives where the spot price or spot index are either not readily observable or are not traded. We extensively draw on this fact in the analysis in Chapters 5-7.

Cox et al.(1979) provide a framework for valuing contingent claims where the value of the underlying asset is defined by a discrete-time binomial process. The premise underpinning the Cox et al. model is that a portfolio consisting of shares of the underlying asset and risk-free borrowing can be constructed to replicate the value of an option on the underlying asset. Since the option and the replicating portfolio have the same returns, these two assets must necessarily sell for the same price to avoid arbitrage. In the one period case they show that the price of an option, written at time t and maturing at time T , is

$$\begin{aligned} C(t, T) &= \frac{C_u - C_d}{u - d} + \frac{uC_d - dC_u}{(u - d)r} \\ &= \left[\left(\frac{r - d}{u - d} \right) C_u + \left(\frac{u - r}{u - d} \right) C_d \right] / r \end{aligned} \quad (3.5)$$

here C_u is the value of the call in the optimistic scenario and C_d its value in the pessimistic scenario at time T . Now u is one plus the rate of return on the risky asset in an optimistic scenario and d is one plus the rate of return on the risky asset in the pessimistic scenario. Here $q = \frac{r-d}{u-d}$; $1 - q = \frac{u-r}{u-d}$; and r is a wealth relative² on a risk-free asset. The price of a call option can therefore be simplified as follows

²One plus the risk-free rate of interest.

$$C(t, T) = [qC_u + (1 - q)C_d]/r \quad (3.6)$$

It is instructive to note that the objective probability measure, p , does not appear in the pricing formula. What matters are the relative values of C , S , u , d and r . Now since $1 \geq q \geq 0$, this can be interpreted as a probability measure - in this case a risk-neutral probability measure. The price of an option is therefore an expectation under risk-neutral probabilities. In the next section we show how risk-neutral pricing in discrete time can be extended to a continuous time framework.

3.3 Martingale Pricing

Harrison and Kreps (1979) and Harrison and Pliska (1981 and 1983) provide the foundations for contingent claim valuation under martingale pricing. Martingale pricing draws on the broad framework of the earlier papers by Black and Scholes (1973) and more immediately on the Cox et al. (1979) paper. Martingale pricing extends the notion of risk-neutral pricing to continuous time. The key argument in martingale pricing is the link between the absence of arbitrage and the existence of martingale measures. A martingale measure, Q , is a probability measure on the space (Ω, F) such that Q and the objective measure P are equivalent measures such that $Q(X) = 0$ if and only if $P(X) = 0$, for every $X \in F$; the Radon-Nikodym derivative dQ/dP is square integrable with respect to P ; and the relative discounted prices $S(t)/B(t)$ under Q -expectations are martingales.³ Harrison and Pliska (1983) provide proofs of the tenets of arbitrage pricing theory and show that a market is free of arbitrage if there exists a martingale measure; a market is complete if the martingale measure is unique; and the price of a contingent claim in an arbitrage free market is equivalent to

³Here $S(t)$ represents the spot price of a risky asset and $B(t)$ a money market account where $B(0) = 1$.

the discounted payoffs of the claim under risk-neutral probabilities, discounted at the risk-free rate.

In essence, martingale pricing rests on the premise that in an efficient market, a portfolio cannot have a zero value at time t , and a positive value at T (where $T > t$) with a corresponding non-zero probability of negative value at T . In other words the absence of arbitrage implies that the expected future value of an asset at T under risk-neutral probabilities discounted at the risk-free rate is equal to its value at t . If we consider an interval $[t, T]$, the price of a contingent claim, $C(t, T)$, under the martingale pricing principle is given by

$$\frac{C(t, T)}{B(t)} = [qC_u + (1 - q)C_d]/B(T) \quad (3.7)$$

where C_u , is the value of the contingent claim in the favourable state, C_d is the corresponding value of the claim in the unfavourable state at time T and q is a risk-neutral probability. This very much corresponds to the risk-neutral arguments by Cox et al. (1979). $B(t)$ represents the numeraire at time t which is customarily taken to be a money market account. The expression in Eqn. 3.7 above can be simplified to

$$\frac{C(t, T)}{B(t)} = E^Q \left[\frac{C(T)}{B(T)} \right] \quad (3.8)$$

where E^Q denotes an expectation under an equivalent martingale measure. More formally, the price of a contingent claim relative to the money market account at t and the pay-off of the claim relative to the money market account at T are martingales – or more simply, the relative prices are martingales.

Now if we have a portfolio of a stock and a risk-less asset, a necessary and sufficient condition for the non-existence of arbitrage is that an equivalent martingale measure exists such that the price of the stock relative to the risk-free asset is a martingale. If we consider the interval $[t, T]$, this implies

$$\frac{C(S(t) : t, T)}{B(t)} = E^Q \left[\frac{S(T) - K}{B(T)} \right] \quad (3.9)$$

Now turning to martingale valuation in continuous time, the evolution of the money market account and the price of the risky asset can be represented as follows

$$dB(t) = rB(t)dt \quad (3.10)$$

and

$$dS(t) = S(t)(udt + \sigma dW(t)) \quad (3.11)$$

where $B(0) = 1$. We let $D(t)$ represent the price of the risky asset relative to the money market account i.e. $D(t) = S(t)/B(t)$. Using, Ito's formula we have

$$dD(t) = D(t)[(u - r)dt + \sigma dW(t)] \quad (3.12)$$

If we have that P and Q are equivalent measures, from a martingale pricing standpoint, the immediate matter is to define the Q -dynamics of Eqn. 3.12. For this we use the Randon-Nikodym derivative $L(t) = dQ/dP | F(t)$. By Girsanov's Theorem, the Randon-Nikodym derivative for the change of measure of a P -Brownian motion is

$$L(t) = \exp \left[- \int_0^t \lambda(s)dW(s) - \frac{1}{2} \int_0^t (\lambda(s))^2 ds \right] \quad (3.13)$$

Using Girsanov's Theorem, the relationship between the P and Q -Weiner processes are as follows

$$dW(t) = d\widetilde{W}(t) - \lambda(t)dt \quad (3.14)$$

where $\widetilde{W}(t)$ is a Q -Weiner process. Using Eqn. 3.14 above the Q -dynamics of the $D(t)$ -process is represented as follows

$$dD(t) = D(t)[(u - r - \sigma\lambda(t))dt + \sigma d\widetilde{W}(t)] \quad (3.15)$$

Now that $D(t)$ evolves as a martingale, the following must necessarily hold.

$$u - r - \sigma\lambda(t) = 0 \quad (3.16)$$

Therefore

$$\lambda(t) = \frac{u - r}{\sigma} \quad (3.17)$$

If Eqn. 3.17 holds, then the Q -dynamics of the $S(t)$ -process can be represented as follows

$$dS(t) = S(t)[r dt + \sigma d\widetilde{W}(t)] \quad (3.18)$$

Now $\lambda(t)$ in Eqn. 3.17 is commonly referred to as the market price of risk and is central to the valuation of contingent claims. The market price of risk can be interpreted as the price of a unit of volatility. It is a handle which transforms a process defined by a P -measure to a process defined by a Q -measure. In the case of $dS(t)/S(t) = u dt + \sigma dW(t)$, this results in a relocation of the path of $S(t)$ to that that would prevail in a risk-free world. We make extensive use of this argument in the analysis in Chapters 5-7.

3.4 Applied Martingale Pricing

The application of risk-neutral pricing where the underlying is either a non-financial or non-tradable asset is considered in this section. In doing this electricity and weather derivatives are discussed. In discussing electricity derivatives, the papers by Vehvilainen (2001), Schwartz and Lucia (2002), Benth et al. (2003), Audet et al. (2004), Burger et al. (2004) and Cartea and Figueroa (2005) are considered. The papers by Alaton et al. (2002), Brody et al. (2002)

and Benth and Benth (2005 and 2007) are considered in reviewing weather derivatives. The the key arguments in these papers are considered and how these can inform derivative pricing in telecommunication capacity access markets. While the range of applications of martingale pricing reviewed in this chapter is not necessarily complete because of the limitations of space, this review nevertheless brings out the salient elements of martingale pricing deemed to be relevant in considering contingent claim analysis in telecommunication capacity markets.

Electricity derivatives emerged following the liberalization of electricity markets. Now the liberalization led to competitive wholesale markets - and competition in the wholesale markets in turn led to greater volatility of the spot price and a growth in derivative products both in the physical and financial markets. A number of features distinguish electricity derivatives from other commodity derivatives. First, electricity is largely a non-storable commodity. Therefore unlike most other commodities, the spot price at time T is not a function of the spot price at $t < T$. The traditional arbitrage arguments which define the relationship between a spot and a forward price in commodity markets, i.e. $F(t, T) = S(t)e^{(r-y)(T-t)}$, does not apply.⁴ Second, electricity markets are primarily local because of limitations in transporting electricity over long distances. Because of the limitations of carrying electricity through space and time, the spot price is largely dependent on the local conditions of supply and demand.

In electricity markets the spot price gravitates towards the cost of production hence the mean-reverting processes that describe the spot. This is coupled with seasonal variations and spikes in spot prices which reflect temporary mismatches between supply and demand. The SDEs describing the spot price process developed by, for example, Schwartz and Lucia (2002)⁵ cap-

⁴Here $F(t, T)$ is the price of a forward with a time T delivery, for a contract written at time t , $S(t)$ is the spot price, r is the return on a risk-free asset and y is the convenience yield.

⁵And some earlier unpublished papers.

ture the mean-reversion and seasonality. Clewlow et al.(2001) and Cartea and Figueroa (2005), for example, supplement the mean-reversion and seasonality with jumps. A number of studies on pricing electricity derivatives are motivated by Harrison and Kreps (1979). Under this broad framework, the pricing of electricity contingent claims has been based on one of two processes. First, the spot price process as in the case in, for example, the studies by Lucia and Schwartz (2002) and Cartea and Figueroa (2005). Second, the forward price process as in the case in, for example, the studies by Clewlow and Strickland (1999) and Audet et al. (2004). The studies that use the forward price process have their theoretical foundations in Black (1976) and capitalize on the existence of data on forward curves. Where data of forward curves is lacking, spot price dynamics have been used to derive forward curves, as for example in Lucia and Schwartz (2002). Here the forward price is taken to be equivalent to the price of the spot under risk-neutral measures, that is, $F(t, T) = E^Q[S(T) | F_t]$. Here the Q -dynamics are derived from the P -dynamics by change of measure.⁶ In essence, the spot price is translated into a forward price through the intermediary of the market price of risk. Other studies that use this approach include Vehvilainen (2001), Cartea and Figueroa (2005), Burger et al. (2004) and Benth et al. (2003). Benth et al. (2003) derive forward prices as a function of the spot price. The theoretical forward price thus derived is the basis for the valuation of contingent claims.

The derivation of electricity derivatives based on both spot and forward prices is considered, starting with the former approach. Now Lucia and Schwartz (2002) price electricity derivatives based on the spot price process. We discuss here their key arguments using their one factor model. Now they define the process describing the evolution of the spot price, $P(t)$, as follows

$$P(t) = f(t) + X(t) \tag{3.19}$$

⁶Change of measure entails the transformation of a probability space.

where $f(t)$ is a deterministic process and $X(t)$ is a stochastic process which takes the following form

$$dX(t) = -\kappa X(t)dt + \sigma dW(t) \quad (3.20)$$

Combining Eqn. 3.19 and Eqn. 3.20, we have

$$d(P(t) - f(t)) = \kappa(f(t) - P(t))dt + \sigma dW(t) \quad (3.21)$$

Eqn. 3.21 represents a mean-reverting dynamic and bears similarity to the Vasicek model. The solution to Eqn. 3.20 is

$$X(t) = X(0)e^{-\kappa t} + \sigma \int_0^t e^{\kappa(s-t)} dW(u) \quad (3.22)$$

since the process reverts around a mean of zero. From Eqn. 3.22, since $X(t) = P(t) - f(t)$, we have

$$P(t) = f(t) + X(0)e^{-\kappa t} + \sigma \int_0^t e^{\kappa(s-t)} dW(u) \quad (3.23)$$

Now given that $X(0) = P(0) - f(0)$, we that⁷

$$E^P(P(t) | F_0) = f(t) + (P(0) - f(0))e^{-\kappa t} \quad (3.24)$$

and

$$Var(P(t) | F_0) = \frac{\sigma^2}{2\kappa}(1 - e^{-2\kappa t}) \quad (3.25)$$

Now the risk-neutral process for the $X(t)$ process is

$$dX(t) = \kappa(\alpha^* - X(t))dt + \sigma d\widetilde{W}(t) \quad (3.26)$$

⁷The third term is dropped because the process reverts around zero.

where $d\widetilde{W}(t)$ is a Q -Brownian motion and where

$$\alpha^* = \frac{-\lambda\sigma}{\kappa} \quad (3.27)$$

Here λ is the market price of risk. The solution to the risk-neutral process followed by $P(t)$ is

$$P(t) = f(t) + X(0)e^{-\kappa t} + \alpha^*(1 - e^{-\kappa t}) + \sigma \int_0^t e^{\kappa(s-t)} d\widetilde{W}(u) \quad (3.28)$$

From Eqn. 3.28, the expectation of $P(t)$ under risk-neutral probabilities is

$$E^Q(P(t) | F_0) = f(t) + X(0)e^{-\kappa t} + \alpha^*(1 - e^{-\kappa t}) \quad (3.29)$$

The value at time zero on a forward contract maturing at T is

$$C^* = e^{-rT} E^Q[P(T) - F(P(T) : 0, T) | F_0] \quad (3.30)$$

Since, C^* , the value of a forward on the spot must be zero to avoid arbitrage, using Eqn. 3.29 we have that

$$F(P(t) : 0, T) = E^Q(P(T) | F_0) = f(T) + (P(0) - f(0))e^{-\kappa T} + \alpha^*(1 - e^{-\kappa T}) \quad (3.31)$$

where

$$\alpha^* = \frac{-\lambda\sigma}{\kappa}$$

Using an alternative approach, Clewlow and Strickland (1999) price electricity derivatives based on forward curve dynamics. Now they define the forward curve dynamics by the following SDE

$$\frac{dF(t, T)}{F(t, T)} = \sigma e^{-\alpha(T-t)} dW(t) \quad (3.32)$$

where $F(t, T)$ is the forward price for a time T delivery for a contract written at time t , σ the volatility of the forward process and α is the rate at which the volatility of the forward process declines. The solution to Eqn. 3.32, obtained by integration, is

$$F(t, T) = F(0, T) \exp \left[-\frac{1}{2} \int_0^t \sigma^2 e^{-2\alpha(T-u)} du + \int_0^t \sigma e^{-\alpha(T-u)} dW(u) \right] \quad (3.33)$$

The spot price process is obtained by setting $T = t$

$$S(t) = F(0, t) \exp \left[-\frac{1}{2} \int_0^t \sigma^2 e^{-2\alpha(t-u)} du + \int_0^t \sigma e^{-\alpha(t-u)} dW(u) \right] \quad (3.34)$$

The natural logarithm of the spot price is normally distributed with

$$\begin{aligned} \ln S(T) &\sim N \left[\ln F(0, T) - \frac{1}{2} \int_0^T \sigma^2 e^{-2\alpha(T-u)} du, \int_0^T \sigma^2 e^{-2\alpha(T-u)} du \right] \\ &= N \left[\ln F(0, T) - \frac{\sigma^2}{4\alpha} (1 - e^{-2\alpha T}), \frac{\sigma^2}{2\alpha} (1 - e^{-2\alpha T}) \right] \end{aligned} \quad (3.35)$$

The price of a call option on the spot price process is

$$C(t, S(t); K, T) = E^Q [P(t, T) \max(S(T) - K, 0) | F_t] \quad (3.36)$$

where $P(t, T) = \exp\left(-\int_t^T r(u)du\right)$. The closed-form solution of a call option on the spot price based on the Black and Scholes (1973) formula is

$$C(t, S(t); K, T) = P(t, T)[F(t, T)N(h) - KN(h - \sqrt{w})] \quad (3.37)$$

where

$$h = \frac{\ln\left(\frac{F(t, T)}{K}\right) + \frac{1}{2}w}{\sqrt{w}}, \quad w = \frac{\sigma^2}{2\alpha}(1 - e^{-2\alpha(T-t)})$$

Clewlow and Strickland (1999) show that the time t price of a European call option, with a strike price K , written on a forward contract that matures at time s is⁸

$$C(t, F(t, s); K, T, s) = E^Q[P(t, T) \max(F(T, s) - K, 0) | F_t] \quad (3.38)$$

The closed form analytical solution for Eqn. 3.38 is

$$C(t, F(t, s); K, T, s) = P(t, T)[F(t, s)N(h) - KN(h - \sqrt{w})] \quad (3.39)$$

where

$$h = \frac{\ln\left(\frac{F(t, s)}{K}\right) + \frac{1}{2}w}{\sqrt{w}}$$

On the merits of using forward prices relative to spot prices for the valuation of contingent claims, the spot dynamics will be influenced by transient factors hence the commonly observed higher volatility of the spot. Such volatility presents considerable challenges from a modelling or a valuation standpoint. On the other hand the forward dynamics are to a lesser extent susceptible

⁸For $s \geq T$.

to transient influences and therefore present a more stable evolution of the underlying. This stability presents a lower degree of challenges for modelling and valuation.

The pricing of weather derivatives under martingale pricing is considered next. Now weather derivatives are contingent claims where the underlying is a weather variable, for example, temperature, humidity, rain or snowfall. These derivatives provide exposure to an upside without corresponding exposure to the downside of specified weather index. As a result weather derivatives can be used to manage the volatility of cash flows that are sensitive to the weather. More commonly weather derivatives are written on the temperature. Weather derivatives have been traded at the Chicago Merchantile Exchange from 1999. Alaton et al. (2002), Brody et al. (2002) and Benth and Benth (2005, 2007) are examples of studies on weather derivatives. All these studies use risk-neutral pricing. The underlying of a temperature derivative is either one of three indices: heating degree-days (HDD), cooling-degree days (CDD) or Cumulative Average Temperature (CAT). Here

$$HDD = \int_A \max(T - T(t), 0)dt \quad (3.40)$$

$$CDD = \int_A \max(T(t) - T, 0)dt \quad (3.41)$$

$$CAT = \int_A T(t)dt \quad (3.42)$$

where $T(t)$ is the average temperature on day t and T is the reference temperature. Derivatives on temperature include futures, forwards and options written on indices in specified cities. To illustrate the broad principles we use the arguments in Benth and Benth (2007). Now they describe the evolution of

temperature using a mean-reverting process as follows⁹

$$dT(t) = dS(t) - \kappa(T(t) - S(t))dt + \sigma(t)dW(t) \quad (3.43)$$

where $S(t)$ captures trend and seasonality. Benth and Benth observe that the Q -dynamics of temperature arrived at by transforming Eqn. 3.43 using Girsanov's theorem is

$$dT(t) = dS(t) + (\lambda(t) - \kappa(T(t) - S(t)))dt + \sigma(t)d\widetilde{W}(t) \quad (3.44)$$

where $d\widetilde{W}(t)$ is a Q -Weiner process and $\lambda(t)$ is the market price of risk. Benth and Benth observe that the solution to Eqn. 3.44, under Q -dynamics, is

$$T(t) = S(t) + (T(t) - S(t))e^{-\kappa(s-t)} + \int_t^s \lambda(u)e^{-\kappa(s-u)}du + \int_t^s \sigma_u e^{-\kappa(s-u)}dW(u) \quad (3.45)$$

Now $T(t)$ under risk-neutral expectations is

$$E^Q[T(s) | T(t)] = S(t) + (T(t) - S(t))e^{-\kappa(s-t)} + \int_t^s \lambda(u)e^{-\kappa(s-u)}du \quad (3.46)$$

and its variance is

$$Var[T(s) | T(t)] = \int_t^s \sigma_u^2 e^{-2\kappa(s-u)}du \quad (3.47)$$

The price of a futures contract on an HDD index is

⁹We assume that this model is correctly specified.

$$F_{HDD}(t : t, s) = E^Q \left[\int_t^s \max(T - T(u), 0) du \mid F_t \right] \quad (3.48)$$

And the price of a futures contract on an CDD index is

$$F_{CDD}(t : t, s) = E^Q \left[\int_t^s \max(T(u) - T, 0) du \mid F_t \right] \quad (3.49)$$

The price of a call option on HDD futures is

$$C_{HDD}(t : t, s) = e^{-r(s-t)} E^Q [F_{HDD}(t : t, s) - K, 0]^+ \mid F_t] \quad (3.50)$$

The price of a call option on CDD futures is

$$C_{CDD}(t : t, s) = e^{-r(s-t)} E^Q [F_{CDD}(t : t, s) - K, 0]^+ \mid F_t]$$

3.5 Contingent Claims on Defaultable Bonds

Jarrow and Turnbull (1995) were among the earlier advocates of the intensity-based approach to valuing defaultable securities and pricing derivatives on these instruments. Subsequent work on intensity-based models include that of Duffie and Singleton (1999), Jarrow and Turnbull (1995, 2000), Jarrow et. al. (1997), Lando (1998), and Madan and Unal (1998). The intensity-based approach finds application in circumstances where there exists a risk of default which is either totally or partially independent of the value of underlying assets. This approach therefore recognizes two main sources of risk i.e. market risk and asset-specific default risk. The recognition of asset-specific default risk distinguishes the intensity-based approach from the earlier structural approach to pricing which was advocated by, among others, Merton (1973, 1977), and Black and Cox (1976).

The intensity-based approach recognizes that at each instant, there is a

possibility that a firm can default on its obligations for reasons other than the value of the underlying asset. This approach takes into account the stochastic dynamics of the value of the underlying asset, and the dynamics of default and recovery. Default is allowed to occur before the maturity of the underlying asset and is triggered by an exogenous process which is either fully or partially independent of the value of the underlying asset. Default times are modeled as a counting process with a stopping time, τ , derived from an intensity process λ .¹⁰ Under intensity-based modelling, the default event is commonly modelled as a poisson distribution as follows

$$P(X(t) = k | F_s) = E \left[e^{-\lambda(t-s)} \frac{(\lambda(t-s))^k}{k!} \right] \quad (3.51)$$

where $X(t)$ denotes the number of defaults in the interval $[s, t]$ and λ is a constant default intensity. Assuming a non-constant default intensity, $\lambda(u)$, the probability that the stopping time, τ , exceeds an arbitrary time, t , is

$$P(\tau > t | F_s) = E \left[\exp \left(- \int_s^t \lambda(u) du \right) \right] \quad (3.52)$$

Now the value of a non-defaultable zero-coupon bond written at time, s , and maturing at time, t , under risk-neutral probabilities is

$$B_n(s, t) | F_s = E^Q \left[\exp \left(- \int_s^t r(u) du \right) \right] \quad (3.53)$$

where r is the instantaneous interest rate. The value of a defaultable bond under-risk neutral expectations is

¹⁰It is however noted that this dynamic contrasts the phenomenon that is subject of this study where the useful life of the underlying asset can extend beyond first stopping time, τ , and even oscillate variously between active and inactive states. We discuss this contrast and an approach for capturing this dynamic in Chapters 5 and 6.

$$B_d(s, t) | F_s = E^Q \left[\exp \left(- \int_s^t r(u) du \right) \right] * E^Q \left[\exp \left(- \int_s^t \lambda(u) du \right) \right] \quad (3.54)$$

Therefore allowing for independence between r and $\lambda(u)$, the value of the defaultable bond is¹¹

$$B_d(s, t) | F_s = E^Q \left[\exp \left(- \int_s^t (r(u) + \lambda(u)) du \right) \right] \quad (3.55)$$

Jarrow and Turnbull, Akat et. al (2006) and Akat (2007) develop a model for valuing defaultable securities where the underlying value is defined by a Geometric Brownian Motion. In Akat (2007), the value of the defaultable security is defined as follows

$$dS(t) = uS(t)dt + \sigma S(t)dW(t) \quad (3.56)$$

Given a constant exogenous default intensity, λ , the risk-neutral process defining the evolution of the underlying assets is

$$S(t) | F_s = S(s) \exp \left((r + \lambda^* - \frac{1}{2}\sigma^2)t + \sigma d\widetilde{W}(t) \right) \quad (3.57)$$

where λ^* is a risk-neutral intensity process and $d\widetilde{W}(t)$ is a Q -Brownian Motion. The ratio λ^*/λ represents the risk premium associated with the risk of default (Duffie, 2002). The price of a European digital option which pays \$1 at maturity if $S(T) > K$ or otherwise zero is given by

$$P(t, s) = e^{-(r+\lambda^*)(T-t)} \left(N(d_+(\tau)) - \left(\frac{s}{K} \right)^{1-\frac{2(r+\lambda^*)}{\sigma^2}} N(d_-(\tau)) \right) \quad (3.58)$$

¹¹See Lando (1998) and Elliott et. al (2000)

where

$$d_{\pm} + (\tau) = \frac{\pm \frac{s}{K} + (r + \lambda - \frac{1}{2}\sigma^2)\tau}{\sigma\sqrt{\tau}} \quad (3.59)$$

3.6 Summary

The review in this chapter has taken an excursion from the Black and Scholes (1973) model to its enhancements in Merton (1973). We considered Black (1976) who showed how futures prices can be used to price contingent claims, based on arbitrage arguments. The contribution by Black is particularly important in commodity markets where spot prices may be ambiguous but where futures and forward prices are either observable or can be reasonably inferred. Cox et al. (1979) not only showed how arbitrage arguments can be structured in discrete time but also quite importantly introduced the concept of risk-neutral valuation. Harrison and Kreps (1979), and Harrison and Pliska (1981, 1983) more rigorously developed the concept of risk-neutral valuation and extended its application to continuous time. Now concepts introduced by Black (1976) and the risk-neutral pricing principles constitute some of the fundamental cornerstones for pricing commodity derivatives. In applying risk-neutral pricing, the market price of risk has been shown to be a handle which links P -dynamics to Q -dynamics. We reviewed the application of risk-neutral pricing to the pricing of derivatives where the underlying is either a non-financial or a non-tradable asset – these included electricity and weather derivatives. We considered some of the key arguments in valuing these derivatives and examined how these can inform derivative pricing in telecommunication capacity access markets.

On the merits of using forward prices relative to spot prices for the valuation of contingent claims, it has been argued that the spot dynamics will be generally influenced by transient factors hence the commonly observed volatility of the spot. Such volatility presents considerable challenges from a modelling or a valuation standpoint. On the other hand the forward dynamics are to a

lesser extent susceptible to transient influences and therefore present a more stable evolution of the underlying. This stability presents lesser challenges for modelling and valuation.

Chapter 4

RESEARCH DESIGN AND ANALYTICAL FRAMEWORK

4.1 Introduction

At a first level of enquiry, case study research is used to identify the dynamics that describe downstream value in telecommunication capacity platforms. This background is used to develop a framework for testing the symmetry of cost-based access prices from the standpoint of option pricing theory. The data used in this study is based on UK evidence from the analogue and ASDL capacity access platforms. On the analytical methods, this study uses a two-prong approach – a numerical method, Monte Carlo simulation and closed-form analytical solutions. Monte-Carlo simulation is used because of its versatility in computing high-dimensional integrals and valuing complex derivatives defined by multi-dimensional stochastic processes. The closed-form analytical solutions first, provide a basis for checking the results from the numerical methods. Second, these solutions generalize the results and provide an option-theoretic framework for pricing access where third parties have the leverage of adapting to downstream stochastic value. In both cases the analysis is founded on the dynamics of the evolution of the average downstream value of an activated exchange line, including its drift and volatility; the intensity of exchange line activation, including its drift and volatility; the price of access to the Subscriber Network; and the price of market risk, and that of the risk of default.

Section 4.2 of this chapter covers the philosophical foundations of this study and includes a discussion of positivism and the hypothetico-deductive method. Section 4.3 discusses the research design, including the structure of the study and the sources of data. Section 4.4 discusses the first analytical method used in this study, Monte Carlo simulation. Section 4.5 covers a discussion of efficiency enhancing techniques, with respect to Monte Carlo simulation, including

antithetic variates, control variates, moment matching, stratified sampling, importance sampling and low discrepancy sequences. Section 4.6 provides an overview of the second method used in this study, closed-form analytical solutions.

4.2 Philosophical Foundations

4.2.1 Positivism

The broad philosophical foundation of this study is positivism. Within this broad framework, this research draws on the hypothetico-deductive principle. Under positivism, the phenomenon under study is conceptualized as being quantifiable. While its proponents have argued that positivism brings with it the virtue of objectivity, there are questions which challenge this view. These questions include whether the predispositions of researchers affect their synthesis of the external reality. Or whether the construction of knowledge is pursued around existing paradigms and whether therefore the ensuing knowledge is neutral and free from the social conventions of the day. Other concerns centre around whether the linguistic apparatus used in research is proactive in generating the reality that is represented. This section considers these questions in discussing the strengths and weaknesses of positivism as a philosophical foundation in the context of this study.

Positivism finds its roots in the rationalist and empiricist traditions of the pre-Enlightenment period. The rationalists, for example, Rene Descartes emphasized the sceptical contemplation of the external reality as a basis for constructing knowledge. Perhaps the most important influence of the rationalists' traditions on positivism was the presumption of Cartesian dualism which conjectures that the external reality exists independently of the human mind. The primary epistemic stance of empiricists including, for example, John Locke and Francis Bacon, was that warranted knowledge flowed from test experience. In other words observation of instances of a phenomenon was the only basis for

generating knowledge. Positivism took its highest expression in the work of the logical positivists – a group associated with the social intellectuals in the 1920s and 1930s.

Positivism conjectures that the techniques of observation, measurement and quantification are the basis for the construction of warranted knowledge. Positivism emphasizes that observation and empirical testing, free from preconceptions, are the means through which the external reality can be explained. Positivists argue that science must concern itself with the generation of factual knowledge and that which cannot be derived from empirical facts cannot constitute the basis for constructing knowledge. As a result claims which are non-verifiable are necessarily excluded from the domain of warranted knowledge.

The vulnerabilities of positivism lie in its absolutist foundations. A competing philosophy, which is commonly referred to as relativism, in the main, argues that science cannot discover absolute truths. Relativists' epistemology counters the deterministic foundations of positivism and holds that knowledge claims are context-dependent. More specifically relativists argue that: there does not exist a neutral language for projecting science; truth can only be relative to, for example, culture, language and paradigms. Therefore empirical observations are only intelligible within the context of the underlying circumstances. The next section takes a closer look at these arguments.

4.2.2 Challenging Positivism

Relativists including, among others, Immanuel Kant, Thomas Kuhn, Max Weber, Jacques Derrida, Michel Foucault and Jurgen Habermas challenge the absolutist traditions of positivism. For example, Kant argued against the positivists' stance that suggests that there exists an external reality which is separate from the human mind and which can be accessed directly through human cognitive structures. Kant (1965), in his *Critique of Pure Reason*, observes that the human mind is not a passive receptor of the world outside it. Rather constructs

of the mind are influenced by cognitive predispositions. These constructs are therefore shaped by what Kant refers to as *a priori* contents of the human mind which include, for example, beliefs, culture and knowledge. Therefore, according to Kant, the human mind is not a passive receptor of information or data from the world outside it but is active in constructing the perceived world.

Kant distinguishes between *noumena* and *phenomena* and suggests that the former represents the external world which is independent of human cognition. This external world cannot however be accessed directly by human cognition and is therefore unknowable to the human mind. On the other hand *phenomena* represents the pseudo-reality created by the human mind. Any such creation of the mind is prone to noise from cognitive structures. Therefore while *phenomena* is accessible to the human person, *noumena* is not. This observation has two important implications. First, scientific knowledge is limited to knowledge of *phenomena*. Second, because scientific knowledge must necessarily be relative to the predispositions of its proponents, there cannot be absolutes in knowledge claims.

Kuhn also counters the absolutist traditions of positivism. He argues that what is considered as the truth or warranted knowledge is always relative to a paradigm. Paradigms are however transitory and see shifts through time. Kuhn (1970), in his book, *The Structure of Scientific Revolutions*, observes that scientific knowledge is driven by paradigms of the day and reflect social conventions. These conventions define the boundaries of what is acceptable within a scientific community. In other words, paradigms reflect the inclinations of such a community, their way of looking at issues and their views of what is deemed as contemporary. This is however confining as researchers work around and within what is deemed acceptable within their community.

Kuhn observes further that the development of knowledge is subject to paradigm shifts. Through the passage of time the process of knowledge creation is characterized by competing paradigms from which emerges a dominant paradigm, and which provides the basis for research at the time. Over time

however dominant paradigms lose their versatility and new competing paradigms emerge. Then, here too emerges a dominant paradigm. Kuhn postulates that because knowledge is constructed around paradigms which are transitory by their nature, knowledge claims cannot be absolute. Knowledge constructed around paradigms cannot be absolute because researchers do not have a neutral standpoint from which to observe the reality around them. As it were concepts and knowledge claims are driven by paradigms of the day. Therefore a paradigm-neutral observational standpoint does not exist. Without such neutral observational standpoint, what holds is the consensus theory of truth. The proponents of this theory suggest that truth claims cannot be anything more than the product of the views of those who subscribe to a particular paradigm or a frame of reference. Truth claims are therefore pronouncements that are accepted in particular social contexts, and such claims can only be relative.

Post-structuralists' epistemology further counters the positivists' claims on absolute truths. One of the key arguments of the post-structuralists, for example Derrida, following the "linguistic turn", is that language is value-laden. However knowledge is constructed through language. Because language is not neutral, scientific observations cannot be objective. Accordingly post-structuralists reject the positivist conjecture that there exists an objective basis for capturing reality through the application of a neutral observational language. According to the post-structuralists' epistemology, concepts (signifiers) are used to communicate mental concepts (signified) – the relationship between the two is however deemed to be arbitrary. A mental concept can be represented by a tier of words. Such tier can however be represented by alternative sets of words. This gives rise to a profusion of meanings. Therefore the linguist apparatus is proactive in generating the reality that is represented. As a result, according to post-structuralists' epistemology, unmediated access to reality is a myth because language cannot definitively represent reality.

Despite the criticisms levelled against it, positivism brings the credibility of scientific methods to social sciences. The construction of knowledge in social

sciences is nevertheless impacted by influences including, among others, the predisposition of the researcher, the socialization of science and the uncontrollability of language. The gravity of these influences will vary depending on the object of study. At one extreme, the use of positivistic methods may well achieve Keat and Urry's (1982) conception of science as an objective and rational enquiry which aims at true explanatory knowledge of an external world, based on empirical evidence. At the other extreme the impact of the said three influences may take a firmer hold and give meaning to Rorty's (1982) observation that truth is a changeable artefact or Alvesson and Willmot's (1996) observation that knowledge remains the product of particular values that give it meaning. Ultimately while the ideal scientific method may not exist in social sciences, a researcher must carefully consider how the nature of the research sits with the vulnerabilities of the positivistic methods. Whatever the case researchers must humble themselves from lofty truth claims and see their findings from positivistic methods as truths that are relative to the influences on their studies.

4.2.3 Hypothetico-Deductive Method

Popper (1959), in his work, *The Logic of Scientific Discovery*, counters the broad premise of positivism's inductive and verificationist principles arguing that these principles do not recognize the place of refutations of existing theories as legitimate contributions to the construction of knowledge. Popper's views here are based on the premise that there is nothing absolute about knowledge and that the results of scientific activity can never be certain since science cannot produce definitive accounts of the truth but only approximations of it. At any time a theory only reflects the distance travelled in a particular discipline. New evidence drives out weak theories and new theories emerge. Knowledge creation is therefore a sequence of conjectures and refutations. Through this sequence of conjectures and refutations knowledge evolves as more versatile approximations of the truth. Theories should therefore be held as tentative con-

jectures until falsified. But such falsification must be underpinned by empirical evidence. A theory is refuted if it does not hold to the evidence. Bertrand Russell (1948), in his work, *Human Knowledge, Its Scope and Limits*, encapsulates this in a most compelling way:

One day a chicken was hatched. By chance it stumbled upon corn and water. It was a happy chick. The next day it happened again and again the next day. Being an intelligent chicken, it considered the possibility that supplies might stop and wondered whether it was necessary to take precautions. It decided to investigate the world to see whether, given a large number of cases and a variety of conditions, there were grounds to suppose that the pattern of events so far witnessed would continue in future. The benefit would be that the no precaution against the non-supply of corn and water need be taken. After months of careful observations and noting that differences in the weather, configuration of the stars, beings encountered, mood and many other things did not stop supplies, the chicken concluded that the world was truly a wonderful place. The very next day, everything changed. It was December 24.

Turning to the background of this study, FL-LRIC is advanced in a considerable body of literature as an effective instrument for incentive regulation in telecommunication capacity access networks. Proponents of FL-LRIC argue that its tenets provide appropriate incentives for productive and dynamic efficiency. It is argued that access seekers pay a price, and access providers receive a price that correspond to the costs that the latter imposes on access infrastructure. Consequently, access seekers bear a cost that is equivalent to the social cost of supply. In this respect, it is argued that FL-LRIC, is not only equitable to the access provider but induces entry from access seekers who are either equally or more efficient than the access provider in the intermediate services market (Sappington and Weisman, 1996; Vogelsang, 2003). In this study we test whether the hypothesized neutrality of FL-LRIC can stand up to the

evidence.

4.3 Research Design

4.3.1 Case Study Research

Given the complexity of the phenomenon being studied, at a first level of enquiry, we use case study research to define the dynamics that describe downstream value in the telecommunication capacity platforms. This understanding is used to develop models that describe the evolution of such value and also develop models that value the different dimensions of the flexibility to adapt to downstream stochastic processes. These models are subsequently used to test the symmetry of cost-based access prices. Based on the plausibility of the logic of the analysis, the findings are generalized as theoretical propositions. Their extrapolation from case to case is based on logical inference. Now case studies have been widely used in research for explanatory purposes, in respect of both theory building and theory testing (Thomas, 2004). Thomas observes that case studies can generate theoretical insights that are closely grounded in real experience, in contrast to speculative theorizing.

Yin (2003) defines a case study as an empirical inquiry into a contemporary phenomenon within its real-life context. Mitchell (1983) characterizes a case study as an examination of an event (or a series of events) which exhibits the operation of some identified theoretical principal. Collis and Hussey (2003) define a case study as an extensive examination of a single instance of a phenomenon of interest. Eisehardt (1989) argues that case studies utilize concepts that are validated by their close contact with empirical reality and are therefore capable of yielding theories that are versatile. Yin (2003) observes that case studies can be used to explain the presumed casual links in real-life interventions that are too complex for the survey methodology. Case studies have been an important research methodology in business (Ghauri and Gronhaug, 2002). In economics case studies have been used to investigate the structure of industries or the

economies of cities and regions (Yin, 2003). In such cases, the choice of case studies as a research tool is driven by the need to understand complex phenomenon and provide in-depth understanding of the holistic nature and complexity of real-life events.

Citing Kaplan (1964), Ryan et al.(1992) illustrate the relevance of case studies with reference to the pattern model of explanation. In such a model, the system and its context form the basis of explanation. The relationship between the various parts the system and the system's relationship with the larger system of which it is a part (its context) serve to explain the system. Ryan et al. observe that whereas the inductive model of explanation provide predictions of occurrences at the empirical level, based on more abstract general laws or theories, it does not provide an explanation of these occurrences. These statistical generalizations indicate statistical regularities which may or may not apply in specific circumstances. The explanations from the pattern model aid a fuller understanding of the world that we live in. Ryan et al. further observe that it is inappropriate to study individual parts of social systems taken out of context because these systems develop a characteristic wholeness or integrity. Accordingly, a holistic research methodology seeks to explain this holistic quality and locate particular social systems in their practical context.

A key criticism of case study research is that it provides little basis for scientific generalizations (Thomas, 2004). Arguing to the contrary, Yin (2003) observes that while case studies, like experiments, cannot be generalized to populations or universes, they can however be generalized to theoretical propositions. Therefore a case study, like an experiment, does not represent a sample but rather provides a basis for analytical generalizations but not statistical generalizations. Arguing for case study research, Smith (1991) citing Worsley et al. (1970) writes, "the general validity of the analysis does not depend on whether the case being analysed is representative of other cases of its kind, but rather upon the plausibility of the logic of the analysis." On the same subject Ryan et al. citing Mitchell (1983), observe that "logical inference is epistemo-

logically quite independent of statistical inference." Mitchell (1983) argues that "the process of inference from case studies is only logical or causal and cannot be statistical and extrapolability from any one case study to similar situations in general is based only on logical inference. We infer that the features present in the case study will be related to a wider population not because the case is representative but because the logic of the analysis is unassailable."

Case study research gains more acceptance as a method of research given the view of some researchers that a considerable body of management research deviates from the complexity of reality and therefore leans towards being irrelevant. Starkey and Madan (2001) examine the relevance gap in management research and argue that knowledge should inform action; and action becomes knowable if we better understand the underlying principles linking cause and effect. The authors add that researchers should engage more with the complexities of practice and argue that the defining characteristic of management research should be its applied nature.

John and Duberly (2000) observe that the focus of management research has become narrower and narrower in search for causal relationships to the extent that the propositions being tested do not reflect the complexity of the real world. They conclude that the result can be propositions which apply in such narrow circumstances that they bear little relationship to reality and therefore have remote effectiveness as a basis for understanding or controlling social phenomenon. Di Maggio (1995) decries management research whose thrust is the search for covering laws and which relies on a view of scientific progress as being a kind of a "R² sweepstake."

4.3.2 Structure of the Study and Data Sources

The data required for this study is that which describes the downstream stochastic value in telecommunications access markets. This primarily includes data on the evolution of tariffs, and the price of access and conveyance. To the best of the knowledge of the researcher, the UK is the only market where a

substantial part of this data is in the public domain. This factor underpinned the decision to base the study on UK evidence. Now the capacity access market in the UK comprises the following platforms – analogue, ISDN2, ADSL (Symmetric) and ADSL (Asymmetric). These platforms are differentiated, in the main, by capacity (bandwidth), hence their differences in service capabilities. Analogue lines provide capacities of up to 56 kbit/s, ISDN2 64 kbit/s over single-digital channels and 128 kbit/s over double-bonded digital channels. ADSL Symmetric and Asymmetric platforms provide capacities higher than 128 kbit/s. Symmetric access provides equal upstream and downstream bandwidth while asymmetric access provides maximum downloading capacity but a lower uploading capacity. This research covers the residential analogue and ADSL (asymmetric) platforms. This coverage constitutes about 62% by value of the analogue access market and 43% by value of the ADSL access market at the time of the study.¹

With respect to the analogue platform, this study is based on data from the period September 1999 to June 2007. We use September 1999 as the starting point because it is the earliest period in respect of which the required data is available in the public domain. The data is sourced from Oftel's² *Market Information Fixed Update* in respect of the period July 1999 to June 2003 and Ofcom's *Market Data Tables* for the period July 2003 to June 2007. The price of access to the Subscriber Access Network can be obtained from either BT's regulatory accounts or Ofcom (2005), *Wholesale Line Rental: Reviewing and Setting Charge Ceilings for WLR Services*. The price of conveyance, including unit costs and usage factors, is obtained from BT's regulatory accounts. With respect to the ADSL platform, this study is based on data from the period July 2000 to December 2008. Here July 2000 is used as the starting point because it is the earliest period in respect of which the required data is available in the public domain. The tariff data is obtained from databases managed by *Point*

¹A more expansive coverage has not been opted for because of the limitations on the length of this thesis.

²Ofcom's predecessor

Topic and Pure Pricing,³ and from individual service providers. The price of conveyance in the core network is obtained from BT's *Wholesale Broadband Services Price List*. As with the analogue platform, the price of access to the Subscriber Access Network can be obtained from either BT's regulatory accounts or Ofcom (2005), *Wholesale Line Rental: Reviewing and Setting Charge Ceilings for WLR Services*.

We use data points from the period September 1999 in the case of the analogue platform, and from July 2000 in the case of the ADSL platform, to calibrate the SDEs defining downstream value and use these as a basis for valuing the underlying contingent claims. The contingent claims are defined as bundles of rights through time and space. We restrict the valuation of the contingent claims to a 12-month period, a conservative estimate of a regulatory lag. A regulatory lag is the period during which the regulated access price remains fixed. In essence therefore this is the period within which the equivalent of the strike price, from a contingent claim perspective, remains fixed. In practice, a regulatory lag will however usually be between 1 and 5 years. In this study we take the conservative limit of one year. In both the analogue and ADSL platforms, the sources referred to above only contain quarterly data. Faced with this constraint, monthly data points are obtained through interpolation. Whilst this adds noise to the data set, this approach has been used by researchers, for example, Henisz and Zelner (2001), when faced with similar constraints.

4.4 Monte Carlo Simulation

4.4.1 Basis as a Numerical Method

A contingent claim in the telecommunications access market is driven by a complex set stochastic processes. Based on this consideration, this study uses the Monte Carlo Method as part of a two-prong analytical approach. The Monte Carlo method was particularly appealing in the earlier days of the study

³Both firms maintain databases on broadband retail tariffs.

when the feasibility of using closed-form analytical solutions seemed unlikely because of the complexity of the dynamics studied. From the standpoint of option pricing theory, the value of a contingent claim is equivalent to the discounted risk-neutral expectation of the cash flows from the derivative security. Computing the value of a contingent claim is therefore equivalent to computing an integral over the space defined by the underlying value generating process. The computational complexity of evaluating such integral is exponential to the dimensions of the space defining value (Barraquand, 1995). The Monte Carlo method is the only tractable approach for computing high dimensional integrals (Barraquand and Martineau, 1995). The Monte Carlo method presents a tool for valuing complex derivatives defined by, for example, multi-dimensional stochastic processes, path dependence and early exercise, where closed-form analytical solutions may not be feasible

Boyle (1977) was among the first proponents of the Monte Carlo method as a numerical method for the valuation of derivative securities. Boyle shows how Monte Carlo simulation, when reinforced with appropriate variance reduction techniques, provides solutions which approximate those arrived at by closed-form analytical solutions. The basis of the Monte Carlo method as a tool for numerical integration is as follows - take a function $h(u)$ where the realizations $u(i)$ are independent, identically distributed and defined by some *pdf* $f(u)$. The Monte Carlo method provides a basis for evaluating the following integral

$$E[h(u)] = \int_A h(u)f(u)du \quad (4.1)$$

The Monte Carlo method in effect computes an integral over the space defining value and thereby provides a basis for deriving the value of a contingent claim described as an expectation (see Boyle, 1977; Trigeorgis, 1996; Boyle et al., 1997; Galanti and Jung, 1997). The Monte Carlo method can be extended to compute multi-dimensional integrals.

The Monte Carlo method has been used as a numerical method for the

valuation of contingent claims by a large number of researchers. For example, Hull and White (1987) use the Monte Carlo method to value contingent claims where the volatility of the underlying asset is stochastic. Kemna and Vorst (1990) use the Monte Carlo method to value path-dependant contingent claims where the value of each claim depends on the average value of the underlying asset in a defined period preceding the derivative's maturity. Here the holder of the security is entitled to the higher of such average value and a straight bond value with the exercise price being the nominal value of the bond. Barraquand (1995) apply the Monte Carlo method to value European contingent claims defined by multiple sources of uncertainty with the algorithm proposed being capable of valuing claims where the value of the underlying asset is driven by up to 100 sources of risk. Barraquand uses quadratic re-sampling, also referred to in the literature as Moment Matching (see Boyle et al, 1997), to improve the efficiency of their method.

Barraquand and Martineau (1995) develop an approach for valuing an American contingent claim whose value depends on multiple sources of uncertainty. They apply the Monte Carlo method to a state space partitioning technique that circumvents the curse of dimensionality. Using one underlying asset, Barraquand and Martineau, show that their results correspond to the Black and Scholes closed-form analytical solution for both call and put options. Barraquand and Martineau, extend their work to 3 and 10 underlying assets and show that their method generates results which correspond to classical integration methods. Barraquand and Martineau successfully apply their method to the valuation of contingent claims with over 400 dimensions of uncertainty.

Broadie and Glasserman (1997) propose an algorithm based on the Monte Carlo method for valuing contingent claims with early exercise features. Their algorithm, which combines the use of two estimators (with high and low biases), is capable of valuing contingent claims with multiple state variables, path dependencies and early exercise. Grant et al. (1997) use the Monte Carlo method to price contingent claims based on the average price of the underly-

ing assets and where early exercise is feasible. They combine forward-looking simulation with backward-moving recursive dynamic programming. Longstaff and Schwartz (2001) develop a method for valuing options, by simulation, using a Simple Least-Squares Approach. This method is capable of valuing options defined by multiple factors. Ibanez (2004) applies the Monte Carlo method to value multiple exercise contingent claims. These claims in essence represent a portfolio of buying and selling rights where a specified number of rights can be exercised in a defined window, and where one right can be exercised per period for a finite number of exercise dates. Under these contracts the value of contingent claims are a function of the stochastic processes that drive value but also necessarily a function of the number of exercise rights conferred to the purchaser.

4.4.2 Simulating the SDEs Defining Value

The SDEs describing the evolution of downstream value are based on the observations discussed in Section 4.3.2. Maximum Likelihood Estimation is used to calibrate the SDEs and the value of the underlying contingent claims are estimated using risk-neutral valuation principles. An intensity-based approach is used to account for the effect of the stochastic dynamics of exchange line activation. The price of market risk and the price of the risk of default are used as handles that define the martingale equivalents of the process that generates value. To illustrate, taking the example of the analogue platform, the evolution of downstream value of an activated line is defined as follows⁴

$$dS_a(t)^* = \gamma_{as}(\alpha_{as}(t) - S_a(t)^*)dt + \sigma_{as}dW(t)^{as} \quad (4.2)$$

where $S_a(t)^*$ represents the log of the average downstream value of an activated exchange line. The postscript/subscript a distinguishes the analogue platform from the ADSL platform and the postscript/subscript s distinguishes

⁴The arguments in Eqn. 4.2 - Eqn. 4.9 are developed more fully in Chapter 5.

the parameters of $S_a(t)^*$ from those of other processes in the analogue platform. Now here $\alpha_{as}(t)$ is the level around which the process fluctuates, γ_{as} the speed of reversion to the mean, σ_{as} the volatility of the noise term and $W(t)^{as}$ is a Wiener process. The seasonal variation exhibited by $S_a(t)^*$ is described as an ordinary trigonometric function, as follows

$$\alpha_{as}(t) = \beta_s + \xi_s(t) + \eta_s \sin(\omega_s t + v_s) \quad (4.3)$$

where $\beta_s, \xi_s, \eta_s, \omega_s$ and v_s are constants. Here $\xi_s(t)$ captures the drift of $S_a(t)^*$ through time. Now $\beta_s, \eta_s, \omega_s$ and v_s capture the other usual parameters of a trigonometric function. The process describing the evolution of $S_a(t)^*$ under risk-neutral expectations is given by

$$dS_a(t)^* = \gamma_{as} \left(\alpha_{as}(t) - S_a(t)^* - \frac{\lambda_1 \sigma_{as}}{\gamma_{as}} \right) dt + \sigma_{as} d\widetilde{W}(t) \quad (4.4)$$

where λ_1 is the market price of risk and $d\widetilde{W}(t)$ is a Q -Weiner process. The expectation with respect to Eqn. 4.4 is

$$E^Q[S_a(t)^* | F_s] = (S_a(s)^* - \alpha_{as}^*(s))e^{-\gamma_{as}(t-s)} + \alpha_{as}^*(t) \quad (4.5)$$

where

$$\alpha_{as}^*(t) = \beta_s + \xi_s(t) + \eta_s \sin(\omega_s t + v_s) - \frac{\lambda_1 \sigma_{as}}{\gamma_{as}}$$

Or

$$\alpha_{as}^*(t) = \alpha_{as}(t) - \frac{\lambda_1 \sigma_{as}}{\gamma_{as}} \quad (4.6)$$

The variance of $S_a(t)^*$ is

$$Var[S_a(t)^* | F_s] = \frac{\sigma_{as}^2}{2\gamma_{as}} (1 - e^{-2\gamma_{as}(t-s)}) \quad (4.7)$$

Now the risk-neutral dynamics of $S_a(t)^*$ can be simulated based on knowledge of Eqn. 4.5 and Eqn. 4.7 where the noise associated with the process, in the interval $[s, t]$, is represented as follows

$$e_s(t) | F_s = \sigma_{as} \sqrt{\frac{(1 - e^{-2\gamma_{as}(t-s)})}{2\gamma_{as}}} \varepsilon(t) \quad (4.8)$$

where $\varepsilon(t)$ is a random variable described by $N(0, 1)$. Similarly the process $F(S_a(t); t, t)$ can be simulated based on knowledge of its mean and variance.

Turning to model calibration, to illustrate, the parameters of $S_a(t)^*$ are calibrated using a two-step procedure.⁵ The parameters of the trigonometric function $\beta_s, \xi_s, \eta_s, \omega_s$ and ν_s are first determined through least squares estimation using Matlab. These parameters are estimated such that the sum of squares i.e.

$$\sum_{t=1}^n \| (S_a(t)^* - \alpha_{as}(t))^2 \| \quad (4.9)$$

is minimized.⁶ Letting $\chi_a(t) = S_a(t)^* - \alpha_{as}(t)$, we observe data $\chi_a = \{\chi_a(t_0), \chi_a(t_1), \dots, \chi_a(t_n)\}$ drawn from a population where $\chi_a(t_i)$ are independent and identically distributed. Next the parameters that define mean reversion i.e. $\gamma_{a\chi}$ and $\sigma_{a\chi}$ are estimated using Maximum Likelihood Estimation (MLE). We use MLE to solve for $\theta_{a\chi} = \{\gamma_{a\chi}, \sigma_{a\chi}\}$ such that the likelihood of observing the sample data is maximized. This is achieved by maximizing the following likelihood function. The log-likelihood function, the development of which is explained more fully in Chapter 5, is as follows

⁵This has been done to avoid over-fitting given the relatively low number observations, thereby giving emphasis to the overall trend. The one-step alternative approach is subsequently discussed in Chapter 5.

⁶For $t = 1 \dots n$

$$\begin{aligned}
& L(\chi_a(t_0), \chi_a(t_1), \dots, \chi_a(t_n); \gamma_{a\chi}, \alpha_{a\chi}, \sigma_{a\chi}) = \\
& -\frac{\gamma_{a\chi}}{2} \log\left(\frac{\sigma_{a\chi}^2}{2\gamma_{a\chi}}\right) - \frac{1}{2} \sum_{i=0}^{n-1} \log(1 - e^{-2\gamma_{a\chi}(t_{i+1}-t_i)}) - \\
& \frac{\gamma_{a\chi}}{\sigma_{a\chi}^2} \sum_{i=0}^{n-1} \left(\frac{(\chi_a(t_{i+1}) - \alpha_{a\chi}) - (\chi_a(t_i) - \alpha_{a\chi})e^{-(t_{i+1}-t_i)}}{(1 - e^{-2\gamma_{a\chi}(t_{i+1}-t_i)})} \right)^2
\end{aligned} \tag{4.10}$$

With respect to the analogue platform, based on evidence from the period September 1999 to June 2007, we describe the evolution of exchange line activation as an Ito process, as follows

$$\frac{d\rho_a(t)}{\rho_a(t)} = \phi_{a\rho} dt + \sigma_{a\rho} dW(t)^{a\rho} \tag{4.11}$$

where $\phi_{a\rho}$ is the drift of the process, $\sigma_{a\rho}$ its volatility and $dW(t)^{a\rho}$, is a Wiener process. The expectation with respect to Eqn. 4.11 above is as follows

$$E[\rho_a(t) | F_s] = \rho_a(s) \exp\left[\left(\phi_{a\rho} - \frac{1}{2}\sigma_{a\rho}^2\right)(t-s)\right] \tag{4.12}$$

and the variance of the process is

$$Var[\rho_a(t) | F_s] = \sigma_{a\rho}^2 \rho_a(s)^2 (t-s) \tag{4.13}$$

Now Eqn. 4.12 and Eqn. 4.13 form the basis of simulating $\rho_a(t)$. From Eqn. 4.13 the noise term of the process, in the interval $[s, t]$, is

$$e_\rho(t) | F_s = \sigma_{a\rho} \sqrt{(t-s)} \varepsilon(t) \tag{4.14}$$

where ε is a random variable from a standard normal distribution. Turning to the calibration of $\rho_a(t)^*$, we observe data $\rho_a = \{\rho_a(t_0)^*, \rho_a(t_1)^*, \dots, \rho_a(t_n)^*\}$ drawn from a population where $\rho_a(t_i)^*$ are independent and identically distributed. We use the Maximum Likelihood Estimation to solve for $\theta_{a\rho} = \{\phi_{a\rho}, \sigma_{a\rho}\}$ such that the likelihood of observing the sample data is maximized. The relevant log-likelihood function, the development of which is explained more fully in Chapter 5, is as follows

$$\begin{aligned}
& \log p(\rho_a(t_0)^*, \rho_a(t_1)^* \dots \rho_a(t_n)^*; \phi_{a\rho}, \sigma_{a\rho}^2) = \\
& -\frac{1}{2} \sum_{n=1}^n \left[\log[2\pi\sigma_{a\rho}^2(t_i - t_{i-1})] + \frac{\left(\rho_a(t_i)^* - \rho_a(t_{i-1})^* - \left\{\phi_{a\rho} - \frac{\sigma_{a\rho}^2}{2}\right\}(t_i - t_{i-1})\right)^2}{\sigma_{a\rho}^2(t_i - t_{i-1})} \right] \\
& + \log p(\rho_a(t_0); \phi_{a\rho}, \sigma_{a\rho}^2) - \sum_{i=0}^n \log \rho_a(t_i)
\end{aligned} \tag{4.15}$$

Under the assumption that the risk associated with $p_a(t)$ is incorporated in $S_a(t)$, knowing that a rational access seeker will align entry and exit such that for any time interval $F(S_a(t); t, t) > K_a$, the value of a contingent claim on the $S_a(t)$ process incorporating the stochastic intensity of line activation, is

$$\begin{aligned}
& C(s, F(s, t); K_a, t) = \\
& [E^Q[(S_a(t); t, t) - K_a, 0]^+ * E[\rho_a(t)]] * e^{-r(t-s)}
\end{aligned} \tag{4.16}$$

where $E[\rho_a(t)]$ is the intensity of exchange line inactivation under objective measures. With respect to the ADSL platform, the SDEs describing the evolution of downstream value are based on observations from January 2000 to December 2008. Here too Maximum Likelihood Estimation is used to calibrate the SDEs, and the value of the underlying contingent claims are estimated using risk-neutral valuation principles. And an intensity-based approach is used to value contingent claims on the process generating value. The price of market risk and the price of the risk of default are used as the handles that define the martingale equivalents of the process that generates value.

4.5 Variance Reduction Techniques

4.5.1 General

A Variance Reduction Technique (VRT), Antithetic Variates, was employed during the earlier stages of this study to improve the efficiency of estimates from the numerical methods. This however resulted in modest improvement

of the results because of the low volatility of downstream exhibited by the quarterly data used in this study. As discussed more fully in Section 8.2, the use of quarterly data, while providing a basis for first-order approximations, conceivably understates actual volatilities, hence perhaps therefore improperly marginalizing the usefulness of VRTs in this study. Enhanced levels of volatility of downstream value may well require VRTs to improve the efficiency of the estimates from numerical methods. Given this, VRTs are discussed in this section to provide an appreciation of their potential relevance in the face of more disaggregated data.

4.5.2 Antithetic Variates

Antithetic and Control Variates are the more traditional techniques for improving the efficiency of the Monte Carlo method. Other techniques have more recently found application in the literature - these include moment matching, importance sampling and conditional Monte Carlo (Boyle et al. 1997). We first consider Antithetic Variates. Using Antithetic Variates, Boyle (1976), decreases the 95% confidence limits for a 20-period contingent claim from ± 0.958 to ± 0.574 .

Antithetic Variates induce narrower confidence intervals and therefore higher efficiency and precision without disturbing the expectation i.e. the first moment. Antithetic Variates achieve this by using complimentary pairs of random variates. More precisely Antithetic Variates induce negative correlation between the pairs of random variates. The mathematical basis of Antithetic Variates is as follows. Consider a sequence of random variables underlying, for example, the $e_s(t)$ process in Eqn. 4.8, where we have $(e_{s1}(t_1), e_{s2}(t_1)), (e_{s1}(t_2), e_{s2}(t_2)) \dots \dots (e_{s1}(t_n), e_{s2}(t_n))$, and where $e_{sk}(t_i)$ is the i^{th} pair of observations and k^{th} occurrence - for $i = 1 \dots n$ and $k = 1$ to 2. We can generate the first observation in a pair, $e_{s1}(t_1)$, by using a random variate $\varepsilon_1(t_1)$ and generate the second observation in the pair, $e_{s2}(t_1)$, by using a random variate $\varepsilon_2(t_1)$ which is simply equal to $-\varepsilon_1(t_1)$ and where $\varepsilon_1(t_i)$ approximates $N(0, 1)$. Now because $\varepsilon_1(t_i)$

approximates $N(0, 1)$, $\varepsilon_2(t_i)$ necessarily also approximates $N(0, 1)$ and provides a basis for generating $e_{s2}(t_i)$. We therefore have it that if $E(\varepsilon_1(t_i)) = \mu$ then $E(\varepsilon_2(t_i)) = \mu$ for $i = 1 \dots n$. Each pair of observations is however independent such that $(\varepsilon_1(t_i), \varepsilon_2(t_i)) \neq (\varepsilon_1(t_{i+1}), \varepsilon_2(t_{i+1}))$. We however use the mid-point of each pairs of observations such that $\varepsilon(t_i) = (\varepsilon_1(t_i) + \varepsilon_2(t_i))/2$. Here $E(\varepsilon(t_i)) = \bar{\varepsilon}(t_i)$. Now

$$Var(\bar{\varepsilon}(t_i)) = \frac{Var(\varepsilon_1(t_i)) + Var(\varepsilon_2(t_i)) + 2Cov(\varepsilon_1(t_i), \varepsilon_2(t_i))}{4n} \quad (4.17)$$

for $i \dots n$. The pair replication generates for a small $\varepsilon_1(t_i)$ a large $\varepsilon_2(t_i)$, and a large $\varepsilon_1(t_i)$ generates a small $\varepsilon_2(t_i)$. As a result $Cov(\varepsilon_1(t_i), \varepsilon_2(t_i))$ is necessarily less than zero. This negative correlation reduces $Var(\bar{\varepsilon}(t_i))$ and thereby improves the efficiency of the estimates. See Barraquand (1995), Boyle et al. (1997) and Averill (2007) for expositions of Antithetic Variates.

Antithetic variates can also be applied where a sample is drawn from $U(0, 1)$. To illustrate consider a sequence of random variables $(e_{s1}(t_1), e_{s2}(t_1)), (e_{s1}(t_2), e_{s2}(t_2)) \dots \dots (e_{s1}(t_n), e_{s2}(t_n))$ where $e_{sk}(t_i)$ is the i^{th} pair of observations and k^{th} occurrence - for $i = 1 \dots n$ and $k = 1$ to 2 . We can generate the first observation in a pair, $e_{s1}(t_1)$, by using a random variate $U_1(t_1)$ and generate the second observation in the pair, $e_{s2}(t_1)$, by using a random variate $U_2(t_1) = (1 - U_1(t_1))$ where $U_1(t_i)$ approximates $U(0, 1)$. Now because $U_1(t_i)$ approximates $U(0, 1)$, $U_2(t_i)$ also necessarily approximates $U(0, 1)$ and provides a basis for generating $e_{s2}(t_1)$. We therefore have it that if $E(U_1(t_i)) = \mu$ then $E(U_2(t_i)) = \mu$ for $i = 1 \dots n$. Each pair of observations is however independent such that $(U_1(t_i), U_2(t_i)) \neq (U_1(t_{i+1}), U_2(t_{i+1}))$. We use the mid-point of each pairs of observations such that $U(t_i) = (U_1(t_i) + U_2(t_i))/2$. Here $E(U(t_i)) = \bar{U}(t_i)$. Now

$$Var(\bar{U}(t_i)) = \frac{Var(U_1(t_i)) + Var(U_2(t_i)) + 2Cov(U_1(t_i), U_2(t_i))}{4n} \quad (4.18)$$

for $i \dots n$. The pair replication generates for a small $U_1(t_i)$, a large $U_2(t_i)$ and vice versa.. As a result $Cov(U_1(t_i), U_2(t_i))$ is necessarily less than zero. This negative correlation reduces $Var(\bar{U}(t_i))$ and thereby improves the efficiency of the estimates.

4.5.3 Control Variates

Control Variates are a further technique for improving the efficiency of Monte Carlo simulation. Using control variates, Boyle (1977), decreases the 95% confidence limits of estimates of option values from ± 0.958 to ± 0.026 for a 20-period contingent claim. The Control Variate method uses knowledge about the correlation between random variables in a simulation to modulate realizations of runs and thereby improve the confidence limits of the estimates. To illustrate, consider the random variable $S_a(t)^*$ introduced in Section 4.4.2. We introduce a second random variable $R(t)$ which is correlated to $S_a(t)^*$, and has a theoretical average $\hat{R}(t)$. A simulated run of n observations will have an average,

$$\bar{R}(t) = \frac{1}{n} \sum_{t=1}^n R(t). \quad (4.19)$$

Now the Control Variate Method uses knowledge of the correlation between $S_a(t)^*$ and $R(t)$, and also knowledge of the deviation of $\bar{R}(t)$ from $\hat{R}(t)$ to provide adjusted estimates as follows

$$\widetilde{S}_a(t)^* = S_a(t)^* - \alpha(\bar{R}(t) - \hat{R}(t)) \quad (4.20)$$

where $\widetilde{S}_a(t)^*$ is the adjusted estimator, $S_a(t)^*$ is the unadjusted estimator and α is a constant. The variance of the adjusted estimator is⁷

⁷The variance of the two processes are in the interval $[s, t]$ and can be more concisely expressed as $Var(S_a(t)^* | F_s)$ and $Var(\bar{R}(t) | F_s)$. However for clarity of exposition we use the abbreviated terms $Var(S_a(t)^*)$ and $Var(\bar{R}(t))$.

$$Var(\widetilde{S}_a(t)^*) = Var(S_a(t)^*) + \alpha^2 Var(\overline{R}(t)) - 2\alpha Cov(S_a(t)^*, \overline{R}(t))$$

$$= Var(S_a(t)^*) + \alpha^2 Var(\overline{R}(t)) - 2\alpha \rho(S_a(t)^*, \overline{R}(t)) \sqrt{Var(S_a(t)^*) Var(\overline{R}(t))} \quad (4.21)$$

The value of α is found by determining a value that minimizes the volatility of $\widetilde{S}_a(t)^*$. This is found by differentiating the right-hand side of Eqn. 4.21 with respect to α and setting this to zero – this gives⁸

$$\begin{aligned} \alpha &= \frac{Cov(S_a(t)^*, \overline{R}(t))}{Var(\overline{R}(t))} \\ &= \rho(S_a(t)^*, \overline{R}(t)) \frac{\sqrt{Var(S_a(t)^*)}}{\sqrt{Var(\overline{R}(t))}} \end{aligned} \quad (4.22)$$

We can see that the variance of $\widetilde{S}_a(t)^*$ is smaller than the variance of $S_a(t)^*$ if for a positive value of α the following holds

$$\alpha < 2\rho(S_a(t)^*, \overline{R}(t)) \frac{\sqrt{Var(S_a(t)^*)}}{\sqrt{Var(\overline{R}(t))}} \quad (4.23)$$

Similarly the variance of $\widetilde{S}_a(t)^*$ is smaller than the variance of $S_a(t)^*$ if for a negative value of α the following holds

$$\alpha > 2\rho(S_a(t)^*, \overline{R}(t)) \frac{\sqrt{Var(S_a(t)^*)}}{\sqrt{Var(\overline{R}(t))}} \quad (4.24)$$

Therefore if $S_a(t)^*$ and $\overline{R}(t)$ are positively correlated a variance reduction will be realized if Eqn. 4.23 above holds. Here α takes a positive value. If $S_a(t)^*$

⁸Note that $Corr(S_a(t)^*, \overline{R}(t)) = \frac{Cov(S_a(t)^*, \overline{R}(t))}{\sqrt{Var(S_a(t)^*) Var(\overline{R}(t))}}$

is above its expectation, the positive quantity $\alpha(\bar{R}(t) - \hat{R}(t))$ reduces $S_a(t)^*$. If on the other hand $S_a(t)^*$ and $\bar{R}(t)$ are negatively correlated a variance reduction is realized if Eqn. 4.24 above holds. Here α takes a negative value. If $S_a(t)^*$ is above its expectation, the negative $\alpha(\bar{R}(t) - \hat{R}(t))$ increases $S_a(t)^*$. See Boyle et al. 1997, Hull and White 1988 and Kemna and Vorst (1990) for applications of Control Variates. While presenting a useful method for improving the efficiency of the Monte Carlo method, this study does not use control variates because there does not exist a variable that is known to be correlated to the $S_a(t)^*$ process, and whose theoretical value can be determined.

4.5.4 Other Variance Reduction Techniques

The other VRTs discussed in the literature in the context of pricing of derivative securities include moment matching, stratified sampling and importance sampling. This section provides a broad overview of these techniques and discusses the reasons why these have not been used in this study. Moment matching is discussed in the literature as a method for improving the efficiency of MC simulation. See for example Boyle et al. (1997). To illustrate this method, consider Eqn. 4.8. Now the sample moments of $\varepsilon(t)$ for $(t = 1, \dots, n)$ may not necessarily exactly match the moments of a standard normal distribution. In such circumstances, moment matching can be used to correct undesired deviations of the moments of $\varepsilon(t)$. With respect to the first moment of $\varepsilon(t)$, moment matching is applied as follows

$$\tilde{\varepsilon}(t) = \varepsilon(t) - \bar{\varepsilon}(t) \tag{4.25}$$

where

$$\bar{\varepsilon}(t) = \sum_{t=1}^n \frac{\varepsilon(t)}{n} \tag{4.26}$$

where $\tilde{\varepsilon}(t)$ is the adjusted estimate and $\varepsilon(t)$ is the unadjusted estimate for

$t = 1, \dots, n$. Moment matching can be extended to correct the first two moments of $\varepsilon(t)$. For example, where the mean and variance of $\varepsilon(t)$ are different from those of the underlying distribution, moment matching can be used as follows

$$\tilde{\varepsilon}(t) = (\varepsilon(t) - \bar{\varepsilon}(t)) \frac{\sigma_a}{\sigma_b} + a \quad (4.27)$$

where a and σ_a is the first moment and the standard deviation of the underlying population, respectively and σ_b is the standard deviation of the $\varepsilon(t)$. See Boyle et al. 1997. Using the method of moments, Eqn. 4.8 takes the following form

$$e_s(t) = \sigma_{as} \sqrt{\frac{(1 - e^{-2\gamma_{as}(t-s)})}{2\gamma_{as}}} \tilde{\varepsilon}(t) \quad (4.28)$$

Similarly, using the method of moments, the noise associated with Eqn. 4.14 can be restated as follows

$$e_\rho(t) | F_s = \sigma_{a\rho} \sqrt{(t-s)} \tilde{\varepsilon}(t) \quad (4.29)$$

The SDE in Eqn. 4.8 and Eqn. 4.14 assume a random process underlined by a standard normal distribution. This study is based on a large sample size – a sample size of 10,000 is used. This mitigates the risk, inherent in small samples, of the moments of the random variates being biased. For this reason moment matching is not used.

Stratified sampling is also discussed in the literature as a method for increasing the efficiency of stochastic simulation as a numerical method. To illustrate this example consider again Eqn. 4.8. Now if we consider a run of say 100 intervals, the distribution of the $U(t)$ (for say, $t = 1, \dots, 100$) may not exactly reflect a uniform distribution as some segments of the area of integration will be under-represented. Stratified sampling overcomes this drawback by spreading the sample evenly throughout the area of integration. See Boyle et al. (1997). Taking a sample run with 100 intervals, the simulation inputs would be as

follows

$$X(t) = F^{-1}((t + U(t) - 1)/100) \quad (4.30)$$

Here $t = 1, \dots, 100$ and where F^{-1} is the inverse of the cumulative normal distribution, $U(t)$ is a random variate from $U(0, 1)$. This method therefore spreads the observations fairly uniformly throughout the domain of integration. In essence one observation lies in between the $(t - 1)^{th}$ and t^{th} percentile. See Boyle et al. (1997). We do not use stratified sampling because this study uses a large sample.

Importance sampling is a further approach to increasing the efficiency of stochastic simulation. Importance sampling improves efficiency by narrowing the domain of integration to the specific area of interest. To illustrate consider Eqn. 4.1 where we have that the function $h(u)$ is integrated over the domain A (see George and Casella (2004), pp 92). If we have, for example, that the extremes of this domain are not of interest but rather another domain $B \in A$, then the following equality can be used as a basis of estimation

$$\bar{y}^* = \int_B \frac{h(u)f(u)g(u)}{g(u)}d(u) \quad (4.31)$$

where $g(u)$ represents the *pdf* of U in B .

4.5.5 Low Discrepancy Sequences

The $U(0, 1)$ distribution will commonly be used as a basis for generating, through appropriate transformations, the distributions that are used in stochastic simulation, for example $N(0, 1)$. In the discussion so far the $U(0, 1)$ is represented by pseudo-random numbers generated in the interval $[0, 1]$. Pseudo-random numbers may however cluster and therefore not uniformly cover the domain of integration. Low-discrepancy sequences also referred to as quasi-random numbers address this shortcoming. In doing so these sequences enhance convergence. Four low-discrepancy sequences are commonly used in the

literature - these include Halton (1960), Sobol (1967), Faure (1982) and Niederreiter(1988) sequences. Galanti and Jung (1997), among others, discuss the mechanics for generating these sequences.

Galanti and Jung (1997) study the efficiency of low discrepancy sequences in the context of pricing European call options. The study separately considers 1, 10 and 250 time periods. For each time period the number of simulations is gradually varied from 1,000 to 200,000. The study finds that with one time interval the low-discrepancy sequences outperform the pseudo-random numbers. The study further finds that with 10 time periods, the low discrepancy sequences decidedly outperform pseudo-random numbers after 10,000 simulations. For 250 time intervals, the study finds that only the Sobol sequences outperforms pseudo-random numbers after 10,000 simulations. For this time interval and at 15,000 simulations, the respective errors of the pseudo-random numbers, Halton, Faure and Sobol sequences are 0.90%, 13.68%, 3.25% and 0.34%, respectively. The study concludes that for high-dimensional integrals, the Sobol sequence exhibits better results than either Faure or Halton sequences. More generally, for large sample sizes, there is little distinction between the efficiency of pseudorandom numbers combined with antithetic variates and either Sobol or Faure sequences. Overall, Galanti and Jung conclude that the efficiency of low discrepancy sequences relative to pseudo-random numbers very much depends on the dimensions of a simulation and the complexity of the underlying integrals.

Pastov and Traub (1995) evaluate the relative efficiency of pseudo-random and quasi-random numbers. The study is based on mortgage backed securities and evaluates integrals with more than 360 dimensions. They find that Sobol's sequences are more efficient than Halton's sequences. They also find that low-discrepancy sequences outperform pseudo-random numbers. In contrast Bratley et al. (1992) find that pseudo-random numbers outperform low-discrepancy sequences for dimensions greater than 12. Boyle et al. (1997) evaluate the relative efficiency of pseudo-random numbers and low discrepancy sequences. Using

50,000 dimensions they find that low-discrepancy sequences outperform pseudo-random numbers, and that Sobol's sequence outperform Faure's sequence. For higher dimensions pseudo-random numbers outperform Faure sequences but Sobol's sequences remain superior to pseudo-random numbers. Boyle et al. (1997) find that while Faure and Sobol sequences outperform pseudo-random numbers for dimensions up to 200,000, between the two low discrepancy sequences, Sobol's sequences were generally outperformed for dimensions in the middle two quartiles.

Taken together the above results suggest that Sobol sequences are generally more efficient than either Halton's or Faure's sequences. However the evidence is mixed on the relative superiority of low discrepancy sequences over pseudo-random numbers for computations with high dimensions. On one hand Bratley et al. (1992) find the pseudo-random numbers outperform low discrepancy sequences for computations with high dimensions, on the other, the studies by Pastor and Traub (1995) and Boyle et al. (1997) have results that find otherwise. What is however instructive is the finding by Galanti and Jung (1997) that combining pseudo-random numbers with Antithetic Variates result in around about the same efficiency as low discrepancy sequences. Based on these findings, low discrepancy sequences are not used in this study.

4.6 Closed-Form Analytical Solutions

Closed-form analytical solutions can be used to value contingent claims where the value of the underlying asset is driven by a small set of sources of uncertainty, defined by Gaussian processes. Black and Scholes (1973) present a closed-form analytical solution to value a contingent claim where the value of the underlying security is defined by a Geometric Brownian Motion. Stulz (1982) presents a closed-form analytical solution for pricing an option whose underlying value depends on a maximum of two sources of uncertainty. In this study, the development of closed-form analytical solutions draws on the

Gaussian distributions that underpin the processes that define the evolution of the downstream value of exchange lines. In the case of the analogue platform we know, as is subsequently shown in Eqn. 5.58, that downstream value of an activated line, under risk-neutral expectations, can be represented as follows

$$E^Q[S_a(t)^* | F_s] = (S_a(s)^* - \alpha_{as}^*(s))e^{-\gamma_{as}(t-s)} + \alpha_{as}^*(t) \quad (4.32)$$

where

$$\alpha_{as}^*(t) = \beta_s + \xi_s(t) + \eta_s \sin(\omega_s t + v_s) - \frac{\lambda_1 \sigma_{as}}{\gamma_{as}} \quad (4.33)$$

Here $S_a(t)^*$ represents the evolution of the log of net average downstream value of an exchange line, σ_{as} the volatility of the SDE describing the evolution of $S_a(t)^*$, $\alpha_{as}^*(t)$ the risk-neutral level around which $S_a(t)^*$ oscillates. The parameters of the trigonometric function, β_s , ξ_s , η_s , ω_s and v_s , are constants. Here λ_1 is the price of market risk. Now the variance associated with Eqn. 4.32 is defined as follows

$$Var^Q[S_a(t)^* | F_s] = \frac{\sigma_{as}^2}{2\gamma_{as}}(1 - e^{-2\gamma_{as}(t-s)}) \quad (4.34)$$

As will be subsequently shown in Eqn. 5.35, the evolution of exchange line activation for the analogue platform can be represented as follows

$$E[\rho_a(t) | F_s] = \rho_a(s) \exp \left[\left(\phi_{a\rho} - \frac{1}{2} \sigma_{a\rho}^2 \right) (t - s) \right] \quad (4.35)$$

here $\rho_a(t)$ represents the intensity of exchange line activation and $\phi_{a\rho}$ the drift of activation. For ease of exposition letting $\mu_{as}(t) = E^Q[S_a(t)^* | F_s]$, $\sigma_{af} = Var^Q[S_a(t)^* | F_s]$ and $u = \ln F(S_a(t); t, t)$, we have that downstream value on the risk-neutral process, in an activated state, is

$$V(S_a(t); s, t) = \int_{-\infty}^{+\infty} (F(S_a(t); t, t) - K_a) \frac{1}{\sigma_{af} \sqrt{2\pi}} \exp \left\{ -\frac{1}{2} \left[\frac{u - \mu_{as}(t)}{\sigma_{af}} \right]^2 \right\} du \quad (4.36)$$

where K_a the price of access to the Subscriber Network. Knowing that a rational access seeker will align entry and exit and negotiate contractual terms such that $F(S_a(t); t, t) > K_a$, the risk-neutral value accruing to an access seeker is therefore

$$\begin{aligned} E[(F(S_a(t); t, t) - K_a), 0]^+ &= \\ & \int_{\ln K_a}^{+\infty} (F(S_a(t); t, t) - K_a) \frac{1}{\sigma_{af} \sqrt{2\pi}} \exp \left\{ -\frac{1}{2} \left[\frac{u - \mu_{as}(t)}{\sigma_{af}} \right]^2 \right\} du \\ &= \int_{\ln K_a}^{+\infty} F(S_a(t); t, t) \frac{1}{\sigma_{af} \sqrt{2\pi}} \exp \left\{ -\frac{1}{2} \left[\frac{u - \mu_{as}(t)}{\sigma_{af}} \right]^2 \right\} du - \\ & \quad \int_{\ln K_a}^{\infty} K_a \frac{1}{\sigma_{af} \sqrt{2\pi}} \exp \left\{ -\frac{1}{2} \left[\frac{u - \mu_{as}(t)}{\sigma_{af}} \right]^2 \right\} du \end{aligned} \quad (4.37)$$

The relationships in Eqn. 4.35 and Eqn. 4.37 can be used as the basis of a closed-form analytical solution. The closed-form solutions present a basis for generalizing the results. Similar arguments can be furthered for the ADSL platform.

4.7 Summary

At a first level of enquiry, case study research is used to define the dynamics that describe downstream value in telecommunications capacity platforms. This understanding is used to develop models that describe the evolution of such value and subsequently test the symmetry of cost-based access prices from the standpoint of option pricing theory. The data used in this study is based

on UK evidence from the analogue and ASDL capacity access platforms. On the analytical methods, this study uses a two-prong approach – a numerical method, Monte Carlo simulation and closed-form analytical solutions. Monte Carlo simulation is used because of its versatility in computing high-dimensional integrals and valuing complex derivatives defined by multi-dimensional stochastic processes. The closed-form analytical solutions first, provide a basis for checking the results from the numerical methods. Second, these solutions generalize the results and provide an option-theoretic framework for pricing access where third parties have the leverage of adapting to downstream stochastic value.

Chapter 5

ANALOGUE CAPACITY ACCESS: CONTINGENT CLAIM ANALYSIS

5.1 Introduction

This chapter develops a framework for valuing the flexibility of adapting to downstream value, and tests the neutrality of FL-LRIC¹ as an approach for pricing capacity access, based on evidence from the analogue platform. This evidence is from the residential analogue capacity market in the UK and covers the period September 1999 to July 2007. Option pricing theory is used as a theoretical framework. This pricing theory is used because of its capacity to conceptualize and quantify the value of flexibility. A numerical method, Monte Carlo simulation, is used because of its capacity to value complex derivatives defined by multi-dimensional stochastic processes. In using a numerical method, an intensity-based approach is used to value contingent claims on the process generating value. The price of market risk and the price of the risk of default are used as the handles that define the martingale equivalents of the process that generates value. Maximum Likelihood Estimation is used to calibrate the stochastic differential equations describing downstream value and the value of the underlying contingent claims are estimated using risk-neutral valuation principles.

The analysis in this chapter assumes the typical model in a liberalized network where third parties (access seekers) have wholesale rights to the Subscriber Access Network and therefore downstream rights to provide retail services to end users. Under this model, third parties also have wholesale access rights to the Conveyance Network. A third party is therefore able to provide end-to-end

¹Forward-looking, long-run incremental costs.

connectivity to its subscribers by renting an incumbent's infrastructure. Further, under this model the price of third-party access to the Access Network is regulated being that this part of the infrastructure is considered as a bottleneck facility. A descriptive overview of the analogue access network is presented in Section 5.2. The model describing downstream value and its constituent parts are discussed in Sections 5.3 to 5.5. Section 5.6 presents a framework for calibrating the model. Section 5.7 provides a framework for valuing a contingent claim on the process defining downstream value. Closed-form analytical solutions are developed in Chapter 7. The results and discussion are covered in Chapter 8.

5.2 Network Topology

5.2.1 Subscriber Access Network

The analogue access infrastructure comprises two layers² – the Subscriber Access Network³ (hereinafter referred to as the Access Network) and the Conveyance Network.⁴ The Access Network extends from a subscriber's premise to a telephone exchange. The first layer of the analogue access network, the Access Network, extends from a subscriber's premises to the MDF of an exchange. Each subscriber exchange line is a dedicated twisted copper wire pair extending from the Network Termination Equipment (NTE) at subscriber's premises to the MDF of a telephone exchange. Each NTE will have one or more exchange lines and each line runs from the NTE to the exchange in a hierarchical structure. A final drop cable, which may either be overhead or underground, joins

²The source of data for this descriptive overview includes Ofcom (1997) - Network Charges from 1997; Ofcom (2005a) - Local Loop Unbundling: Setting the Fully Unbundled Rental Charge Ceiling and Minor Amendment to SMP Conditions FA6 and FB6; Ofcom (2005b) - Review of BT's Network Charge Control; Ofcom (2005c) - Valuing Copper Access; Ofcom (2005d) - Wholesale Line Rental: Reviewing and Setting Charge Ceilings for WLR Services; BT's Regulatory Accounts (various); and Analysys (2005) - Cost of the BT UK Local Loop Network.

³Also commonly referred to as the Local Loop Access Network.

⁴The Conveyance Network is the upstream infrastructure connecting exchanges.

the NTE to the first concentration point, a Distribution Point (DP). Typically there will be two concentration points between the NTE and the exchange. The first of these are DPs which concentrate between 20-30 active wire pairs. The second class of concentration points are the Primary Concentration Points (PCPs) which concentrate between 500-600 active wire pairs.

The DPs and PCPs, and the PCPs and MDF are linked by cables buried in ducts. The PCPs lead to the MDF at the exchange. An MDF together with its associated PCPs, DPs and NTEs represent an access area. The part of the access layer that extends from the MDF in an exchange to and including the PCP is referred to as the E-side and the part of the layer that is immediately after the PCP up to and including the DP is referred to as the D-Side. The MDF, PCP, DP and NTE will typically be above ground structures and the D-side and E-side cabling will usually be underground structures. The drop wire could either be above or below ground-level - see Figure 5.1.

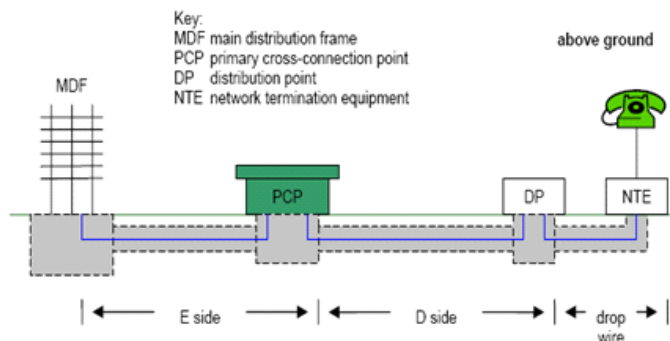

Source: Ofcom (2005)

Figure 5.1: Analogue - Network Topology

The regulated wholesale price of access to Access Network is a geographically averaged unit cost of an exchange line. The unit costs in the access layer

are mainly driven by demographics, in particular, population density. This density drives the dimensions of the network. These dimensions aim to optimize network efficiency and define, for a service area, the number of NTEs per DP, number of DPs per PCP and PCPs per route. Further the unit costs will depend on the network structure, for example, the type of soil, type of duct, type of cable and type of cabinets. Capacity buffers, through over-provisioning, also impacts unit costs. The Access Network is usually over-provisioned to provide for the spare capacity required to guarantee network availability and cater for demand growth. The unit cost of a node (MDF, PCP and DP) is primarily a function of capacity, and the cost of the link between the nodes (cables and ducts) is a function of capacity and length.

5.2.2 Conveyance Network: Switching Layer

The conveyance network consists of switching and transport layers.⁵ Typically a local-exchange will serve an area referred to as a local exchange area where each subscriber will have a dedicated line to the exchange. More than one exchange may be required to serve a local area where there are a large number of subscribers and where one exchange is not efficient. In such a multi-exchange area, subscribers are assigned to a specific exchange but connectivity between the exchanges is made possible through junctions which join the exchanges. This allows any-to-any connectivity - see Figure 5.2.

In addition to being linked to one another, the local exchanges will be connected to a tandem switch. A tandem switch, commonly referred to as a trunk or transit exchange, generally serves a local area. A tandem switch will be connected to a tandem switch in other exchange areas to provide any-to-any connectivity between local exchange areas. In addition to being connected to other tandem switches, a tandem switch will be connected to an international switch, an international gateway, which connects the network in one country with the networks in other countries, thereby providing any-to-any connectivity

⁵The MDF is the demarcation between the Access and Conveyance Networks.

between countries. In some cases however the switching nodes lowest in the hierarchy will be a Remote Concentrator Unit (RCU) which is a small digital exchange. The RCU will be located away from the local exchange, have the capacity to carry out a number of switching functions and is driven by the processors in the parent local exchange. The switching layer is therefore made up of the nodes in the network i.e. RCUs, local exchanges, tandem switches and national switches. The components of a remote concentrator will be similar to those of a local exchange – the key components being the Subscriber Line Termination Unit, switchboard, processor and Digital Line Termination Units. Except for the SLTU, the tandem switch will have similar components to the RCU or local exchange.

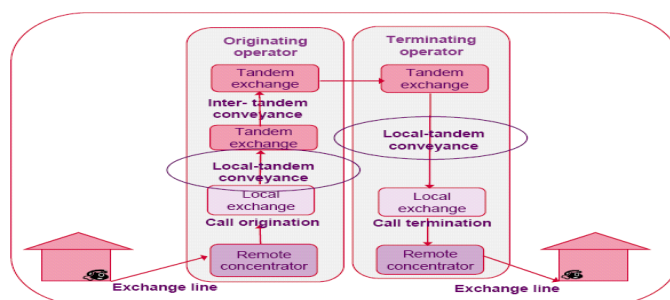

Source: Ofcom (2005)

Figure 5.2: Conveyance Infrastructure

The capacity of the various components of the switching nodes are dimensioned to cater for busy hour traffic and are either functions of busy hour call attempts or busy hour call durations. For example, the capacity and cost of a processor is driven by the number of busy hour call attempts. The processor runs programmes controlling the switch and also maintains the network

database, which has subscriber and switching information. The switch block switches calls and its capacity and cost is driven by traffic intensity i.e. busy hour call attempts and their duration. Other costs attributable to switching elements are site costs (land and buildings) and Signalling Transfer Points which facilitate communication between the processors of different exchanges. The DLTU provides the interface to the switch and their cost is driven by the number of lines to other exchanges.

While the capacity of the different elements of the switching apparatus will be dimensioned primarily with reference to either the number of busy hour call attempts and/or busy hour call durations, this capacity is usually over-provisioned to provide for the spare capacity required to guarantee network availability and cater for growth in demand growth. The access price for a switching element is the geographical averaged unit cost per unit of time. This is therefore based on aggregate costs of an element during a regulatory lag divided by the expected demand in minutes.

5.2.3 Conveyance Network: Transport Layer

The transport layer comprises the physical links connecting the nodes in the Conveyance Network. The transport layer therefore includes the links between: a RCU and a local switch; two adjacent local switches; a local switch and a tandem switch; and two tandem switches. These links include transmission infrastructure and electronics – the infrastructure comprising ducts and cables and the electronics comprising multiplexing, line termination equipment and digital cross-connects.

The RCUs in a local area are connected to each other in a “ring” structure by an SDH ring referred to as the RCU ring. The RCU rings will have both way capabilities with the size of each ring corresponding to the dimensioned capacity. Each RCU is connected to an RCU ring by an add drop multiplexers (ADM) and each ring is connected to the local exchange (gateway node) by a multiplexer. The multiplexing equipment at the gateway node corresponds to

the capacity of the RCU ring.

The number of RCUs per ring and the capacity of each ring is primarily a function of subscriber density. Transmission equipment will have regenerators after threshold intervals to boost signal transmission. The local switches are connected by SDH rings, referred to as LS rings. The number and capacity of LS rings will depend on subscriber density and traffic intensity. As with the RCU rings, each local switch is connected to the LS ring by an ADM and each LS ring is connected to a gateway tandem by a multiplexer. As with RCU rings, transmission along the LS rings is boosted by regenerators. Unlike the connections between RCUs and between local switches, connections between tandem switches take the form of a partial mesh allowing point-to-point connectivity. Such connectivity is made possible by digital cross-connects. In cases where there may not be a direct path between two tandem switches, such point-to-point connectivity is made through digital cross-connects.

The RCU and LS rings will usually run underground as part of underground plant. The plant, also referred to as infrastructure, comprises primarily of ducts and cables. A duct will usually be made of a trench and a duct route. The cost of the underground plant will not only be driven by capacity and length of the plant but also differences in geo-types, for example, terrain types. The cost of a duct will vary depending on whether it is a metropolitan area, urban or rural area as these differences affect the cost of digging and reconstructing surfaces.

The dimensions of the transport layers are based on busy-hour billed minutes. This is adjusted for holding times, allowance for growth, leased lines and an allowance to provide for network resilience. The regulated access price for a transport element is the geographical averaged unit cost. This is therefore based on the aggregate costs of an element during a regulatory lag divided by the expected demand in minutes.

5.3 Model Specification

5.3.1 Downstream Value

We focus on the typical model in a liberalized network where third parties (access seekers) have wholesale rights to the Access Network and therefore downstream rights to provide retail services to end users. Under this model, third parties also have wholesale access rights to the Conveyance Network. A third-party is therefore able to provide end-to-end connectivity to its subscribers by renting an incumbent's infrastructure.⁶ Further, under this model the price of third-party access to the Access Network is regulated being that this part of the infrastructure is considered as a bottleneck facility. Now downstream value to an access seeker depends on the regulated price of access to the Access Network, revenue from an exchange line (which has a fixed and variable component), cost of conveyance through the meshed core network and the stochastic state of a line. In the ideal situation, the key statistic required for contingent claim analysis is that which captures the evolution of average downstream value of an exchange line. This is however not available as a single statistic from the data in the public domain. What is however available is data that captures the constituent parts of downstream value (average traffic per exchange line across customers, revenue per unit of traffic, conveyance charges per unit of traffic etc). The analysis in this chapter is built on this secondary evidence. Based on this evidence, if we consider a representative portfolio of analogue exchange lines, downstream value through time, based on the premise of average throughput, in the constrained case,⁷ is represented as follows

⁶While this study is based on the model where a third-party purchases end-to-end connectivity, it is recognized that an access seeker may opt to purchase only a subset of the network elements required to provide end-to-end connectivity, and supplement these with its own elements.

⁷Where an access seeker does not have the flexibility to adapt to downstream stochastic processes.

$$Z_{ai}(t) = \begin{cases} X_a(t)(Y_a(t) - U_a(t)) + V_a(t) - M_a(t) - K_a(t) & \text{if } L_{ai}(t) = 1 \\ -\nu M_a(t) - K_a(t) & \text{if } L_{ai}(t) = 0 \end{cases} \quad (5.1)$$

The subscript a distinguishes the analogue platform from the ADSL platform studied in Chapter 6. Here $Z_{ai}(t)$ represents the downstream value of the i^{th} exchange line in a representative portfolio.⁸ $X_a(t)$ represents the variable, average traffic per exchange line per unit time;⁹ $Y_a(t)$ represents average tariffs per unit of traffic; $U_a(t)$, the average price of conveyance per unit of traffic; $V_a(t)$, the regulated retail rental per unit of time; $M_a(t)$ other costs; and $L_{ai}(t)$ the state of an exchange line.¹⁰ Here ν represents the proportion of value that cannot be re-assigned. Now $X_a(t)$ and $L_{ai}(t)$ are stochastic while $Y_a(t)$, $U_a(t)$, $V_a(t)$, $M_a(t)$ and $K_a(t)$ are relatively deterministic during a regulatory lag. Now the dynamics through space, for a given point in time, can be represented as follows

$$Z_{at}(i) = \begin{cases} X_a(t)(Y_a(t) - U_a(t)) + V_a(t) - M_a(t) - K_a(t) & \text{if } P_{at}(i) = 1 \\ -\nu M_a(t) - K_a(t) & \text{if } P_{at}(i) = 0 \end{cases} \quad (5.2)$$

for $i = 1, \dots, n$, where $P_{at}(i)$ defines the state of the i^{th} of element of a representative portfolio of exchange lines at time t in the analogue platform. Now $P_{at}(i) = 1$ with a probability $\rho_a(t)$ or 0 with a probability $1 - \rho_a(t)$. An access seeker has the right to the downstream value described by $S_{ai}(t)$ subject

⁸For $i = 1, \dots, n$

⁹This represents an average across customers at each time interval and is therefore the expected throughput per individual exchange line in a representative portfolio at time t . This study focuses on the mainstream market segment where traffic comprises of local, national and international calls, and calls to mobiles.

¹⁰For $i = 1, \dots, n$

to a price,¹¹ $K_a(t)$, the regulated price of access to the Access Network. We discuss the algorithms that capture the $L_{ai}(t)$ and $\rho_a(t)$ processes in Section 5.5.

In a liberalized capacity access framework, the regulated price of access to the Access Network constitutes the substantive equivalent of a strike price, from the standpoint of contingent claim analysis, for four main reasons. First, the price allows an access seeker to participate in the downstream market. Second, the access price is fixed for a specified period (regulatory lag). Third, the downstream market is characterized by uncertainty with both a potential upside and downside. Fourth, the right to participate in the downstream market does not have a corresponding obligation. Now conveyance charges have a substantive form that is different from the charges to the Access Network,¹² from the standpoint of contingent claim analysis because these charges are only incurred by an access seeker if there is downstream activation. The $X_a(t)$ and $Y_a(t)$ processes are considered in greater detail in the next section.

5.3.2 Traffic and Tariffs

$X_a(t)^*$ is defined based on observations from September 1999 to July 2007.¹³ It is observed that the evolution of this process exhibits mean-reversion with seasonal variation - see data in Table E.1 in Appendix E.¹⁴ Accordingly we describe the evolution of $X_a(t)^*$ as a trigonometric function. An expression representing this evolution is as follows

$$dX_a(t)^* = \gamma_{ax}(\alpha_{ax}(t) - X_a(t)^*)dt + \sigma_{ax}dW(t)^{ax} \quad (5.3)$$

Here $X_a(t)^*$ is defined on a probability space $(\Omega, \mathcal{A}, \mathbb{P})$. The information set is captured by $\mathbb{F} = \{F_t : t \geq 0\}$. Now $X_a(t)^*$ is F_t -measurable and is

$$S_{ai}(t) = \begin{cases} X_a(t)(Y_a(t) - U_a(t)) + V_a(t) - M_a(t) & \text{if } L_{ai}(t) = 1 \\ -\nu M_a(t) & \text{if } L_{ai}(t) = 0 \end{cases}$$

¹²Where end-to-end connectivity is purchased.

¹³Here $X_a(t)^* = \ln X_a(t)$.

¹⁴The database used for this study contains the traffic history from only September 1999.

adapted to the same filtration. The postscript/subscript a distinguishes the analogue platform from the ADSL platform studied in Chapter 6 and the postscript/subscript x distinguishes the parameters of $X_a(t)^*$ from those of other processes that will be subsequently discussed in this chapter. Now here $\alpha_{ax}(t)$ is the level around which the process fluctuates, γ_{ax} the speed of reversion to the mean and σ_{ax} the volatility of the noise term. The process has a positive drift at a rate of γ_{ax} when $\alpha_{ax}(t) > X_a(t)^*$ and a negative drift of the same rate when $\alpha_{ax}(t) < X_a(t)^*$. Now γ_{ax} and σ_{ax} are constants and $W(t)^{ax}$ is Wiener process.¹⁵ The seasonal variation exhibited by $X_a(t)^*$ is described as an ordinary trigonometric function, as follows

$$\alpha_{ax}(t) = \beta_x + \xi_x(t) + \eta_x \sin(\omega_x t + v_x) \quad (5.4)$$

where β_x , ξ_x , η_x , ω_x and v_x are constants. Here $\xi_x(t)$ captures the drift of $X_a(t)^*$ through time. Now β_x , η_x , ω_x and v_x capture the other usual parameters of a trigonometric function. The expectation with respect to Eqn. 5.3, for $t > s$, is

$$E[X_a(t)^* | F_s] = (X_a(s)^* - \alpha_{ax}(s))e^{-\gamma_{ax}(t-s)} + \alpha_{ax}(t) \quad (5.5)$$

And its variance is

$$Var[X_a(t)^* | F_s] = \frac{\sigma_{ax}^2}{2\gamma_{ax}}(1 - e^{-2\gamma_{ax}(t-s)}) \quad (5.6)$$

From Eqn. 5.5 and Eqn. 5.6, we have that the solution to Eqn. 5.3 is

$$X_a(t)^* = (X_a(s)^* - \alpha_{ax}(s))e^{-\gamma_{ax}(t-s)} + \alpha_{ax}(t) + \sigma_{ax} \sqrt{\frac{(1 - e^{-2\gamma_{ax}(t-s)})}{2\gamma_{ax}}} \varepsilon \quad (5.7)$$

¹⁵The model above assumes that γ_{ax} and σ_{ax} are constants. Evidence from data points obtained from more frequent intervals and from a longer time series may suggest otherwise. The model above should therefore be seen as a first-order model which could be developed further to accommodate any stochastic behaviour of γ_{ax} and σ_{ax} .

where ε is a random variable from a standard normal distribution. The basis of Eqn. 5.5 and Eqn. 5.6 are developed more fully in Appendix A.

The $Y(t)$ process is defined based on observations from September 1999 to December 2007. In the initial period to the third quarter of 2004, the evolution shows a transitory trend. A steady-state is observed in the ensuing period where average prices approximate a constant. The analysis in this section assumes the values in the steady state.

5.4 Access Layer and Conveyance

The FL-LRIC charge for the right of access to the Access Layer comprises two parts. The first part is charged per unit time and the second is an event-based (activation) charge. The former charge is the sum of the geographical average element cost of each of the six elements comprising the Access Layer - these include E-Side copper, D-Side copper, local exchange general frames, line test equipment, drop wire capital and PSTN NTE, and PSTN Line Card. The first part is therefore a charge for wholesale access from the NTE to the MDF. Each of these elements has a regulated access price chargeable per unit time. The second charge arises each time a wholesale connection is made. This charge is therefore driven by the intensity with which exchange lines transition from a non-activated to an activated state.¹⁶ The strike price for the right of access in an interval per exchange line per unit time can be represented as follows

$$K_a(t) = \sum_{i=1}^6 A_{ai}(t) \quad (5.8)$$

Now $A_{ai}(t)$ is defined as the regulated price of access for the i^{th} access component in the analogue access platform. We let $i = 1$ represent E-Side copper (capital and current) geographical average unit costs; $i = 2$ represent

¹⁶If we define $h(t)$ as the intensity of transitions from State 0 to State 1 and δ as the connection charge in the i^{th} access platform, then the cost of activation is simply $h(t) * \delta$. Because of its relative insignificance, this is lumped with other costs *i.e.* $M_a(t)$.

D-Side copper (capital and current) geographical average of unit costs; $i = 3$ represent local exchange general frames (capital and current) geographical average unit costs; $i = 4$ represent line test equipment (capital and current) geographical average of unit costs; $i = 5$ represent drop wire capital and PSTN NTE geographical average unit costs; and $i = 6$ represent PSTN Line Card geographical average unit costs.¹⁷

The price of conveyance is usage-driven and charged per unit of time. This charge is the sum of the geographical average cost of each of the elements required to provide a service. The elements comprising the Conveyance Layer include the local exchange processor, local-tandem link, local-tandem transmission, inter-tandem transmission link and inter-tandem transmission length. The various voice services, local, national, international and calls to mobiles use varying degrees of conveyance elements. The intensity with which an element is used is measured by its usage factor.

Now define C_{aij} as the usage factor of the i^{th} access service with respect to the j^{th} access element. Define $D_{aj}(t)$ as the unit cost of component j and $E_{ai}(t)$ as the proportion of traffic attributable to service i . The average cost of conveyance per unit of traffic, is¹⁸

$$U_a(t) = \sum_{i=1} \sum_{j=1} C_{aij}(t) * D_{aj}(t) * E_{ai}(t) \quad (5.9)$$

for $i = 1$ to 4 and $j = 1$ to 6, where $i = 1$ represents local calls, $i = 2$ represents national calls, $i = 3$ represents calls to mobiles, and $i = 4$ repre-

¹⁷The regulated access charges are published in BT's audited regulatory accounts which provide the FL-LRIC access price for the various elements of the Access Network for residential and business analogue wholesale products. This includes the unit costs of E-Side Copper, D-side Copper, local exchanges general frames, PSTN Line Test Equipment, drop wire costs and PSTN NTE and PSTN Line Cards. The data also includes of unit cost of conveyance. The data in BT's regulatory accounts is based on BT's Line Costing Study. The audited unit cost forms the basis of the regulated access charges in the UK. See Ofcom (2005d), *Wholesale Line Rental: Reviewing and Setting Charge Ceilings for WLR services*, for an aggregation of these prices.

¹⁸We obtain data on usage and unit prices from BT's regulatory accounts.

sents international calls. And $j = 1$ represents local exchange processor, $j = 2$ represents main exchange switching, $j = 3$ represents local-tandem link, $j = 4$ represents local-tandem transmission, $j = 5$ represents inter-tandem transmission link, and $j = 6$ represents inter-tandem transmission length.

We assume the usage (equipment utilisation per unit of a call) in BT's audited financial statements, for each of the four classes of calls. For local calls these are: local exchange processor (1.860), main exchange switching (0.170), local-tandem transmission link (1.787), local-tandem transmission length (24.850); inter-tandem transmission link (0.151) and inter-tandem transmission length (7.299). For national calls these are: local exchange processor (1.949), main exchange switching (1.584), local-tandem transmission link (1.768), local-tandem transmission length (27.803); inter-tandem transmission link (1.501) and inter-tandem transmission length (164.896). For calls to mobiles these are: local exchange processor (1.016), main exchange switching (1.441), local-tandem transmission link (1.272), local-tandem transmission length (16.731); inter-tandem transmission link (0.410) and inter-tandem transmission length (25.172). For international call these are: local exchange processor (1.026), main exchange switching (0.917), local-tandem transmission link (1.034), local-tandem transmission length (10.880); inter-tandem transmission link (0.345) and inter-tandem transmission length (24.034). The raw data used for the computation of $U_a(t)$ is in Table E.12 in Appendix E.

5.5 Intensity of Line Activation

5.5.1 Intensity in Equilibrium

With respect to the dynamics of activation, it is recognized that at each instant through time, there is a possibility that an activated line may be de-activated, or vice versa, for reasons which may or may not be dependent on tariffs. Activation or de-activation can therefore occur at any time during the useful life of an exchange line, and either is conceived as being triggered by an exogenous process

that is fully or partially independent of $Y_a(t)$. In the analysis that follows, we adapt an intensity-based approach to capture these dynamics. This approach finds application in circumstances where there exists a risk of default which is either partially or fully independent of the primary value of the underlying asset.

The dynamics of activation and de-activation can be explored, in equilibrium, through space/time,¹⁹ as an on-off or a renewal process. Alternatively these dynamics, through time/space,²⁰ can be explored as a Bernoulli process. While, in equilibrium, both approaches can be readily reconciled, the former approach has a strong intuitive appeal in developing the core arguments in contingent claim valuation in telecommunication networks because this approach can be reconciled more directly to the cyclical life of retail service contracts. However as will be demonstrated later in this chapter, the latter approach provides a basis for more robust analysis. Further, the data required for empirical analysis that is in the public domain only corresponds only to the second approach. Because of the aforesaid, the analysis in this chapter is initially built on the first approach to capture the essence of retail service contracts but this is subsequently transitioned to exploring the dynamics using the second approach, thereby providing a basis for empirical and more rigorous analysis.

Starting with the first approach, the dynamics of exchange line activation in a representative portfolio through time is driven by the *pdfs* of the two alternative states. We start with a consideration of the dynamics in equilibrium. Now define $f_{a0}(t)$ as the *pdf* and $F_{a0}(t)$ the *cdf* of the random variable,²¹ $L_a(k)$, time expended in State 0 by elements of a representative portfolio of residential analogue exchange lines.²² It is assumed that the realizations of $L_a(k)$ are independent and identically distributed. Now therefore $f_{a0}(t) \geq 0$ where $0 \leq$

¹⁹With space in the first dimension and time in the second.

²⁰With time in the first dimension and space in the second.

²¹The subscript/postscript a distinguishes the analogue platform from the ADSL platform studied in Chapter 6.

²²For $k = 1, \dots, n$. Here k represents an interval.

$t \leq \infty$ and

$$\int_0^{\infty} f_{a0}(t)dt = 1 \quad (5.10)$$

Further

$$F_{a0}(t) = \int_0^t f_{a0}(t)dt \quad (5.11)$$

It follows that $F_{a0}(0) = 0$, $F_{a0}(\infty) = 1$ and $f_{a0}(t) = dF_{a0}(t)/dt$. The average length of time a representative portfolio of exchange lines expend in State 0 is

$$\mu_{a0} = \int_0^{\infty} t f_{a0}(t)dt \quad (5.12)$$

Define $f_{a1}(t)$ as the *pdf* and $F_{a1}(t)$ the *cdf* of the random variable, $L'_a(k)$, time expended in State 1 by elements of a representative portfolio of exchange lines.²³ It is assumed that the realizations of $L'_a(k)$ are independent and identically distributed. Now therefore $f_{a1}(t) \geq 0$ where $0 \leq t \leq \infty$ and

$$\int_0^{\infty} f_{a1}(t)dt = 1 \quad (5.13)$$

Further

$$F_{a1}(t) = \int_0^t f_{a1}(t)dt \quad (5.14)$$

It follows that $F_{a1}(0) = 0$, $F_{a1}(\infty) = 1$ and $f_{a1}(t) = dF_{a1}(t)/dt$. The average length of time an exchange line expends in State 1 is

²³For $k = 1, \dots, n$.

$$\mu_{a1} = \int_0^{\infty} t f_{a1}(t) dt \quad (5.15)$$

Define $F_{a0}^c(t)$ as the complement of $F_{a0}(t)$. $F_{a0}^c(t)$ is a non-decreasing function of t and $F_{a0}^c(t) = 1 - F_{a0}(t)$ and $F_{a0}^c(0) = 1$. Define $F_{a1}^c(t)$ as the complement of $F_{a1}(t)$. $F_{a1}^c(t)$ is a non-decreasing function of t and $F_{a1}^c(t) = 1 - F_{a1}(t)$ and $F_{a1}^c(0) = 1$. Given an alternating process defined by $f_{a0}(t)$ and $f_{a1}(t)$, we draw on renewal theory to make inferences about the evolution of the stochastic state of exchange lines.²⁴ If we have that $g(t)$ is a convolution of $f_{a0}(t)$ and $f_{a1}(t)$, now knowing that $G^c(t)/u_c$, has a Laplace transform,²⁵ $1 - \bar{g}(s)/u_c s$, we can substitute this in the formulation of the renewal function for a modified renewal process (see Eqn. B.5 in Appendix B) to derive the renewal function²⁶ of the equilibrium renewal process, as follows

$$\begin{aligned} \bar{H}_a^e(s) &= \frac{1 - \bar{g}(s)}{s\{1 - \bar{g}(s)\}} * \frac{1}{\mu_c s} \\ &= \frac{1}{\mu_c s^2} \end{aligned} \quad (5.16)$$

An inversion of the above gives²⁷

$$H_a^e(t) = \frac{t}{\mu_c} \quad (5.17)$$

where μ_c is the average length of a cycle.²⁸ The probability that a new cycle begins at t is derived by substituting $1 - \bar{g}(s)/\mu_c s$ for $\bar{g}_1(s)$ in (Eqn. B.11 in Appendix B), to give

²⁴For a detailed exposition of renewal theory see Pham-Gia and Turkkan (1999).

²⁵where $G^c(t)/u_c$ is the *pdf* of the first cycle of a modified process. See Pham-Gia and Turkkan (1999), and Cox (1967).

²⁶Captures average number of complete cycles in the interval $[0, t]$.

²⁷The inverse of $1/s^2$ is t . The inverse of $1/s$ is 1 - see Bolton (1994).

²⁸Here $\mu_c = \mu_{a0} + \mu_{a1}$.

$$\bar{h}_a^e(s) = \frac{1}{\mu_c s} \quad (5.18)$$

Therefore by inversion

$$h_a^e(t) = \frac{1}{\mu_c} \quad (5.19)$$

Now in an equilibrium renewal process, the probability that a process will be in State 1 at time t given that it was in the same state at the origin is made up of two components. First, that a State 1 interval prevailing at $t = 0$ persists until time t . The *pdf* of this interval is $F_a^c(t)/\mu_{a1}$. Second, there occurs a Type 0 event, at some time u , where $u < t$, followed by a Type 1 interval which persists for a period at least equal to $t - u$. Therefore we have that²⁹

$$\rho_{a11}^e(t) = \int_t^\infty \frac{F_{a1}^c(u)}{\mu_{a1}} du + \int_0^t h_{a10}^e(u) F_{a1}^c(t - u) du \quad (5.20)$$

here h_{a10}^e is the renewal density of a Type 0 failure, given that the process starts at the origin in State 1. Taking the Laplace transform of Eqn. 5.20 above, we have that³⁰

$$\bar{\rho}_{a11}^e(s) = \frac{(u_{a1}s - 1 + \bar{f}_{a1}(s))}{u_{a1}s^2} + h_{a10}^e \frac{(1 - \bar{f}_{a1}(s))}{s} \quad (5.21)$$

Drawing on Eqn. B.11 in Appendix B and recognizing that for an equilibrium renewal process the Laplace transform of the *pdf* for $L'(0)$ is $1 - \bar{f}_{a1}(s)/u_1s$, where we start with a Type 1 interval and end with a Type 0 interval, we have that

$$\bar{h}_{a10}^e(s) = \frac{\bar{f}_{a0}(s)(1 - \bar{f}_{a1}(s))}{u_{a1}s(1 - \bar{f}_{a0}(s)\bar{f}_{a1}(s))} \quad (5.22)$$

Substituting Eqn. 5.22 in Eqn. 5.21 we have that

²⁹See Pham-Gia and Turkkan (1999), and Cox and Miller (1965).

³⁰Using B.14 and B.16 in Appendix B.

$$\bar{\rho}_{a11}^e(s) = \frac{1}{s} - \frac{(1 - \bar{f}_{a0}(s))(1 - \bar{f}_{a1}(s))}{u_{a1}s^2(1 - \bar{f}_{a0}(s)\bar{f}_{a1}(s))} \quad (5.23)$$

From Eqn. 5.23, the following holds³¹

$$\lim_{t \rightarrow \infty} \rho_{a11}^e(t) = \frac{u_{a1}}{u_{a0} + u_{a1}} \quad (5.24)$$

Similarly, the following holds

$$\lim_{t \rightarrow \infty} \rho_{a01}^e(t) = \frac{u_{a1}}{u_{a0} + u_{a1}} \quad (5.25)$$

Therefore

$$\lim_{t \rightarrow \infty} \rho_{a1}^e(t) = \frac{u_{a1}}{u_{a0} + u_{a1}} \quad (5.26)$$

And

$$\rho_{a0}^e(t) = \frac{u_{a0}}{u_{a0} + u_{a1}} \quad (5.27)$$

For clarity of exposition, we let $\rho_{a1}^e(t) = \rho_a(t)$. Now the state of delivery points through space is defined on a probability space (Ω, ρ) where $\Omega = \{1, 0\}$ - the realizations $P_{at}(i)$ is 1 with a probability of $\rho_a(t)$ and 0 with a probability of $1 - \rho_a(t)$. We can therefore define the process describing the state of lines through space, at any time t , as a Bernoulli process.³²

So far we have assumed that the moments of $f_{a0}(t)$ and $f_{a1}(t)$ are constant. However these parameters will change through time with corresponding changes in $\rho_a(t)$. One would expect that $\rho_a(t)$ increases if the utilization of an access platform is increased and the converse is true if the utilization of an access platform is decreased. The evolution of $\rho_a(t)$ can be inferred from the data in the public domain and this evidence is used as a basis for the analysis in this

³¹See Pham-Gia and Turkkan (1999), and Cox and Miller (1965).

³²Similarly, through time we have it that the realizations $L_{ai}(t)$ is 1 with a probability of $\rho_a(t)$ and 0 with a probability of $1 - \rho_a(t)$.

chapter. We discuss the evolution of $\rho_a(t)$ in more detail in the next section.

5.5.2 Dynamic Intensity

The process $\rho_a(t)$ is defined based on observations from the period July 1999 to July 2007 - see data in Tables E.2 and E.3 in Appendix E. Based on this evidence we describe the intensity of exchange line activation as an Ito process, as follows

$$\frac{d\rho_a(t)}{\rho_a(t)} = \phi_{a\rho} dt + \sigma_{a\rho} dW(t)^{a\rho} \quad (5.28)$$

Here $\rho_a(t)$ is defined on a probability space $(\Omega, \mathcal{A}, \mathbb{P})$. The information set is captured by $\mathbb{F} = \{F_t : t \geq 0\}$. Further, $\rho_a(t)$ is F_t -measurable and is adapted to the same filtration. Now $\phi_{a\rho}$ is the drift of the process, $\sigma_{a\rho}$ its volatility and $dW(t)^{a\rho}$, a Weiner term. Now $0 \leq \rho_a(t) \leq 1$. The solution to Eqn. 5.28 is³³

$$\rho_a(t) | F_s = \rho_a(s) \exp \left(\left(\phi_{a\rho} - \frac{1}{2} \sigma_{a\rho}^2 \right) (t - s) + \sigma_{a\rho} W(t)^{a\rho} \right) \quad (5.29)$$

for $t > s$. The basis of this solution is as follows - we log transform the process in Eqn. 5.28 such that $\rho_a(t)^* = \ln \rho_a(t)$. Using Ito's lemma, the process followed by $\rho_a(t)^*$ is as follows³⁴

$$d\rho_a(t)^* = \left(\frac{\partial \rho_a(t)^*}{\partial \rho_a(t)} \phi_{a\rho} \rho_a(t) + \frac{\partial \rho_a(t)^*}{\partial t} + \frac{1}{2} \frac{\partial^2 \rho_a(t)^*}{\partial \rho_a(t)^2} \sigma_{a\rho}^2 \rho_a(t)^2 \right) dt + \frac{\partial \rho_a(t)^*}{\partial \rho_a(t)} \sigma_{a\rho} \rho_a(t) dW(t)^* \quad (5.30)$$

³³The constraint $0 \leq \rho_a(t) \leq 1$ is important. Eqn. 5.29 by itself does not however impose this constraint. For our purposes given $\rho_a(0)$, the volatility of the process $\sigma_{a\rho}$ and the window under consideration $[t(0), t(12)]$, the constraint is unlikely to be violated. If it was likely that the constraint would be violated then a modification of Eqn. 5.29 would be called for.

³⁴The model above assumes that $\sigma_{a\rho}$ is a constant. Evidence from data points at more frequent intervals and from a longer time series may suggest otherwise. The model above should therefore be seen as a first order model which could be developed further to accommodate any stochastic behaviour of $\sigma_{a\rho}$.

From Eqn. 5.30 above we have that³⁵

$$d\rho(t)^* = (\phi_{a\rho} - \frac{1}{2}\sigma_{a\rho}^2)dt + \sigma_{a\rho}dW(t)^* \quad (5.31)$$

Integrating Eqn. 5.31 above we have

$$\begin{aligned} \rho_a(t)^* | F_s &= \rho_a(s)^* + \int_s^t (\phi_{a\rho} - \frac{1}{2}\sigma_{a\rho}^2)du + \int_s^t \sigma_{a\rho}dW(u)^* \\ &= \rho_a(s)^* + \int_s^t (\phi_{a\rho} - \frac{1}{2}\sigma_{a\rho}^2)du + \sigma_{a\rho}W(u)^* \end{aligned} \quad (5.32)$$

We convert Eqn. 5.32 above into the original $\rho_a(t)$ term to obtain

$$\rho_a(t) | F_s = \rho_a(s) \exp \left((\phi_{a\rho} - \frac{1}{2}\sigma_{a\rho}^2)(t-s) + \sigma_{a\rho}W(t)^* \right) \quad (5.33)$$

Using the result in Eqn. 5.33, for a given set of sample data we have

$$\rho_a(t)^* - \rho_a(s)^* = (\phi_{a\rho} - \frac{1}{2}\sigma_{a\rho}^2)(t-s) + \sigma_{a\rho}(W(t)^* - W(s)^*) \quad (5.34)$$

From Eqn. 5.34 above it follows that

$$E[\rho_a(t)^* | F_s] = \rho_a(s) + (\phi_{a\rho} - \frac{1}{2}\sigma_{a\rho}^2)(t-s) \quad (5.35)$$

and the variance of the process is

$$Var[\rho_a(t)^* | F_s] = \sigma_{a\rho}^2(t-s) \quad (5.36)$$

Now while the primary premise of this thesis is that the risk associated with $\rho_a(t)$ is incorporated in $S_a(t)$, if the alternative argument is adopted then the valuation of a contingent claim on downstream value must be based on the

³⁵Knowing that $\frac{\partial \rho_a(t)^*}{\partial \rho_a(t)} = \frac{1}{\rho_a(t)}$; $\frac{\partial \rho_a(t)^*}{\partial t} = 0$; and $\frac{\partial^2 \rho_a(t)^*}{\partial \rho_a(t)^2} = -\frac{1}{\rho_a(t)^2}$

Q -dynamics of $\rho_a(t)$. The rationale and approach to defining the Q -dynamics of a counting process are perhaps best articulated by El Karoui and Martellini (2001) who provide an explicit expression for the martingale equivalent of the probability of non-default, in the case of defaultable securities. Unlike the case in El Karoui and Martellini (2001), where the first stopping time, defined by an underlying Poisson distribution of arrival times is relevant, in the case here the instantaneous probability of default takes the form of Eqn. 5.28. In both cases however the Q -dynamics of default or non-default can be derived using Girsanov's theorem. If we have that λ_2 is the market price of the risk of default, the Randon-Nikodym derivative, $L_{a\rho}(t) = dQ/dP | F_t$, can be used to derive the Q -dynamics of the process.³⁶ By Girsanov's Theorem, the Randon-Nikodym derivative for the change of measure of the P -Brownian motion is

$$L_{a\rho}(t) = \exp \left[- \int_0^t \lambda_2(s) dW(s) - \frac{1}{2} \int_0^t (\lambda_2(s))^2 ds \right] \quad (5.37)$$

where λ_2 is the price of the risk of default. Using Girsanov's Theorem, the relationship between the P and Q -Wiener processes is as follows

$$dW(t)^{a\rho} = d\widetilde{W}(t)^{a\rho} - \lambda_2 dt \quad (5.38)$$

where $d\widetilde{W}(t)^{a\rho}$ is a Q -Wiener process. Using Eqn. 5.38 the Q -dynamics of $\rho_a(t)$ is represented as follows³⁷

³⁶The market price of the risk of default can be interpreted as the price of a unit of volatility. It is a handle which transforms a process defined by a P -measure to a process defined by a Q -measure. This results in a relocation of the path of $\rho_a(t)$ to that that would prevail in a risk-neutral world.

³⁷We consider some corroborating evidence for the formulation in Eqn. 5.39. Duffie (2002) observes that $\frac{\lambda^Q}{\lambda^P}$ reflects the risk premium associated with the risk of default, in the context of the valuation of defaultable securities, and from the standpoint of a risk-neutral intensity process. Here λ^P and λ^Q and are the instantaneous probabilities of default under P and Q -dynamics, respectively. Based on similar arguments, we know from Bluhm et al. (2003) that $\rho_d^Q(t) \geq \rho_d^P(t)$ where $\rho_d(t)$ is the probability of default on a defaultable bond

$$\begin{aligned}
\frac{d\rho_a(t)}{\rho_a(t)} &= \phi_{a\rho}dt + \sigma_{a\rho}(d\widetilde{W}(t))^{a\rho} - \lambda_2dt \\
&= (\phi_{a\rho} - \sigma_{a\rho}\lambda_2)dt + \sigma_{a\rho}d\widetilde{W}(t)^{a\rho}
\end{aligned} \tag{5.39}$$

The Matlab Code for simulating $\rho_a(t)$ is in Appendix C (see M-File II).

5.6 Model Calibration

The parameters of $S_a(t)^*$ are calibrated using a two-step procedure.³⁸ Starting with Specification I, if we consider the trigonometric function in Eqn. 5.52, the parameters of $\alpha_{as}(t)$, i.e. $\beta_s, \xi_s, \eta_s, \omega_s$ and v_s , are determined by least squares estimation using the *cftool* function in Matlab. These parameters are estimated such that the sum of squares

$$\sum_{t=1}^n \| (S_a(t)^* - \alpha_{as}(t))^2 \| \tag{5.40}$$

is minimised. Next the parameters of the mean-reverting process i.e. $\gamma_{a\chi}$ and $\sigma_{a\chi}$ are estimated using Maximum Likelihood Estimation. Now letting $\chi_a(t) = S_a(t)^* - \alpha_{as}(t)$, we observe data $\chi_a = \{\chi_a(t_0), \chi_a(t_1), \dots, \chi_a(t_n)\}$ drawn from a population where $\chi_a(t_i)$ are independent and identically distributed. We use the Maximum Likelihood Estimation to solve for $\theta_{a\chi} = \{\gamma_{a\chi}, \sigma_{a\chi}\}$ such that the likelihood of observing the sample data is maximized. This is achieved by maximizing the following likelihood function.

$$\wedge(\theta_{a\chi}) = \prod_{i=0}^n f(\chi_a(t_i); \theta_{a\chi}) \tag{5.41}$$

³⁸This has been done to avoid over-fitting given the relatively low number observations, thereby giving emphasis to the overall trend. The one-step alternative approach is subsequently discussed.

To ease the computation, we convert Eqn. 5.41 above into a log-likelihood function $\ln [\wedge(\theta_{a\chi})] = L(\theta_{a\chi})$. Now $L(\theta_{a\chi})$ can be written as follows

$$\ln [\wedge(\theta_{a\chi})] = L(\theta_{a\chi}) = \ln \left[\prod_{i=0}^n f(\chi_a(t_i); \theta_{a\chi}) \right] = \sum_{i=0}^n \ln[f(\chi_a(t_i); \theta_{a\chi})] \quad (5.42)$$

Given $n + 1$ observations $\chi_a = \{\chi_a(t_0), \chi_a(t_1), \dots, \chi_a(t_n)\}$, knowing that its mean and variance are as represented in Eqn. A.9 and Eqn. A.10 in Appendix A, respectively, the transitional density of $\chi_a(t_i) | t_{i-1}$ is³⁹

$$f(\chi_a(t_i); \gamma_{a\chi}, \alpha_{a\chi}, \sigma_{a\chi}) = (2\pi)^{-\frac{1}{2}} \left(\frac{\sigma_{a\chi}^2}{2\gamma_{a\chi}} \left(1 - e^{-2\gamma_{a\chi}(t_i-t_{i-1})} \right) \right)^{-\frac{1}{2}} * \exp \left(-\frac{\left(\chi_a(t_i) - \alpha_{a\chi} - (\chi_a(t_{i-1}) - \alpha_{a\chi}) e^{-\gamma_{a\chi}(t_i-t_{i-1})} \right)^2}{2 \frac{\sigma_{a\chi}^2}{2\gamma_{a\chi}} \left(1 - e^{-2\gamma_{a\chi}(t_i-t_{i-1})} \right)} \right) \quad (5.43)$$

Using the result in Eqn. 5.43, the log-likelihood function can be written as follows

$$L(\chi_a(t_0), \chi_a(t_1), \dots, \chi_a(t_n); \gamma_{a\chi}, \alpha_{a\chi}, \sigma_{a\chi}) = -\frac{n}{2} \log \left(\frac{\sigma_{a\chi}^2}{2\gamma_{a\chi}} \right) - \frac{1}{2} \sum_{i=1}^n \log \left(1 - e^{-2\gamma_{a\chi}(t_i-t_{i-1})} \right) - \frac{\gamma_{a\chi}}{\sigma_{a\chi}^2} \sum_{i=1}^n \left(\frac{\left(\chi_a(t_i) - \alpha_{a\chi} - (\chi_a(t_{i-1}) - \alpha_{a\chi}) e^{-\gamma_{a\chi}(t_i-t_{i-1})} \right)^2}{\left(1 - e^{-2\gamma_{a\chi}(t_i-t_{i-1})} \right)} \right) \quad (5.44)$$

It is recognized that as an alternative to the aforesaid approach, all the unknowns can be estimated simultaneously. To illustrate, we observe sample data $S_a^* = \{S_a(t_0)^*, S_a(t_1)^*, \dots, S_a(t_n)^*\}$. We can use MLE to solve for $\theta_{as}^* = (\beta_s, \xi_s, \eta_s, \omega_s, v_s, \gamma_{bs}, \sigma_{bs}$ and $\alpha_{bs})$ such that the likelihood of observing the sample data is maximized. This is achieved by maximizing the following likelihood function

³⁹Note : $f(x_t; u, \sigma^2) = \frac{1}{\sqrt{2\pi\sigma^2}} \exp \left(\frac{-(x_t-u)^2}{2\sigma^2} \right)$

$$\wedge(\theta_{as}^*) = \prod_{i=0}^n f(S_a(t)^*; \theta_{as}^*) \quad (5.45)$$

Now

$$L(\theta_{as}^*) = \sum_{i=0}^n \ln[f(S_a(t)^*); \theta_{as}^*] \quad (5.46)$$

Here given $n + 1$ observations $S_a(t_0)^*, S_a(t_1)^* \dots S_a(t_n)^*$, the conditional density can be computed knowing that the mean and variance are as represented below⁴⁰. The essential difference between this and the previous approach is a shift from a 2-factor to a 8-factor maximization problem.

Turning to the calibration of $\rho_a(t)^*$, we observe data $\rho_a^* = \{\rho_a(t_0)^*, \rho_a(t_1)^* \dots \rho_a(t_n)^*\}$ drawn from a population where $\rho_a(t_i)^*$ are independent and identically distributed. We use the Maximum Likelihood Estimation to solve for $\theta_{a\rho} = \{\phi_{a\rho}, \sigma_{a\rho}\}$ such that the likelihood of observing the sample data is maximized. Now the conditional probability of the occurrence of $\rho_a(t_i)^* | F_{i-1}$ can be expressed as

$$f(\rho_a(t_i)^*; \phi_{a\rho}, \sigma_{a\rho}) = \frac{1}{\sqrt{2\pi\sigma_{a\rho}^2(t_i-t_{i-1})}} * \exp \left[-\frac{1}{2} \frac{(\rho_a(t_i)^* - \rho(t_{i-1})^* - (\phi_{a\rho} - \frac{1}{2}\sigma_{a\rho}^2)(t_i-t_{i-1}))^2}{\sigma_{a\rho}^2(t_i-t_{i-1})} \right] \quad (5.47)$$

The corresponding log-likelihood function is

⁴⁰The expectation with respect to $S_a(t)^*$

$$E^Q[S_a(t)^* | F_s] = (S_a(s)^* - \alpha_{as}^*(s))e^{-\gamma_{as}(t-s)} + \alpha_{as}^*(t)$$

where

$$\alpha_{as}^*(t) = \beta_s + \xi_s(t) + \eta_s \sin(\omega_s t + v_s)$$

We also have that

$$Var^Q[S_a(t)^* | F_s] = \frac{\sigma_{as}^2}{2\gamma_{as}} (1 - e^{-2\gamma_{as}(t-s)})$$

$$\begin{aligned}
& L(\rho_a(t_0)^*, \rho_a(t_1)^* \dots \rho_a(t_n)^*; \phi_{a\rho}, \sigma_{a\rho}) = \\
& -\frac{1}{2} \sum_{n=1}^n \left[\log[2\pi\sigma_{a\rho}^2(t_i - t_{i-1})] + \frac{\left(\rho_a(t_i)^* - \rho_a(t_{i-1})^* - \left\{\phi_{a\rho} - \frac{\sigma_{a\rho}^2}{2}\right\}(t_i - t_{i-1})\right)^2}{\sigma_{a\rho}^2(t_i - t_{i-1})} \right] \\
& + \log p(\rho_a(t_0)^*; \phi_{a\rho}, \sigma_{a\rho}) - \sum_{i=0}^n \log \rho_a(t_i)
\end{aligned} \tag{5.48}$$

The Matlab Code for the MLE based on Eqn. 5.44 is in Appendix C (see M-File IV) and that based on Eqn. 5.48 is in Appendix C (see M-File V).

5.7 Valuation

A framework for valuing the flexibility to adapt to the stochastic processes that create downstream value is presented in this section. The case where such flexibility can be exercised at the level of an exchange line is considered. Here an access seeker has separate rights to the trajectories defined by $S_{ai}(t)$, for each time interval. The study assumes the prevalent practice where capacity access to the local loop can be initiated or terminated within prescribed notice periods. Further, the study assumes the practice where access seekers mirror the lead times and other relevant conditions associated with wholesale service agreements onto retail service agreements, thereby accruing the value from being able to favourably align entry and exit. Since the $S_{ai}(t)$ trajectories pervade time and space, the access privileges can be depicted as a bundle of rights through the two dimensions.⁴¹ Therefore, through these dimensions, an access seeker has the leverage to exercise the right of access if a downstream

⁴¹An access seeker has the right to contract any consenting individual customer. Further, the average throughput represents the expected throughput per exchange line in a representative portfolio at a defined time interval. The analysis in this thesis assumes a large representative portfolio of delivery points, with connections and disconnections from the portfolio also being representative. Since the singleton lines entering and leaving the portfolio are representative, the expected throughput through each these is reflected by the average. This scenario differs from that where investment is made in a random standalone singleton line in isolation. The volatility of individual lines becomes relevant in such standalone investments.

market at the level of an exchange line exists. The access seeker does not however have the obligation to seek access when the downstream market dissipates. These rights are akin to financial call options because they confer rights, without corresponding obligations, to invest in $S_{ai}(t)$, for any time interval, at a pre-determined price during a regulatory lag. Such flexibility allows an access seeker to take advantage of the resolution of uncertainties and only seek access when these are resolved and when market circumstances justify such access.

The access seeker is therefore able to favourably align market entry and exit to the stochastic processes that generate value and in essence, for each time interval $[s, t]$, obtain the substantive equivalent of a contingent claim or derivative instrument defined on the underlying process, $S_{ai}(t)$. At each time interval, at the level of each delivery point, State 1 occurs with a probability of $\rho_a(t)$ and State 0 occurs with a probability of $1 - \rho_a(t)$. We implement the valuation using martingale pricing.⁴² The key argument in martingale pricing is the link between the absence of arbitrage and the existence of martingale measures. Harrison and Pliska (1983) provide proofs of the tenets of arbitrage pricing theory and show that a market is free of arbitrage if there exists a martingale measure; a market is complete if the martingale measure is unique; and the price of a contingent claim in an arbitrage free market is equivalent to the pay-offs of the claim under risk-neutral probabilities, discounted at the risk-free rate.

We have drawn on the intensity-based approach to contingent claim valuation. This approach finds application in circumstances where there exists a risk of default which is either totally or partially independent of the value of underlying assets. This approach therefore recognizes two main sources of risk i.e. market risk and asset-specific default risk. The intensity-based approach recognizes that at each instant, default can arise for reasons other than the value of the underlying asset. This approach takes into account the stochastic dynamics of the value of the underlying asset and the dynamics of default.

⁴²Martingale and risk-neutral pricing are used inter-changeably in this thesis.

Default is allowed to occur before the maturity of the underlying asset and is triggered by an exogenous process which is either fully or partially independent of the value of the underlying asset. The price of market risk and the price of the risk of default are used as the handles that define the martingale equivalents of the process that generates value.

With regard to the telecommunications capacity market, we argue that while constructing a hedging strategy on the spot process may not be feasible because the underlying asset cannot be carried forward through time, building such a strategy on the forward process is however feasible. We further argue that a forward price process can be reasonably inferred from the spot process given the relative stability of the constituent drivers of value. On inferring the forward price from the spot, because the underlying commodity cannot be carried forward through time, the traditional no-arbitrage relationship between the spot and a forward i.e. $F(s, t) = E[S(s)e^{(r-y)(t-s)} | \mathcal{F}_s]$ does not hold (here $t > s$). We know however that the price of a forward is equivalent to the price of the spot under risk-neutral expectations i.e. $F(s, t) = E^Q[S(t)]$. Now from Section 5.3.1, downstream value given an activated state is

$$S_a(t) = X_a(t) (Y_a(t) - U_a(t)) + V_a(t) - M_a(t) \quad (5.49)$$

Knowing that $Y_a(t)$, $U_a(t)$, $V_a(t)$ and $M_a(t)$ are relatively deterministic and letting $\kappa = Y(t) - U(t)$ and $\beta_2 = V_a(t) - M_a(t)$, we have

$$S_a(t) = X_a(t)\kappa + \beta_2 \quad (5.50)$$

Letting $S_a(t)^* = \ln S_a(t)$, the evolution of downstream value can be represented as

$$dS_a(t)^* = \gamma_{as}(\alpha_{as}(t) - S_a(t)^*)dt + \sigma_{as}dW(t)^{as} \quad (5.51)$$

The seasonal variation exhibited by $S_a(t)^*$ is described as an ordinary trigonometric function, as follows

$$\alpha_{as}(t) = \beta_s + \xi_s(t) + \eta_s \sin(\omega_s t + v_s) \quad (5.52)$$

where β_s , ξ_s , η_s , ω_s and v_s are constants. Here $\xi_s(t)$ captures the drift of $S_a(t)^*$ through time. Now β_s , η_s , ω_s and v_s capture the other usual parameters of an ordinary trigonometric function. Now by Girsanov's Theorem, the Radon-Nikodym derivative for the change of measure of the P -Brownian motion is

$$L_{as}(t) = \exp \left[- \int_0^t \lambda_1(s) dW(s) - \frac{1}{2} \int_0^t (\lambda_1(s))^2 ds \right] \quad (5.53)$$

where λ_1 is the market price of risk. Using Girsanov's Theorem, the relationship between the P and Q -Weiner processes are as follows

$$dW(t)^{as} = d\widetilde{W}(t)^{as} - \lambda_1 dt \quad (5.54)$$

where $d\widetilde{W}(t)$ is a Q -Weiner process. The process describing the evolution of $S_a(t)^*$ under risk-neutral expectations is

$$dS_a(t)^* = \gamma_{as} \left(\alpha_{as}(t) - S_a(t)^* - \frac{\lambda_1 \sigma_{as}}{\gamma_{as}} \right) dt + \sigma_{as} d\widetilde{W}(t) \quad (5.55)$$

The expectation with respect to Eqn. 5.55 is

$$E^Q[S_a(t)^* | F_s] = (S_a(s)^* - \alpha_{as}^*(s)) e^{-\gamma_{as}(t-s)} + \alpha_{as}^*(t) \quad (5.56)$$

where

$$\alpha_{as}^*(t) = \beta_s + \xi_s(t) + \eta_s \sin(\omega_s t + v_s) - \frac{\lambda_1 \sigma_{as}}{\gamma_{as}}$$

Or more simply

$$\alpha_{as}^*(t) = \alpha_{as}(t) - \frac{\lambda_1 \sigma_{as}}{\gamma_{as}} \quad (5.57)$$

Drawing on Eqn. 5.6 we have that

$$Var^Q[S_a(t)^* | F_s] = \frac{\sigma_{as}^2}{2\gamma_{as}}(1 - e^{-2\gamma_{as}(t-s)}) \quad (5.58)$$

For simplicity of exposition letting $\mu_{as}(t) = E^Q[S_a(t)^* | F_s]$ and $\sigma_{af} = Var^Q[S_a(t)^* | F_s]$, for the Q -dynamics, knowing from the lognormal properties of $S_a(t)^*$ that $S_a(t) = e^{\mu_{as}(t) + \frac{1}{2}\sigma_{af}^2}$, we have that

$$E^Q[S_a(t) | F_s] = \exp \left[(S_a(s)^* - \alpha_{as}^*(s))e^{-\gamma_{as}(t-s)} + \alpha_{as}^*(t) + \frac{\sigma_{as}^2}{4\gamma_{as}}(1 - e^{-2\gamma_{as}(t-s)}) \right] \quad (5.59)$$

If we take $S_a(t)$ and $p_a(t)$ to be separate and independent processes in the short-run, and therefore the risk associated with the latter is incorporated in former, i.e. Scenario I, knowing that a rational access seeker will align entry and exit such that for any time interval $F(S_a(t); t, t) > K$, the value of a contingent claim on $S_a(t)$ incorporating the stochastic intensity of line activation, is⁴³

$$C(s, F(s, t); K_a, t) = E[F(S_a(t); t, t) - K_a, 0]^+ * E[\rho_a(t)] * e^{-r(t-s)} \quad (5.60)$$

where $E[\rho_a(t)]$ is the intensity of exchange line activation under objective measures. If on the other hand it is assumed that the risk associated with $\rho_a(t)$ is not incorporated in $S_a(t)$, i.e. Scenario II, then the value of a contingent claim on $S_a(t)$ incorporating the stochastic intensity of line activation, is

⁴³From the evidence in Chapter 8, the correlation between $Y_a(t)$ and $\rho_a(t)$ is spurious, at least in the short run. Based on this evidence any correlation between the noise terms of the two processes, if any, is not investigated further.

$$C(s, F(s, t); K_a, t) = E[F(S_a(t); t, t) - K_a, 0]^+ * E^Q[\rho_a(t)] * e^{-r(t-s)} \quad (5.61)$$

where $E^Q[\rho_a(t)]$ is the risk-neutral intensity of exchange line activation. The alternative assumptions underlying Scenarios I and II are deemed to be the two most plausible ways of investigating the questions that are the subject of this thesis. A third contender is not obvious. The Matlab code for simulating $S_a(t)$ under risk-neutral expectations is in Appendix C (see M-File I). The Matlab codes corresponding to Eqn. 5.60 and Eqn. 5.61 are in Appendix C (see M-File III). Analytical solutions corresponding to Eqn. 5.60 and Eqn. 5.61 are developed in Chapter 7. The results and discussion are in Chapter 8.

5.8 Summary

Mandatory capacity access in telecommunication capacity networks raises the question of the value of the differentiated abilities of the access provider and access seekers to adapt to the stochastic dynamics of downstream value at the level of delivery points - more specifically, their differentiated abilities to adapt to the migration of the upside and the downside between delivery points in a network. This chapter has developed a framework for valuing the flexibility of adapting to downstream value, and tested the neutrality of FL-LRIC as an approach for pricing capacity access, based on evidence from the analogue platform. Contingent claim pricing theory is used as a theoretical framework. This pricing theory has been used because of its capacity to conceptualize and quantify the value of flexibility. A numerical method, Monte Carlo simulation, is used because of its capacity to value complex derivatives defined by multi-dimensional stochastic processes. Maximum Likelihood Estimation is used to calibrate the stochastic differential equations describing downstream value and the value of the underlying contingent claims are estimated using martingale pricing.

We draw on intensity-based approaches to contingent claim valuation. This approach takes into account the stochastic dynamics of the value of the underlying asset and the dynamics of default. Default is triggered by an exogenous process which is either fully or partially independent of the value of the underlying asset. The market price of risk and the market price of the risk of default are used as the handles that define the martingale equivalents of the process that generates value.

In summary, this chapter has developed an approach for valuing contingent claims in the analogue platform. This is approach together with the evidence from the residential analogue market in the UK form the basis of the numerical analysis that test the symmetry or otherwise of FL-LRIC. The results are discussed in Chapter 8.

Chapter 6

ADSL CAPACITY ACCESS: CONTINGENT CLAIM ANALYSIS

6.1 Introduction

This chapter develops a framework for valuing the flexibility of adapting to downstream value, and tests the neutrality of FL-LRIC as an approach for pricing capacity access, based on evidence from the ADSL platform. This evidence is from the 8 mbit/s subscriber access capacity in the UK and covers the period January 2000 to December 2008.¹ As with the analysis of the analogue voice capacity access market in Chapter 5, option pricing theory is used as a theoretical framework.² This pricing theory is used because of its capacity to conceptualize and quantify the value of flexibility. A numerical method, Monte Carlo simulation, is used as an analytical tool because of its capacity to value complex derivatives defined by multi-dimensional stochastic processes. Maximum Likelihood Estimation is used to calibrate the stochastic differential equations describing downstream value and the value of the underlying contingent claims are estimated using martingale pricing principles.

Being a different technology platform, the ADSL data capacity access network necessarily presents important differences to the analogue network from a contingent claim perspective. For example, downstream value to an access seeker in the ADSL network, for a provisioned capacity, in the main, is independent of traffic. Further, conveyance in the ADSL network is effected through a system of virtual paths. This contrasts the meshed connectivity in the analogue voice platform. Despite these differences there are important similarities

¹The rationale for this coverage is discussed in Chapter 4.

²Option pricing theory and contingent claim pricing theory are used inter-changeably in this thesis.

between the two platforms – for example, capacity access to the local loop confers downstream rights in both platforms. Because of these similarities, there is an inevitable overlap between the analysis in this chapter and that in Chapter 5 on, for example, the substantive nature of access to the local loop and the stochastic dynamics defining exchange line activation. A descriptive overview of the ADSL access network is presented in Section 6.2. The model describing downstream value and its constituent parts are discussed in Sections 6.3 to 6.5. Section 6.6 presents a framework for calibrating the model. Section 6.7 provides a framework for valuing a contingent claim on the process defining downstream value. Closed-form analytical solutions are developed in Chapter 7. The results and discussion are covered in Chapter 8.

6.2 Network Topology

6.2.1 Downstream and Upstream Markets

The downstream data market comprises three products - narrowband, and symmetric and asymmetric broadband.³ These three products are differentiated, in the main, by capacity (bandwidth), and hence quality and service range distinctions. Narrowband provides capacities of up to 56 kbit/s over analogue lines, 64 kbit/s over ISDN 2 digital channels and 128 kbit/s over double-bonded ISDN 2 digital channels. Symmetric and asymmetric broadband provide capacities greater than 128 kbit/s. At the first level in the hierarchy, narrowband is differentiated from asymmetric broadband by its lesser capabilities which create demand-side distinctions and separate economic markets. At the next level in the hierarchy, asymmetric broadband is differentiated from symmetric broadband by its lesser capabilities which also create demand-side distinctions and

³The source of data for this descriptive overview includes Ofcom (2004a) - Direction Setting the Margin between IPStream and ATM interconnection Prices; Ofcom (2004b) - Review of Wholesale Broadband Markets Access Markets; Ofcom. (2005c) - Valuing Copper Access; Ofcom (2006) - Review of Wholesale Broadband Markets 2006/7; Ofcom (2007) - The UK Communications Market; Oftel (2002) - Direction to Resolve a Dispute between BT, Energis and Thus Concerning Xdsl Interconnection at the ATM Switch.

separate economic markets. Asymmetric access provides maximum downloading capacity but a lower uploading capacity while symmetric access provides equal bandwidth for downloading and uploading.

ADSL-enabled fixed-wire and cable are currently the dominant access platforms for asymmetric broadband access and account for over 99% of the data market in the UK (Ofcom, 2004a). Cable accounts for 40% of the market and currently exerts appreciable competitive pressure on ADSL-enabled access. Alternative access platforms include Wireless Fidelity (WiFi), Broadband Fixed Wireless Access (BFWA), Worldwide Interoperability for Microwave Access (WiMax), Mesh Networks, satellite, power line technology and free space optics. These alternative platforms do not at present exert appreciable competitive pressure on either ADSL and cable platforms because of their lesser service capabilities. This research focuses on the 8 mbit/s downstream market which constitutes 43% of the data market in the UK (see Ofcom, 2007).

The UK market can be stratified into three segments based on the homogeneity of the competitive conditions (Ofcom, 2006). These segments include: (i) Market 1 - exchanges where BT is the only operator; (ii) Market 2 - exchanges where there are 2 or 3 operators and exchanges where there are 4 or more operators and where there are less than 10,000 delivery points⁴; (iii) Market 3 - exchanges where there are 4 or more operators and where there are more than 10,000 delivery points. BT, cable operators and LLUs account for 98%, 2% and 0% of Market 1, respectively; 73%, 26% and 1% of Market 2; and 56%, 34% and 10% of Market 3. Markets 1, 2 and 3 have an average of 1,600, 8,000 and 19,000 delivery points per exchange, respectively.

Based on considerations of the incumbent's current and prospective market shares, barriers to entry and expansion, economies of scale and scope, and countervailing market power, it is concluded from a regulatory standpoint, that the incumbent has significant market power in Markets 1 and 2, hence the basis for regulating capacity access (Ofcom, 2006). These conditions are weaker in

⁴Exchange lines

Market 3 but not sufficiently so in the current conditions to conclude, from a regulatory standpoint, that the incumbent does not wield significant market power. It has been argued that regulation is necessary to promote competition. It is further argued that without such intervention competition in the downstream and upstream markets would be constrained (Ofcom, 2006).

At the time of this study the UK access market had 5,587 local exchanges with 972 of these having between 10,000 to 66,000 delivery points; 1,268 between 2,500 and 10,000 delivery points; 1,073 between 1,000 and 2,500; 1,031 between 500 and 1,000; and 1,243 up to 500 delivery points (see Figure F.1 in Appendix F). At the same time cable had 95%+ presence in the service areas covered by 48 local exchanges; 65-95% presence in the service areas covered by 816 exchanges; 30-65% presence in 293; 5%-30% in 164; and up to 5% in 4,266. Overall 857 exchanges included in the first two clusters serve 45% of the delivery points in the UK (see Figure F.2 in Appendix F). This suggests that retail consumers have a choice of more than one access platform in about one half of the downstream market and the risk of stranded assets is therefore real. This puts into perspective the question of the value of the flexibility to adapt to the downstream stochastic processes that generate value.

6.2.2 Network Structure

Like the analogue network, the data network comprises twisted copper pairs connected to a core network of exchanges. Unlike the analogue network, the capacity of the copper wire in the data network is enhanced through the Asynchronous Digital Subscriber Line (ADSL) technology which enables digital data transmission over the twisted copper wire. While the traditional copper pair has frequencies between 0 Hz and 3.4 Hz with speeds up to 56 kbit/s, ADSL achieves speeds above 256 kbit/s. ADSL enhances the capacity of the copper wire by enabling broadband transmission while still supporting voice transmission. In the ADSL network, the splitter at either end of the subscriber access network divides the frequency band into low and high frequency portions (see

Figure 6.1). This allows the twisted copper wire to provide normal telephony services in the 0 to 3.4 kHz range, data upload in the 30 kHz to 138 kHz range and data download at speeds up to 1,104 kHz.

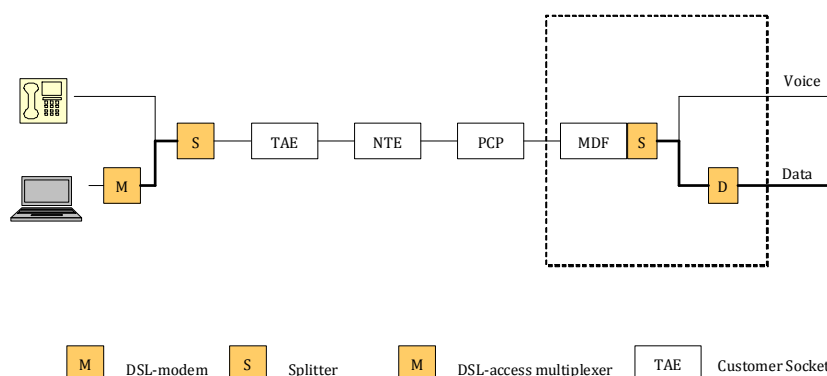

Source : WIK (2005)

Figure 6.1: DSL - Subscriber Line

The ADSL network is structurally divided into four main layers - Subscriber Access Network, Backhaul Link and ATM Network and the ISP Link. The corresponding capacity services include End User Access (EUA), ATM Backhaul, ATM Conveyance and the ISP Link Conveyance. The Subscriber Access Network comprises the infrastructure connecting a subscriber's premise to the Digital Subscriber Line Access Multiplexer (DSLAM) at the exchange. The Subscriber Access Network therefore includes the NTE, PCP and MDF (see Figure 6.2). The EUA costs are driven by the number of end users and comprise connection, rental and port reservation costs.

The DSLAM connects the subscriber lines to the core network. The DSLAM, commonly situated at the exchange, combines signals from subscriber lines

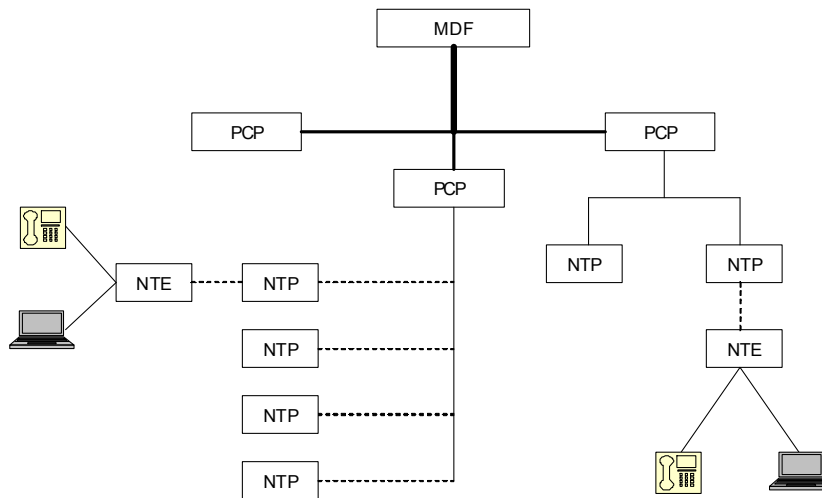

Source : WIK (2005)

Figure 6.2: Subscriber Access Network

through multiplexing, and channels these to the core network. In addition the DSLAM acts as a switch. The ATM Backhaul (Backhaul Link) comprises the infrastructure that links the DSLAM to the first point of interconnection in the core network (parent node). The core network comprises the nodes in the ATM network. ATM Conveyance comprises the conveyance of traffic between the nodes in the core network. The cost of backhaul, ATM conveyance and the ISP Link conveyance is driven by the dimensioned capacity (bandwidth), which is in turn a function of projected traffic.

An access seeker may interconnect with an incumbent's network at one of four possible points – the DSLAM at the local exchange, parent node, distant node or at the Customer Service Link (see Figure 6.3). Local Loop Unbundling refers to the first offer where the incumbent provides only EUA. To provide end-to-end connectivity from the Subscriber Access Network, Virtual Paths (VP)

are created. In the ADSL network, while each EUA is dedicated to an end user and is therefore not contented, the VPs are usually contented in a ratio of 50:1 for residential connections and a ratio of 20:1 for business connections. In the UK, ATM Backhaul is provided in capacities of 0.25, 0.5, 1, 2, 3, 4, 5, 6, 7, 8, 9 and 10 mbit/s. And ATM Conveyance is available in the following capacities of 0.25, 0.5, 1, 2, 3, 4, 5, 6, 7, 8, 9 and 10 mbit/s. It should however be noted that the range of these offerings vary from time to time. The cost of the VPs depends on length and there exists three price categories – handover, local (less than 10 km), regional (between 10 and 150 km) and national (over 150 km) - see Ofcom (2004a).⁵

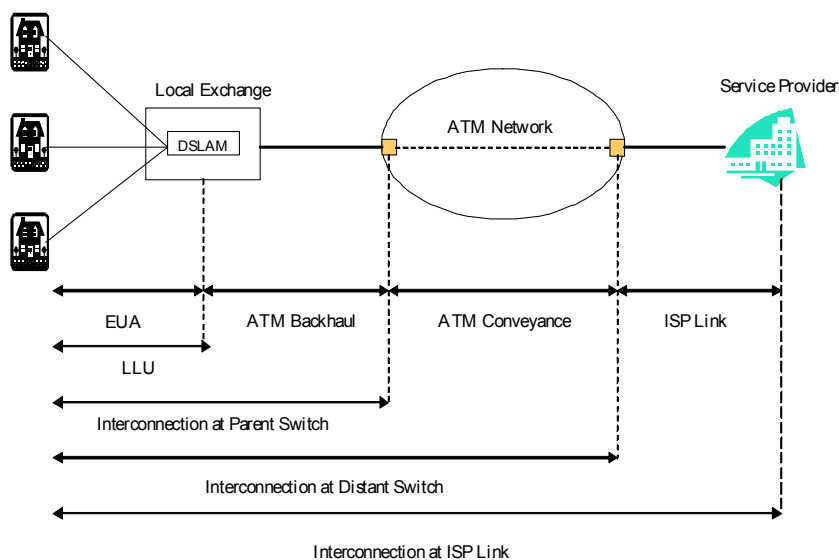

Source: Ofcom (2006)

Figure 6.3: Capacity Access

⁵See Tables E.7 - E.9 in Appendix E.

6.3 Model Specification

6.3.1 General

There are four key distinctions between the ADSL platform studied in this chapter and the analogue platform chapter studied in Chapter 5. First, in the ADSL platform, for a provisioned capacity, downstream value to an access seeker per exchange line is independent of traffic.⁶ This is unlike the analogue platform where downstream value to an access seeker is primarily driven by traffic. Second, downstream value in the analogue platform, unlike the ADSL platform, exhibits seasonal variation. Third, unlike the analogue voice service, conveyance of data in the ADSL platform is effected through a system of dedicated virtual paths (VPs). This contrasts the any-to-any connectivity in the analogue voice platform. A VP comprises the connection between the DSLAM and the point of connection with an internet service provider (ISP). The VP includes the backhaul link between the DSLAM and the parent node, and if required, conveyance between the ATM nodes. The VP also includes the ISP Link, which is the connection between the last ATM terminal node and the service provider. In the ADSL network, while each EUA is dedicated to an end user and is therefore not contented, the VPs are usually contented.

Fourth, while downstream value is in part impacted by the risk of de-activation, as in the case of the analogue platform, the dynamics of exchange line activation and de-activation in a representative portfolio of ADSL exchange lines through time will be driven by the *pdfs* of the two alternative states which may be fundamentally different from the corresponding functions for the analogue platform. Because of this, the exposition in this chapter runs parallel to that in Chapter 5, to emphasize these differences and remove any ambiguity but at the expense of some duplication of exposition.

Despite these differences there are important similarities between the two

⁶It is noted that there exist some downstream products where downstream value depends on traffic. This study focuses on the former market.

platforms – for example, capacity access to the local loop confers downstream rights in both platforms. Because of these similarities, there is minor overlap between the analysis in this chapter and that in Chapter 5 on, for example, the substantive nature of access to the local loop.

6.3.2 Downstream Value

Where mandatory capacity access is provided for, third-party access to the Subscriber Access Network confers downstream rights to an access seeker. As with the analogue capacity access market, the price of access to the Subscriber Access Network constitutes the substantive equivalent of a strike price, from a contingent claim standpoint, for four main reasons. First, this price allows an access seeker to participate in the downstream market. Second, the access price is fixed for a specified period (regulatory lag). Third, the downstream market is characterized by uncertainty with both a potential upside and a downside. Fourth, the right to participate in the downstream market does not have a corresponding obligation.

Given a portfolio of delivery points, the rights conferred to an access seeker can be depicted as a two-dimensional bundle of discrete rights - with rights through space in the first dimension and rights through time in the second. The states of the delivery points are however stochastic through space and time. The alternative states of a delivery point are either a non-activated state which we refer to as State 0 or an activated state which we refer to as State 1. An ADSL line may remain in either state or oscillate variously between the two states during a regulatory lag. The state of an exchange line and the related dynamics are important from the standpoint of contingent claim analysis, for two reasons. First, the flexibility of an access seeker in the ADSL market can be exercised at the level of an exchange line. Second, the state of a line is a primary driver of downstream value.

We study the predominant case where a third-party uses capacity access in the broadband access market to provide only data services and where such

a party purchases end-to-end connectivity. In the ideal situation, the single key statistic required for contingent claim analysis is that which captures the evolution of average downstream value of exchange lines in the ADSL platform. This is however not available as a single statistic from the data in the public domain. What is however available is data that captures the constituent parts of such value (tariffs per unit of time, conveyance charges per unit of time etc). This study is based on such secondary evidence. Now if we consider a representative portfolio of ADSL delivery points, in the 8 mbit/s end-user capacity market, the downstream value of the i^{th} line to an access seeker, for $i = 1, \dots, n$, in the constrained case,⁷ is

$$Z_{bi}(t) = \begin{cases} Y_b(t) - U_b(t) - M_b(t) - K_b(t) & \text{if } L_{bi}(t) = 1 \\ -\nu U_b(t) - \nu M_b(t) - K_b(t) & \text{if } L_{bi}(t) = 0 \end{cases} \quad (6.1)$$

The subscript b distinguishes the ADSL platform from the analogue platform studied in Chapter 5. Now $Y_b(t)$ represents the evolution of average tariffs per exchange line per unit time, $U_b(t)$ the average price of a virtual path per unit time, $M_b(t)$ other costs and $K_b(t)$ the regulated price of access to the Access Network. $L_{bi}(t)$ represents the state of an exchange line. The processes $Y_b(t)$ and $L_{bi}(t)$ are stochastic while $U_b(t)$ and $M_b(t)$ are relatively deterministic.⁸ Now ν represents the proportion of capacity that cannot be re-assigned. An access seeker has the right to the downstream value described by $S_{bi}(t)$ subject to a payment, $K_b(t)$.⁹ $K_b(t)$ is therefore the substantive equivalent of a strike price, from a contingent claim standpoint. Now the dynamics across lines, for a given point in time, can be represented as follows

$$Z_{bt}(i) = \begin{cases} Y_b(t) - U_b(t) - M_b(t) - K_b(t) & \text{if } P_{bt}(i) = 1 \\ -\nu U_b(t) - \nu M_b(t) - K_b(t) & \text{if } P_{bt}(i) = 0 \end{cases} \quad (6.2)$$

⁷If we ignore for the time being the flexibility to adapt to downstream stochastic processes.

⁸See BT Broadband Wholesale - <http://www.btwholesale.com>

⁹ $S_{bt}(i) = \begin{cases} Y_b(t) - U_b(t) - M_b(t) & \text{if } P_{bt}(i) = 1 \\ -\nu U_b(t) - \nu M_b(t) & \text{if } P_{bt}(i) = 0 \end{cases}$

for $t = 1, \dots, n$ and $i = 1, \dots, n$, where $P_{bt}(i)$ defines the state of the i^{th} of element of a representative portfolio of exchange lines at time t in the analogue platform. Now $P_{bt}(i) = 1$ with a probability $\rho_b(t)$ or 0 with a probability $1 - \rho_b(t)$. We discuss the algorithms that capture $L_{bi}(t)$ and $\rho_b(t)$ in Section 6.4. Before then, we examine the $S_b(t)$ process more closely in the next section.

6.3.3 Tariffs and Downstream Value

Broadband was first delivered through BT's infrastructure from about 2000. Intra-platform competition for broadband services in BT's infrastructure was introduced around 2004 before subsequently taking a fairly strong hold in 2005/6. Now $Y_b(t)$ is defined based on observations from January 2000 to December 2008 using two sets of data. The first set shows the evolution of BT's retail tariffs for the 8 mbit/s product (BT Option 1).¹⁰ The second set shows the evolution of tariffs of comparable competing retail products offered by BT's competitors.¹¹ Read together the data from the two sources shows, customary with new product launches, a drift towards a mean-reverting steady state. The noise around the mean is explained by changing tariff differentials between the competing service providers, shifting market shares, changing levels of promotional discounts from the various service providers and changing churn patterns. The observed mean-reverting process in the steady state is similar to the process observed in the electricity sector where the spot price process oscillates around a mean which reflects the medium to long-run cost of production (see for example Lucia and Schwartz, 2002). The observed mean-reverting state is the basis of the analysis in this chapter. Accordingly $Y_b(t)$ is defined as a mean-reverting process. Now knowing that $Y_b(t)$ is a mean-reverting process in the steady state and that $U_b(t)$ and $M_b(t)$ are relatively deterministic during

¹⁰Source: Point Topic (<http://point-topic.com/>). See Table E.4 in Appendix E. The coverage from this source covers the period January 2000 to December 2008.

¹¹Source: Pure Pricing (<http://www.purepricing.co.uk/>). See Table E.5 in Appendix E. The coverage from this source is limited to the period December 2006 to December 2008.

a regulatory lag, the process $S_b(t)$ given $L_{bi}(t) = 1$, is also necessarily mean-reverting.¹² Letting $S_b(t)^* = \ln S_b(t)$, we have that the process followed by the logarithm of the spot price, given $L_{bi}(t) = 1$, is

$$dS_b(t)^* = \gamma_{bs}(\alpha_{bs} - S_b(t)^*)dt + \sigma_{bs}dW(t)^{bs} \quad (6.3)$$

Here $S_b(t)^*$ is defined on a probability space $(\Omega, \mathcal{A}, \mathbb{P})$. The information set is captured by $\mathbb{F} = \{F_t : t \geq 0\}$. Further, $S_b(t)^*$ is F_t -measurable and is adapted to the same filtration. Now α_{bs} is the level around which the process fluctuates, γ_{bs} the speed of reversion to the mean and σ_{bs} the volatility of the noise term.¹³ The process has a positive drift at a rate of γ_{bs} when $\alpha_{bs} > S_b(t)^*$ and a negative drift of the same rate when $\alpha_{bs} < S_b(t)^*$. Now α_{bs} is a constant and $W(t)^{bs}$ is Wiener process.¹⁴ The expectation with respect to Eqn. 6.3 under objective measures, for $t > s$, is

$$E^P[S_b(t)^* | F_s] = S_b(s)^* e^{-\gamma_{bs}(t-s)} + \alpha_{bs}(1 - e^{-\gamma_{bs}(t-s)}) \quad (6.4)$$

Drawing on the proof in Appendix A, and based on the corollary in Section 5.3.2, we have

$$Var[S_b(t)^* | F_s] = \frac{\sigma_{bs}^2}{2\gamma_{bs}}(1 - e^{-2\gamma_{bs}(t-s)}) \quad (6.5)$$

Drawing on Eqn. 6.4 and Eqn. 6.5, the solution to Eqn. 6.3 is

¹²The subscript/postscript b distinguishes the ADSL platform from the analogue platform studied in Chapter 5 and the subscript/postscript s denotes the process defining the evolution of tariffs.

¹³As will be discussed more exhaustively in Chapter 8, the data shows that the correlation between $Y_b(t)$ and $\rho_b(t)$ is spurious, at least in the short run.

¹⁴The model above assumes that γ_{bs} , σ_{bs} and α_{bs} are constant. Evidence from data points obtained from more frequent intervals and from a longer time series may suggest otherwise. The model above should therefore be seen as a first order model which could be developed further to accommodate alternative stochastic behaviour of γ_{bs} , σ_{bs} and α_{bs} .

$$S_b(t)^* = S_b(s)^* e^{-\gamma_{bs}(t-s)} + \alpha_{bs}(1 - e^{-\gamma_{bs}(t-s)}) + \sigma_{bs} \sqrt{\frac{1 - e^{-2\gamma_{bs}(t-s)}}{2\gamma_{bs}}} \varepsilon \quad (6.6)$$

where ε is a random number drawn from a standard normal distribution. The risk-neutral process corresponding to Eqn. 6.3, for $t > s$, can be represented as follows

$$dS_b(t)^* = \gamma_{bs}(\alpha_b^* - S_b(t)^*)dt + \sigma_{bs}d\widetilde{W}(t)^{bs} \quad (6.7)$$

Here $\alpha_b^* = \alpha_{bs} - \lambda_1 \sigma_{bs} / \gamma_{bs}$, where λ_1 is the price of market risk and $d\widetilde{W}(t)^{bs}$ is a Q -Wiener process. The basis of this formulation is as follows - by Girsanov's Theorem, the Radon-Nikodym derivative for the change of measure is

$$L_{bs}(t) = \exp \left[- \int_0^t \lambda_1(s) dW(s) - \frac{1}{2} \int_0^t (\lambda_1(s))^2 ds \right] \quad (6.8)$$

Using Girsanov's Theorem, the relationship between the P and Q -Wiener processes are as follows

$$dW(t)^{bs} = d\widetilde{W}(t)^{bs} - \lambda_1 dt \quad (6.9)$$

where $d\widetilde{W}(t)^{bs}$ is a Q -Wiener process. From Eqn. 6.3 and Eqn. 6.9 we have that

$$\begin{aligned} dS_b(t)^* &= \gamma_{bs}(\alpha_{bs} - S_b(t)^*)dt + \sigma_{bs}(d\widetilde{W}(t)^{bs} - \lambda_1 dt) \\ &= \gamma_{bs} \left(\alpha_{bs} - \frac{\lambda_1 \sigma_{bs}}{\gamma_{bs}} \right) dt + \sigma_{bs} d\widetilde{W}(t)^{bs} \end{aligned} \quad (6.10)$$

Therefore¹⁵

¹⁵See arguments similar to those above in Lucia and Shwartz (2002).

$$\alpha_{bs}^* = \alpha_{bs} - \frac{\lambda_1 \sigma_{bs}}{\gamma_{bs}} \quad (6.11)$$

And, following from Eqn. 6.4, the expected value of $S_b(t)^*$ under risk-neutral assumptions is

$$E^Q[S_b(t)^* | F_s] = S_b(s)^* e^{-\gamma_{bs}(t-s)} + \alpha_{bs}^* (1 - e^{-\gamma_{bs}(t-s)}) \quad (6.12)$$

And

$$Var^Q[S_b(t)^* | F_s] = \frac{\sigma_{bs}^2}{2\gamma_{bs}} (1 - e^{-2\gamma_{bs}(t-s)}) \quad (6.13)$$

The Matlab code for simulating the $S_b(t)$ process under risk-neutral expectations is in Appendix D (see M-File I).

6.4 Intensity of Exchange Line Activation

6.4.1 Intensity in Equilibrium

As with the analogue network, it is recognized that at each instant through time, there is a possibility that an ADSL activated line may be de-activated, or vice versa, for reasons which may or may not be dependent on tariffs. Activation or de-activation can therefore occur at any time during the useful life of an ADSL exchange line, and either is conceived as being triggered by an exogenous process that is fully or partially independent of $Y_b(t)$. As with the analysis in Chapter 5, the dynamics of activation and de-activation are explored, through space/time,¹⁶ as an on-off or a renewal process and second through time/space,¹⁷ as a Bernoulli process. This enables the analysis in this chapter to mirror the essence of retail service contracts, and then transition to empirical and more rigorous analysis. While the dynamics of exchange line ac-

¹⁶With space in the first dimension and time in the second.

¹⁷With time in the first dimension and space in the second.

tivation and de-activation in a representative portfolio of ADSL exchange lines through time will be driven by the *pdfs* of the two alternative states, $f_{b_0}(t)$ and $f_{b_1}(t)$, it is recognised that these two functions may be fundamentally different from the corresponding functions for the analogue platform $f_{a_0}(t)$ and $f_{a_1}(t)$. It therefore necessarily follows that Laplace functions, $\bar{f}_{a_0}(s)$ and $\bar{f}_{a_1}(s)$ may well be different from $\bar{f}_{b_0}(s)$ and $\bar{f}_{b_1}(s)$. Because of this, the exposition in this chapter runs parallel to that in Chapter 5, to emphasize these differences and remove any ambiguity, at the expense of some duplication of exposition.

Now define $f_{b_0}(t)$ as the *pdf* and $F_{b_0}(t)$ the *cdf* of the random variable,¹⁸ $L_b(k)$, time expended in State 0 by elements of a representative portfolio of ADSL exchange lines.¹⁹ It is assumed that the realizations of $L_b(k)$ are independent and identically distributed. It follows that $F_{b_0}(0) = 0$, $F_{b_0}(\infty) = 1$ and $f_{b_0}(t) = dF_{b_0}(t)/dt$. Define $f_{b_1}(t)$ as the *pdf* and $F_{b_1}(t)$ the *cdf* of the random variable, $L'_b(k)$, time expended in State 1 by elements of representative portfolio of exchange lines.²⁰ It is assumed that the realizations of $L'_b(k)$ are independent and identically distributed. It follows that $F_{b_1}(0) = 0$, $F_{b_1}(\infty) = 1$ and $f_{b_1}(t) = dF_{b_1}(t)/dt$. Define $F_{b_0}^c(t)$ as the complement of $F_{b_0}(t)$. $F_{b_0}^c(t)$ is a non-decreasing function of t and $F_{b_0}^c(t) = 1 - F_{b_0}(t)$ and $F_{b_0}^c(0) = 1$. Define $F_{b_1}^c(t)$ as the complement of $F_{b_1}(t)$. $F_{b_1}^c(t)$ is a non-decreasing function of t and $F_{b_1}^c(t) = 1 - F_{b_1}(t)$ and $F_{b_1}^c(0) = 1$.

Drawing on renewal theory, for an equilibrium renewal process, the probability that a process will be in State 1 at time t given that it was in the same state at the origin is made up of two components. First, that a State 1 interval prevailing at $t = 0$ persists until time t . The *pdf* of this interval is $F_b^c(t)/\mu_{b_1}$. Second, there occurs a Type 0 event, at some time u , where $u < t$, followed by a Type 1 interval which persists for a period at least equal to $t - u$. Therefore

¹⁸The subscript/postscript b distinguishes the ADSL platform from the analogue platform studied in Chapter 5.

¹⁹For $k = 1, \dots, n$. Here k represents a state interval.

²⁰For $k = 1, \dots, n$.

we have that²¹

$$\rho_{b11}^e(t) = \int_t^\infty \frac{F_{b1}^c(u)}{\mu_{b1}} du + \int_0^t h_{b10}^e(u) F_{b1}^c(t-u) du \quad (6.14)$$

here h_{b10}^e is the renewal density of a Type 0 failure, given that the process starts at the origin in State 1. Taking the Laplace transform of Eqn. 6.14 above, we have that²²

$$\bar{\rho}_{b11}^e(s) = \frac{(u_{b1} - 1 + \bar{f}_{b1}(s))}{u_{b1}s^2} + h_{b10}^e \frac{(1 - \bar{f}_{b1}(s))}{s} \quad (6.15)$$

Drawing on B.11 in Appendix B and recognizing that for an equilibrium renewal process the Laplace transform of the *pdf* of $L'(0)$ is $1 - \bar{f}_{b1}(s)/u_1s$, where we start with a Type 1 interval and end with a Type 0 interval, we have that

$$\bar{h}_{b10}^e(s) = \frac{\bar{f}_{b0}(s)(1 - \bar{f}_{b1}(s))}{u_{b1}s(1 - \bar{f}_{b0}(s)\bar{f}_{b1}(s))} \quad (6.16)$$

Substituting Eqn. 6.16 in Eqn. 6.15 we have that

$$\bar{\rho}_{b11}^e(s) = \frac{1}{s} - \frac{(1 - \bar{f}_{b0}(s))(1 - \bar{f}_{b1}(s))}{u_{b1}s^2(1 - \bar{f}_{b0}(s)\bar{f}_{b1}(s))} \quad (6.17)$$

From Eqn. 6.17 the following holds

$$\lim_{t \rightarrow \infty} \rho_{b11}^e(t) = \frac{u_{b1}}{u_{b0} + u_{b1}} \quad (6.18)$$

Similarly, the following holds

$$\lim_{t \rightarrow \infty} \rho_{b01}^e(t) = \frac{u_{b1}}{u_{b0} + u_{b1}} \quad (6.19)$$

²¹Here μ_{b0} is the average length of time a representative portfolio of ADSL exchange lines expend in State 0. And μ_{b1} is the average length of time a representative portfolio of ADSL exchange lines expend in State 1. See Pham-Gia and Turkkan(1999).

²²Using B.14 and B.16 in Appendix B.

Therefore

$$\lim_{t \rightarrow \infty} \rho_{b1}^e(t) = \frac{u_{b1}}{u_{b0} + u_{b1}} \quad (6.20)$$

And

$$\lim_{t \rightarrow \infty} \rho_{b0}^e(t) = \frac{u_{b0}}{u_{b0} + u_{b1}} \quad (6.21)$$

For clarity of exposition, we let $\rho_{b1}^e(t) = \rho_b(t)$. Now the state of delivery points through space is defined on a probability space (Ω, ρ) where $\Omega = \{1, 0\}$ - the realizations $P_{bt}(i)$ is 1 with a probability of $\rho_b(t)$ and 0 with a probability of $1 - \rho_b(t)$. We can therefore define the process describing the state of lines through space, at any time t , as a Bernoulli process.²³

So far we have assumed that the moments of $f_{b0}(t)$ and $f_{b1}(t)$ are constant. However these parameters will change through time with corresponding changes in $\rho_b(t)$. One would expect that $\rho_b(t)$ increases if the utilization of an access platform is increased and the converse holds if the utilization of an access platform is decreased. The parameters of $f_{b0}(t)$ and $f_{b1}(t)$ cannot however be observed from the data in the public domain. The evolution of $\rho_b(t)$ can however be inferred from the data in the public domain and this evidence is used as a basis for the analysis in this chapter. We discuss the evolution of $\rho_b(t)$ in more detail in the next section.

6.4.2 Dynamic Intensity

Unlike the analogue platform where the data in the public domain provides evidence of the evolution of activation of delivery points, evidence from the ADSL platform in the public domain only provides a point estimate, where the level of inactivated lines is estimated at 14% - see Ofcom (2005a). Based this evidence and that in Section 5.4.2, the dynamics of activation in the ADSL

²³Similarly, through time we have it that the realizations $L_{bi}(t)$ is 1 with a probability of $\rho_b(t)$ and 0 with a probability of $1 - \rho_b(t)$.

platform, as with the dynamics of the analogue platform, can be assumed to take a noisy path. Therefore the evolution of $\rho_b(t)$ is described as an Ito process as follows²⁴

$$\frac{d\rho_b(t)}{\rho_b(t)} = \phi_{b\rho}dt + \sigma_{b\rho}dW(t)^{b\rho} \quad (6.22)$$

where $\phi_{b\rho}$ is the drift of the process, $\sigma_{b\rho}$ its volatility and $dW(t)^{b\rho}$, a Wiener term. Now $0 \leq \rho_b(t) \leq 1$. The expectation with respect to Eqn. 6.22, for $t > s$, is²⁵

$$E[\rho_b(t) | F_s] = \rho_b(s) \exp \left[\left(\phi_{b\rho} - \frac{1}{2}\sigma_{b\rho}^2 \right) (t - s) \right] \quad (6.23)$$

and the corresponding variance is

$$Var[\rho_b(t) | F_s] = \sigma_{b\rho}^2 (t - s) \quad (6.24)$$

If it is assumed that the risk associated with $\rho_b(t)$ is not incorporated in $S_b(t)$, by Girsanov's Theorem, the Randon-Nikodym derivative for the change of measure of the P -Brownian motion is

$$L_{b\rho}(t) = \exp \left[- \int_0^t \lambda_2(s) dW(s) - \frac{1}{2} \int_0^t (\lambda_2(s))^2 ds \right] \quad (6.25)$$

where λ_2 is the price of the risk of default. Using Girsanov's Theorem, the relationship between the P and Q -Wiener processes is as follows

$$dW(t)^{b\rho} = d\widetilde{W}(t)^{b\rho} - \lambda_2 dt \quad (6.26)$$

²⁴The subscript/postscript b distinguishes the ADSL platform from the analogue platform studied in Chapter 5 and the subscript/postscript ρ represents the process defining line activation.

²⁵The constraint $0 \leq \rho_b(t) \leq 1$ is important. Eqn. 6.24 by itself does not however impose this constraint. For our purposes given $\rho_b(0)$, the volatility of the process $\sigma_{b\rho}$ and the window under consideration [$t = 0, t = 12$], the constraint is unlikely to be violated. If it was likely that the constraint would be violated then a modification of Eqn. 6.24 would be called for.

where $d\widetilde{W}(t)^{b\rho}$ is a Q -Weiner process. Using Eqn. 6.26 the Q -dynamics of the $\rho_b(t)$ -process is represented as follows

$$\begin{aligned} \frac{d\rho_b(t)}{\rho_b(t)} &= \phi_{b\rho}dt + \sigma_{b\rho}(d\widetilde{W}(t)^{b\rho} - \lambda_2dt) \\ &= (\phi_{b\rho} - \sigma_{b\rho}\lambda_2)dt + \sigma_{b\rho}d\widetilde{W}(t)^{b\rho} \end{aligned} \quad (6.27)$$

Now that $\rho_b(t)$ evolves as a martingale, the following must necessarily hold²⁶

$$\phi_{b\rho}(t) - \sigma_{b\rho}\lambda_2 = 0 \quad (6.28)$$

The Matlab Code for simulating $\rho_b(t)$ under both objective and risk-neutral measures is in Appendix D (see M-File II).

6.5 Access Layer and Conveyance

As with the analogue network, the FL-LRIC rental charge for the right of access to the Subscriber Access Network is charged per unit time. This charge is the sum of the geographical average element cost of each of the elements comprising the Access Network. This is therefore a charge for wholesale access from the NTE to the DSLAM. Each of these elements has a regulated access price chargeable per unit time and these remain fixed for a regulatory lag. The strike price for the right of access per exchange line per unit time can be represented as follows

$$K_b(t) = \sum_{j=1}^n B_{bj}(t) \quad (6.29)$$

²⁶The model above assumes that $\sigma_{b\rho}$ is a constant. Evidence from data points at more frequent intervals and from a longer time series may suggest otherwise. The model above should therefore be seen as a first order model which could be developed further to accommodate any stochastic behaviour of $\sigma_{b\rho}$.

where B_{bi} is defined as the regulated price of access of the i^{th} access component in the the Subscriber Access Network. The FL-LRIC access price for the various elements of the Access Network are published in BT's regulatory accounts. The aggregate regulated access charges are published in Section 44 of BT's *Wholesale Broadband Services Price List*. With respect to conveyance, we consider Customer Sited Handover²⁷ where a third-party access seeker rents end-to-end connectivity. The average price of such connectivity for singleton lines is

$$U_b(t) = \sum_{i=1}^n D_{bi}(t) * E_{bi}(t) + R_b(t) \quad (6.30)$$

where $D_{bi}(t) * E_{bi}(t)$, for $i = 1$ to 4, represents the average unit cost of a virtual path for backhaul and conveyance in the core network, and $R_b(t)$ the average unit price of a virtual path in the Customer Access Link. Here D_{b1} represents price of a handover VP; D_{b2} , local VP; D_{b3} , regional VP; and D_{b4} , national VP. We obtain these costs from BT's *Wholesale Broadband Services Price List*. Now E_{bi} represents the respective proportion of handover, local, regional and national VPs in a representative portfolio of exchange lines. We find that these are 10%, 70%, 10% and 10%, respectively.²⁸ A contention ratio of 50:1 is assumed - see Ofcom (2004a) for the basis of this assumption. The data used for the computation of conveyance charges is in Tables E.7, E.8, E.9, E.11 and E.12 in Appendix E.

6.6 Model Calibration

We observe sample data $S_b^* = \{S_b(t_0)^*, S_b(t_1)^* \dots S_b(t_n)^*\}$. We use the Maximum Likelihood Estimation to solve for $\theta_{bs} = (\gamma_{bs}, \sigma_{bs} \text{ and } \alpha_{bs})$ such that

²⁷Customer Sited Handover is differentiated from In Span Handover in that the former corresponds to end-to-end connectivity and handover in respect of the latter service is at a distant switch.

²⁸See Ofcom (2004a)

the likelihood of observing the sample data is maximized. This is achieved by maximizing the following likelihood function

$$\wedge(\theta_{bs}) = \prod_{i=0}^n f(S_b(t)^*; \theta_{bs}) \quad (6.31)$$

Here $f(S_b(t)^*)$ is a density function. To ease the computation, we convert Eqn. 6.31 above into a log-likelihood function $\ln[\wedge(\theta_{bs})] = L(\theta_{bs})$. Now $L(\theta_{bs})$ can be written as follows

$$\ln[\wedge(\theta_{bs})] = L(\theta_{bs}) = \ln \left[\prod_{i=0}^n f(S_b(t)^*; \theta_{bs}) \right] = \sum_{i=0}^n \ln[f(S_b(t)^*; \theta_{bs})] \quad (6.32)$$

Given $n + 1$ observations $S_b(t_0)^*, S_b(t_1)^* \dots S_b(t_n)^*$, knowing that its mean and variance are as represented in Eqn. 6.4 and Eqn. 6.5, the conditional probability of the occurrence of $S_b(t_i)^*$ given $S_b(t_{i-1})^*$, is

$$f(S_b(t_i)^*; \gamma_{bs}, \sigma_{bs}, \alpha_{bs}) = (2\pi)^{-\frac{1}{2}} \left(\frac{\sigma_{bs}^2}{2\gamma_{bs}} (1 - e^{-2\gamma_{bs}(t_i - t_{i-1})}) \right)^{-\frac{1}{2}} * \exp \left(\frac{-(S_b(t_i)^* - \alpha_{bs} - (S_b(t_{i-1})^* - \alpha_{bs})e^{-\gamma_{bs}(t_i - t_{i-1})})^2}{2\frac{\sigma_{bs}^2}{2\gamma_{bs}}(1 - e^{-2\gamma_{bs}(t_i - t_{i-1})})} \right) \quad (6.33)$$

Using the result in Eqn. 6.33, we can write the log-likelihood function as

$$L(S_b(t)^*; \gamma_{bs}, \sigma_{bs}, \alpha_{bs}) = -\frac{n}{2} \log \left(\frac{\sigma_{bs}^2}{2\gamma_{bs}} \right) - \frac{1}{2} \sum_{i=1}^n \log(1 - e^{-2\gamma_{bs}(t_i - t_{i-1})}) - \frac{\gamma_{bs}}{\sigma_{bs}^2} \sum_{i=1}^n \left(\frac{(S_b(t_i)^* - \alpha_{bs} - (S_b(t_{i-1})^* - \alpha_{bs})e^{-\gamma_{bs}(t_i - t_{i-1})})^2}{(1 - e^{-2\gamma_{bs}(t_i - t_{i-1})})} \right) \quad (6.34)$$

The Matlab Code for the Maximum Likelihood Estimates based on Eqn. 6.34 is in Appendix D (see M-File IV).

6.7 Valuation

The theoretical framework for valuing a contingent claim on $S_b(t)$ follows from the theory set out in Section 5.7. Now we know that the price of a forward is equivalent to the price of the spot under risk-neutral expectations i.e. $E^Q[S_b(t) | F_s] = F(S_b(t); s, t)$. Following from Eqn. 6.12 and Eqn. 6.13, given the properties of a lognormal distribution, the expected value of the spot under risk-neutral assumptions is²⁹

$$E^Q[S_b(t) | F_s] = F(S_b(t); s, t) = \exp \left[E[S_b(t)^* | F_s] + \frac{1}{2} \text{Var}[S_b(t)^* | F_s] \right] \quad (6.35)$$

Therefore³⁰

$$E^Q[S_b(t) | F_s] = \exp \left[S_b(s)^* e^{-\gamma_{bs}(t-s)} + \alpha_{bs}^* (1 - e^{-\gamma_{bs}(t-s)}) + \frac{\sigma_{bs}^2}{4\gamma_{bs}} (1 - e^{-\gamma_{bs}(t-s)}) \right] \quad (6.36)$$

Knowing that $F(S_b(t); s, t) = E^Q[S_b(t) | F_s]$, Eqn. 6.36 can alternatively be written as

$$\ln F(S_b(t); s, t) = S_b(s)^* e^{-\gamma_{bs}(t-s)} + \alpha_{bs}^* (1 - e^{-\gamma_{bs}(t-s)}) + \frac{\sigma_{bs}^2}{4\gamma_{bs}} (1 - e^{-\gamma_{bs}(t-s)}) \quad (6.37)$$

If we take $S_b(t)$ and $\rho_b(t)$ to be separate and independent processes in the short-run,³¹ then knowing that a rational access seeker will align entry and exit, and negotiate contracts such that for any time interval $F(S_b(t); t, t) > K_b$, the

²⁹From the properties of a lognormal distribution $F(s, t) = E^Q[S(t)^* | F_s] = e^{\nu_1 + \frac{1}{2}\nu_2}$ where ν_1 is the mean of the log of the spot price and ν_2 is the variance of the log of the spot price.

³⁰From the evidence in Chapter 8, the correlation between $Y_b(t)$ and $\rho_b(t)$ is spurious, at least in the short run. Based on this evidence any correlation between the noise terms of the two processes, if any, is not investigated further.

³¹Where the risk associated with $\rho_b(t)$ is incorporated in $S_b(t)$.

value of a contingent claim on the $S_b(t)$ process incorporating the stochastic intensity of line activation, is

$$C(s, F(S_b(t)); t, K_b) = [E[F(S_b(t); t, t) - K_b, 0]^+ * E[\rho_b(t)]] e^{-r(t-s)} \quad (6.38)$$

where $E[\rho_b(t)]$ is the intensity of exchange line activation under objective measures. Eqn. 6.38 assumes that the risk associated with $\rho_b(t)$ is incorporated in $S_b(t)$, i.e. Scenario I. If we assume that in fact the risk associated with inactivation is not incorporated in $S_b(t)$, i.e. Scenario II, then the value of a contingent claim on $S_b(t)$ is

$$C(s, F(S_b(t)); t, K_b) = [E[F(S_b(t); t, t) - K_b, 0]^+ * E^Q[\rho_b(t)]] e^{-r(t-s)} \quad (6.39)$$

where $E^Q[\rho_b(t)]$ is the intensity of exchange line inactivation under risk-neutral expectations. The alternative assumptions underlying Scenarios I and II are deemed to be the two most plausible ways of investigating the questions that are the subject of this thesis. A third contender is not obvious. The Matlab code corresponding to Eqn. 6.38 is in Appendix D (see M-File III). Analytical solutions corresponding to Eqn. 6.38 and Eqn. 6.39 are developed in Chapter 7. The results and discussion are in Chapter 8.

6.8 Summary

Mandatory capacity access raises the question of the value of the differentiated abilities of the access provider and access seekers to adapt to the stochastic dynamics of downstream value at the level of the delivery points - more specifically, their differentiated abilities to adapt to the migration of the upside and the downside between the delivery points in a ADSL network. This chapter developed a framework for valuing the flexibility of adapting to downstream value, and tested the neutrality of FL-LRIC as an approach for pricing capac-

ity access, based on evidence from the ADSL platform. This included evidence from the 8 mbit/s subscriber access market covering the period January 2000 to December 2008 in the UK. As with the analysis of the analogue voice capacity access market, contingent claim pricing theory is used as a theoretical framework. This pricing theory has been used because of its capacity to conceptualize and quantify the value of flexibility. A numerical method, Monte Carlo simulation, is used because its capacity to value complex derivatives defined by multi-dimensional stochastic processes. Maximum Likelihood Estimation is used to calibrate the stochastic differential equations describing downstream value and the value of the underlying contingent claims are estimated using martingale pricing.

We have drawn on the intensity-based approach to contingent claim valuation. This approach takes into account the stochastic dynamics of the value of the underlying asset and the dynamics of default. Default is conceived as being triggered by an exogenous process which is either fully or partially independent of the value of the underlying asset. The price of market risk and the price of the risk of default are used as the handles that define the martingale equivalents of the process that generates value.

In summary, this chapter provides an approach for valuing contingent claims in the ADSL capacity access platform. This is approach together with the evidence from the residential analogue market in the UK form the basis of the numerical analysis that test the symmetry or otherwise of FL-LRIC. Chapter 7 develops closed-form analytical solutions based on the evidence in this chapter and Chapter 8 presents the results.

Chapter 7

ACCESS PRICING: OPTION-THEORETIC

ANALYTICAL GENERALIZATIONS

7.1 Introduction

Chapters 5 and 6 of this thesis investigate whether FL-LRIC, as a method of pricing access in telecommunication capacity access markets is distortionary, based on UK evidence from the analogue and ADSL capacity platforms. A numerical method, Monte-Carlo simulation, is used for the analysis in the two chapters because of its versatility in computing high-dimensional integrals and valuing complex derivatives defined by multi-dimensional stochastic processes. This chapter develops closed-form analytical solutions to price the value of third-party flexibility to adapt to downstream stochastic processes in the analogue and ADSL capacity markets. These solutions are founded on the properties of the evolution of net average downstream value of an activated exchange line, including its drift and volatility; intensity of activation, including its drift and volatility; the price of access to the Subscriber Network; the price of market risk; and the price of the risk of default. More generally, these solutions, first, provide a basis for checking the results from the numerical methods in Chapters 5 and 6. Second, these solutions generalize the results and provide an option-theoretic framework for pricing access where third parties have the leverage of adapting to downstream stochastic value.

Martingale pricing principles are the basis of the analysis in this chapter wherein the value of a contingent claim, given arbitrage arguments, is equivalent to the pay-offs of the claim under risk-neutral probabilities, discounted at the risk-free rate. We use an intensity-based approach to develop the analytical solutions. Here, the intensity parameter captures the effect of the stochastic

intensity of exchange line activation. This approach therefore takes into account the stochastic dynamics of the primary value of the underlying asset and the dynamics of activation. Activation is conceived as being triggered by an exogenous process which is either fully or partially independent of the value of the underlying asset. The price of market risk and the price of the risk of default are used as the handles that define the martingale equivalents of the process that generates value. The case of contingent claim analysis in telecommunication capacity access markets presents a special case where the risk of inactivation is driven by a two-state on-off process. Section 7.2 focuses on the analogue platform and Section 7.3, the ADSL platform.

7.2 Analogue : Closed-form Analytical Generalizations

The proposition in Eqn. 7.1 depicts the value of a call on downstream value. Now Eqn. 7.2 and Eqn. 7.3 provide the underlying lemmas and Eqn. 7.4 to Eqn. 7.22, prove the proposition. Intuitively, the closed-form analytical solution captures the value of exposure to the upside and not the downside of downstream value, from an option-theoretic standpoint. Here such downstream value is described by the evolution of the net average downstream value of an activated exchange line, including its drift and volatility; intensity of line activation, including its drift and volatility; and the price of access to the Subscriber Network. The generalization in Eqn. 7.1 provides a basis to price the protection from the downside arising from market and default risk, and is based on the market price of risk and the price of default risk. The proposition is stated as follows:

$$C(F(S_a(t)), K_a, s, t) = \left\{ F(S_a(t); s, t) N \left\{ \frac{\ln\left(\frac{F(S_a(t); s, t)}{K_a}\right) + \frac{\sigma_{af}^2}{2}}{\sigma_{af}} \right\} - K_a N \left\{ \frac{\ln\left(\frac{F(S_a(t); s, t)}{K_a}\right) - \frac{\sigma_{af}^2}{2}}{\sigma_{af}} \right\} \right\} * E[\rho_a(t)] * e^{-r(t-s)} \quad (7.1)$$

where

$$F(S_a(t); s, t) = \exp \left[(S_a(s)^* - \alpha_{as}^*(s))e^{-\gamma_{as}(t-s)} + \alpha_{as}^*(t) + \frac{\sigma_{as}^2}{4\gamma_{as}}(1 - e^{-\gamma_{as}(t-s)}) \right]$$

and where

$$\alpha_{as}^*(t) = \beta_s + \xi_s(t) + \eta_s \sin(\omega_s t + v_s) - \frac{\lambda_1 \sigma_{as}}{\gamma_{as}}$$

In the foregoing $S_a(t)$ represents the evolution of the net average downstream value of an activated exchange line¹, σ_{as} the volatility of the SDE describing the evolution of $S_a(t)^*$, $\alpha_{as}^*(t)$ the risk-neutral level around which $S_a(t)^*$ oscillates, σ_{af} the standard deviation of $S_a(t)^*$, $\rho_a(t)$ the intensity of exchange line activation, $\sigma_{a\rho}$ the volatility of activation, $\phi_{a\rho}$ the drift of activation, K_a the price of access to the Subscriber Network², λ_1 the price of market risk and λ_2 the price of the risk of default. Here the parameters of the trigonometric function, β_s , ξ_s , η_s , ω_s and v_s , are constants. We know from Section 5.7 that, under risk-neutral expectations, $S_a(t)^* \sim N(\mu_{as}(t), \sigma_{af}^2)$ where

$$\mu_{as}(t) = (S_a(s)^* - \alpha_{as}^*(s))e^{-\gamma_{as}(t-s)} + \alpha_{as}^*(t) \quad (7.2)$$

And where

$$\sigma_{af}^2 = \frac{\sigma_{as}^2}{2\gamma_{as}}(1 - e^{-2\gamma_{as}(t-s)}) \quad (7.3)$$

The proofs of the lemmas in Eqn. 7.2 and Eqn. 7.3 can be inferred from Appendix A. Letting $u = \ln F(S_a(t); t, t)$, we have that downstream value on the risk-neutral process, given an activated state, is

¹Here $S_a(t)^* = \ln S_a(t)$.

²The index t is dropped for clarity of exposition.

$$V(S_a(t); s, t) = \int_{-\infty}^{+\infty} (F(S_a(t); t, t) - K_a) \frac{1}{\sigma_{af}\sqrt{2\pi}} \exp\left\{-\frac{1}{2} \left[\frac{u - \mu_{as}(t)}{\sigma_{af}}\right]^2\right\} du \quad (7.4)$$

Knowing that a rational access seeker will align entry and exit and negotiate contractual terms such that $F(S_a(t); t, t) > K_a$, the risk-neutral value accruing to an access seeker is therefore

$$\begin{aligned} E[(F(S_a(t); t, t) - K_a), 0]^+ &= \\ &= \int_{\ln K_a}^{+\infty} (F(S_a(t); t, t) - K_a) \frac{1}{\sigma_{af}\sqrt{2\pi}} \exp\left\{-\frac{1}{2} \left[\frac{u - \mu_{as}(t)}{\sigma_{af}}\right]^2\right\} du \\ &= \int_{\ln K_a}^{+\infty} F(S_a(t); t, t) \frac{1}{\sigma_{af}\sqrt{2\pi}} \exp\left\{-\frac{1}{2} \left[\frac{u - \mu_{as}(t)}{\sigma_{af}}\right]^2\right\} du - \\ &\quad \int_{\ln K_a}^{\infty} K_a \frac{1}{\sigma_{af}\sqrt{2\pi}} \exp\left\{-\frac{1}{2} \left[\frac{u - \mu_{as}(t)}{\sigma_{af}}\right]^2\right\} du \end{aligned} \quad (7.5)$$

From the first part of Eqn. 7.5 we have that

$$\begin{aligned} &= \int_{\ln K_a}^{+\infty} F(S_a(t); t, t) \frac{1}{\sigma_{af}\sqrt{2\pi}} \exp\left\{-\frac{1}{2} \left[\frac{u - \mu_{as}(t)}{\sigma_{af}}\right]^2\right\} du \\ &= \int_{\ln K_a}^{+\infty} \frac{1}{\sigma_{af}\sqrt{2\pi}} \exp\left\{\ln F(S_a(t); t, t) - \frac{1}{2} \left[\frac{u - \mu_{as}(t)}{\sigma_{af}}\right]^2\right\} du \end{aligned} \quad (7.6)$$

Or

$$\int_{\ln K_a}^{+\infty} \frac{1}{\sigma_{af}\sqrt{2\pi}} \exp\left\{u - \frac{1}{2} \left[\frac{u - \mu_{as}(t)}{\sigma_{af}}\right]^2\right\} du \quad (7.7)$$

From Eqn. 7.7, the term in the first pair of brackets can be written as follows

$$\begin{aligned}
& u - \frac{(u^2 - 2\mu_{as}(t)u + \mu_{as}(t)^2)}{2\sigma_{af}^2} \\
&= \frac{2\sigma_{af}^2 u - u^2 + 2\mu_{as}(t)u - \mu_{as}(t)^2}{2\sigma_{af}^2} \\
&= \frac{1}{2\sigma_{af}^2} (2\sigma_{af}^2 u - u^2 + 2\mu_{as}(t)u) - \frac{\mu_{as}(t)^2}{2\sigma_{af}^2} \\
&= -\frac{1}{2\sigma_{af}^2} (u^2 - 2\sigma_{af}^2 u - 2\mu_{as}(t)u) - \frac{\mu_{as}(t)^2}{2\sigma_{af}^2} \\
&= -\frac{1}{2\sigma_{af}^2} (u^2 - 2u(\sigma_{af}^2 + \mu_{as}(t))) - \frac{\mu_{as}(t)^2}{2\sigma_{af}^2} \tag{7.8}
\end{aligned}$$

Let $\varphi = (\sigma_{af}^2 + \mu_{as}(t))$. Now therefore Eqn. 7.8 can be written as

$$-\frac{1}{2\sigma_{af}^2} (u^2 - 2u\varphi) - \frac{\mu_{as}(t)^2}{2\sigma_{af}^2} \tag{7.9}$$

Completing the square with respect to Eqn. 7.9, we have

$$-\frac{1}{2\sigma_{af}^2} ((u - \varphi)^2 - \varphi^2) - \frac{\mu_{as}(t)^2}{2\sigma_{af}^2} \tag{7.10}$$

Substituting $(\sigma_{af}^2 + \mu_{as}(t))$ for φ in Eqn. 7.10, we have

$$\begin{aligned}
& -\frac{1}{2\sigma_{af}^2} ((u - (\sigma_{af}^2 + \mu_{as}(t)))^2 - (\sigma_{af}^2 + \mu_{as}(t))^2) - \frac{\mu_{as}(t)^2}{2\sigma_{af}^2} \\
&= -\frac{1}{2\sigma_{af}^2} (u - (\sigma_{af}^2 + \mu_{as}(t)))^2 + \frac{(\sigma_{af}^2 + \mu_{as}(t))^2 - \mu_{as}(t)^2}{2\sigma_{af}^2} \\
&= -\frac{1}{2\sigma_{af}^2} (u - (\sigma_{af}^2 + \mu_{as}(t)))^2 + \frac{(\sigma_{af}^4 + 2\sigma_{af}^2\mu_{as}(t) + \mu_{as}(t)^2 - \mu_{as}(t)^2)}{2\sigma_{af}^2}
\end{aligned}$$

$$= -\frac{1}{2} \left(\frac{u - (\sigma_{af}^2 + \mu_{as}(t))}{\sigma_{af}} \right)^2 + \frac{\sigma_{af}^2}{2} + \mu_{as}(t) \quad (7.11)$$

Re-arranging Eqn. 7.11, we have

$$\mu_{as}(t) + \frac{\sigma_{af}^2}{2} - \frac{1}{2} \left(\frac{u - (\mu_{as}(t) + \sigma_{af}^2)}{\sigma_{af}} \right)^2 \quad (7.12)$$

Substituting Eqn. 7.12 in Eqn. 7.7, we have

$$\int_{\ln K_a}^{+\infty} \frac{1}{\sigma_{af} \sqrt{2\pi}} \exp \left\{ \mu_{as}(t) + \frac{\sigma_{af}^2}{2} - \frac{1}{2} \left[\frac{u - (\mu_{as}(t) + \sigma_{af}^2)}{\sigma_{af}} \right]^2 \right\} du \quad (7.13)$$

Eqn. 7.13 can be written as follows

$$\exp(\mu_{as}(t) + \frac{\sigma_{af}^2}{2}) \int_{\ln K_a}^{+\infty} \frac{1}{\sigma_{af} \sqrt{2\pi}} \exp \left\{ -\frac{1}{2} \left[\frac{u - (\mu_{as}(t) + \frac{\sigma_{af}^2}{2}) - \frac{\sigma_{af}^2}{2}}{\sigma_{af}} \right]^2 \right\} du \quad (7.14)$$

Knowing that from the lognormal properties of $S_a(t)^*$ that $\ln F(S_a(t); s, t) = \mu_{as}(t) + \frac{\sigma_{af}^2}{2}$, Eqn. 7.14 can be represented as follows

$$F(S_a(t); s, t) \int_{\ln K_a}^{+\infty} \frac{1}{\sigma_{af} \sqrt{2\pi}} \exp \left\{ -\frac{1}{2} \left[\frac{u - \ln F(S_a(t); s, t) - \frac{\sigma_{af}^2}{2}}{\sigma_{af}} \right]^2 \right\} du \quad (7.15)$$

Since the integration in Eqn. 7.15 is from $\ln K_a$, we have

$$\begin{aligned}
& F(S_a(t); s, t) \left\{ 1 - N \left[\frac{\ln\left(\frac{K_a}{F(S_a(t); s, t)}\right) - \frac{\sigma_{af}^2}{2}}{\sigma_{af}} \right] \right\} \\
& = F(S_a(t); s, t) \left\{ N \left[\frac{\ln\left(\frac{F(S_a(t); s, t)}{K_a}\right) + \frac{\sigma_{af}^2}{2}}{\sigma_{af}} \right] \right\}
\end{aligned} \tag{7.16}$$

here $N(\cdot)$ represents a cumulative distribution function for the normal distribution. From the second part of Eqn. 7.5 we have

$$\int_{\ln K_a}^{+\infty} \frac{1}{\sigma_{af} \sqrt{2\pi}} \exp \left\{ -\frac{1}{2} \left[\frac{u - \mu_{as}(t)}{\sigma_{af}} \right]^2 \right\} du \tag{7.17}$$

Now $(\ln K_a - \mu_{as}(t))/\sigma_{af}$ can be written as

$$\begin{aligned}
& \frac{\ln K_a - \left(\mu_{as}(t) + \frac{\sigma_{af}^2}{2} \right) + \frac{\sigma_{af}^2}{2}}{\sigma_{af}} \\
& = \frac{\left(\ln K_a - \ln F(S_a(t); s, t) + \frac{\sigma_{af}^2}{2} \right)}{\sigma_{af}}
\end{aligned} \tag{7.18}$$

Therefore Eqn. 7.17 can be written as follows

$$\begin{aligned}
& 1 - N \left\{ \frac{\ln \left(\frac{K_a}{F(S_a(t); s, t)} \right) + \frac{\sigma_{af}^2}{2}}{\sigma_{af}} \right\} \\
& = N \left\{ \frac{\ln \left(\frac{F(S_a(t); s, t)}{K_a} \right) - \frac{\sigma_{af}^2}{2}}{\sigma_{af}} \right\}
\end{aligned} \tag{7.19}$$

Inferring from Eqn. 7.5 and combining Eqn. 7.16 and Eqn. 7.19, we have that

$$F(S_a(t); s, t)N \left\{ \frac{\ln\left(\frac{F(S_a(t); s, t)}{K_a}\right) + \frac{\sigma_{af}^2}{2}}{\sigma_{af}} \right\} - K_a N \left\{ \frac{\ln\left(\frac{F(S_a(t); s, t)}{K_a}\right) - \frac{\sigma_{af}^2}{2}}{\sigma_{af}} \right\} \quad (7.20)$$

Following from Eqn. 5.62, and incorporating the effect of exchange line activation, if it is assumed that the risk associated with $\rho_a(t)$ is incorporated in $S_a(t)$, we have³

$$\begin{aligned} C(F(S_a(t)), K_a, s, t) = \\ \left\{ F(S_a(t); s, t)N \left\{ \frac{\ln\left(\frac{F(S_a(t); s, t)}{K_a}\right) + \frac{\sigma_{af}^2}{2}}{\sigma_{af}} \right\} - K_a N \left\{ \frac{\ln\left(\frac{F(S_a(t); s, t)}{K_a}\right) - \frac{\sigma_{af}^2}{2}}{\sigma_{af}} \right\} \right\} * \\ E[\rho_a(t)] * e^{-r(t-s)} \end{aligned} \quad (7.21)$$

where⁴

$$F(S_a(t); s, t) = \exp \left[(S_a(s)^* - \alpha_{as}^*(s))e^{-\gamma_{as}(t-s)} + \alpha_{as}^*(t) + \frac{\sigma_{as}^2}{4\gamma_{as}}(1 - e^{-\gamma_{as}(t-s)}) \right]$$

and where from Eqn. 5.34, the dynamics of $\rho_a(t)$ under objective measures is⁵

$$E[\rho_a(t) | F_s] = \rho_a(s) \exp \left[(\phi_{a\rho} - \frac{1}{2}\sigma_{a\rho}^2)(t-s) \right] \quad (7.22)$$

³That is Scenario I.

⁴From the properties of the lognormal distribution.

⁵If it is assumed that the risk associated with $\rho_a(t)$ is not incorporated $S_a(t)$, then $E^Q[\rho_a(t) | F_s]$ applies.

7.3 ADSL : Closed-form Analytical Generalizations

Section 7.2 developed analytical solutions of the value of the flexibility of adapting to downstream value in an analogue platform. This section develops a closed-form solution of the value of such flexibility with respect to the ADSL platform. This solution is founded on the properties of the evolution of net average downstream value of an activated exchange line, including its drift and volatility; intensity of exchange line activation, including its drift and volatility; the price of access to the Subscriber Network; the price of market risk; and the price of the risk of default. Unlike the analogue platform, downstream value in the ADSL platform, for the service studied here, does not depend on traffic. Further unlike the analogue platform, downstream value does not have seasonal variations. The proposition in Eqn. 7.23 depicts the value of a call on downstream value. Now Eqn. 7.24 and Eqn. 7.25 provide the underlying lemmas and Eqn. 7.26 to Eqn. 7.39, prove the proposition. The proposition is stated as follows:

$$\begin{aligned}
 & C(F(S_b(t); s, t), K_b, s, t) = \\
 & \left\{ F(S_b(t); s, t) N \left\{ \frac{\ln\left(\frac{F(S_b(t); s, t)}{K_b}\right) + \frac{\sigma_{bf}^2}{2}}{\sigma_{bf}} \right\} - K_b N \left\{ \frac{\ln\left(\frac{F(S_b(t); s, t)}{K_b}\right) - \frac{\sigma_{bf}^2}{2}}{\sigma_{bf}} \right\} \right\} * \\
 & E[\rho_b(t)] * e^{-r(t-s)}
 \end{aligned} \tag{7.23}$$

where

$$\begin{aligned}
 & F(S_b(t); s, t) = \\
 & \exp \left[S_b(s) e^{-\gamma_{bs}(t-s)} + \alpha_{bs}^* (1 - e^{-\gamma_{bs}(t-s)}) + \frac{\sigma_{bs}^2}{4\gamma_{bs}} (1 - e^{-\gamma_{bs}(t-s)}) \right]
 \end{aligned}$$

and where

$$\alpha_{bs}^* = \alpha_{bs} - \frac{\lambda_1 \sigma_{bs}}{\gamma_{bs}}$$

In the foregoing, $S_b(t)$ represents the evolution of net average downstream value of an exchange line⁶, K_b the price of access to the Subscriber Network⁷, σ_{bs} the volatility of the SDE describing the evolution of $S_b(t)^*$, σ_{bf} the standard deviation of $S_b(t)^*$, $\rho_b(t)$ the intensity of exchange line inactivation, $\sigma_{b\rho}$ the volatility of activation, $\phi_{b\rho}$ the drift of the activation, α_{bs}^* is the risk-neutral level around which $S_b(t)^*$ oscillates, λ_1 is the price of market risk and λ_2 the price of the risk of default. We know from Section 6.3 that $S_b(t)^* \sim N(\mu_{bs}, \sigma_{bf}^2)$ where

$$\mu_{bs} = S_b(s)^* e^{-\gamma_{bs}(t-s)} + \alpha_{bs}^* (1 - e^{-\gamma_{bs}(t-s)}) \quad (7.24)$$

And

$$\sigma_{bf}^2 = \frac{\sigma_{bs}^2}{2\gamma_{bs}} (1 - e^{-2\gamma_{bs}(t-s)}) \quad (7.25)$$

The proofs of the lemmas in Eqn. 7.24 and Eqn. 7.25 can be inferred from Appendix A. Letting $u = \ln F(S_b(t); t, t)$, we have that downstream value on the risk-neutral process, in an activated state, is

$$V(S_b(t); s, t) = \int_{-\infty}^{+\infty} (F(S_b(t); t, t) - K_b) \frac{1}{\sigma_{bf} \sqrt{2\pi}} \exp \left\{ -\frac{1}{2} \left[\frac{u - \mu_{bs}}{\sigma_{bf}} \right]^2 \right\} du \quad (7.26)$$

Knowing that a rational access seeker will align entry and exit and negotiate contractual terms such that $F(S_b(t); t, t) > K$, the risk-neutral value accruing to an access seeker is therefore

⁶Here $S_b(t)^* = \ln S_b(t)$

⁷The index t is dropped for clarity of exposition.

$$\begin{aligned}
& E[(F(S_b(t); s, t) - K_b), 0]^+ = \\
& \int_{\ln K_b}^{+\infty} (F(S_b(t); t, t) - K_b) \frac{1}{\sigma_{bf}\sqrt{2\pi}} \exp\left\{-\frac{1}{2}\left[\frac{u-\mu_{bs}}{\sigma_{bf}}\right]^2\right\} du \\
& = \int_{\ln K_b}^{+\infty} F(S_b(t); t, t) \frac{1}{\sigma_{bf}\sqrt{2\pi}} \exp\left\{-\frac{1}{2}\left[\frac{u-\mu_{bs}}{\sigma_{bf}}\right]^2\right\} du - \\
& \quad \int_{\ln K_b}^{\infty} K_b \frac{1}{\sigma_{bf}\sqrt{2\pi}} \exp\left\{-\frac{1}{2}\left[\frac{u-\mu_{bs}}{\sigma_{bf}}\right]^2\right\} du
\end{aligned} \tag{7.27}$$

From the first part of Eqn. 7.27 we have that

$$\begin{aligned}
& \int_{\ln K_b}^{+\infty} F(S_b(t); t, t) \frac{1}{\sigma_{bf}\sqrt{2\pi}} \exp\left\{-\frac{1}{2}\left[\frac{u-\mu_{bs}}{\sigma_{bf}}\right]^2\right\} du \\
& = \int_{\ln K_b}^{+\infty} \frac{1}{\sigma_{bf}\sqrt{2\pi}} \exp\left\{\ln F(S_b(t); t, t) - \frac{1}{2}\left[\frac{u-\mu_{bs}}{\sigma_{bf}}\right]^2\right\} du
\end{aligned} \tag{7.28}$$

Or

$$\int_{\ln K_b}^{+\infty} \frac{1}{\sigma_{bf}\sqrt{2\pi}} \exp\left\{u - \frac{1}{2}\left[\frac{u-\mu_{bs}}{\sigma_{bf}}\right]^2\right\} du \tag{7.29}$$

Eqn. 7.29 can be written as follows

$$\int_{\ln K_b}^{+\infty} \frac{1}{\sigma_{bf}\sqrt{2\pi}} \exp\left\{\mu_{bs} + \frac{\sigma_{bf}^2}{2} - \frac{1}{2}\left[\frac{u - (\mu_{bs} + \sigma_{bf}^2)}{\sigma_{bf}}\right]^2\right\} du \tag{7.30}$$

Eqn. 7.30 can be written as follows

$$\exp\left(\mu_{bs} + \frac{\sigma_{bf}^2}{2}\right) \int_{\ln K_b}^{+\infty} \frac{1}{\sigma_{bf}\sqrt{2\pi}} \exp\left\{-\frac{1}{2}\left[\frac{u - \left(\mu_{bs} + \frac{\sigma_{bf}^2}{2}\right) - \frac{\sigma_{bf}^2}{2}}{\sigma_{bf}}\right]^2\right\} du \quad (7.31)$$

Knowing that $\ln F(S_b(t); s, t) = \mu_{bs} + \frac{\sigma_{bf}^2}{2}$, we have from Eqn. 7.31 that

$$F(S_b(t); s, t) \int_{\ln K_b}^{+\infty} \frac{1}{\sigma_{bf}\sqrt{2\pi}} \exp\left\{-\frac{1}{2}\left[\frac{u - \ln F(S_b(t); s, t) - \frac{\sigma_{bf}^2}{2}}{\sigma_{bf}}\right]^2\right\} du \quad (7.32)$$

Since the integration in Eqn. 7.32 is from $\ln K_b$, we have

$$\begin{aligned} & F(S_b(t); s, t) \left\{ 1 - N \left[\frac{\ln \left(\frac{K_b}{F(S_b(t); s, t)} \right) - \frac{\sigma_{bf}^2}{2}}{\sigma_{bf}} \right] \right\} \\ &= F(S_b(t); s, t) \left\{ N \left[\frac{\ln \left(\frac{F(S_b(t); s, t)}{K_b} \right) + \frac{\sigma_{bf}^2}{2}}{\sigma_{bf}} \right] \right\} \end{aligned} \quad (7.33)$$

here $N(\cdot)$ represents a cumulative distribution function for the normal distribution. From the second part of Eqn. 7.27 we have

$$\int_{\ln K_b}^{+\infty} \frac{1}{\sigma_{bf}\sqrt{2\pi}} \exp\left\{-\frac{1}{2}\left[\frac{u - \mu_{bs}}{\sigma_{bf}}\right]^2\right\} du \quad (7.34)$$

Now $(\ln K_b - \mu_{bs})/\sigma_{bf}$ can be written as

$$\begin{aligned} & \frac{\ln K_b - \left(\mu_{bs} + \frac{\sigma_{bf}^2}{2}\right) + \frac{\sigma_{bf}^2}{2}}{\sigma_{bf}} \\ &= \frac{\ln K_b - \ln F(S_b(t); s, t) + \frac{\sigma_{bf}^2}{2}}{\sigma_{bf}} \end{aligned} \quad (7.35)$$

Therefore Eqn. 7.34 can be written as follows

$$\begin{aligned}
& 1 - N \left\{ \frac{\ln \left(\frac{K_b}{F(S_b(t);s,t)} \right) + \frac{\sigma_{bf}^2}{2}}{\sigma_{bf}} \right\} \\
&= N \left\{ \frac{\ln \left(\frac{F(S_b(t);s,t)}{K_b} \right) - \frac{\sigma_{bf}^2}{2}}{\sigma_{bf}} \right\} \tag{7.36}
\end{aligned}$$

Inferring from Eqn. 7.27 and combining Eqn. 7.33 and Eqn. 7.36, we have that

$$\begin{aligned}
& E[F(S_b(t); s, t) - K_b, 0]^+ = \\
& F(S_b(t); s, t)N \left\{ \frac{\ln \left(\frac{F(S_b(t);s,t)}{K_b} \right) + \frac{\sigma_{bf}^2}{2}}{\sigma_{bf}} \right\} - K_b N \left\{ \frac{\ln \left(\frac{F(S_b(t);s,t)}{K_b} \right) - \frac{\sigma_{bf}^2}{2}}{\sigma_{bf}} \right\} \tag{7.37}
\end{aligned}$$

Following from Eqn. 6.40, and incorporating the effect of exchange line active, if it is assumed that the risk associated with $\rho_b(t)$ is incorporated in $S_b(t)$, we have

$$\begin{aligned}
& C(F(s, t), K_b, s, t) = \\
& \left\{ F(S_b(t); s, t)N \left\{ \frac{\ln \left(\frac{F(S_b(t);s,t)}{K_b} \right) + \frac{\sigma_{bf}^2}{2}}{\sigma_{bf}} \right\} - K_b N \left\{ \frac{\ln \left(\frac{F(S_b(t);s,t)}{K_b} \right) - \frac{\sigma_{bf}^2}{2}}{\sigma_{bf}} \right\} \right\} * \\
& E[\rho_b(t)] * e^{-r(t-s)} \tag{7.38}
\end{aligned}$$

where

$$\begin{aligned}
& F(S_b(t); s, t) = \\
& \exp \left[S_b(s)e^{-\gamma_{bs}(t-s)} + \alpha_{bs}^*(1 - e^{-\gamma_{bs}(t-s)}) + \frac{\sigma_{bs}^2}{4\gamma_{bs}}(1 - e^{-\gamma_{bs}(t-s)}) \right]
\end{aligned}$$

and where from Eqn. 6.25, the dynamics of $\rho_b(t)$ under objective measures is⁸

$$E[\rho_b(t) | F_s] = \exp \left[\left(\phi_{b\rho} - \frac{1}{2} \sigma_{b\rho}^2 \right) (t - s) \right] \quad (7.39)$$

7.4 Summary

This chapter has developed closed-form analytical solutions to price the value of third-party flexibility to adapt to downstream stochastic processes in the analogue and ADSL capacity markets. These solutions are founded on the properties of the evolution of net average downstream value of an activated exchange line, including its drift and volatility; intensity of line activation, including its drift and volatility; the price of access to the Subscriber Network; the price of market risk; and the price of the risk of default. More generally, these solutions, first, provide a basis for checking the results from the numerical methods in Chapters 5 and 6. Second, these solutions generalize the results and provide an option-theoretic framework for pricing access where third parties have the leverage of adapting to downstream stochastic value. Based on the plausibility of the logic of the analysis, the findings are generalizable as theoretical propositions. Their extrapolation from case to case is based on logical inference.

⁸If it is assumed that the risk associated with $\rho_b(t)$ is not incorporated $S_b(t)$, then $E^Q[\rho_b(t) | F_s]$ applies.

Chapter 8

RESULTS AND DISCUSSION

8.1 Introduction

In Chapters 5 and 6 frameworks were developed for valuing the flexibility of adapting to downstream value in the analogue and ADSL capacity platforms. The subsequent empirical work in the two chapters tested whether FL-LRIC, as a method for pricing access in telecommunications capacity markets is distortionary. The analysis in the two chapters used a numerical method, Monte Carlo Simulation. Chapter 7 developed closed-form analytical solutions to price the value arising from the flexibility of adapting to downstream stochastic processes in the two platforms. These solutions, first, generalize the results and provide an option-theoretic framework for pricing access where third parties have the leverage of adapting to downstream stochastic value. Second, these solutions provide a basis for checking the results produced by the numerical methods. This chapter presents the results from the numerical methods and from the closed-form analytical solutions. We find that the results from the latter method corroborate those from the former method and vice versa.

Based on evidence from the analogue platform covering the period September 1999 to July 2007, and from the standpoint of contingent claim pricing theory, we find that the average distortionary effect of FL-LRIC approximates 8 – 9% of the revenue base of an exchange line and effectively results in a subsidy of 16 – 17% on the regulated price of access, for 1 – 12 month contracts. With respect to the ADSL platform, based on evidence from the period January 2000 to December 2008 from the ADSL capacity access for the 8 mbit/s end-user capacity product, we find that FL-LRIC access prices have a distortionary effect that approximates 7 – 8% of the price of end-to-end connectivity, for 1 – 12 month contracts, for the 8 mbit/s end-user capacity access. Overall

we conclude that: (i) the distortionary effect of FL-LRIC is significant; and (ii) the level of these distortions imply the existence of a strong incentive for inefficient entry.

The findings in this study find empirical support from a number of earlier econometric studies on the effect of policy variables on facilities-based deployment. Relevant examples include those studies by Crandall et al.(2004), Hazlett (2005) and Hausman and Sidak (2005). These studies show that access seekers did not climb the ladder of investment as would be expected under the stepping stone hypothesis. A possible explanation is that the unpriced value arising from cost-based access prices provide disincentives to move up the ladder of investment. Section 8.2 presents the results from the analogue platform and Section 8.3, the results from the ADSL platform.

8.2 Results: Analogue

The parameter estimates of the seasonality function and the corresponding 95% confidence limits are shown in Table 8.1.¹ Figure 8.1 shows the raw data and the fitted curves. The Goodness of fit statistics are shown in Table 8.2.²

¹While this study uses a mean-reverting process of the OU-type to describe $S_a(t)$, and while the explanatory power of this model in explaining the underlying data is fairly persuasive, it is plausible that there are alternative models, including the ARMA model, which can be used to explain the data. The OU-type process however remains a popular model for describing mean-reverting processes in the context of pricing commodity derivatives because of the flexibility it provides to accommodate stochastic volatility, jumps, transformation of the underlying probability space etc. - for relevant literature see, for example, Barlow (2002), Lucia and Schwartz (2002), Burger et al. (2004) and Cartea and Figueroa (2005). The researcher is not aware of studies that have evaluated the relative versatility of OU and ARMA models in the context of modeling the dynamics of downstream value in telecommunication networks. Perhaps the case for doing so will get stronger as longer time series of downstream value become available in the public domain. Intuitively, it is not immediately apparent how the OU-type process cannot cope with the capabilities of ARMA models.

²In both cases, performing the Durbin-Watson Test on the residuals, we observe that the null hypothesis of no correlation between the error terms is rejected at the 5% level of significance. A possible explanation is the use of quarterly data in this study. It may well be that this drawback would be eliminated if monthly data is used. Such data is however not available in the public domain.

Turning to the mean-reversion function with respect to $S_a(t)^*$, the parameter estimates of γ_{as} and σ_{as} and the corresponding 95% confidence limits are 0.1896 (-0.6839, 1.0631) and 0.0063 (0.0053, 0.0072), respectively. The complete set of statistics of the mean-reversion parameters is in Table 8.3. With respect to the ρ -process, the point estimates of the parameters $\phi_{a\rho}$ and $\sigma_{a\rho}$ and the corresponding 95% confidence limits are -0.0023 (-0.0029, -0.0016) and 0.0033 (0.0028, 0.0037), respectively.³

The coefficient correlation of $Y_a(t)$ and $\rho_a(t)$ for the period July 1999 to July 2007 is 0.5056, suggesting a spurious correlation, at least in the short run. Based on this evidence, independence of the two functions is assumed. With respect to the deterministic drivers of value at $t(0)$, $U_a(t) = \pounds 0.02$ based on Eqn. 5.11. At $t(0)$, $K_a(t) = \pounds 8.39$ and remains so for the duration of a regulatory lag.⁴ At $t(0)$, $V_a(t) = \pounds 8.94$ and remains so for the duration of a regulatory lag.⁵ We take risk-free rate, r , to be 3.5% and the risk premium to be 4.0% at $t(0)$ and these values are assumed to remain so for the duration of a regulatory lag.⁶ We consider the valuation of rights in the 12-month period $t(0)$ to $t(12)$. We separately consider 1 to 12-period discrete rights starting at $t(0)$. Here a single period right extends from $t(0)$ to $t(1)$ and a two-period right is the sum of the discrete rights in the 2-month period $t(0)$ to $t(2)$, etc.⁷ For each block of rights, we compare the regulated price of access and the un-priced

³See Section 5.5.2 for the definition of the ρ process.

⁴Ofcom (2005), *Wholesale Line Rental: Reviewing and Setting Charge Ceilings for WLR services*

⁵Ofcom (2005), *Wholesale Line Rental: Reviewing and Setting Charge Ceilings for WLR services*

⁶Arithmetic mean or approximately 3.5% geometric mean. See Wright et. al. (2003). This study uses a CAPM model to estimate the cost of capital and is based on the risk/returns of UK utilities. CAPM has however been subjected to criticism by a number of researchers. Whilst its proponents argue that what is relevant in calculating the cost of capital is systematic risk, its opponents have argued that investors need not necessarily have a diversified portfolio as an investment objective, and therefore in such circumstances what is relevant in determining the cost of capital is both systematic and unique risk. Further, while CAPM assumes that risk-free rates, excess market returns and betas are deterministic, these are in reality stochastic.

⁷Where $t(0)$ is January 2008.

value of flexibility.

In essence for each time interval, there is a downside risk that approximates $-\nu M_a(t) - K_a(t)$, the intensity of which, through time and space is defined by $1 - \rho_a(t)$. Based on the theory of contingent claim valuation, the evidence from the period July 1999 to September 2007 from the UK analogue access market and the assumptions set out in Section 5.3.2, we find that cost-based access prices are distortionary. The overall results are shown in Table 8.4 with respect to the numerical methods. Table 8.5 shows the results from analytical methods. The results from the numerical methods corroborate those from analytical methods and vice versa. In both cases Scenario I assumes that the risk associated with $\rho_a(t)$ is incorporated in $S_a(t)$ and in Scenario II it is assumed otherwise. The alternative assumptions underlying Scenarios I and II are deemed to be the two most plausible ways of investigating the questions that are the subject of this thesis. A third contender is not obvious. Ultimately, however the difference in the results produced by the two approaches is small, in the case here, because of the low volatility of activation. The sensitivity analysis, shown in Table 8.6, based on Scenario II, indicates that the value of the option is most sensitive to the level of line activation, traffic levels and the price of access to the Subscriber Network. In effect a 5% change in the level of $\rho_a(0)$ results in about the same change in the value of the option; a 5% change in the level of β_s results in a 6% change in the value of the option; and a 5% change in the level of $K_a(t)$ results in a -22% of the same value.

Further, the analysis in this chapter is based on quarterly data. The volatilities exhibited by such data will be conservative estimates actual volatilities. This drawback results in conservative estimates of market risk, and therefore the value of the underlying optionality. In order to address this drawback, supplementary scenarios are developed where the respective volatilities are multiples of those in the base case - see results in Table 8.7. In doing this it is recognized that such variation has two opposing effects - on one hand a more pronounced reduction of the underlying risk premium and on the other an increase in the

value of optionality.

Considered in isolation, the observed low volatilities associated with market risk and the observed level of $K_a(t)$ suggest optionality deep in the money. However, it is recognized that the overall value of optionality will be depend on the composite effect market risk and default risk - see Eqn. 5.1. It is appreciated that different service lines will exhibit varying degrees of market risk and indeed some lines will have volatilities, associated with market risk, that are more pronounced than those observed in this study. Overall, however the model developed for the analogue platform is versatile enough to cater for all levels of volatility of market risk and default risk, and therefore provides a basis for analytical generalisations.

Based on evidence from the analogue platform covering the period September 1999 to July 2007, and from the standpoint of contingent claim pricing theory, we find that the average distortionary effect of FL-LRIC approximates 8 – 9% of the revenue base of an exchange line and effectively results in an subsidy of 16 – 17% on the regulated price of access, for 1 – 12 month contracts. Overall we conclude that: (i) the distortionary effect of FL-LRIC is significant; and (ii) the level of these distortions imply the existence of a strong incentive for inefficient entry.

8.3 Results: ADSL

The parameters of $S_b(t)^*$, i.e. γ_{bs} , σ_{bs} and α_{bs} , and the corresponding 95% confidence limits are estimated to be 0.9401 (–0.4941, 2.3744), 0.0948 (0.0754, 0.1142) and 2.2728 (2.1752, 2.3703), respectively. With respect to the deterministic drivers of value at $t = 0$, $U_b(t) = \text{£}13.34$, based on Eqn. 6.32, comprising $\text{£}9.73$ and $\text{£}3.61$ in respect of conveyance in the core network and backhaul, respectively (see relevant raw data in Tables E.7 to E.11 in Appendix E). Now at $t = 0$, $M_b(t)$ is $\text{£}3.94$, of which $\text{£}1.44$ accounts for IP Transit⁸ and $K_b = \text{£}7.05$

⁸Cost $\text{£}9/\text{month}/\text{Mbit}/\text{s}$ - See <http://www.datahop.it/DatahopTransit.php>

- see Table E.10 in Appendix E. The deterministic drivers of value remain constant during the regulatory lag. We take risk-free rate, r , to be 3.5% and the risk premium to be 4.0% at $t = 0$. These remain constant for the duration of the regulatory lag. We consider the valuation of rights in the period $t = 0$ to $t = 12$. We separately consider 1 to 12-period rights starting at $t = 0$. As with analogue access, a single period right extends from $t(0)$ to $t(1)$ and a two-period right is the sum of the discrete rights in the two-month period $t(0)$ to $t(2)$, etc.⁹ For each block of rights, we compare the option value relative to the price of end-to-end connectivity. As with the analysis of the analogue platform, the analysis in this section assumes two scenarios. Scenario I assumes the case where the risk associated with $\rho_b(t)$ is incorporated in $S_b(t)$, and Scenario II assumes that the risk associated with $\rho_b(t)$ is not incorporated in $S_b(t)$. The alternative assumptions underlying Scenarios I and II are deemed to be the two most plausible ways of investigating the questions that are the subject of this thesis. A third contender is not obvious. As with the analysis in Section 8.2, ultimately, the difference in the results produced by the two approaches is small, in the case here, because of the low volatility of activation. Tables 8.8 and 8.11 show the results under the two scenarios.

The estimates of the volatility of downstream value in the base case is based on parameters discerned from data in the public domain including the simple average of headline tariffs (see raw data in Tables E.4 and E.5 in Annex E), average churn¹⁰ and promotional discounts availed to new subscribers (see raw data in Table E.6 in Annex E). While these provide a basis for first order approximations, it is recognized that the actual volatility of downstream value will be more pronounced because of, for example, the combined effect of shifting market shares and the differentials in tariffs between different service providers, changes in the levels of promotional discounts offered to new subscribers and changes in churn rates between different service providers. Such conservative

⁹Where $t(0)$ is January 2009.

¹⁰See Telebusillis' estimate at <http://telebusillis.blogspot.com/>

estimates of volatility will suggest low values of optionality if one considers market risk in isolation. The value of optionality will however be more pronounced if one considers the simultaneous effect of market risk and default risk - see Eqn 6.1. It is appreciated that different service lines will exhibit varying degrees of market risk and indeed some lines will have volatilities that are more pronounced than those observed in this study. Overall, however, the model developed for the ADSL platform is versatile enough to cater for all levels of volatility of market risk and default risk.

In order to accommodate a conceivable more elevated level of volatility, further scenarios are developed where the respective volatilities are multiples of those in the base case - see Table 8.12. Table 8.10 shows a sensitivity analysis based on the base case. This indicates that the value of the option is most sensitive to the level of line activation, tariff levels and the price of access to the Subscriber Network. In effect a 5% change in the level of $\rho_b(0)$ results in about the same change in the value of the option. The same perturbation in α_{bs} results in a 16% change in the option value, and 5% change in $K_b(t)$ results in a -14% change.

The results from the closed-form analytical methods are shown in Table 8.9. These results corroborate those from numerical methods and vice versa. Based on contingent claim pricing theory, the assumptions set out in Section 6.3.1 and the evidence from the period January 2000 to December 2008 from the ADSL capacity access for the 8 mbit/s end-user capacity product, we find that that FL-LRIC access prices are distortionary. In essence for each unit of time, for 8 mbit/s end-user capacity access, there is a downside risk that approximates $-\nu M_b(t) - \nu N_b(t) - K_b(t)$, the intensity of which is defined by $1 - \rho_b(t)$. The results show that FL-LRIC access prices have a distortionary effect that approximates 7–8% of the price of end-to-end connectivity, for 1–12 month contracts, for 8 mbit/s end-user capacity access. Overall we conclude that: (i) the distortionary effect of FL-LRIC is significant; and (ii) the level of these distortions imply the existence of a strong incentive for inefficient entry.

8.4 Discussion

The asymmetry that arises from having the right without the corresponding obligation to invest, and the resultant exposure to the upside without a corresponding exposure to the downside renders mandatory unbundling in telecommunication capacity networks amenable to scrutiny using the framework of financial options valuation. The quantitative approaches to pricing financial options find their origin in the seminal work by Black and Scholes (1973) and Merton (1973). The Black-Scholes model finds application in circumstances where the value of the underlying asset is defined by a continuous-time stochastic process. The subsequent work by Cox, Ross and Rubinstein (1979) provide a framework for valuing options where the value of the underlying asset is defined by a discrete-time stochastic process. The premise underpinning the valuation of an option on the spot is that a portfolio consisting of n shares in the underlying asset and risk-free borrowing can be constructed to replicate the value of an option on the underlying asset. Since the option and the replicating portfolio would have the same returns, these two assets must sell for the same price to avoid arbitrage opportunities. Black (1976) showed how arbitrage arguments can be used to price options on futures contracts. The pricing of options on futures contracts is based on the tenet that a riskless portfolio can be constructed by creating a portfolio consisting of a short position in one option contract and a long position in n futures contracts. In the discrete time set-up the value of the option is given by

$$C(F(t, T)) = [qF_u + (1 - q)F_d] * e^{-(T-t)} \quad (8.1)$$

where F_u is the pay-off on the forward in favourable circumstances and F_d is the pay-off in unfavourable circumstances. Here q represents risk-neutral probabilities. In continuous time, Black derives a closed-form analytical solution to price an option on a futures contract, where futures prices have a lognormal

distribution, as follows

$$C(F(t) : t, T) = e^{-r(T-t)}[F(t, T)N(d_1) - KN(d_2)] \quad (8.2)$$

here

$$d_1 = \frac{\ln\left(\frac{F(t, T)}{K}\right) + \frac{1}{2}\sigma^2(T-t)}{\sigma\sqrt{T-t}}$$

and

$$d_2 = d_1 - \sigma\sqrt{T-t}$$

for $T > t$. Now $F(t, T)$ is the price of a futures contract written at time t for delivery at time T . We know that $F(t, T) = E^Q[S(t, T)]$.

This study is built on the debate in the literature by Hausman (1999), Economides (1999), Hausman and Myers (2002), Alleman (2002), Alleman and Rappoport (2002, 2005, 2006), Vogelsang (2003), Pindyck (2005a, 2005b, 2007) and Cave (2006) and makes four contributions to the debate. First, it provides a rigorous analytical framework, founded on the stochastic dynamics of downstream value, for valuing the flexibility of adapting to downstream value. Second, it provides empirical evidence on the symmetry or otherwise of FL-LRIC access prices based on evidence from the analogue platform. Third, it provides similar evidence from the ADSL platform. These contributions set this study apart from previous studies and take the debate in the literature beyond the current qualitative conjectures. Fourth, based on the aforesaid evidence, this study provides closed-form analytical solutions to price the value of third-party flexibility to adapt to downstream stochastic processes in the two platforms. These solutions generalize the results and provide an option-theoretic approach for pricing capacity access where third parties have the leverage of adapting

to downstream stochastic value. In this regard too, this study ‘is significantly different from previous research in the field.

With respect to the first three contributions, this study repudiates earlier ideas. The hypothesized neutrality of FL-LRIC has been tested to see if can stand up to the evidence, within the framework of the hypothetico-deductive method. From this epistemological standpoint, theories can only be held as tentative conjectures until falsified through empirical investigation. At any time therefore, a theory only reflects the distance travelled in a particular field. Weak theories are driven out by new evidence and new theories emerge. Only those theories which have not been refuted and which best correspond to empirical evidence persist - but only until superior theories are developed. Through this sequence more versatile theories emerge. Popper (1963) argued that deduction and falsification - the hypothetico deductive method – is central to constructing knowledge.

This thesis finds that FL-LRIC is distortionary as an approach for pricing capacity access. These findings are corroborated by the findings from a number of earlier econometric studies on the effect of policy variables on facilities-based deployment. Relevant examples include those studies by Crandall et al. (2004), Hazlett (2005) and Hausman and Sidak (2005). These studies show that access seekers did not climb the ladder of investment as would be expected under the stepping stone hypothesis. A possible explanation is that the unpriced value arising from cost-based access prices provide disincentives to move up the ladder of investment. Crandall et al.(2004) find that UNE lines in access seekers’ portfolios increased from 24% in 1999 to 55% in 2002. This evidence suggests that access seekers did not migrate to facilities-based competition as would be expected under the ladder of investment hypothesis. Hazlett (2005) finds that during period 1999 to 2004, UNE-P lines emerged to dominate the portfolios of access seekers. During this period UNE-P lines grew by over 300% and facilities-based lines grew by just 20%. Hazlett finds that the correlation between the growth of UNE-P lines and non-cable facilities-based competition is -0.99 and

concludes that UNE-P lines crowd out facilities-based competition. Of interest too is the fact that during the period 1999 to 2004, while the lines operated by access seekers reflected a continuous period-to-period increase, the level of their non-cable facilities-based lines showed a decline bringing to doubt the "stepping stone" hypothesis. Hazlett also finds that investments by incumbents and access seekers are negatively correlated to the growth of shared lines (coefficient of correlation for 2000 to 2003: -0.94). Hazlett further finds that the rate of deployment of DSL increased after the repeal of the mandatory line sharing requirements in the US. Hausman and Sidak (2005) follow the evolution of lines operated by 17 access seekers in 2000 and find that 25% of these operators increased the proportion of facility-based lines in their portfolio - 50% of the firms maintained about the same proportion of facilities-based lines. Some firms went bankrupt and others decreased their share of facilities-based competition.

It has been suggested in some literature that a possible way to deal with the asymmetries resulting from the option-like characteristics of third-party capacity access in telecommunication networks is to top-up the wholesale access price by a marginal amount say 5-10% (see Waverman, 2006). This remedy however falls short of addressing the fundamental character of the asymmetrical distribution of risk in the access infrastructure. Increasing the wholesale price of access is equivalent to increasing the strike price. While this reduces the value of flexibility, it does not eliminate such value. What is required, given a portfolio of exchange lines where a third party has the leverage to migrate from node to node, is a two-part access charge. Here the first part would be chargeable on account of the flexibility to migrate from node to node within a network and would take effect, for each exchange line within a portfolio, whether or not access is sought. Eqn. 7.1 and Eqn. 7.23 provide expressions representing the value of this charge for the analogue and ADSL platforms, respectively. The second part would be chargeable per exchange line if and when access is sought, and is equal to $K_a(t)$. Turning to directions for regulatory policy, the results point to three possible remedies. First, binding the access

seekers, through space and time to an extent necessary to eliminate one-sided advantages through some form of take-or-pay arrangements, or some variation of this type of contract. Second, migrating to a pricing mechanism that is sensitive to the value of the flexibility to adapt to downstream stochastic processes, through space and time. In this regard the option-theoretic approach to pricing access that is furthered in Chapter 7 contributes to a possible policy direction. A third possible policy remedy is co-investment where the incumbent and the access seekers jointly own access infrastructure and jointly share the upside and downside potential. It is however recognized that the legal basis for effecting such an arrangement may be problematic unless such an arrangement is willingly accepted by the parties to the contract. In the absence of such consent, the basis in law to impose a shareholding structure on an incumbent may be lacking.

While this thesis contributes to the debate, it is however constrained by the limitations of data in the public domain. The study could be improved in number of ways if the availability of data was not a limitation. First, this study assumes that the intensity of exchange line activation is uniform throughout the market studied. However relevant evidence shows that the extent of competition varies from exchange to exchange. More specifically, as discussed more fully in Chapter 7, cable had 95%+ presence in service areas covered by 48 local exchange. Overall subscribers have a choice of more than one access platform in about one half of the downstream market and the magnitude of the risk of stranded assets varies from exchange to exchange - see Figures F.1 and F.2 in Appendix F. This suggests that the stochastic state of exchange lines and therefore the value of flexibility will vary also from exchange to exchange. Given this, a more appropriate way to structure the study is to stratify the various exchanges areas based the stochastic dynamics of the exchange lines. This has not been done because of the lack of data.

Second, while this study assumes a representative portfolio of exchange lines through space and estimates option values from this standpoint, in practice

however access seekers have the leverage to work their way through space and cherry pick high-end subscribers with high and stable demand. Clearly the distortionary effect of FL-LRIC increases, taking the analogue network as an example, if $S_{ai}(t)$ is consistently greater than $\alpha_{as}(t)$. The results from the study should therefore be seen as a conservative estimate of the distortionary effect of FL-LRIC. Third, with respect to the ADSL platform, this research is confined to wholesale access for the 8 mbit/s end-user capacity because of lack of data on other capacities. While this capacity accounts for 43% of the UK market (see Ofcom, 2008), this study could be extended to other capacities if data was not a constraint. Fourth, we use quarterly data where monthly data is not available and interpolate to estimate monthly data points. While this approach has been used by researchers in the face of data constraints, for example, Henisz and Zelner (2001), it nevertheless adds noise to the data set.

Further, this study is based on the case where a third-party purchases end-to-end connectivity. It is however recognized that an access seeker may opt to purchase only subset of the network elements required to provide end-to-end connectivity, and supplement these with their own elements. Such an alternative results in a risk profile that differs from that studied here and presents an area for further research. The broad principles established in this study can be extended to cover such a scenario. Lastly, this study is based on data covering a period of 8 years with respect to the analogue platform and 9 years with respect to the ADSL platform. While one could argue that a longer time series should have been obtained to provide a firmer basis to model the evolution of the drivers of value, it should however be noted that the length of the historical data points used in the study was limited by what is available in the public domain. In mitigation, one could argue that a regulatory lag is of a short-run duration and therefore what is required is reasonable evidence of short-run dynamics.

8.5 Summary

From the evidence from the analogue platform covering the period January 2000 to July 2007, the assumptions set out in Section 5.3.2 and from the standpoint of contingent claim pricing theory, we find that the average distortionary effect of FL-LRIC approximates 8 – 9% of the revenue base of an exchange line and effectively results in an subsidy of 16 – 17% on the regulated price of access, for 1 – 12 month contracts. With respect to the ADSL platform, based on option pricing theory, the evidence from the period January 2000 to December 2008 from the ADSL capacity access for the 8 mbit/s end-user capacity product and the assumptions set out in Section 6.3.1, we find that that FL-LRIC access prices have a distortionary effect that approximates 7 – 8% of the price of end-to-end connectivity, for 1 – 12 month contracts. Overall we conclude that: (i) the distortionary effect of FL-LRIC is significant; and (ii) the level of these distortions implies the existence of a strong incentive for inefficient entry.

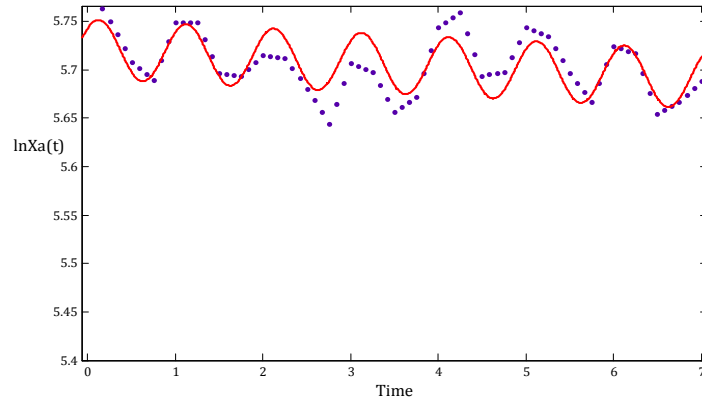

Figure 8.1: Analogue - Traffic (Raw Data and Fitted Curves)

		Point	95% Confidence
		Estimate	Limits
Traffic	β_x	5.73	(5.719, 5.740)
	ξ_x	-0.0078	(-0.0101, -0.0055)
	η_x	0.02925	(0.0221, 0.0364)
	ω_x	2π	-
	ν_x	$\pi/4$	-
D/S Value	β_s	2.3420	(2.340, 2.344)
	ξ_s	-0.0018	(-0.023, -0.0013)
	η_s	0.0068	(0.0052, 0.0084)
	ω_s	2π	-
	ν_s	$\pi/4$	-

Table 8.1: Analogue - Seasonality (Parameter Estimates)

	Traffic	D/Stream
	Value	
SSE	0.0522	0.0028
R-Square	0.5610	0.5665
Adjusted R-Square	0.5510	0.5566
RMSE	0.0244	0.0056

Table 8.2: Analogue - Seasonality (Goodness of Fit)

	Parameter	95% Confidence
	Estimate	Limits
γ_{as}	0.1896	(-0.6839, 1.0631)
σ_{as}	0.0063	(0.0053, 0.0072)

Table 8.3: Analogue - Downstream Value (Mean-reversion Parameters)

Dur.	Scenario I			Scenario II		
	Option Value - £	Std.		Option Value - £	Std.	
		Error x10 ⁻⁴	Cum. Value - £		Error x10 ⁻⁴	Cum. Value- £
1	1.4334	0.1322	1.4334	1.4333	0.1322	1.4333
2	1.4317	0.1859	2.8651	1.4314	0.1858	2.8647
3	1.4166	0.2256	4.2817	1.4162	0.2256	4.2809
4	1.3921	0.2554	5.6738	1.3916	0.2553	5.6725
5	1.3640	0.2832	7.0378	1.3634	0.2831	7.0359
6	1.3396	0.3077	8.3773	1.3388	0.3076	8.3747
7	1.3249	0.3326	9.7022	1.3240	0.3324	9.6987
8	1.3232	0.3495	11.0254	1.3222	0.3492	11.0210
9	1.3346	0.3688	12.3600	1.3335	0.3685	12.3544
10	1.3556	0.3888	13.7156	1.3544	0.3885	13.7088
11	1.3801	0.4037	15.0957	1.3788	0.4033	15.0876
12	1.4012	0.4176	16.4969	1.3997	0.4171	16.4873

Table 8.4: Analogue - Summary of Results (Numerical Methods)

Dur.	Scenario I	Scenario II
	Option	Option
	Cum.	Cum.
	Value - £	Value - £
1	1.430	1.430
2	2.854	2.854
3	4.260	4.259
4	5.637	5.637
5	6.983	6.982
6	8.302	8.300
7	9.603	9.600
8	10.898	10.895
9	12.201	12.197
10	13.521	13.516
11	14.861	14.855
12	16.219	16.211

Table 8.5: Analogue - Summary of Results (Analytical Methods)

Parameter	Effect	Parameter	Effect
	of 5% Perbutation		of 5% Perbutation
λ_1	-0.03%	σ_{as}	-0.03%
ϕ_{ap}	0.01%	β_s	6.17%
σ_{ap}	0.01%	ξ_s	-0.03%
Rf Rate	-0.01%	η_s	-0.19%
γ	0.03%	$K_a(t)$	-22.21%
$\rho_a(t)$	5.00%		

Table 8.6: Analogue - Sensitivity Analysis (Scenario II)

Dur.	Perturbation (x2)			Perturbation (x5)			Perturbation (x10)		
	Option	Std.		Option	Std.		Option	Std.	
		Error	Cum.		Error	Cum.		Error	Cum.
Value - £	x10 ⁻⁴	Val. - £	Value - £	x10 ⁻³	Val. - £	Value - £	x10 ⁻⁴	Val. - £	
1	1.4319	0.2672	1.4319	1.4279	0.0690	1.4279	1.4217	0.1457	1.4217
2	1.4286	0.3756	2.8605	1.4207	0.0960	2.8485	1.4083	0.2043	2.8300
3	1.4121	0.4558	4.2726	1.001	0.1175	4.2487	1.3815	0.2476	4.2115
4	1.3862	0.5157	5.6588	1.3706	0.1329	5.6193	1.3465	0.2795	5.5581
5	1.3567	0.5717	7.0155	1.3374	0.1472	6.9567	1.3076	0.3094	6.8657
6	1.3309	0.6210	8.3464	1.3079	0.1597	8.2646	1.2725	0.3352	8.1381
7	1.3149	0.6710	9.6614	1.2885	0.1725	9.5532	1.2479	0.3616	9.3860
8	1.3118	0.7048	10.9732	1.2819	0.1810	10.8351	1.2357	0.3791	10.6217
9	1.3219	0.7435	12.2951	1.2885	0.1909	12.1235	1.2369	0.3993	11.8586
10	1.3416	0.7835	13.6367	1.3046	0.2010	13.4281	1.2477	0.4199	13.1064
11	1.3647	0.8133	15.0014	1.3241	0.2085	14.7523	1.2617	0.4353	14.3680
12	1.3844	0.8411	16.3858	1.3402	0.2155	16.0925	1.2722	0.4495	15.6402

Table 8.7: Analogue - Summary of Results, Numerical Methods (With Perturbation)

Dur.	p b (0)=0.70			p b (0)=0.75			p b (0)=0.80		
	Option	Std.		Option	Std.		Option	Std.	
		Error	Cum.		Error	Cum.		Error	Cum.
Value - £	Error	Value - £	Value - £	Error	Value - £	Value - £	Error	Value - £	
1	1.8440	0.0016	1.8440	1.9758	0.0018	1.9758	2.1075	0.0019	2.1075
2	1.8280	0.0021	3.6721	1.9586	0.0022	3.9344	2.0892	0.0024	4.1967
3	1.8094	0.0023	5.4815	1.9386	0.0024	5.8730	2.0679	0.0026	6.2645
4	1.8011	0.0023	7.2825	1.9297	0.0025	7.8027	2.0584	0.0027	8.3229
5	1.7872	0.0024	9.0697	1.9148	0.0025	9.7175	2.0425	0.0027	10.3654
6	1.7733	0.0024	10.8430	1.8999	0.0025	11.6175	2.0266	0.0027	12.3920
7	1.7659	0.0024	12.6089	1.8921	0.0025	13.5096	2.0182	0.0027	14.4102
8	1.7544	0.0023	14.3633	1.8797	0.0025	15.3893	2.0050	0.0026	16.4152
9	1.7464	0.0023	16.1097	1.8712	0.0024	17.2604	1.9959	0.0026	18.4111
10	1.7397	0.0022	17.8494	1.8639	0.0024	19.1244	1.9882	0.0026	20.3993
11	1.7309	0.0022	19.5804	1.8546	0.0023	20.9790	1.9782	0.0025	22.3775
12	1.7225	0.0021	21.3029	1.8456	0.0023	22.8245	1.9686	0.0024	24.3462

Table 8.8: ADSL - Summary of Results, Numerical Methods (Scenario I)

Dur.	Option Value - £		
	$p_b(0)=0.70$	$p_b(0)=0.75$	$p_b(0)=0.80$
1	1.838	1.969	2.100
2	3.655	3.916	4.177
3	5.453	5.843	6.232
4	7.233	7.750	8.267
5	8.996	9.639	10.281
6	10.743	11.510	12.278
7	12.475	13.366	14.257
8	14.192	15.206	16.220
9	15.896	17.032	18.167
10	17.587	18.843	20.100
11	19.266	20.642	22.018
12	20.933	22.428	23.923

Table 8.9: ADSL - Summary of Results, Scenario I (Analytical Methods)

Parameter	Effect	Parameter	Effect
	of 10% Perbutation		of 10% Perbutation
λ_1	-0.24%	γ_{bs}	0.01%
$\rho_b(t)$	5.00%	σ_{bs}	-0.22%
Rf Rate	-0.01%	$K_a(t)$	-13.88%
α_{bs}	16.54%		

Table 8.10: ADSL - Sensitivity Analysis (Scenario II)

Dur.	$pb(0)=0.70$			$pb(0)=0.75$			$pb(0)=0.80$		
	Option	Std.	Cum.	Option	Std.	Cum.	Option	Std.	Cum.
	Value - £	Error	Value - £	Value - £	Error	Value - £	Value - £	Error	Value - £
1	1.8439	0.0016	1.8439	1.9756	0.0018	1.9756	2.1073	0.0019	2.1073
2	1.8277	0.0021	3.6716	1.9583	0.0022	3.9338	2.0888	0.0024	4.1961
3	1.8089	0.0023	5.4805	1.9381	0.0024	5.8719	2.0673	0.0026	6.2634
4	1.8004	0.0023	7.2809	1.9290	0.0025	7.8010	2.0576	0.0027	8.3210
5	1.7864	0.0024	9.0672	1.9140	0.0025	9.7149	2.0415	0.0027	10.3626
6	1.7723	0.0024	10.8396	1.8989	0.0025	11.6138	2.0255	0.0027	12.3881
7	1.7648	0.0024	12.6044	1.8909	0.0025	13.5047	2.0169	0.0027	14.4050
8	1.7531	0.0023	14.3575	1.8783	0.0015	15.3830	2.0036	0.0026	16.4086
9	1.7450	0.0023	16.1025	1.8696	0.0024	17.2527	1.9943	0.0026	18.4028
10	1.7381	0.0022	17.8406	1.8623	0.0024	19.1149	1.9864	0.0026	20.3892
11	1.7292	0.0022	19.5698	1.8527	0.0023	20.9677	1.9763	0.0025	22.3655
12	1.7207	0.0021	21.2905	1.8436	0.0023	22.8112	1.9665	0.0024	24.3320

Table 8.11: ADSL - Summary of Results, Numerical Methods (Scenario II)

Dur.	$pb(0)=0.75$ - With Perturbation								
	Perbutation (x2)			Perbutation (x5)			Perbutation (x10)		
	Option	Std.	Cum.	Option	Std.	Cum.	Option	Std.	Cum.
	Value - £	Error	Value - £	Value - £	Error	Value - £	Value - £	Error	Value - £
1	1.9605	0.0035	1.9605	1.9281	0.0088	1.9281	2.0300	0.0160	2.0300
2	1.9276	0.0044	3.8881	1.8732	0.0108	3.8013	2.0844	0.0194	4.1144
3	1.8888	0.0049	5.7769	1.8021	0.0116	5.6033	2.0665	0.0209	6.1809
4	1.8722	0.0050	7.6491	1.7794	0.0118	7.3827	2.0855	0.0215	8.2664
5	1.8434	0.0051	9.4925	1.7258	0.0119	9.1085	2.0371	0.0218	10.3035
6	1.8147	0.0051	11.3072	1.6688	0.0117	10.7773	1.9722	0.0216	12.2757
7	1.7998	0.0051	13.1071	1.6385	0.0118	12.4158	1.9622	0.0217	14.2379
8	1.7759	0.0049	14.8830	1.5874	0.0114	14.0032	1.8826	0.0211	16.1205
9	1.7597	0.0049	16.6427	1.5521	0.0112	15.5553	1.8357	0.0208	17.9561
10	1.7460	0.0048	18.3887	1.5203	0.0111	17.0756	1.8064	0.0206	19.7626
11	1.7280	0.0047	20.1167	1.4812	0.0108	18.5568	1.7366	0.0201	21.4992
12	1.7106	0.0046	21.8273	1.4402	0.0106	19.9971	1.6657	0.0196	23.1649

Table 8.12: ADSL - Summary of Results, Numerical Methods (Scenario II - Perturbed)

Chapter 9

CONCLUSION

Mandatory third-party wholesale access to an incumbent's infrastructure is discussed in the literature as a means for introducing facilities-based competition in the fixed-wire network. The rationale for this argument is that third parties are provided with an impetus for investment in their own networks, if they are allowed to rent bottleneck facilities at an initial stage of competition, creating in the process rival networks, hence facilities-based competition. It has further been argued that mere re-packaging and resale of an incumbent's downstream services, by itself, does not create value.

The search for an appropriate approach to pricing has evolved variously in the literature through rate of return regulation, the Efficient Component Pricing Rule, price-cap regulation (RPI-X) and cost-based regulation, based on efficient forward-looking costs (FL-LRIC) – all in search for an approach that would send signals for efficiency to the users of the access infrastructure and thereby facilitate the longer-term efficient development of access networks. In some literature and indeed in practice the search for an approach to pricing access has for the time being settled on cost-based access prices based on long-run incremental costs. This approach to access pricing has been advanced in a considerable body of literature as an effective instrument for incentive regulation in telecommunication access networks. Its proponents have argued that access seekers pay a price, and access providers receive a price that corresponds to the costs that the latter imposes on access infrastructure. Consequently, access seekers bear a cost that is equivalent to the cost of supply. In this respect, it is argued that FL-LRIC, is not only equitable to the access provider but induces entry from access seekers who are as efficient or more so than the access provider in the intermediate services market.

In the EU, for example, the European Commission in its Recommendation 98/195/EC of 8th January 1998, on the subject of interconnection in a liberalised telecommunications market, recommended the use of long-run average incremental costs as a basis for setting access charges. The European Parliament and Council subsequently in Directive (2000) 384 on access to, and interconnection of, electronic communication networks and associated facilities, also adopted FL-LRIC as basis for setting interconnection prices. In November 2000 the Independent Regulators Group (IRG) endorsed FL-LRIC as basis for setting interconnection prices. According to the IRG most of its members have introduced FL-LRIC. Further, the European Parliament and Council, in Directive 2002/19/EC on access to, and interconnection of electronic networks and associated facilities, stipulated cost-based access prices as a means of regulating capacity access.

Some emerging literature questions the versatility of FL-LRIC. At the centre of the debate is the issue about the versatility of this approach to pricing access in responding to the distribution of downstream risk. Of particular importance is the question about whether the relative value of the flexibility to respond to downstream stochastic processes is significant relative to the financial equilibrium of access seekers, and whether therefore any such value if unpriced adversely influences market outcomes. These questions are central to the regulation of capacity access in telecommunications for a number reasons. First, from a theoretical standpoint, a material overstatement of access prices reinforces the dominant position of the incumbent, puts upward pressure on the price of downstream products and distorts the competitive neutrality between alternative technology platforms - a material understatement of access prices encourages inefficient entry, stifles the ability of an incumbent to sustain and improve its infrastructure and distorts the competitive neutrality between competing technology platforms. Second, even if subsidized entry is suggested on grounds that it stimulates competition, it has been argued that the terms of access should mirror a voluntary exchange and reflect the full economic cost

of the underlying service.

This study has built on the debate in the literature by Hausman (1999), Economides (1999), Hausman and Myers (2002), Alleman (2002), Alleman and Rappoport (2002, 2005, 2006), Vogelsang (2003), Pindyck (2005a, 2005b, 2007) and Cave (2006) and makes four contributions to the debate. First, it provides a rigorous analytical framework, founded on the stochastic dynamics of downstream value, for valuing the flexibility of adapting to downstream value. Second, it provides empirical evidence on the symmetry or otherwise of FL-LRIC access prices based on evidence from the analogue platform in the UK. Third, it provides similar evidence from the ADSL platform. These contributions set this study apart from previous studies and take the debate in the literature beyond the current qualitative conjectures. Fourth, based on the aforesaid evidence, this study provides closed-form analytical solutions to price the value of third-party flexibility to adapt to downstream stochastic processes in the two platforms. These solutions generalize the results and provide an option-theoretic approach for pricing capacity access where third parties have the leverage of adapting to downstream stochastic value. In this regard too, this study is significantly different from previous research in the field.

With respect to the first three contributions, this study questions earlier ideas on the symmetry of FL-RIC. The hypothesized neutrality of FL-LRIC has been tested to see if can stand up to the evidence. Theories can only be held as tentative conjectures until falsified through empirical investigation. At any time therefore, a theory only reflects the distance travelled in a particular field. Weak theories are driven out by new evidence and new theories emerge. Only those theories which have not been refuted and which best correspond to empirical evidence persist - but only until superior theories are developed. Through this sequence more versatile theories emerge.

The theoretical framework in this thesis is option pricing theory. This theory is used because of its capacity to conceptualize and quantify the value of flexibility. This theory finds its origins in Black and Scholes (1973) and the

subsequent enhancements in Merton (1973). This thesis draws on Black (1976) who showed how futures prices can be used to price contingent claims, based on arbitrage arguments. The contribution by Black is particularly important in commodity markets where futures and forward prices are either observable or can be reasonably inferred. We have applied the theory using risk-neutral pricing principles developed by Harrison and Kreps (1979), and Harrison and Pliska (1981, 1983). In applying risk-neutral pricing, the price of market risk and the price of the risk of default are taken as handles which link P -dynamics to Q -dynamics.

The analysis in this study draws on an intensity-based approach to contingent claim valuation. This approach finds application in circumstances where there exists a risk of default which is either totally or partially independent of the value of the underlying assets. This approach therefore recognizes two main sources of risk i.e. market risk and asset-specific default risk. The intensity-based approach recognizes that at each instant, there is a possibility of default arising from reasons other than the value of the underlying asset. Default is allowed to occur before the maturity of the underlying asset and is triggered by an exogenous process which is either fully or partially independent of the value of the underlying asset.

This study finds that FL-LRIC is distortionary as an approach for pricing capacity access. Based on evidence from the analogue platform covering the period September 1999 to July 2007, and from the standpoint of contingent claim pricing theory, we find that the average distortionary effect of FL-LRIC approximates 8 – 9% of the revenue base of an exchange line and effectively results in a subsidy of 16–17% on the regulated price of access, for 1–12 month contracts. With respect to the ADSL platform, based on contingent claim pricing theory and the evidence from the period January 2000 to December 2008 from the ADSL capacity access for the 8 mbit/s end-user capacity product, we find that that FL-LRIC access prices are distortionary. The results show that FL-LRIC access prices have a distortionary effect that approximates 7 – 8% of

the price of end-to-end connectivity, for 1–12 month contracts, for 8 mbit/s end-user capacity access. Overall we conclude that: (i) the distortionary effect of FL-LRIC is significant; and (ii) the level of these distortions imply the existence of a strong incentive for inefficient entry.

These findings are corroborated by the findings in a number of earlier econometric studies on the effect of policy variables on facilities-based deployment. These studies point to the following conclusions - first, that the price of access to the local loop is positively correlated to inter-platform competition (see Crandal et al., 2004 and Waverman et al., 2007). Second, that intra-platform competition is negatively correlated to facilities-based deployment (see Hazlett, 2005). Third, that access seekers did not climb the ladder of investment, as envisaged under the stepping stone hypothesis, based on US experience (see Crandall et al. 2004, Hazlett, 2005 and Hausman and Sidak, 2005).

It has been suggested in some literature that a possible way to deal with the asymmetries resulting from the option-like characteristics of third-party capacity access in telecommunication networks is to top-up the wholesale access price by a marginal amount say 5-10% (see Waverman, 2006). This remedy however falls short of addressing the fundamental character of the asymmetrical distribution of risk in the access infrastructure. Increasing the wholesale price of access is equivalent to increasing the strike price. While this reduces the value of flexibility, it does not eliminate such value.

Turning to directions for regulatory policy, the results point to three possible remedies. First, binding the access seekers, through space and time to an extent necessary to eliminate one-sided advantages through some form of take-or-pay arrangements, or some variation of this type of contract. Second, migrating to a pricing mechanism that is sensitive to the value of the flexibility to adapt to downstream stochastic processes, through space and time. In this regard the option-theoretic approach to pricing access that is furthered in Chapter 7 contributes to a possible policy direction. A third possible policy remedy is co-investment where the incumbent and the access seekers would jointly own

access infrastructure and jointly share the upside and downside potential. It is however recognized that the legal basis for effecting such an arrangement may be problematic unless the arrangement is willingly accepted by the parties to the contract. In the absence of such consent, the basis in law to impose a shareholding structure on an incumbent may be lacking.

While this study contributes to the debate, it is however constrained by the limitations of data in the public domain. The study could be improved in number of ways if the availability of data was not a limitation. First, this study assumes that the intensity of exchange line activation is uniform throughout the market studied. However relevant evidence shows that the extent of competition varies from exchange to exchange. More specifically, as discussed more fully in Chapter 6, cable had 95%+ presence in service areas covered by 48 local exchanges; 65-95% presence in the service areas covered by 816 exchanges; 30-65% presence in 293; 5%-30% in 164; and up to 5% in 4,266, at the time of this study. Overall 857 exchanges included in the first two clusters serve 45% of the delivery points in the UK (Ofcom, 2006). Therefore subscribers have a choice of more than one access platform in about one half of the downstream market and the magnitude of the risk of stranded assets varies from exchange to exchange. This suggests that the stochastic state of exchange lines and therefore the value of flexibility will vary also from exchange to exchange. Given this, a more appropriate way to structure the study is to stratify the various exchanges areas based the stochastic dynamics of the exchange lines. This is has not been done because of the lack of data.

Second, while this study assumes a representative portfolio of exchange lines through space and estimates option values from this standpoint, in practice however access seekers have the leverage to work their way through space and cherry pick high-end subscribers with high and stable demand. Clearly the distortionary effect of FL-LRIC increases, taking the analogue network as an example, if $S_{ai}(t)$ is consistently greater than $\alpha_{as}(t)$. The results from the study should therefore be seen as a conservative estimate of the distortionary effect of

FL-LRIC. Third, with respect to the ADSL platform, this research is confined to wholesale access for the 8 mbit/s end-user capacity because of the limitations on the length of this this thesis. While this capacity accounts for 43% of the UK market, this study could be extended to other capacities if this limitation was not a constraint.

Further, this study is based on the case where a third-party purchases end-to-end connectivity. It is however recognized that an access seeker may opt to purchase only subset of the network elements required to provide end-to-end connectivity, and supplement these with their own elements. Such an option results in a risk profile that differs from that studied here and presents an area for further research. The broad principles established in this study can be extended to cover such a scenario. Lastly, this study is based on data from September 1999 to July 2007 in the case of the analogue platform, and from January 2000 to December 2008, in the case of the ADSL platform. While one could argue that longer time series should have been obtained to provide a firmer basis to model the evolution of the drivers of value, it should however be noted, in the case of the former, that the length of the historical data points used in the study was limited by what is available in the public domain. In the case of the latter the length of the data points correspond to the short life so far of this relatively new platform. In mitigation, with respect to both platforms, one could argue that a regulatory lag is of a short-run duration and therefore what is required is reasonable evidence of short-run dynamics.

The study points to two directions for future research. First, studying the effect of the distortionary effect of cost-based access prices where third parties purchase only a subset of network elements required to provide end-to-end connectivity. Now while this is study is based on the case where a third-party purchases end-to-end connectivity, it is however recognized that an access seeker may opt to purchase only subset of the network elements required to provide end-to-end connectivity, and supplement these with their own elements. The second possible direction for future research is studying the effect of cost-based

access prices, if any, on the regulation of Next Generation Networks (NGNs). Now the migration from legacy to NGNs is the most significant technological transformation of telecommunication capacity networks in recent times. NGNs are a single IP-based network with distributed network intelligence and access that allows seamless access to any application in any geographic area. Unlike legacy networks which provide a series of separate products using different technology platforms, NGNs are capable of delivering multiple products (voice, data, video etc.) on a single platform. The migration is in its rudimentary stages and full deployment in European countries is expected by 2020. The migration entails considerable investment and brings with it new dimensions of risk. Substantial segments of the NGN access infrastructure will however not be readily replicable and incumbents will continue to exercise considerable market power in the access market. Third-party mandatory access to economic bottlenecks will continue to facilitate competition. The primary challenge of third-party access regulation will be to create access regimes that facilitate innovation and investment, and ultimately facilities-based competition.

Appendix A

MRP: PROOFS

The basis of the solution in Eqn 5.6 is as follows¹ - let $\chi(t) = X(t)^* - \alpha(t)$. And let

$$d\chi(t) = \gamma(\alpha(t) - \chi(t)) + \sigma dW(t) \quad (\text{A.1})$$

consider a process $\tilde{\chi}(t) = \chi(t)e^{\gamma(t-s)}$ for any $t > s$. We obtain the following using Ito's lemma

$$d\tilde{\chi}(t) = e^{\gamma(t-s)}d\chi(t) + \gamma e^{\gamma(t-s)}\chi(t)dt \quad (\text{A.2})$$

Substituting Eqn. A.1 in Eqn. A.2 we obtain

$$\begin{aligned} d\tilde{\chi}(t) &= e^{\gamma(t-s)}(\gamma\alpha dt - \gamma\chi(t)dt + \sigma dW(t) + \gamma\chi(t)dt) \\ &= e^{\gamma(t-s)}(\gamma\alpha dt + \sigma dW(t)) \end{aligned} \quad (\text{A.3})$$

From Eqn. A.3

$$\tilde{\chi}(t) = \chi(t)e^{\gamma(t-s)} = \chi(s) + \int_s^t e^{\gamma(u-s)}\gamma\alpha du + \sigma \int_s^t e^{\gamma(u-s)}dW(u) \quad (\text{A.4})$$

From Eqn. A.4, we have

$$\begin{aligned} \chi(t) &= \chi(s)e^{-\gamma(t-s)} + \\ &e^{-\gamma(t-s)} \int_s^t e^{\gamma(u-s)}\gamma\alpha du + \sigma e^{-\gamma(t-s)} \int_s^t e^{\gamma(u-s)}dW(u) \\ &= \chi(s)e^{-\gamma(t-s)} + e^{-\gamma(t-s)} \int_s^t e^{\gamma(u-s)}\gamma\alpha du + \\ &\sigma \int_s^t e^{-\gamma(t-u)}dW(u) \end{aligned} \quad (\text{A.5})$$

¹The subscript/postscript ax is henceforth dropped for clarity of exposition.

Now since

$$\int_s^t e^{\gamma u} du = \frac{1}{\gamma}(e^{\gamma(t-s)} - 1) \quad (\text{A.6})$$

We have from Eqn. A.5 and Eqn. A.6 that²

$$\chi(t) = \chi(s)e^{-\gamma(t-s)} + \alpha(1 - e^{-\gamma(t-s)}) + \sigma \int_s^t e^{-\gamma(t-u)} dW(u) \quad (\text{A.7})$$

From Eqn. A.1, the parameters we need to estimate are γ , σ and α . Now since the Ito integral $\int_s^t g(u)dW(u)$ has a Gaussian distribution $N\left(0, \int_s^t g^2(u)du\right)$, we have from Eqn. A.7,

$$\begin{aligned} \int_s^t g^2(u)du &= \int_s^t \sigma^2 e^{-2\gamma(t-u)} du \\ &= \frac{\sigma^2}{2\gamma}(1 - e^{-2\gamma(t-s)}) \end{aligned} \quad (\text{A.8})$$

We have from Eqn. A.7 that

$$E[\chi(t) | F_s] = \chi(s)e^{-\gamma(t-s)} + \alpha(1 - e^{-\gamma(t-s)}) \quad (\text{A.9})$$

And from Eqn. A.8 we have that

$$Var[\chi(t) | F_s] = \frac{\sigma^2}{2\gamma}(1 - e^{-2\gamma(t-s)}) \quad (\text{A.10})$$

And it follows from Eqn. A.9 that

$$E[X(t)^* | F_s] = (X(s)^* - \alpha(s))e^{-\gamma(t-s)} + \alpha(1 - e^{-\gamma(t-s)}) + \alpha(t) \quad (\text{A.11})$$

If we let $\widehat{\chi}(t) = \exp \chi(t)$, then from the properties of a lognormal distribu-

²See Glasserman (2004).

tion, we have³

$$\begin{aligned} Var[\widehat{\chi}(t) | F_s] = & \\ e^{2*(\chi(s)e^{-\gamma(t-s)} + \alpha(1-e^{-\gamma(t-s)})) + \frac{\sigma^2}{2\gamma}(1-e^{-2\gamma(t-s)})} * & \\ (e^{\frac{\sigma^2}{2\gamma}(1-e^{-2\gamma(t-s)})} - 1) & \end{aligned} \quad (A.12)$$

3

$$\begin{aligned} Var[\widehat{\chi}(t) | F_s] = & \\ e^{(2*E[\chi(t)|F_s] + Var[\chi(t)|F_s])} * (e^{Var[\chi(t)|F_s]} - 1) & \end{aligned}$$

Appendix B

RENEWAL THEORY: PROOFS

The probability that there are r cycles by time t is

$$P_r(t) = G_r(t) - G_{r+1}(t) \quad (\text{B.1})$$

for $r = 1$ to ∞ . The expected or average number of life cycles of an exchange line, $H^o(t)$, in the interval $[0, t]$, given an ordinary renewal process, is the weighted average of the probability of each possible occurrence during the interval.¹ $H^o(t)$, the renewal function, is equivalent to $E[P_r(t)]$ and is derived from Eqn. B.1 as follows

$$\begin{aligned} H^o(t) &= \sum_{r=0}^{\infty} r[G_r(t) - G_{r+1}(t)] \\ &= G_1(t) + G_2(t) + G_3(t) + \dots + G_{\infty}(t) \\ &= \sum_{r=1}^{\infty} G_r(t) \end{aligned} \quad (\text{B.2})$$

Therefore drawing on Eqn. B.15, the Laplace transform of $H^o(t)$ is

$$\bar{H}^o(s) = \frac{1}{s} \sum_{r=1}^{\infty} \bar{g}_r(s) \quad (\text{B.3})$$

The expression in Eqn. B.3 can be simplified, by summation to provide²

$$\bar{H}^o(s) = \frac{\bar{g}(s)}{s[1 - \bar{g}(s)]} \quad (\text{B.4})$$

For an equilibrium renewal process, because the *pdf* of the first cycle is different from that of subsequent cycles, the r -fold convolution of $\bar{g}_r(s)$ is $\bar{g}_1(s)\bar{g}(s)^{r-1}$. Therefore drawing on Eqn. B.3 above, the Laplace transform of the renewal function of a modified renewal process is

¹where $g(t)$ is a convolution of $f_0(t)$ and $f_1(t)$

²Given that $\bar{g}_r(t) = \bar{g}(t)^r$. Here $G(t)$ is the *cdf* of $g(t)$.

$$\begin{aligned}
\overline{H}^m(s) &= \frac{1}{s} \sum_{r=1}^{\infty} \overline{g}_1(s) \overline{g}(s)^{r-1} \\
&= \frac{1}{s} \sum_{r=1}^{\infty} \overline{g}_1(s) \frac{\overline{g}(s)^r}{\overline{g}(s)} \\
&= \frac{\overline{g}_1(s)}{s[1 - \overline{g}(s)]}
\end{aligned} \tag{B.5}$$

Now $h(t)$, the renewal density, is in essence a summation of the probabilities of the various discrete possible occurrences at time t . We therefore have that the renewal density for an ordinary renewal process is

$$h^o(t) = \sum_{r=1}^{\infty} g_r(t) \tag{B.6}$$

Drawing on Eqn. B.17, the Laplace transformation of the renewal density of an ordinary renewal process is

$$\overline{h}^o(s) = \sum_{r=1}^{\infty} \overline{g}_r(s) \tag{B.7}$$

Simplifying Eqn. B.7 above, we have

$$\overline{h}^o(s) = \frac{\overline{g}(s)}{1 - \overline{g}(s)} \tag{B.8}$$

Re-arranging Eqn. B.8 above we have

$$\overline{h}^o(s) = \overline{g}(s) + \overline{h}^o(s) \overline{g}(s) \tag{B.9}$$

Inverting Eqn. B.9 above, we obtain the renewal density function for an ordinary renewal process

$$h^o(t) = g(t) + \int_0^t h^o(t-u)g(u)du \tag{B.10}$$

Drawing on Eqn. B.7 and recognizing that the r -fold convolution of $g_r(s)$ for a modified renewal process is $g_1(s)g(s)^{r-1}$, we have

$$\begin{aligned}\bar{h}^m(s) &= \sum_{r=1}^{\infty} \bar{g}_1(s) \bar{g}(s)^{r-1} \\ &= \frac{\bar{g}_1(s)}{1 - \bar{g}(s)}\end{aligned}\tag{B.11}$$

The Laplace Transform is used to transform functions from the t -domain to the s -domain. To find a Laplace transform of say $f(t)$, the function is multiplied by e^{-st} and then integrated from 0 to ∞ with respect to time. The transformed function simplifies algebraic manipulation. Once manipulated the transformed expressions is reverted to the time domain. The results in B.12 to B.17 draw on Cox (1967) and Bolton (1994). Now the Laplace transform of the function $f(t)$ is

$$\mathbb{L}[f(t); s] = \bar{f}(s) = \int_0^{\infty} e^{-st} f(t) dt\tag{B.12}$$

The two most important results used in the context of renewal theory are

$$\mathbb{L} \left[\int_0^x k(u) du; s \right] = \bar{k}(s)/s\tag{B.13}$$

$$\mathbb{L} \left[\int_x^{\infty} k(u) du; s \right] = [\bar{k}(0) - \bar{k}(s)] / s\tag{B.14}$$

The above results are used to find the Laplace transform of a cdf , as shown below

$$\bar{F}(s) = \bar{f}(s)/s\tag{B.15}$$

The above results are also used to find the Laplace transform of a survivor function, as shown below

$$\bar{F}^c(s) = [1 - \bar{f}(s)] / s\tag{B.16}$$

A further useful result is

$$\mathbb{L}[f_r(t); s] = \bar{f}_r(s)\tag{B.17}$$

Appendix C

ANALOGUE: MATLAB CODES

C.1 M-File I: $S_a(t)$ Process

```

randn('state',100)% State of random variables for Sa(t)process
    Tf = [Input]; % Regulatory lag
    Nf = [Input]; % Number of time intervals in regulatory lag
    dtf = Tf/Nf; % Length of time in each interval
    tf = [0:dtf:Tf];
    M = [Input]; % Number of trajectories
    Lambda=[Input]; % Market price of risk
    GammaS= [Input]; % Speed of reversion to mean of  $\chi_a(t)$  process
    SigmaS=[Input]; % Volatility of  $\chi_a(t)$  process
    MuS=[Input]; % Mean of  $\chi_a(t)$ , chi-Process, under P
    Sa(1)=[Input]; %Log of Sa(t)at t=0
    a = [Input];% Seasonality parameter
    b = [Input];% Seasonality parameter
    c = [Input];% Seasonality parameter
    Sa2 = zeros(1,length(tf));% To initialize Sa2 - Seasonality function
    Sa2=a+b*tf+c*cos(2*pi*tf-pi/4)-(Lambda*SigmaS)/GammaS;% See Eqn. 5.57.
    Sa1 = zeros(M,length(tf));% To initialize Sa1 - Process followed by  $\chi_a(t)$ .
    Sa1(:,1) = Sa(1)-Sa2(1);% Value of Sa1 at t=0 -  $\chi_a(0)$ 
    for i=2:length(tf);
        Sa1(:,i) = Sa1(:,i-1).*exp(-GammaS*dtf)+MuS*(1-exp(-GammaS*dtf))...
            +SigmaS*sqrt((1-exp(-2*GammaS*dtf))/(2*GammaS)).*randn(M,1); % See Eqn.A.9
    and Eqn.A.10 in Appendix A
    end
    Sa3 = zeros(M,length(tf));% To initialize Sa3 - Process followed by  $\ln(Sa(t))$ 
    under risk neutral expectations
    for i=1:M
        for j=1:length(tf);
            Sa3(i,j)=Sa1(i,j)+Sa2(:,j);
        end
    end
    Sa4 = zeros(1,length(tf)-1);% Process followed by  $\ln[F(Sa(t);s,t)]$ 
    for i=2:length(tf);
        Sa4(i)=(Sa(1)-Sa2(1))*exp(-GammaS*tf(i))+Sa2(i)+((SigmaS^2)/(4*GammaS))*.....

```

```

(1-exp(-2*GammaS*tf(i)));%See Eqn. 5.60
end
Sa5 = zeros(1,length(tf)-1);% Process followed by F(Sa(t);s,t)
for i=2:length(tf);
Sa5(i)=exp(Sa4(i));
end%See Eqn. 5.60
Sa6 = zeros(M,length(tf-1));% To initialize Sa6 - Process followed by F(Sa(t);t,t)
for i=2:length(tf);
Sa6(:,i)=Sa5(i)+sqrt((exp((2*(Sa(1)-Sa2(1))*exp(-GammaS*tf(i)))+....
(((SigmaS^2)/(2*GammaS))*(1-exp(-2*GammaS*tf(i)))))*.....
(exp(((SigmaS^2)/(2*GammaS))*(1-exp(-2*GammaS*tf(i))))-1)).*randn(M,1);
end %See Eqn. A.13 in Appendix A

```

C.2 M-File II: Line Activation

```

randn('state',100)% State of random variables for Y process
Tf = [Input]; % Regulatory lag
Nf = [Input]; % Number of time intervals in regulatory lag
dtf = Tf/Nf; % Length of time in each interval
tf = [0:dtf:Tf];
M = [Input]; % Number of trajectories
Pa(1) = [Input];% Value of P-Process at t=0
Lambda=[Input];% Market Price of Risk
MuPa=[Input];% Gradient of path under P-dynamics
SigmaPa=[Input]; %Volatility of P Process
MuPa2=MuPa - (SigmaPa*Lambda);%Gradient of path under Q-dynamics
RP=[Input];%Risk Premium - UK Utilities
dW = SigmaPa*sqrt(dtf)*randn(M,Nf+1); % Increments across time
W = cumsum(dW,2); % Cumulative increments across time.
Pa = Pa(1)*exp((MuPa2- 0.5*SigmaPa^2)*repmat(tf,[M 1]) + SigmaPa*W);%
P-Process under P/Q-Dynamics
Pa2=mean(Pa,1);% Expected risk-neutral P-Process through time
Pa3=zeros(M,length(tf));%Initializing PT
for i=1:length(tf);
Pa3(:,i)=(rand(M,1)<=Pa2(i));% Bernouli Process - Pt(i)
end

```

C.3 M-File III: Contingent Claim Valuation

```

RF=[Input]; %Risk-free rate of interest
K=[Input];%Price of access to Subscriber Network
Tf = [Input]; % Regulatory lag
Nf = [Input]; % Number of time intervals in regulatory lag
dtf = Tf/Nf; % Length of time in each interval
tf = [0:dtf:Tf];
M = [Input]; % Number of trajectories
Sa7 = zeros(M,length(tf));% To initialize Sa7 - Payoffs on F(Sa(t);t,t)
for i=1:M
    for j=1:length(tf)
        if Sa6(i,j)-K>0
            Sa7(i,j)=Sa6(i,j)-K;
        else
            Sa7(i,j)=0;
        end;
    end;
end;
Sa8 = zeros(M,length(tf));% To initialize Sa8 - Payoffs on F(Sa(t);t,t) incorpo-
rating the effect of the intensity of activation.
for i=1:M
    for j=1:length(tf)
        Sa8(i,j)=Sa7(i,j)*Pa(i,j);
    end
end
Sa9 = zeros(M,length(tf));% To initialize Sa10 - Discounted value of pay-offs on
F(Sa(t);t,t).
for i=1:M
    for j=1:length(tf)
        Sa9(i,j)=Sa8(i,j).*exp(-tf(j)*RF);
    end
end
Sa10=mean(Sa9,1);% Mean per period option value
Sa11=cumsum(Sa10,2);%Option value per blocks of time [*]
K2 = zeros(1,length(tf));%To initialize K2
for i=1:length(tf)
    K2(i)=K.*exp(-tf(i)*RF);%Discounted value of regulated access price

```

```

end
K3=cumsum(K2,2);% Value of regulated access price for blocks of time[*]
for i=1:length(tf)
SD(i)=std(Sa9(:,i));% Standard deviation of options values.[*]
end
for i=1:length(tf)
SE(i)=SD(i)/(sqrt(M));% Standard error of options values.[*]
end

```

C.4 M-File IV: Parameter Estimation - $S_a(t)$

```

global PARMIN PARMAX;
PARMIN = [0.0001 0.0001]; %
PARMAX = [5 5];
initial=[0.5 0.5]; % Initial Estimates [0.5 0.5 2]
options=optimset('maxfunevals',20000, 'maxiter',5000,'TolFun',1.e-4,'TolX',1.e-4,'Display','iter');
[values, fval, exitflag] = fminsearch(@mlemrp,initial,options)
function x = mlemrp(param)
global PARMIN PARMAX;
T = [Input]; % Regulatory lag
N = [Input]; % Number of time intervals in regulatory lag
dt = T/N; % Length of time in each interval
t = [0:dt:7.5];% Time intervals in regulatory lag
MuS=0;
S1=[Data];
GammaS=param(1);% Speed of reversion to mean
SigmaS=param(2);% Volatility of log of S(t) process
for(p=1:length(param))
if(param(p)<PARMIN(p) | param(p)>PARMAX(p))
x = 1e+32;
return
end
end
SS=zeros(n-1,1); % To accommodate n-1 transition densities
for i=2:n
SS(i-1)=-.5*log((SigmaS^2)/(2*GammaS))- .5*log(1-exp(-2*GammaS*dt)) -.....
(GammaS/SigmaS^2)*((S1(i) - MuS-(S1(i-1)- MuS)*exp(-GammaS*dt))^2)/.....
(1-exp(-2*GammaS*dt));
end % Maximum Likelihood Estimation - See Eqn. 5.46

```

```
x= - sum(SS);% Minimizing negative function
```

C.5 M-File V: Parameter Estimation - $\rho_a(t)$

```
global PARMIN PARMAX;
    initial=[0.1 0.1 ];
    PARMIN = [0 0];
    PARMAX = [10 2];
    options=optimset('maxfunevals',20000, 'maxiter',1000,'TolFun',1.e-4,'TolX',1.e-4,'Display','iter');
    [values, fval, exitflag] = fminsearch(@mlegbm,initial,options)
    global PARMIN PARMAX;
    sigma=param(1);
    mu=param(2);
    for(p=1:length(param))
    if(param(p)<PARMIN(p) | param(p)>PARMAX(p))
    x = 1e+32;
    return
    end
    end
    Z=[Data];
    Z1=log(Z);
    n=length(Z1);
    V=zeros(n-1,1); % There are n-1 transition densities
    dt=1;
    for i=2:n
    V(i-1)=-.5*(log(2*pi*sigma^2*dt) + (Z1(i) - Z1(i-1)-(mu-.5*sigma^2)*dt)^2/(sigma^2*dt))
    ; % See Equation 5.48
    end
    for i=2:n
    Z3(i)=log(Z(i));
    end
    loglikelihood = sum(V) + log(1/sqrt(2*pi*sigma^2)*exp(-(Z1(1)-mu)^2)/(2*sigma^2))
- sum(Z3);
    x= - loglikelihood; % the negative log-likelihood
```

Appendix D

ADSL: MATLAB CODES

D.1 M-File I: $S_b(t)$ Process

```

randn('state',100)% State of random variables for Sb(t)process
    Tfb = [Input]; % Regulatory lag
    Nfb = [Input]; % Number of time intervals in regulatory lag
    dtfb = Tfb/Nfb; % Length of time in each interval
    tfb = [0:dtfb:Tfb];
    Mb = [Input]; % Number of trajectories
    Lambda=[Input]; % Market price of risk
    GammaSb=[Input]; % lnSb(t) - Speed of reversion to mean
    SigmaSb=[Input]; % lnSb(t) - Volatility
    MuSb=[Input]; % lnSb(t)- Mean under P
    MuSb2=MuSb-Lambda*(SigmaSb/GammaSb);% lnSb(t)- Mean under Q
    Sb=[Input]; %lnSb(t) at t=0

    Sb1 = zeros(Mb,length(tfb));% To initialize Sb1 - Process followed by lnSb(t)
    Sb1(:,1) = Sb;% lnSb(t) at t=0
    for i=2:length(tfb);
        Sb1(:,i) = Sb1(:,i-1).*exp(-GammaSb*dtfb)+MuSb2*(1-exp(-GammaSb*dtfb))...
            +SigmaSb*sqrt((1-exp(-2*GammaSb*dtfb))/(2*GammaSb)).*randn(Mb,1); %
See Eqn. A.11 and Eqn. A.12 in Appendix A.
    end
    Sb2 = zeros(1,length(tfb));% To initialize Sb2 - Process followed by ln(F(Sb(t),t,s))
    for i=2:length(tfb);
        Sb2(i)=Sb*exp(-GammaSb*(tfb(i)-tfb(1)))+ MuSb2*(1-exp(-GammaSb*tfb(i)))+...
            +(1/4)*((SigmaSb^2)/(4*GammaSb))*(1-exp(-2*GammaSb*tfb(i)));
    end
    %See Eqn. 6.12
    Sb3 = zeros(1,length(tfb));% Process followed by F(Sb(t),t,s)
    for i=2:length(tfb);
        Sb3(i)=exp(Sb2(i));
    end%See Eqn. 5.61
    Sb4 = zeros(Mb,length(tfb));% To initialize Sb4 - Process followed by F(Sb(t);t,t)
    for i=2:length(tfb);
        Sb4(:,i)=Sb3(i)+sqrt(exp((2* Sb*exp(-GammaSb*tfb(i))+MuSb2*.....

```

```

(1-exp(-GammaSb*tfb(i)))+(SigmaSb^2)/(2*GammaSb))* (1- exp(-2*GammaSb*.....
tfb(i)))*((exp(((SigmaSb^2)/(2*GammaSb))*.....
(1- exp(-2*GammaSb*tfb(i))))-1)).*randn(Mb,1);
end %See Eqn. A.12 in Appendix A

```

D.2 M-File II: Line Activation

```

randn('state',100)% State of random variables for Pb(t) process
Tfb = [Input]; % Regulatory lag
Nfb = [Input]; % Number of time intervals in regulatory lag
dtfb = Tfb/Nfb; % Length of time in each interval
tfb = [0:dtfb:Tfb];
Mb = [Input]; % Number of trajectories
RP=[Input];%Risk Premium - UK Utilities
Pb(1)=[Input];% Value of Pb(t) at t=0
Lambda=[Input];% Market Price of Risk
MuPb=[Input];% Gradient of path under P-dynamics
SigmaPb=[Input]; %Volatility of Pb(t)
MuPb2=MuPa-(SigmaPa*Lambda);%Gradient of path under Q-dynamics - See
Eqn. 6.25 and Eqn. 6.29
dW = SigmaPb*sqrt(dtfb)*randn(Mb,Nfb+1); % Increments across time
W = cumsum(dW,2); % Cumulative increments across time.
Pb = Pb(1)*exp((MuPb2- 0.5*SigmaPb^2)*repmat(tfb,[Mb 1]) + SigmaPb*W);%
Pb(t) under P/Q-Dynamics
Pb2=mean(Pb,1);% Expected risk-neutral Pb(t)through time
Pb3=zeros(M,length(tf));%Initializing - Bernouli Process
for i=1:length(tfb);
Pb3(:,i)=(rand(Mb,1)<=Pb2(i));% Bernouli Process - Pt(i)
end

```

D.3 M-File III: Contingent Claim Valuation

```

RF=[Input]; %Risk-free rate of interest
Kb=[Input];%Price of access to Subscriber Network
Tfb = [Input]; % Regulatory lag
Nfb = [Input]; % Number of time intervals in regulatory lag
dtfb = Tfb/Nfb; % Length of time in each interval
tfb = [0:dtfb:Tfb];

```

```

Mb = [Input]; % Number of trajectories
Sb7 = zeros(Mb,length(tfb));% To initialize Sb7 - Payoffs on ln(Sb(t);t,t) under
risk-neutral expectations
for i=1:Mb
Sb5 = zeros(Mb,length(tfb));% To initialize Sb5 - Payoffs on F(Sb(t);t,t)
for i=1:Mb
for j=1:length(tfb)
if Sb4(i,j)-Kb>0
Sb5(i,j)=Sb4(i,j)-Kb;
else
Sb5(i,j)=0;
end;
end;
end;
Sb6 = zeros(Mb,length(tfb));% To initialize Sb6 - Payoffs on F(Sb(t);t,t) incor-
porating the effect of the intensity of activation.
for i=1:Mb
for j=1:length(tfb)
Sb6(i,j)=Sb5(i,j)*Pb(i,j);
end
end
Sb7 = zeros(Mb,length(tfb));% To initialize Sb7 - Discounted value of pay-offs
on Sb(t)under risk-neutral expectations
for i=1:Mb
for j=1:length(tfb)
Sb7(i,j)=Sb6(i,j).*exp(-tfb(j)*RF);
end
end
Sb8=mean(Sb7,1);% Mean per period option value
Sb9=cumsum(Sb8,2);%Option value per blocks of time [*]
K2 = zeros(1,length(tfb));%To initialize K2
for i=1:length(tfb)
K2(i)=Kb.*exp(-tfb(i)*RF);%Discounted value of regulated access price
end
K3=cumsum(K2,2);% Value of regulated access price for blocks of time[*]
for i=1:length(tfb)
SD(i)=std(Sb7(:,i));% Standard deviation of options values.[*]
end
for i=1:length(tfb)

```



```
SE(i)=SD(i)/(sqrt(Mb));% Standard error of options values.[*]
end
```

D.4 M-File IV: Parameter Estimation - $S_b(t)$

```
global PARMIN PARMAX;
  PARMIN = [0.001 0.001 0.001]; % Upper Limit for each of the 3 parameters
  [0.001 0.001 0.001]
  PARMAX = [5 5 20]; % Lower Limit for each of the 3 parameters[5 5 20]
  initial=[0.5 0.5 2]; % Initial Estimates [0.5 0.5 2]
  options=optimset('maxfunvals',20000, 'maxiter',5000,'TolFun',1.e-4,'TolX',1.e-4,'Display','iter');
  [values, fval, exitflag] = fminsearch(@mlemrp,initial,options)
  function x = mlemrp(param)
  global PARMIN PARMAX;
  Tb = [Input]; % Regulatory lag
  Nb = [Input]; % Number of time intervals in regulatory lag
  dtb = Tb/Nb; % Length of time in each interval
  tb = [0:dtb:7.5];% Time intervals in regulatory lag
  S1b=[Input];%ln(Net Downstream Value)
  n=length(S1b);
  GammaSb=param(1);% lnSb(t) - Speed of reversion to mean
  SigmaSb=param(2);% lnSb(t) - Volatility of
  MuSb=param(3);% lnSb(t) - Level at which lnSb(t)fluctuates
  for(p=1:length(param))
  if(param(p)<PARMIN(p) | param(p)>PARMAX(p))
  x = 1e+32;
  return
  end
  end
  SSb=zeros(n-1,1); % To accommodate n-1 transition densities
  for i=2:n
  SSb(i-1)=-.5*log((SigmaSb^2)/(2*GammaSb))- .5*log(1-exp(-2*GammaSb*dtb))
  - (GammaSb/SigmaSb^2)*((S1b(i) - MuSb-(S1b(i-1)- MuSb)*exp(-GammaSb*dtb))^2)/(1-
  exp(-2*GammaSb*dtb));
  end % Maximum Likeliwood Estimation - See Eqn.6.36
  x= - sum(SSb);% Minimizing negative function£
```

Appendix E

DATA

Year	Qtr.	Traffic/ Line/			Traffic/ Line/			Traffic/ Line/			Traffic/ Line/									
		Month	Year	Qtr	Month	Year	Qtr	Month	Year	Qtr	Month	Year	Qtr	Month						
1999	4	326.21						303.13						315.59	2006	1	304.16			
		322.26						2004	1	317.19				297.98						
		318.31	2002	1	302.44					310.49				291.80						
2000	1	314.36						299.33						303.79	2	2	285.63			
		309.95								297.09				286.83						
		305.54		2	293.12					297.42				288.03						
	2	301.13							289.60					297.75	3	3	289.24			
			299.35								286.09		3	298.08			291.29			
		297.57		3	282.57					302.85				293.35						
		295.80							288.66					307.62	4	4	295.41			
	301.86								294.75		4	312.40	291.92							
	307.92		4	300.85					311.43					288.42						
	4	313.98							299.97					310.46	2007	1	284.93			
			313.91								299.10	2005	1	309.48			277.36			
			313.85	2003	1	298.23					305.60						269.79			
2001	1	313.79						294.16					301.72	2	2	262.23				
		308.49								290.09						297.84	260.02			
		303.20		2	286.02					294.95						257.81				
	2	297.90							287.53					292.06	3	3	292.06			
			297.60								289.05						289.17	2007	3	289.17
			297.29		3	290.57					294.83						294.83			
	3	296.99							297.84					300.50	4	4	300.50			
			299.15								305.11						306.16			
		301.31		4	312.37					305.50				305.50						
		303.47								313.98				304.83						

Source: Ofcom - Market Data Tables

Table E.1: Analogue - Monthly Average Traffic/Exchange Line - Minutes

Exchange			Exchange			Exchange			Exchange		
Year	Qtr.	Lines	Year	Qtr	Lines	Year	Qtr	Lines	Year	Qtr	Lines
1999	4	20,082	2002	1	20,028	2004	2	19,748	2006	3	16,868
		20,066			20,037			19,720			16,829
		20,051			20,047			19,691			16,789
2000	1	20,035		2	20,056		3	19,663		4	16,750
		20,021			20,051			19,643			16,711
		20,007			20,047			19,622			16,673
	2	19,993		3	20,042		4	19,602	2007	1	16,634
		19,975			20,057			19,573			16,585
		19,958			20,071			19,545			16,536
	3	19,940		4	20,086	2005	1	19,516		2	16,487
		19,937			20,077			19,402			16,407
		19,935			20,069			19,289			16,328
	4	19,932	2003	1	20,060		2	19,175			
		19,944			20,037			19,041			
		19,957			20,014			18,906			
2001	1	19,969		2	19,991		3	18,772			
		19,971			19,973			18,654			
		19,974			19,956			18,537			
	2	19,976		3	19,938		4	18,419			
		19,933			19,932			18,249			
		19,889			19,926			18,079			
	3	19,846		4	19,920	2006	1	17,909			
		19,910			19,842			17,692			
		19,974			19,763			17,475			
	4	20,038		1	19,685		2	17,258			
		20,035			19,706			17,128			
		20,031			19,727			16,998			

Source: Ofcom - Market Data Tables

Table E.2: Analogue - Active Residential Exchange Lines in BT's Infrastructure (000s)

Year	Qtr.	Estimated			Year	Qtr	Estimated			Year	Qtr	Estimated		
		Year	Qtr	Utilisation			Year	Qtr	Utilisation			Year	Qtr	Utilisation
1999	4	91.55%	2002	1	91.2%	2004	2	90.0%	2006	3	76.8%			
		91.4%			91.3%			89.8%			76.7%			
		91.3%			91.3%			89.7%			76.5%			
2000	1	91.3%	2	3	4	89.6%	89.5%	89.4%	2007	1	75.8%			
		91.2%										91.4%	89.5%	76.1%
		91.1%										91.3%	89.4%	76.0%
	2	3	4	89.3%	89.2%	89.0%	75.3%							
								91.0%	91.4%	89.2%	75.6%			
								90.9%	91.4%	89.0%	75.3%			
	3	4	2005	1	88.9%	2	75.3%							
								90.8%	91.5%	88.4%	75.1%			
								90.8%	91.4%	87.9%	74.7%			
	2001	4	2003	1	2	87.4%	86.7%	86.1%						
									90.8%	91.3%	86.7%			
									90.9%	91.2%	86.1%			
1		2	3	85.5%	85.0%	84.4%								
							91.0%	91.0%	85.0%					
							91.0%	90.9%	84.4%					
2	3	4	83.9%	83.1%	82.4%									
						91.0%	90.8%	83.9%						
						90.8%	90.8%	83.1%						
3	4	2006	1	81.6%	80.6%	79.6%								
							90.4%	90.8%	81.6%					
							90.7%	90.4%	80.6%					
4	2004	1	2	78.6%	78.0%	77.4%								
							91.3%	89.7%	78.6%					
							91.3%	89.8%	78.0%					

Table E.3: Analogue - Estimated Activation (BT's Residential Exchange Lines)

Year	Qtr.	Tariff/ Month	Year	Qtr	Tariff/ Month	Year	Qtr	Tariff/ Month	Year	Qtr	Tariff/ Month
2000	1	60.49			50.49			30.49			28.49
		60.49		2	50.49		3	30.49	2007	1	30.32
		60.49			50.49			29.82			30.32
	2	60.49			50.49			29.16			30.30
		60.49		3	40.49		4	28.49		2	29.82
		60.49			40.49			28.49			29.83
	3	60.49			40.49			28.49			29.83
		60.49		4	40.49	2005	1	28.49		3	29.83
		60.49			40.49			28.49			29.83
	4	60.49			40.49			28.49			29.83
		60.49		1	37.50		2	28.49		4	29.83
		60.49			37.50			28.49			29.66
2001	1	50.49			37.50			28.49			29.66
		50.49		2	37.50		3	28.49	2008	1	29.65
		50.49			37.50			28.49			29.27
	2	50.49			37.50			28.49			28.96
		50.49		3	40.49		4	28.49		2	28.28
		50.49			40.49			28.49			28.19
	3	50.49			40.49			28.49			28.19
		50.49		4	37.50	2006	1	28.49		3	29.19
		50.49			37.50			28.49			28.19
	4	50.49			37.50			28.49			28.19
		50.49	2004	1	37.50		2	28.49		4	28.20
		50.49			37.50			28.49			28.20
		50.49			37.5			28.49			28.20
2002	1	50.49		2	30.49		3	28.49			
		50.49			30.49			28.49			

Source: Point Topic and Pure Pricing

Table E.4: ADSL - Average Headline Tariffs (8 mbit/s)

		BT	Orange	Pipex	O2	Tiscali	Toucan	Virgin	Plus Net
2007	January	28.99	30.99	30.99	-	28.99	28.99	-	32.99
	February	28.99	26.49	30.99	-	28.99	28.99	-	32.99
	March	28.99	26.49	30.99	-	28.99	28.99	-	32.99
	April	28.99	26.49	30.99	-	28.99	28.99	28.99	32.99
	May	28.99	26.49	30.99	-	28.99	28.99	28.99	30.99
	June	28.99	26.49	30.99	-	28.99	28.99	28.99	30.99
	July	28.99	26.49	30.99	-	28.99	28.99	28.99	30.99
	August	28.99	26.49	30.99	-	28.99	28.99	28.99	30.99
	September	28.99	26.49	30.99	-	28.99	28.99	28.99	30.99
	October	28.99	31.00	30.99	-	28.99	28.99	28.99	30.99
	November	28.99	31.00	30.99	28.50	28.99	28.99	28.99	30.99
	December	28.99	31.00	30.99	28.50	28.99	28.99	28.99	30.99
2008	January	28.99	31.00	30.99	28.50	28.99	28.99	28.99	30.99
	February	28.99	31.00	30.99	28.00	25.99	28.99	28.99	30.99
	March	28.99	31.00	30.99	28.00	25.99	28.99	-	30.99
	April	26.49	30.50	-	28.00	25.49	28.49	-	30.49
	May	26.49	30.50	-	28.00	25.49	28.49	-	30.49
	June	26.49	30.50	-	28.00	25.49	28.49	-	30.49
	July	26.49	30.50	-	28.00	25.49	28.49	-	30.49
	August	26.49	30.50	-	28.00	25.49	28.49	-	30.49
	September	26.49	30.50	-	28.00	25.49	28.49	-	30.49
	October	26.49	30.50	-	28.00	25.49	28.49	-	30.49
	November	26.49	30.50	-	28.00	25.49	28.49	-	30.49
	December	26.49	30.50	-	28.00	25.49	28.49	-	30.49

Source: Pure Pricing Database (www.purepricing.com)

Table E.5: ADSL - Headline Tariffs from Service Providers (8 mbit/s)

									Plus
		BT	Orange	Pipex	02	Tiscali	Toucan	Virgin	Net
2007	January	2.88%	-	-	-	-	-	-	7.88%
	February	2.88%	-	-	-	-	-	-	7.88%
	March	2.88%	-	-	-	-	-	-	7.88%
	April	2.97%	-	-	-	-	-	-	7.88%
	May	2.97%	-	5.27%	-	-	-	-	8.05%
	June	2.97%	-	-	-	-	-	-	8.05%
	July	2.97%	-	-	-	-	-	-	8.05%
	August	2.97%	2.42%	-	-	-	-	-	8.05%
	September	2.97%	2.42%	-	-	-	-	-	8.05%
	October	2.97%	-	-	-	-	-	-	8.05%
	November	2.97%	-	-	7.95%	-	-	-	8.05%
	December	2.97%	-	-	7.95%	-	-	-	8.05%
2008	January	2.97%	-	-	9.12%	5.86%	-	-	8.05%
	February	2.97%	-	-	9.12%	4.23%	-	-	8.05%
	March	2.97%	-	-	9.12%	4.23%	-	-	8.05%
	April	1.26%	-	-	9.12%	5.39%	-	-	8.05%
	May	1.26%	6.56%	-	7.95%	5.39%	-	-	8.05%
	June	1.76%	6.56%	-	7.95%	6.93%	-	-	8.05%
	July	1.76%	6.56%	-	7.95%	6.93%	-	-	8.05%
	August	1.26%	6.56%	-	7.95%	6.93%	-	-	8.05%
	September	1.26%	6.56%	-	7.95%	6.93%	-	-	8.05%
	October	1.26%	-	-	7.95%	6.93%	-	-	8.05%
	November	1.26%	-	-	7.95%	6.93%	-	-	8.05%
	December	1.26%	-	-	7.95%	6.93%	-	-	8.05%

Source: Computed from Pure Pricing Database

Table E.6: ADSL - 8Mbit/s, Indicative Headline Promotional Discounts

Capacity				
Mbit/s	Local	Regional	National	Handover
0.25	325	475	590	295
0.5	450	660	815	410
1	700	1,025	1,270	635
2	1,200	1,750	2,180	1090
3	1,700	2,475	3,090	1,545
4	2,200	3,200	4,000	2,000
5	2,700	3,925	4,910	2,455
6	3,200	4,650	5,820	2,910
7	3,700	5,375	6,730	3,365
8	4,200	6,100	7,640	3,820
9	2,200	3,200	8,400	2,000
10	5,200	7,550	9,460	4,730
12	6,200	9,000	11,280	5,640
14	7,200	10,450	13,100	6,550
16	8,200	11,900	14,920	7,460
18	9,200	13,350	16,740	8,370
20	10,200	14,800	18,560	9,280
22	11,200	16,250	20,380	10,190
24	12,200	17,700	22,200	11,100
26	13,200	19,150	24,020	12,010
28	14,200	20,600	25,840	12,920
30	15,200	22,050	27,660	13,830
32	16,200	23,500	29,480	14,740
34	17,200	24,950	31,300	15,650

Source: BT - Broadband Wholesale Services

Table E.7: Price Per VP/annum (£) - VBnrt

Capacity				
Mbit/s	Local	Regional	National	Handover
0.25	351	513	638	319
0.5	486	713	880	443
1	756	1,107	1,372	686
2	1,296	1,890	2,354	1,177
3	1,836	2,673	3,337	1,669
4	2,376	3,456	4,320	2,160
5	2,916	4,236	5,303	2,651
6	3,456	5,022	6,286	3,143
7	3,996	5,806	7,268	3,634
8	4,536	6,588	8,251	4,126
9	5,076	7,371	9,234	4,617
10	5,616	8,154	10,217	5,108

Source: BT - Wholesale Broadband Services

Table E.8: Price per VP/annum (£) - VBrt

Capacity				
Mbit/s	Local	Regional	National	Handover
0.25	358	523	649	325
0.5	495	726	897	451
1	770	1,128	1,397	699
2	1,320	1,925	2,398	1,199
3	1,870	2,723	3,399	1,700
4	2,420	3,520	4,400	2,200
5	2,970	4,318	5,401	2,701
6	3,520	5,115	6,402	3,201
7	4,070	5,913	7,402	3,702
8	4,620	6,710	8,404	4,202
9	5,170	7,508	9,405	4,703
10	5,720	8,305	10,406	5,203

Source: BT - Wholesale Broadband Services

Table E.9: Price Per VP/annum (£) - CBR

Capacity		
Mbit/s	Connection	Rental
0.5	34.86	84.60
1	34.86	84.60
2	34.86	84.60
DataStream Max	34.86	84.60
DataStream Premium	34.86	84.60

Source: BT - Broadband Wholesale Services

Table E.10: ADSL - Ender-User Access Charges (£)

Capacity			
Mbit/s	Connection	Rental	Booking Ratio
155	2,000	50,000	100%
155	2,000	50,000	200%
155	2,000	50,000	300%
155	2,000	50,000	400%
622	4,000	175,000	100%

Source: BT - Broadband Wholesale Services

Table E.11: ADSL - Customer Access Link Charges (£)

	Local Exchange Processor	Main Exchange Switching	Local- Tandem Switch	Local- Tandem Transmission	Local Tandem Switch	Inter- Tandem Length	Traffic Mix
Unit Cost (£)	0.107	0.048	0.026	0.018	0.037	0.003	
Useage Factors							
Local Calls	1.860	0.170	1.787	24.850	0.151	7.299	61%
National Calls	1.949	1.584	1.768	27.803	1.501	164.896	26%
Calls to Mobiles	1.016	1.441	1.272	16.731	0.401	25.172	10%
International Calls	1.026	0.917	1.034	10.880	0.345	24.034	4%

Source: BT - Current Cost Financial Statements

Table E.12: Analogue - Conveyance Charges and Useage Factors

Appendix F

ADSL: DISTRIBUTION OF EXCHANGE LINES

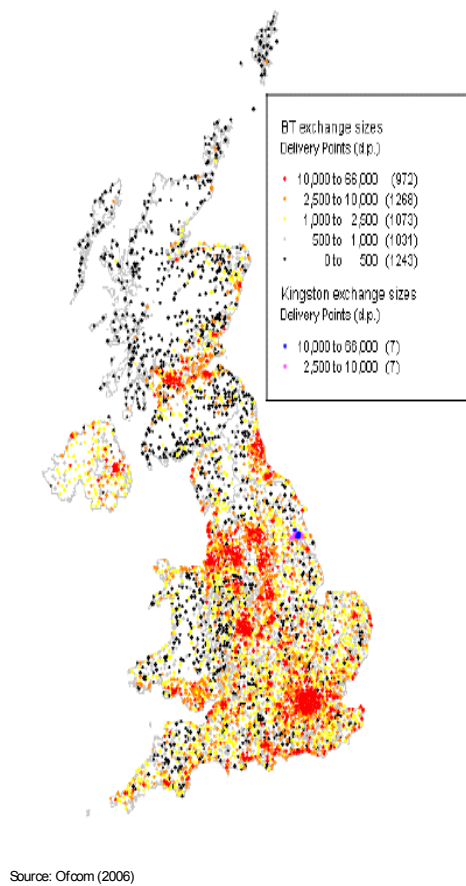
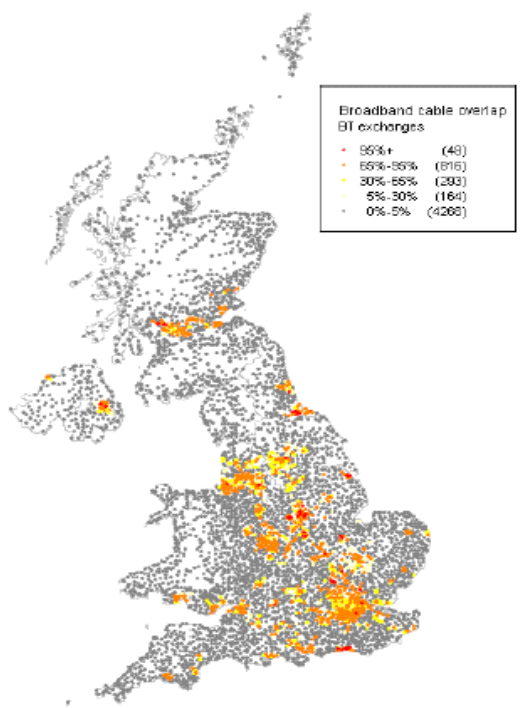

Figure F.1: Local Exchanges by Size



Source: Ofcom (2006)

Figure F.2: ADSL and Cable Overlap

BIBLIOGRAPHY

- [1] Acton, J. P., & Vogelsang, I. (1989). Introduction to Price Caps Symposium. *Rand Journal of Economics*, 20(3), 369-372.
- [2] Aizu, I. (2002). A Comparative Study of Broadband in Asia: Deployment and Policy (Report to Asia Network Research and GLOCOM). Tokyo, Japan.
- [3] Akat, M., de Alemedia, C. I. R., & Papanicolaou, G. (2006). Pricing and Modelling Credit Derivatives. Working Paper, Carnegie Mellon University and Stanford University.
- [4] Alaton, P., Djehiche, B., & Stillberger, D. (2002). On Modelling and Pricing Weather Derivatives. *Applied Mathematical Finance*, 9(1), 1-20.
- [5] Alleman, J. (2002). A New View of Telecommunications Economics. *Telecommunications Policy*, 26(1-2), 87-92.
- [6] Alleman, J., & Rappoport, P. (2002). Modelling Regulatory Distortions with Real Options. *Engineering Economist*, 47(4), 390-417.
- [7] Alleman, J., & Rappoport, P. (2005). Regulatory Failure: Time for a New Policy Paradigm. *Communications and Strategies*, 60(4), 105-121.
- [8] Alleman, J., & Rappoport, P. (2006). Optimal Pricing with Sunk Costs and Uncertainty. In R. Cooper, A. Lloyd, G. Madden & M. Schipp (Eds.), *The Economics of Online Markets and ICT Networks*. New York: Physica-Verlag, Heidelberg, Chapter 9.
- [9] Analysys. (2005). Cost of the BT UK Local Loop Network (Report to Ofcom). London.
- [10] Armstrong, M. (2002). The Theory of Access Pricing and Interconnection. In M. Cave, S. Majumdar & I. Vogelsang (Eds.), *Handbook of Telecommunications Economics*. Amsterdam: Elsevier, Chapter 9.
- [11] Aron, D. J., & Burnstein, D. E. (2003). Broadband Adoption in the United States: An Empirical Analysis. SSRN Working Paper Series.
- [12] Audet, N., Heiskanen, P., Keppo, J., & Vehvilainen, I. (2004). Modelling Electricity Forward Curve Dynamics in the Nordic Market In D. W. Bunn (Ed.), *Modelling Prices in Competitive Electricity Markets*. Sussex: Wiley, 251-265.

- [13] Averch, J., & Johnson, L. L. (1962). Behaviour of the Firm Under Regulatory Constraints. *American Economic Review*, 52(5), 1052-1069.
- [14] Barlow, M. (2002). A Diffusion Model for Electricity Prices. *Mathematical Finance* 12(4), 287-298.
- [15] Barraquand, J. (1995). Numerical Valuation of High Dimensional Multivariate European Securities. *Management Science*, 41(12), 1882-1891.
- [16] Barraquand, J., & Martineau, D. (1995). Numerical Valuation of High Dimensional Multivariate American Securities. *Journal of Financial and Quantitative Analysis*, 30(3), 383-405.
- [17] Bauer, J. M. (2005). Unbundling Policy in the United States: Players, Outcomes and Effects Working Paper, Quello Centre for Telecommunication Management and Law, Michigan State University.
- [18] Baumol, W., & Sidak, J. G. (1994). The Pricing of Inputs Sold To Competitors. *Yale Journal on Regulation*, 11(1), 171-202.
- [19] Baumol, W. J., & Bradford, D. F. (1970). Optimal Departures from Marginal Cost Pricing. *American Economic Review*, 60(3), 265-283.
- [20] Baumol, W. J., Ordovery, J. A., & Willig, R. D. (1997). Parity Pricing and Its Critics: A Necessary Condition for Efficiency in Provision of Bottleneck Services to Competitors. *Yale Journal on Regulation*, 14(1), 145-163.
- [21] Baumol, W. J., & Sidak, J. G. (1994). *Toward Competition in Local Telephone*. Cambridge, MA: MIT Press.
- [22] Beard, T. R., Kaserman, D. L., & Mayo, J. W. (1998). The Role of Resale Entry in Promoting Local Exchange Competition. *Telecommunications Policy*, 22(4-5), 315-326.
- [23] Benth, F. E. (2003). Arbitrage-free Pricing of Weather Derivatives Based on Fractional Brownian Motion. *Applied Mathematical Finance*, 10(4), 303-324.
- [24] Benth, F. E., & Benth, J. S. (2007). Stochastic Modelling of Temperature Variations with a View Towards Weather Derivatives. *Applied Mathematical Finance*, 12(1), 53-85.

- [25] Benth, F. E., & Benth, J. S. (2007). The Volatility of Temperature and Pricing of Weather Derivatives. *Quantitative Finance*, 7(5), 553-561.
- [26] Benth, F. E., Benth, J. S., & Koekebakker, S. (2007). Putting a Price on Temperature. *Scandinavian Journal of Statistics*, 34(4), 746-767.
- [27] Benth, F. E., Ekeland, L., Hauge, R., & Nielsen, B. F. (2003). On Arbitrage-free Pricing of Forward Contracts in Energy Markets. *Applied Mathematical Finance*, 10(4), 325-336.
- [28] Bielecki, T., & Rutkowski, M. (2000). Credit Risk Modelling: Intensity Based Approach. Working Paper, Department of Mathematics, North-Eastern Illinois University.
- [29] Bingham, N. H., & Kiesel, R. (2004). *Risk-neutral Valuation : Pricing and Hedging of Financial Derivatives* (2nd ed.). London: Springer.
- [30] Black, F. (1976). The Pricing of Commodity Contracts. *Journal of Financial Economics*, 3(1-2), 167-179.
- [31] Black, F., & Cox, J. (1976). Valuing Corporate Securities: Some Effects of Bond Indenture Provisions. *Journal of Finance* 31(2), 351-367.
- [32] Black, F., & Scholes, M. (1973). The Pricing of Options and Corporate Liabilities. *Journal of Political Economy*, 81(3), 637-654.
- [33] Bluhm, C., Overbeck, L., & Wagner, C. (2003). *An Introduction to Credit Risk Modelling*. Boca Raton, Fla.: Chapman Hall.
- [34] Bollen, N. P. (1997). Derivatives and the Price of Risk. *Journal of Futures Markets*, 17(7), 839-854.
- [35] Bolton, W. (1994). *Laplace and Z-transforms*. Harlow: Longman.
- [36] Bork, R. H. (1993). *The Antitrust Paradox: A Policy at War with Itself*. New York: Free Press.
- [37] Boyle, P. (1977). Options: A Monte Carlo Approach. *Journal of Financial Economics*, 4(3), 323-338.
- [38] Boyle, P., Broadie, M., & Glasserman, P. (1997). Monte Carlo Methods for Security Pricing. *Journal of Economic Dynamics and Control*, 21(8-9), 1267-1321.

- [39] Brekke, K. A., & Schieldrop, B. (2000). Investment in Flexible Technologies under Uncertainty. In M. J. Brennan & L. Trigeorgis (Eds.), *Project Flexibility, Agency, and Competition: New Developments in the Theory and Application of Real Options*. New York: Oxford University Press. Chapter 3
- [40] Bremaud, P. (1981). *Point Processes and Queues* (2nd ed.). New York: Springer Verlag.
- [41] Brennan, M. J., & Schwartz, E. S. (1985). Evaluating Natural Resource Investments. *Journal of Business*, 58(2), 135–157.
- [42] Brennan, T. (1989). Regulating by Capping Prices. *Journal of Regulatory Economics*, 1(2), 133-147.
- [43] British Telecommunications. (2005). Facts about Local Loop Unbundling. London.
- [44] Broadie, M., & Glasserman, P. (1997). Pricing American-style Securities using Simulation. *Journal of Economic Dynamics and Control*, 21(8-9), 1323-1352.
- [45] Broadie, M., Glasserman, P., & Gautam, J. (1997). Enhanced Monte Carlo Estimates for American Option Prices. *Journal of Derivatives*, 5(1), 25-44.
- [46] Brody, D. C., Syroka, J., & Zervos, M. (2002). Dynamical Pricing of Weather Derivatives. *Quantitative Finance*, 2(3), 89-198.
- [47] Brown, L., Einhorn, M., & Vogelsang, I. (1989). *Incentive Regulation: A Research Report* (Report to Office of Economic Policy, Federal Energy Regulatory Commission). Washington D.C.
- [48] Burger, M., Klar, B., Muller, A., & Schindlmayr, G. (2004). A Spot Market Model for Pricing Derivatives in Electricity Markets. *Quantitative Finance*, 4(1), 109-122.
- [49] Campbell, J. Y., & Thompson, S. B. (2005). *Predicting the Equity Premium Out of Sample: Can Anything Beat the Historical Average?* Discussion Paper No. 2084. Harvard University.

- [50] Cartea, A., & Figueroa, M. (2005). Pricing in Electricity Markets: A Mean Reverting Jump Diffusion Model with Seasonality. *Applied Mathematical Finance*, 12(4), 313-335.
- [51] Cave, M. (2006). Encouraging Infrastructure Competition via the Ladder of Investment. *Telecommunications Policy*, 30(3-4), 223-237.
- [52] Cave, M., & Crandall, R. W. (2001). Telecommunications Policy in North America and Europe. In M. Cave & R. W. Crandall (Eds.), *Telecommunications Liberalization on Two Sides of the Atlantic*. Washington D.C: Brookings Institution Press, Chapter 1.
- [53] Cave, M., & Mason, R. (2001). The Economics and Regulation of the Internet. Working Paper, Brunel University and University of Southampton.
- [54] Cave, M., & Vogelsang, I. (2003). How Access Pricing and Entry Interact. *Telecommunications Policy*, 27(10-11), 717-727.
- [55] Chang, H., Koski, H., & Majumdar, S. K. (2003). Regulation and Investment Behaviour in the Telecommunications Sector: Policies and Patterns in US and Europe. *Telecommunications Policy*, 27(10-11), 677-699.
- [56] Church, J. (2004). *The Impact of Vertical and Conglomerate Mergers on Competition* (Report to Directorate General for Competition, European Commission): Department of Economics, University of Calagary.
- [57] Clewlow, L., & Strickland, C. (1999). Valuing Energy Options in a One Factor Model Fitted to Forward Prices. Working Paper, University of Technology, Sydney and University of Warwick.
- [58] Clewlow, L., & Strickland, C. (2000). *Energy Derivatives – Pricing and Risk Management*. London: Lacima Publications.
- [59] Collis, J., & Hussey, R. (2003). *Business Research* (2nd ed.). New York: Palgrave Macmillan.
- [60] Cooper, J., Luke, F., O'Brien, D., & Vita, M. (2005). A Critique of Professor Church's Report on the Impact of Vertical and Conglomerate Mergers on Competition. *Journal of Competition Law & Economics*, 1(4), 785 -795.
- [61] Cox, D. R. (1967). *Renewal Theory*. London: Chapman and Hall.

- [62] Cox, D. R., & Miller, H. D. (1965). *The Theory of Stochastic Processes*. London: Chapman and Hall.
- [63] Cox, J. C., Ingersoll, J. E., & Ross, S. A. (1985). A Theory of the Term Structure of Interest Rates. *Econometrica*, 53(1), 385-407.
- [64] Cox, J. C., Ross, S. A., & Rubinstein, M. (1979). Option Pricing: A Simplified Approach. *Journal of Financial Economics*, 7(3), 229-263.
- [65] Crandall, R. W., Ingraham, A. T., & Singer, H. J. (2004). Do Unbundling Policies Discourage CLEC. Facilities-Based Investment. Topics in Economic Analysis & Policy, No. 4-1.
- [66] Crandall, R. W., & Sidak, J. G. (2002). Is Structural Separation of Incumbent Local Exchange Carriers Necessary for Competition? *Yale Journal on Regulation*, 19(2), 335-411.
- [67] De Fraja, G. (1999). Regulation and Access Pricing with Asymmetric Information. *European Economic Review*, 43(1), 109-134.
- [68] Deni, M., & Gruber, H. (2005). The Diffusion of Broadband Telecommunications: The Role of Competition. Working Paper, Catholic University, de Louvain
- [69] Di Maggio, P. (1995). Comments on an Article Entitled : What Theory is Not. *Administrative Science Quarterly*, 40(3), 391-397.
- [70] Distaso, W., Lupi, P., & Manenti, F. M. (2006). Platform Competition and Broadband Uptake: Theory and Empirical Evidence. *Information Economics and Policy*, 18(1), 87-106.
- [71] Dixit, A. (1989). Entry and Exit Decisions under Uncertainty. *Journal of Political Economy*, 97(3), 620-638.
- [72] Dixit, A. K., & Pindyck, R. S. (1994). *Investment under Uncertainty*. Princeton, New Jersey: Princeton University Press.
- [73] Doane, M. J., Sibley, D. S., Sidak, J. G., Spulber, D. F., & Williams, M. A. (1996). An Economic Framework for Implementing the Pricing Provisions of the Telecommunications Act of 1996. Unpublished Manuscript.
- [74] Dothan, L. U. (1978). On the Term Structure of Interest Rates. *Journal of Financial Economics*, 6(1), 59-69.

- [75] Duffie, D. (2002). A Short Course on Credit Risk Modelling with Affine Processes. Draft Mimeo, Stanford University.
- [76] Duffie, D., & Singleton, K. (1999). Modelling Term Structures of Defaultable Bonds. *Review of Financial Studies*, 12(1), 687–672.
- [77] Economides, N. (1999). The Telecommunication Act of 1996 and its Impact. *Japan and the World Economy*, 11(4), 455-483.
- [78] Economides, N. (2002). Real Options and the Costs of the Local Telecommunications Network. In J. Alleman & E. Noam (Eds.), *The New Investment Theory of Real Options and its Implication for Telecommunications Economics*. Boston: Kluwer, Chapter 13.
- [79] Economides, N., & White, L. J. (1995). Access and Interconnection Pricing: How Efficient is the Efficient Component Pricing Rule? *The Antitrust Bulletin*, 40(3), 557-579.
- [80] Economides, N., & White, L. J. (1996). The Inefficiency of the ECPR Yet Again: a Reply to Larson. Working Paper, Stern School of Business, New York University.
- [81] Eisner, J., & Lehman, D. E. (2001). *Regulatory Behaviour and Competitive Entry*. Paper presented at the 14th Annual Western Conference, Centre for Research in Regulated Industries.
- [82] El Karoui, N., & Martinelli, L. (2001). Dynamic Asset Pricing Theory with Uncertain Time Horizon. SSRN Working Paper Series, No. 305010.
- [83] El Karoui, N., & Martinelli, L. (2001). A Theoretical Inspection of the Market Price for Default Risk. SSRN Working Paper Series, No. 260566.
- [84] Elliott, R. J., Jeanblanc, M., & Yor, M. (2000). On Models of Default Risk. *Mathematical Finance*, 10(2), 179-195.
- [85] Farrell, J., & Weiser, P. (2003). Modularity, Vertical Integration, and Open Access Policies: Towards a Convergence of Antitrust and Regulation in the Internet Age. *Harvard Journal of Law and Technology*, 17(1), 85-134.
- [86] Faulhaber, G. R. (2002). Broadband Deployment: Is Policy in the Way? In R. W. Crandall & J. H. Alleman (Eds.), *Broadband: Should We Regulate High-Speed Internet Access*. Washington, DC: Brookings Institution Press, 223-244.

- [87] Fay, B. (1996). *Contemporary Philosophy of Social Science: A Multicultural Approach*. Oxford: Blackwell Publications.
- [88] Ford, G. S., & Spiwak, L. J. (2004). The Positive Effects of Unbundling on Broadband Deployment. Phoenix Center Policy Papers, No. 19.
- [89] Galanti, S., & Jung, A. (1997). Low-Discrepancy Sequences: Monte Carlo Simulation of Option Prices. *Journal of Derivatives*, 5(1), 63-83.
- [90] Garcia-Murillo, M., & Gabel, D. (2003). International Broadband Deployment: The Impact of Unbundling. Paper presented at the 31st Telecommunications Policy Research Conference, Arlington, VA.
- [91] George, C. P. R., & Casella, G. (2004). *Monte Carlo Statistical Methods* (2nd ed.). New York: Springer.
- [92] Gibson, R., & Schwartz, E. S. (1990). Stochastic Convenience Yield and the Pricing of Oil Contingent Claims. *Journal of Finance*, 45(3), 959-976.
- [93] Glasserman, P. (2004). *Monte Carlo Methods in Financial Engineering*. New York: Springer.
- [94] Grant, D., Vora, G., & Weeks, D. (1997). Path-Dependent Options: Extending the Monte Carlo Simulation Approach. *Management Science*, 43(11), 1589-1602.
- [95] Greenstein, S., McMaster, S., & Spiller, P. T. (1995). The Effect of Incentive Regulation on Infrastructure Modernization: Local Exchange Companies' Deployment of Digital Technology. *Journal of Economics and Management Strategy*, 4(2), 187-236.
- [96] Harrison, J. M., & Kreps, D. (1979). Martingales and Arbitrage in Multiperiod Securities Markets. *Journal of Economic Theory*, 20, 381-408.
- [97] Harrison, J. M., & Pliska, S. R. (1981). Martingales and Stochastic Integrals in the Theory of Continuous Trading. *Stochastic Processes and Applications*, No 11.
- [98] Harrison, J. M., & Pliska, S. R. (1983). A Stochastic Calculus Model of Continuous Trading: Complete Markets. *Stochastic Processes and Applications*, 15.

- [99] Hausman, J. (1999). The Effect of Sunk Costs in Telecommunications Regulation. In J. Alleman & E. Noam (Eds.), *The New Investment Theory of Real Options and its Implication for Telecommunications Economics*. Norwel, MA: Kluwer, Chapter 12.
- [100] Hausman, J., & Myers, S. (2002). Regulating the United States Railroads: The Effect of Sunk Costs and Asymmetric Risk. *Journal of Regulatory Economics*, 22(3), 287-310.
- [101] Hausman, J., & Sidak, J. G. (1999). A Consumer Welfare Approach to the Mandatory Unbundling of Telecommunication Networks. *The Yale Law Journal*, 109(3), 417-505.
- [102] Hausman, J. A., & Sidak, J. G. (2005). Did Mandatory Unbundling Achieve its Purpose? Empirical Evidence from Five Countries. *Journal of Competition Law & Economics*, 1(1), 173-245.
- [103] Hazlett, T. W. (2002). Regulation and Vertical Integration in Broadband Access Supply. In R. W. Crandall & J. Alleman (Eds.), *Broadband: Should We Regulate High-Speed Internet Access?:* Brookings Institution Press, 197-222.
- [104] Hazlett, T. W. (2005). Rivalrous Telecommunications Networks With and Without Mandatory Sharing. AEI-Brookings Joint Center Working Papers, No. 05-07.
- [105] Hazlett, T. W., & Bazelon, C. (2005). Regulated Unbundling of Telecommunications Networks: A Stepping Stone to Facilities Based Competition. Working Paper, George Mason University.
- [106] Hennisz, W. J., & Zelner, B. A. (2001). The Institutional Environment for Telecommunication Investment. *Journal of Economics & Management Strategy*, 10(1), 123-147.
- [107] Hilliard, J. E., & Reis, J. (1998). Valuation of Commodity Futures and Options under Stochastic Convenience Yields, Interest Rates, and Jump Diffusions in the Spot. *Journal of Financial and Quantitative Analysis*, 33 (1), 61-86.
- [108] Hinz, J., von Grafenstein, L., Verschuere, M., & Wilhelm, M. (2005). Pricing Electricity Risk by Interest Rate Methods. *Quantitative Finance*, 5(1), 49-60.

- [109] Hogendorn, C. (2005). Regulating Vertical Integration in Broadband: Open Access versus Common Carriage. *Journal of Network Economics*, 4(1), 19 – 32.
- [110] Hull, J., & White, A. (1987). The Pricing of Options on Assets with Stochastic Volatilities. *The Journal of Finance*, 42(2), 281-300.
- [111] Hull, J., & White, A. (1988). The Use of the Control Variate Technique in Option Pricing. *Journal of Financial and Quantitative Analysis*, 23(3), 237-251.
- [112] Hull, J., & White, A. (1990). Pricing Interest Rate Derivative Securities. *Review of Financial Studies*, 3(4), 573- 592.
- [113] Ibanez, A. (2004). Valuation by Simulation of Contingent Claims with Multiple Exercise Opportunities. *Mathematical Finance*, 14(2), 223-248.
- [114] Ingersoll, J., & Ross, S. (1992). Waiting to Invest: Investment in Uncertainty. *Journal of Business*, 65(1), 1-29.
- [115] Jamshidian, F. (1989). An Exact Bond Option Formula. *Journal of Finance*, 44(1), 205-209.
- [116] Jarrow, R. A., Lando, D., & Turnbull, S. M. (1997). A Markov Model for the Term Structure of Credit Risk Spreads. *Review of Financial Studies*, 10 481-523.
- [117] Jarrow, R. A., Lando, D., & Yu, F. (2003). Default Risk and Diversification: Theory and Empirical Implications. Working Paper, Cornell University, University of Copenhagen and University of California at Irvine.
- [118] Jarrow, R. A., & Turnbull, S. M. (1995). Pricing Derivatives on Financial Securities Subject to Credit Risk. *Journal of Finance*, 50 (1), 53-85.
- [119] Jarrow, R. A., & Turnbull, S. M. (2000). The Intersection of Market and Credit Risk. *Journal of Banking and Finance*, 24(1-2), 271-299.
- [120] Johnson, P., & Duberly, J. (2000). *Understanding Management Research: An Introduction to Epistemology*. London: Sage Publications.
- [121] Jorde, T. M., Sidak, J. G., & Teece, D. J. (2000). Innovation, Investment and Unbundling. *Yale Journal on Regulation*, 17(1), 1-37.

- [122] Kahn, A. (1988). *The Economics of Regulation: Principles and Institutions*. Cambridge, MA: MIT Press.
- [123] Kant, I. (1965). *Critique of Pure Reason* (N. K. Smith, Trans. Unabridged ed.). New York St. Martin's Press.
- [124] Kasanen, E., & Trigeorgis, L. (1994). A Market Utility Approach to Investment Valuation European. *Journal of Operational Research*, 74(2), 294-309.
- [125] Kaserman, D. L., & Mayo, J. W. (1997). An Efficient Avoided Cost Pricing Rule for Resale of Local Exchange Telephone Services. *Journal of Regulatory Economics*, 11(1), 91-107.
- [126] Keat, R., & Urry, J. (1982). *Social Theory as Science* (2nd ed.). London: Routledge and Kegan Paul.
- [127] Kemna, A. G. Z., & Vorst, A. C. F. (1990). A Pricing Method for Options Based on Average Asset Values. *Journal of Banking and Finance*, 14(1), 113-129.
- [128] Kim, J. H., Bauer, J. M., & Wildman, S. S. (2003). Broadband Uptake in OECD Countries. Paper presented at the 31st Annual Communication, Information and Internet Policy Conference Arlington, VA.
- [129] King, S., & Maddock, R. (2002). Imputation Rules and a Vertical Price Squeeze. *Australian Business Law Review*, 30(1), 43-60.
- [130] Kridel, D., Sappington, D., & Weisman, D. (1996). The Effects of Incentive Regulation in the Telecommunications Industry: A Survey. *Journal of Regulatory Economics*, 9(3), 269-306.
- [131] Kuhn, T. S. (1970). *The Structure of Scientific Revolutions* (2nd ed.). Chicago: University of Chicago Press.
- [132] Kusuoka, S. (1999). A Remark on Default Risk Models. *Advances in Mathematical Economics*, 1, 69-82.
- [133] Laffont, J., & Tirole, J. J. (1994). Access Pricing and Competition. *European Economics Review*, 38(9), 1673–1710.
- [134] Laffont, J. J., & Tirole, J. (2000). *Competition in Telecommunications*. Cambridge, MA: MIT Press.

- [135] Lando, D. (1997). Modelling Bonds and Derivatives with Credit Risk. In M. Dempster & S. Pliska (Eds.), *Mathematics of Derivative Securities*. Cambridge: Cambridge University Press, 369-393.
- [136] Lando, D. (1998). On Cox Processes and Credit Risky Securities. *Review of Derivatives Research*, 2, 99-120.
- [137] Littlechild, S. C. (1983). Regulation of British Telecommunications' Profitability (Report to the Secretary of State). London.
- [138] Lo, A., & Wang, C. (1995). Implementing Option Pricing Models when Assets Prices are Predictable. *Journal of Finance*, 50(1), 87-129.
- [139] Longstaff, F. A., & Schwartz, E. S. (2001). Valuing American Options by Simulation: A Simple Least Squares Approach. *Review of Financial Studies*, 14(1), 113-147.
- [140] Lucia, J. J., & Schwartz, E. S. (2002). Electricity Prices and Power Derivatives: Evidence from the Nordic Power Exchange. *Review of Derivatives Research*, 5(1), 5-50.
- [141] MacDonald, J., Norsworthy, J., & Fu, W. H. (1994). Incentive Regulation in Telecommunications: Why States Don't Choose Price Caps. In M. Crew (Ed.), *Incentive Regulation for Public Utilities*. Boston: Kluwer Academic Publishers, 27-42.
- [142] Madan, D. B., & Unal, H. (1998). Pricing the Risk of Default. *Review of Derivatives Research* 2, 121-160.
- [143] Mason, S. P., & Merton, R. C. (1985). The Role of Contingent Claims Analysis in Corporate Finance. In E. Altman & M. Subrahmanyam (Eds.), *Recent Advances in Corporate Finance*. Homewood: Irwin Professional Publishing, 7-54.
- [144] Mathios, A. D., & Rogers, R. (1989). The Impact of Alternative Forms of State Regulation of AT&T on Direct-Dial, Long-Distance Telephone Rates. *Rand Journal of Economics*, 20(3), 437-453.
- [145] McDonald, R., & Siegel, D. L. (1985). Investment and the Valuation of the Firm When There is an Option to Shut Down. *International Economic Review*, 26 (2), 331-349.

- [146] McDonald, R., & Siegel, D. L. (1986). The Value of Waiting to Invest. *Quarterly Journal of Economics*, 101(4), 707—728.
- [147] Meinshausen, N., & Hambly, B. M. (2004). Monte Carlo Methods for the Valuation of Multiple-Exercise Options. *Mathematical Finance*, 14(4), 557-583.
- [148] Merton, R. C. (1973). Theory of Rational Option Pricing. *Bell Journal of Economics and Management Science*, 4(1), 141-183.
- [149] Merton, R. C. (1997). On the Pricing of Contingent Claims and the Modigliani-Miller Theorem. *Journal of Financial Economics*, 5(2), 241-249.
- [150] Mitchell, J. C. (1983). Case and Situation Analysis. *The Sociological Review*, 31(3), 186-211.
- [151] Musiela, M., & Rutkowski, M. (2005). *Martingale Methods in Financial Modeling*. (2nd ed.). New York: Springer.
- [152] NERA. (1999). Estimating the Long Run Incremental Cost of PSTN Access (Report for the Australian Competition & Consumer Commission). London.
- [153] Ofcom. (1997). Network Charge Controls from 1997 (Consultation Document). London.
- [154] Ofcom. (2004a). Direction Setting the Margin between IPStream and ATM interconnection Prices (Consultation Document). London.
- [155] Ofcom. (2004b). Review of Wholesale Broadband Markets Access Markets (Consultation Document). London.
- [156] Ofcom. (2005a). Local Loop Unbundling: Setting the Fully Unbundled Rental Charge Ceiling and Minor Amendment to SMP Conditions FA6 and FB6 (Consultation Document). London.
- [157] Ofcom. (2005b). Review of BT's Network Charge Controls (Explanatory Statement). London: .
- [158] Ofcom. (2005c). Valuing Copper Access (Consultation Document). London.

- [159] Ofcom. (2005d). Wholesale Line Rental: Reviewing and Setting Charge Ceilings for WLR Services (A Consultation Document). London.
- [160] Ofcom. (2006). Review of Wholesale Broadband Markets 2006/7 (Consultation Document). London.
- [161] Ofcom. (2007). The UK Communications Market (Market Report). London.
- [162] Oftel. (2002). Direction to Resolve a Dispute between BT, Energis and Thus Concerning Xdsl Interconnection at the ATM Switch (Report Issued by the Director General of Telecommunications). London.
- [163] Paddock, J. L., Siegel, D. L., & Smith, J. L. (1988). Option Valuation of Claims on Real Assets: The Case of Offshore Petroleum Leases. *Quarterly Journal of Economics*, 103(3), 479-508.
- [164] Pham-Gia, T., & Turkkan, N. (1999). Availability for a Gamma Alternating Renewal Process. *Naval Research Logistics*, 46(7), 822-844.
- [165] Pindyck, R. (1998). Irreversible Investment, Capacity Choice, and the Value of the Firm. *American Economic Review*, 78(5), 969-985.
- [166] Pindyck, R. S. (2007). Mandatory Unbundling and Irreversible Investment in Telecom Networks. *Review of Network Economics*, 6(3), 274-298.
- [167] Pindyck, R. S. (2005). Pricing Capital under Mandatory Unbundling and Facilities Sharing. NBER Working Paper Series, No. 11225.
- [168] Pindyck, R. S. (2005). Sunk Capital and Real Options in Antitrust. NBER Working Papers, No. W11430
- [169] Popper, K. (1963). *Conjectures and Refutations : the Growth of Scientific Knowledge*. Routledge & Kegan Paul.
- [170] Posner, R. (1976). *Antitrust Law: An Economic Perspective*. Chicago: University of Chicago Press.
- [171] Riordan, M. H., & Salop, S. C. (1994). Evaluating Vertical Mergers: A Post-Chicago Approach. *Antitrust Law Journal*, 63 (1), 513- 568.
- [172] Rood, H., & te Velde, R. A. (2003). Investment Strategies in the Netherlands. *Telecommunications Policy*, 27(10-11), 701–715.

- [173] Rorty, R. (1972-80). *Consequence of Pragmatism: Essays*. Minneapolis: University of Minnesota Press.
- [174] Rubinfeld, D. L., & Singer, H. J. (2001). Vertical Foreclosure in Broadband Access. *Journal of Industrial Economics*, 49 (3), 299-318.
- [175] Rutkowski, M. (1999). On Models of Default Risk. Working Paper, Warsaw University of Technology.
- [176] Ryan, B., Scapens, R. W., & Theobald, M. (1992). *Research Methods and Methodology in Finance and Accounting*. London: Academic Press Limited.
- [177] Salinger, M. (1998). Regulating Prices to Equal Forward-Looking Costs. *Journal of Regulatory Economics*, 14(2), 149-163.
- [178] Sappington, E. M., & Weisman, D. L. (1996). *Designing Incentive Regulation for Telecommunications Industry*. Cambridge, MA: MIT Press.
- [179] Schmalensee, R., & Rohlfs, J. (1992). Productivity Gains Resulting From Interstate Price Caps For AT&T. Working Paper, National Economic Research Associates.
- [180] Schwartz, E. S. (1997). The Stochastic Behavior of Commodity Prices: Implications for Valuation and Hedging. *Journal of Finance*, 52(3), 923–973.
- [181] Schwartz, E. S., & Moon, M. (2000). Evaluating Research and Development Investments. In M. J. Brennan & L. Trigeorgis (Eds.), *Project Flexibility, Agency, and Competition: New Developments in the Theory and Application of Real Options*. New York: Oxford University Press, Chapter 6.
- [182] Shin, R., & Ying, J. (1993). *Efficiency in Regulatory Regimes: Evidence From Price Caps*. Paper presented at the 21st Annual Telecommunications Policy Research Conference, Solomons, Maryland.
- [183] Sibley, D. S., & Weisman, D. L. (1998). The Competitive Incentives of Vertically Integrated Local Exchange Carriers: An Economic and Policy Analysis. *Journal of Policy Analysis and Management*, 17(1), 74-93.

- [184] Sibley, D. S., & Weisman, D. L. (1998). Raising Rivals' Costs: The Entry of an Upstream Monopolist into Downstream Markets. *Information Economics and Policy*, 10(4), 451-470.
- [185] Sidak, G., & Spulber, D. (1997). *Deregulatory Takings and the Regulatory Contract*. Cambridge: Cambridge University Press.
- [186] Smith, M. J. (1998). *Social Science in Question*. London: Sage Publications.
- [187] Starkey, K., & Madan, P. (2001). Bridging the Relevance Gap: Aligning the Stakeholder in the Future of Management Research. *British Journal of Management*, 12(Supplement), S3-S26.
- [188] Syski, R. (1989). *Random Processes*. New York Marcel Dekker, Inc.
- [189] Tardiff, T., & Taylor, W. (1993). Telephone Company Performance Under Alternative Forms of Regulation in the U.S. Working Paper, National Economic Research Associates.
- [190] Tardiff, T., Taylor, W., & Zarkadas, C. (1994). Periodic Review of Price Cap Plans. Working Paper, National Economic Research Associates.
- [191] Taylor, H. M., & Karlin, S. (1998). *An Introduction to Stochastic Modeling*. (3rd ed.). London Academic Press.
- [192] Thomas, A. B. (2004). *Research Skills for Management Studies*. London: Routledge.
- [193] Tourinho, O. (1979). The Option Value of Reserves of Natural Resources. Working Paper, University of California, Berkeley.
- [194] Trigeorgis, L. (1993). The Nature of Option Interactions and the Valuation of Investments with Multiple Real Options. *Journal of Financial and Quantitative Analysis*, 26(1), 1-20.
- [195] Trigeorgis, L. (1996). *Real Options: Managerial Flexibility and Strategy In Resource Allocation*. Cambridge, MA: MIT Press.
- [196] Vahvilainen, I. (2002). Basics of Electricity Derivatives Pricing in Competitive Markets. *Applied Mathematical Finance*, 9(1), 45-60.
- [197] Valletti, T. (2003). The Theory of Access Pricing and its Linkage with Investment Incentives. *Telecommunications Policy*, 27(10-11), 659-675.

- [198] Vasicek, O. A. (1977). An Equilibrium Characterization of the Term Structure. *Journal of Financial Economics*, 5(2), 77-188.
- [199] Vickers, J. (1995). Competition and Regulation in Vertically Related Markets. *Review of Economic Studies*, 62(210), 1-17.
- [200] Vogelsang, I. (2003). Price Regulation of Access to Telecommunication Networks. *Journal of Economic Literature*, 43(3), 830-862.
- [201] Wallsten, S. (2006). Broadband and Unbundling Regulations in OECD Countries. AEI-Brookings Joint Center Working Papers, No. 06-16.
- [202] Wallsten, S. (2006). Broadband Penetration: An Empirical Analysis of State and Federal Policies. AEI-Brookings Joint Center Working Papers, No. 05-12.
- [203] Waverman, L., & Dasgupta, K. (2006). Investment in Telecommunication Networks: A 21st Century Perspective. Working Paper, London Business School, University of London.
- [204] Weisman, D. (1998). The Incentive to Discriminate by a Vertically-Integrated Regulated Firm: A Reply. *Journal of Regulatory Economics*, 14(1), 87-91.
- [205] Whish, R. (2003). *Competition Law* (Fifth ed.). London: LexisNexis.
- [206] WIK-Consult, G. (2005). Analytical Cost Model Broadband Network (Report to Regulatory Authority for Telecommunications and Posts). Bad Honnef.
- [207] WIK-Consult, G. (2005). An Analytical Cost Model for the National Core Network (Report to Regulatory Authority for Telecommunications and Posts). Bad Honnef.
- [208] Williams, A. (1996). An Economic Framework for Implementing the Pricing Provisions of the Telecommunications Act of 1996. Unpublished Manuscript.
- [209] Willig, R. D. (1979). The Theory of Network Access Pricing. In H. Trebig (Ed.), *Issues in Public Utility Regulation*: Michigan State University, 109-152.

- [210] Wright, S., Mason, R., & Miles, D. (2003). *A Study into Certain Aspects of the Cost of Capital of Regulated Utilities in the UK* (Report to UK Economic Regulators and Office of Fair Trading). London.
- [211] Yin, R. K. (2003). *Case Study Research: Design and Methods* (3rd ed.). California: Sage Publications.
- [212] Yoshimoto, A., & Kato, T. (2004). Effects of Estimation Length on Parameter Estimates of Brownian Motion for Log Price Dynamics. *Journal of Forest Research*, 9(3), 239-248.